



UNIT HEATER



Contents

Nomenclature	4
Introduction	5
Selection Examples	5
Technical and Performance Data	7
Selection Considerations	9
Dimensions	11
Piping Recommendations	12
Air Distribution pattern	13



NOMENCLATURE

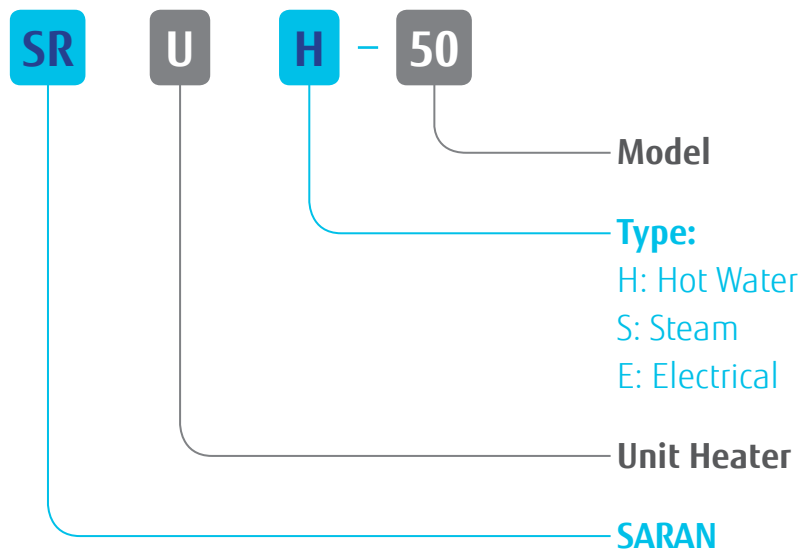

Introduction

Saran unit heaters offered in ten models in three type such as hot water, steam and electrical. These units cover a wide range of heating capacities and suitable for use in commercial and industrial applications.

All units are constructed from heavy gauge galvanized steel sheet covered with fine quality paint. Water and steam coils are manufactured from seamless copper tubes mechanically bonded to high efficiency wavy corrugated aluminum fins (In steam pressures above 40 psig, steam coils are made of seamless steel tubes with spiral aluminum fins).

Saran unit heaters equipped with direct driven axial fans which statically and dynamically balanced. Single phase motors (220V/50Hz) at 900 RPM or 1400 RPM used in unit heaters as standard but three phase (380V/50Hz) motors at 1400 RPM are available upon request. In addition, all units equipped with individually adjustable horizontal louvers for simple vertical air distribution adjustment.

Main Features:

- Heavy gauge galvanized casing
- High efficiency direct driven axial fans for quiet operation
- Space saving & light weight
- Low power consumption
- High efficiency coil
- Adjustable louvers
- Three type capacities for electrical heater models (Low, Medium and High)
- Complete safety controllers for electrical heaters (Air flow switch, Circuit breaker and High temperature thermostat)
- Quick electrical connections

Selection Examples

Selection Example 1:

Given:

Total Heating Load: 125,000 Btu/hr

Ambient Altitude: 4000 ft

Entering Air DB Temperature: 50°F

Entering Water Temperature: 160°F

Leaving Water Temperature: 140°F

Step1: Appropriate Fan Coil Unit Selection

By referring to table 1, we can see heating capacity of SRUH-300 with 900 RPM motor is 155000 Btu/hr in the standard conditions (entering air temperature of 60°F and entering/leaving hot water temperature of 180°F / 160°F in sea level). Therefore, in first step, we select this unit and then we calculate actual capacity of unit in our conditions.

Step2: Correction Factors Consideration

Because of unit heaters performance tables are based on standard conditions, we should be use load adjustment factor in our conditions, so by referring to table 4, we can see hot water correction factor in our conditions (E.A.T = 50°F and E.W.T = 160°F) is 0.89 and by referring to table 7, altitude correction factor is 0.936. Therefore, we have:

$$\text{Actual Heating Capacity} = 155000 \times 0.89 \times 0.936 = 129121 \text{ Btu/hr}$$

Therefore, the chosen unit satisfies the load requirements.

In addition, by referring to table 6, we can see air flow rate correction factor in entering air temperature of 50°F is 1.02, so by multiply nominal air flow rate of SRUH-300 in table 1 to this value, we have:

$$\text{Actual Air Flow Rate (CFM)} = 2700 \times 1.02 = 2754 \text{ CFM}$$

Step3: Determine Water Pressure Drop

To determine water pressure drop, we need to calculate water flow rate in our conditions and actual flow rate ratio by using following formulas:

$$\text{Hot water flow rate (GPM)} = \frac{\text{Actual Heating Capacity (Btu/hr)}}{500 \times \text{Hot Water Flow Range (°F)}} = \frac{129121}{500 \times 20} = 12.9 \text{ GPM}$$

$$\text{Hot water flow ratio} = \frac{\text{Actual Water Flow Rate}}{\text{Nominal Flow Rate}} = \frac{12.9}{15.5} = 0.83$$

Therefore, by referring to table 5, we can see water pressure correction factor in calculated water flow ratio is 0.73, so we have:

$$\text{Water Pressure Drop (FT.WG)} = \text{Nominal P.D (FT.WG)} \times \text{Correction Factor (table 5)} = 2 \times 0.73 = 1.46 \text{ FT.WG}$$



Selection Examples (Cont.)

Selection Example 2:

Given:

Total Heating Load: 265,000 Btu/hr

Ambient Altitude: Sea Level

Entering Air DB Temperature: 50°F

Saturated Steam Pressure: 30 psig

Step1: Appropriate Fan Coil Unit Selection

By referring to table 2, we can see heating capacity of SRUS-400 with 900 RPM motor is 259000 Btu/hr in the standard conditions (entering air temperature of 60°F and saturated steam pressure of 30 psig in sea level). Therefore, in first step, we select this unit and then we calculate actual capacity of unit in our conditions.

Step2: Correction Factors Consideration

Because of unit heaters performance tables are based on standard conditions, we should be use load adjustment factor in our conditions, so by referring to tables 8, we can see correction factor in our conditions (E.A.T = 50°F and Steam Pressure = 30 psig) is 1.045 and by referring to table 7, altitude correction factor is 1. Therefore, we have:

$$\text{Actual Heating Capacity} = 259000 \times 1.045 \times 1 = 270655 \text{ Btu/hr}$$

Therefore, the chosen unit satisfies the load requirements.

In addition, by referring to table 6, we can see air flow rate correction factor in entering air temperature of 50°F DB is 1.02, so by multiply nominal air flow rate of SRUS-400 in table 2 to this value, we have:

$$\text{Actual Air Flow Rate (CFM)} = 3700 \times 1.02 = 3774 \text{ CFM}$$

Step3: Determine Condensate Mass Flow Rate

To determine condensate mass flow rate, we can using following formula:

$$\text{Condensate Mass Flow Rate (lb/hr)} = \frac{\text{Actual Heating Capacity (Btu/hr)}}{970} = \frac{270655}{970} = 288.16 \text{ lb/hr}$$

Table 1: Hot Water Unit Heater

Model	Motor		Air Flow (CFM)	Capacity (MBH)	Water Flow (GPM)	Leaving Air Temp. (°F)	Water P.D (FT.WG)	Weight (kg)
	Nominal RPM	Power (W)						
SRUH-25	900	90	280	15	1.5	109.6	0.25	38
SRUH-50	900	90	480	25	2.5	108.2	0.45	44
SRUH-75	900	90	700	36	3.6	107.6	0.50	47
	1400	135	850	41	4.1	104.8	0.55	47
SRUH-100	900	100	900	50	5	111.4	0.60	53
	1400	160	1100	57	5.7	107.9	0.70	53
SRUH-125	900	100	1000	55	5.5	110.9	0.75	61
	1400	160	1300	65	6.5	106.3	0.80	61
SRUH-150	900	110	1300	70	7.0	109.8	1.05	65
	1400	160	1600	80	8.0	106.3	1.10	65
SRUH-200	900	175	1700	97	9.7	112.8	1.60	78
	1400	175	1800	100	10	113.4	1.70	76
SRUH-250	900	230	2000	114	11.4	112.7	2.00	87
	1400	210	2200	120	12.0	110.5	2.30	84
SRUH-300	900	230	2700	155	15.5	113.2	2.00	103
	1400	370	3000	165	16.5	110.9	2.60	102
SRUH-400	900	480	3700	203	20.3	110.8	3.60	130
	1400	380	4000	213	21.3	109.3	3.80	125

Table 2: Saturated Steam Unit Heater

Model	Motor		Air Flow (CFM)	Capacity (MBH)	Water Flow (GPM)	Leaving Air Temp. (°F)	Water P.D (FT.WG)	Weight (kg)
	Nominal RPM	Power (W)						
SRUS-25	900	90	280	28.1	30.3	153.0	38	38
SRUS-50	900	90	480	43.7	47.1	144.4	44	44
SRUS-75	900	90	700	63.3	68.2	143.7	47	47
	1400	135	850	71.2	76.7	137.5	47	47
SRUS-100	900	100	900	77.6	83.6	139.9	53	53
	1400	160	1100	87.3	94.1	133.5	53	53
SRUS-125	900	100	1000	85.9	92.5	139.5	61	61
	1400	160	1300	100.0	107.7	131.2	61	61
SRUS-150	900	110	1300	105.1	113.2	134.9	65	65
	1400	160	1600	118.1	127.2	128.3	65	65
SRUS-200	900	175	1700	138.0	148.6	135.1	78	78
	1400	175	1800	142.6	153.6	133.4	76	76
SRUS-250	900	230	2000	157.1	169.2	132.7	87	87
	1400	210	2200	165.7	178.4	129.7	84	84
SRUS-300	900	230	2700	206.0	221.9	130.6	103	103
	1400	370	3000	218.3	235.1	127.4	102	102
SRUS-400	900	480	3700	259.0	278.9	124.8	130	130
	1400	380	4000	270.0	290.7	122.5	125	125

NOTE

- MBH = 1000 Btu/hr
- Capacities are based on entering air temperature of 60°F and entering/leaving hot water temperature of 180°F / 160°F (saturated steam pressure of 30 psig) in sea level.
- Motor data are based on 220V/1ϕ/50HZ (380V/3ϕ/50HZ in 1400 RPM is available upon request).

Table 3a: Electrical Unit Heater (900 RPM)

Model	Type	Air Flow (CFM)	Capacity (MBH)	ΔT (°F)	Electrical Data			Weight (kg)
					Motor Power (W)	Motor Current (Amp.)	Max. Current (Amp.)	
SRUE-75	L	1000	15.4	14	90	0.4	7.3	40
	M		23.0	21		0.4	10.7	45
	H		30.7	28		0.4	14.1	48
SRUE-100	L	1200	15.4	12	100	0.5	7.3	53
	M		30.7	24		0.5	14.2	58
	H		38.4	30		0.5	17.6	63
SRUE-200	L	1500	15.4	9	110	0.5	7.4	75
	M		30.7	19		0.5	14.2	82
	H		46.1	28		0.5	21.1	88
SRUE-250	L	1850	20.5	10	175	0.8	9.9	90
	M		40.9	20		0.8	19.1	93
	H		61.4	31		0.8	28.2	97
SRUE-300	L	2900	46.1	15	230	1.1	21.6	105
	M		61.4	20		1.1	28.4	109
	H		92.1	29		1.1	42.1	115
SRUE-400	L	4800	46.1	9	480	2.5	23.0	123
	M		107.5	21		2.5	50.4	128
	H		153.5	30		2.5	70.9	130

Table 3b: Electrical Unit Heater (1400RPM)

Model	Type	Air Flow (CFM)	Capacity (MBH)	ΔT (°F)	Electrical Data			Weight (kg)
					Motor Power (W)	Motor Current (Amp.)	Max. Current (Amp.)	
SRUE-75	L	1400	15.4	10	180	0.4	7.3	40
	M		30.7	20		0.4	14.1	45
	H		46.1	30		0.4	21.0	48
SRUE-100	L	1600	23.0	13	200	0.5	10.8	53
	M		38.4	22		0.5	17.6	58
	H		53.7	31		0.5	24.5	63
SRUE-200	L	2200	30.7	13	215	0.5	14.2	75
	M		46.1	19		0.5	21.0	82
	H		76.8	32		0.5	34.7	88
SRUE-250	L	2500	30.7	11	250	0.5	14.2	90
	M		61.4	23		0.5	27.9	93
	H		81.9	30		0.5	37.0	97
SRUE-300	L	3500	46.1	12	370	0.8	21.3	105
	M		76.8	20		0.8	35.0	109
	H		122.8	32		0.8	55.5	115
SRUE-400	L	4300	46.1	10	414	0.9	21.4	123
	M		92.1	20		0.9	41.9	128
	H		153.5	33		0.9	69.3	132

NOTE

- MBH = 1000 Btu/hr
- ΔT = Air Temperature Rise
- System Power Supply= 380~400V/3φ /50HZ.
- The above data is subject to change without prior notice.



Selection Considerations

Saran unit heaters rating data presented in the table 1 and 2, indicate capacity of them at standard condition, so for other condition, following performance adjustment factors shall be attend in unit heaters selection

Table 4: Hot Water Correction Factor

Entering Air Temp. (°F)	Entering Water Temperature (°F)										
	150	160	170	180	190	200	210	220	230	240	250
30	1.035	1.115	1.210	1.295	1.380	1.465	1.545	1.640	1.720	1.810	1.895
40	0.940	1.025	1.105	1.195	1.275	1.360	1.440	1.535	1.620	1.700	1.785
50	0.840	0.890	1.050	1.090	1.175	1.265	1.345	1.430	1.510	1.600	1.690
60	0.743	0.835	0.920	1.000	1.080	1.165	1.240	1.325	1.405	1.500	1.580
70	0.650	0.745	0.825	0.905	0.980	1.070	1.150	1.235	1.315	1.395	1.480
80	0.570	0.650	0.735	0.815	0.895	0.980	1.060	1.140	1.220	1.300	1.380
90	0.475	0.560	0.640	0.720	0.805	0.885	0.965	1.050	1.130	1.210	1.280
100	0.395	0.475	0.560	0.710	0.790	0.870	0.955	1.035	1.115	1.165	1.185

NOTE

- To determine unit ratings at various entering water and air temperature, multiply given values from table1 by the appropriate factor from the above table.

Table 5: Water Pressure Drop Correction Factor

Water Flow Ratio	0.5	0.6	0.7	0.8	0.9	1.0	1.1	1.2	1.3	1.4	1.5	1.6	1.7	1.8
Correction Factor	0.3	0.4	0.5	0.7	0.8	1.0	1.2	1.4	1.6	1.8	2.1	2.3	2.6	2.8

NOTE

- Adjust pressure drop in table 1 by multiplying appropriate factors from the above table.

Table 6: Air Flow Rate Correction Factor

Entering Air Temp. (°F)	10	20	30	40	50	60	70	80	90	100
Correction Factor	1.11	1.08	1.06	1.04	1.02	1.00	0.98	0.96	0.95	0.93

NOTE

- Adjust air flow rate in table 1 by multiplying appropriate factors from the above table.

Table 7: Altitude Correction Factor

Altitude (ft)	0	1000	2000	3000	4000	5000	6000
Correction Factor	1.000	0.984	0.968	0.952	0.936	0.920	0.904

NOTE

Selection Considerations (Cont.)

Table 8: Saturated Steam Correction Factor

Ent. Air Temp. (°F)	Steam Pressure (Lbs/In ²)															
	0	2	5	10	15	20	30	40	50	60	80	100	125	150	175	200
-30	1.133	1.163	1.2	1.258	1.308	1.348	1.42	1.482	1.532	1.585	1.654	1.717	1.792	1.847	1.903	1.956
-20	1.082	1.113	1.153	1.211	1.258	1.301	1.373	1.431	1.483	1.528	1.605	1.67	1.74	1.801	1.855	1.903
-10	1.036	1.066	1.107	1.164	1.212	1.254	1.325	1.384	1.436	1.481	1.558	1.623	1.693	1.755	1.808	1.856
0	0.989	1.02	1.06	1.117	1.166	1.207	1.278	1.338	1.389	1.434	1.512	1.576	1.647	1.708	1.762	1.81
10	0.942	0.973	1.013	1.071	1.118	1.161	1.233	1.292	1.342	1.388	1.465	1.53	1.601	1.66	1.715	1.764
20	0.896	0.926	0.967	1.024	1.073	1.114	1.186	1.244	1.296	1.341	1.418	1.483	1.553	1.615	1.669	1.717
30	0.849	0.88	0.92	0.977	1.026	1.067	1.139	1.198	1.25	1.294	1.372	1.436	1.506	1.568	1.622	1.67
40	0.802	0.833	0.873	0.93	0.978	1.021	1.092	1.151	1.202	1.248	1.325	1.39	1.461	1.521	1.575	1.628
45	0.779	0.81	0.85	0.907	0.955	0.997	1.059	1.128	1.18	1.224	1.302	1.366	1.436	1.496	1.552	1.601
50	0.756	0.796	0.827	0.984	0.932	0.974	1.045	1.104	1.156	1.201	1.273	1.343	1.414	1.474	1.529	1.576
55	0.732	0.763	0.803	0.861	0.908	0.951	1.023	1.081	1.133	1.178	1.255	1.32	1.39	1.451	1.505	1.553
60	0.709	0.74	0.78	0.837	0.885	0.927	1	1.058	1.109	1.154	1.231	1.297	1.367	1.427	1.482	1.531
65	0.686	0.716	0.757	0.814	0.862	0.904	0.976	1.034	1.086	1.131	1.209	1.273	1.343	1.407	1.459	1.506
70	0.662	0.693	0.733	0.791	0.838	0.881	0.935	1.011	1.063	1.108	1.186	1.25	1.32	1.38	1.435	1.484
75	0.639	0.67	0.71	0.767	0.815	0.859	0.93	0.988	1.04	1.084	1.163	1.226	1.297	1.357	1.412	1.46
80	0.616	0.646	0.687	0.744	0.792	0.834	0.906	0.965	1.016	1.061	1.139	1.203	1.273	1.335	1.389	1.436
85	0.592	0.623	0.663	0.72	0.768	0.811	0.883	0.941	0.993	1.038	1.116	1.18	1.251	1.31	1.365	1.414
90	0.569	0.6	0.64	0.696	0.745	0.787	0.86	0.918	0.969	1.014	1.093	1.156	1.226	1.288	1.342	1.39
100	0.522	0.553	0.593	0.65	0.698	0.732	0.813	0.871	0.923	0.968	1.045	1.11	1.181	1.24	1.295	1.344
110	0.476	0.506	0.547	0.603	0.652	0.694	0.766	0.825	0.876	0.921	0.998	1.063	1.134	1.194	1.248	1.297
120	0.429	0.46	0.5	0.556	0.605	0.647	0.72	0.778	0.83	0.874	0.952	1.027	1.086	1.147	1.201	1.251
140	0.336	0.366	0.407	0.464	0.512	0.554	0.626	0.685	0.737	0.781	0.858	0.923	0.993	1.055	1.108	1.158
160	0.242	0.273	0.313	0.37	0.418	0.46	0.533	0.591	0.642	0.688	0.765	0.831	0.901	0.961	0.012	1.065
180	0.149	0.179	0.22	0.277	0.325	0.367	0.439	0.498	0.55	0.594	0.671	0.737	0.808	0.868	0.921	0.97
200	0.056	0.085	0.127	0.183	0.232	0.274	0.345	0.405	0.455	0.501	0.577	0.643	0.713	0.775	0.829	0.876

NOTE

- To determine unit ratings at various entering air temperature and saturated steam pressure, multiply given values from table 2 by the appropriate factor from the above table.

Table 9: Properties of Saturated Steam

Pressure (psig)	0	2	3	5	8	10	15	20	25	30	35	40	45	50	60
Temperature (°F)	212.00	218.47	221.50	227.16	234.78	239.41	249.73	258.79	266.85	174.08	280.64	286.74	292.37	297.70	307.30
Latent Heat (Btu/Lb)	970.40	966.20	964.27	960.54	955.58	952.45	945.49	939.26	933.63	928.50	923.77	919.27	915.15	911.24	903.91

Pressure (psig)	70	75	80	90	100	110	120	125	130	140	150	175	200	225	250
Temperature (°F)	316.03	320.00	323.89	331.16	337.86	344.22	350.09	353.00	355.65	360.89	365.92	377.47	387.88	397.27	406.01
Latent Heat (Btu/Lb)	897.28	894.20	891.08	885.42	880.82	874.85	870.05	867.70	865.48	861.12	856.92	847.02	838.00	828.30	820.00

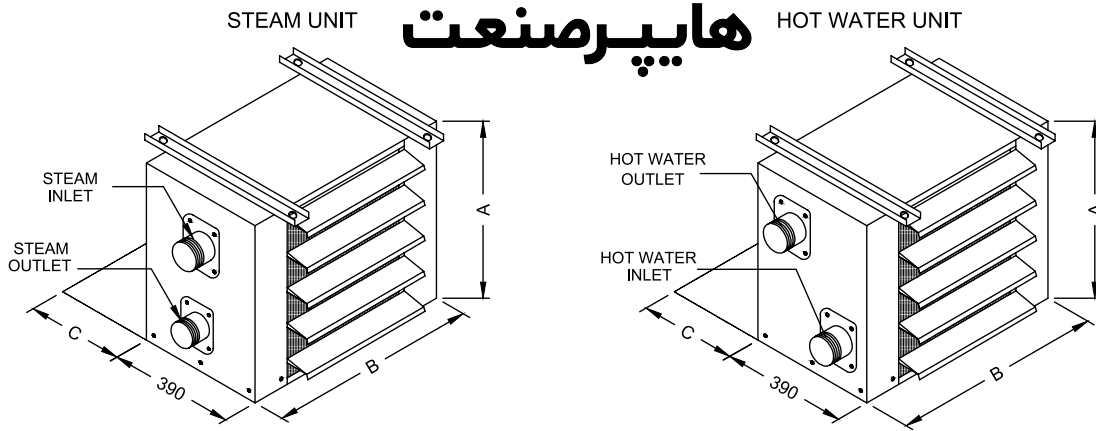

Table 10

Model	A		B	C	Hot Water Connections	Steam Connections	
	900 RPM	1400 RPM				Outlet	Inlet
SRUH-25, SRUS-25	400	-	510	300	2×1"	1 1/4"	1"
SRUH-50, SRUS-50	435	-	550	300	2×1"	1 1/4"	1"
SRUH-75, SRUS-75	510	510	600	350	2×1"	1 1/2"	1 1/4"
SRUH-100, SRUS-100	510	510	650	350	2×1"	2"	1 1/4"
SRUH-125, SRUS-125	550	550	650	350	2×1"	2"	1 1/4"
SRUH-150, SRUS-150	550	550	730	350	2×1"	2"	1 1/4"
SRUH-200, SRUS-200	585	585	830	400	2×1 1/4"	2"	1 1/4"
SRUH-250, SRUS-250	700	585	880	400	2×1 1/4"	2"	1 1/4"
SRUH-300, SRUS-300	700	700	930	400	2×1 1/4"	2"	1 1/4"
SRUH-400, SRUS-400	800	700	1020	400	2×1 1/4"	2"	1 1/4"

NOTE

- All dimensions are in mm
- The above data is subject to change without prior notice.

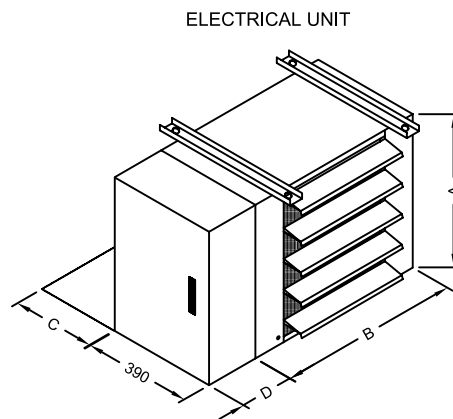
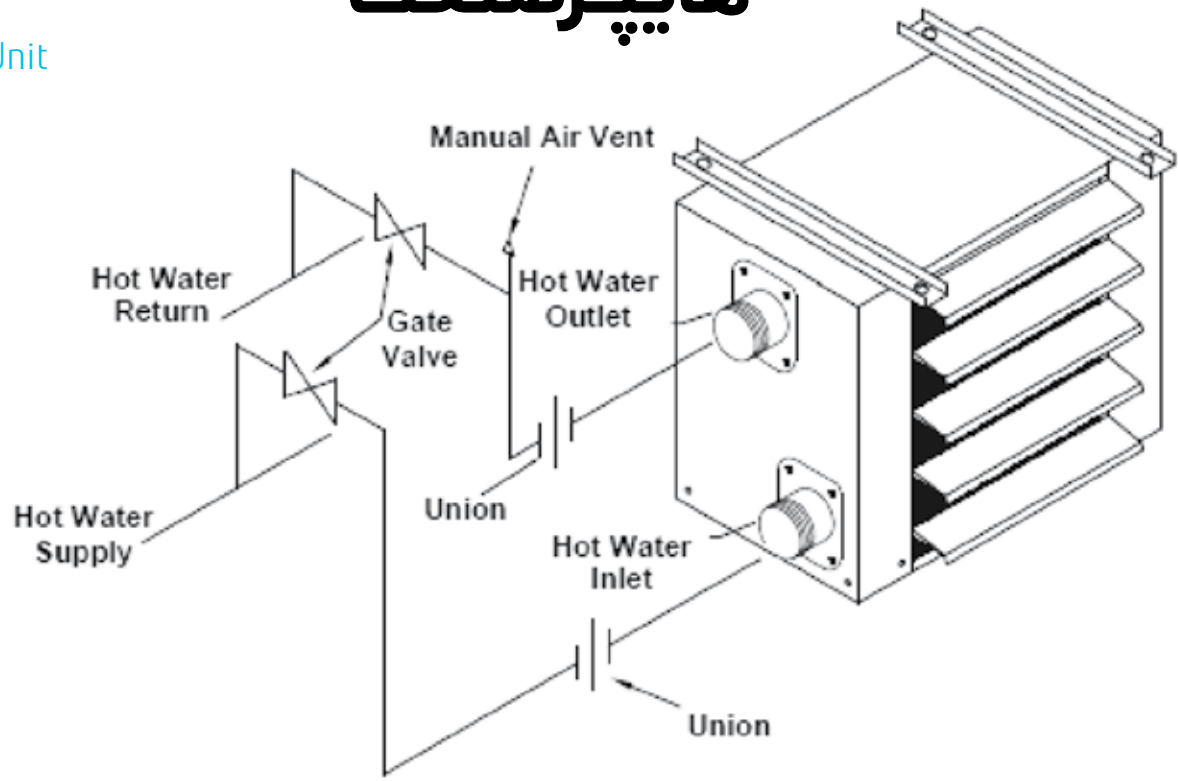

Table 11

Model	A		B	C	D
	900 RPM	1400 RPM			
SRUE-75	510	510	600	350	170
SRUE-100	510	510	650	350	170
SRUE-200	585	585	830	400	170
SRUE-250	585	585	880	400	170
SRUE-300	700	700	930	400	170
SRUE-400	800	700	1020	400	170

Hot Water Unit



Steam Unit

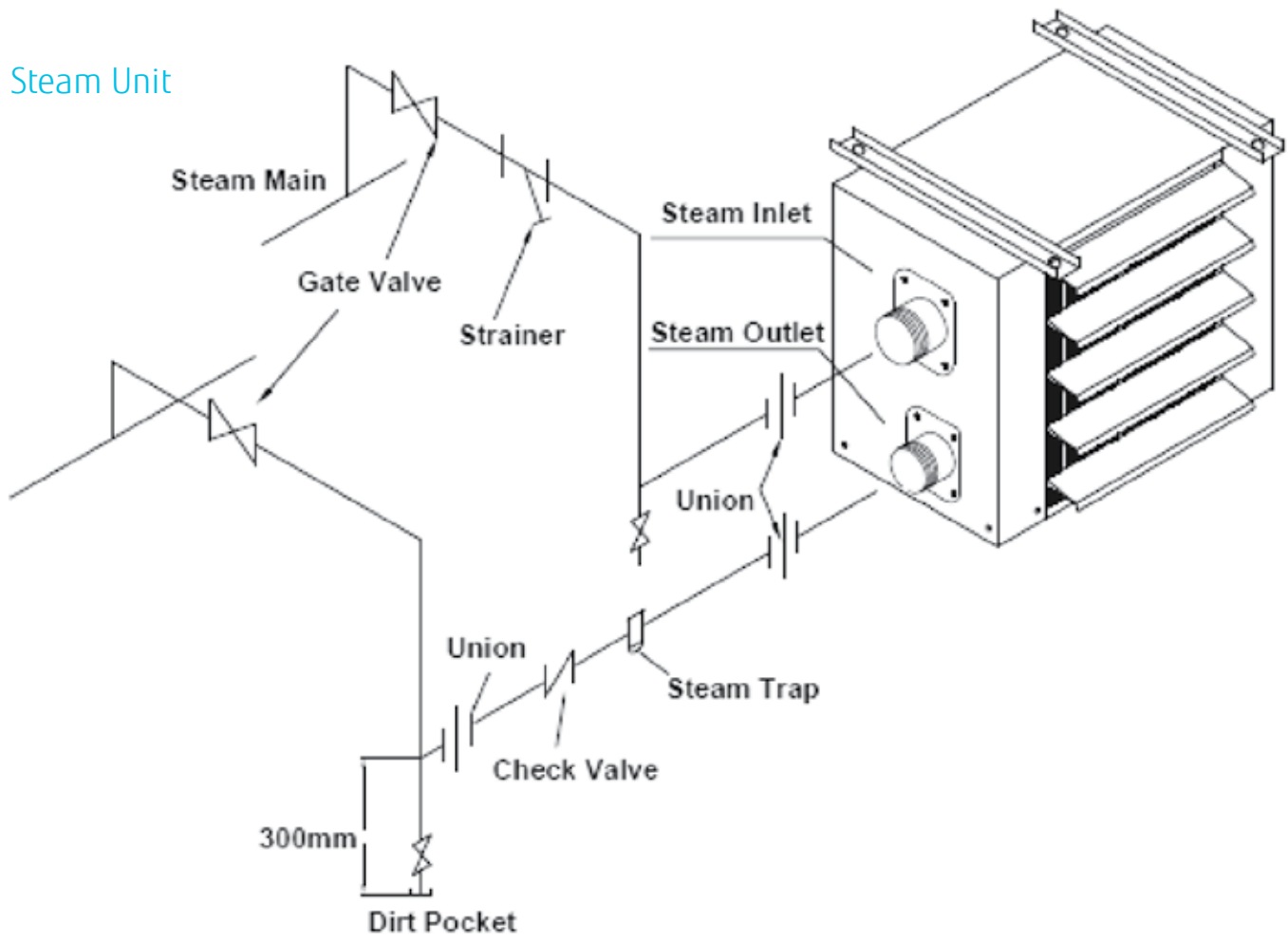

Air Distribution Pattern

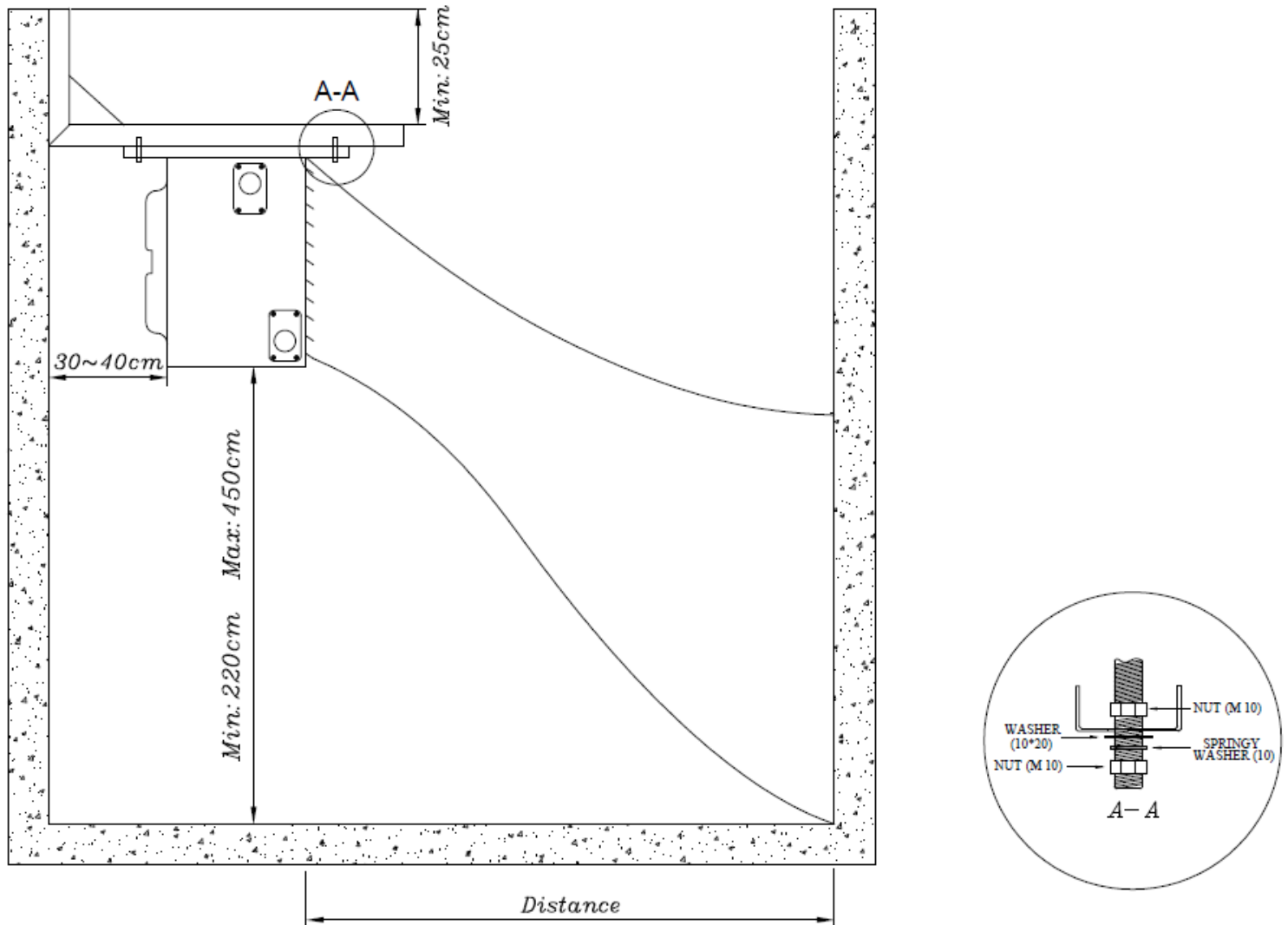

Table 12: Horizontal Actual Discharge Distance

Model	Distance (m)	
	Hot Water & Steam Unit Heater	Electrical Unit Heater
25	2.5	-
50	2.5	-
75	5.0	6.0
100	5.0	6.5
125	6.0	-
150	6.0	-
200	6.0	6.5
250	6.5	6.5
300	7.0	7.0
400	7.5	8.0

NOTE

- Above values are based on 180°F entering water temperature (40 psig saturated steam or H type electrical heater), 60°F entering air temperature, 1400 RPM motor and 45° blades angle.