

## 9 Series

Final level of protection in electrical distribution

# Multi9

Catalogue 2021

Multistandard protection for OEM applications





# Green Premium™

An industry leading portfolio of offers delivering sustainable value



More than 75% of our product sales offer superior transparency on the material content, regulatory information and environmental impact of our products:

- RoHS compliance
- REACH substance information
- Industry leading # of PEP's\*
- Circularity instructions



Discover what we mean by green

www.famcocorp.com

E-mail: info@famcocorp.com

@famco\_group

The Green Premium program stands for our commitment to deliver customer valued sustainable performance. It has been upgraded with recognized environmental claims and extended to cover all offers including Products, Services and Solutions.

#### CO<sub>2</sub> and P&L impact through... Resource Performance

Green Premium brings improved resource efficiency throughout an asset's lifecycle. This includes efficient use of energy and natural resources, along with the minimization of CO<sub>2</sub> emissions.

#### Cost of ownership optimization through... Circular Performance

We're helping our customers optimize the total cost of ownership of their assets. To do this, we provide IoT-enabled solutions, as well as upgrade, repair, retrofit, and remanufacture services.

#### Peace of mind through... Well-being Performance

Green Premium products are RoHS and REACH compliant. We're going beyond regulatory compliance with step-by-step substitution of certain materials and substances from our products.

#### Improved sales through... Differentiation

Green Premium delivers strong value propositions through third-party labels and services. By collaborating with third-party organizations we can support our customers in meeting their sustainability goals such as green building certifications.

Tel: ۰۲۱-۴۸۰۰۰۰۴۹

Fax: ۰۲۱-۴۴۹۹۴۶۴۲

تهران، کیلومتر ۲۱ بزرگراه لشگری (جاده مخصوص کرج)

روبروی پالایشگاه نفت پارس، پلاک ۱۲





Multi9 has been designed to offer enhanced protection by preventing and protecting people and equipment from electrical threats such as short circuits, earth leakages, overloads and more

## A comprehensive range for enhanced protection against electrical threats.

Multi9™ is a range of DIN rail modular devices, a solution offering great performance. Multi9 range is built to meet the major standards for industry applications. Designed to meet your needs for most types of machines, Multi9 offers a wide range of modular devices providing protection, signalling functions and accessories.

### Renowned quality

World leader's proven technology and experience.

### Available worldwide

Sold under the same commercial reference.

### Optimized

Small footprint to reduce your panel size, cost effective, less commercial references.

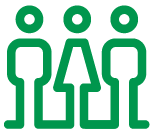

#### Multi-standard

Enhanced protection by preventing and protecting people and equipment from electrical threats such as short circuits, earth leakages, overloads and more.



#### Wide range of offers to cover all functions in a Control Panels

Wide range of solutions that are customized to fit your efficiency and sustainability needs.



#### Optimized References Which is easy to select

- Time-Saving
- Easy to procure and install
- Easy coordination
- Convenient maintenance and warranty



#### Sustainable with Green Premium Compliance

Certified to be sustainable and safe for the environment



## Multi-standard

### Multi9 - range with advanced protection

Designed to offer enhanced protection by preventing and protecting people and equipment from electrical threats such as short circuits, earth leakages, overloads and more.



#### Miniature Circuit Breakers

Protection against short circuits and overcurrent faults ensuring uninterrupted functionality.

- Ensures no accidental contact with live part – Finger-proof IP-20 terminals
- Avoids false insertion of cables and loose termination with Pull up terminals
- Total Flexibility : Line-Load reversibility
- Low cost with higher performance: Cascading. Cascading charts available From ACB-MCCB-MCB level.
- Reduce Downtime: Discrimination. Discrimination charts available From ACB-MCCB-MCB level
- Easy Installation: Bi – connect terminals
- Increased service life: Fast Closing mechanism
- Environmentally friendly with 100% recyclable & recoverable materials.

#### Surge Protection Devices

Surge protection, harmonic filtering and voltage regulation from home to the data center to industrial environments.

- Affordable – An affordable way to protect your infrastructure from potential hazards.
- Easy Repair & Replacement – Surge protectors protect your electrical devices from burnout and expand their lifespan.
- Reduced Maintenance Costs – Because surge protectors limit excessive voltage, they can protect your appliances, HVAC system, and more. Thus reducing the number of maintenance calls you make.

#### Residual Current Device

Safe and reliable protection against earth fault, fire protection and electrocution ensuring people's safety, delivering efficiency and service continuity.

- Easy monitoring: Earth fault indication on front face
- Immunity against nuisance tripping
- New SI RCDs offers enhanced immunity to electrical disturbances and polluted & corrosive environments
- Easy Installation: bi-connect terminals
- Field fittable auxiliaries for advanced protection & monitoring







## Wide range of offers to cover all functions in a Control Panels

Fully compliant with all industry standards, Multi9 is ideally suited for all types of machine and equipment, providing you not only with protection but plenty of accessories as well as signaling functions.



**Time saving**



**Easy to buy from same vendor and install**



**Easy coordination**



**Easy warranty and maintenance**



### PLC (Programmable Logic Controllers)

Control and monitor industrial operations in a sustainable, flexible, efficient and protected way. Our PLCs and PACs supply edge technology, augmenting it with Ethernet connectivity, built-in cybersecurity, and processing power needed to handle Big Data analysis and protect against new vulnerabilities among connected industrial assets, across devices or into the cloud.



### Push buttons

Ensure robust, safe, ergonomic and easy control of machines and manufacturing lines delivering efficiency and effectiveness.



### HMI

Simple and effective means of connecting systems, collecting data and presenting information. Perform diagnostics, add control and adjust system settings on simple or compact applications from the smallest text display to the most sophisticated industrial PC.



### Speed drives

Powerful and reliable combination for your motor control solutions made to the highest quality level to meet your needs in various applications, such as industrial processes, machines or buildings.



# Range Highlights

## C60BP



Miniature circuit breaker for Branch Protection

- UL 489, CSA, IEC and CCC certified,
- UL 489 performances: up to 35 A in 480Y/277V and up to 63 A in 240 V,
- New optimized design and smaller footprint (103 mm / 4,05 in): each references up to 35 A, cover both 480Y/277V and 240 V power supplies,
- In addition to the accessories range, the UL cuttable combs are now available.

## C60BPR

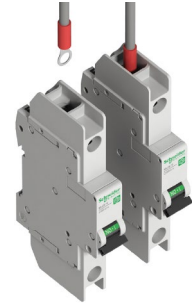

Miniature circuit breaker for Branch Protection with Ring terminal

- UL 489, CSA, IEC and CCC certified,
- UL 489 performances: up to 35 A in 480Y/277V and up to 63 A in 240 V,
- New optimized design and smaller footprint: each references up to 35 A cover both 480Y/277V and 240 V power supplies,
- Ring tongue terminal connection ability,
- Ready to wire as terminal are delivered open.

## C60SP



Miniature Circuit Breaker for Supplementary Protection

- UL 1077, CSA, IEC and CCC certified
- UL 1077 performances: up to 63A in 480 Y/277 V
- B, C & D curves

## C60N/H/L



Miniature Circuit Breaker for IEC zone

- IEC/EN 60947-2 and CCC certified
- Up to 20 kA (440 V)
- B, C & D curves

## C60H-DC



Miniature circuit breaker, "H" breaking capacity for Direct Current applications

- UL1077, IEC, CCC certified,
- To protect your direct current applications up to 500 V DC.

## Vigi C60



Residual Current Device

- IEC/EN 61009-1



# Range Highlights

## Surge Protection Devices



Surge protection, harmonic filtering and voltage regulation from home to the data center to industrial environments.

- UL 1449 4th Edition Recognized, CSA C22.2 No. 269.4-17, 1st Edition

## PowerTag Energy



PowerTag Energy is a wireless-communication energy sensor

PowerTag Energy is designed specifically for Energy Management, Load Monitoring and Power Availability applications.

Associated to a concentrator or a gateway, PowerTag Energy provides a full wireless class 1 solution to monitor energy at any level of a distribution panel.

Suitable for industrial and machine applications, PowerTag Energy sensor incorporates all features required to perform accurate real-time measurements (U, V, I, P, PF) and energy values up to 160 A.

Advantages:

- Wireless-communication
- Voltage loss alarming
- Class 1 accuracy
- Compact design
- Easy installation and commissioning
- Scalable solution
- Perfect for retrofit or new panels

See PowerLogic Catalog PLS3D309005EN



Click on  
QR code or scan  
to download



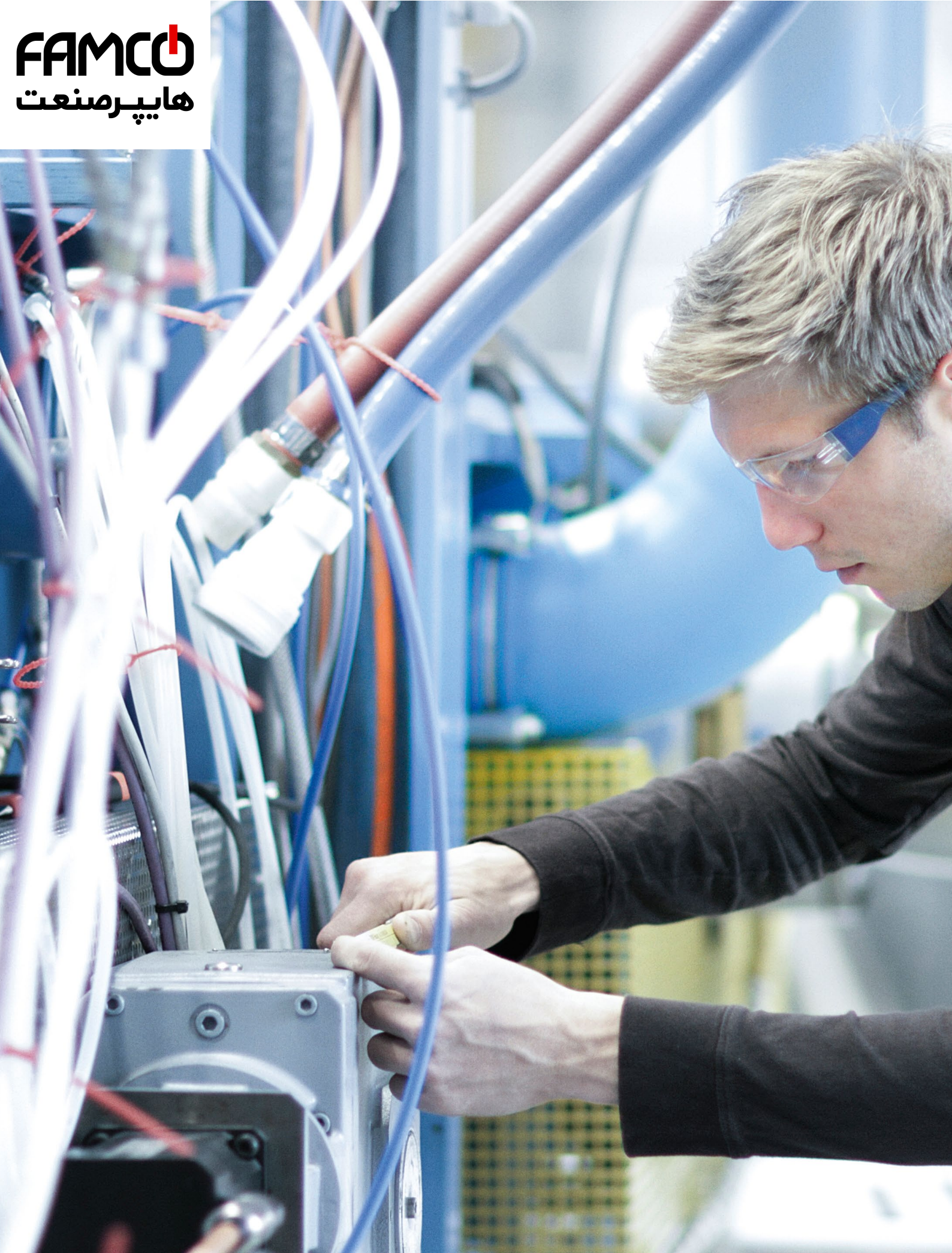



# Multi9

## Multistandard circuit protection for OEM

|   |           |          |
|---|-----------|----------|
| <b>Miniature Circuit Breakers</b>   | <b>12</b> | <b>1</b> |
| <a href="#">UL/CSA + IEC/EN 60947-2 + GB</a>                                | 12        |          |
| C60BP - UL 489 - Z, C, D curves – Tunnel terminals                          | 12        |          |
| C60BPR - UL 489 - Z, C, D curves – Ring-tongue terminals                    | 14        |          |
| C60sp - UL 1077 - B, C, D curves – Tunnels terminals                        | 16        |          |
| C60H-DC - UL 1077 - B, C, K curves – Tunnels terminals for DC circuits only | 19        |          |
| <a href="#">IEC/EN 60947-2</a>  | 22        |          |
| C60N - B, C, D curves   | 22        |          |
| C60H - B, C, D curves   | 24        |          |
| C60L - C curve  | 26        |          |
| C60CTRL - Z and C curves – For control circuits protection                  | 28        |          |
| N40N - C curve  | 30        |          |

|   |           |          |
|---|-----------|----------|
| <b>Residual current devices</b>   | <b>32</b> | <b>2</b> |
| <a href="#">UL + IEC/EN</a>   | 32        |          |
| GFP - UL 1053 & IEC/EN 61008 - Ground Fault Protector                                   | 32        |          |
| <a href="#">VDE + IEC/EN</a>  | 34        |          |
| Acti9 iLD B-SI type Residual Current Circuit Breakers (RCCB)                            | 34        |          |
| RCCB-ID 125 A Residual Current Circuit Breakers (AC, A, A-SI, B types)                  | 38        |          |
| <a href="#">IEC/EN</a>  | 42        |          |
| RCCB ID - IEC/EN 61008-1 – Residual Current Circuit Breakers – AC, A-SI types           | 42        |          |
| Vigi C60 - IEC/EN 61009-1 – Residual Current Devices – Add-on for C60                   | 44        |          |
| Vigi N40 - IEC/EN 61009-1 – Residual Current Devices – Add-on for N40                   | 46        |          |
| N40 Vigi - IEC/EN 61009-1 Residual Current circuit Breakers with Overcurrent protection | 48        |          |

|  |           |          |
|--|-----------|----------|
| <b>Surge Protective Devices</b>                              | <b>50</b> | <b>3</b> |
| <a href="#">UL 1449 4th Edition + CSA C22.2 No. 269.4-17</a> | 50        |          |
| Multi9 PRD1 75r  | 50        |          |

|   |           |          |
|---|-----------|----------|
| <b>Auxiliaries and accessories</b>                                      | <b>55</b> | <b>4</b> |
| Electrical auxiliaries for MCB and RCD, except Acti9 iLD B-SI type RCCB | 55        |          |
| Electrical auxiliaries for Acti9 iLD B-SI type RCCB                     | 61        |          |
| Accessories for MCB and RCD, except Acti9 iLD B-SI type RCCB            | 68        |          |
| Accessories for Acti9 iLD B-SI type RCCB                                | 73        |          |
| Comb busbars for C60BP (UL489)  | 78        |          |
| Comb busbars for C60sp (UL1077)   | 80        |          |
| Comb busbars for C60N, C60H, C60L (IEC/EN, 18 mm / 0.71 in pitch)       | 82        |          |
| Comb busbars for N40N, N40 Vigi (IEC/EN, 9 mm / 0.35 in pitch)          | 84        |          |
| Linergy DS screw distribution blocks                                    | 86        |          |

|   |           |          |
|---|-----------|----------|
| <b>Technical information</b>                                  | <b>90</b> | <b>5</b> |
| <a href="#">Breaker standards</a>                             | 90        |          |
| <a href="#">The standards and their applications</a>          | 91        |          |
| <a href="#">Circuit breakers tripping curves</a>              | 92        |          |
| <a href="#">Influence of ambient temperature</a>              | 96        |          |
| <a href="#">Dissipated power, Impedance and Voltage drop</a>  | 100       |          |
| <a href="#">Short-circuit current limiting</a>                | 101       |          |
| <a href="#">Clearance between device and bare sheet metal</a> | 108       |          |
| <a href="#">Copper Multi-cables connection</a>                | 109       |          |

|   |            |          |
|---|------------|----------|
| <b>Control panel technical guides library</b> | <b>111</b> | <b>6</b> |
|---|------------|----------|



#### UL 489 / CSA C22.2 No 5 / IEC/EN 60947-2 / GB 14048-2

As per the above standards:

C60BP are multi-standard miniature circuit breakers and branch circuit protection as defined by UL 489. It combines following functions:

- circuit protection against short-circuit currents
- circuit protection against overload currents
- tripping and electrical fault indication by the addition of auxiliaries.



| Number of 18 mm (0.71 in) poles | Rating (A) 25°C/77°F | Breaking capacity (kA rms) AIR |         |         |           | Icu         |         |         |           |
|---------------------------------|----------------------|--------------------------------|---------|---------|-----------|-------------|---------|---------|-----------|
|                                 |                      | UL 489 / CSA C22.2 No 5        |         |         |           | IEC 60947-2 |         |         |           |
| 1P                              | 0.5 to 35            | 277 V ~                        | 240 V ~ | 120 V ~ | 60 V ---  | 440 V ~     | 415 V ~ | 240 V ~ | 60 V ---  |
|                                 | 40 to 63             | -                              | 10      | 10      | 10        | -           | 3       | 10      | 20        |
| 2P                              | 1 to 25              | 480Y/277 V ~                   |         | 240 V ~ | 125 V --- | 440 V ~     | 415 V ~ | 240 V ~ | 125 V --- |
|                                 | 30 to 35             | 10                             | 10      | 14      | 10        | 6           | 10      | 20      | 10        |
| 3P                              | 1 to 35              | 10                             | -       | 14      | -         | 6           | 10      | 20      | -         |
| 2P/3P                           | 40 to 63             | -                              | 10      | -       | -         | 6           | 10      | 20      | -         |



#### Electrical diagrams

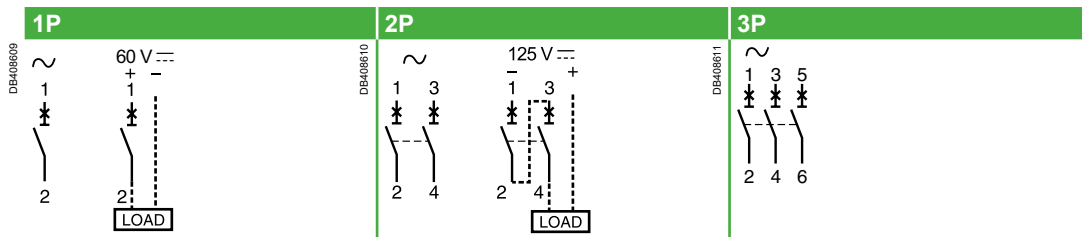

#### Catalog numbers

| Tunnel terminal connection |                        |   |          |          |                                 |          |          |                                 |          |          |                                 |
|----------------------------|------------------------|---|----------|----------|---------------------------------|----------|----------|---------------------------------|----------|----------|---------------------------------|
| Type                       | UL489 and CSA voltages | 1P  |          |          | 2P                              |          |          | 3P                              |          |          |                                 |
| Rating (In)                |                        | Curve                                       |          |          | Width in 9 mm (0.35 in) modules | Curve    |          | Width in 9 mm (0.35 in) modules | Curve    |          | Width in 9 mm (0.35 in) modules |
|                            |                        | Z   | C        | D (=K)   |                                 | C        | D (=K)   |                                 | C        | D (=K)   |                                 |
| <b>C60BP</b>               |                        |   |          |          |                                 |          |          |                                 |          |          |                                 |
| 0.5                        | 480Y/277 V and 240 V   | M9F44170                                    | M9F42170 | M9F43170 | 2                               | -        | -        | 4                               | -        | -        | 6                               |
| 1                          |                        | M9F44101                                    | M9F42101 | M9F43101 |                                 | M9F42201 | M9F43201 |                                 | M9F42301 | M9F43301 |                                 |
| 2                          |                        | M9F44102                                    | M9F42102 | M9F43102 |                                 | M9F42202 | M9F43202 |                                 | M9F42302 | M9F43302 |                                 |
| 3                          |                        | M9F44103                                    | M9F42103 | M9F43103 |                                 | M9F42203 | M9F43203 |                                 | M9F42303 | M9F43303 |                                 |
| 4                          |                        | M9F44104                                    | M9F42104 | M9F43104 |                                 | M9F42204 | M9F43204 |                                 | M9F42304 | M9F43304 |                                 |
| 5                          |                        | M9F44105                                    | M9F42105 | M9F43105 |                                 | M9F42205 | M9F43205 |                                 | M9F42305 | M9F43305 |                                 |
| 6                          |                        | M9F44106                                    | M9F42106 | M9F43106 |                                 | M9F42206 | M9F43206 |                                 | M9F42306 | M9F43306 |                                 |
| 7                          |                        | -   | M9F42107 | -        |                                 | M9F42207 | -        |                                 | -        | -        |                                 |
| 8                          |                        | M9F44108                                    | M9F42108 | M9F43108 |                                 | M9F42208 | M9F43208 |                                 | M9F42308 | M9F43308 |                                 |
| 10                         |                        | M9F44110                                    | M9F42110 | M9F43110 |                                 | M9F42210 | M9F43210 |                                 | M9F42310 | M9F43310 |                                 |
| 13                         |                        | -   | M9F42113 | -        |                                 | M9F42213 | -        |                                 | -        | -        |                                 |
| 15                         |                        | M9F44115                                    | M9F42115 | M9F43115 |                                 | M9F42215 | M9F43215 |                                 | M9F42315 | M9F43315 |                                 |
| 20                         |                        | M9F44120                                    | M9F42120 | M9F43120 |                                 | M9F42220 | M9F43220 |                                 | M9F42320 | M9F43320 |                                 |
| 25                         | M9F44125               | M9F42125                                    | M9F43125 |          | M9F42225                        | M9F43225 |          | M9F42325                        | M9F43325 |          |                                 |
| 30                         | M9F44130               | M9F42130                                    | M9F43130 |          | M9F42230                        | M9F43230 |          | M9F42330                        | M9F43330 |          |                                 |
| 35                         | M9F44135               | M9F42135                                    | M9F43135 |          | M9F42235                        | M9F43235 |          | M9F42335                        | M9F43335 |          |                                 |
| 40                         | 240 V only             | M9F44140                                    | M9F42140 | M9F43140 | 2                               | M9F42240 | M9F43240 | 4                               | M9F42340 | M9F43340 | 6                               |
| 45                         |                        | M9F44145                                    | M9F42145 | -        |                                 | M9F42245 | -        |                                 | M9F42345 | -        |                                 |
| 50                         |                        | M9F44150                                    | M9F42150 | -        |                                 | M9F42250 | -        |                                 | M9F42350 | -        |                                 |
| 55                         |                        | M9F44155                                    | M9F42155 | -        |                                 | M9F42255 | -        |                                 | M9F42355 | -        |                                 |
| 63                         |                        | M9F44163                                    | M9F42163 | -        |                                 | M9F42263 | -        |                                 | M9F42363 | -        |                                 |
| <b>Auxiliaries</b>         |                        | Remote indication and tripping, see page 55 |          |          |                                 |          |          |                                 |          |          |                                 |



#### Conformity with product standards

- UL 489 branch circuit protection, document #E215117.
- CSA C22.2 No 5 branch circuit protection, document #E179014.
- IEC/EN 60947-2.
- GB 14048-2.

#### UL 486A connections for copper cables, document #E216919

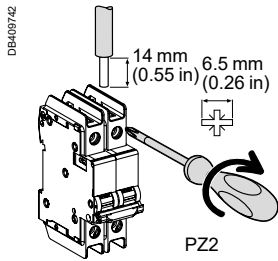

| Rating      | Tightening torque  | Without accessory               |               |
|-------------|--------------------|---------------------------------|---------------|
|             |                    | Copper cables (*)               |               |
|             |                    | Rigid, flexible or with ferrule |               |
| 0.5 to 25 A | 2.5 N.m (22 lb.in) | IEC 60947-2                     | UL 486A-B     |
| 30 to 63 A  | 3.5 N.m (31 lb.in) | 1 to 25 mm <sup>2</sup>         | AWG #18 to #8 |
|             |                    | 1 to 35 mm <sup>2</sup>         | AWG #18 to #2 |

(\*) See Copper Multi-cable connection chapter for more information, page 109.

#### Weight (g / oz)

| Circuit breaker |                  |
|-----------------|------------------|
| Type            | C60BP            |
| 1P              | 130 g / 4.58 oz  |
| 2P              | 260 g / 9.17 oz  |
| 3P              | 390 g / 13.76 oz |

#### Technical data

| Main characteristics                   |                        |                        |               |
|--|------------------------|------------------------|---------------|
| Insulation voltage (Ui)                |                        |                        | 500 V         |
| Service breaking capacity (Ics)        | In alternating current |                        | 75 % of Icu   |
|  | In direct current      |                        | 100 % of Icu  |
| Pollution degree                       |                        |                        | 3             |
| Rated impulse withstand voltage (Uimp) |                        |                        | 6 kV          |
| Thermal tripping                       | Reference temperature  |                        | 25°C / 77°F   |
| Magnetic tripping                      | Z curve                | In alternating current | 3 In ± 20 %   |
|  |                        | In direct current      | 4.2 In ± 20 % |
|  | C curve                | In alternating current | 8.5 In ± 20 % |
|  |                        | In direct current      | 12 In ± 20 %  |
|  | D curve (=K curve)     | In alternating current | 12 In ± 20 %  |
|  |                        | In direct current      | 17 In ± 20 %  |

#### Dimensions (mm / inches)

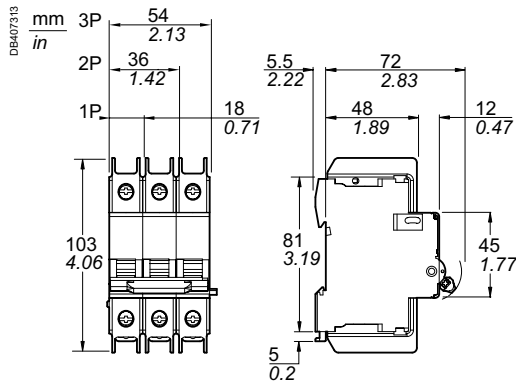

C60BP Tunnel terminal

| Additional characteristics                   |                             |  |
|--|-----------------------------|--|
| Degree of protection Device only (IEC 60529) | Device only                 | IP20   |
|  | Device in modular enclosure | IP40   |
| Endurance (O-C)                              | Electrical                  | 10,000 cycles  |
|  | Mechanical                  | 20,000 cycles  |
| Operating temperature                        |                             | -30°C to +70°C / -22°F to 158°F                      |
| Storage temperature                          |                             | -40°C to +80°C / -40°F to 176°F                      |
| Tropicalization (IEC 60068-1)                |                             | Treatment 2 (relative humidity 95 % at 55°C / 131°F) |
| Dissipated power                             |                             | See page 100   |

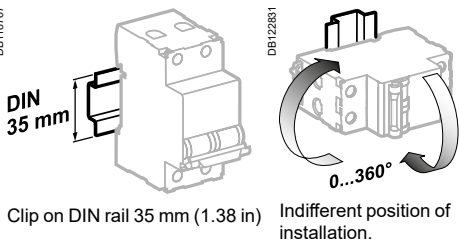

Clip on DIN rail 35 mm (1.38 in) Indifferent position of installation.

#### Railways

| Type  | 1P  | 2P               | 3P                |
|---|---|------------------|-------------------|
| Mass of combustible material                    | 46.4 g / 1.64 oz  | 93.8 g / 3.31 oz | 139.2 g / 4.91 oz |
| Type of combustible material                    | PA66 GF25 FR  |                  |                   |
| Fire and smoke requirements (EN 45545-2)        | HL3 R22 / HL3 R23   |                  |                   |
| Resistance to shocks and vibrations (IEC 61373) | <ul style="list-style-type: none"> <li>■ Category 1</li> <li>■ Class B</li> </ul> |                  |                   |

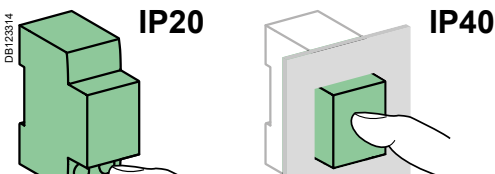

DB10527



DB10528



DB40527



#### UL 489 / CSA C22.2 No 5 / IEC/EN 60947-2 / GB 14048-2

As per the above standards:

C60BPR are multi-standard miniature circuit breakers and branch circuit protection as defined by UL 489. It combines following functions:

- circuit protection against short-circuit currents
- circuit protection against overload currents
- tripping and electrical fault indication by the addition of auxiliaries
- IP2X ring tongue terminal connection.



| Number of poles | Rating (A) 25°C/77°F | Breaking capacity (kA rms) AIR |         |         |           | Icu         |         |         |           |
|-----------------|----------------------|--------------------------------|---------|---------|-----------|-------------|---------|---------|-----------|
|                 |                      | UL 489 / CSA C22.2 No 5        |         |         |           | IEC 60947-2 |         |         |           |
|                 | Voltage (Ue)         | 277 V ~                        | 240 V ~ | 120 V ~ | 60 V ---  | 440 V ~     | 415 V ~ | 240 V ~ | 60 V ---  |
| 1P              | 1 to 35              | 10                             | 14      | 14      | 10        | -           | 3       | 10      | 20        |
|                 | 40 to 63             | -                              | 10      | 10      | 10        | -           | 3       | 10      | 20        |
| 2P              | 1 to 25              | 480Y/277 V ~                   |         | 240 V ~ | 125 V --- | 440 V ~     | 415 V ~ | 240 V ~ | 125 V --- |
|                 | 30 to 35             | 10                             | 14      | 10      | 10        | 6           | 10      | 20      | 10        |
| 3P              | 1 to 35              | 10                             | 14      | -       | -         | 6           | 10      | 20      | -         |
| 2P/3P           | 40 to 63             | -                              | 10      | □       | -         | 6           | 10      | 20      | -         |



#### Electrical diagrams

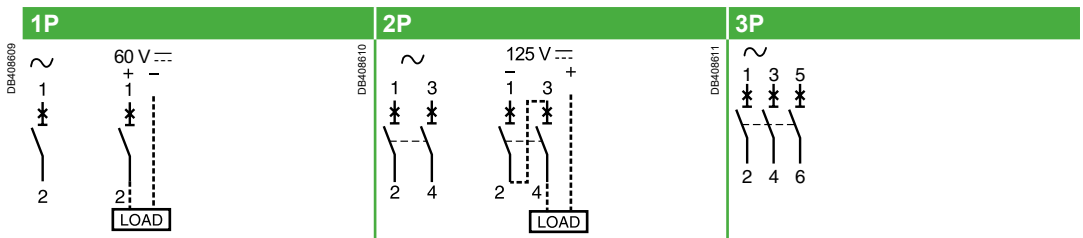

#### Catalog numbers

| Ring tongue terminal connection |                        |          |          |          |                                 |          |          |                                 |          |          |                                 |
|---------------------------------|------------------------|----------|----------|----------|---------------------------------|----------|----------|---------------------------------|----------|----------|---------------------------------|
| Type                            | UL489 and CSA voltages | 1P       |          |          | 2P                              |          |          | 3P                              |          |          |                                 |
| Rating (In)                     |                        | Curve    |          |          | Width in 9 mm (0.35 in) modules | Curve    |          | Width in 9 mm (0.35 in) modules | Curve    |          | Width in 9 mm (0.35 in) modules |
|                                 |                        | Z        | C        | D (=K)   |                                 | C        | D (=K)   |                                 | C        | D (=K)   |                                 |
| <b>C60BPR</b>                   |                        |          |          |          |                                 |          |          |                                 |          |          |                                 |
| 1                               | 480Y/277 V and 240 V   | M9F54101 | M9F52101 | M9F53101 | 2                               | M9F52201 | M9F53201 | 4                               | M9F52301 | M9F53301 | 6                               |
| 2                               |                        | M9F54102 | M9F52102 | M9F53102 |                                 | M9F52202 | M9F53202 |                                 | M9F52302 | M9F53302 |                                 |
| 4                               |                        | M9F54104 | M9F52104 | M9F53104 |                                 | M9F52204 | M9F53204 |                                 | M9F52304 | M9F53304 |                                 |
| 6                               |                        | M9F54106 | M9F52106 | M9F53106 |                                 | M9F52206 | M9F53206 |                                 | M9F52306 | M9F53306 |                                 |
| 8                               |                        | M9F54108 | M9F52108 | M9F53108 |                                 | M9F52208 | M9F53208 |                                 | M9F52308 | M9F53308 |                                 |
| 10                              |                        | M9F54110 | M9F52110 | M9F53110 |                                 | M9F52210 | M9F53210 |                                 | M9F52310 | M9F53310 |                                 |
| 15                              |                        | M9F54115 | M9F52115 | M9F53115 |                                 | M9F52215 | M9F53215 |                                 | M9F52315 | M9F53315 |                                 |
| 20                              |                        | M9F54120 | M9F52120 | M9F53120 |                                 | M9F52220 | M9F53220 |                                 | M9F52320 | M9F53320 |                                 |
| 25                              |                        | M9F54125 | M9F52125 | M9F53125 |                                 | M9F52225 | M9F53225 |                                 | M9F52325 | M9F53325 |                                 |
| 30                              |                        | M9F54130 | M9F52130 | M9F53130 |                                 | M9F52230 | M9F53230 |                                 | M9F52330 | M9F53330 |                                 |
| 35                              | M9F54135               | M9F52135 | M9F53135 | M9F52235 | M9F53235                        | M9F52335 | M9F53335 |                                 |          |          |                                 |
| 40                              | 240 V only             | M9F54140 | M9F52140 | M9F53140 | 2                               | M9F52240 | M9F53240 | 4                               | M9F52340 | M9F53340 | 6                               |
| 45                              |                        | M9F54145 | M9F52145 | -        |                                 | M9F52245 | -        |                                 | M9F52345 | -        |                                 |
| 50                              |                        | M9F54150 | M9F52150 | -        |                                 | M9F52250 | -        |                                 | M9F52350 | -        |                                 |
| 55                              |                        | M9F54155 | M9F52155 | -        |                                 | M9F52255 | -        |                                 | M9F52355 | -        |                                 |
| 63                              |                        | M9F54163 | M9F52163 | -        |                                 | M9F52263 | -        |                                 | M9F52363 | -        |                                 |

Auxiliaries Remote indication and tripping: see page 55



#### Conformity with product standards

- UL 489 branch circuit protection, document #E215117.
- CSAC22.2 No 5 branch circuit protection, document #E179014.
- IEC/EN 60947-2.
- GB 14048-2.

#### UL 486A connections for copper wires, document #E216919

##### With accessory

| Rating    | Tightening torque | Screw-on connection for ring terminal   |
|-----------|-------------------|---|
| 1 to 63 A | 2 N.m (18 lb.in)  | <p>A: Ø 6 mm (Ø 0.24 in)<br/>           B: 12 mm +0.4/-2 (0.47 in +0.02/-0.08)<br/>           C: 7.15 mm (0.28 in) minimum value<br/>           D: 3 mm (0.12 in) maxi<br/>           or<br/>           E: 2 x 1.5 mm (2 x 0.06 in)</p> |

Note: Please check instruction sheet QGH7334601 for proper cable insertion

#### Weight (g / oz)

| Circuit breaker |                  |
|-----------------|------------------|
| Type            | C60BPR           |
| 1P              | 130 g / 4.58 oz  |
| 2P              | 260 g / 9.17 oz  |
| 3P              | 390 g / 13.76 oz |

#### Dimensions

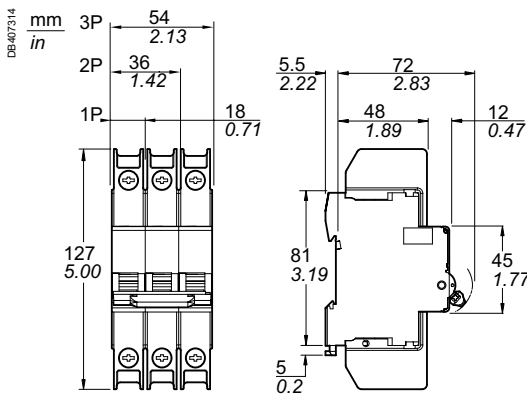

C60BPR Ring tongue terminal

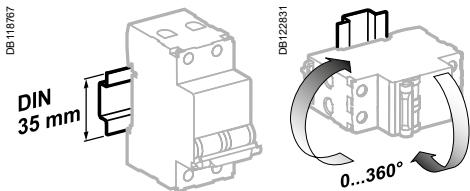

Clip on DIN rail 35 mm (1.38 in) Indifferent position of installation.

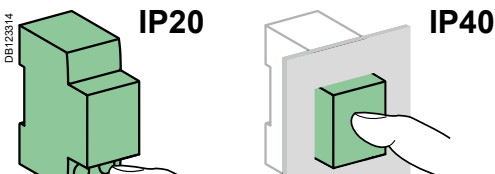

#### Technical data

##### Main characteristics

|  |               |
|--|---------------|
| Insulation voltage (Ui)                                | 500 V         |
| Service breaking capacity (Ics) In alternating current | 75 % of Icu   |
| In direct current                                      | 100 % of Icu  |
| Pollution degree                                       | 3             |
| Rated impulse withstand voltage (Uimp)                 | 6 kV          |
| Thermal tripping Reference temperature                 | 25°C / 77°F   |
| Magnetic tripping Z curve In alternating current       | 3 In ± 20 %   |
| In direct current                                      | 4.2 In ± 20 % |
| C curve In alternating current                         | 8.5 In ± 20 % |
| In direct current                                      | 12 In ± 20 %  |
| D curve In alternating current                         | 12 In ± 20 %  |
| (=K curve) In direct current                           | 17 In ± 20 %  |

##### Additional characteristics

|  |  |
|--|--|
| Degree of protection Device only (IEC 60529) | IP20   |
| Device in modular enclosure                  | IP40   |
| Insulation class II                          |  |
| Endurance (O-C) Electrical                   | 10,000 cycles  |
| Mechanical                                   | 20,000 cycles  |
| Operating temperature                        | -30°C to +70°C / -22°F to 158°F                      |
| Storage temperature                          | -40°C to +80°C / -40°F to 176°F                      |
| Tropicalization (IEC 60068-1)                | Treatment 2 (relative humidity 95 % at 55°C / 131°F) |
| Dissipated power                             | See page 100   |

#### Railways



| Type  | 1P  | 2P               | 3P                |
|---|---|------------------|-------------------|
| Mass of combustible material                    | 46.4 g / 1.64 oz  | 93.8 g / 3.31 oz | 139.2 g / 4.91 oz |
| Type of combustible material                    | PA66 GF25 FR  |                  |                   |
| Fire and smoke requirements (EN 45545-2)        | HL3 R22 / HL3 R23   |                  |                   |
| Resistance to shocks and vibrations (IEC 61373) | <ul style="list-style-type: none"> <li>■ Category 1</li> <li>■ Class B</li> </ul> |                  |                   |



UL 1077 / CSA C22.2 No 235 / IEC/EN 60947-2 / GB 14048-2

As per the above standards:

C60SP are multi-standard miniature circuit breakers and supplementary protection as defined by UL 1077. It combines following functions:

- circuit protection against short-circuit currents
- circuit protection against overload currents
- tripping and electrical fault indication by the addition of auxiliaries.



| Number of 18 mm (0.71 in) poles | Rating (A) 25°C/77°F | Breaking capacity (kA rms) AIR |         |         |         | Icu         |         |         |         |
|---------------------------------|----------------------|--------------------------------|---------|---------|---------|-------------|---------|---------|---------|
|                                 |                      | UL 1077 / CSA C22.2 No 235     |         |         |         | IEC 60947-2 |         |         |         |
| 1P                              | 0.5 to 32            | 277 V ~                        | 240 V ~ | 120 V ~ | 65 V ~  | 440 V ~     | 415 V ~ | 240 V ~ | 60 V ~  |
|                                 | 40 to 63             | 10                             | 14      | 14      | 10      | -           | 3       | 10      | 20      |
| 2P                              | 1 to 25              | 480Y/277 V ~                   |         | 240 V ~ | 125 V ~ | 440 V ~     | 415     | 240 V ~ | 125 V ~ |
|                                 | 32                   | 10                             | 14      | 14      | 10      | 6           | 10      | 20      | 10      |
| 3P/4P                           | 2 to 32              | 10                             | 14      | -       | -       | 6           | 10      | 20      | -       |
| 2P/3P/4P                        | 40 to 63             | 5                              | 10      | 10      | 10      | 6           | 10      | 20      | -       |

### Electrical diagrams

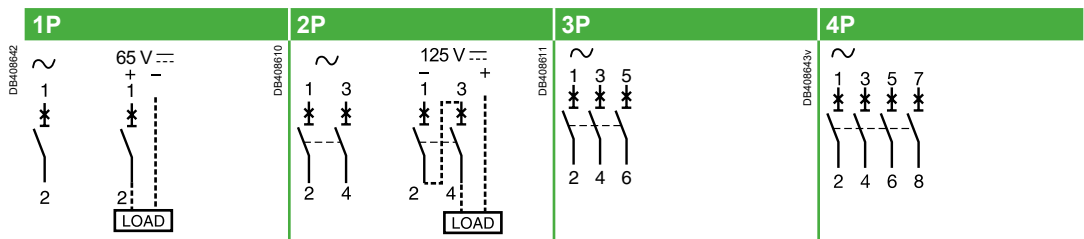

### Catalog numbers

| Tunnel terminal connection |          |          |          |                                 |          |          |          |                                 |
|----------------------------|----------|----------|----------|---------------------------------|----------|----------|----------|---------------------------------|
| Type                       | 1P       |          |          | Width in 9 mm (0.35 in) modules | 2P       |          |          | Width in 9 mm (0.35 in) modules |
| Rating (In)                | Curve    | B        | C        |                                 | D (=K)   | Curve    | B        |                                 |
| <b>C60SP</b>               |          |          |          |                                 |          |          |          |                                 |
| 0.5                        | M9F21170 | M9F22170 | M9F23170 | 2                               | -        | -        | -        | 4                               |
| 1                          | M9F21101 | M9F22101 | M9F23101 |                                 | M9F21201 | M9F22201 | M9F23201 |                                 |
| 2                          | M9F21102 | M9F22102 | M9F23102 |                                 | M9F21202 | M9F22202 | M9F23202 |                                 |
| 3                          | M9F21103 | M9F22103 | M9F23103 |                                 | M9F21203 | M9F22203 | M9F23203 |                                 |
| 4                          | M9F21104 | M9F22104 | M9F23104 |                                 | M9F21204 | M9F22204 | M9F23204 |                                 |
| 5                          | M9F21105 | M9F22105 | M9F23105 |                                 | M9F21205 | M9F22205 | M9F23205 |                                 |
| 6                          | M9F21106 | M9F22106 | M9F23106 |                                 | M9F21206 | M9F22206 | M9F23206 |                                 |
| 8                          | M9F21108 | M9F22108 | M9F23108 |                                 | M9F21208 | M9F22208 | M9F23208 |                                 |
| 10                         | M9F21110 | M9F22110 | M9F23110 |                                 | M9F21210 | M9F22210 | M9F23210 |                                 |
| 13                         | M9F21113 | M9F22113 | M9F23113 |                                 | M9F21213 | M9F22213 | M9F23213 |                                 |
| 16                         | M9F21116 | M9F22116 | M9F23116 |                                 | M9F21216 | M9F22216 | M9F23216 |                                 |
| 20                         | M9F21120 | M9F22120 | M9F23120 |                                 | M9F21220 | M9F22220 | M9F23220 |                                 |
| 25                         | M9F21125 | M9F22125 | M9F23125 |                                 | M9F21225 | M9F22225 | M9F23225 |                                 |
| 32                         | M9F21132 | M9F22132 | M9F23132 |                                 | M9F21232 | M9F22232 | M9F23232 |                                 |
| 40                         | M9F21140 | M9F22140 | M9F23140 |                                 | M9F21240 | M9F22240 | M9F23240 |                                 |
| 45                         | M9F21145 | M9F22145 | -        |                                 | M9F21245 | M9F22245 | -        |                                 |
| 50                         | M9F21150 | M9F22150 | -        | M9F21250                        | M9F22250 | -        |          |                                 |
| 63                         | M9F21163 | M9F22163 | -        | M9F21263                        | M9F22263 | -        |          |                                 |

Auxiliaries Remote indication and tripping, see page 55



#### Conformity with product standards

- UL 1077 supplementary protection , document #E90509.
- CSA C22.2 No. 235 supplementary protection, document #E179014.
- IEC/EN 60947-2.
- GB 14048-2.

#### UL 486A connections for copper cables, document #E216919

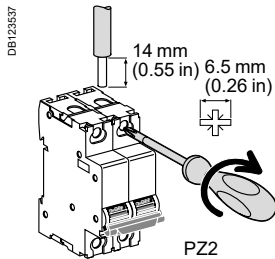

#### Without accessory

| Rating      | Tightening torque  | Copper cables (*)               |               |
|-------------|--------------------|---------------------------------|---------------|
|             |                    | Rigid, flexible or with ferrule |               |
| 0.5 to 25 A | 2.5 N.m (22 lb.in) | IEC 60947-2                     | UL 486A-B     |
| 30 to 63 A  | 3.5 N.m (31 lb.in) | 1 to 25 mm <sup>2</sup>         | AWG #18 to #8 |
|             |                    | 1 to 35 mm <sup>2</sup>         | AWG #18 to #2 |

(\*) See Copper Multi-cable connection chapter for more information, page 109.

#### Weight (g / oz)

| Circuit-breaker |                  |
|-----------------|------------------|
| Type            | C60SP            |
| 1P              | 120 g / 4.23 oz  |
| 2P              | 240 g / 8.46 oz  |
| 3P              | 360 g / 12.70 oz |
| 4P              | 480 g / 16.93 oz |

#### Dimensions (mm / inches)

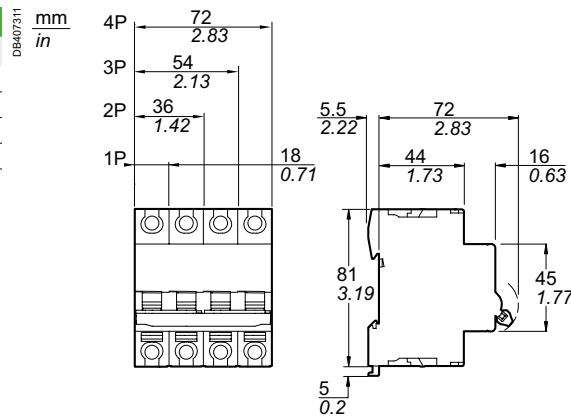

C60SP Tunnel terminal connection

| 3P       |          |          |                                 | 4P       |          |          |                                 |
|----------|----------|----------|---------------------------------|----------|----------|----------|---------------------------------|
| Curve    |          |          | Width in 9 mm (0.35 in) modules | Curve    |          |          | Width in 9 mm (0.35 in) modules |
| B        | C        | D (=K)   |                                 | B        | C        | D (=K)   |                                 |
| -        | -        | -        | 6                               | -        | -        | -        | 8                               |
| -        | -        | -        |                                 | -        | -        | -        |                                 |
| M9F21302 | M9F22302 | M9F23302 |                                 | M9F21402 | M9F22402 | M9F23402 |                                 |
| -        | -        | -        |                                 | -        | -        | -        |                                 |
| -        | -        | -        |                                 | -        | -        | -        |                                 |
| -        | -        | -        |                                 | -        | -        | -        |                                 |
| M9F21306 | M9F22306 | M9F23306 |                                 | M9F21406 | M9F22406 | M9F23406 |                                 |
| M9F21308 | M9F22308 | M9F23308 |                                 | M9F21408 | M9F22408 | M9F23408 |                                 |
| M9F21310 | M9F22310 | M9F23310 |                                 | M9F21410 | M9F22410 | M9F23410 |                                 |
| M9F21313 | M9F22313 | M9F23313 |                                 | M9F21413 | M9F22413 | M9F23413 |                                 |
| M9F21316 | M9F22316 | M9F23316 |                                 | M9F21416 | M9F22416 | M9F23416 |                                 |
| M9F21320 | M9F22320 | M9F23320 |                                 | M9F21420 | M9F22420 | M9F23420 |                                 |
| M9F21325 | M9F22325 | M9F23325 |                                 | M9F21425 | M9F22425 | M9F23425 |                                 |
| M9F21332 | M9F22332 | M9F23332 |                                 | M9F21432 | M9F22432 | M9F23432 |                                 |
| M9F21340 | M9F22340 | M9F23340 |                                 | M9F21440 | M9F22440 | M9F23440 |                                 |
| M9F21345 | M9F22345 | -        |                                 | M9F21445 | M9F22445 | -        |                                 |
| M9F21350 | M9F22350 | -        | M9F21450                        | M9F22450 | -        |          |                                 |
| M9F21363 | M9F22363 | -        | M9F21463                        | M9F22463 | -        |          |                                 |

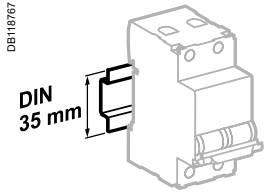

Clip on DIN rail 35 mm (1.38 in)

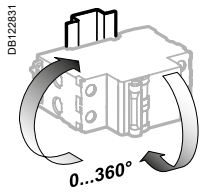

Indifferent position of installation.

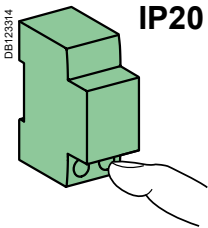

IP20

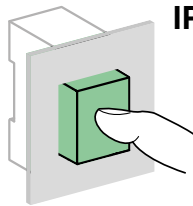

IP40

## Technical data

### Main characteristics

|  |                                   |                        |               |
|--|-----------------------------------|------------------------|---------------|
| Insulation voltage (Ui)                | 500 V                             |                        |               |
| Service breaking capacity (Ics)        | In alternating current            | 75 % of Icu            |               |
|  | In direct current                 | 100 % of Icu           |               |
| Pollution degree                       | 3                                 |                        |               |
| Rated impulse withstand voltage (Uimp) | 6 kV                              |                        |               |
| Thermal tripping                       | Reference temperature 25°C / 77°F |                        |               |
| Magnetic tripping                      | B curve                           | In alternating current | 4 In ± 20 %   |
|  |                                   | In direct current      | 5.7 In ± 20 % |
|  | C curve                           | In alternating current | 8.5 In ± 20 % |
|  |                                   | In direct current      | 12 In ± 20 %  |
|  | D curve<br>(=K curve)             | In alternating current | 12 In ± 20 %  |
|  |                                   | In direct current      | 17 In ± 20 %  |

### Additional characteristics

|                                  |   |               |
|----------------------------------|---|---------------|
| Degree of protection (IEC 60529) | Device only   | IP20          |
|                                  | Device in modular enclosure                             | IP40          |
| Endurance (O-C)                  | Electrical  | 10,000 cycles |
|                                  | Mechanical  | 20,000 cycles |
| Operating temperature            | -30°C to +70°C / -22°F to 158°F                         |               |
| Storage temperature              | -40°C to +80°C / -40°F to 176°F                         |               |
| Tropicalization (IEC 60068-1)    | Treatment 2<br>(relative humidity 95 % at 55°C / 131°F) |               |
| Dissipated power                 | See page 100  |               |

## Railways



| Type  | 1P  | 2P                  | 3P                   | 4P                   |
|---|---|---------------------|----------------------|----------------------|
| Mass of combustible material                    | 46.4 g /<br>1.64 oz   | 93.8 g /<br>3.31 oz | 139.2 g /<br>4.91 oz | 185.6 g /<br>6.55 oz |
| Type of combustible material                    | PA66 GF25 FR  |                     |                      |                      |
| Fire and smoke requirements (EN 45545-2)        | HL3 R22 / HL3 R23   |                     |                      |                      |
| Resistance to shocks and vibrations (IEC 61373) | <input checked="" type="checkbox"/> Category 1<br><input checked="" type="checkbox"/> Class B |                     |                      |                      |



for DC circuits only



### IEC/EN 60947-2, GB 14048.2, UL1077

As per the above standards:

C60H-DC are multi-standard miniature circuit breakers and supplementary protection as defined by UL 1077 dedicated to direct current. It combines following functions:

- circuit protection against short-circuit currents,
- circuit protection against overload currents,
- tripping and electrical fault indication by the addition of auxiliaries.



| Number of 18 mm (0.71 in) poles | Rating (A) 25°C/77°F | Breaking capacity (kA rms) |                  |                  |                  |                  |
|---------------------------------|----------------------|----------------------------|------------------|------------------|------------------|------------------|
|                                 |                      | AIR UL 1077                | Icu IEC 60947-2  |                  |                  |                  |
| <b>Voltage (Ue)</b>             |                      | <b>12...250 V</b> ---      | <b>110 V</b> --- | <b>220 V</b> --- | <b>250 V</b> --- |                  |
| 1P                              | 0.5 to 63            | 5                          | 20               | 10               | 6                |                  |
| <b>Voltage (Ue)</b>             |                      | <b>12...500 V</b> ---      |                  | <b>220 V</b> --- | <b>440 V</b> --- | <b>500 V</b> --- |
| 2P                              | 0.5 to 63            | 5                          | -                | 20               | 10               | 6                |



### Electrical diagrams

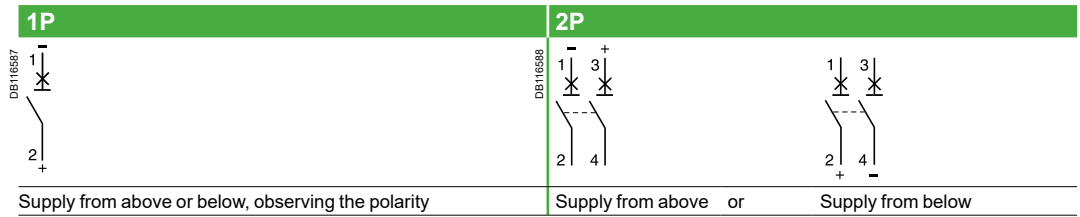

### Catalog numbers

| C60 <sub>H-DC</sub>       |   |          |          |                                 |          |          |          |                                 |  |
|---------------------------|---|----------|----------|---------------------------------|----------|----------|----------|---------------------------------|--|
| Type                      | 1P  |          |          |                                 | 2P       |          |          |                                 |  |
|                           | Curve                                       |          |          | Width in 9 mm (0.35 in) modules | Curve    |          |          | Width in 9 mm (0.35 in) modules |  |
| Rating (In)               | B   | C        | D (=K)   |                                 | B        | C        | D (=K)   |                                 |  |
| <b>C60<sub>H-DC</sub></b> |   |          |          |                                 |          |          |          |                                 |  |
| 0.5                       | -   | M9U21170 | -        | 2                               | -        | M9U21270 | -        | 4                               |  |
| 1                         | -   | M9U21101 | M9U31101 |                                 | -        | M9U21201 | M9U31201 |                                 |  |
| 2                         | -   | M9U21102 | M9U31102 |                                 | -        | M9U21202 | M9U31202 |                                 |  |
| 3                         | -   | M9U21103 | M9U31103 |                                 | -        | M9U21203 | M9U31203 |                                 |  |
| 4                         | -   | M9U21104 | M9U31104 |                                 | -        | M9U21204 | M9U31204 |                                 |  |
| 6                         | M9U11106                                    | M9U21106 | M9U31106 |                                 | M9U11206 | M9U21206 | M9U31206 |                                 |  |
| 10                        | M9U11110                                    | M9U21110 | M9U31110 |                                 | M9U11210 | M9U21210 | M9U31210 |                                 |  |
| 13                        | M9U11113                                    | M9U21113 | M9U31113 |                                 | M9U11213 | M9U21213 | M9U31213 |                                 |  |
| 16                        | M9U11116                                    | M9U21116 | M9U31116 |                                 | M9U11216 | M9U21216 | M9U31216 |                                 |  |
| 20                        | M9U11120                                    | M9U21120 | M9U31120 |                                 | M9U11220 | M9U21220 | M9U31220 |                                 |  |
| 25                        | M9U11125                                    | M9U21125 | M9U31125 |                                 | M9U11225 | M9U21225 | M9U31225 |                                 |  |
| 32                        | M9U11132                                    | M9U21132 | M9U31132 |                                 | M9U11232 | M9U21232 | M9U31232 |                                 |  |
| 40                        | M9U11140                                    | M9U21140 | M9U31140 |                                 | M9U11240 | M9U21240 | M9U31240 |                                 |  |
| 50                        | M9U11150                                    | M9U21150 | M9U31150 |                                 | M9U11250 | M9U21250 | M9U31250 |                                 |  |
| 63                        | M9U11163                                    | M9U21163 | M9U31163 |                                 | M9U11263 | M9U21263 | M9U31263 |                                 |  |
| <b>Auxiliaries</b>        | Remote indication and tripping, see page 55 |          |          |                                 |          |          |          |                                 |  |
| <b>Accessories</b>        | See page 68                                 |          |          |                                 |          |          |          |                                 |  |

for DC circuits only (cont.)

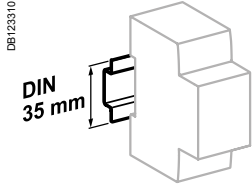

Clip on DIN rail 35 mm (1.38 in)

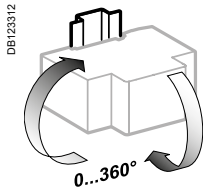

Indifferent position of installation.

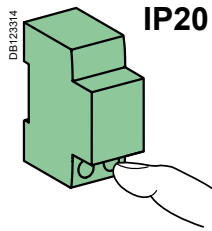

IP20

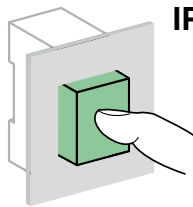

IP40

### Weight (g / oz)

| Circuit breaker |                 |
|-----------------|-----------------|
| Type            | C60H-DC         |
| 1P              | 128 g / 4.51 oz |
| 2P              | 256 g / 9.03 oz |

### Technical data

| Main characteristics                               |                             |  |
|--|-----------------------------|--|
| Insulation voltage (Ui)                            |                             | 500 V DC   |
| Rated service breaking capacity (Ics)              |                             | 75 % of Icu  |
| Pollution degree                                   |                             | 3  |
| Rated impulse withstand voltage (Uimp) under frame |                             | 6 kV   |
| Thermal tripping                                   | Reference temperature       | 25°C / 77°F  |
| Magnetic tripping (li)                             | B curve                     | Between 3 and 7 In   |
|  | C curve                     | Between 7 and 10 In  |
|  | D curve (=K curve)          | Between 10 and 14 In   |
| Additional characteristics                         |                             |  |
| Degree of protection (IEC 60529)                   | Device only                 | IP20   |
| Endurance (O-C)                                    | Device in modular enclosure | IP40<br>Insulation class II  |
|  | Electrical                  | 3,000 cycles (where L/R=2 ms)<br>6,000 cycles where the circuit is resistive |
|  | Mechanical                  | 20,000 cycles  |
| Utilization category                               |                             | A (no delay in accordance with IEC/EN 60947-2 standards)                     |
| Operating temperature                              |                             | -25°C to 70°C / -13°F to 158°F   |
| Storage temperature                                |                             | -40°C to 85°C / -40°F to 185°F   |
| Tropicalization (IEC 60068-1)                      |                             | Treatment 2<br>(relative humidity 95 % at 55°C / 131°F)                      |
| Dissipated power                                   |                             | See page 100   |



Failure to match polarity during connection may lead to a fire hazard and/or serious injury.

- The connection polarity must be observed (marked on the front panel).
- Use only with direct current.
- If two poles are used in series for the American network, use at least a 12 inch / 30 cm cable.

### Connection

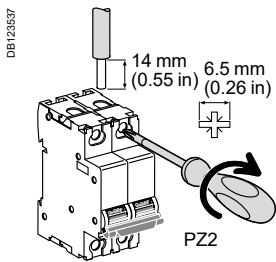

| Rating      | Tightening torque  | Without accessory               |               |
|-------------|--------------------|---------------------------------|---------------|
|             |                    | Copper cables (*)               |               |
|             |                    | Rigid, flexible or with ferrule |               |
|             |                    |                                 |               |
|             |                    | IEC 60947-2                     | UL 486A-B     |
| 0.5 to 25 A | 2.5 N.m (22 lb.in) | 1 to 25 mm <sup>2</sup>         | AWG #18 to #8 |
| 30 to 63 A  | 3.5 N.m (31 lb.in) | 1 to 35 mm <sup>2</sup>         | AWG #18 to #2 |

(\*) See Copper Multi-cable connection chapter for more information, page 109.

### Dimensions (mm / inches)

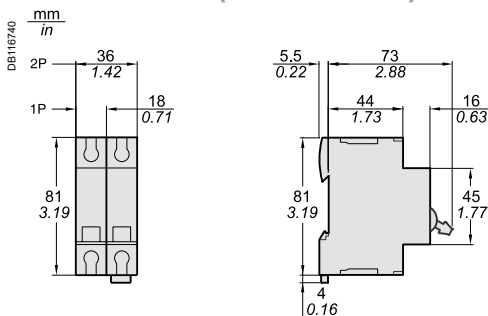

### Railways



| Type  | 1P  | 2P               |
|---|---|------------------|
| Mass of combustible material                    | 39.3 g / 1.39 oz  | 78.6 g / 2.77 oz |
| Type of combustible material                    | PA6 GF20 FR   |                  |
| Fire and smoke requirements (EN 45545-2)        | HL2 R22 / HL2 R23   |                  |
| Resistance to shocks and vibrations (IEC 61373) | <ul style="list-style-type: none"> <li>Category 1</li> <li>Class B</li> </ul> |                  |

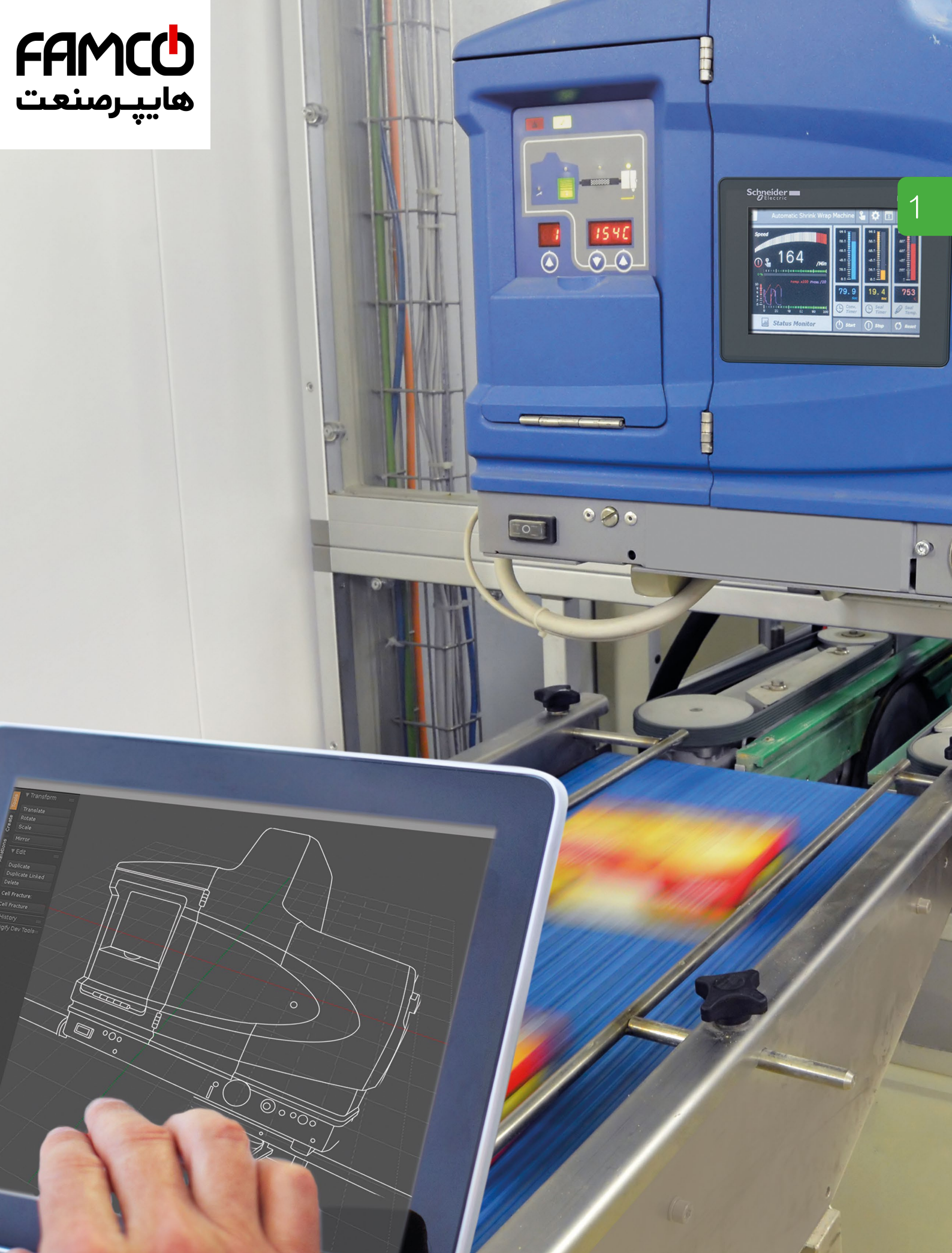

1





C60N 1P



C60N 3P



C60N 2P



C60N 4P

### IEC/EN 60947-2

As per the above standards:

- C60N circuit breakers are circuit breakers which combine the following functions:
  - circuit protection against short-circuit currents,
  - circuit protection against overload currents,
  - breaking and industrial disconnection as per standards IEC/EN 60947-2.
- A green strip on the toggle indicates full opening of all the poles allowing downstream maintenance operation.

- Increased product service life thanks:
  - overvoltage resistance,
  - high performance limitation,
  - to fast closing independent of the speed of actuation of the toggle.
- Upstream or downstream connection.



- Compatible with PowerTag Energy (for 2P, only 200... 240 V AC)

### Positive contact indication

- Suitability for isolation in accordance with the IEC/EN 60947-2 standard.

### Alternating current (AC) 50/60 Hz

Ultimate breaking capacity (Icu) as per IEC/EN 60947-2

| Ph/Ph (2P, 3P, 4P)    | Voltage (Ue) |       |         |       | Service breaking capacity (Ics) |
|-----------------------|--------------|-------|---------|-------|---------------------------------|
|                       | 240 V        | 415 V | -       | 440 V |                                 |
| Ph/N (1P)             | -            | 240 V | 415 V   | -     | 75 % of Icu                     |
| Rating (In) 1 to 63 A | 20 kA        | 10 kA | 3 kA(*) | 6 kA  |                                 |
| i <sub>r</sub>        | 1.2 x 12 In  |       |         |       |                                 |

(\*) Breaking capacity under 1 pole with IT isolated neutral system (case of double fault).

### Direct current (DC)

Breaking capacity (Icu) according to IEC/EN 60947-2

| Between +/-           | Voltage (Ue) |         |         |         | Service breaking capacity (Ics) |
|-----------------------|--------------|---------|---------|---------|---------------------------------|
|                       | ≤ 72 V       | ≤ 125 V | ≤ 180 V | ≤ 250 V |                                 |
| Number of poles       | 1P           | 2P      | 3P      | 4P      | 100 % of Icu                    |
| Rating (In) 1 to 63 A | 15 kA        | 20 kA   | 30 kA   | 40 kA   |                                 |





## Catalog numbers

### C60N circuit breaker

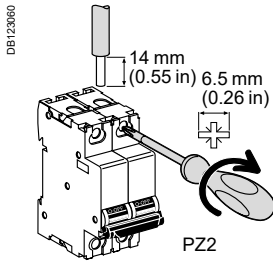
| Type                         | 1P                                    |          |          | 2P       |          |          | 3P       |          |          | 4P       |          |          |
|------------------------------|---------------------------------------|----------|----------|----------|----------|----------|----------|----------|----------|----------|----------|----------|
|                              |                                       |          |          |          |          |          |          |          |          |          |          |          |
| Rating (In)                  | Curve                                 |          |          | Curve    |          |          | Curve    |          |          | Curve    |          |          |
|                              | B                                     | C        | D        | B        | C        | D        | B        | C        | D        | B        | C        | D        |
| 1 A                          | M9F10101                              | M9F11101 | M9F12101 | M9F10201 | M9F11201 | M9F12201 | M9F10301 | M9F11301 | M9F12301 | M9F10401 | M9F11401 | M9F12401 |
| 2 A                          | M9F10102                              | M9F11102 | M9F12102 | M9F10202 | M9F11202 | M9F12202 | M9F10302 | M9F11302 | M9F12302 | M9F10402 | M9F11402 | M9F12402 |
| 3 A                          | M9F10103                              | M9F11103 | M9F12103 | M9F10203 | M9F11203 | M9F12203 | M9F10303 | M9F11303 | M9F12303 | M9F10403 | M9F11403 | M9F12403 |
| 4 A                          | M9F10104                              | M9F11104 | M9F12104 | M9F10204 | M9F11204 | M9F12204 | M9F10304 | M9F11304 | M9F12304 | M9F10404 | M9F11404 | M9F12404 |
| 6 A                          | M9F10106                              | M9F11106 | M9F12106 | M9F10206 | M9F11206 | M9F12206 | M9F10306 | M9F11306 | M9F12306 | M9F10406 | M9F11406 | M9F12406 |
| 10 A                         | M9F10110                              | M9F11110 | M9F12110 | M9F10210 | M9F11210 | M9F12210 | M9F10310 | M9F11310 | M9F12310 | M9F10410 | M9F11410 | M9F12410 |
| 13 A                         | M9F10113                              | M9F11113 | M9F12113 | M9F10213 | M9F11213 | M9F12213 | M9F10313 | M9F11313 | M9F12313 | M9F10413 | M9F11413 | M9F12413 |
| 16 A                         | M9F10116                              | M9F11116 | M9F12116 | M9F10216 | M9F11216 | M9F12216 | M9F10316 | M9F11316 | M9F12316 | M9F10416 | M9F11416 | M9F12416 |
| 20 A                         | M9F10120                              | M9F11120 | M9F12120 | M9F10220 | M9F11220 | M9F12220 | M9F10320 | M9F11320 | M9F12320 | M9F10420 | M9F11420 | M9F12420 |
| 25 A                         | M9F10125                              | M9F11125 | M9F12125 | M9F10225 | M9F11225 | M9F12225 | M9F10325 | M9F11325 | M9F12325 | M9F10425 | M9F11425 | M9F12425 |
| 32 A                         | M9F10132                              | M9F11132 | M9F12132 | M9F10232 | M9F11232 | M9F12232 | M9F10332 | M9F11332 | M9F12332 | M9F10432 | M9F11432 | M9F12432 |
| 40 A                         | M9F10140                              | M9F11140 | M9F12140 | M9F10240 | M9F11240 | M9F12240 | M9F10340 | M9F11340 | M9F12340 | M9F10440 | M9F11440 | M9F12440 |
| 50 A                         | M9F10150                              | M9F11150 | -        | M9F10250 | M9F11250 | -        | M9F10350 | M9F11350 | -        | M9F10450 | M9F11450 | -        |
| 63 A                         | M9F10163                              | M9F11163 | -        | M9F10263 | M9F11263 | -        | M9F10363 | M9F11363 | -        | M9F10463 | M9F11463 | -        |
| Width in 9-mm (0.35 in) mod. | 2                                     |          |          | 4        |          |          | 6        |          |          | 8        |          |          |
| Vigi C60                     | See page 44                           |          |          |          |          |          |          |          |          |          |          |          |
| Auxiliaries                  | See page 55                           |          |          |          |          |          |          |          |          |          |          |          |
| Accessories                  | See page 55                           |          |          |          |          |          |          |          |          |          |          |          |
| PowerTag                     | See PowerLogic catalog: PLSED309005EN |          |          |          |          |          |          |          |          |          |          |          |

### Connection



| Rating     | Tightening torque  | Without accessory   |   |
|------------|--------------------|---|---|
|            |                    | Copper cables (*)   |   |
|            |                    | Rigid, flexible or with ferrule   |   |
| 1 to 25 A  | 2.5 N.m / 22 lb.in |  |  |
| 32 to 63 A | 3.5 N.m / 31 lb.in |  |  |

(\*) See Copper Multi-cable connection chapter for more information, page 109.

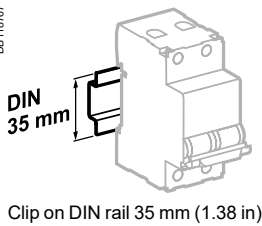

Clip on DIN rail 35 mm (1.38 in)

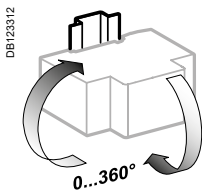

Indifferent position of installation.

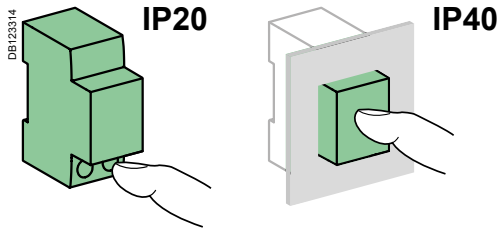

### Technical data

| According to IEC/EN 60947-2            |                             |                        |  |
|--|-----------------------------|------------------------|--|
| Insulation voltage (Ui)                |                             | 500 V AC               |  |
| Pollution degree                       |                             | 3                      |  |
| Rated impulse withstand voltage (Uimp) |                             | 6 kV                   |  |
| Thermal tripping                       | Reference temperature       | 50°C / 122°F           |  |
| Magnetic tripping (Ii)                 | B curve                     | in alternative current | 4 In ± 20 %  |
|  |                             | in direct current      | 5.7 In (± 20 %)                                      |
| C curve                                | in alternative current      |                        | 8.5 In ± 20 %  |
|  | in direct current           |                        | 12 In (± 20 %)                                       |
| D curve                                | in alternative current      |                        | 12 In ± 20 %   |
|  | in direct current           |                        | 17 In (± 20 %)                                       |
| According to current frequency         |                             |                        | 50/60 Hz   |
| Utilization category                   |                             |                        | A  |
| Additional characteristics             |                             |                        |  |
| Degree of protection (IEC 60529)       | Device only                 |                        | IP20   |
|  | Device in modular enclosure |                        | IP40   |
| Endurance (O-C)                        | Electrical                  |                        | 10,000 cycles  |
|  | Mechanical                  |                        | 20,000 cycles  |
| Service temperature                    |                             |                        | -30°C to +70°C / -22°F to 158°F                      |
| Storage temperature                    |                             |                        | -40°C to +80°C / -40°F to 176°F                      |
| Tropicalization (IEC 60068-1)          |                             |                        | Treatment 2 (relative humidity 95 % at 55°C / 131°F) |
| Dissipated power                       |                             |                        | See page 100   |

### Weight (g / oz)

| Circuit breaker |                  |
|-----------------|------------------|
| Type            | C60N             |
| 1P              | 120 g / 4.23 oz  |
| 2P              | 240 g / 8.46 oz  |
| 3P              | 360 g / 12.70 oz |
| 4P              | 480 g / 16.93 oz |

### Dimensions (mm / inches)

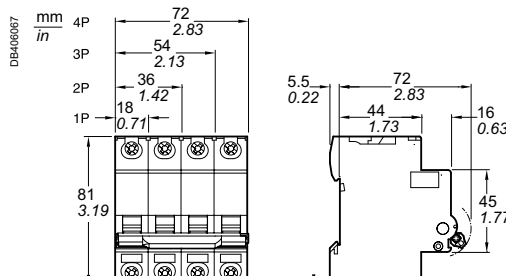



C60H 1P



C60H 3P



C60H 2P



C60H 4P

### IEC/EN 60947-2

As per the above standards:

- C60H circuit breakers are circuit breakers which combine the following functions:
  - circuit protection against short-circuit currents,
  - circuit protection against overload currents,
  - breaking and industrial disconnection as per standards IEC/EN 60947-2.
- A green strip on the toggle indicates full opening of all the poles allowing downstream maintenance operation.

- Increased product service life thanks:
  - overvoltage resistance,
  - high performance limitation,
  - to fast closing independent of the speed of actuation of the toggle.
- Upstream or downstream connection.



- Compatible with PowerTag Energy

### Positive contact indication

- Suitability for isolation in accordance with the IEC/EN 60947-2 standard.

| Alternating current (AC) 50/60 Hz                      |              |       |         |       |                                 |
|--|--------------|-------|---------|-------|---------------------------------|
| Ultimate breaking capacity (Icu) as per IEC/EN 60947-2 |              |       |         |       | Service breaking capacity (Ics) |
| Ph/Ph (2P, 3P, 4P)                                     | Voltage (Ue) |       |         |       |                                 |
|  | 240 V        | 415 V | -       | 440 V | 50 % of Icu                     |
| Ph/N (1P)  | -            | 240 V | 415 V   | -     |                                 |
| Rating (In) 1 to 40 A                                  | 30 kA        | 15 kA | 3 kA(*) | 10 kA |                                 |
| $i_{tr}$   | 1.2 x 12 In  |       |         |       |                                 |

(\*) Breaking capacity under 1 pole with IT isolated neutral system (case of double fault).

| Direct current (DC)                                 |              |         |         |         |                                 |
|---|--------------|---------|---------|---------|---------------------------------|
| Breaking capacity (Icu) according to IEC/EN 60947-2 |              |         |         |         | Service breaking capacity (Ics) |
| Between +/-   | Voltage (Ue) |         |         |         |                                 |
|   | ≤ 72 V       | ≤ 125 V | ≤ 180 V | ≤ 250 V | 100 % of Icu                    |
| Number of poles                                     | 1P           | 2P      | 3P      | 4P      |                                 |
| Rating (In) 1 to 40 A                               | 20 kA        | 25 kA   | 40 kA   | 50 kA   |                                 |





## Catalog numbers

| C60N circuit breaker         |                                       |          |          |          |          |          |          |          |          |          |          |          |
|------------------------------|---------------------------------------|----------|----------|----------|----------|----------|----------|----------|----------|----------|----------|----------|
| Type                         | 1P                                    |          |          | 2P       |          |          | 3P       |          |          | 4P       |          |          |
| E45002                       |                                       |          |          |          |          |          |          |          |          |          |          |          |
| Rating (In)                  | Curve                                 |          |          | Curve    |          |          | Curve    |          |          | Curve    |          |          |
|                              | B                                     | C        | D        | B        | C        | D        | B        | C        | D        | B        | C        | D        |
| 1 A                          | M9F13101                              | M9F14101 | M9F15101 | M9F13201 | M9F14201 | M9F15201 | M9F13301 | M9F14301 | M9F15301 | M9F13401 | M9F14401 | M9F15401 |
| 2 A                          | M9F13102                              | M9F14102 | M9F15102 | M9F13202 | M9F14202 | M9F15202 | M9F13302 | M9F14302 | M9F15302 | M9F13402 | M9F14402 | M9F15402 |
| 3 A                          | M9F13103                              | M9F14103 | M9F15103 | M9F13203 | M9F14203 | M9F15203 | M9F13303 | M9F14303 | M9F15303 | M9F13403 | M9F14403 | M9F15403 |
| 4 A                          | M9F13104                              | M9F14104 | M9F15104 | M9F13204 | M9F14204 | M9F15204 | M9F13304 | M9F14304 | M9F15304 | M9F13404 | M9F14404 | M9F15404 |
| 6 A                          | M9F13106                              | M9F14106 | M9F15106 | M9F13206 | M9F14206 | M9F15206 | M9F13306 | M9F14306 | M9F15306 | M9F13406 | M9F14406 | M9F15406 |
| 10 A                         | M9F13110                              | M9F14110 | M9F15110 | M9F13210 | M9F14210 | M9F15210 | M9F13310 | M9F14310 | M9F15310 | M9F13410 | M9F14410 | M9F15410 |
| 13 A                         | M9F13113                              | M9F14113 | M9F15113 | M9F13213 | M9F14213 | M9F15213 | M9F13313 | M9F14313 | M9F15313 | M9F13413 | M9F14413 | M9F15413 |
| 16 A                         | M9F13116                              | M9F14116 | M9F15116 | M9F13216 | M9F14216 | M9F15216 | M9F13316 | M9F14316 | M9F15316 | M9F13416 | M9F14416 | M9F15416 |
| 20 A                         | M9F13120                              | M9F14120 | M9F15120 | M9F13220 | M9F14220 | M9F15220 | M9F13320 | M9F14320 | M9F15320 | M9F13420 | M9F14420 | M9F15420 |
| 25 A                         | M9F13125                              | M9F14125 | M9F15125 | M9F13225 | M9F14225 | M9F15225 | M9F13325 | M9F14325 | M9F15325 | M9F13425 | M9F14425 | M9F15425 |
| 32 A                         | M9F13132                              | M9F14132 | M9F15132 | M9F13232 | M9F14232 | M9F15232 | M9F13332 | M9F14332 | M9F15332 | M9F13432 | M9F14432 | M9F15432 |
| 40 A                         | M9F13140                              | M9F14140 | M9F15140 | M9F13240 | M9F14240 | M9F15240 | M9F13340 | M9F14340 | M9F15340 | M9F13440 | M9F14440 | M9F15440 |
| Width in 9-mm (0.35 in) mod. | 2                                     |          |          | 4        |          |          | 6        |          |          | 8        |          |          |
| Vigi C60                     | See page 44                           |          |          |          |          |          |          |          |          |          |          |          |
| Auxiliaries                  | See page 55                           |          |          |          |          |          |          |          |          |          |          |          |
| Accessories                  | See page 68                           |          |          |          |          |          |          |          |          |          |          |          |
| PowerTag                     | See PowerLogic catalog: PLSED309005EN |          |          |          |          |          |          |          |          |          |          |          |

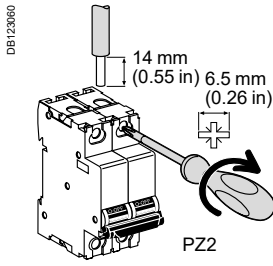

### Connection



| Rating      | Tightening torque  | Without accessory   |   |
|-------------|--------------------|---|---|
|             |                    | Copper cables (*)   |   |
|             |                    | Rigid, flexible or with ferrule   |   |
| 1 to 25 A   | 2.5 N.m / 22 lb.in |  |  |
| 32 and 40 A | 3.5 N.m / 31 lb.in |  |  |

(\*) See Copper Multi-cable connection chapter for more information, page 109.

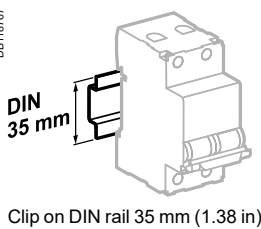

Clip on DIN rail 35 mm (1.38 in)

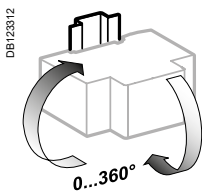

Indifferent position of installation.

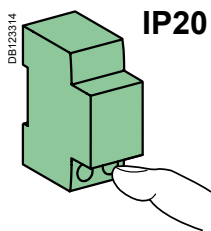

IP20

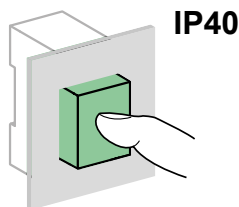

IP40

### Technical data

| According to IEC/EN 60947-2            |                                |                        |  |
|--|--------------------------------|------------------------|--|
| Insulation voltage (Ui)                |                                | 500 V AC               |  |
| Pollution degree                       |                                | 3                      |  |
| Rated impulse withstand voltage (Uimp) |                                | 6 kV                   |  |
| Thermal tripping                       | Reference temperature          | 50°C / 122°F           |  |
| Magnetic tripping (Ii)                 | B curve                        | in alternative current | 4 In ± 20 %  |
|  |                                | in direct current      | 5.7 In (± 20 %)                                      |
| C curve                                | in alternative current         |                        | 8.5 In ± 20 %  |
|  | in direct current              |                        | 12 In (± 20 %)                                       |
| D curve                                | in alternative current         |                        | 12 In ± 20 %   |
|  | in direct current              |                        | 17 In (± 20 %)                                       |
|  | According to current frequency |                        | 50/60 Hz   |
| Utilization category                   |                                |                        | A  |
| Additional characteristics             |                                |                        |  |
| Degree of protection (IEC 60529)       | Device only                    |                        | IP20   |
|  | Device in modular enclosure    |                        | IP40   |
| Endurance (O-C)                        | Electrical                     |                        | 10,000 cycles  |
|  | Mechanical                     |                        | 20,000 cycles  |
| Service temperature                    |                                |                        | -30°C to +70°C / -22°F to 158°F                      |
| Storage temperature                    |                                |                        | -40°C to +80°C / -40°F to 176°F                      |
| Tropicalization (IEC 60068-1)          |                                |                        | Treatment 2 (relative humidity 95 % at 55°C / 131°F) |
| Dissipated power                       |                                |                        | See page 100   |

### Weight (g / oz)

| Circuit breaker |                  |
|-----------------|------------------|
| Type            | C60H             |
| 1P              | 120 g / 4.23 oz  |
| 2P              | 240 g / 8.46 oz  |
| 3P              | 360 g / 12.70 oz |
| 4P              | 480 g / 16.93 oz |

### Dimensions (mm / inches)

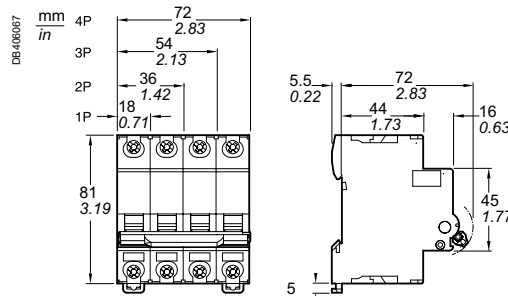

### IEC



C60L 1P



C60L 3P



C60L 2P



C60L 4P

### IEC/EN 60947-2

As per the above standards:

- C60L circuit breakers are circuit breakers which combine the following functions:
  - circuit protection against short-circuit currents,
  - circuit protection against overload currents,
  - breaking and industrial disconnection as per standards IEC/EN 60947-2.
  - A green strip on the toggle indicates full opening of all the poles allowing downstream maintenance operation.
- Increased product service life thanks:
  - overvoltage resistance,
  - high performance limitation,
  - to fast closing independent of the speed of actuation of the toggle.
  - Upstream or downstream connection.
- Compatible with PowerTag Energy

### Positive contact indication

- Suitability for isolation in accordance with the IEC/EN 60947-2 standard.

| Alternating current (AC) 50/60 Hz                      |              |       |          |       |                                 |
|--|--------------|-------|----------|-------|---------------------------------|
| Ultimate breaking capacity (Icu) as per IEC/EN 60947-2 |              |       |          |       | Service breaking capacity (Ics) |
| Ph/Ph (2P, 3P, 4P)                                     | Voltage (Ue) |       |          |       |                                 |
|  | 240 V        | 415 V | -        | 440 V | 50 % of Icu                     |
| Ph/N (1P)  | -            | 240 V | 415 V    | -     |                                 |
| Rating (In) 1 to 25 A                                  | 50 kA        | 25 kA | 3 kA (*) | 20 kA |                                 |
| $i_{tr}$   | 1.2 x 8.5 In |       |          |       |                                 |

(\*) Breaking capacity under 1 pole with IT isolated neutral system (case of double fault).

| Direct current (DC)                                 |              |         |         |         |                                 |
|---|--------------|---------|---------|---------|---------------------------------|
| Breaking capacity (Icu) according to IEC/EN 60947-2 |              |         |         |         | Service breaking capacity (Ics) |
| Between +/-   | Voltage (Ue) |         |         |         |                                 |
|   | ≤ 72 V       | ≤ 125 V | ≤ 180 V | ≤ 250 V | 100 % of Icu                    |
| Number of poles                                     | 1P           | 2P      | 3P      | 4P      |                                 |
| Rating (In) 1 to 25 A                               | 25 kA        | 30 kA   | 50 kA   | 60 kA   |                                 |

### Catalog numbers

| C60L circuit breaker            |  |            |            |            |  |
|---------------------------------|--|------------|------------|------------|--|
| Type                            | 1P                                     | 2P         | 3P         | 4P         |  |
|                                 | E45092<br>                             | E45094<br> | E45095<br> | E45097<br> |  |
| Rating (In)                     | Curve C                                | Curve C    | Curve C    | Curve C    |  |
| 1 A                             | M9F17101                               | M9F17201   | M9F17301   | M9F17401   |  |
| 2 A                             | M9F17102                               | M9F17202   | M9F17302   | M9F17402   |  |
| 3 A                             | M9F17103                               | M9F17203   | M9F17303   | M9F17403   |  |
| 4 A                             | M9F17104                               | M9F17204   | M9F17304   | M9F17404   |  |
| 6 A                             | M9F17106                               | M9F17206   | M9F17306   | M9F17406   |  |
| 10 A                            | M9F17110                               | M9F17210   | M9F17310   | M9F17410   |  |
| 16 A                            | M9F17116                               | M9F17216   | M9F17316   | M9F17416   |  |
| 20 A                            | M9F17120                               | M9F17220   | M9F17320   | M9F17420   |  |
| 25 A                            | M9F17125                               | M9F17225   | M9F17325   | M9F17425   |  |
| Width in 9-mm (0.35 in) modules | 2                                      | 4          | 6          | 8          |  |
| Vigi C60                        | See page 44                            |            |            |            |  |
| Auxiliaries                     | See page 55                            |            |            |            |  |
| Accessories                     | See page 68                            |            |            |            |  |
| PowerTag energy sensors         | See PowerLogic catalog: PLSLED309005EN |            |            |            |  |

### Connection

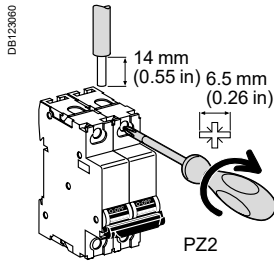

| Rating    | Tightening torque  | Without accessory               |               |
|-----------|--------------------|---------------------------------|---------------|
|           |                    | Copper cables (*)               |               |
|           |                    | Rigid, flexible or with ferrule |               |
| 1 to 25 A | 2.5 N.m / 22 lb.in |                                 |               |
|           |                    | 1 to 25 mm <sup>2</sup>         | AWG #18 to #8 |

(\*) See Copper Multi-cable connection chapter for more information, page 109.

### Technical data

#### According to IEC/EN 60947-2

|  |                        |                |
|--|------------------------|----------------|
| Insulation voltage (Ui)                | 500 V AC               |                |
| Pollution degree                       | 3                      |                |
| Rated impulse withstand voltage (Uimp) | 6 kV                   |                |
| Thermal tripping Reference temperature | 50°C / 122°F           |                |
| Magnetic tripping (Ii) C curve         | in alternative current | 8.5 In ± 20 %  |
|  | in direct current      | 12 In (± 20 %) |
| According to current frequency         | 50/60 Hz               |                |
| Utilization category                   | A                      |                |

#### Additional characteristics

|                                  |  |               |
|----------------------------------|--|---------------|
| Degree of protection (IEC 60529) | Device only  | IP20          |
|                                  | Device in modular enclosure                          | IP40          |
| Endurance (O-C)                  | Electrical   | 10,000 cycles |
|                                  | Mechanical   | 20,000 cycles |
| Service temperature              | -30°C to +70°C / -22°F to 158°F                      |               |
| Storage temperature              | -40°C to +80°C / -40°F to 176°F                      |               |
| Tropicalization (IEC 60068-1)    | Treatment 2 (relative humidity 95 % at 55°C / 131°F) |               |
| Dissipated power                 | See page 100   |               |

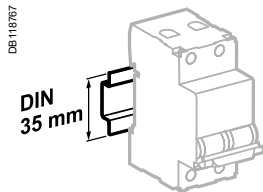

Clip on DIN rail 35 mm (1.38 in)

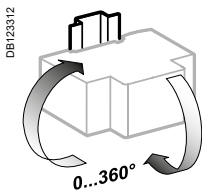

Indifferent position of installation.

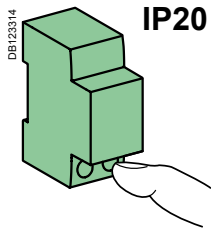

IP20

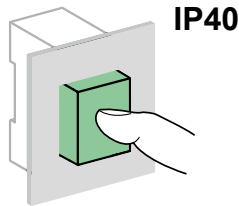

IP40

### Weight (g / oz)

#### Circuit breaker

| Type | C60L             |
|------|------------------|
| 1P   | 120 g / 4.23 oz  |
| 2P   | 240 g / 8.46 oz  |
| 3P   | 360 g / 12.70 oz |
| 4P   | 480 g / 16.93 oz |

### Dimensions (mm / inches)

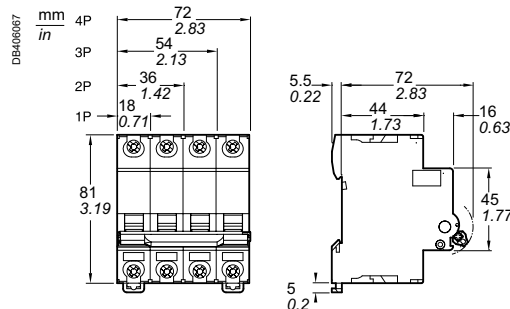



IEC



C60CTRL 1P



C60CTRL 2P

### IEC/EN 60947-2.

As per the above standards:

"C60CTRL circuit breakers for the protection of control circuits" protect and isolate:

- control circuits for industrial equipment with contactor coils, transformers, small motors, etc.
- programmable controllers (PLCs), voltage presence indicators, measuring and monitoring instruments, etc.
- single-phase auxiliary circuits such as solenoid valves, battery chargers, etc.

■ C60CTRL circuit breakers combine the following features:

- protection of circuits against short-circuit and overload currents,
- breaking and isolation capability in the industrial sector to IEC/EN 60947-2.

■ A green strip on the toggle indicates full opening of all the poles allowing downstream maintenance operation.

■ The service life of the products is improved by:

- good overvoltage withstand capacity,
- fast closure, independent of handle operating speed.

■ They can be connected upstream and downstream.

#### Alternating current (AC) 50/60 Hz

| Breaking capacity (Icu) to IEC/EN 60947-2 |              |        | Service breaking capacity (Ics) |
|---|--------------|--------|---------------------------------|
|   | Voltage (Ue) |        |                                 |
| Ph/Ph (2P)                                | 240 V        | 415 V  | 50 % of Icu                     |
| Ph/N (1P)                                 | -            | 240 V  |                                 |
| Rating (In)                               | 1 to 4 A     | 100 kA |                                 |

#### Direct current (DC)

| Breaking capacity (Icu) to IEC/EN 60947-2 |              |       | Service breaking capacity (Ics) |
|---|--------------|-------|---------------------------------|
|   | Voltage (Ue) |       |                                 |
| Between +/-                               | 60 V         | 125 V | 100 % of Icu                    |
| Number of poles                           | 1P           | 2P    |                                 |
| Rating (In)                               | 1 to 4 A     | 25 kA |                                 |

## Catalog numbers

### C60CTRL circuit breakers for the protection of control circuits

| Type                            | 1P          |          | 2P       |          |
|---------------------------------|-------------|----------|----------|----------|
|                                 | E46092      |          | E46094   |          |
|                                 |             |          |          |          |
| Rating (In)                     | C curve     | Z curve  | C curve  | Z curve  |
| 1 A                             | M9C01101    | M9C02301 | M9C01201 | M9C02401 |
| 2 A                             | M9C01102    | M9C02302 | M9C01202 | M9C02402 |
| 3 A                             | M9C01103    | M9C02303 | M9C01203 | M9C02403 |
| 4 A                             | M9C01104    | M9C02304 | M9C01204 | M9C02404 |
| Width in 9 mm (0.35 in) modules | 2           |          | 4        |          |
| Vigi C60                        | See page 44 |          |          |          |
| Auxiliaries                     | See page 55 |          |          |          |
| Accessories                     | See page 68 |          |          |          |

**Connection**

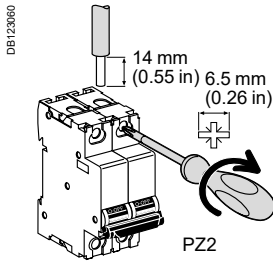

| Rating   | Tightening torque  | Without accessory       |                                 |
|----------|--------------------|-------------------------|---------------------------------|
|          |                    | Copper cables (*)       | Rigid, flexible or with ferrule |
| 1 to 4 A | 2.5 N.m / 22 lb.in | DB122945<br>            | DB122946<br>                    |
|          |                    | 1 to 25 mm <sup>2</sup> | AWG #18 to #8                   |

(\*) See Copper Multi-cable connection chapter for more information, page 109.

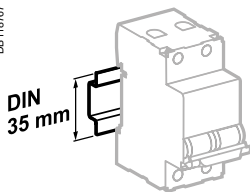

Clip on DIN rail 35 mm.

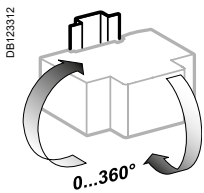

Indifferent position of installation.

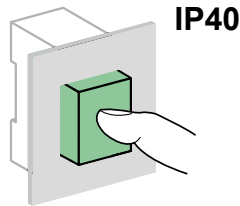
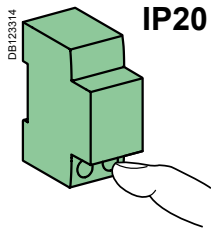

**Technical data**

**According to IEC/EN 60947-2**

|  |  |
|--|--|
| Insulation voltage (Ui)                | 500 V AC                                     |
| Pollution degree                       | 1  |
| Rated impulse withstand voltage (Uimp) | 6 kV   |
| Thermal tripping                       | Reference temperature 50°C / 122°F           |
| Magnetic tripping (Ii)                 | C curve in alternative current 8.5 In ± 20 % |
|  | in direct current 12 In (± 20 %)             |
| Z curve                                | in alternative current 3 In ± 20 %           |
|  | in direct current 4.2 In (± 20 %)            |
| According to current frequency         | 50/60 Hz                                     |
| Utilization category                   | A  |

**Additional characteristics**

|                                  |  |               |
|----------------------------------|--|---------------|
| Degree of protection (IEC 60529) | Device only  | IP20          |
|                                  | Device in modular enclosure                          | IP40          |
| Endurance (O-C)                  | Electrical   | 10,000 cycles |
|                                  | Mechanical   | 20,000 cycles |
| Operating temperature            | -30°C to +70°C / -22°F to 158°F                      |               |
| Storage temperature              | -40°C to +80°C / -40°F to 176°F                      |               |
| Tropicalization (IEC 60068-1)    | Treatment 2 (relative humidity 95 % at 55°C / 131°F) |               |
| Dissipated power                 | See page 100   |               |

**Weight (g / oz)**

**Circuit breakers**

| Type | C60CTRL         |
|------|-----------------|
| 1P   | 120 g / 4.23 oz |
| 2P   | 240 g / 8.46 oz |

**Dimensions (mm / inches)**

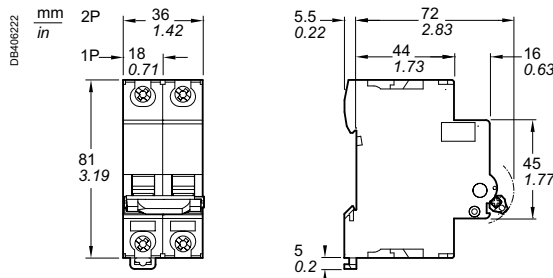

IEC



### IEC/EN 60947-2

As per the above standards:

- N40N circuit breakers are circuit breakers which combine the following functions:
  - circuit protection against short-circuit currents,
  - circuit protection against overload currents,
  - breaking and industrial disconnection as per standards IEC/EN 60947-2.
- A green strip on the toggle indicates full opening of all the poles allowing downstream maintenance operation.

- Increased product service life thanks:
  - overvoltage resistance,
  - high performance limitation,
  - to fast closing independent of the speed of actuation of the toggle.
- Upstream or downstream connection.

- Compatible with PowerTag Energy

### Positive contact indication

- Suitability for isolation in accordance with the IEC/EN 60947-2 standard.

### Alternating current (AC) 50/60 Hz

Ultimate breaking capacity (Icu) as per IEC/EN 60947-2

| Voltage (Ue)          |              | Service breaking capacity (Ics) |
|-----------------------|--------------|---------------------------------|
| Ph/Ph (3P+N)          | 415 V        |                                 |
| Ph/N (1P+N)           | 240 V        |                                 |
| Rating (In) 1 to 40 A | 10 kA        | 75 % of Icu                     |
| $i_{tr}$              | 1.2 x 8.5 In |                                 |

### Catalog numbers

#### N40N circuit breakers

| Type                         | 10 kA                               |          |
|------------------------------|-------------------------------------|----------|
|                              | 1P+N                                | 3P+N     |
| DB123889                     |                                     | DB123861 |
| Rating (In)                  | C curve                             | C curve  |
| 1 A                          | M9P22601                            | -        |
| 2 A                          | M9P22602                            | -        |
| 3 A                          | M9P22603                            | -        |
| 4 A                          | M9P22604                            | -        |
| 6 A                          | M9P22606                            | M9P22706 |
| 10 A                         | M9P22610                            | M9P22710 |
| 16 A                         | M9P22616                            | M9P22716 |
| 20 A                         | M9P22620                            | M9P22720 |
| 25 A                         | M9P22625                            | M9P22725 |
| 32 A                         | M9P22632                            | M9P22732 |
| 40 A                         | M9P22640                            | M9P22740 |
| Width in 9-mm (0.35 in) mod. | 2                                   | 6        |
| Vigi                         | See page 46                         |          |
| Auxiliaries                  | See page 55                         |          |
| Accessories                  | See page 68                         |          |
| PowerTag energy sensors      | See PowerLogic catalog: PLS309005EN |          |



### Connection

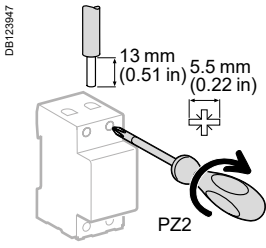

| Rating    | Tightening torque | Copper cables (*)       |               |                          |               |
|-----------|-------------------|-------------------------|---------------|--------------------------|---------------|
|           |                   | Rigid                   |               | Flexible or with ferrule |               |
| 1 to 40 A | 2 N.m / 18 lb.in  | 1 to 16 mm <sup>2</sup> | AWG #18 to #6 | 1 to 10 mm <sup>2</sup>  | AWG #18 to #8 |

(\*) See Copper Multi-cable connection chapter for more information, page 109.

■ Connection by comb busbar or cables (as per EN 50027).

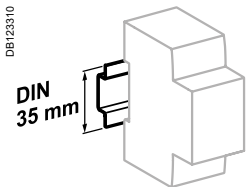

Clips on to 35 mm (1.38 in) DIN rail

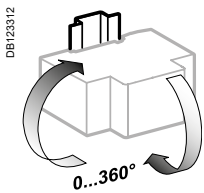

Indifferent position of installation.

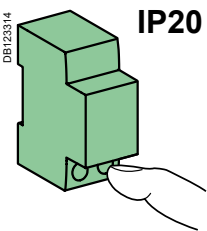

IP20

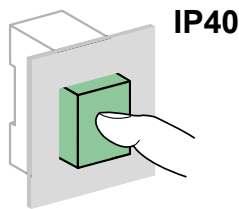

IP40

### Technical data

#### Main characteristics

##### According to IEC/EN 60947-2

|  |                       |                 |
|--|-----------------------|-----------------|
| Insulation voltage (Ui)                | Phase-to-phase        | 240...415 V AC  |
| Thermal tripping                       | Reference temperature | 50°C / 122°F    |
| Magnetic tripping                      | C curve               | 8.5 In (± 20 %) |
| Rated impulse withstand voltage (Uimp) |                       | 4 kV            |
| Pollution degree                       |                       | 3               |

#### Additional characteristics

|                                  |                             |  |               |
|----------------------------------|-----------------------------|--|---------------|
| Degree of protection (IEC 60529) | Device only                 | IP20   |               |
|                                  | Device in modular enclosure | IP40   |               |
| Endurance (O-C)                  | Electrical                  | ≤ 20 A   | 20,000 cycles |
|                                  |                             | ≥ 25 A   | 10,000 cycles |
|                                  | Mechanical                  | 20,000 cycles  |               |
| Operating temperature            |                             | -25°C to +70°C / -13°F to 158°F                      |               |
| Storage temperature              |                             | -40°C to +70°C / -40°F to 158°F                      |               |
| Tropicalization (IEC 60068-1)    |                             | Treatment 2 (relative humidity 95 % at 55°C / 131°F) |               |
| Dissipated power                 |                             | See page 100   |               |

### Dimensions (mm / inches)

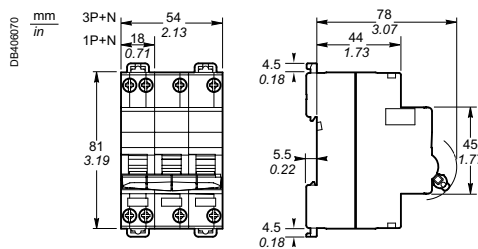

### Weight (g / oz)

#### Circuit breakers

| Type | N40N             |
|------|------------------|
| 1P+N | 115 g / 4.06 oz  |
| 3P+N | 322 g / 11.35 oz |



**IEC/EN 61008-1  
UL 1053**

As per the above standards:

UL 1053 residual current circuit breakers already protected upstream by a circuit breaker device are used for:

- control and disconnection of electric circuits
- protection of people against electric shock by direct and indirect contacts
- protection of installations against insulation faults
- enhanced continuity of supply, during a series of close lightning strokes, IT earthing system, equipment including interference suppression filters, variable speed controllers, frequency converters, electronic ballasts for lighting
- enhanced earth leakage protection: in presence of harmonics or high frequency rejections.

They comply with RCD standards UL 1053 and IEC/EN 61008.

A-SI type GFPs are ideal for operation in environments with a humid atmosphere and/or polluted by aggressive agents: swimming pools, marinas, agri-food industries, water treatment stations, industrial sites, etc.

**Catalog numbers**

| GFP UL 1053 A-SI type |                    |                     |                    |                              |  |                                 |          |
|-----------------------|--------------------|---------------------|--------------------|------------------------------|--|---------------------------------|----------|
| A-SI type             | Rating (A)         | Sensitivity (mA)    |                    | Cat. no.                     |  | Width in mod. of 9 mm (0.35 in) |          |
|                       |                    | UL 1053             | IEC/EN 61008       | 120 or 240 V<br>230 or 240 V | 240 V<br>480Y/277 V<br>230/400 or<br>240/415 V |                                 |          |
| Auxiliaries           |                    | Without auxiliaries |                    |                              |  |                                 |          |
| <b>2P</b>             |                    |                     |                    |                              |  |                                 |          |
|                       | 25                 | 26                  | 30                 | M9R81225                     | M9R41225                                       | 4                               |          |
|                       |                    | 86                  | 100                | M9R12225                     | -  |                                 |          |
|                       |                    | 260                 | 300                | M9R84225                     | M9R44225                                       |                                 |          |
|                       | 40                 | 26                  | 30                 | M9R81240                     | M9R41240                                       |                                 |          |
|                       |                    | 260                 | 300                | M9R84240                     | -  |                                 |          |
|                       |                    | 63                  | 26                 | 30                           | M9R81263                                       |                                 | -        |
| <b>4P</b>             |                    |                     |                    |                              |  |                                 |          |
|                       | 25                 | 26                  | 30                 | -                            | M9R81425                                       | 8                               |          |
|                       |                    | 86                  | 100                | -                            | M9R12425                                       |                                 |          |
|                       |                    | 260                 | 300                | -                            | M9R84425                                       |                                 |          |
|                       | 40                 | 26                  | 30                 | -                            | M9R81440                                       |                                 |          |
|                       |                    | 260                 | 300                | -                            | M9R84440                                       |                                 |          |
|                       |                    | 63                  | 26                 | 30                           | -  |                                 | M9R81463 |
|                       | 100                | 86                  | 100                | -                            | M9R12463                                       |                                 |          |
|                       |                    | 260                 | 300                | -                            | M9R12491                                       |                                 |          |
|                       |                    | 260                 | 300                | -                            | M9R84491                                       |                                 |          |
|                       | <b>Accessories</b> |                     | <b>See page 48</b> |                              |  |                                 |          |
|                       | Voltage rating     | 2P                  | 230 - 240 V        |                              |  |                                 |          |
|                       | (Ue)               | 4P                  | 400 - 415 V        |                              |  |                                 |          |
| Operating frequency   | 50/60 Hz           |                     |                    |                              |  |                                 |          |

**UL 486A connections for copper cables, document #E216919**

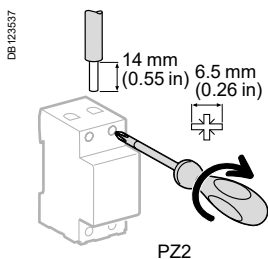

| Rating      | Tightening torque  | Without accessory               |               |
|-------------|--------------------|---------------------------------|---------------|
|             |                    | Copper cables (*)               |               |
|             |                    | Rigid, flexible or with ferrule |               |
| 25 to 100 A | 3.5 N.m / 31 lb.in |                                 |               |
|             |                    | IEC/EN 61008-1                  | UL 486A-B     |
|             |                    | 1 to 35 mm <sup>2</sup>         | AWG #18 to #2 |

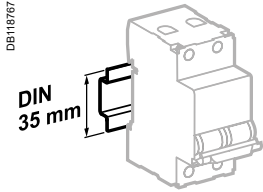

Clip on DIN rail 35 mm (1.38 in)

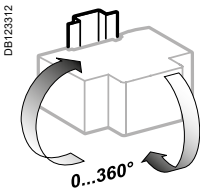

Indifferent position of installation.

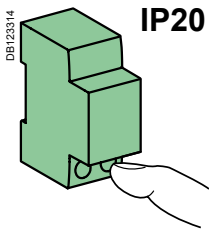

IP20

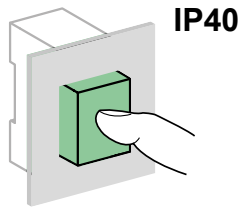

IP40

## Technical data

### GFP UL 1053 A-SI type

#### Technical data

|  |  |
|--|--|
| Insulation voltage (Ui)  | 440 V  |
| Pollution degree   | 3  |
| Making and breaking capacity:<br>rated residual current (I $\Delta$ m) | 1 500 A  |
| Rated impulse withstand voltage<br>(Uimp)                              | 6 kV   |
| Utilisation category   | AC 23A   |
| Level of immunity  | In current wave 8/20 $\mu$ s: 3 kA<br>In dampened recurrent current wave<br>0.5 $\mu$ s/100 kHz: 200 A |
| Short-circuit current withstand (I $\Delta$ c = Inc)                   | 10 kA with 100 A gG upstream fuse  |
| Test button minimum<br>operating voltage                               | 2P 113 V AC<br>4P 189 V AC   |
| Phase-to-phase test circuit  | To avoid external bridging on use on<br>three-phase network without neutral                            |
| Locking possible in "tripped"<br>position                              | By padlocking facility (not supplied)  |
| Release with fixed sensitivity<br>for all ratings                      | Instantaneous release:<br>UL 1053 : $\pm$ 15 %<br>IEC/EN 61008 : +0 %, -50 %                           |
| Behaviour in case of<br>voltage drop                                   | Residual current protection down to 0 V<br>according to IEC/EN 61008-1 § 3.3.4                         |
| Earth fault indication   | On front face by red mechanical indicator  |
| Number of cycles (O-C)   | 20,000 cycles  |
| Degree of protection<br>(IEC 60529)                                    | Device only IP20<br>Device in modular<br>enclosure IP40<br>Insulation class II                         |
| Operating temperature  | -25°C to +60°C / -13°F to 140°F  |
| Storage temperature  | -40°C to +70°C / -40°F to 158°F  |
| Tropicalization (IEC 60068-1)  | Treatment 2<br>(relative humidity 95 % at 55°C / 131°F)  |
| Dissipated power   | See page 100   |

## Weight (g / oz)

### GFP UL 1053 A-SI type

| Type | GFP              |
|------|------------------|
| 2P   | 220 g / 7.76 oz  |
| 4P   | 450 g / 15.87 oz |

## Dimensions (mm / inches)

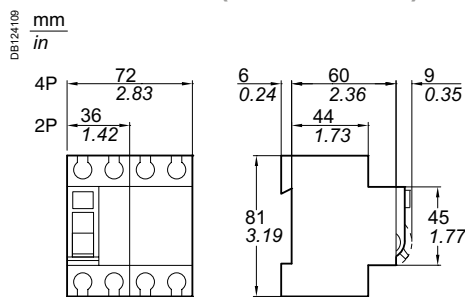



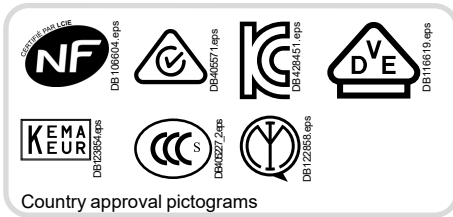

IEC/EN 61008-2-1, IEC/EN 62423  
IEC 61543 ,VDE 0664

As per the above standards:

- The Acti9 iID B-SI type residual current circuit breakers provide:
  - protection of persons against electric shock by direct contact (30 mA),
  - protection of persons against electric shock by indirect contact ( $\geq 300$  mA),
  - protection of installations against the risk of fire (300 mA or 500 mA).

**B-SI type**

The Acti9 iID B-SI type residual current circuit breakers provide:

- protection in the event of a continuous earth fault current on networks generated by:
  - controllers and variable speed drives,
  - battery chargers and inverters, such as used in photovoltaic application,
  - backed-up power supplies.

■ They include protection against earth fault currents:

- sinusoidal AC residual currents (AC type),
- pulsed DC residual currents (A type),
- multi frequency residual current (F type).

■ The use of Acti9 iID B-SI type residual current circuit breaker can be made mandatory, according to standards applicable in country.

■ For applications using 3-poles drives, such as:

- crane,
- lift,
- HVAC,
- pumping system.

**B type is needed.**

For more information, see Earth Fault Protection guide (CA908066E).

■ The Acti9 iID B-SI type works optimally with the variable speed drives manufactured by Schneider Electric, even with a long cable length between motor and variable speed drive (up to 50 m).

■ SI technology is embedded in Acti9 iID B-SI type residual current circuit breaker, providing increased immunity from electrical interference and polluted environments.

■ The Acti9 iID B-SI type is compatible with Schneider Electric AC and A types wired in parallel or in series in the installation, following coordination tables (refer to Earth Fault Protection guide CA908066E).

■ Compatible with PowerTag Energy

**Catalog numbers**

| Acti9 iID B-SI type residual current circuit breakers |             |          |          |          |          |                              |
|---|-------------|----------|----------|----------|----------|------------------------------|
| Type  | B-SI        |          |          |          |          | Width in 9 mm (0.35 in) mod. |
| 2P  | Sensitivity | 30 mA    | 300 mA   | 300 mA   | 500 mA   |                              |
|   | Rating 25 A | A9Z61225 | A9Z64225 | -        | -        | 8                            |
|   | 40 A        | A9Z61240 | A9Z64240 | -        | -        |                              |
|   | 63 A        | A9Z61263 | A9Z64263 | -        | -        |                              |
| Voltage rating (Ue)                                   |             | 230 V    |          |          |          |                              |
| Operating frequency                                   |             | 50 Hz    |          |          |          |                              |
| 4P  | Sensitivity | 30 mA    | 300 mA   | 300 mA   | 500 mA   |                              |
|   | Rating 25 A | A9Z61425 | A9Z64425 | -        | -        | 8                            |
|   | 40 A        | A9Z61440 | A9Z64440 | A9Z65440 | A9Z66440 |                              |
|   | 63 A        | A9Z61463 | A9Z64463 | A9Z65463 | A9Z66463 |                              |
|   | 80 A        | A9Z61480 | A9Z64480 | A9Z65480 | A9Z66480 |                              |
| Voltage rating (Ue)                                   |             | 400 V    |          |          |          |                              |
| Operating frequency                                   |             | 50 Hz    |          |          |          |                              |

(cont.)

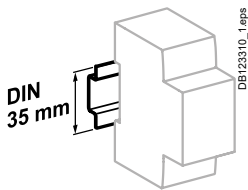

Clip on DIN rail 35 mm (1.38 in)

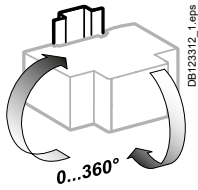

Indifferent position of installation.

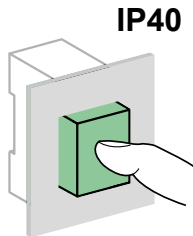
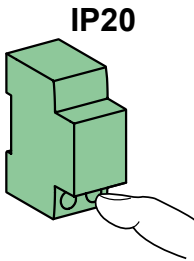

### Technical data

#### Electrical characteristics

|  |      |       |
|--|------|-------|
| Insulation voltage (Ui)                | 2P   | 250 V |
|  | 4P   | 500 V |
| Pollution degree                       | 3    |       |
| Rated impulse withstand voltage (Uimp) | 6 kV |       |

#### According to IEC/EN 61008-2-1

|  |                                       |          |
|--|---------------------------------------|----------|
| Making and breaking capacity (Im/IΔm)              | 1500 A                                |          |
| Surge current withstand (8/20 μs) without tripping | No selective <input type="checkbox"/> | 3 kA     |
|  | Selective <input type="checkbox"/>    | 5 kA     |
| Conditional rated short-circuit current (Inc/IΔc)  | With 100 A gG fuse                    | 10,000 A |

#### Additional characteristics

|  |   |  |
|--|---|--|
| Degree of protection (IEC 60529)               | Device only                                   | IP20   |
|  | Device in modular enclosure                   | IP40<br>Insulation class II                    |
| Endurance (O-C)                                | Electrical                                    | ≤ 63 A: 15,000 cycles<br>> 63 A: 10,000 cycles |
|  | Mechanical                                    | 20,000 cycles                                  |
| Range of test button operating voltage         | 30 mA   | 2P: 180...270 V AC<br>4P: 300...450 V AC       |
|  | 300, 500 mA                                   | 2P: 140...330 V AC<br>4P: 220...450 V AC       |
|  |   |  |
|  | Impulse withstand according to IEC 60068-2-27 | 15 g   |
| Vibration withstand according to IEC 60068-2-6 | 3 g   |  |
| Electromagnetic compatibility                  | According to IEC 61543                        |  |
| Operating temperature                          | -25°C to +60°C / -13°F to +140°F              |  |
| Storage temperature                            | -40°C to +85°C / -40°F to +185°F              |  |
| Dissipated power                               | See page 100                                  |  |

### Dielectric test

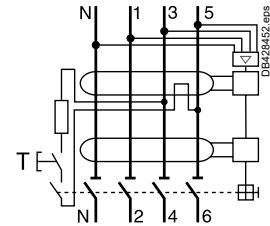
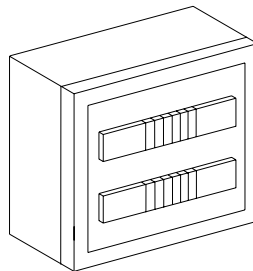

**⚠ To perform any dielectric test, disconnect terminals:**

- 4P: 1, 3, 5 and 2, 4, 6
- 2P: 1 and 2

Except for insulation resistance test at 500 V DC between L1, L2, L3 & N all connected, and the earth circuit.

### Weight (g / oz)

| Residual current circuit breakers |                  |
|-----------------------------------|------------------|
| Type                              | iID              |
| 2P                                | 350 g / 12.35 oz |
| 4P                                | 415 g / 14.64 oz |

### Dimensions (mm / inches)

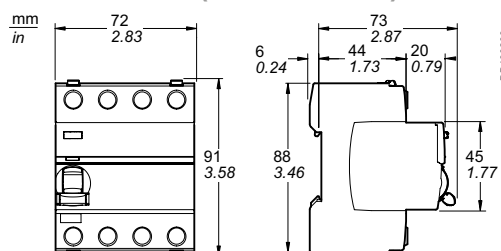

(cont.)

**Connection**

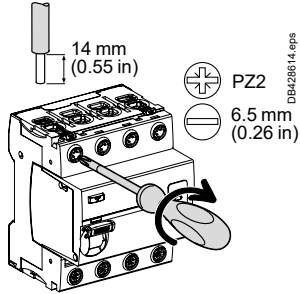

| Rating | Without accessory                       |   |   |   | With accessories               |                                       |                                 |                                 |
|--------|---|---|---|---|--------------------------------|---------------------------------------|---------------------------------|---------------------------------|
|        | Back                                    |   | Front                                   |   | 50 mm <sup>2</sup> AI terminal | Screw-on connection for ring terminal | Multi-cables terminal           |                                 |
|        | Rigid                                   | Flexible or with ferrule                | Rigid                                   | Flexible or with ferrule                |                                |                                       | Rigid cables                    | Flexible cables                 |
| All    | 1 to 25 mm <sup>2</sup> / AWG #18 to #4 | 1 to 16 mm <sup>2</sup> / AWG #18 to #6 | 1 to 35 mm <sup>2</sup> / AWG #18 to #2 | 1 to 25 mm <sup>2</sup> / AWG #18 to #4 | 50 mm <sup>2</sup> / AWG #1    | Ø 5 mm / 0.2 in                       | 3 x 16 mm <sup>2</sup> / AWG #6 | 3 x 10 mm <sup>2</sup> / AWG #8 |

Accessories: see page 73

- Insulated terminals IP20**
  - DB428584.eps
  - DB428595.eps
- Double terminals**
  - For top or bottom connections:
    - by cable,
    - by comb busbar
- Double clip locking** allowing tool-free removal, front panel side, with the comb busbar in position
- Test button**
  - DB428598.eps
- Large circuit labelling area**
- Voltage presence LED**
  - For an optimal use of the LED, Acti9 iID must be power supplied by top connections
  - Led indication (powered by top connections):
    - On: powered and ready
    - Off: not powered
- DB428597.eps**
- VISI-TRIP window**
  - Fault tripping is indicated by a red mechanical indicator on the front face
- DB428240.eps**
- VISI-SAFE window**
  - Positive contact indication**
    - A green strip on the toggle indicates full opening of all the poles
    - Padlocking possible





# 25 A Residual Current Circuit Breakers (AC, A, A-SI, B types)

IEC/EN 61008-1  
IEC/EN 61008-2-1  
VDE 0664

As per the above standards:

- The RCCB-ID 125 A residual current circuit breakers provide:
  - protection of persons against electric shock by direct contact (30 mA),
  - protection of persons against electric shock by indirect contact ( $\geq 100$  mA),
  - protection of installations against the risk of fire (300 mA or 500 mA).

The **A-SI** type provides increased immunity from electrical interference and polluted or corrosive environments.



- Compatible with PowerTag Energy (4P only)

### B type

■ The RCCB-ID B type residual current circuit breakers provide specific protection of three-phase installations and people even in the presence of DC fault currents on the network generated by:

- 3-poles controllers and variable speed drives,
- 3-poles battery chargers and inverters,
- 3-poles backed-up power supplies.

### Instantaneous

It ensures instantaneous tripping (without time delay).

### Selective

It ensures total discrimination with a non-selective RCD placed downstream.

### OFsp auxiliary

■ Electrical indication: by OFsp auxiliary mounted to the left, it has a double changeover switch indicating the "open" or "closed" position of the RCCB-ID 125 A.

### Accessories

- 2P and 4P sealable screw shield.



## Catalog numbers

### RCCB-ID 125 A residual current circuit breakers

| Type                    |             | AC    |        |                                       |        | A     |        |        |        |
|-------------------------|-------------|-------|--------|---------------------------------------|--------|-------|--------|--------|--------|
|                         |             | 30 mA | 100 mA | 300 mA                                | 500 mA | 30 mA | 300 mA | 300 mA | 500 mA |
| 2P<br>                  | Rating      | 125 A |        |                                       |        |       |        |        |        |
|                         | Sensitivity | 30 mA | 100 mA | 300 mA                                | 500 mA | 30 mA | 300 mA | 300 mA | 500 mA |
| 4P<br>                  | Rating      | 125 A |        |                                       |        |       |        |        |        |
|                         | Sensitivity | 30 mA | 100 mA | 300 mA                                | 500 mA | 30 mA | 300 mA | 300 mA | 500 mA |
| Voltage rating (Ue)     |             | 2P    |        | 230 V                                 |        | 4P    |        | 400 V  |        |
| Operating frequency     |             |       |        | 50 Hz                                 |        |       |        |        |        |
| PowerTag energy sensors |             |       |        | See PowerLogic catalog: PLSED309005EN |        |       |        |        |        |

**Catalog numbers**

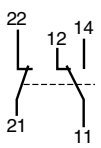

| Auxiliary   |         |                 |       | Width in 9 mm (0.35 in) mod. |
|---|---------|-----------------|-------|------------------------------|
| Type  | Contact | Voltage         |       |                              |
|  | 1 A     | 110 V DC        | 16940 | 1                            |
|   | 6 A     | 230 V AC (AC15) |       |                              |

| Accessory   |                |       |
|---|----------------|-------|
| Type  | Number of pole |       |
| Screw shield (set of 10) for upstream or downstream | 2P             | 16938 |
|   | 4P             | 16939 |

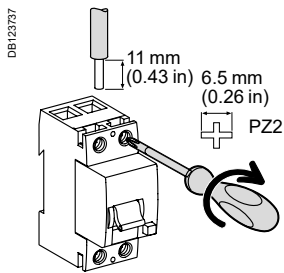

**Connection**

■ By tunnel terminals for:



| Type    | Tightening torque  | Copper cables (*)   |   |
|---------|--------------------|---|---|
|         |                    | Rigid   | Flexible or with ferrule  |
| RCCB-ID | 3 N.m / 26.6 lb.in |  |  |
| OFsp    | 0.8 N.m / 7 lb.in  | 1 to 1.5 mm <sup>2</sup> / AWG #18 to #16   |   |

(\*) See Copper Multi-cable connection chapter for more information, page 109.

|  |        |   |        |        |        |   | Width in 9 mm (0.35 in) modules |
|--|--------|---|--------|--------|--------|---|---------------------------------|
| A-SI  |        | B  |        |        |        |   |                                 |
| 30 mA  | 300 mA | -   | -      | -      | -      | - | 4                               |
| 16972  | -      | -   | -      | -      | -      | - |                                 |
| 30 mA  | 300 mA | 30 mA   | 300 mA | 300 mA | 500 mA |   | 8                               |
| 16920  | 16921  | 16763   | 16764  | 16765  | 16766  |   |                                 |





**Technical data**

**OFsp contact status, depending on the position of the residual current circuit breaker**

| Type          |                             |        |        |        |
|---------------|-----------------------------|--------|--------|--------|
| RCCB-ID 125 A | Closed                      | ■      | -      | -      |
|               | Open                        | -      | ■      | -      |
|               | Tripped on electrical fault | -      | -      | ■      |
| Contact OFsp  | 22/21                       | Open   | Closed | Closed |
|               | 12/11                       | Open   | Closed | Closed |
|               | 14/11                       | Closed | Open   | Open   |

| Electrical characteristics             |       |
|--|-------|
| Insulation voltage (Ui)                | 400 V |
| Pollution degree                       | 3     |
| Rated impulse withstand voltage (Uimp) | 4 kV  |

| According to IEC/EN 61008-1                        |   |   |
|--|---|---|
| Making and breaking capacity (Im/IΔm)              | 1250 A  |   |
| Surge current withstand (8/20 μs) without tripping | AC and A types (not selective ☒)  | 250 A   |
|  | A-SI and B types (not selective ☒)  | 3 kA  |
|  | AC, A, A-SI and B types (selective ☒)   | 3 kA  |
| Conditional rated short-circuit current (Inc/IΔc)  | With FU 125 A gG fuse   | 10,000 A  |
| Behaviour in case of voltage drop                  |  | Residual current protection down to 0 V according to IEC/EN 61008-1 § 3.3.4 |

| Additional characteristics             |  |                                  |  |
|--|--|----------------------------------|--|
| Degree of protection                   | Device only  | IP20<br>IP40 with screw shield   |  |
|  | Device in modular enclosure  | IP40<br>Insulation class II      |  |
| Endurance (O-C)                        | Electrical   | > 2 000 cycles                   |  |
|  | Mechanical   | > 5 000 cycles                   |  |
| Operating temperature                  |  | -25°C to +40°C / -13°F to +104°F |  |
|  | Storage temperature  | AC, A, A-SI types<br>B type      | -40°C to +85°C / -40°F to +185°F<br>-40°C to +60°C / -40°F to +140°F |
| Range of test button operating voltage | 30 mA  | 2P                               | 160...250 V AC   |
|  |  | 4P                               | 250...440 V AC   |
|  | 100, 300, 500 mA   | 2P                               | 185...250 V AC   |
|  |  | 4P                               | 185...440 V AC   |

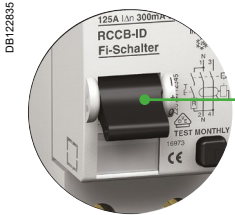

**Indication of the status of the RCCB-ID via the 3-position toggle and front panel indicator**

- Open (toggle in high position and green indicator)
- Closed (toggle in low position and red indicator)
- Tripped on electrical fault (toggle in middle position and green indicator)

**Dielectric test**

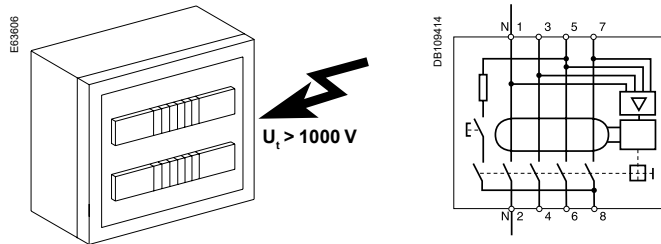

⚠ To perform the dielectric test, disconnect terminals 3, 5, 7 and 4, 6, 8.

**Weight (g / oz)**

| Residual current circuit breakers and auxiliary |                  |                |
|---|------------------|----------------|
| Type  | RCCB-ID 125 A    | OFsp           |
| 2P  | 230 g / 8.11 oz  | 40 g / 1.41 oz |
| 4P AC, A and A-SI types                         | 420 g / 14.82 oz |                |
| B type  | 500 g / 17.64 oz |                |

**Dimensions (mm / inches)**

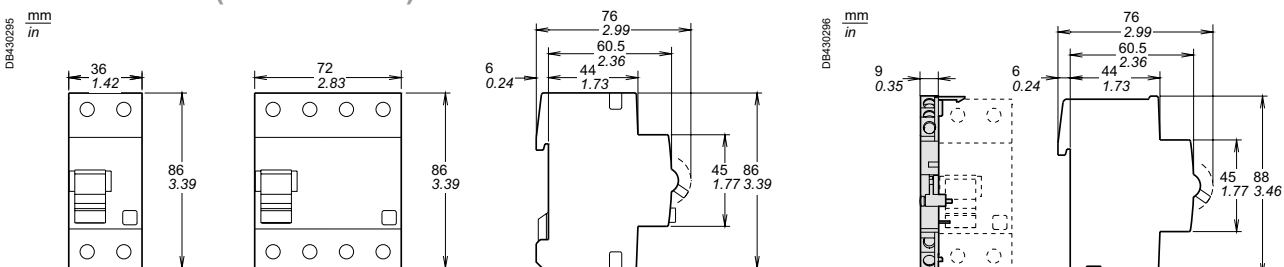



# EC/EN 61008-1 – Residual Current Circuit Breakers

– AC, A-SI types

**IEC**



## IEC/EN 61008-1

As per the above standard:

- RCCB-ID residual current circuit breakers offer the following functions:
  - protection of persons against electric shock by direct contact (30 mA),
  - protection of persons against electric shock by indirect contact (300 mA),
  - protection of installations against fire risks (300 mA).

## A-SI type

The A-SI type offers enhanced immunity to electrical disturbances.

- Compatible with PowerTag Energy:

## Catalog numbers

### RCCB-ID residual current circuit breakers

| Type                    | AC                                    | A-SI        | Width in 9-mm (0.35 in) modules |          |          |   |
|-------------------------|---------------------------------------|-------------|---------------------------------|----------|----------|---|
| <b>2P</b><br><br>Rating | Sensitivity                           | 30 mA       | 300 mA                          | 30 mA    | 300 mA   | 4 |
|                         | 25 A                                  | M9R11225    | -                               | -        | M9R31240 |   |
| 40 A                    | M9R11240                              | M9R14240    | M9R31240                        | M9R35240 |          |   |
| <b>4P</b><br><br>Rating | Sensitivity                           | 30 mA       | 300 mA                          | 30 mA    | 300 mA   | 8 |
|                         | 40 A                                  | M9R11440    | M9R14440                        | M9R31440 | M9R35440 |   |
| 63 A                    | M9R11463                              | M9R14463    | M9R31463                        | M9R35463 |          |   |
| Voltage rating (Ue)     | 2P                                    | 230 - 240 V |                                 |          |          |   |
|                         | 4P                                    | 400 - 415 V |                                 |          |          |   |
| Operating frequency     | 50 Hz                                 |             |                                 |          |          |   |
| Auxiliaries             | See page 55                           |             |                                 |          |          |   |
| Accessories             | See page 68                           |             |                                 |          |          |   |
| PowerTag energy sensors | See PowerLogic catalog: PLSED309005EN |             |                                 |          |          |   |

## Connection

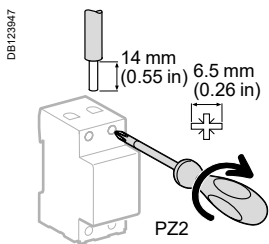

| Rating     | Tightening torque  | Copper cables (*)       |               |                          |               |
|------------|--------------------|-------------------------|---------------|--------------------------|---------------|
|            |                    | Rigid                   |               | Flexible or with ferrule |               |
| 25 to 63 A | 3.5 N.m / 31 lb.in | 1 to 35 mm <sup>2</sup> | AWG #18 to #2 | 1 to 25 mm <sup>2</sup>  | AWG #18 to #4 |

(\*) See Copper Multi-cable connection chapter for more information, page 109.



- IEC/EN 61008-1 – Residual Current Circuit Breakers  
 – AC, A-SI types (cont.)

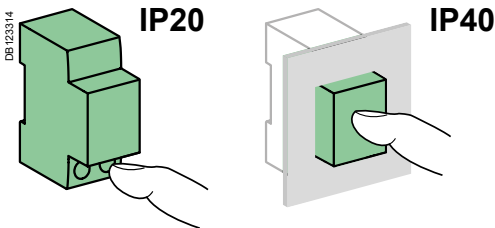
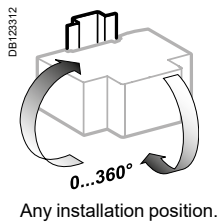
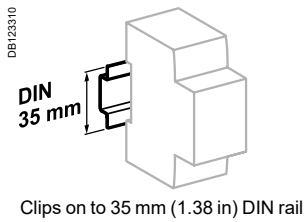

**Technical data**

| Main characteristics  |                             |   |
|---|-----------------------------|---|
| Insulation voltage (U <sub>i</sub> )  |                             | 440 V   |
| Pollution degree  |                             | 3   |
| Rated impulse withstand voltage (U <sub>imp</sub> )                         |                             | 6 kV  |
| According to IEC/EN 61008-1   |                             |   |
| Making and breaking capacity (I <sub>m</sub> /I <sub>Δm</sub> )             |                             | 10 In   |
| Impulse current withstand (8/20 μs) without tripping                        | AC type                     | 250 Å   |
|   | A-SI type                   | 3 kÅ  |
| Rated conditional short-circuit current (I <sub>nc</sub> /I <sub>Δc</sub> ) | With fuse                   | 100 A, 10,000 A   |
| Behaviour in case of voltage drop   |                             | Residual current protection down to 0 V according to IEC/EN 61008-1 § 3.3.4 |
| Additional characteristics  |                             |   |
| Degree of protection (IEC 60529)  | Device only                 | IP20  |
|   | Device in modular enclosure | IP40  |
| Endurance (O-C)   | Electrical                  | 2000 cycles   |
|   | Mechanical                  | 20,000 cycles   |
| Operating temperature   | AC type                     | -5°C to +40°C / 23°F to 104°F   |
|   | A-SI type                   | -25°C to +40°C / -13°F to 104°F   |
| Storage temperature   |                             | -40°C to +60°C / -40°F to 140°F   |
| Tropicalization (IEC 60068-1)   |                             | Treatment 2 (relative humidity 95 % at 55°C / 131°F)                        |
| Dissipated power  |                             | See page 100  |

**Weight (g / oz)**

| Residual current circuit breakers |                  |
|-----------------------------------|------------------|
| Type                              | ID               |
| 2P                                | 230 g / 8.11 oz  |
| 4P                                | 450 g / 15.87 oz |

**Dimensions (mm / inches)**

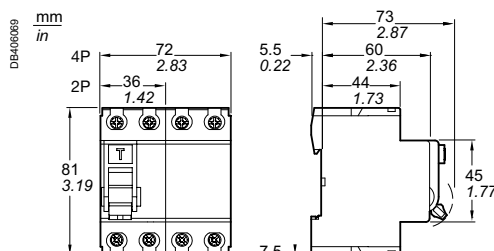

## IEC/EN 61009-1 – Residual Current Devices

– Add-on for C60

**IEC**

### IEC/EN 61009-1

As per the above standard:

- Combined with C60 circuit breaker, the Vigi C60 provide:
  - protection of persons against electric shock by direct contact (30 mA),
  - protection of persons against electric shock by indirect contact (300 mA),
  - protection of installations against the risk of fire (300 mA).
  
- The **A-SI** type provides increased immunity from electrical interference and polluted or corrosive environments.

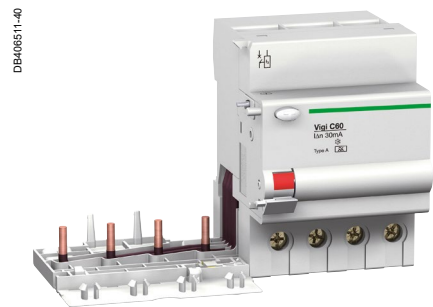
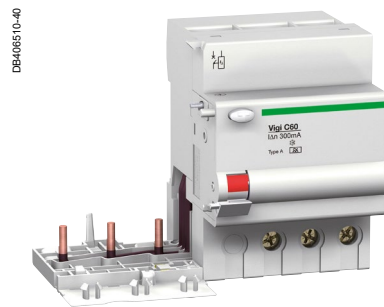
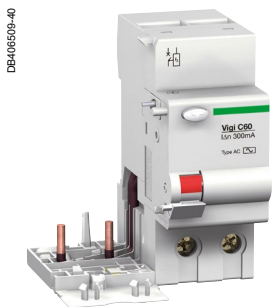

### Catalog numbers

#### Vigi C60 add-on residual current devices

| Type                |             | AC              | A-SI            | Width in 9-mm (0.35 in) modules |
|---------------------|-------------|-----------------|-----------------|---------------------------------|
| <b>2P</b><br>       | Sensitivity | 30 mA           | 300 mA          | 30 mA                           |
|                     | Rating 63 A | <b>M9V11263</b> | <b>M9V14263</b> | <b>M9V31263</b>                 |
| <b>3P</b><br>       | Sensitivity | 30 mA           | 300 mA          | 30 mA                           |
|                     | Rating 63 A | <b>M9V11363</b> | <b>M9V14363</b> | <b>M9V31363</b>                 |
| <b>4P</b><br>       | Sensitivity | 30 mA           | 300 mA          | 30 mA                           |
|                     | Rating 63 A | <b>M9V11463</b> | <b>M9V14463</b> | <b>M9V31463</b>                 |
| Voltage rating (Ue) | 2P          | 230 - 240 V     |                 |                                 |
|                     | 3P-4P       | 400 - 415 V     |                 |                                 |
| Operating frequency |             | 50 Hz           |                 |                                 |

### Connection

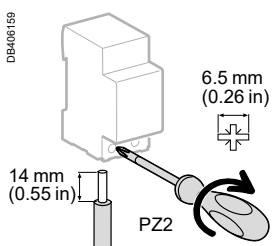

| Tightening torque  | Copper cables (*)           |                             |
|--------------------|-----------------------------|-----------------------------|
|                    | Rigid                       | Flexible or with ferrule    |
| 3.5 N.m / 31 lb.in | <br>1 to 35 mm <sup>2</sup> | <br>1 to 25 mm <sup>2</sup> |
|                    | AWG #18 to #2               | AWG #18 to #4               |

# IEC/EN 61009-1 – Residual Current Devices

## – Add-on for C60 (cont.)

- Reinforced cable pull-out strength: serrated terminals
- Automatic cable guiding in the correct position: terminals with guard

DB-406909-55

Test button



- Every circuit breaker combined with a Vigi module remains compatible with the indication and tripping auxiliaries

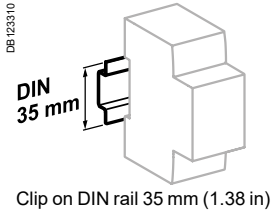

Clip on DIN rail 35 mm (1.38 in)

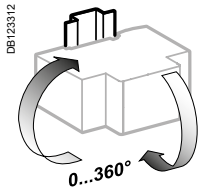

Indifferent position of installation.

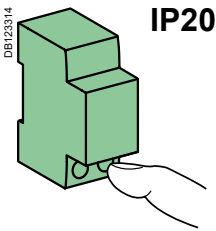

IP20

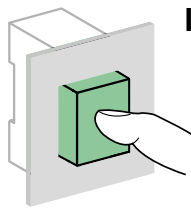

IP40

### Weight (g / oz)

| Type | Vigi modules    |
|------|-----------------|
| 2P   | 150 g / 4.29 oz |
| 3P   | 210 g / 7.40 oz |
| 4P   | 210 g / 7.40 oz |

### Technical data

#### Main characteristics

##### According to IEC/EN 61009-1

|  |                |   |
|--|----------------|---|
| Insulation voltage (U <sub>i</sub> )                 | Phase-to-phase | 500 V AC  |
| Pollution degree                                     |                | 3   |
| Rated impulse withstand voltage (U <sub>imp</sub> )  |                | 4 kV  |
| Impulse current withstand (8/20 μs) without tripping | AC types       | 250 Å   |
|  | A-SI types     | 3 kÅ  |
| Behaviour in case of voltage drop                    |                | Residual current protection down to 0 V according to IEC/EN 61009-1 § 3.3.8 |

#### Additional characteristics

|                                  |                             |  |
|----------------------------------|-----------------------------|--|
| Degree of protection (IEC 60529) | Device only                 | IP20   |
|                                  | Device in modular enclosure | IP40   |
|                                  |                             | Insulation class II                                  |
| Operating temperature            | A-SI types                  | -25°C to +60°C / -13°F to 140°F                      |
|                                  | AC type                     | -5°C to +60°C / 23°F to 140°F                        |
| Storage temperature              |                             | -40°C to +60°C / -40°F to 140°F                      |
| Tropicalization (IEC 60068-1)    |                             | Treatment 2 (relative humidity 95 % at 55°C / 131°F) |
| Dissipated power                 |                             | See page 100   |

#### Railways



| Type  | 2P  | 3P               | 4P               |
|---|---|------------------|------------------|
| Mass of combustible material                    | 44.4 g / 1.55 oz  | 72.6 g / 2.54 oz | 72.6 g / 2.54 oz |
| Type of combustible material                    | PA6 MD25 FR & PA6 MD30 FR   |                  |                  |
| Fire and smoke requirements (EN 45545-2)        | HL2 R22 / HL2 R23   |                  |                  |
| Resistance to shocks and vibrations (IEC 61373) | <ul style="list-style-type: none"> <li>Category 1</li> <li>Class B</li> </ul> |                  |                  |

### Dimensions (mm / inches)

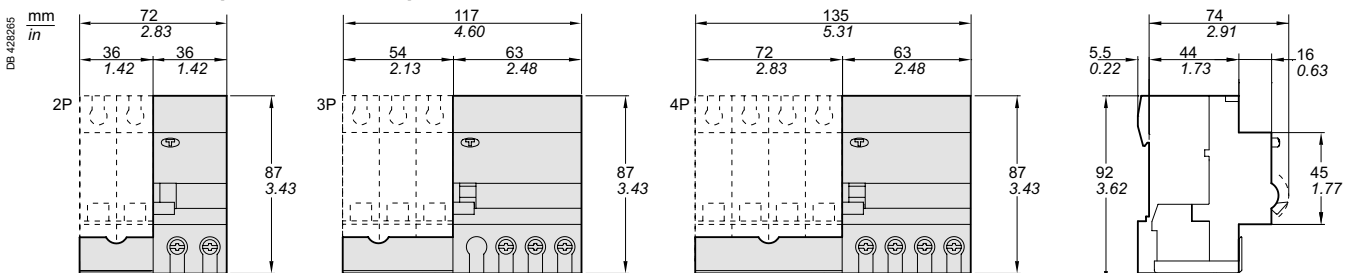



– Add-on for N40

**IEC**

Earth leakage protection devices offer the following functions:

- protection of electrical installations against insulation faults
- protection for people against direct and indirect contact
- protection of the installations against fire risks.

PE11786-40



**IEC/EN 61009-1**

As per the above standard:

The Vigi N40N modules, to be combined with a circuit breaker, incorporate in a single enclosure the residual current relay and the toroid.

- The residual current tripping device is electromechanical and operates without an auxiliary source.
- A homogeneous unit in compliance with the EN 61009-1 and EN 61009-2-1 standards, a residual current device retains all the characteristics of the circuit breaker alone; in particular, the thermal tripping threshold of the circuit breaker is retained in the presence of the earth leakage module.

**Operation**

- When an earth fault occurs, the Vigi module causes automatic opening of the circuit breaker with which it is combined. Fault indication is performed by a red strip on the operating handle for Vigi module resetting.
- Resetting of the earth leakage module is performed, at the user's choice:
  - either by the reset handle of the circuit breaker (in one operation),
  - or independently of the circuit breaker (in 2 operations).

**A-SI type**

The A-SI type offers enhanced immunity to electrical disturbances.

**Catalog numbers**

| Vigi N40 add-on residual current devices |             |          |          |                                 |          |   |
|--|-------------|----------|----------|---------------------------------|----------|---|
| Type                                     | AC          | A-SI     |          | Width in 9-mm (0.35 in) modules |          |   |
| 3P+N                                     | Sensitivity | 30 mA    | 300 mA   | 30 mA                           | 300 mA   |   |
|  | Rating 40 A | M9Y11740 | M9Y14740 | M9Y31740                        | M9Y34740 | 4 |
| Voltage rating (Ue)                      | 400 - 415 V |          |          |                                 |          |   |
| Operating frequency                      | 50 Hz       |          |          |                                 |          |   |

**Connection**

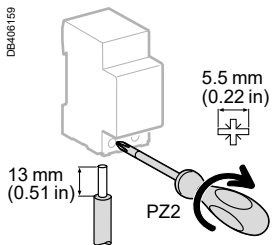

| Tightening torque | Copper cables (*)       |               |                          |               |
|-------------------|-------------------------|---------------|--------------------------|---------------|
|                   | Rigid                   |               | Flexible or with ferrule |               |
| 2 N.m / 18 lb.in  | 1 to 16 mm <sup>2</sup> | AWG #18 to #6 | 1 to 10 mm <sup>2</sup>  | AWG #18 to #8 |

(\*) See Copper Multi-cable connection chapter for more information, page 109.

- Where there is a comb busbar tooth, the connection of cables of cross section 16 mm<sup>2</sup> remains possible.
- Connection:
  - upstream: direct by comb busbar,
  - downstream: by cables.

# IEC/EN 61009-1 – Residual Current Devices

– Add-on for N40 (cont.)

- Reinforced cable pull-out strength: serrated terminals
- Automatic cable guiding in the correct position: terminals with guard

PE11760-45

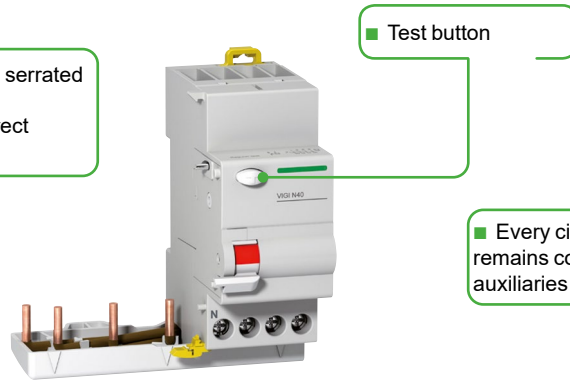

- Every circuit breaker combined with a Vigi module remains compatible with the indication and tripping auxiliaries

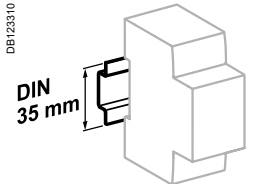

DB12310

Clip on DIN rail 35 mm (1.38 in)

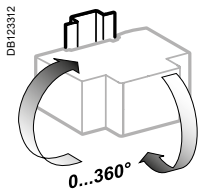

DB12312

Indifferent position of installation

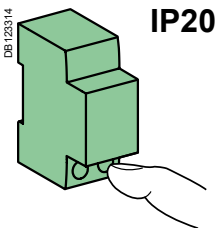

DB12314

IP20

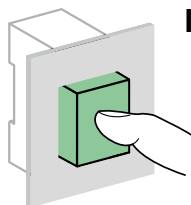

IP40

## Technical data

### Main characteristics

#### According to IEC/EN 61009-1

|  |                |   |
|--|----------------|---|
| Insulation voltage (Ui)  | Phase-to-phase | 440 V AC  |
| Pollution degree   |                | 3   |
| Rated impulse withstand voltage (Uimp)                                   |                | 4 kV  |
| Behaviour in the event of a phase-to-earth fault in TN-S earthing system |                | Residual breaking and making capacity (I $\Delta$ m) identical to the rated breaking capacity (Icn) |
| Behaviour in case of voltage drop  |                | Residual current protection down to 0 V according to IEC/EN 61009-1 § 3.3.8                         |

### Additional characteristics

|                                  |                             |   |
|----------------------------------|-----------------------------|---|
| Degree of protection (IEC 60529) | Device only                 | IP20  |
|                                  | Device in modular enclosure | IP40<br>Insulation class II                             |
| Operating temperature            | AC type                     | -5°C to +60°C / 23°F to 140°F                           |
|                                  | A-SI types                  | -25°C to +60°C / -13°F to 140°F                         |
| Storage temperature              |                             | -40°C to +60°C / -40°F to 140°F                         |
| Tropicalization (IEC 60068-1)    |                             | Treatment 2<br>(relative humidity 95 % at 55°C / 131°F) |
| Dissipated power                 |                             | See page 100  |

## Weight (g / oz)

|      | Vigi modules    |
|------|-----------------|
| Type |                 |
| 3P+N | 210 g / 7.40 oz |

## Dimensions (mm / inches)

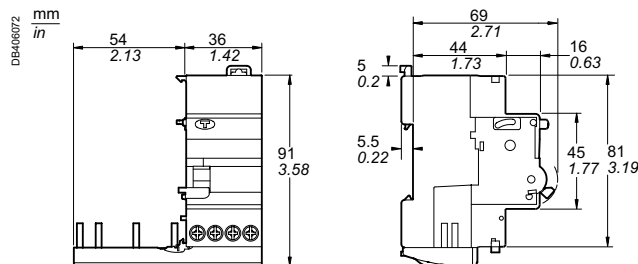

Residual Current circuit Breakers with Overcurrent protection

**IEC**

IEC/EN 61009-1

As per the above standard:

- The N40 Vigi residual current device provides complete protection for final circuits (against overcurrents and insulation faults):
  - protection for people against electric shocks by direct contacts (30 mA),
  - protection for people against electric shocks by indirect contacts (300 mA),
  - protection of installations against risk of fire (300 mA).



**Catalog numbers**

| N40 Vigi 6 kA       |             | AC          |                   | Width in 9-mm (0.35 in) mod. |
|---------------------|-------------|-------------|-------------------|------------------------------|
| Type                |             | 30 mA       | 300 mA            |                              |
| 1P+N C curve        | Sensitivity |             |                   |                              |
|                     | Rating (In) | 6 A         | M9D11606 -        | 4                            |
|                     |             | 10 A        | M9D11610 M9D14610 |                              |
|                     |             | 16 A        | M9D11616 M9D14616 |                              |
|                     |             | 20 A        | M9D11620 M9D14620 |                              |
|                     |             | 25 A        | M9D11625 M9D14625 |                              |
|                     |             | 40 A        | M9D11640 M9D14640 |                              |
| Voltage rating (Ue) |             | 240 V AC    |                   |                              |
| Operating frequency |             | 50 Hz       |                   |                              |
| Auxiliaries         |             | See page 55 |                   |                              |
| Accessories         |             | See page 68 |                   |                              |

**Positive contact indication**

- A green strip on the toggle indicates full opening of all the poles
- Downstream maintenance operations can be carried out in better safety conditions
- Padlocking possible

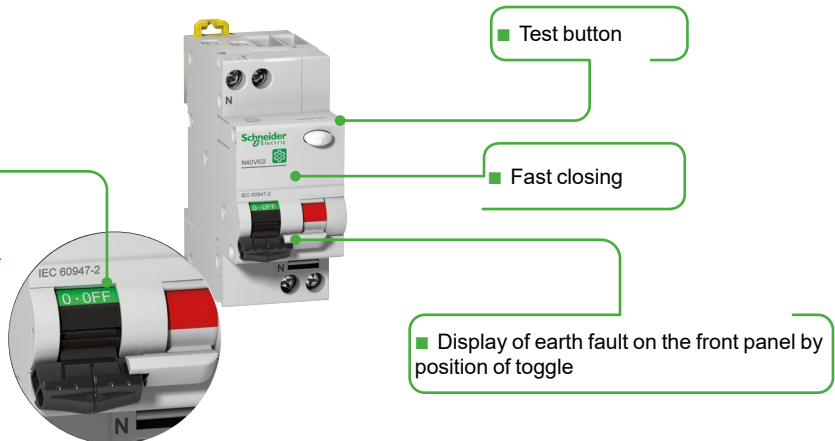

Residual Current circuit Breakers with Overcurrent protection (cont.)

**Connection**

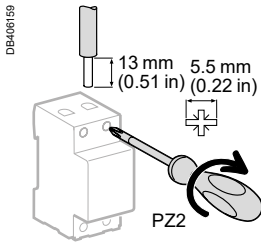

| Tightening torque | Copper cables (*)       |               |                          |               |
|-------------------|-------------------------|---------------|--------------------------|---------------|
|                   | Rigid                   |               | Flexible or with ferrule |               |
| 2 N.m / 18 lb.in  | DB12294E                |               | DB12294E                 |               |
|                   | 1 to 16 mm <sup>2</sup> | AWG #18 to #6 | 1 to 10 mm <sup>2</sup>  | AWG #18 to #8 |

(\*) See Copper Multi-cable connection chapter for more information, page 109.

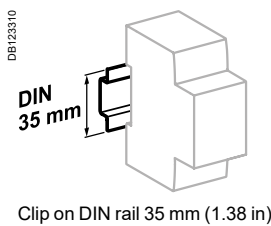

Clip on DIN rail 35 mm (1.38 in)

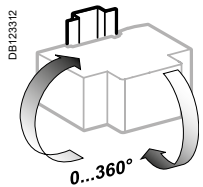

Indifferent position of installation.

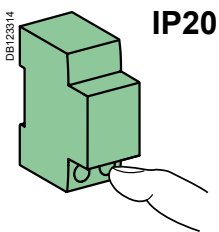

IP20

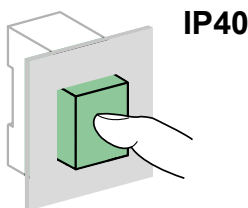

IP40

**Technical data**

**Main characteristics**

|  |                 |
|--|-----------------|
| Insulation voltage (U <sub>i</sub> )                 | 400 V AC        |
| Pollution degree                                     | 3               |
| Rated impulse withstand voltage (U <sub>imp</sub> )  | 4 kV            |
| Setting temperature for ratings                      | 50°C / 122°F    |
| Earth leakage protection with instantaneous tripping | 30, 300 mA      |
| Magnetic tripping C curve                            | 8.5 In (± 20 %) |
| 8/20 µs impulse withstand current                    | 250 Å           |

**According to IEC/EN 61009-1**

|  |   |
|--|---|
| Limitation class   | 3   |
| Rated breaking capacity (I <sub>cn</sub> )                     | 6000 A  |
| Rated residual breaking and making capacity (I <sub>Δm</sub> ) | 6000 A  |
| Behaviour in case of voltage drop                              | Residual current protection down to 0 V according to IEC/EN 61009-1 § 3.3.8 |

**According to IEC/EN 60947-2**

|  |                      |
|--|----------------------|
| Breaking capacity (I <sub>cu</sub> )         | 6 kA                 |
| Service breaking capacity (I <sub>cs</sub> ) | 75 % I <sub>cu</sub> |

**Additional characteristics**

|                                  |                             |  |
|----------------------------------|-----------------------------|--|
| Degree of protection (IEC 60529) | Device only                 | IP20   |
|                                  | Device in modular enclosure | IP40<br>Insulation class II                          |
| Endurance (O-C)                  | Electrical N40 Vigi ≤ 20A   | 20,000 cycles  |
|                                  | N40 Vigi ≥ 25A              | 10,000 cycles  |
|                                  | Mechanical                  | 20,000 cycles  |
| Overvoltage category (IEC 60364) |                             | IV   |
| Operating temperature            |                             | -5°C to +60°C / 23°F to 140°F                        |
| Storage temperature              |                             | -30°C to +70°C / -22°F to 158°F                      |
| Tropicalization (IEC 60068-1)    |                             | Treatment 2 (relative humidity 95 % at 55°C / 131°F) |
| Dissipated power                 |                             | See page 100   |

**Railways**



|   |                           |
|---|---------------------------|
| Type  | 1P+N                      |
| Mass of combustible material                    | 45.8 g / 1.59 oz          |
| Type of combustible material                    | PA6 MD25 FR & PA6 GF20 FR |
| Fire and smoke requirements (EN 45545-2)        | HL2 R22 / HL2 R23         |
| Resistance to shocks and vibrations (IEC 61373) | ■ Category 1<br>■ Class B |

**Weight (g / oz)**

| Residual current device |                 |
|-------------------------|-----------------|
| Type                    | N40 Vigi        |
| 1P+N                    | 125 g / 4.41 oz |

**Dimensions (mm / inches)**

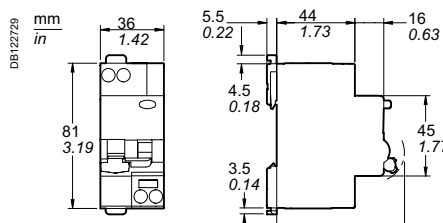





The Type 1 range of surge protective device meets the normative withstand capability of current wave type 8/20  $\mu$ s. PRD1 75r surge protective devices are fitted with dry contacts to send "end-of-life indication" information. PRD1 75r surge protective devices are fitted with easy-to-replace withdrawable cartridges.

### UL 1449 4th Edition Recognized, CSA C22.2 No. 269.4-17, 1<sup>st</sup> Ed

As per the above standard:  
The PRD1 75r surge protective device (SPD) is rated UL and CSA Type 1, and is well suited for use installed within electrical equipment. Rated at 200kA SCCR, without additional upstream protection, it can be installed in a variety of installations including service entrance, branch panels and control panel environments. For serviceability considerations, connecting through a disconnecter is recommended. Replaceable devices are available, should the device reach end of life due to a surge event or sustained over-voltage.

#### Multi9 PRD1 75r Type 1

| Type   | Surge protective devices |                              |                           |                            |           |
|--------|--------------------------|------------------------------|---------------------------|----------------------------|-----------|
|        | Wiring configuration     | Rated network voltage (V AC) | I max (kA) Surge Capacity | In (kA)                    | SCCR (kA) |
| 1P<br> |                          | 120                          | 75                        | 20                         | 200       |
|        |                          | 240                          | 75                        | 20                         | 200       |
|        |                          | 277                          | 75                        | 20                         | 200       |
|        |                          | 347                          | 75                        | 10                         | 200       |
| 2P<br> |                          | 120/240                      | 75                        | 20                         | 200       |
|        |                          | 240/480                      | 75                        | 20                         | 200       |
| 3P<br> |                          | 240                          | 75                        | 20                         | 200       |
|        |                          | 480                          | 75                        | 10                         | 200       |
|        |                          | 120/208                      | 75                        | 20                         | 200       |
|        |                          | 277/480                      | 75                        | 20                         | 200       |
|        |                          | 347/600                      | 75                        | 10                         | 200       |
|        |                          | 400/690                      | 75                        | 10                         | 200       |
| 4P<br> |                          | 120/208                      | 75                        | 20                         | 200       |
|        |                          | 277/480                      | 75                        | 20                         | 200       |
|        |                          | 347/600                      | 75                        | 10 (L1/L2/L3)<br>20 (N-G)  | 200       |
|        |                          | 400/690                      | 75                        | 10 (L1/L2/L3)<br>20 (N-G)  | 200       |
|        |                          | 120/240                      | 75                        | 20                         | 200       |
|        |                          | 240/480                      | 75                        | 20 (L1/L3/N-G)<br>10 (H-L) | 200       |



PRD1 75r (1P)



PRD1 75r (2P)



PRD1 75r (3P)



PRD1 75r (4P)



|  | VPR (V)<br>Voltage Protection<br>Rating                              | MCOV (V)  | SPD wiring<br>(2-, 3-, 4- or<br>5- wire) | Catalog<br>number | Associated cartridge |         |         |               | SPD only                                 |
|--|--|---|--|-------------------|----------------------|---------|---------|---------------|--|
|  |  |   |  |                   | L1                   | L2/H-L  | L3      | G<br>(Ground) | Width in<br>9 mm<br>(0.35 in)<br>modules |
|  | 600 (L-N)  | 175 (L-N)   | 2  | <b>M9L11120</b>   | M9LC175              | -       | -       | -             | 2  |
|  | 900 (L-N)  | 275 (L-N)   | 2  | <b>M9L21240</b>   | M9LC275              | -       | -       | -             | 2  |
|  | 1000 (L-N)   | 320 (L-N)   | 2  | <b>M9L31277</b>   | M9LC320              | -       | -       | -             | 2  |
|  | 1500 (L-N)   | 420 (L-N)   | 2  | <b>M9L41347</b>   | M9LC420              | -       | -       | -             | 2  |
|  | 600 (L-N)<br>1200 (L-L)  | 175 (L-N)<br>350 (L-L)  | 3  | <b>M9L12240</b>   | M9LC175              | M9LC175 | -       | -             | 4  |
|  | 900 (L-N)<br>1800 (L-L)  | 275 (L-N)<br>550 (L-L)  | 3  | <b>M9L22480</b>   | M9LC275              | M9LC275 | -       | -             | 4  |
|  | 900 (L-G)<br>1800 (L-L)  | 275 (L-G)<br>550 (L-L)  | 4  | <b>M9L23240</b>   | M9LC275              | M9LC275 | M9LC275 | -             | 6  |
|  | 1500 (L-G)<br>3000 (L-L)   | 550 (L-G)<br>1100 (L-L)                                       | 4  | <b>M9L53480</b>   | M9LC550              | M9LC550 | M9LC550 | -             | 6  |
|  | 600 (L-N)<br>1200 (L-L)  | 175 (L-N)<br>350 (L-L)  | 4  | <b>M9L13208</b>   | M9LC175              | M9LC175 | M9LC175 | -             | 6  |
|  | 1000 (L-N)<br>2000 (L-L)   | 320 (L-N)<br>640 (L-L)  | 4  | <b>M9L33480</b>   | M9LC320              | M9LC320 | M9LC320 | -             | 6  |
|  | 1500 (L-N)<br>2500 (L-L)   | 420 (L-N)<br>840 (L-L)  | 4  | <b>M9L43600</b>   | M9LC420              | M9LC420 | M9LC420 | -             | 6  |
|  | 1500 (L-N)<br>3000 (L-L)   | 550 (L-N)<br>1100 (L-L)                                       | 4  | <b>M9L53690</b>   | M9LC550              | M9LC550 | M9LC550 | -             | 6  |
|  | 600 (L-N)<br>1200 (L-G)<br>1200 (L-L)<br>600 (N-G)                   | 175 (L-N)<br>175 (L-G)<br>350 (L-L)<br>175 (N-G)              | 5  | <b>M9L17208</b>   | M9LC175              | M9LC175 | M9LC175 | M9LC175       | 8  |
|  | 1000 (L-N)<br>1500 (L-G)<br>2000 (L-L)<br>600 (N-G)                  | 320 (L-N)<br>495 (L-G)<br>640 (L-L)<br>175 (N-G)              | 5  | <b>M9L37480</b>   | M9LC320              | M9LC320 | M9LC320 | M9LC175       | 8  |
|  | 1500 (L-N)<br>2000 (L-G)<br>2500 (L-L)<br>800 (N-G)                  | 420 (L-N)<br>695 (L-G)<br>840 (L-L)<br>275 (N-G)              | 5  | <b>M9L47600</b>   | M9LC420              | M9LC420 | M9LC420 | M9LC275       | 8  |
|  | 1500 (L-N)<br>2500 (L-G)<br>3000 (L-L)<br>1000 (N-G)                 | 550 (L-N)<br>870 (L-G)<br>1100 (L-L)<br>320 (N-G)             | 5  | <b>M9L57690</b>   | M9LC550              | M9LC550 | M9LC550 | M9LC320       | 8  |
|  | 1200 (L-L/L-G)<br>600 (L-N/N-G)<br>1500 (H-L/H-G)<br>800 (H-N)       | 350 (L-L/L-G)<br>175 (L-N/N-G)<br>450 (H-L/H-G)<br>275 (H-N)  | 5  | <b>M9L17240</b>   | M9LC175              | M9LC275 | M9LC175 | M9LC175       | 8  |
|  | 1500 (L-L/L-G)<br>800 (L-N)<br>600 (N-G)<br>2500 (H-L)<br>2000 (H-G) | 550 (L-L)<br>450 (L-G)<br>275 (L-N)<br>175 (N-G)<br>225 (H-L) | 5  | <b>M9L27480</b>   | M9LC275              | M9LC550 | M9LC275 | M9LC175       | 8  |



M9LC275

| Spare cartridge                    |                                 |         |           |  |          |                   |
|------------------------------------|---------------------------------|---------|-----------|--|----------|-------------------|
| Un (V)<br>Rated voltage<br>network | I max (kA)<br>Surge<br>Capacity | In (kA) | SCCR (kA) | VPR (V)<br>Voltage<br>Protection<br>Rating | MCOV (V) | Catalog<br>number |
| 120                                | 75                              | 20      | 200       | 600  | 175      | M9LC175           |
| 240                                | 75                              | 20      | 200       | 900  | 275      | M9LC275           |
| 277                                | 75                              | 20      | 200       | 1000                                       | 320      | M9LC320           |
| 347                                | 75                              | 10      | 200       | 1500                                       | 420      | M9LC420           |
| 400                                | 75                              | 10      | 200       | 1500                                       | 550      | M9LC550           |

### Technical data

|  |                                 | PRD1 75r Type 1   |
|--|---------------------------------|---|
| Operating frequency                        |                                 | 50/60 Hz  |
| Response time                              |                                 | < 25 ns   |
| Short circuit withstand (I <sub>sc</sub> ) |                                 | 200 kA  |
| Ground residual current (I <sub>G</sub> )  | I <sub>G</sub> (Neutral-Ground) | < 1 mA  |
| Surge protective device technology         |                                 | MOV   |
| End-of-life indication                     | Green                           | Correct operation   |
|  | Red                             | At end of life  |
|  | Remote notification             | 250 V AC / 1 A<br>125 V AC / 3 A  |
| Operating temperature                      |                                 | -25°C to +60°C  |
| Storage temperature                        |                                 | -40°C to +85°C  |
| Relative humidity                          |                                 | 5 % to 90 %   |
| Operating altitude                         |                                 | 2000 m  |
| Degree of protection                       | IP                              | NEMA 1 built-in   |
|  | Impacts                         | IK05  |
| Pollution degree                           |                                 | 3   |
| Standards                                  |                                 | UL 1449: 4th Edition Recognized<br>CSA C22.2 No. 269.4-17, 1 <sup>st</sup> Ed |

### Connection



| Wire stripping length |                    | Tightening torque        |                            | Tunnel type terminals                                       |   |  |   |
|-----------------------|--------------------|--------------------------|----------------------------|---|---|--|---|
| L/N/<br>Ground        | Dry contacts       | L/N/<br>Ground           | Dry contacts               | Rigid cable   | Flexible cable<br>or with ferrule                           | Dry contacts   |   |
|                       |                    |                          |                            |   |   | Rigid cable  | Flexible cable  |
| 10 mm<br>(0.4 in.)    | 6 mm<br>(0.24 in.) | 3 N.m<br>(26.5 Lbf. in.) | 0.27 N.m<br>(2.4 Lbf. in.) | DB122846.eps<br>6 to 35 mm <sup>2</sup><br>(AWG 10...AWG 2) | DB122846.eps<br>6 to 25 mm <sup>2</sup><br>(AWG 10...AWG 4) | DB122846.eps<br>Max. 1.5 mm <sup>2</sup><br>(AWG 16) | DB123007.eps<br>0.05 to 2.5 mm <sup>2</sup><br>(AWG 30...AWG14) |

### Weight (g)

| Surge protective device |          |
|-------------------------|----------|
| Type                    | PRD1 75r |
| 1P                      | 154      |
| 2P                      | 340      |
| 3P                      | 522      |
| 4P                      | 703      |
| Cartridge               | 82       |

### Dimensions

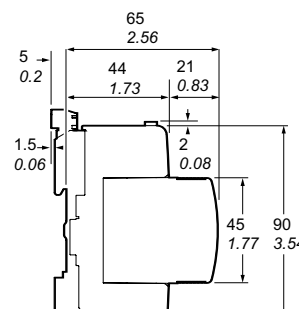
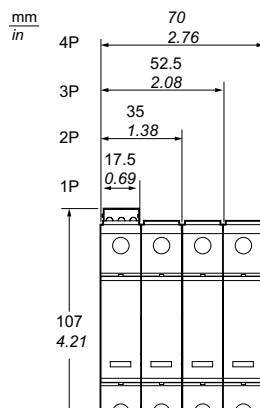









### Compliance with electrical auxiliaries standards

- For UL 489 Branch circuit protection File #E215117.
- For CSA C22.2 No. 5 Branch circuit protection File #179014.
- For UL 1077 Supplementary Protection File #E90509.
- For CSA C22.2 No. 235 Supplementary Protection File #179014.
- For IEC 60947-1 and IEC 60947-5-1 circuit breakers.
- CE Marked.

■ The electrical auxiliaries provide the remote tripping or position (open/closed/tripped) indication functions of these devices in the event of an electrical fault.

■ They clip on (no tool required) to the left-hand side of the associated device.

■ The SD+OF auxiliary is a two-in-one product: a mechanical selector switch is used to select one of two contacts: SD or OF.

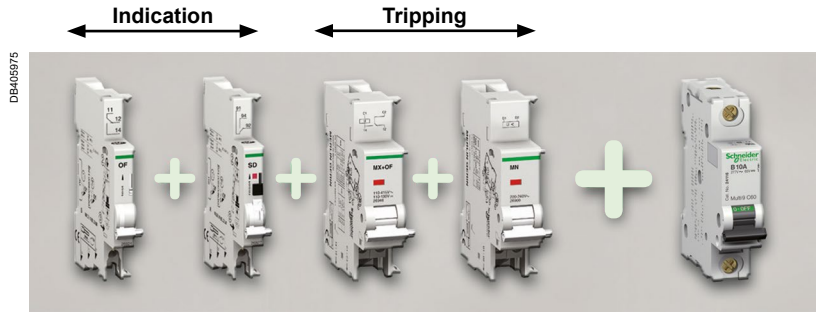

### Combination table

| Indication auxiliaries | Tripping auxiliaries               | Devices  |
|------------------------|------------------------------------|--|
| 3 SD+OF maxi           | 2 SD+OF maxi                       | PB116665-18                                      |
| 1 OF maxi              | 1 (SD+OF or SD or OF) maxi         | PB111749-19, PB111756-19<br>C60, N40N, N40 Vigi  |
| None                   | 1 OFsp                             | PB111261-18<br>RCCB-ID 125 A                     |
| None                   | 1 (OF+SD/OF or OF or OF+SD24) maxi | PB1100628, SE-30, PB116671-40                    |
| 1 OF                   | 1 OF maxi                          | OF.S + GFP 4P<br>OF.S + RCCB ID - IEC/EN 61008-1 |











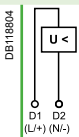

Tripping devices must be installed first.  
If two tripping devices are used: the MN undervoltage release must be installed first  
Indication auxiliaries: install the SD auxiliary first

### Railways

| Type  | MN, MNs, MNx, MX, MX+OF | OF, SD, SD+OF   |
|---|-------------------------|-----------------|
| Mass of combustible material                    | 25.5 g / 0,88 oz        | 17.6 g / 0.6 oz |
| Type of combustible material                    | PA6 GF20 FR             |                 |
| Fire and smoke requirements (EN 45545-2)        | HL2 R22 / HL2 R23       |                 |
| Resistance to shocks and vibrations (IEC 61373) | ■ Category 1            |                 |

### Tripping

| Auxiliaries   | MN   |                           |          |           |          |          | MN <sup>S</sup>  |
|---|--|---------------------------|----------|-----------|----------|----------|--|
| Type  | Undervoltage release   |                           |          |           |          |          |  |
|   | Instantaneous  |                           |          |           |          |          | Delayed  |
|   |   |                           |          |           |          |          |                                 |
| Function  | <ul style="list-style-type: none"> <li>Causes the device with which it is associated to trip when its input voltage decreases (between 70 % and 35 % of <math>U_n</math>). Prevents the device from closing until its input voltage has been restored</li> </ul> |                           |          |           |          |          | <ul style="list-style-type: none"> <li>No tripping in the event of transient voltage dips (up to 0.2 s)</li> </ul> |
| Wiring diagrams   |    |                           |          |           |          |          |  |
| Utilization   | <ul style="list-style-type: none"> <li>Emergency stop via a normally-closed pushbutton</li> <li>Improves the safety of the power supply circuits of several machines by preventing "uncontrolled" restarting</li> </ul>  |                           |          |           |          |          |  |
| Catalog numbers   | M9A27108   | M9A27107                  | M9A26960 | M9A26961  | M9A26959 | M9A26963 |  |
| <b>Technical specifications</b>   |  |                           |          |           |          |          |  |
| Rated voltage ( $U_e$ )   | V AC   | 24                        | 120      | 220...240 | 48       | 115      | 220...240  |
|   | V DC   | 24                        |          |           | 48       |          | -  |
| Operating frequency   | Hz   | 50/60                     |          |           |          | 400      | 50/60  |
| Pollution degree  |  | 3                         |          |           |          |          | 3  |
| Mechanical state indicator light, red   |  | On front face             |          |           |          |          | On front face  |
| Test function   |  | -                         |          |           |          |          | -  |
| Width in 9 mm (0.35 in) modules   |  | 2                         |          |           |          |          | 2  |
| Operating current   |  | -                         |          |           |          |          | -  |
| Number of contacts  |  | -                         |          |           |          |          | -  |
| Operating temperature   |  | -25...+50°C / -13...122°F |          |           |          |          | -25...+50°C / -13...122°F  |
| Storage temperature   |  | -40...+85°C / -40...185°F |          |           |          |          | -40...+85°C / -40...185°F  |
| <b>Standards</b>  |  |                           |          |           |          |          |  |
| IEC/EN 60947-1  |  | ■                         |          |           |          |          | ■  |
| IEC/EN 60947-5-1  |  | -                         |          |           |          |          | -  |
| EN 60947-2  |  | ■                         |          |           |          |          | ■  |
| EN 62019-2  |  | -                         |          |           |          |          | -  |
|  |  | ■                         |          |           |          |          | ■  |
|  |  | ■                         |          |           |          |          | ■  |
|  |  | ■                         |          |           |          |          | ■  |
|  |  | -                         |          |           |          |          | -  |
|  |  | ■                         |          |           |          |          | ■  |

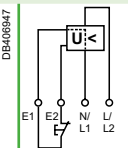
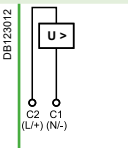
| MNx  | MX  | MX+OF   |
|--|---|---|
| Independent of the supply voltage  |   | With open/closed auxiliary contact  |
|   |                    |    |
| <ul style="list-style-type: none"> <li>Tripping of the associated device by opening of the control circuit (e.g. push-button, dry contact)</li> </ul>  | <ul style="list-style-type: none"> <li>Trips the associated device when it is powered on</li> </ul> |   |
| <ul style="list-style-type: none"> <li>A drop in the supply voltage does not trip the associated device</li> <li>A locking push-button control allows the circuit protected (e.g. machine control) to be placed in safety configuration</li> </ul>   |   | <ul style="list-style-type: none"> <li>Includes an open/closed contact (OF contact) to indicate the "open" or "closed" position of the associated device</li> </ul> |
|    |                   |   |
| <ul style="list-style-type: none"> <li>Fail-safe emergency stop</li> <li>Insensitive to the variation in the control circuit voltage to improve continuity of service</li> <li><b>Important: Before any servicing operation switch off the mains power supply (voltage presence at terminals E1/E2)</b></li> </ul> | <ul style="list-style-type: none"> <li>Emergency stop via a normally-open pushbutton.</li> </ul>    | <ul style="list-style-type: none"> <li>Emergency stop via a normally-open pushbutton</li> <li>Remote indication of the position of the associated device</li> </ul> |
| M9A26969   | M9A26971  | M9A26476   M9A26477   M9A26478   M9A26946   M9A26947   M9A26948   |
| 230  | 400   | 100...415   48   12...24   100...415   48   12...24   |
| -  | -   | 110...130   48   12...24   110...130   48   12...24   |
| 50/60  | 50/60   | 50/60   50/60   |
| 3  | 3   | 3   |
| On front face  | On front face   | On front face   |
| -  | -   | -   |
| 2  | 2   | 2   |
| -  | -   | 3 A / 415 V AC<br>6 A / ≤ 240 V AC  |
| -  | -   | 1 NO/NC   |
| -25...+50°C / -13...122°F  | -25...+50°C / -13...122°F   | -25...+50°C / -13°F...122°F   |
| -40...+85°C / -40...185°F  | -40...+85°C / -40...185°F   | -40...+85°C / -40°F...185°F   |
| ■  | ■   | ■   |
| -  | -   | -   |
| -  | -   | -   |
| -  | -   | -   |
| -  | ■   | ■   |
| -  | ■   | ■   |
| -  | ■   | ■   |
| -  | -   | ■   |
| ■  | ■   | ■   |



### Signalisation

| Auxiliaries                           | OF.S   | OFsp                           | OF   | SD  | SD+OF   |
|---------------------------------------|--|--------------------------------|--|---|---|
| <b>Type</b>                           | <b>Open/closed auxiliary contact</b>   |                                | <b>Open/closed auxiliary contact</b>   | <b>Electrical fault indicating contact</b>  | <b>Double open/closed or fault indicating contact</b>   |
|                                       |  |                                |  |   |   |
| <b>Function</b>                       | <ul style="list-style-type: none"> <li>Changeover contact indicating the "open" or "closed" position of the associated device</li> </ul> |                                | <ul style="list-style-type: none"> <li>Changeover contact indicating the "open" or "closed" position of the associated device</li> </ul> | <ul style="list-style-type: none"> <li>Changeover contact indicating the position of the associated device in the event of:                             <ul style="list-style-type: none"> <li>electrical fault</li> <li>action on the tripping auxiliary</li> </ul> </li> </ul> <p><b>⚠ Not compatible with a RCCB-ID residual current circuit breaker, use a SD+OF in the SD position</b></p> | <ul style="list-style-type: none"> <li>The SD+OF auxiliary is a two-in-one product: choice of OF or SD contact via the selector switch</li> </ul> |
| <b>Wiring diagrams</b>                |  |                                |  |   |   |
| <b>Utilization</b>                    | <ul style="list-style-type: none"> <li>Remote indication of the position of the associated device</li> </ul>                             |                                | <ul style="list-style-type: none"> <li>Remote indication of the position of the associated device</li> </ul>                             | <ul style="list-style-type: none"> <li>Remote electrical fault tripping indication of the associated device</li> </ul>  | <ul style="list-style-type: none"> <li>Remote position and/or fault tripping indication of the associated device</li> </ul>                       |
| <b>Catalog numbers</b>                | <b>26923</b>   | <b>16940</b>                   | <b>M9A26924</b>  | <b>M9A26927</b>   | <b>M9A26929</b>   |
| <b>Technical specifications</b>       |  |                                |  |   |   |
| Rated voltage (Ue) V AC               | 24...415   | 230                            | 240...415  | 240...415   | 240...415   |
| V DC                                  | 24...130   | 110                            | 24...130   | 24...130  | 24...130  |
| Operating frequency Hz                | 50/60  | 50                             | 50/60  | 50/60   | 50/60   |
| Pollution degree                      | 3  | 3                              | 3  | 3   | 3   |
| Mechanical state indicator light, red | -  | -                              | -  | On front face   | On front face   |
| Test function                         | -  | -                              | On front face  | On front face   | On front face   |
| Width in 9 mm (0.35 in) modules       | 1  | 1                              | 1  | 1   | 1   |
| Operating current                     | 3 A/415 V AC<br>6 A/≤240 V AC  | 1 A/110 V DC<br>6 A/≤230 V AC  | 3 A/415 V AC<br>6 A/≤240 V AC  | 3 A/415 V AC<br>6 A/≤240 V AC   |   |
| Number of contacts                    | 1 NO/NC  | 1 NC + NC/NO                   | 1 NO/NC  | 1 NO/NC   | 1 NO/NC + 1 NO/NC   |
| Operating temperature                 | -25...+50°C /<br>-13°F...122°F   | -25...+50°C /<br>-13°F...122°F | -25...+50°C /<br>-13°F...122°F   | -25...+50°C /<br>-13°F...122°F  | -25...+50°C /<br>-13°F...122°F  |
| Storage temperature                   | -40...+85°C /<br>-40°F...185°F   | -40...+85°C /<br>-40°F...185°F | -40...+85°C /<br>-40°F...185°F   | -40...+85°C /<br>-40°F...185°F  | -40...+85°C /<br>-40°F...185°F  |
| <b>Standards</b>                      |  |                                |  |   |   |
| IEC/EN 60947-1                        | -  | -                              | -  | -   | -   |
| IEC/EN 60947-5-1                      | ■  | -                              | ■  | ■   | ■   |
| EN 60947-2                            | -  | -                              | -  | -   | -   |
| EN 62019-2                            | ■  | -                              | ■  | ■   | ■   |
| UL                                    | -  | -                              | ■  | ■   | ■   |
| CSA                                   | -  | -                              | ■  | ■   | ■   |
| RU                                    | -  | -                              | ■  | ■   | ■   |
| CCC                                   | -  | -                              | ■  | ■   | ■   |
| COF                                   | -  | -                              | ■  | ■   | ■   |

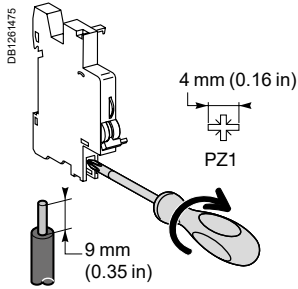

### Connection

| Type                                | Tightening torque | Copper cables   |
|-------------------------------------|-------------------|---|
| Indication and tripping auxiliaries | 1 N.m / 9 lb.in   | <b>Rigid</b>  |
|                                     |                   | DB-122946   |
| OFsp                                | 0.8 N.m / 7 lb.in | 2 cables, 1.5 mm <sup>2</sup> / #16 AWG<br>or<br>1 cable, 2.5 mm <sup>2</sup> / #14 AWG |
|                                     |                   | DB-405980   |
|                                     |                   | 1 cable, 1.5 mm <sup>2</sup> / #16 AWG  |

### Dimensions (mm / inches)

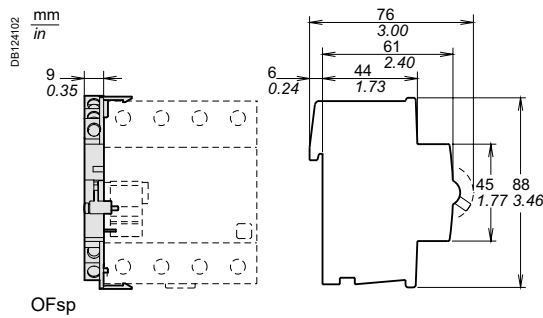
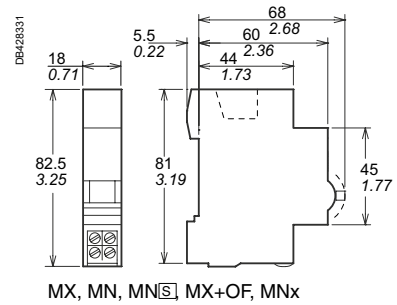
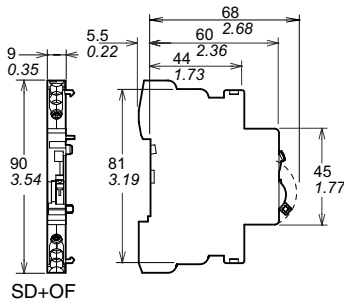
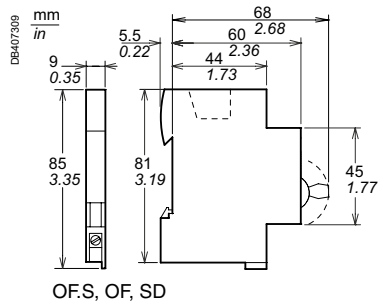

### Weight (g / oz)

| Electrical auxiliaries |                |
|------------------------|----------------|
| Type                   |                |
| MN                     | 66 g / 2.32 oz |
| MN $\square$           | 66 g / 2.32 oz |
| MNx                    | 73 g / 2.57 oz |
| MX                     | 60 g / 2.32 oz |
| MX+OF                  | 65 g / 2.12 oz |
| OF.S                   | 33 g / 1.16 oz |
| OF                     | 30 g / 1.06 oz |
| OFsp                   | 40 g / 1.41 oz |
| SD                     | 30 g / 1.06 oz |
| SD+OF                  | 38 g / 1.34 oz |

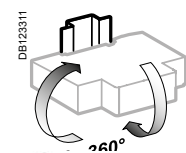
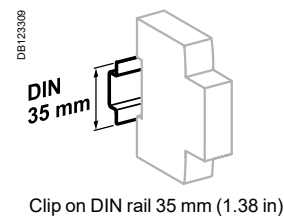
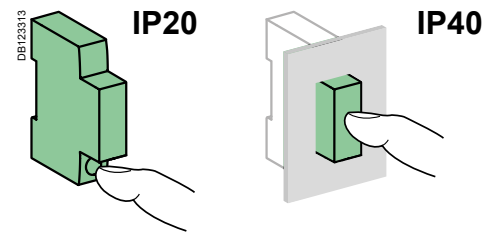

### C60BP or C60BPR association

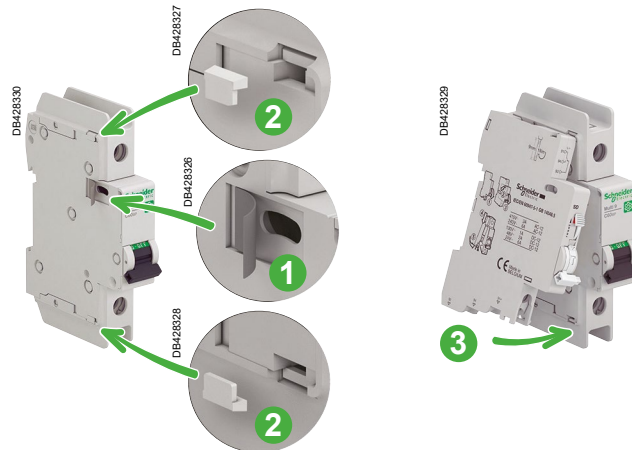

■ The electrical auxiliaries are combined with iID residual current circuit breakers; they enable tripping or remote indication of their position (open/closed/tripped) upon an electrical fault.

■ They are fastened by clips (without tools) to the left side of the breaker.

■ The iOF/SD+OF auxiliary is a 2-in-1 product: via a mechanical selector switch, it provides two contacts, OF+SD or OF+OF.

■ The iOF+SD24 auxiliary can report open/closed (OF) status information and intentional or fault tripping of the associated device (SD) to the Acti9 Smartlink or a programmable logic controller via the Ti24 interface (24 V DC).

### Tripping auxiliaries:

#### IEC/EN 60947-1

- iMN: undervoltage release
- iMNs: delayed undervoltage release
- iMNx: undervoltage release, independent from supply voltage
- iMX: shunt release
- iMX+OF: shunt release with open/close contact.

#### EN 50550

- iMSU: overvoltage release.



### Indication auxiliaries:

#### IEC/EN 60947-5-1



- iOF: open/close contact
- iSD: electrical fault indicating contact
- iOF/SD+OF: open/close contact and switchable OF or SD contact
- iOF+SD24: open/close contact OF and fault indicating contact SD with Ti24 interface.



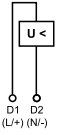
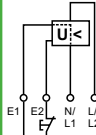

#### IEC/EN 60947-5-4

- iOF+SD24: open/close contact OF and fault indicating contact SD with Ti24 interface.

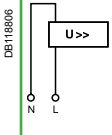
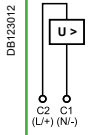
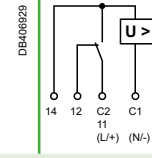
|  |                             | Tripping   |                 |   |                             |   |                 |                 |
|--|-----------------------------|--|-----------------|---|-----------------------------|---|-----------------|-----------------|
| Auxiliaries  |                             | iMN  |                 | iMNs  |                             | iMNx  |                 |                 |
| Type   |                             | Undervoltage release   |                 |   |                             |   |                 |                 |
|  |                             | Instantaneous  |                 | Delayed   |                             | Independent of the supply voltage   |                 |                 |
|  |                             |   |                 |                      |                             |    |                 |                 |
| <b>Function</b>  |                             | <ul style="list-style-type: none"> <li>Trips the device with which it is combined when its input voltage decreases (between 70 % and 35 % Un).</li> <li>Prevents device closing again until its input voltage is restored</li> </ul> |                 | <ul style="list-style-type: none"> <li>Not tripping on transient voltage dip (up to 0.2 s)</li> </ul> |                             | <ul style="list-style-type: none"> <li>Tripping of the associated device by opening of the control circuit (e.g. push-button, dry contact)</li> <li>A drop in the supply voltage does not trip the associated device</li> <li>A locking push-button control allows the circuit protected (e.g. machine control) to be placed in safety configuration</li> </ul> |                 |                 |
| <b>Wiring diagrams</b>   |                             |   |                 |   |                             |    |                 |                 |
| <b>Use</b>   |                             | <ul style="list-style-type: none"> <li>Emergency stoppage by normally closed push button</li> <li>Improve the safety of power supply circuits for several machines by preventing "uncontrolled" restarting</li> </ul>                |                 |   |                             | <ul style="list-style-type: none"> <li>Emergency stoppage with fail-safe principle</li> <li>Insensitive to control circuit voltage variation to increase service continuity</li> <li><b>Important: Before any servicing operation switch off the mains power supply (voltage presence at terminals E1/E2)</b></li> </ul>  |                 |                 |
| <b>Catalog numbers</b>   |                             | <b>A9A26960</b>  | <b>A9A27108</b> | <b>A9A26961</b>   | <b>A9A26959</b>             | <b>A9A26963</b>   | <b>A9A26969</b> | <b>A9A26971</b> |
| iID  |                             | ■  | ■               | ■   | ■                           | ■   | ■               | ■               |
| <b>Technical specifications</b>                                |                             |  |                 |   |                             |   |                 |                 |
| Rated voltage (Ue)   | 220...240 V AC              | 24 V AC  | 48 V AC         | 115 V AC  | 220...240 V AC              | 220...240 V AC  | 380...415 V AC  |                 |
|  | –                           | 24 V DC  | 48 V CC         | –   | –                           | –   | –               | –               |
| Standardised operating and non-response to voltage times (Ua)* | –                           | –  | –               | –   | –                           | –   | –               | –               |
| Maximum operating time   | –                           | –  | –               | –   | –                           | –   | –               | –               |
| Minimum non-response time                                      | –                           | –  | –               | –   | –                           | –   | –               | –               |
| Operating frequency  | 50/60 Hz                    |  |                 | 400 Hz  | 50/60 Hz                    | 50/60 Hz  |                 |                 |
| Red mechanical indicator                                       | On front face               |  |                 |   | On front face               | On front face   |                 |                 |
| Test function  | –                           |  |                 |   | –                           | –   |                 |                 |
| Width in 9 mm (0.35 in) modules                                | 2                           |  |                 |   | 2                           | 2   |                 |                 |
| Operating current  | –                           |  |                 |   | –                           | –   |                 |                 |
| Number of contacts   | –                           |  |                 |   | –                           | –   |                 |                 |
| Operating temperature  | -35...+70°C / -31°F...158°F |  |                 |   | -35...+70°C / -31°F...158°F | -35...+70°C / -31°F...158°F   |                 |                 |
| Storage temperature  | -40...+85°C / -40°F...185°F |  |                 |   | -40...+85°C / -40°F...185°F | -40...+85°C / -40°F...185°F   |                 |                 |

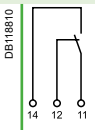
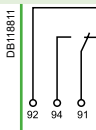
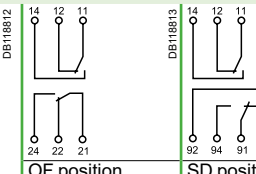
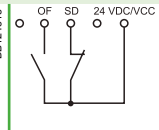

| iMSU  |          | iMX   |                 |                 | iMX+OF  |                 |                 |
|---|----------|---|-----------------|-----------------|---|-----------------|-----------------|
| Overvoltage release   |          | Shunt release   |                 |                 | With Open/Close auxiliary contact   |                 |                 |
|    |          |                    |                 |                 |    |                 |                 |
| <ul style="list-style-type: none"> <li>Switches off the power supply by opening the breaker with which it is combined, in the event that the phase/neutral voltage is exceeded (loss of neutral). For a four-phase network, use three iMSU tripping auxiliaries.</li> </ul> |          | <ul style="list-style-type: none"> <li>Trips the associated device when it is powered on</li> </ul> |                 |                 | <ul style="list-style-type: none"> <li>Includes an open/close contact (OF) to indicate the "open" or "closed" position of the device</li> </ul>                       |                 |                 |
|    |          |                  |                 |                 |    |                 |                 |
| <ul style="list-style-type: none"> <li>Protection of equipment against overvoltages on the electrical network (neutral conductor break)</li> <li>Voltage monitoring between phase and neutral conductors</li> </ul>   |          | <ul style="list-style-type: none"> <li>Emergency stoppage by normally open push button</li> </ul>   |                 |                 | <ul style="list-style-type: none"> <li>Emergency stoppage by normally open push button</li> <li>Remote indication of the position of the associated device</li> </ul> |                 |                 |
| <b>A9A26500</b>   |          | <b>A9A26476</b>   | <b>A9A26477</b> | <b>A9A26478</b> | <b>A9A26946</b>   | <b>A9A26947</b> | <b>A9A26948</b> |
| 230 V AC  |          | 100...415 V AC  | 48 V AC         | 12...24 V AC    | 100...415 V AC  | 48 V AC         | 12...24 V AC    |
| -   |          | 110...130 V DC  | 48 V DC         | 12...24 V DC    | 110...130 V DC  | 48 V DC         | 12...24 V DC    |
| 255 V AC  | 275 V AC | 300 V AC  | 350 V AC        | 400 V AC        | -   | -               | -               |
| No tripping   | 15 s     | 5 s   | 0.75 s          | 0.20 s          | -   | -               | -               |
|   | 3 s      | 1 s   | 0.25 s          | 0.07 s          | -   | -               | -               |
| 50/60 Hz  |          | 50/60 Hz  |                 |                 | 50/60 Hz  |                 |                 |
| On front face   |          | On front face   |                 |                 | On front face   |                 |                 |
| -   |          | -   |                 |                 | -   |                 |                 |
| 2   |          | 2   |                 |                 | 2   |                 |                 |
| -   |          | -   |                 |                 | 10 mA mini, 6 A maxi  |                 |                 |
| -   |          | -   |                 |                 | ≤ 24 V DC   |                 | 6 A             |
| -   |          | -   |                 |                 | 48 V DC   |                 | 2 A             |
| -   |          | -   |                 |                 | ≤ 130 V DC  |                 | 1 A             |
| -   |          | -   |                 |                 | ≤ 240 V AC  |                 | 6 A             |
| -   |          | -   |                 |                 | 415 V AC  |                 | 3 A             |
| -   |          | -   |                 |                 | 1 NO/NC   |                 |                 |
| -35...+70°C / -31°F...158°F   |          | -35...+70°C / -31°F...158°F   |                 |                 | -35...+70°C / -31°F...158°F   |                 |                 |
| -40...+85°C / -40°F...185°F   |          | -40...+85°C / -40°F...185°F   |                 |                 | -40...+85°C / -40°F...185°F   |                 |                 |

|                                 |  | Indication   |   |   |  |
|---------------------------------|--|--|---|---|--|
| Auxiliaries                     | iOF  | iSD  | iOF/SD+OF   | iOF+SD24  |  |
| Type                            | Open/close auxiliary contact   | Electrical fault indicating contact  | Double open/close or fault indicating contact   | Double open/close and fault indicating contact  |  |
|                                 |   |   |    |    |  |
| Function                        | <ul style="list-style-type: none"> <li>Changeover contact indicates "open" or "closed" position of the device</li> </ul> | <ul style="list-style-type: none"> <li>Changeover contact indicates position of the device; upon:                             <ul style="list-style-type: none"> <li>electrical fault</li> <li>action on tripping auxiliary</li> </ul> </li> <li>Same indication as VISI-TRIP</li> </ul> | <ul style="list-style-type: none"> <li>The iOF/SD+OF auxiliary is a 2-in-1 product: via a mechanical selector switch, it provides two contacts, OF+SD or OF+OF</li> </ul> | <ul style="list-style-type: none"> <li>2 contacts (1 NO + 1 NC) can report the signalling information of the associated device to the Acti9 Smartlink or a programmable logic controller:                             <ul style="list-style-type: none"> <li>electrical fault</li> <li>actuation of the tripping auxiliary</li> <li>"Open" or "Closed" position of the associated device</li> </ul> </li> </ul> |  |
| Wiring diagrams                 |                                       |   |   |    |  |
| Use                             | <ul style="list-style-type: none"> <li>Remote indication of the position of the associated device</li> </ul>             | <ul style="list-style-type: none"> <li>Remote indication of tripping upon an electrical fault of the associated device</li> </ul>  | <ul style="list-style-type: none"> <li>Remote indication of position and/or tripping upon an electrical fault of the associated device</li> </ul>                         | <ul style="list-style-type: none"> <li>Remote indication of position and tripping upon an electrical fault of the associated device</li> </ul>  |  |
| Catalog numbers                 | <b>A9A26869</b>  | <b>A9A26855</b>  | <b>A9A26929</b>   | <b>A9A26897</b>   |  |
| iID double terminals            | ■  | ■  | ■   | ■   |  |
| <b>Technical specifications</b> |  |  |   |   |  |
| Rated voltage (Ue)              | 24...415 V AC<br>24...130 V DC   | 24...415 V AC<br>24...130 V DC   | 24...415 V AC<br>24...130 V DC  | -<br>24 V DC  |  |
| Operating frequency             | 50/60 Hz   | 50/60 Hz   | 50/60 Hz  | -   |  |
| Red mechanical indicator        | -  | On front face  | On front face   | On front face   |  |
| Test function                   | On toggle  | On toggle  | On toggle   | On toggle   |  |
| Width in 9 mm (0.35 in) modules | 1  | 1  | 1   | 1   |  |
| Operating current               | 10 mA mini, 6 A maxi<br>24 V DC 6 A<br>48 V DC 2 A<br>60 V DC 1,5 A<br>130 V DC 1 A<br>24...240 V AC 6 A<br>415 V AC 3 A |  |   | 2 mA mini, 100 mA maxi  |  |
| Number of contacts              | 1 NO/NC  | 1 NO/NC  | 1 NO/NC + 1 NO/NC   | 1 NO/NC   |  |
| Operating temperature           | -35...+70°C / -31°F...158°F  | -35...+70°C / -31°F...158°F  | -35...+70°C / -31°F...158°F   | -25...+70°C / -13°F...158°F   |  |
| Storage temperature             | -40...+85°C / -40°F...185°F  | -40...+85°C / -40°F...185°F  | -40...+85°C / -40°F...185°F   | -40...+85°C / -40°F...185°F   |  |

## Connection

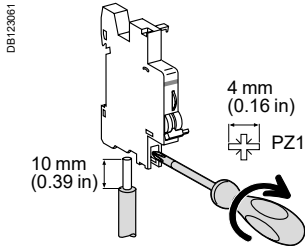

| Type                   | Tightening torque  | Copper cables                           |   | Multi-cables                          |                                       |
|------------------------|--------------------|---|---|---------------------------------------|---------------------------------------|
|                        |                    | Rigid                                   | Flexible                                    | Rigid                                 | Cables with ferrule                   |
|                        |                    | DB122945                                | DB123007                                    | DB123011                              | DB123008                              |
| Indication auxiliaries | 1 N.m / 8.85 lb.in | 1 to 4 mm <sup>2</sup> / AWG #18 to #12 | 0.5 to 2.5 mm <sup>2</sup> / AWG #20 to #14 | 2 x 2.5 mm <sup>2</sup> / 1 x AWG #14 | 2 x 1.5 mm <sup>2</sup> / 1 x AWG #16 |
| Tripping auxiliaries   | 1 N.m / 8.85 lb.in | 1 to 6 mm <sup>2</sup> / AWG #18 to #10 | 0.5 to 4 mm <sup>2</sup> / AWG #20 to #12   | 2 x 2.5 mm <sup>2</sup> / 1 x AWG #14 | 2 x 2.5 mm <sup>2</sup> / 1 x AWG #14 |

## Ti24 connector connection

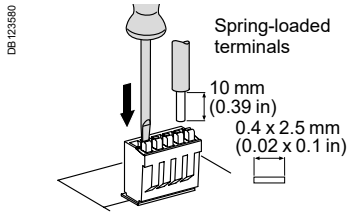

| Type           | Catalog numbers | Copper cables                                       |   |
|----------------|-----------------|---|---|
|                |                 | Rigid   | Flexible  |
|                |                 | DB122945  | DB123553  |
| Ti24 interface | <b>A9XC2412</b> | 1 x 0.5 to 1.5 mm <sup>2</sup> / 1 x AWG #20 to #16 | 1 x 0.5 to 1.5 mm <sup>2</sup> / 1 x AWG #20 to #16 |

## Ti24 prefabricated cables connection

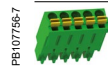
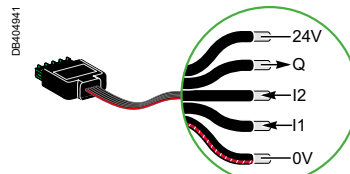

| Type                                     | Catalog numbers | Length              |
|--|-----------------|---------------------|
| <b>Connection for Acti9 Smartlink</b>    |                 |                     |
| 6 prefabricated                          | <b>A9XCAS06</b> | 100 mm (3.94 in)    |
|  | <b>A9XCAM06</b> | 160 mm (6.3 in)     |
|  | <b>A9XCAH06</b> | 450 mm (17.72 in)   |
|  | <b>A9XCAL06</b> | 870 mm (34.25 in)   |
| <b>Connection for PLC type terminals</b> |                 |                     |
| 6 long prefabricated on a single side    | <b>A9XCAU06</b> | 870 mm (34.25 in)   |
| 1 long prefabricated on a single side    | <b>A9XCAC01</b> | 4000 mm (157.48 in) |
| 12 connectors, 5-pins (Ti24)             | <b>A9XC2412</b> | -                   |

## Technical data

### Weight (g / oz)

| Electrical auxiliaries |                |
|------------------------|----------------|
| Type                   |                |
| iMN                    | 69 g / 2.43 oz |
| iMNs                   | 72 g / 2.54 oz |
| iMNx                   | 79 g / 2.79 oz |
| iMSU                   | 68 g / 2.4 oz  |
| iMX                    | 64 g / 2.26 oz |
| iMX+OF                 | 68 g / 2.4 oz  |
| iOF                    | 32 g / 1.13 oz |
| iSD                    | 33 g / 1.16 oz |
| iOF/SD+OF              | 43 g / 1.52 oz |
| iOF+SD24               | 25 g / 0.88 oz |

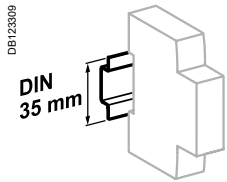

Clip on DIN rail 35 mm (1.38 in)

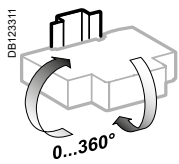

Indifferent position of installation

## Dimensions (mm / inches)

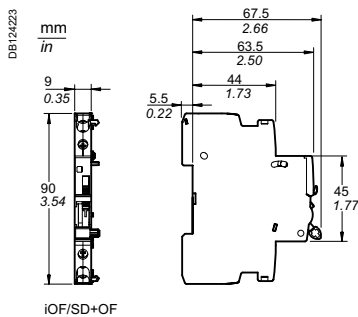

iOF/SD+OF

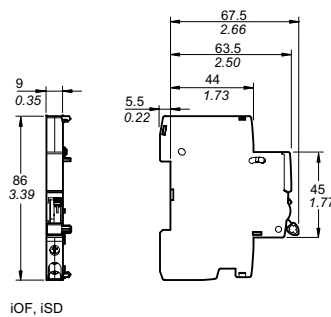

iOF, iSD

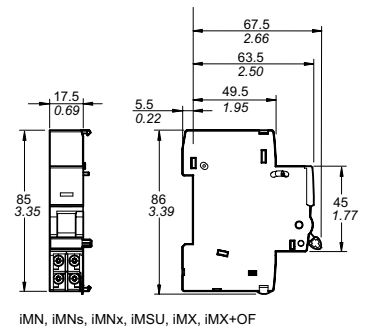

iMN, iMNs, iMNx, iMSU, iMX, iMX+OF

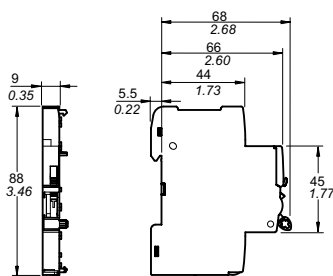

iOF+SD24 (A9A26897)

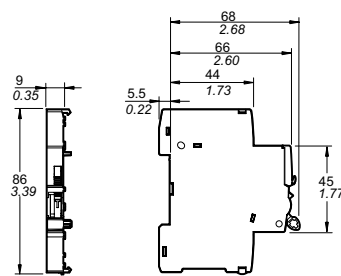

iOF+SD24 (A9A26898)



**Installation**

**Accessories**

**Rotary handle**

**Plug-in base**

PB100137\_SE-24 PB100138\_SE-24



PB111764-40



**Function**

**Front or side control of 2, 3 and 4-pole circuit breakers**

- Degree of protection: IP40
- A complete rotary handle consists of:
  - a circuit breaker operating sub-assembly, cat. no. **27046**,
  - a handle cat. no. **27047** or a handle cat. no. **27048**
- Installation:
  - the circuit breaker operating sub-assembly cat. no. **27046** is fixed to the circuit breaker
  - the removable handle cat. no. **27047** is mounted on the removable front panel or on the enclosure door
  - the fixed handle cat. no. **27048** is fixed to the front or side panel of the enclosure

**Allows a circuit breaker to be quickly removed or replaced, without touching the connections**

- Degree of protection: IP20
- It consists of:
  - a base to be fixed to a rail (or panel)
  - 2 "blades" to be fixed in the device terminals
- Connection: tunnel terminals for cables up to 50 mm<sup>2</sup> (rigid) or 35 mm<sup>2</sup> (flexible)
- Installation:
  - on backplate
  - on a horizontal rail
  - Centreline between two rows: 200 mm (7.87 in)
  - Only on the circuit breaker, without a Vigi device or auxiliary
  - Padlocking option: 8 mm (0.31 in) diameter, padlock not supplied)

**Cat. numbers**

**27047**

Removable extended handle

**27048**

Fixed handle

**27046**

Operating sub-assembly

**26996**

(1 per pole)

**Set of**

1

1

1

1

**Suitable for the following devices:**

**C60<sub>BP</sub> UL489,**  
**C60<sub>BPR</sub> UL489**

- 2P, 3P

—

**C60<sub>SP</sub> UL1077**

- 2P, 3P, 4P

■

**C60<sub>H-DC</sub>**

- 2P

■

**GFP UL1053**

—

■

**C60<sub>N</sub>, H, L,**  
**C60<sub>CTRL</sub>**

- 2P, 3P, 4P

■

**N40<sub>N</sub>**

- 3P+N

—

**RCCB-ID 125 A**

—

—

**N40 Vigi**

—

—



Operating temperature



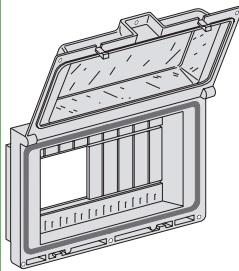
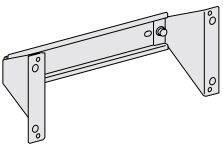

-35°C to +70°C /  
-31°F to 158°F

-35°C to +70°C /  
-31°F to 158°F



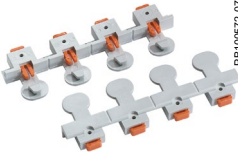

| Accessories  |  | Padlocking device  |  |   |
|--|--|--|--|---|
|  |  | Front  | Side   |   |
|  |   |   |    |  |
|  | 05720A_SE-20   | DB409566-25  | AGA26380-40  | AGA26381-40   |
| <b>Function</b>                                      | <p>Used to padlock a circuit breaker in the "open" or "closed" position</p> <ul style="list-style-type: none"> <li>Locking in the ON position does not prevent the circuit breaker from tripping in the event of an electrical fault</li> <li>Isolation: in conformity with IEC/EN 60947-2.</li> <li>Diameter of the padlock: 8 mm (0.31 in) max.</li> </ul> | <p>Used to padlock a circuit breaker in the "open" position</p> <ul style="list-style-type: none"> <li>Isolation: in conformity with UL 489/CSA C22.2 No 5 Listed and UL 1077 Recognized.</li> <li>Diameter of the padlock: 8 mm (0.31 in) max.</li> </ul> | <p>Can be used to padlock a circuit breaker in open position</p> <ul style="list-style-type: none"> <li>Attached directly to the circuit breaker, it cannot be lost</li> <li>Padlock diameter: 6 mm (0.24 in)</li> </ul> |   |
| <b>Cat. numbers</b>                                  | 26970  | M9PAF  | MGN26380<br>Left-hand mounting   | MGN26381<br>Right-hand mounting   |
| <b>Set of</b>  | 2  | 1  | 1  | 1   |
| <b>Suitable for the following devices:</b>           |  |  |  |   |
| C60 <sub>BP</sub> UL489,<br>C60 <sub>BPR</sub> UL489 | ■  | ■  | ■  | ■   |
| C60 <sub>SP</sub> UL1077                             | ■  | ■  | ■  | ■   |
| C60 <sub>H-DC</sub>                                  | ■  | ■  | ■  | ■   |
| GFP UL1053   | ■  | —  | —  | —   |
| C60 <sub>N</sub> , H, L,<br>C60 <sub>CTRL</sub>      | ■  | ■  | ■  | ■   |
| N40N   | ■  | ■  | ■  | ■   |
| RCCB-ID 125 A  | —  | —  | —  | —   |
| N40 Vigi   | ■  | —  | —  | —   |
| Operating temperature                                | -35°C to +70°C /<br>-31°F to 158°F   | -35°C to +70°C /<br>-31°F to 158°F   | -35°C to +70°C /<br>-31°F to 158°F   | -35°C to +70°C /<br>-31°F to 158°F  |

## Installation (continued)

| Accessories  | Front mounting kit  |  | Pole filler  | Front mounting bracket   |                |                |                |                |
|--|---|--|--|--|----------------|----------------|----------------|----------------|
|  | Front mounting kit  | DIN rail support   |  |  |                |                |                |                |
|  |    |   |   |   |                |                |                |                |
| <b>Function</b>  | <ul style="list-style-type: none"> <li>Consists of a transparent, hinged, weatherproof cover</li> <li>Allows installation of up to twenty modules (10 poles of C60) of circuit breakers or supplementary protectors and accessories</li> <li>A DIN rail with support is also available</li> <li>Degree of protection as per IEC 529: IP55</li> <li>Includes a 10-Module divisible blanking plate and mounting template</li> </ul> | <ul style="list-style-type: none"> <li>DIN rail with support for front mounting kit cat. no. 14210</li> <li>Allows installation of up to twenty modules (10 poles of C60) of circuit breakers or supplementary protectors and accessories</li> </ul> | <ul style="list-style-type: none"> <li>Used to fill empty panels spaces</li> <li>They clip into space</li> <li>They may be snapped apart in 9 mm (0.35 in) increments</li> </ul> | <ul style="list-style-type: none"> <li>Provides a convenient way to mount circuit breakers, supplementary protectors or accessories</li> <li>Allows the C60 devices to be clipped onto it in a standard manner</li> <li>In 480 V AC UL 1077 applications, cat. no. 26981 terminal screw shield should be used for increased isolation between the terminal screws of the device and the mounting bracket. These shields are included with the mounting bracket kits</li> </ul> |                |                |                |                |
| <b>Cat. numbers</b>  | <b>14210</b>  | <b>14211</b>   | <b>M9PF4</b>   | <b>M9PF5</b>   | <b>MG26983</b> | <b>MG26984</b> | <b>MG26985</b> | <b>MG26989</b> |
|  |   |  | 4 strips of 4 by 18 mm (0.71 in) pole filler   | 4 strips of 5 by 18 mm (0.71 in) pole filler   |                |                |                |                |
| <b>Set of</b>  | <b>1</b>  | <b>1</b>   | <b>4</b>   | <b>4</b>   | <b>1</b>       |                |                |                |
| <b>Suitable for the following devices:</b>                       |   |  |  |  |                |                |                |                |
| <b>C60<sub>BP</sub> UL489,</b><br><b>C60<sub>BPR</sub> UL489</b> | <input type="checkbox"/>  | For multi-pole mounting kit cat. no.14210  | For multi-pole mounting kit cat. no.14210  | <input type="checkbox"/>   |                |                |                |                |
| <b>C60<sub>SP</sub> UL1077</b>                                   | <input type="checkbox"/>  |  |  | <input type="checkbox"/>   |                |                |                |                |
| <b>C60<sub>H-DC</sub></b>  | <input type="checkbox"/>  |  |  | <input type="checkbox"/>   |                |                |                |                |
| <b>GFP UL1053</b>  | <input type="checkbox"/>  |  |  | <input type="checkbox"/>   |                |                |                |                |
| <b>C60N, H, L,</b><br><b>C60<sub>CTRL</sub></b>                  | <input type="checkbox"/>  |  |  | <input type="checkbox"/>   |                |                |                |                |
| <b>N40N</b>  | <input type="checkbox"/>  |  |  | <input type="checkbox"/>   |                |                |                |                |
| <b>RCCB-ID 125 A</b>   | <input type="checkbox"/>  |  |  | <input type="checkbox"/>   |                |                |                |                |
| <b>N40 Vigi</b>  | <input type="checkbox"/>  |  |  | <input type="checkbox"/>   |                |                |                |                |
| Operating temperature  | -35°C to +70°C /<br>-31°F to 158°F  |  |  | -35°C to +70°C /<br>-31°F to 158°F   |                |                |                |                |





| Security                                   |  |   |   |   |  |                                 |
|--|--|---|---|---|--|---------------------------------|
| Accessories                                | Screw shield   |   | Terminal shield   | Interpole barrier   | Spacer   |                                 |
|  |   |  |    |  |   |                                 |
| <b>Function</b>                            | <b>Prevents all contact with the fixing screws</b> <ul style="list-style-type: none"> <li>The degree of protection becomes IP40</li> <li>Sealable, max. diameter 1.2 mm (0.05 in)</li> </ul> |   | <b>Prevents all contact with the terminals</b> <ul style="list-style-type: none"> <li>Degree of protection becomes IP40</li> <li>Sealable, max. diameter 1.2 mm (0.05 in)</li> <li>1P <input type="checkbox"/> 2P <input type="checkbox"/></li> <li>3P: 1 x 26975 + 1 x 26976</li> <li>4P: 2 x 26976</li> </ul> |   | <b>Improves the insulation between the connections: cables, terminals, lugs, etc.</b> <ul style="list-style-type: none"> <li>Used to:               <ul style="list-style-type: none"> <li>complete the rows</li> <li>separate the devices</li> </ul> </li> <li>Width: 1 x 9 mm (0.35 in) module</li> <li>Allows that 2 cables are routed from one row to another (above and below), up to 6 mm<sup>2</sup></li> </ul> |                                 |
| <b>Cat. numbers</b>                        | 26981  | 16939   | 26975   | 26976   | 27001  | 27062                           |
| <b>Set of</b>                              | 2 (4P dividable)   | 10  | 2 (for upstream/downstream terminal)  |   | 10   | 1                               |
| <b>Suitable for the following devices:</b> |  |   |   |   |  |                                 |
| C60 <sup>BP</sup> UL489,                   | -  | -   | -   | -   | -  | ■                               |
| C60 <sup>BPR</sup> UL489                   | -  | -   | -   | -   | -  | ■                               |
| C60 <sup>SP</sup> UL1077                   | ■  | -   | ■   | ■   | ■  | ■                               |
| C60 <sup>H-DC</sup>                        | ■  | -   | ■   | ■   | ■  | ■                               |
| GFP UL1053                                 | ■  | -   | -   | -   | -  | ■                               |
| C60N, H, L,                                | ■  | -   | ■   | ■   | ■  | ■                               |
| C60 <sup>CTRL</sup>                        | -  | -   | -   | -   | -  | ■                               |
| N40N                                       | -  | -   | -   | -   | -  | ■                               |
| RCCB-ID 125 A                              | -  | ■   | -   | -   | -  | ■                               |
| N40 Vigi                                   | -  | -   | -   | -   | -  | ■                               |
| Operating temperature                      | -35°C to +70°C / -31°F to 158°F  | -35°C to +70°C / -31°F to 158°F   | -35°C to +70°C / -31°F to 158°F   |   | -35°C to +70°C / -31°F to 158°F  | -35°C to +70°C / -31°F to 158°F |



| Connection                                 |   |   |  |                                 |
|--|---|---|--|---------------------------------|
| Accessories                                | Multi-cable terminal  | 50 mm <sup>2</sup> / #1 AWG Al terminal   | Connection kit for ring terminals  |                                 |
|  |    |  |   |                                 |
|  | DB10334_SE-19   | DB122651  | DB409586   |                                 |
| <b>Function</b>                            | <b>For 3 copper cables:</b> <ul style="list-style-type: none"> <li>Rigid up to 16 mm<sup>2</sup></li> <li>Flexible up to 10 mm<sup>2</sup></li> </ul> | <b>For 16 to 50 mm<sup>2</sup> aluminium cables</b>                               | <b>For terminal up to 63 A, front or rear access</b> <ul style="list-style-type: none"> <li>It incorporates a "conductive" part and an "insulating" part which ensures the phase-to-phase clearance</li> </ul> |                                 |
|  |    |  |  |                                 |
|  | DB116787  | DB122935  |  |                                 |
| <b>Cat. numbers</b>                        | <b>19091</b>  | <b>19096</b>  | <b>27060</b>   | <b>M9A17400</b>                 |
| <b>Set of</b>                              | <b>4</b>  | <b>3</b>  | <b>1</b>   | <b>24</b>                       |
| <b>Suitable for the following devices:</b> |   |   |  |                                 |
| <b>C60<sub>BP</sub> UL489,</b>             | –   | –   | –  | –                               |
| <b>C60<sub>BPR</sub> UL489</b>             | –   | –   | –  | –                               |
| <b>C60<sub>SP</sub> UL1077 ≤ 25 A</b>      | –   | –   | –  | ■                               |
| <b>C60<sub>SP</sub> UL1077 &gt; 25 A</b>   | ■   | ■   | –  | ■                               |
| <b>GFP UL1053</b>                          | ■   | ■   | –  | –                               |
| <b>C60N, H, L, ≤ 25 A</b>                  | –   | –   | –  | ■                               |
| <b>C60<sub>CTRL</sub></b>                  | –   | –   | –  | –                               |
| <b>C60N, H, L, &gt; 25 A</b>               | ■   | ■   | ■  | ■                               |
| <b>C60<sub>CTRL</sub></b>                  | –   | –   | –  | –                               |
| <b>C60<sub>H-DC</sub> ≤ 25 A</b>           | –   | –   | –  | ■                               |
| <b>C60<sub>H-DC</sub> &gt; 25 A</b>        | ■   | ■   | ■  | ■                               |
| <b>N40N</b>                                | –   | –   | –  | –                               |
| <b>RCCB-ID 125 A</b>                       | –   | –   | –  | –                               |
| <b>N40 Vigi</b>                            | –   | –   | –  | –                               |
| <b>Tightening torque</b>                   | 2 N.m (18 lb.in)  | –   | 10 N.m (89 lb.in)  | 2 N.m (18 lb.in)                |
| <b>Stripping length</b>                    | 11 mm (0.43 in)   | –   | 13 mm (0.51 in)  | –                               |
| <b>Tools to be used</b>                    | Flat 5 mm (0.2 in) or PZ2   | –   | Hc 1/5" or 5 mm (0.2 in)   | Flat 5 mm (0.2 in) or PZ2       |
| <b>Operating temperature</b>               | -35°C to +70°C / -31°F to 158°F   | –   | -35°C to +70°C / -31°F to 158°F  | -35°C to +70°C / -31°F to 158°F |



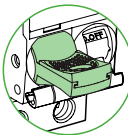

| Identification                             |  |           |           |               |
|--|--|-----------|-----------|---------------|
| Accessories                                | Clip-on terminal marker strip  |           |           |               |
|  |  |           |           |               |
|  | 031204D_SE-23  |           |           |               |
| <b>Function</b>                            | <b>For connection identification</b>   |           |           |               |
| <b>Cat. numbers</b>                        | 0: AB1-R0  | A: AB1-GA | K: AB1-GK | U: AB1-GU     |
|  | 1: AB1-R1  | B: AB1-GB | L: AB1-GL | V: AB1-GV     |
|  | 2: AB1-R2  | C: AB1-GC | M: AB1-GM | W: AB1-GW     |
|  | 3: AB1-R3  | D: AB1-GD | N: AB1-GN | X: AB1-GX     |
|  | 4: AB1-R4  | E: AB1-GE | O: AB1-GO | Y: AB1-GY     |
|  | 5: AB1-R5  | F: AB1-GF | P: AB1-GP | Z: AB1-GZ     |
|  | 6: AB1-R6  | G: AB1-GG | Q: AB1-GQ | + : AB1-R12   |
|  | 7: AB1-R7  | H: AB1-GH | R: AB1-GR | - : AB1-R13   |
|  | 8: AB1-R8  | I: AB1-GI | S: AB1-GS | Blank: AB1-RV |
|  | 9: AB1-R9  | J: AB1-GJ | T: AB1-GT |               |
| <b>Set of</b>                              | <b>250</b>   |           |           |               |
| <b>Suitable for the following devices:</b> |  |           |           |               |
| <b>C60<sub>BP</sub> UL489</b>              | –  |           |           |               |
| <b>C60<sub>BPR</sub> UL489</b>             | –  |           |           |               |
| <b>C60<sub>SP</sub> UL1077</b>             | ■ 4 markers max. per pole  |           |           |               |
| <b>C60<sub>H-DC</sub></b>                  | ■ 4 markers max. per pole  |           |           |               |
| <b>GFP UL1053</b>                          | ■ 4 markers max. per pole  |           |           |               |
| <b>C60<sub>H-DC</sub></b>                  | ■ 4 markers max. per pole  |           |           |               |
| <b>C60N, H, L, C60<sub>CTRL</sub></b>      | ■ 4 markers max. per pole  |           |           |               |
| <b>N40N</b>                                | ■ 4 markers max. per pole  |           |           |               |
| <b>RCCB-ID 125 A</b>                       | –  |           |           |               |





## Mounting

| Accessories | Rotary handle   | Plug-in base   | Padlocking device   |  |
|-------------|---|--|---|--|
|             |   |  | Front   | Side   |
| PB104509-35 |  | PB104509-35<br> | PB104492-15<br><br>DB123599<br> | A9A26380-40<br> |

## Function

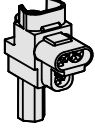
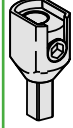
|                        |  |  |  |   |   |          |                    |
|------------------------|--|--|--|---|---|----------|--------------------|
|                        | <p><b>Front or side-mounted control rotary handle</b></p> <ul style="list-style-type: none"> <li>■ Degree of protection: IP55</li> <li>■ Installation:           <ul style="list-style-type: none"> <li>□ the control mechanism is mounted on the device</li> <li>□ the rotary handle is fixed to the front or side of the enclosure</li> </ul> </li> <li>■ Front-mounted (on door or faceplate)</li> <li>■ Prevents the door from opening when the device is in the ON position (can be deactivated)</li> <li>■ Can be padlocked when the device is in the "open" position (can be padlocked with the device in the "closed" position subject to adaptation)</li> <li>■ Can be locked by padlock of (dia. 5 to 8 mm / 0.2 to 0.31 in), not supplied with the device</li> <li>■ Pushbutton: iID test available in the front face of the rotary handle</li> </ul> | <ul style="list-style-type: none"> <li>■ The Laser Square tool brings the accuracy to align the breaker and the rotary handle</li> </ul> | <p><b>Allows a breaker to be removed or replaced quickly, without handling the connections</b></p> <ul style="list-style-type: none"> <li>■ Degree of protection: IP20</li> <li>■ Consists of:           <ul style="list-style-type: none"> <li>□ a base to be fastened on a rail (or panel)</li> <li>□ 2 "blades" to be fastened in the device's terminals</li> </ul> </li> <li>■ Connection: tunnel terminals for cable up to 35 mm<sup>2</sup> rigid, 25 mm<sup>2</sup> flexible,</li> <li>■ Installation:           <ul style="list-style-type: none"> <li>□ in universal enclosure</li> <li>□ on horizontal rail</li> </ul> </li> <li>■ Height: 178 mm (7.01 in)</li> <li>■ Not compatible with Vigi iC60 and auxiliaries</li> <li>■ Can be locked by padlock of (dia. 6 mm / 0.24 in), not supplied with the device</li> </ul> | <p><b>Used to padlock a breaker in open or closed position</b></p> <ul style="list-style-type: none"> <li>■ Padlock diameter: 3 to 6 mm (0.12 to 0.24 in)</li> <li>■ Sealable (max. diameter: 1.2 mm / 0.05 in)</li> <li>■ Locking in ON position does not prevent tripping of the breaker in the event of faults</li> <li>■ Suitable for IEC/EN 60947-2 compliant disconnection</li> </ul> | <p><b>Can be used to padlock a breaker in open position</b></p> <ul style="list-style-type: none"> <li>■ Attached directly to the circuit breaker, it cannot be lost</li> <li>■ Padlock diameter: 6 mm (0.24 in)</li> </ul> |          |                    |
| <b>Catalog numbers</b> | A9A27005   | A9A27006   | A9A27008   | GVAPL01   | A9A27003 (1 per pole)   | A9A26970 | A9A26380           |
|                        | Operating sub-assembly   |  |  |   |   |          | Left-hand mounting |
|                        | +  | +  |  |   |   |          |                    |
|                        | Black handle   | Red handle   | No handle  |   |   |          |                    |
| <b>Set of</b>          | 1  | 1  | 1  | 1   | 1   | 10       | 1                  |
| <b>Suitability</b>     |  |  |  |   |   |          |                    |
| <b>iID</b>             |  |  |  |   | ■ ≤ 63 A  | ■        | ■                  |
| <b>ARA+iID</b>         | -  |  |  |   | -   | ■        | -                  |

| Security               |  |  |  |   |
|------------------------|--|--|--|---|
| Accessories            | Screw shield   | Terminal shield  | Inter-pole barrier   | Spacer  |
|                        |  <p>PB104488-14</p>   |  <p>PB104503-35</p>   |  <p>PB104484-30</p> |  <p>PB104483-35</p>  |
| Function               | <p><b>Prevents any contact with the connecting screws</b></p> <ul style="list-style-type: none"> <li>Upgrades degree of protection to IP20D</li> <li>Sealable, max. diameter 1.2 mm (0.05 in)</li> </ul> | <p><b>Prevents any contact with the terminals</b></p> <ul style="list-style-type: none"> <li>Upgrades degree of protection to IP20D</li> <li>Sealable, max. diameter 1.2 mm (0.05 in)</li> <li>Set of two, for power supply and output terminals</li> <li>For 3 poles: <b>A9A26975 + A9A26976</b></li> <li>For 4 poles: 2 X <b>A9A26976</b></li> </ul> | <p><b>Enhances insulation between connections: cables, terminals, lugs, etc</b></p>                  | <ul style="list-style-type: none"> <li>Used to:           <ul style="list-style-type: none"> <li>complete rows</li> <li>separate devices.</li> </ul> </li> <li>Width: 1 x 9 mm (0.35 in) module</li> <li>Allows cable routing from one row to another, (above and below), up to 6 mm<sup>2</sup></li> </ul> |
| <b>Catalog numbers</b> | <b>A9A26981</b>  | <b>A9A26976</b>  | <b>A9A27001</b>  | <b>A9A27062</b>   |
| <b>Set of</b>          | <b>20 x 4 poles (splittable)</b>   | <b>2 x 2 poles</b>   | <b>10</b>  | <b>5</b>  |
| <b>Suitability</b>     |  |  |  |   |
| iID                    | ■  | ■  | ■  | ■   |
| ARA+iID                | ■  | ■  | ■  | ■   |

| Connection               |   |   |  |
|--------------------------|---|---|--|
| Accessories              | Multi-cable terminal  | 50 mm <sup>2</sup> Al terminal  | Screw-on connection for ring terminal  |
|                          |    |  |                         |
| <b>Function</b>          |   |   |  |
|                          | <b>For 3 copper cables:</b> <ul style="list-style-type: none"> <li>■ Rigid up to 16 mm<sup>2</sup></li> <li>■ Flexible up to 10 mm<sup>2</sup></li> </ul> | <b>For aluminium cables from 16 to 50 mm<sup>2</sup></b>                          | <b>For lug tipped cables, front or rear mounting</b><br>To be used only with inter-pole barrier (A9A27001) |
|                          |    |  |                         |
| <b>Catalog numbers</b>   | <b>19091</b>  | <b>19096</b>  | <b>27060</b>   |
| <b>Set of</b>            | <b>4</b>  | <b>3</b>  | <b>1</b>   |
| <b>Suitability</b>       |   |   |  |
| <b>iID</b>               | ■   | ■   | ■  |
| <b>Tightening torque</b> | 2 N.m   | 10 N.m  | 2 N.m  |
| <b>Length stripping</b>  | 11 mm (0.43 in)   | 13 mm (0.51 in)   | –  |
| <b>Tools to use</b>      | Dia. 5 mm (0.2 in) or PZ2   | Hc 1/5" or 5 mm (0.2 in)  | Dia. 5 mm (0.2 in)   |

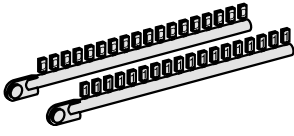
| Marking                                   |   |   |   |
|---|---|---|---|
| Accessories                               | Clip-on terminal markers  |   |   |
|   |  |   |   |
| <b>Used for connection identification</b> |   |   |   |
| <b>Catalog numbers</b>                    | 0: AB1-R0<br>1: AB1-R1<br>2: AB1-R2<br>3: AB1-R3<br>4: AB1-R4                       | 5: AB1-R5<br>6: AB1-R6<br>7: AB1-R7<br>8: AB1-R8<br>9: AB1-R9   | A: AB1-GA<br>B: AB1-GB<br>C: AB1-GC<br>D: AB1-GD<br>E: AB1-GE<br>F: AB1-GF<br>G: AB1-GG<br>H: AB1-GH<br>I: AB1-GI |
|   |   | J: AB1-GJ<br>K: AB1-GK<br>L: AB1-GL<br>M: AB1-GM<br>N: AB1-GN<br>O: AB1-GO<br>P: AB1-GP<br>Q: AB1-GQ<br>R: AB1-GR | S: AB1-GS<br>T: AB1-GT<br>U: AB1-GU<br>V: AB1-GV<br>W: AB1-GW<br>X: AB1-GX<br>Y: AB1-GY<br>Z: AB1-GZ              |
|   |   |   | +: AB1-R12<br>-: AB1-R13<br>Blank: AB1-RV   |
| <b>Set of</b>                             | <b>250</b>  |   |   |

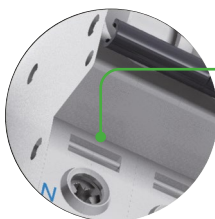

■ 4 markers max. per zone



Dimensions (mm / inches)

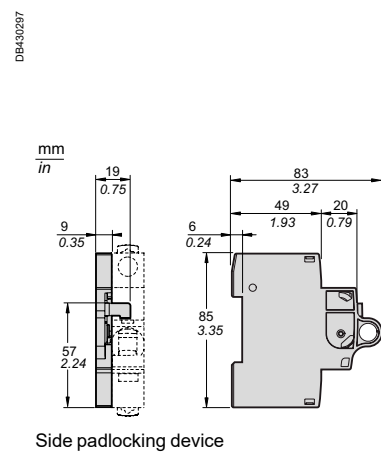
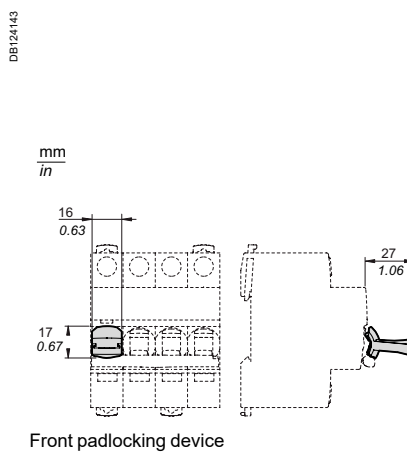
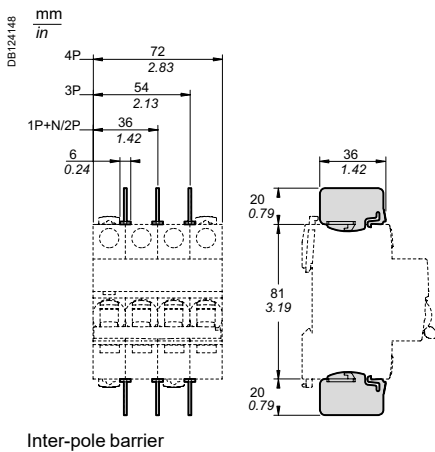
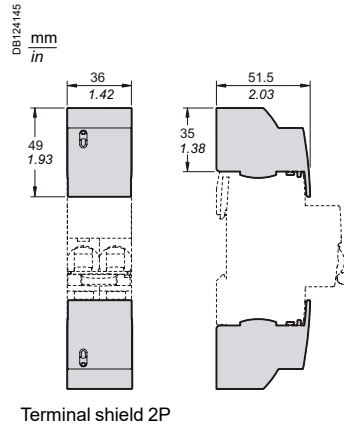
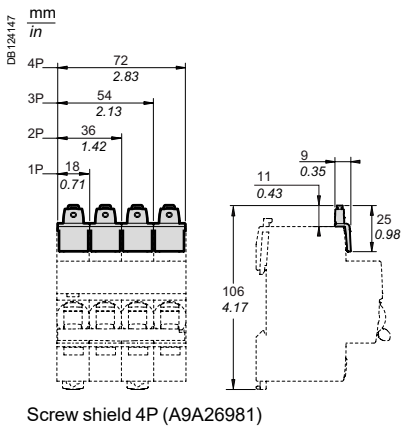
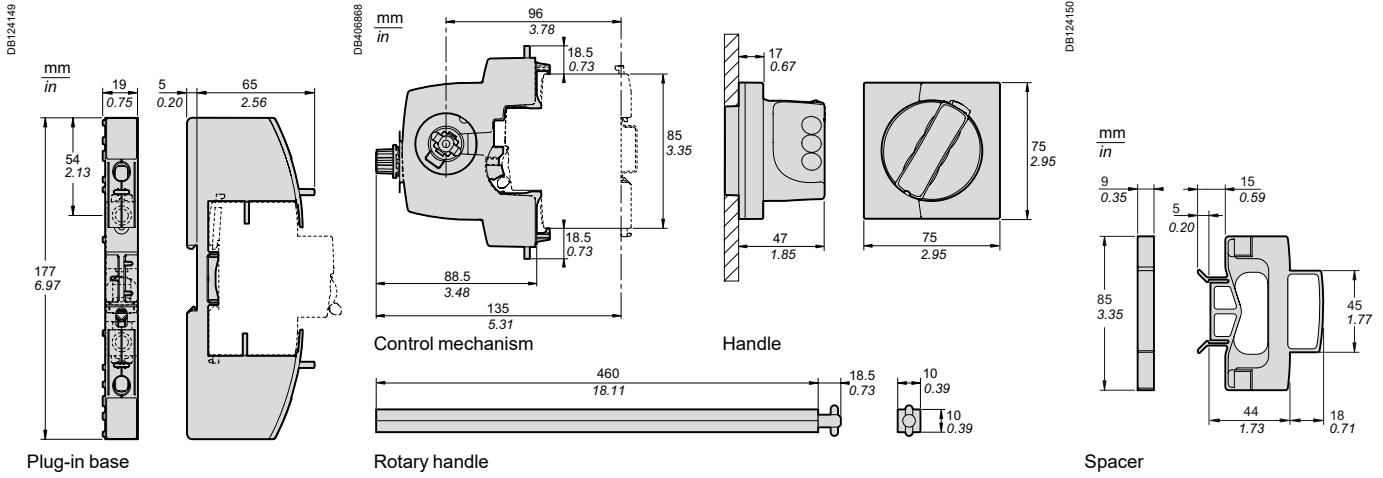

## Rotary handle installation

### Dimensions (mm / inches)

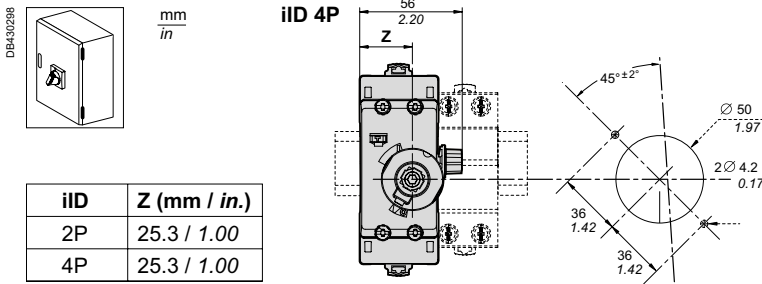

| iID | Z (mm / in.) |
|-----|--------------|
| 2P  | 25.3 / 1.00  |
| 4P  | 25.3 / 1.00  |

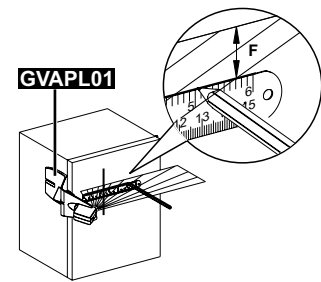
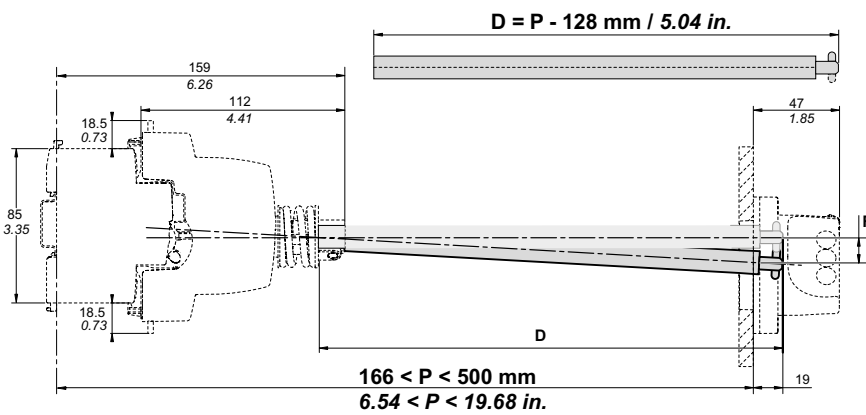

| P (mm / in.) | F (mm / in.) |
|--------------|--------------|
| 300 / 11.81  | 5 / 0.20     |
| 500 / 19.68  | 11 / 0.43    |

Rotary handle: front mounted control

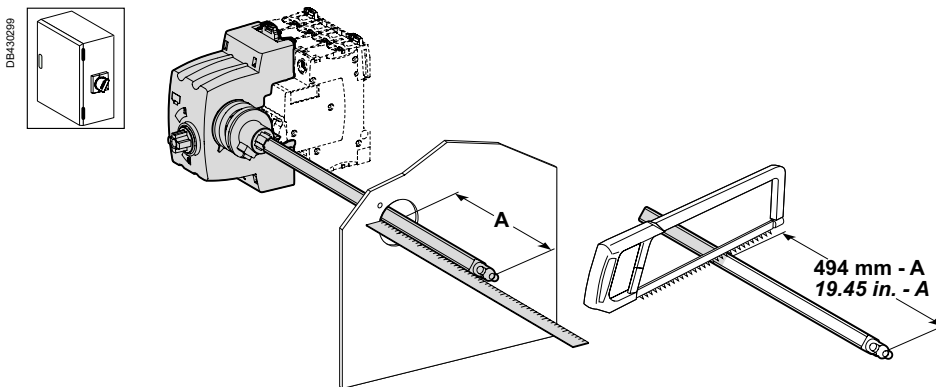

| iID | X (mm / in.) | Y (mm / in.) |
|-----|--------------|--------------|
| 2P  | 44.5 / 1.75  | 76.8 / 3.02  |
| 4P  | 44.5 / 1.75  | 76.8 / 3.02  |

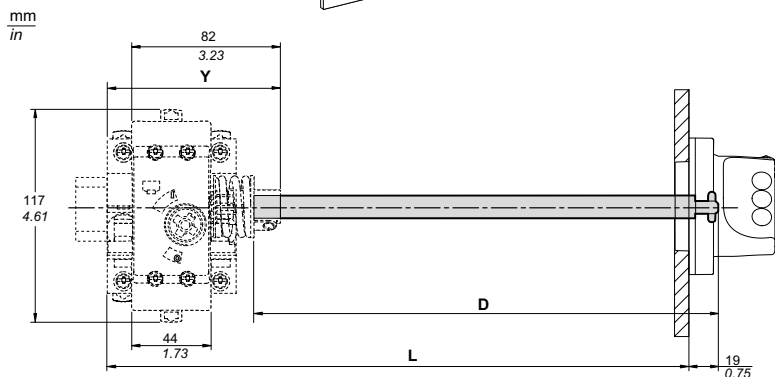

Rotary handle: side mounted control



These comb busbars are aimed to be used only with C60BP circuit breakers.

They perform distribution and subdistribution of the electric power supply and allow rapid assembly and disassembly of equipment.

### Comb busbars

#### Connection accessories

#### Function

- The comb busbars make it easier to install C60BP UL 489 circuit breakers
- They must not be cut

#### Use

- Power supply by insulated connector

#### Standard comb busbars



|                                |                 |                 |                 |                 |                 |                 |
|--------------------------------|-----------------|-----------------|-----------------|-----------------|-----------------|-----------------|
| Number of poles                | 1P              |                 | 2P              |                 | 3P              |                 |
| Catalog numbers                | <b>M9XUP106</b> | <b>M9XUP112</b> | <b>M9XUP206</b> | <b>M9XUP212</b> | <b>M9XUP306</b> | <b>M9XUP312</b> |
| Number of 18 mm (0.71 in) mod. | 6               | 12              | 6               | 12              | 6               | 12              |
| Set of                         | 1               |                 | 1               |                 | 1               |                 |

#### Cuttable comb busbars

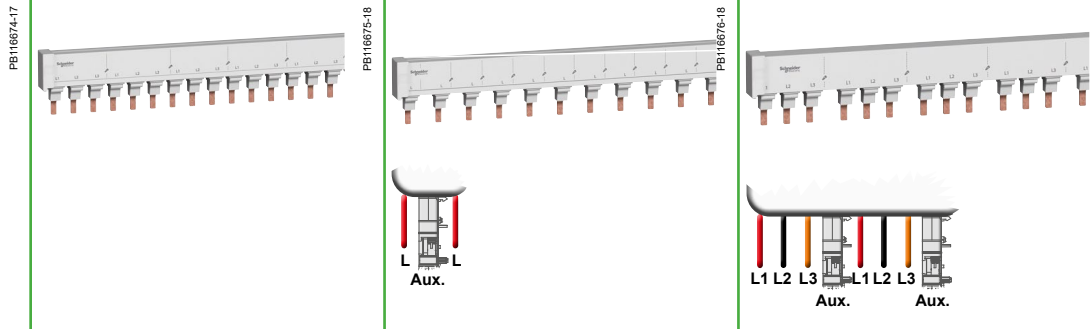

With spare spaces of 9 mm (0.35 in) for 9 mm (0.35 in) electrical auxiliary

|                                |                 |                 |                 |                 |                 |
|--------------------------------|-----------------|-----------------|-----------------|-----------------|-----------------|
| Number of poles                | 1P              | 2P              | 3P              | 1P+Aux          | 3P+Aux          |
| Catalog numbers                | <b>M9XCP157</b> | <b>M9XCP256</b> | <b>M9XCP357</b> | <b>M9XCA137</b> | <b>M9XCA348</b> |
| Number of 18 mm (0.71 in) mod. | 57              | 56              | 57              | 37              | 48              |
| Set of                         | 1               | 1               | 1               | 1               | 1               |





#### Technical specifications

|  |  |
|--|--|
| Acceptable current at 40°C (104 °F) (Ie) | Standard comb busbars: 115 A<br>Cuttable comb busbars: 80 A                          |
| Resistance to short-circuit currents     | Compatible with the breaking capacity of Schneider Electric modular circuit breakers |
| Voltage rating (Ue)                      | 480Y/277 V   |
| Insulation voltage (Ui)                  | 1000 V AC  |
| Pollution degree                         | 3  |
| Fire resistance                          | Self-extinguishability 960°C (1760 °F) 30 secondes                                   |
| Colour                                   | RAL 9001   |
| Standards                                | UL489 and UL508  |

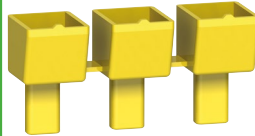

These comb busbars are aimed to be used only with C60BP circuit breakers.

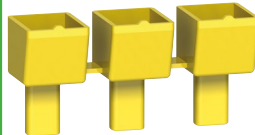

They perform distribution and subdistribution of the electric power supply and allow rapid assembly and disassembly of equipment.

| Accessories                              |   |  |   |
|--|---|--|---|
| Connection accessories                   | Insulated connectors  | Tooth covers   | End-piece   |
| <b>Function</b>                          |   |  |   |
|  | <ul style="list-style-type: none"> <li>Comb busbar power supply</li> <li>Vertical incoming feeder</li> </ul>  | <ul style="list-style-type: none"> <li>Insulation of teeth remaining free</li> </ul> | <ul style="list-style-type: none"> <li>Insulation of end of comb busbar</li> </ul>    |
| <b>Use</b>                               |   |  |   |
|  | <ul style="list-style-type: none"> <li>Rigid and flexible copper cable: 6 to 35 mm<sup>2</sup> (AWG #10 to #2)</li> <li>Tightening torque: 3.5 N.m (31 lb.in)</li> <li>Tool to use: hexagonal key Sw4 (4mm).</li> </ul> |  |   |
| <b>Standard comb busbars</b>             |   |  |   |
|  |   |    |   |
| Number of poles                          | All   | All  | -   |
| Catalog numbers                          | <b>M9XUPC04</b>   | <b>M9XUTC15</b>  | -   |
| Number of 18 mm (0.71 in) mod.           | -   | -  | -   |
| Set of                                   | <b>4</b>  | <b>5 x 3</b>   | -   |
| <b>Cuttable comb busbars</b>             |   |  |   |
|  |    |  |  |
| Number of poles                          | All   | All  | All   |
| Catalog numbers                          | <b>M9XCPC04</b>   | <b>M9XCTC15</b>  | <b>M9XCEC10</b>   |
| Number of 18 mm (0.71 in) mod.           | -   | -  | -   |
| Set of                                   | <b>4</b>  | <b>5 x 3</b>   | <b>10</b>   |
| <b>Technical specifications</b>          |   |  |   |
| Acceptable current at 40°C (104 °F) (Ie) | -   | -  | -   |
| Resistance to short-circuit currents     | Compatible with the breaking capacity of Schneider Electric modular circuit breakers  | Compatible with the breaking capacity of Schneider Electric modular circuit breakers | Compatible with the breaking capacity of Schneider Electric modular circuit breakers  |
| Voltage rating (Ue)                      | 480Y/277 V  | 480Y/277 V   | 480Y/277 V  |
| Insulation voltage (Ui)                  | 1000 V AC   | 1000 V AC  | 1000 V AC   |
| Pollution degree                         | 3   | 3  | 3   |
| Fire resistance                          | Self-extinguishability 960°C (1760 °F) 30 secondes  | Self-extinguishability 960°C (1760 °F) 30 secondes                                   | Self-extinguishability 960°C (1760 °F) 30 secondes                                    |
| Colour                                   | RAL 7035  | RAL 1021   | RAL 7035  |
| Standards                                | UL486E  | -  | -   |

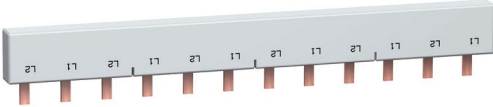

The comb busbars are used only for C60sP circuit breakers UL 1077 supplementary protection in conformity with standards:  
UL 1077 / CSA C22.2 No. 235 / IEC 60947-2 / GB 14048-2.

They perform distribution and subdistribution of the electric power supply and allow rapid assembly and disassembly of equipment.

| Connection accessories | Comb busbars  | Accessory   |
|------------------------|---|---|
|                        | <b>Comb busbar</b><br> | <b>Tooth cover end-piece</b><br> |

| Function                          | Comb busbars  |                      |                      | Accessory  |
|-----------------------------------|---|----------------------|----------------------|--|
|                                   | <ul style="list-style-type: none"> <li>The comb busbars make it easier to install Schneider Electric circuit breakers UL 1077 supplementary protection</li> <li>Power supply directly in the cage of the circuit breaker</li> </ul> |                      |                      | <ul style="list-style-type: none"> <li>The Tooth Caps are insulated protectors which may be slipped onto the unused teeth of the comb busbar</li> <li>They come in strips with 1-pole spacing, but can be snapped apart to be used individually</li> </ul> |
| Number of poles                   | 1P  | 2P                   | 3P                   | All  |
| Voltage rating (Ue)               | 480Y/277 V AC   | 480Y/277 V AC        | 480Y/277 V AC        | -  |
| Catalog numbers                   | 10285   | 10286                | 10287                | 60488  |
| Number of 18 mm (0.71 in) modules | 12 (216 mm / 8.5 in)  | 12 (216 mm / 8.5 in) | 12 (216 mm / 8.5 in) | -  |
| Set of                            | 1   | 1                    | 1                    | 20   |

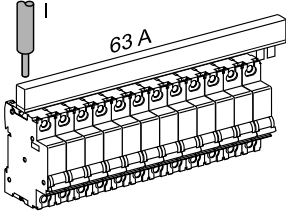
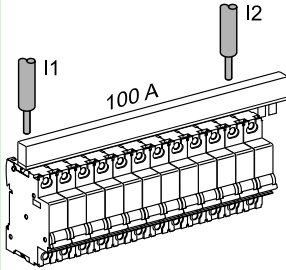
| Technical specifications                 | Comb busbars  |  | Accessory |
|--|---|--|-----------|
| Insulation voltage (Ui)                  | 690 V   |  | -         |
| Impulse withstand voltage (Uimp)         | 12 kV under 240 V<br>5 kV under 480Y/277 V or 277 V   |  | -         |
| Acceptable current at 40°C (104 °F) (Ie) | 63 A with 1 central power supply point  | 100 A with 2 power supply points   | -         |
|  |    |  |           |
|  | <ul style="list-style-type: none"> <li>Power supply via cable directly in the cage of the device:                             <ul style="list-style-type: none"> <li>cross section maxi: 3 AWG (25 mm<sup>2</sup>)</li> <li>cross section mini: 10 AWG (5.27 mm<sup>2</sup>)</li> </ul> </li> </ul> |  |           |
| Resistance to short-circuit currents     | Compatible with the breaking capacity of C60sP Schneider Electric circuit breakers UL 1077 supplementary protection   |  |           |
| Pollution degree                         | 3   |  |           |
| Fire resistance                          | Self-extinguishability 960°C (1760 °F) 30 secondes  |  |           |
| Colour                                   | RAL 7035  |  | RAL 1021  |
| Standards                                | UL 1077   |  | -         |

### Dimensions (mm / inches)

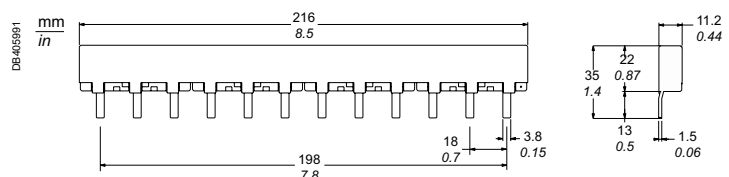





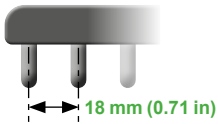

IEC

IEC 60947-7-1, IEC 61439-2





| C60                           | 18 mm (0.71 in) poles, cuttable   |  |   |   |   |
|-------------------------------|---|--|---|---|---|
| Number of poles               | 1P  | 2P   | 3P  | 4P  | 3 (N+P)   |
|                               | <br>L1 | <br>L1 L2 | <br>L1 L2 L3 | <br>N L1 L2 L3 | <br>N L1 NL2 NL3 |
| Type                          | L1...   | L1L2...  | L1L2L3...   | NL1L2L3...  | NL1NL2NL3...  |
| Set of                        | 1   | 1  | 1   | 1   | 1   |
| <b>Catalog numbers</b>        |   |  |   |   |   |
| 6 modules of 18 mm (0.71 in)  | A9XPH106  | -  | A9XPH306  | -   | -   |
| 12 modules of 18 mm (0.71 in) | A9XPH112  | A9XPH212   | A9XPH312  | A9XPH412  | A9XPH512  |
| 18 modules of 18 mm (0.71 in) | -   | -  | -   | -   | A9XPH518  |
| 24 modules of 18 mm (0.71 in) | A9XPH124  | A9XPH224   | A9XPH324  | A9XPH424  | A9XPH524  |
| 57 modules of 18 mm (0.71 in) | A9XPH157  | A9XPH257   | A9XPH357  | A9XPH457  | A9XPH557  |

### Technical data

|  |  |
|--|--|
| Operating current (Ie)<br>at 40°C (104 °F) | 100 A  |
| Short-circuit current (Isc)                | Compatible with the breaking capacity of Schneider Electric circuit breakers |
| Rated insulation voltage (Ui)              | 500 V AC   |
| Operating voltage (Ue)                     | 415 V AC   |
| Pollution degree                           | 3  |
| Fire resistance IEC 695-2-1                | Self-extinguishing at 960°C (1760 °F) 30 secondes                            |
| Color                                      | RAL 7016 (anthracite grey)   |

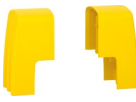
### Accessories

| Number of poles        | 1P  | 2P              | 3P              | 4P              | -  | -   |
|------------------------|---|-----------------|-----------------|-----------------|--|---|
|                        |  |                 |                 |                 |   |  |
|                        | <b>End-pieces</b>   |                 |                 |                 | <b>Tooth covers</b>  |   |
|                        | Lateral end-pieces providing IP20 protection  |                 |                 |                 | Insulate teeth that have been left free  |   |
|                        |   |                 |                 |                 | <b>Connectors</b>  |   |
|                        |   |                 |                 |                 | <b>Monoconnect</b>   |   |
|                        |   |                 |                 |                 | Comb busbar power supply. Horizontal in comer on each side. For 35 mm <sup>2</sup> cable. Tightening torque 4 N.m (35.4 lb.in) |   |
| Set of                 | 10  | 10              | 10              | 10              | 20   | 4   |
| <b>Catalog numbers</b> | <b>A9XPE110</b>   | <b>A9XPE210</b> | <b>A9XPE310</b> | <b>A9XPE410</b> | <b>A9XPT920</b>  | <b>A9XPCM04</b>   |



| Cuttable comb busbars, 18 mm (0.71 in) modules, with 9 mm (0.35 in) auxiliary |            |              |               |                    |                    |
|---|------------|--------------|---------------|--------------------|--------------------|
| Aux+1P  | Aux+2P     | Aux+3P       | Aux+4P        | 3 (Aux+1P)         | 3 (Aux+N+1P)       |
|   |            |              |               |                    |                    |
| AuxL1...  | AuxL1L2... | AuxL1L2L3... | AuxNL1L2L3... | AuxL1AuxL2AuxL3... | AuxL1AuxL2AuxL3... |
| 1   | 1          | 1            | 1             | 1                  | 1                  |
| -   | -          | -            | -             | -                  | -                  |
| -   | -          | -            | -             | -                  | -                  |
| -   | -          | -            | -             | -                  | -                  |
| -   | -          | -            | -             | -                  | -                  |
| A9XAH157  | A9XAH257   | A9XAH357     | A9XAH457      | A9XAH657           | A9XAH557           |

IEC

IEC 60439-1

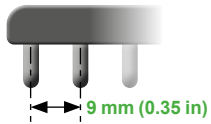

| N40N, N40 Vigi                                  | 9 mm (0.35 in) poles, cuttable |       |       |       |                    |       |       |       |
|---|--------------------------------|-------|-------|-------|--------------------|-------|-------|-------|
|   | 1P + N                         |       |       |       | 3P + N             |       |       |       |
| Number of poles                                 | <br>N L                        |       |       |       | <br>N L1 N L2 N L3 |       |       |       |
| Number of 18 mm (0.71 in) modules               | 12                             | 18    | 24    | 48    | 12                 | 18    | 24    | 48    |
| Supplied accessories                            |                                |       |       |       |                    |       |       |       |
| Tooth covers (for 3 modules of 18 mm / 0.71 in) | 1                              | 1     | 2     | -     | 1                  | 1     | 2     | -     |
| End-pieces                                      | 4                              | 4     | 4     | -     | 4                  | 4     | 4     | -     |
| Catalog numbers                                 | 21501                          | 19512 | 21503 | 21089 | 21505              | 19516 | 21507 | 21093 |

| Technical data                          |  |  |
|---|--|--|
| Operating current at 40°C (104 °F) (Ie) |  | 80 A   |
| Short-circuit current (Isc)             |  | Compatible with the breaking capacity of Schneider Electric circuit breakers |
| Rated insulation voltage (Ui)           |  | 440 V AC   |
| Operating voltage (Ue)                  |  | 230 V AC (P + N) - 400 V AC (3P + N)   |
| Degree of protection                    |  | IP20   |
| Pollution degree                        |  | 3  |
| Fire resistance IEC 695-2-1             |  | Self-extinguishing at 960°C (1760 °F) 30 secondes                            |
| Color                                   |  | RAL 7035   |

| Accessories     |            |        |  |   |
|-----------------|------------|--------|--|---|
| Number of poles | 1P + N     |        | 3P + N   |   |
|                 |            |        |  |   |
|                 | End-pieces |        | Tooth covers (3 x 18 mm / 3 x 0.71 in modules) | Tooth covers (1 x 18 mm / 1 x 0.71 in module) |
| Set of          | 40         |        | 12   | 10  |
| Catalog numbers | 021094     | 021095 | 021096   | 010405  |
|                 |            |        |  | <br>Connectors (grey)                         |
|                 |            |        |  | 4   |
|                 |            |        |  | 021098  |

IEC

IEC 60439-1

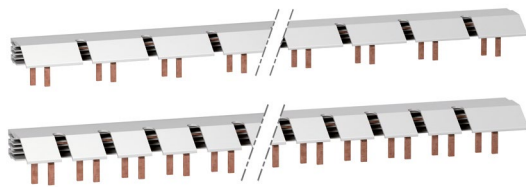
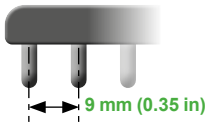

### Comb busbar for 1P+N circuit breaker with 9 mm (0.35 in) auxiliary OF, SD

| N40N, N40 Vigi                    | 9 mm (0.35 in) poles, cuttable |                              |                      |                              |
|-----------------------------------|--------------------------------|------------------------------|----------------------|------------------------------|
| Number of poles                   | Aux., N, L                     | Aux. NL1, Aux. NL2, Aux. NL3 | Aux., N, L1          | Aux. NL1, Aux. NL2, Aux. NL3 |
|                                   |                                |                              |                      |                              |
| Number of 18 mm (0.71 in) modules | N40N comb busbar               |                              | N40 Vigi comb busbar |                              |
| Catalog numbers                   | A9N21035                       | A9N21036                     | A9N21037             | A9N21038                     |

### Technical data

|   |  |
|---|--|
| Operating current at 40°C (104 °F) (Ie) | 63 A   |
| Short-circuit current (Isc)             | Compatible with the breaking capacity of Schneider Electric circuit breakers |
| Rated insulation voltage (Ui)           | 500 V AC   |
| Operating voltage (Ue)                  | 230 V AC (P + N) - 400 V AC (3P + N)   |
| Degree of protection                    | IP20   |
| Pollution degree                        | 3  |
| Fire resistance IEC 695-2-1             | Self-extinguishing at 960°C (1760 °F) 30 secondes                            |
| Color                                   | RAL 7035   |

4

### Accessories

| Number of poles | Aux., N, L | Aux. NL1, Aux. NL2, Aux. NL3 |                   |                           |   |
|-----------------|------------|------------------------------|-------------------|---------------------------|---|
|                 |            |                              |                   |                           |   |
|                 | End-pieces |                              | Connectors (grey) | Neutral connectors (bleu) | Tooth covers (1 x 18 mm / 1 x 0.71 in module) |
| Set of          | 20         |                              | 10                | 10                        | 10  |
| Catalog numbers | A9N21039   | A9N21040                     | A9N21041          | A9N21042                  | A9N21050                                      |



### IEC/EN 60947-7-1, IEC/EN 61439-1 & 2

As per the above standards:

### Description

- Single-pole or four-pole distribution block that can be installed on a standard DIN rail or on a mounting plate.
- Compatible with Prisma G and P, Pragma, Mini Pragma and Resbo series switchboards.
- Incomers and feeders are connected to screw terminals that accept rigid or flexible cables with ferrule.
- Optional: additional neutral terminal strip for four-pole distribution block.

### Advantages

- Simplified power supply for main incomers.
- Easy phase balancing.
- Easy, effortless cabling due to excellent accessibility.
- Visible cabling.
- Insulation between phases.
- The single-pole distribution blocks are adjacent and bridgeable via the second incoming hole for parallel connection.

### Screw distribution blocks

| Number of poles  | 1P   |  |  | 4P  |
|--|--|--|--|---|
|  |  |  |  |   |
| Rated operational current  | 125 A                                      | 160 A                                      | 250 A                                      | 100 A                                       |
| Total connections capacity   | 10   | 13   | 14   | 4 x 7                                       |
| <b>Terminal capacity</b>   |  |  |  |   |
| Diameter   | 2 x Ø 9.5 mm (0.37 in)                     | 2 x Ø 12 mm (0.47 in)                      | 1 x Ø 15.3 mm                              | 2 x Ø 7.5 mm (0.29 in)                      |
|  | 2 x Ø 7.5 mm (0.29 in)                     | 3 x Ø 7.5 mm (0.29 in)                     | 1 x Ø 10 mm (0.39 in)                      | 5 x Ø 5.5 mm (0.22 in)                      |
|  | 6 x Ø 5.8 mm (0.23 in)                     | 8 x Ø 5.8 mm (0.23 in)                     | 4 x Ø 6 mm (0.24 in)                       | -   |
|  | -  | -  | 8 x Ø 7.5 mm (0.29 in)                     | -   |
| Rated peak withstand current (I <sub>pk</sub> )                          | 25 kA                                      | 36 kA                                      | 60 kA                                      | 14 kA                                       |
|  | -  | -  | -  | 24 kA                                       |
| Rated short-time withstand current (I <sub>cw</sub> ) (IEC/EN 60947-7-1) | 4.2 kA rms/1 s                             | 8.4 kA rms/1 s                             | 14.4 kA rms/1 s                            | 3 kA rms/1 s                                |
| Width (nb of 9 mm / 0.35 in pitches)                                     | 3  | 4  | 5  | 8   |
| Dimension (H x W x D)  | 85 x 27 x 50.5 mm<br>3.35 x 1.06 x 1.99 in | 85 x 36 x 50.5 mm<br>3.35 x 1.42 x 1.99 in | 85 x 45 x 50.5 mm<br>3.35 x 1.77 x 1.99 in | 100 x 71 x 50.5 mm<br>3.94 x 2.79 x 1.99 in |
| Weight   | 125 g (4.41 oz)                            | 163 g (5.75 oz)                            | 239 g (8.43 oz)                            | 210 g (7.41 oz)                             |
| Neutral terminal strip (optional)  | -  | -  | -  | LGYN1007                                    |
| References   | <b>LGY112510</b>                           | <b>LGY116013</b>                           | <b>LGY125014</b>                           | <b>LGY410028</b>                            |



DS406005\_1.eps



On LGY412560 and LGY416048 references.  
Input cabling facilitated by side terminals.

### Technical data

#### Common characteristics

##### To IEC/EN 60947-7-1 and IEC/EN 61439-1 & 2

|  |  |
|--|--|
| Rated insulation voltage (Ui)                          | 500 V AC   |
| Rated operational voltage (Ue)                         | 230 V AC (Ph/N)<br>440 V AC (Ph/Ph)  |
| Rated impulse withstand voltage (Uimp)                 | 8 kV   |
| Rated conditional short-circuit current of an assembly | Up to the breaking capacity of Schneider Electric feeder circuit breakers, even in cascading configuration |
| Network frequency                                      | 50/60 Hz   |
| Pollution degree                                       | 3  |
| Overvoltage category                                   | III  |

#### Additional technical characteristics

|                                       |                                    |
|---------------------------------------|------------------------------------|
| Reference temperature                 | 40 °C (104 °F)                     |
| Operating temperature                 | -25 °C to 55 °C (-13 °F to 131 °F) |
| Dielectric withstand (IEC/EN 60947-1) | 2500 V AC                          |

|  |  |  | Neutral terminal strip                   |   |  |
|--|--|--|--|---|--|
| 125 A  | 160 A  | 100 A  | 125 A                                    | 15  |  |
| 4 x 12                                       | 4 x 15                                       | 4 x 12                                       | 7  | 12  | 15                                       |
| 1 x Ø 9 mm (0.35 in)                         | 1 x Ø 9.5 mm (0.37 in)                       | 1 x Ø 12 mm (0.47 in)                        | 2 x Ø 7.5 mm (0.29 in)                   | 1 x Ø 9 mm (0.35 in)                      | 1 x Ø 9.5 mm (0.37 in)                   |
| 7 x Ø 7.5 mm (0.29 in)                       | 3 x Ø 8.5 mm (0.33 in)                       | 3 x Ø 9 mm (0.35 in)                         | 5 x Ø 5.5 mm (0.22 in)                   | 7 x Ø 7.5 mm (0.29 in)                    | 3 x Ø 8.5 mm (0.33 in)                   |
| 4 x Ø 6.5 mm (0.26 in)                       | 11 x Ø 6.5 mm (0.26 in)                      | 8 x Ø 7.5 mm (0.29 in)                       | -  | 4 x Ø 6.5 mm (0.26 in)                    | 11 x Ø 6.5 mm (0.26 in)                  |
| -  | -  | -  | -  | -   | -  |
| 18 kA  | 18 kA  | 22 kA  | -  | -   | -  |
| 26 kA  | 28 kA  | 36 kA  | -  | -   | -  |
| 4.2 kA rms/1 s                               | 4.2 kA rms/1 s                               | 8.4 kA rms/1 s                               | -  | -   | -  |
| 14   | 20   | 18   | 7  | 14  | 17                                       |
| 100 x 126 x 50.5 mm<br>3.94 x 4.96 x 1.99 in | 100 x 162 x 50.5 mm<br>3.94 x 6.38 x 1.99 in | 100 x 174 x 50.5 mm<br>3.94 x 6.85 x 1.99 in | 20 x 70 x 35 mm<br>0.79 x 2.76 x 1.38 in | 20 x 125 x 35 mm<br>0.79 x 4.92 x 1.38 in | 20 x 155 x 35 mm<br>0.79 x 6.1 x 1.38 in |
| 390 g (13.76 oz)                             | 559 g (19.72 oz)                             | 567 g (20 oz)                                | 63 g (2.22 oz)                           | 111 g (3.91 oz)                           | 149 g (5.26 oz)                          |
| LGYN12512                                    | LGYN12515                                    | LGYN12512                                    | -  | -   | -  |
| <b>LGY412548</b>                             | <b>LGY412560</b>                             | <b>LGY416048</b>                             | <b>LGYN1007</b>                          | <b>LGYN12512</b>                          | <b>LGYN12515</b>                         |

### Terminal technical data

| Type                                   | PZ2 screw                                     |   |   |   |   |   |   |   |
|--|---|---|---|---|---|---|---|---|
| Diameter                               | Ø 5.5 mm (0.22 in)                            | Ø 5.8 mm (0.23 in)                            | Ø 6 mm (0.24 in)                              | Ø 6.5 mm (0.26 in)                            | Ø 7.5 mm (0.3 in)                             | Ø 8.5 mm (0.33 in)                          | Ø 9 mm (0.35 in)                            | Ø 9.5 mm (0.37 in)                          |
| Section rigid cable                    | 1.5 to 16 mm <sup>2</sup> (AWG #16 to AWG #6) | 1.5 to 16 mm <sup>2</sup> (AWG #16 to AWG #6) | 1.5 to 16 mm <sup>2</sup> (AWG #16 to AWG #6) | 1.5 to 16 mm <sup>2</sup> (AWG #16 to AWG #6) | 2.5 to 25 mm <sup>2</sup> (AWG #14 to AWG #4) | 6 to 35 mm <sup>2</sup> (AWG #10 to AWG #2) | 10 to 35 mm <sup>2</sup> (AWG #8 to AWG #2) | 10 to 35 mm <sup>2</sup> (AWG #8 to AWG #2) |
| Section flexible cable or with ferrule | 1.5 to 10 mm <sup>2</sup> (AWG #16 to AWG #8) | 1.5 to 10 mm <sup>2</sup> (AWG #16 to AWG #8) | 1.5 to 10 mm <sup>2</sup> (AWG #16 to AWG #8) | 1.5 to 10 mm <sup>2</sup> (AWG #16 to AWG #8) | 1.5 to 16 mm <sup>2</sup> (AWG #16 to AWG #6) | 4 to 25 mm <sup>2</sup> (AWG #12 to AWG #4) | 4 to 25 mm <sup>2</sup> (AWG #12 to AWG #4) | 6 to 35 mm <sup>2</sup> (AWG #10 to AWG #2) |
| Tightening torque                      | 2 N.m (18 lb.in)                              | 2 N.m (18 lb.in)                              | 2 N.m (18 lb.in)                              | 2 N.m (18 lb.in)                              | 2 N.m (18 lb.in)                              | 2 N.m (18 lb.in)                            | 2.5 N.m (22 lb.in)                          | 2.5 N.m (22 lb.in)                          |

| Type                                   | Hc screw                                    |   |   |   |  |
|--|---|---|---|---|--|
| Diameter                               | Ø 9.5 mm (0.37 in)                          | Ø 10 mm (0.39 in)                             | Ø 12 mm (0.47 in)                             | Ø 15.3 mm (0.6 in)  |  |
| Section rigid cable                    | 10 to 35 mm <sup>2</sup> (AWG #8 to AWG #2) | 1.5 to 50 mm <sup>2</sup> (AWG #16 to AWG #1) | 25 to 70 mm <sup>2</sup> (AWG #4 to AWG #2/0) |  | 35 to 120 mm <sup>2</sup> (AWG #2 to AWG #4/0) |
| Section flexible cable or with ferrule | 6 to 35 mm <sup>2</sup> (AWG #10 to AWG #2) | 1.5 to 35 mm <sup>2</sup> (AWG #16 to AWG #2) | 16 to 50 mm <sup>2</sup> (AWG #6 to AWG #1)   | 25 to 95 mm <sup>2</sup> (AWG #4 to AWG #3/0)                                     |  |
| Tightening torque                      | 8 N.m (71 lb.in)                            | 4 N.m (35 lb.in)                              | 1P: 9 N.m (80 lb.in)                          | 4P: 5 N.m (44 lb.in)  | 14 N.m (124 lb.in)                             |

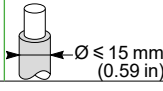
### Dimensions (mm / inches)



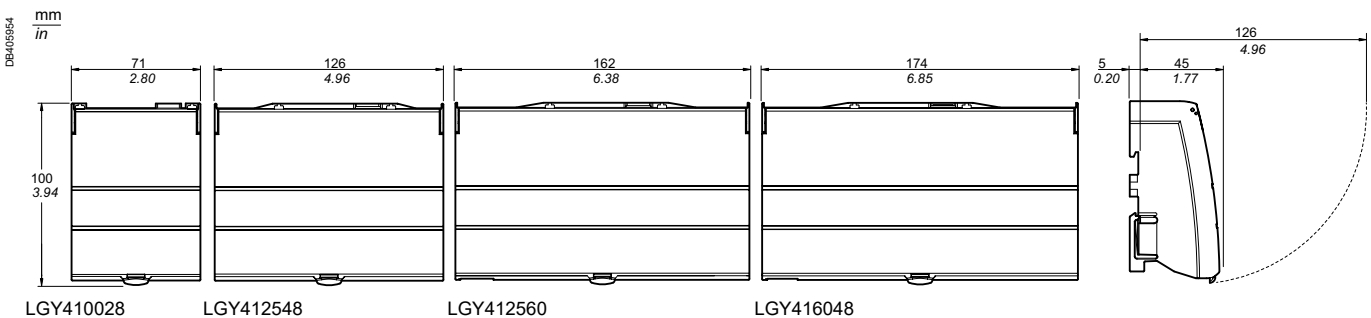
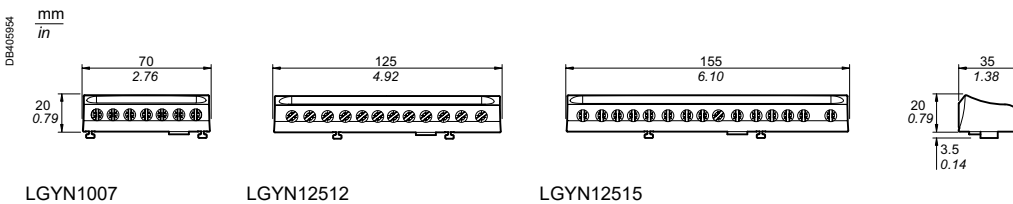
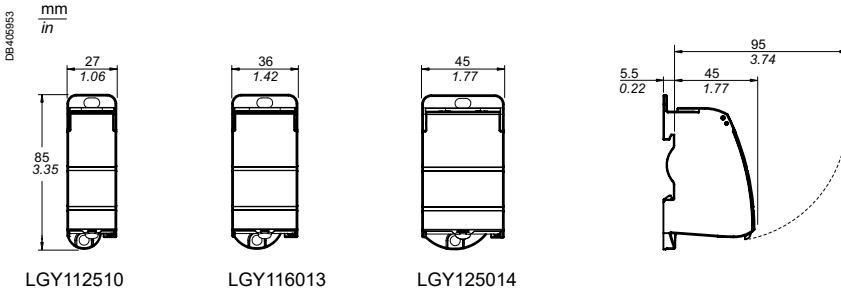



The setup of circuit protective devices depends on the electrical installation standard. Multi9 devices (designed for machinery and equipment manufacturers, integrators, panelbuilders, etc.) are tested in accordance with the UL (Underwriter Laboratories) product standard in order to meet the requirements of the NEC (National Electric Code) installation standard, in force in the United States. To allow the most extensive possible use worldwide, Multi9 "UL" products are also tested to ensure compliance with IEC and CSA standards.

The CE Marking is an administrative formality for free circulation and sale on the territory of the European Union. Made compulsory by a European directive, the CE Marking of products complies with the administrative and legal requirements. Designed for the European supervisory authorities (customs authorities), the "CE Marking" declarations and dossiers are produced under the sole responsibility of the manufacturer and undergo no conformity check by a third-party organization. Only the quality marks, issued and inspected by an independent third-party organization, provide a full guarantee of operation, compatibility and safety in accordance with national and international standards.

**UL 489****Branch circuit protection**

The UL 489 standard applies primarily to the protection of circuits installed, in accordance with the NEC (National Electric Code):

- upstream of a device or a machine (branch circuit protection)
- inside the device or a machine, for certain loads (ventilation, air conditioning, heating, etc.)
- to power loads external to the device (motors, power sockets, etc.).

**UL 1077****Supplementary protection - Internal protection of electrical equipment**

The UL 1077 standard applies to circuit breakers for electrical equipment, in accordance with the NEC. These circuit breakers are considered as components forming part of the equipment but can in no case replace a UL 489 protective device. Their use is limited to the protection of specific loads exclusively inside the machine or equipment. Where the machine or equipment is powered upstream by a control panel, the UL 1077 protection must be combined with a UL 489 protective device in that panel.

**CSA C22.2 No. 5-02****Branch circuit protection**

The requirements of this standard cover circuit breakers that are specifically intended to provide service entrance, feeder and branch circuit protection in accordance with the National Installation Codes.

This standard is close to UL489.

**CSA C22.2 No. 235-04****Supplementary protection - Internal protection of electrical equipment**

This Standard applies to supplementary protectors that are intended for use as components within appliances or other electrical equipment where branch-circuit protection is already provided (or is not required), in accordance with the Rules of the Canadian Electrical Code.

This standard is close to UL1077.

**IEC 60947-2**

The IEC 60947-2 standard is an international product standard concerning circuit breakers; it is used for industrial circuit protection applications. It meets the requirements of the IEC 60364 installation standard.

**GB 14048-2**

The GB 14048-2 standard is close to the IEC 60947-2 standard for installations on Chinese territory.



**Example of use of UL 489 circuit breakers and UL 1077 electrical equipment internal protective devices**

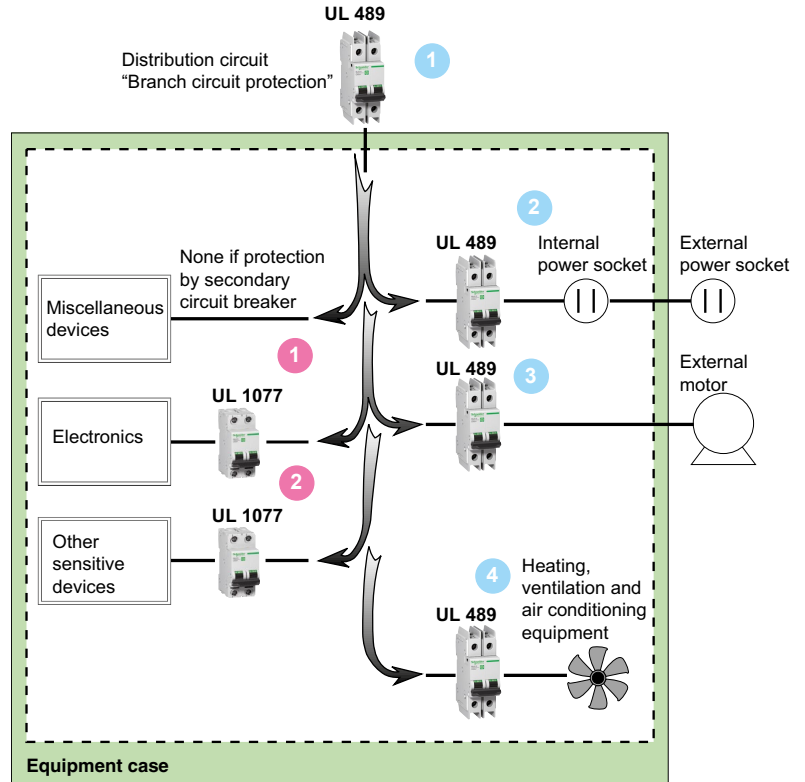

**UL 1077**

**Applications allowing the use of electrical equipment internal protective devices**

**UL 1077 1**

Supplements an existing protective device or provides additional protection inside equipment

**UL 1077 2**

Used for the protection of internal circuits such as:

- Computers and microprocessors
- Telecommunications equipment
- Electronic controllers
- Power supply sources
- Transformers
- Small motors.

**UL 489**

**Applications requiring branch circuit protection**

**UL 489 1**

Equipment incoming end protection.

**UL 489 2**

Power socket circuit protection (internal or external).

**UL 489 3**

Protection of an external circuit (e.g. motor).

**UL 489 4**

Protection of heating, ventilation and air conditioning equipment (HACR/HVAC).



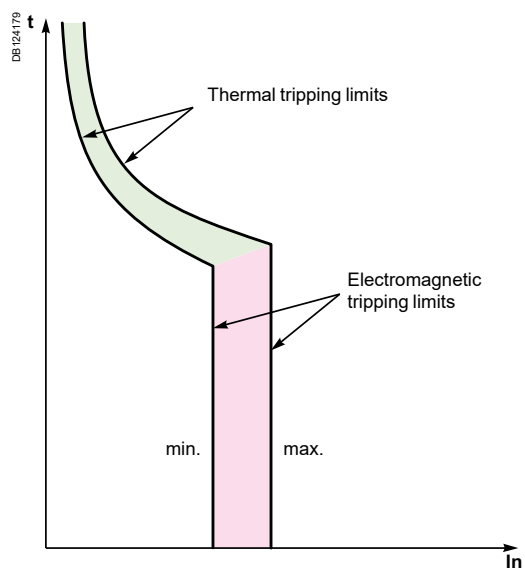

The following curves show the total fault current breaking time, depending on its amperage. For example: based on the curve on "Circuit breakers tripping curves", page 92, a C60 circuit breaker of curve C, 20 A rating, will interrupt a current of 100 A (5 times the rated current  $I_n$ ) in:

- 1 second at least
- 7 seconds at most.

The circuit breakers' tripping curves consist of two parts:

- tripping of overload protection (thermal tripping device): the higher the current, the shorter the tripping time
- tripping of short-circuit protection (magnetic tripping device): if the current exceeds the threshold of this protection device, the breaking time is less than 10 milliseconds.

For short-circuit currents exceeding 20 times the rated current, the time-current curves do not give a sufficiently precise representation. The breaking of high short-circuit currents is characterized by the current limiting curves, in peak current and in energy. The total breaking time can be estimated at 5 times the value of the ratio  $(I^2t)/(I^2)$ .

### Verification of the discrimination between two circuit breakers

By superimposing the curve of a circuit breaker on that of the circuit breaker installed upstream, one can check whether this combination will be discriminating in cases of overload (discrimination for all current values, up to the magnetic threshold of the upstream circuit breaker). This verification is useful when one of the two circuit breakers has adjustable thresholds; for fixed-threshold devices, this information is provided directly by the discrimination tables. To check discrimination on short circuit, the energy characteristics of the two devices must be compared.

### Alternative current 50/60 Hz

**C60BP, C60BPR, C60SP**  
 According to IEC/EN 60947-2 (reference temperature 25°C)  
 Curves Z, B, C, D

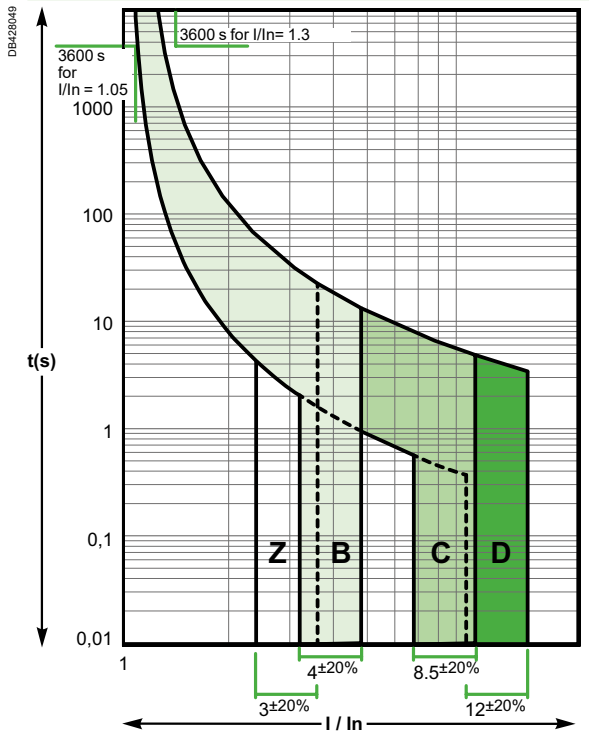

**C60N, C60H, C60L, C60CTRL**  
 According to IEC/EN 60947-2 (reference temperature 50°C)  
 Curves Z, B, C, D

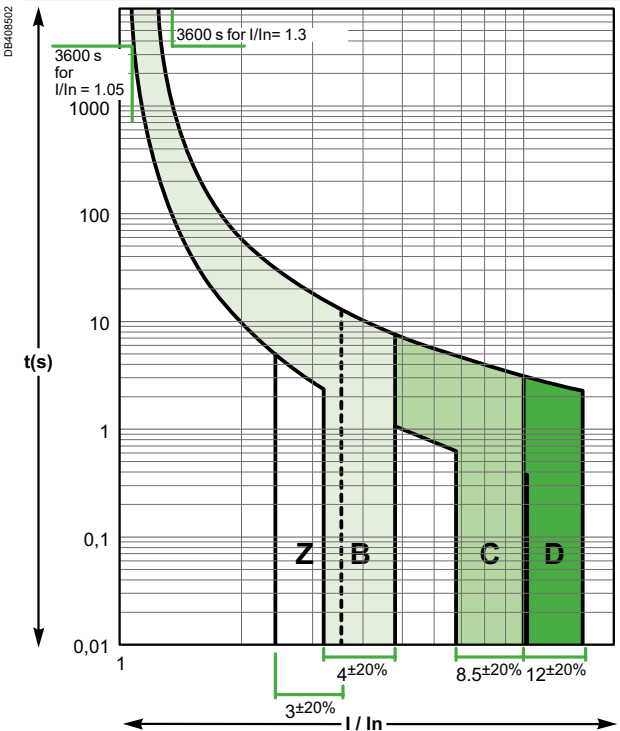

Note: IEC/EN 60947-2 tripping curves, respecting the tripping time specified by the standards UL 489, CSA C22.2 No 5, UL 1077 and CSA C22.2 No 235

**Direct current**

**C60BP, C60BPR, C60SP**  
 According to IEC/EN 60947-2 (reference temperature 25°C)  
 Curves Z, B, C, D

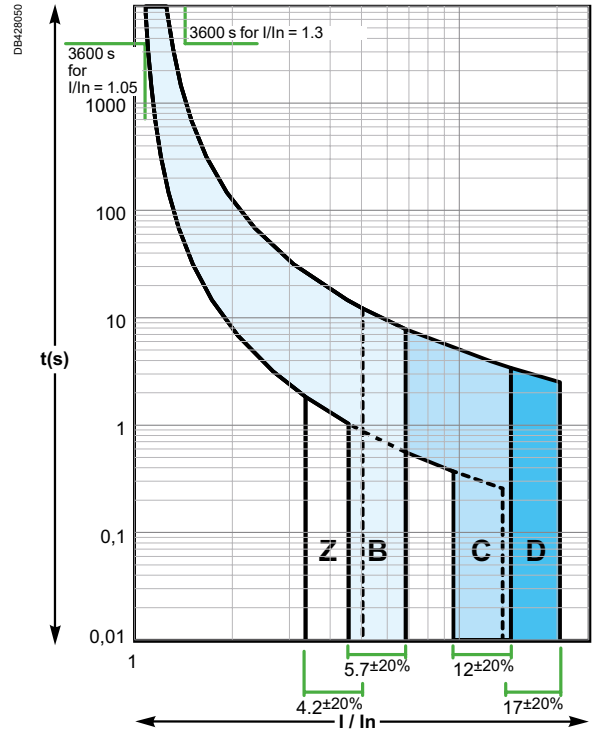

**C60N, C60H, C60L, C60CTRL**  
 According to IEC/EN 60947-2 (reference temperature 50°C)  
 Curves Z, B, C, D

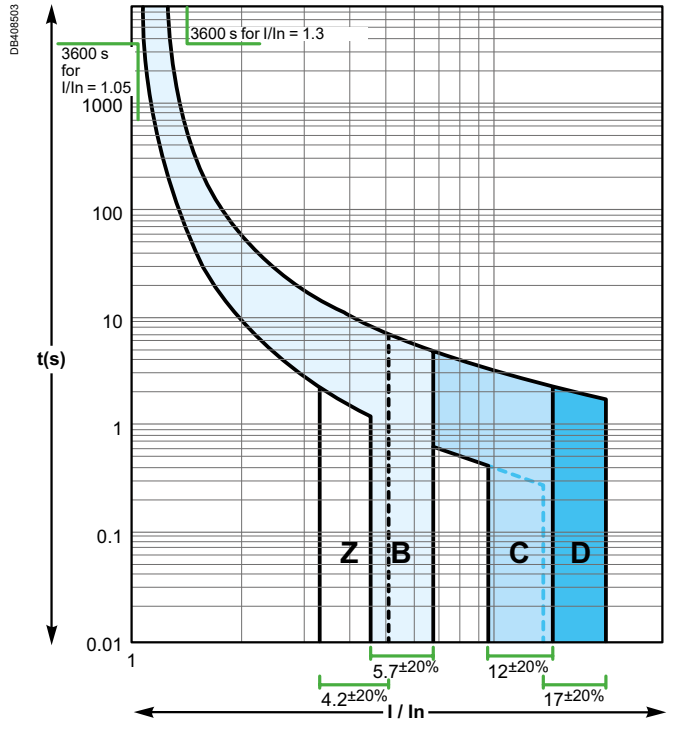

Note: IEC/EN 60947-2 tripping curves, respecting the tripping time specified by the standards UL 489, CSA C22.2 No 5, UL 1077 and CSA C22.2 No 235

**C60H-DC**  
 According to IEC/EN 60947-2 (reference temperature 25°C)  
 Curves B, C, K

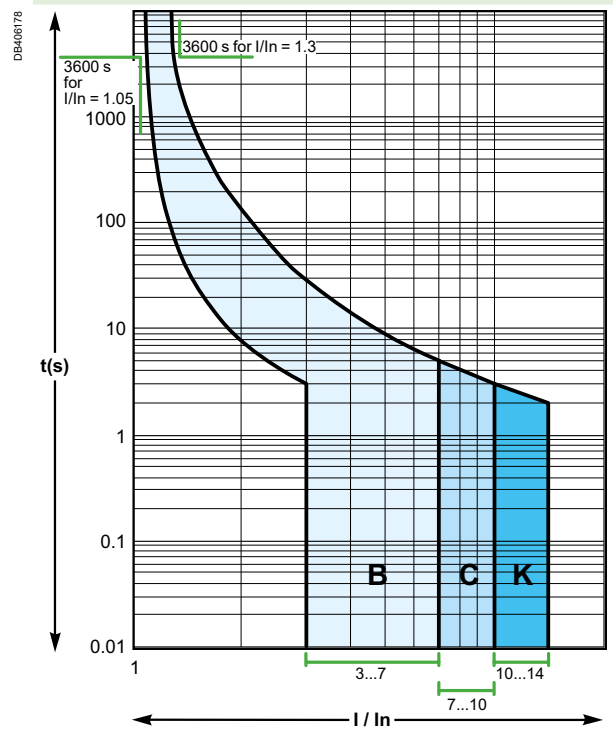

Note: IEC/EN 60947-2 tripping curves, respecting the tripping time specified by

The circuit-breaker characteristics chosen depend on the type of load downstream of the installation.

The rating depends on the size of the cables to be protected and the curves depend on the load inrush current.

**Product selection according to the load inrush current**

When certain "capacitive" loads are switched on, very high inrush currents appear during the first milliseconds of operation. The following graphs show the average non-tripping curves of our products for this time range (50 μs to 10 ms).

**C60N, C60H, C60L, C60CTRL**

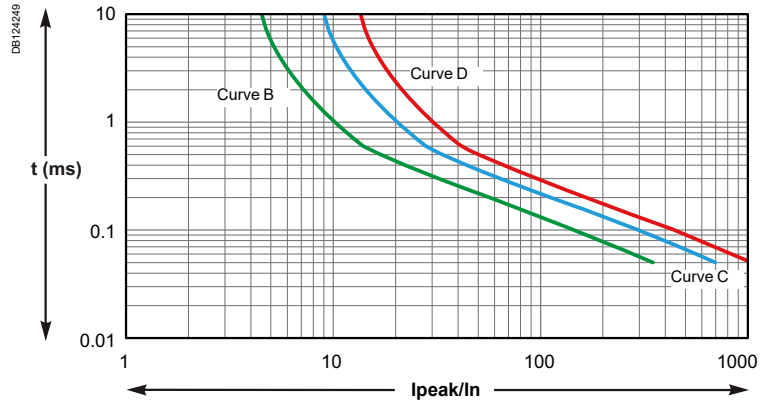

**C60H-DC**

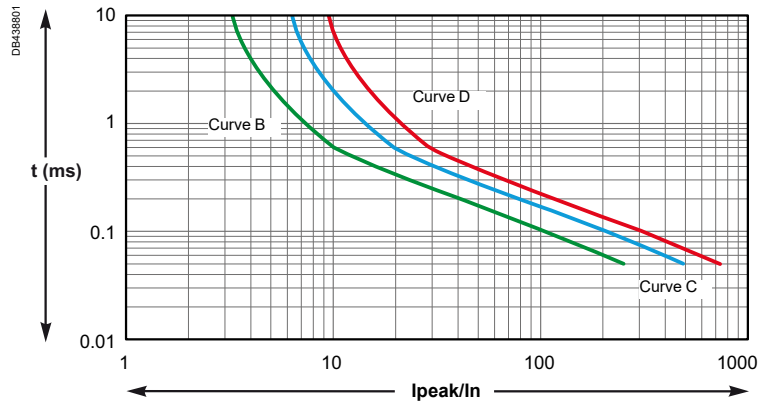

This information allows us to select the most appropriate product, according to the load specifications: curve and rating.

**Example**

When an C60 is used with a load with current peaks in the order of 200 I<sub>n</sub> during the first 0.1 millisecond, a curve C or D product must be installed.

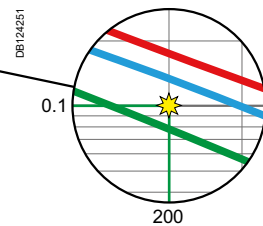
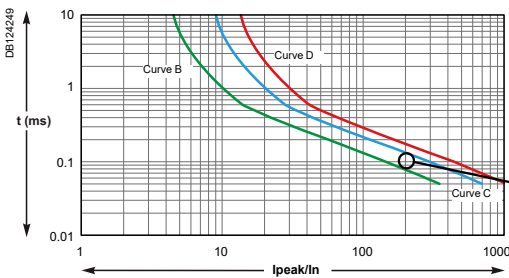

This application sheet is intended to provide guidance for selecting the best protection and control components for a given DC system. The scope is DC system supplied by rectifier (AC/DC or DC/DC converter) and/or battery, isolated or connected to earth. The application voltages are 24 V DC, 48 V DC, 110 V DC and 220 V DC.

### A. Circuit breaker selection for 24/48 V DC according to the method of earthing

Refer to Tables A of Application Guide CA908061E.

C60BP / C60BPR / C60SP and C60N/H/L circuit breakers follow the wiring rules of iC60N/H/L circuit breakers.

Multi9 C60H-DC circuit breakers follow the wiring rules of Acti9 C60H-DC circuit breakers.

The breaking capacities of these products are available in catalog pages.

### B. Circuit breaker selection for 110 V DC according to the method of earthing

Refer to Tables B of Application Guide CA908061E.

Multi9 C60H-DC circuit breakers follow the rules of Acti9 C60H-DC circuit breakers.

| Ue = 110 V DC  |   |  |  |  |  |
|--|---|--|--|--|--|
| Method of earthing                                       | IT  | TN   | TN   | TN   | TN   |
|  | <b>Isolated from earth</b><br>+ and - conductors protected and disconnected | <b>- (or +) earthed</b><br>+ and - conductors protected and disconnected | <b>Midpoint earthed (not distributed)</b><br>+ and - conductors protected and disconnected | <b>- (or +) earthed</b><br>+ (or -) conductor protected and disconnected | <b>- (or +) earthed</b><br>+ (or -) conductor protected and disconnected |
|  |   |  |  |  |  |
| <b>Breaking capacity</b><br>Isc ≤ 10 kA<br>(UL Standard) |   |  |  |  |  |
| Isc ≤ 20 kA  |   |  |  |  |  |
| Isc ≤ 25 kA  |   |  |  |  |  |
| Isc ≤ 30kA   |   |  |  |  |  |
|  | C60SP 4P  | C60BP, C60BPR, C60SP 3P  | C60BP, C60BPR, C60SP 2P  | C60BP, C60BPR, C60SP 2P  | C60BP, C60BPR, C60SP 2P  |
|  | C60N/H/L 4P   | C60N/H/L 3P  | C60N/H/L 2P  | C60N/H/L 2P  | C60N/H/L 2P  |
|  | C60H/L 4P   | C60H/L 3P  | C60H/L 2P  | C60H/L 2P  | C60H/L 2P  |
|  | C60L 4P   | C60L 3P  | C60L 2P  | C60L 2P  | C60L 2P  |

Note: This table is applicable for 125 V DC floating battery voltage.

### C. Circuit breaker selection 220 - 380 V DC according to the method of earthing

Refer to Tables C of Application Guide CA908061E.

## Influence of temperature on the operation

| Devices  | Characteristics influenced by temperature | Temperature |       |
|--|---|-------------|-------|
|  |   | Mini        | Maxi  |
| C60BP, C60BPR, C60SP, C60N, C60H, C60L, C60CTRL circuit breakers | Tripping on overload                      | -30°C       | +70°C |
| N40N circuit breakers  | Tripping on overload                      | -25°C       | +70°C |
| C60H-DC circuit breakers   | Tripping on overload                      | -25°C       | +70°C |
| Circuit breakers with  | Vigi AC Type                              | -5°C        | +60°C |
|  | Vigi A-SI Type                            | -25°C       | +60°C |
| N40 Vigi   | Tripping on overload                      | -5°C        | +60°C |
| GFP A-SI Type  | Maximum operating current                 | -25°C       | +60°C |
| RCCB-ID 125 A  | Maximum operating current                 | -25°C       | +40°C |
| iID B-SI type  | Maximum operating current                 | -25°C       | +60°C |

Note: the temperature considered is the temperature viewed through the device.

## Circuit breakers

### High temperatures

- A rise in temperature decreases the tripping current of the thermal protection.
- Protection is still ensured: the tripping threshold remains lower than the current acceptable by the cable ( $I_2$ )
- To prevent nuisance tripping, it should be checked that this threshold remains higher than the maximum operating current ( $I_B$ ) of the circuit, defined by:

- the rated load currents,
- the coefficients of expansion and simultaneity of use.

If the temperature is sufficiently high for the tripping threshold to become lower than the operating current  $I_B$ , switchboard ventilation should be provided for.

### Low temperatures

- A fall in temperature increases the tripping current of the thermal protection.
- There is no risk of nuisance tripping: the threshold remains higher than the maximum operating current of the circuit ( $I_B$ ) demanded by the loads.
- It should be checked that the cable remains suitably protected, i.e. that its acceptable current ( $I_2$ ) is higher than the values shown in the following tables (in amperes).

When the ambient temperature could vary within a broad range, both these aspects must be taken into account:

- the difference between the maximum operating current of the circuit ( $I_B$ ) and the tripping threshold of the circuit breaker for the minimum ambient temperature,
- the difference between the strength of the cable ( $I_2$ ) and the maximum tripping threshold of the circuit breaker for the maximum ambient temperature.



### Maximum permissible current

- The maximum current allowed to flow through the device depends on the ambient temperature in which it is placed.
- The ambient temperature is the temperature inside the enclosure or switchboard in which the devices are installed.
- The reference temperature is in a halftone colour for the different devices.
- When several devices operating simultaneously are mounted side by side in a small enclosure, a temperature rise in the enclosure results in a reduction in the operating current. A reduction coefficient of 0.8 will then have to be assigned to the rating (already derated, if applicable, depending on the ambient temperature).

■ Example:

Depending on the ambient temperature and the method of installation, the table below shows how to determine, for a C60, the operating currents not to be exceeded for ratings 25 A, 32 A and 40 A (reference temperature 50°C).

| Operating current not to be exceeded (A) |                    |                   |       |       |  |                        |                          |
|--|--------------------|-------------------|-------|-------|--|------------------------|--------------------------|
| Installation conditions (IEC 60947-2)    |                    | C60 alone         |       |       | Several C60 in the same enclosure (calculate with the reduction coefficient indicated below) |                        |                          |
| Ambient temperature (°C)                 |                    | 35 °C             | 50 °C | 65 °C | 35 °C  | 50 °C                  | 65 °C                    |
| Type                                     | Nominal rating (A) | Actual rating (A) |       |       |  |                        |                          |
| C60                                      | 25                 | 26.7              | 25    | 23.2  | $26.7 \times 0.8 = 21.4$   | $25 \times 0.8 = 20$   | $23.2 \times 0.8 = 18.6$ |
|  | 32                 | 34                | 32    | 29.9  | $34 \times 0.8 = 27$   | $32 \times 0.8 = 25.6$ | $29.9 \times 0.8 = 24$   |
|  | 40                 | 42.9              | 40    | 36.9  | $42.9 \times 0.8 = 34.3$   | $40 \times 0.8 = 32$   | $36.9 \times 0.8 = 29.5$ |

C60BP, C60BPR, C60SP derating table

| C60BP,<br>C60BPR,<br>C60SP | Ambient temperature (°C) |      |      |      |      |      |      |      |      |      |      |      |      |      |      |      |      |      |      |      |
|----------------------------|--------------------------|------|------|------|------|------|------|------|------|------|------|------|------|------|------|------|------|------|------|------|
|                            | Rating                   | -30  | -25  | -20  | -15  | -10  | -5   | 0    | +5   | +10  | +15  | +20  | +25  | +30  | +35  | +40  | +45  | +50  | +55  | +60  |
| 0.5A                       | 0.6                      | 0.6  | 0.6  | 0.6  | 0.6  | 0.6  | 0.6  | 0.5  | 0.5  | 0.5  | 0.5  | 0.5  | 0.5  | 0.5  | 0.5  | 0.5  | 0.4  | 0.4  | 0.4  | 0.4  |
| 1A                         | 1.4                      | 1.3  | 1.3  | 1.3  | 1.2  | 1.2  | 1.2  | 1.1  | 1.1  | 1.1  | 1.0  | 1.0  | 1.0  | 0.9  | 0.9  | 0.8  | 0.8  | 0.7  | 0.7  | 0.6  |
| 2A                         | 2.5                      | 2.5  | 2.4  | 2.4  | 2.3  | 2.3  | 2.3  | 2.2  | 2.2  | 2.1  | 2.1  | 2.0  | 1.9  | 1.9  | 1.8  | 1.8  | 1.7  | 1.6  | 1.6  | 1.4  |
| 3A                         | 3.7                      | 3.7  | 3.6  | 3.6  | 3.5  | 3.4  | 3.4  | 3.3  | 3.2  | 3.1  | 3.1  | 3.0  | 2.9  | 2.8  | 2.8  | 2.7  | 2.6  | 2.5  | 2.4  | 2.2  |
| 4A                         | 5.0                      | 4.9  | 4.8  | 4.8  | 4.7  | 4.6  | 4.5  | 4.4  | 4.3  | 4.2  | 4.1  | 4.0  | 3.9  | 3.8  | 3.7  | 3.6  | 3.4  | 3.3  | 3.2  | 2.9  |
| 5A                         | 6.2                      | 6.1  | 6.0  | 5.9  | 5.8  | 5.7  | 5.6  | 5.5  | 5.4  | 5.2  | 5.1  | 5.0  | 4.9  | 4.8  | 4.6  | 4.5  | 4.3  | 4.2  | 4.1  | 3.7  |
| 6A                         | 7.8                      | 7.6  | 7.5  | 7.3  | 7.2  | 7.0  | 6.9  | 6.7  | 6.5  | 6.4  | 6.2  | 6.0  | 5.8  | 5.6  | 5.4  | 5.2  | 5.0  | 4.8  | 4.5  | 4.0  |
| 8A                         | 9.9                      | 9.8  | 9.6  | 9.5  | 9.3  | 9.1  | 8.9  | 8.8  | 8.6  | 8.4  | 8.2  | 8.0  | 7.8  | 7.6  | 7.4  | 7.2  | 6.9  | 6.7  | 6.5  | 6.0  |
| 10A                        | 12.4                     | 12.2 | 12.0 | 11.8 | 11.6 | 11.4 | 11.2 | 10.9 | 10.7 | 10.5 | 10.2 | 10.0 | 9.7  | 9.5  | 9.2  | 9.0  | 8.7  | 8.4  | 8.1  | 7.4  |
| 13A                        | 15.6                     | 15.4 | 15.2 | 15.0 | 14.7 | 14.5 | 14.3 | 14.0 | 13.8 | 13.5 | 13.3 | 13.0 | 12.7 | 12.5 | 12.2 | 11.9 | 11.6 | 11.3 | 11.0 | 10.4 |
| 15A                        | 18.1                     | 17.8 | 17.6 | 17.3 | 17.0 | 16.7 | 16.5 | 16.2 | 15.9 | 15.6 | 15.3 | 15.0 | 14.7 | 14.4 | 14.0 | 13.7 | 13.4 | 13.0 | 12.7 | 11.9 |
| 16A                        | 18.9                     | 18.6 | 18.4 | 18.1 | 17.9 | 17.6 | 17.4 | 17.1 | 16.8 | 16.6 | 16.3 | 16.0 | 15.7 | 15.4 | 15.1 | 14.8 | 14.5 | 14.2 | 13.9 | 13.2 |
| 20A                        | 24.6                     | 24.3 | 23.9 | 23.5 | 23.1 | 22.7 | 22.2 | 21.8 | 21.4 | 20.9 | 20.5 | 20.0 | 19.5 | 19.0 | 18.5 | 18.0 | 17.5 | 16.9 | 16.4 | 15.2 |
| 25A                        | 30.1                     | 29.7 | 29.3 | 28.8 | 28.4 | 27.9 | 27.5 | 27.0 | 26.5 | 26.0 | 25.5 | 25.0 | 24.5 | 23.9 | 23.4 | 22.8 | 22.3 | 21.7 | 21.1 | 19.8 |
| 30A                        | 38.2                     | 37.6 | 36.9 | 36.2 | 35.5 | 34.7 | 34.0 | 33.2 | 32.5 | 31.7 | 30.8 | 30.0 | 29.1 | 28.2 | 27.3 | 26.4 | 25.4 | 24.4 | 23.3 | 21.0 |
| 32A                        | 40.2                     | 39.5 | 38.8 | 38.1 | 37.4 | 36.7 | 36.0 | 35.2 | 34.4 | 33.6 | 32.8 | 32.0 | 31.1 | 30.3 | 29.4 | 28.4 | 27.5 | 26.5 | 25.4 | 23.2 |
| 35A                        | 42.5                     | 41.9 | 41.2 | 40.6 | 39.9 | 39.3 | 38.6 | 37.9 | 37.2 | 36.5 | 35.7 | 35.0 | 34.2 | 33.5 | 32.7 | 31.8 | 31.0 | 30.1 | 29.2 | 27.4 |
| 40A                        | 48.9                     | 48.1 | 47.4 | 46.6 | 45.9 | 45.1 | 44.3 | 43.4 | 42.6 | 41.8 | 40.9 | 40.0 | 39.1 | 38.2 | 37.2 | 36.2 | 35.2 | 34.2 | 33.1 | 30.9 |
| 45A                        | 54.7                     | 53.9 | 53.1 | 52.2 | 51.4 | 50.5 | 49.7 | 48.8 | 47.8 | 46.9 | 46.0 | 45.0 | 44.0 | 43.0 | 42.0 | 40.9 | 39.8 | 38.7 | 37.5 | 35.1 |
| 50A                        | 59.8                     | 59.0 | 58.2 | 57.3 | 56.5 | 55.6 | 54.7 | 53.8 | 52.9 | 51.9 | 51.0 | 50.0 | 49.0 | 48.0 | 47.0 | 45.9 | 44.8 | 43.7 | 42.6 | 40.2 |
| 63A                        | 80.0                     | 78.6 | 77.2 | 75.7 | 74.2 | 72.7 | 71.2 | 69.6 | 68.0 | 66.4 | 64.7 | 63.0 | 61.2 | 59.4 | 57.5 | 55.6 | 53.5 | 51.4 | 49.2 | 44.5 |

C60N, C60H, C60L, C60CTRL derating table

| C60N, C60H,<br>C60L,<br>C60CTRL | Ambient temperature (°C) |      |      |      |      |      |      |      |      |      |      |      |      |      |      |      |     |      |      |      |      |
|---------------------------------|--------------------------|------|------|------|------|------|------|------|------|------|------|------|------|------|------|------|-----|------|------|------|------|
|                                 | Rating                   | -30  | -25  | -20  | -15  | -10  | -5   | 0    | +5   | +10  | +15  | +20  | +25  | +30  | +35  | +40  | +45 | +50  | +55  | +60  | +65  |
| 1A                              | 1.31                     | 1.3  | 1.28 | 1.27 | 1.25 | 1.23 | 1.21 | 1.19 | 1.17 | 1.15 | 1.13 | 1.11 | 1.09 | 1.07 | 1.05 | 1.02 | 1   | 0.98 | 0.95 | 0.93 | 0.91 |
| 2A                              | 2.55                     | 2.59 | 2.56 | 2.52 | 2.49 | 2.45 | 2.41 | 2.37 | 2.34 | 2.3  | 2.26 | 2.22 | 2.17 | 2.13 | 2.09 | 2.04 | 2   | 1.95 | 1.91 | 1.88 | 1.84 |
| 3A                              | 3.81                     | 4.04 | 3.98 | 3.92 | 3.85 | 3.79 | 3.73 | 3.66 | 3.59 | 3.52 | 3.45 | 3.38 | 3.31 | 3.23 | 3.16 | 3.08 | 3   | 2.92 | 2.83 | 2.82 | 2.76 |
| 4A                              | 4.9                      | 4.86 | 4.81 | 4.76 | 4.7  | 4.65 | 4.59 | 4.54 | 4.48 | 4.42 | 4.37 | 4.31 | 4.25 | 4.19 | 4.13 | 4.06 | 4   | 3.94 | 3.87 | 3.81 | 3.74 |
| 6A                              | 7.93                     | 7.82 | 7.71 | 7.6  | 7.49 | 7.38 | 7.27 | 7.15 | 7.03 | 6.91 | 6.79 | 6.66 | 6.54 | 6.41 | 6.27 | 6.14 | 6   | 5.86 | 5.71 | 5.56 | 5.42 |
| 10A                             | 13.3                     | 13.2 | 13   | 12.8 | 12.6 | 12.4 | 12.2 | 12   | 11.8 | 11.6 | 11.4 | 11.2 | 10.9 | 10.7 | 10.5 | 10.2 | 10  | 9.8  | 9.5  | 9.2  | 9    |
| 13A                             | 17                       | 16.9 | 16.6 | 16.4 | 16.2 | 15.9 | 15.7 | 15.4 | 15.2 | 14.9 | 14.7 | 14.4 | 14.1 | 13.9 | 13.6 | 13.3 | 13  | 12.7 | 12.4 | 12.1 | 11.8 |
| 16A                             | 20                       | 19.8 | 19.5 | 19.3 | 19.1 | 18.8 | 18.6 | 18.4 | 18.1 | 17.9 | 17.6 | 17.3 | 17.1 | 16.8 | 16.6 | 16.3 | 16  | 15.7 | 15.4 | 15.1 | 14.8 |
| 20A                             | 26.9                     | 26.6 | 26.2 | 25.8 | 25.4 | 25   | 24.6 | 24.2 | 23.7 | 23.3 | 22.9 | 22.4 | 22   | 21.5 | 21   | 20.5 | 20  | 19.5 | 18.9 | 18.4 | 17.9 |
| 25A                             | 32.9                     | 32.5 | 32.1 | 31.6 | 31.1 | 30.7 | 30.2 | 29.7 | 29.2 | 28.7 | 28.2 | 27.7 | 27.2 | 26.7 | 26.1 | 25.6 | 25  | 24.4 | 23.8 | 23.2 | 22.6 |
| 32A                             | 41.5                     | 41.1 | 40.5 | 40   | 39.4 | 38.9 | 38.3 | 37.7 | 37.1 | 36.5 | 35.9 | 35.3 | 34.7 | 34   | 33.4 | 32.7 | 32  | 31.3 | 30.6 | 29.9 | 29.1 |
| 40A                             | 53.7                     | 52.9 | 52.2 | 51.4 | 50.6 | 49.8 | 49   | 48.2 | 47.3 | 46.5 | 45.6 | 44.7 | 43.8 | 42.9 | 42   | 41   | 40  | 39   | 37.9 | 36.9 | 35.8 |
| 50A                             | 65                       | 64.3 | 63.5 | 62.6 | 61.7 | 60.8 | 59.9 | 59   | 58.1 | 57.1 | 56.2 | 55.2 | 54.2 | 53.2 | 52.1 | 51.1 | 50  | 48.9 | 47.8 | 46.7 | 45.5 |
| 63A                             | 85.5                     | 84.6 | 83.3 | 82   | 80.7 | 79.4 | 78   | 76.7 | 75.3 | 73.9 | 72.4 | 70.9 | 69.4 | 67.9 | 66.3 | 64.7 | 63  | 61.3 | 59.5 | 57.8 | 56   |

N40N, N40 vigi derating table

| N40N,<br>N40 Vigi | Ambient temperature (°C) |      |      |      |      |      |      |      |      |      |      |      |      |      |      |     |      |      |      |      |
|-------------------|--------------------------|------|------|------|------|------|------|------|------|------|------|------|------|------|------|-----|------|------|------|------|
|                   | -25                      | -20  | -15  | -10  | -5   | 0    | +5   | +10  | +15  | +20  | +25  | +30  | +35  | +40  | +45  | +50 | +55  | +60  | +65  | +70  |
| 1 A               | 1.66                     | 1.62 | 1.59 | 1.55 | 1.51 | 1.47 | 1.43 | 1.39 | 1.35 | 1.3  | 1.26 | 1.21 | 1.16 | 1.11 | 1.06 | 1   | 0.94 | 0.88 | 0.81 | 0.73 |
| 2 A               | 2.64                     | 2.6  | 2.56 | 2.52 | 2.48 | 2.44 | 2.4  | 2.36 | 2.32 | 2.28 | 2.23 | 2.19 | 2.14 | 2.1  | 2.05 | 2   | 1.95 | 1.9  | 1.85 | 1.79 |
| 3 A               | 3.97                     | 3.91 | 3.86 | 3.8  | 3.74 | 3.68 | 3.61 | 3.55 | 3.49 | 3.42 | 3.36 | 3.29 | 3.22 | 3.15 | 3.07 | 3   | 2.92 | 2.85 | 2.77 | 2.68 |
| 4 A               | 5.19                     | 5.12 | 5.05 | 4.98 | 4.9  | 4.83 | 4.75 | 4.67 | 4.6  | 4.52 | 4.43 | 4.35 | 4.27 | 4.18 | 4.09 | 4   | 3.91 | 3.81 | 3.72 | 3.62 |
| 6 A               | 7.42                     | 7.34 | 7.25 | 7.16 | 7.07 | 6.98 | 6.89 | 6.8  | 6.7  | 6.61 | 6.51 | 6.41 | 6.31 | 6.21 | 6.11 | 6   | 5.89 | 5.78 | 5.67 | 5.56 |
| 10 A              | 12.9                     | 12.7 | 12.5 | 12.3 | 12.2 | 12   | 11.8 | 11.6 | 11.4 | 11.2 | 11   | 10.8 | 10.6 | 10.4 | 10.2 | 10  | 9.8  | 9.6  | 9.3  | 9.1  |
| 16 A              | 20.4                     | 20.1 | 19.8 | 19.6 | 19.3 | 19   | 18.7 | 18.5 | 18.2 | 17.9 | 17.6 | 17.3 | 17   | 16.7 | 16.3 | 16  | 15.7 | 15.3 | 15   | 14.6 |
| 20 A              | 25.7                     | 25.3 | 25   | 24.6 | 24.3 | 23.9 | 23.6 | 23.2 | 22.8 | 22.4 | 22   | 21.7 | 21.3 | 20.8 | 20.4 | 20  | 19.6 | 19.1 | 18.7 | 18.2 |
| 25 A              | 31.6                     | 31.2 | 30.8 | 30.4 | 30   | 29.6 | 29.2 | 28.7 | 28.3 | 27.8 | 27.4 | 26.9 | 26.5 | 26   | 25.5 | 25  | 24.5 | 24   | 23.5 | 22.9 |
| 32 A              | 41.1                     | 40.5 | 40   | 39.4 | 38.9 | 38.3 | 37.7 | 37.1 | 36.5 | 35.9 | 35.3 | 34.7 | 34   | 33.4 | 32.7 | 32  | 31.3 | 30.6 | 29.9 | 29.1 |
| 40 A              | 52                       | 51.3 | 50.6 | 49.8 | 49.1 | 48.3 | 47.6 | 46.8 | 46   | 45.2 | 44.4 | 43.5 | 42.7 | 41.8 | 40.9 | 40  | 39.1 | 38.1 | 37.1 | 36.1 |

C60H-DC derating table

| C60H-DC | Ambient temperature (°C) |      |      |      |      |      |      |      |      |      |     |      |      |      |      |      |      |      |      |      |
|---------|--------------------------|------|------|------|------|------|------|------|------|------|-----|------|------|------|------|------|------|------|------|------|
|         | -25                      | -20  | -15  | -10  | -5   | 0    | +5   | +10  | +15  | +20  | +25 | +30  | +35  | +40  | +45  | +50  | +55  | +60  | +65  | +70  |
| 0.5A    | 0.62                     | 0.61 | 0.6  | 0.59 | 0.58 | 0.56 | 0.55 | 0.54 | 0.53 | 0.51 | 0.5 | 0.49 | 0.47 | 0.46 | 0.44 | 0.43 | 0.41 | 0.39 | 0.38 | 0.36 |
| 1 A     | 1.17                     | 1.15 | 1.14 | 1.12 | 1.1  | 1.09 | 1.07 | 1.05 | 1.04 | 1.02 | 1   | 0.98 | 0.96 | 0.94 | 0.92 | 0.9  | 0.88 | 0.86 | 0.84 | 0.82 |
| 2 A     | 2.5                      | 2.45 | 2.41 | 2.36 | 2.31 | 2.26 | 2.21 | 2.16 | 2.11 | 2.06 | 2   | 1.94 | 1.88 | 1.82 | 1.76 | 1.7  | 1.63 | 1.56 | 1.48 | 1.41 |
| 3 A     | 3.71                     | 3.65 | 3.58 | 3.51 | 3.45 | 3.38 | 3.3  | 3.23 | 3.16 | 3.08 | 3   | 2.92 | 2.84 | 2.75 | 2.66 | 2.57 | 2.48 | 2.38 | 2.27 | 2.17 |
| 4 A     | 4.99                     | 4.9  | 4.81 | 4.71 | 4.62 | 4.52 | 4.42 | 4.32 | 4.22 | 4.11 | 4   | 3.89 | 3.77 | 3.65 | 3.53 | 3.4  | 3.27 | 3.13 | 2.98 | 2.83 |
| 5 A     | 5.92                     | 5.83 | 5.74 | 5.66 | 5.57 | 5.48 | 5.39 | 5.29 | 5.2  | 5.1  | 5   | 4.9  | 4.8  | 4.69 | 4.58 | 4.47 | 4.36 | 4.24 | 4.12 | 4    |
| 6 A     | 7.15                     | 7.04 | 6.94 | 6.83 | 6.71 | 6.6  | 6.48 | 6.37 | 6.25 | 6.12 | 6   | 5.87 | 5.74 | 5.61 | 5.47 | 5.33 | 5.19 | 5.04 | 4.89 | 4.73 |
| 10 A    | 12.4                     | 12.2 | 11.9 | 11.7 | 11.5 | 11.3 | 11   | 10.8 | 10.5 | 10.3 | 10  | 9.7  | 9.5  | 9.2  | 8.9  | 8.6  | 8.3  | 7.9  | 7.6  | 7.2  |
| 13 A    | 15.3                     | 15.1 | 14.9 | 14.6 | 14.4 | 14.2 | 14   | 13.7 | 13.5 | 13.3 | 13  | 12.8 | 12.5 | 12.2 | 12   | 11.7 | 11.4 | 11.1 | 10.8 | 10.5 |
| 15 A    | 18.3                     | 18   | 17.7 | 17.4 | 17.1 | 16.7 | 16.4 | 16.1 | 15.7 | 15.4 | 15  | 14.6 | 14.3 | 13.9 | 13.5 | 13   | 12.6 | 12.2 | 11.7 | 11.2 |
| 16 A    | 19.1                     | 18.9 | 18.6 | 18.3 | 18   | 17.6 | 17.3 | 17   | 16.7 | 16.3 | 16  | 15.7 | 15.3 | 14.9 | 14.6 | 14.2 | 13.8 | 13.4 | 13   | 12.5 |
| 20 A    | 23.7                     | 23.4 | 23   | 22.7 | 22.3 | 21.9 | 21.6 | 21.2 | 20.8 | 20.4 | 20  | 19.6 | 19.2 | 18.7 | 18.3 | 17.9 | 17.4 | 16.9 | 16.4 | 15.9 |
| 25 A    | 29.9                     | 29.5 | 29   | 28.5 | 28.1 | 27.6 | 27.1 | 26.6 | 26.1 | 25.5 | 25  | 24.5 | 23.9 | 23.3 | 22.7 | 22.1 | 21.5 | 20.9 | 20.2 | 19.6 |
| 30 A    | 36.7                     | 36.1 | 35.5 | 34.9 | 34.2 | 33.5 | 32.9 | 32.2 | 31.5 | 30.7 | 30  | 29.2 | 28.5 | 27.7 | 26.8 | 26   | 25.1 | 24.2 | 23.2 | 22.3 |
| 32 A    | 37.9                     | 37.4 | 36.8 | 36.2 | 35.7 | 35.1 | 34.5 | 33.9 | 33.3 | 32.6 | 32  | 31.4 | 30.7 | 30   | 29.3 | 28.6 | 27.9 | 27.1 | 26.3 | 25.5 |
| 40 A    | 48.2                     | 47.4 | 46.7 | 45.9 | 45.1 | 44.3 | 43.5 | 42.6 | 41.8 | 40.9 | 40  | 39.1 | 38.2 | 37.2 | 36.2 | 35.2 | 34.2 | 33.1 | 32   | 30.8 |
| 50 A    | 59.1                     | 58.3 | 57.4 | 56.5 | 55.6 | 54.7 | 53.8 | 52.9 | 52   | 51   | 50  | 49   | 48   | 46.9 | 45.9 | 44.8 | 43.6 | 42.5 | 41.3 | 40.1 |
| 63 A    | 76.9                     | 75.6 | 74.3 | 73   | 71.7 | 70.3 | 68.9 | 67.5 | 66   | 64.5 | 63  | 61.4 | 59.8 | 58.2 | 56.5 | 54.7 | 52.9 | 51.1 | 49.1 | 47.1 |

RCCB

In all cases, the RCCB are correctly protected against overloads by a circuit breaker with a lower or equal rating, operating at the same ambient temperature.

## Acti9 products

The following table indicates the average dissipated power per pole in W for a current equal to the rating of the device and at the operating voltage.

| Rating (A)  | 0.5 | 1 | 1.6 | 2 | 2.5 | 3 | 4 | 6 | 6.3 | 10 | 12.5 | 13 | 16 | 20  | 25  | 32  | 40  | 45  | 50 | 63 | 80  | 100 | 125 |  |
|-------------|-----|---|-----|---|-----|---|---|---|-----|----|------|----|----|-----|-----|-----|-----|-----|----|----|-----|-----|-----|--|
| <b>RCCB</b> |     |   |     |   |     |   |   |   |     |    |      |    |    |     |     |     |     |     |    |    |     |     |     |  |
| iID 2P      |     |   |     |   |     |   |   |   |     |    |      |    |    | 0.8 |     | 0.9 |     | 2.6 |    |    | 2.6 | 3   | 5   |  |
| 4P          |     |   |     |   |     |   |   |   |     |    |      |    |    |     | 0.7 |     | 1.9 |     |    |    | 1.5 | 2.6 | 4.3 |  |

Note: When the enclosure's thermal balance, consider the 4P devices load is only on 3 phases.

## Multi9 products

The following table indicates the average dissipated power per pole in W for a current equal to the rating of the device and at the operating voltage.

| Rating (A)                             | 0.5 | 1   | 2   | 3   | 4   | 5   | 6   | 8   | 10  | 13  | 15  | 16  | 20  | 25  | 30  | 32  | 35  | 40  | 45  | 50  | 63  | 80 | 100 | 125 |  |
|--|-----|-----|-----|-----|-----|-----|-----|-----|-----|-----|-----|-----|-----|-----|-----|-----|-----|-----|-----|-----|-----|----|-----|-----|--|
| <b>Circuit breakers</b>                |     |     |     |     |     |     |     |     |     |     |     |     |     |     |     |     |     |     |     |     |     |    |     |     |  |
| C60BP, C60BPR, C60SP                   | 2.6 | 1.3 | 1.7 | 1.9 | 2.0 | 2.2 | 1.2 | 1.7 | 1.9 | 2.4 | 2.3 | 2.6 | 2.2 | 3.4 | 2.5 | 2.8 | 3.5 | 3.6 | 3.9 | 4.8 | 4.8 |    |     |     |  |
| C60N, C60H, C60L, C60CTRL              |     | 1.3 | 1.7 | 1.9 | 2.0 |     | 1.2 |     | 1.9 | 2.4 |     | 2.6 | 2.2 | 2.7 |     | 3.2 |     | 3.6 |     | 4.8 | 4.3 |    |     |     |  |
| N40N                                   |     | 2.5 | 1.9 | 2.1 | 2.6 |     | 2.7 |     | 2.7 |     |     | 3.2 | 4.7 | 4.7 |     | 4.6 |     | 5.8 |     |     |     |    |     |     |  |
| C60H-DC                                | 2.6 | 1.3 | 1.7 | 1.9 | 2.0 |     | 1.2 |     | 1.9 | 2.4 |     | 2.6 | 2.2 | 2.7 |     | 3.2 |     | 3.6 |     | 4.8 | 4.3 |    |     |     |  |
| <b>RCCB</b>                            |     |     |     |     |     |     |     |     |     |     |     |     |     |     |     |     |     |     |     |     |     |    |     |     |  |
| GFP A-SI Type                          |     |     |     |     |     |     |     |     |     |     |     |     |     | 1.4 |     |     |     | 3.6 |     |     | 4.4 |    | 18  |     |  |
| ID AC / A-SI Type                      |     |     |     |     |     |     |     |     |     |     |     |     |     | 1.4 |     |     |     | 3.6 |     |     | 4.4 |    |     |     |  |
| ID B Type                              |     |     |     |     |     |     |     |     |     |     |     |     |     | 1.2 |     |     |     | 2.9 |     |     | 7.2 | 12 |     | 28  |  |
| <b>RCBO</b>                            |     |     |     |     |     |     |     |     |     |     |     |     |     |     |     |     |     |     |     |     |     |    |     |     |  |
| N40 Vigi                               |     |     |     |     |     |     | 4.1 |     | 3.2 |     |     | 3.9 | 4.4 | 4.5 |     |     |     | 6.4 |     |     |     |    |     |     |  |
| <b>Add-on residual current devices</b> |     |     |     |     |     |     |     |     |     |     |     |     |     |     |     |     |     |     |     |     |     |    |     |     |  |
| Vigi C60 AC / A-SI Type                |     |     |     |     |     |     |     |     |     |     |     |     |     |     |     |     |     |     |     |     | 3.0 |    |     |     |  |
| Vigi N40 AC / A-SI Type                |     |     |     |     |     |     |     |     |     |     |     |     |     |     |     |     |     | 2.1 |     |     |     |    |     |     |  |

Note: RCBO dissipated power per pole is the sum of circuit breaker dissipated power per pole + add-on residual current device dissipated power per pole.  
Example: C60N (63 A) + Vigi C60 (63 A) = 4.3 + 3.0 = 7.3 W.

### Impedance calculation:

$$Z = P / I^2$$

Z: impedance in Ohms

P: dissipated power in Watts (table values)

### Voltage drop calculation:

$$U = P / I$$

U: voltage drop in Volts

P: dissipated power in Watts (table values)

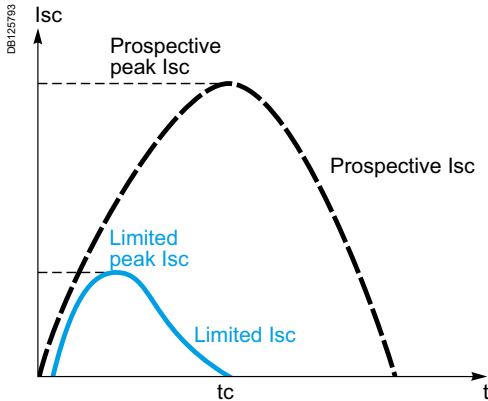

Prospective current and real limit current.

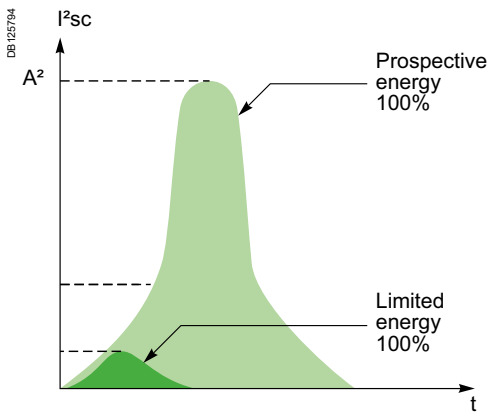

**Definition**

The limiting capacity of a circuit breaker is its ability to lessen the effects of a short-circuit on an electrical installation by reducing the current amplitude and the dissipated power.

**Benefits of limiting**

**Long installation service life**

**Thermal effects**

Lower temperature rise at the conductor level, hence increased service life for cables and all components that are not self-protected (e.g. switches, contactors, etc.)

**Mechanical effects**

Lower electrodynamic repulsion forces, hence less risk of deformation or breakage of electrical contacts and busbars.

**Electromagnetic effects**

Less interference on sensitive equipment located in the vicinity of an electric circuit.

**Savings through cascading**

Cascading is a technique derived directly from current limiting: downstream of a current-limiting circuit breaker it is possible to use circuit breakers of breaking capacity lower than the prospective short-circuit current (in line with the cascading tables). The breaking capacity is heightened thanks to current limiting by the upstream device. Substantial savings can be achieved in this way on switchgear and enclosures.

**Discrimination of protection devices**

The circuit breakers' current limiting capacity improves discrimination with the protection devices located upstream: this is because the required energy passing through the upstream protection device is greatly reduced and can be not enough to cause it to trip. Discrimination can thus be natural without having to install a time-delayed protection device upstream.



### Representation: Current limiting curves

The current limiting capacity of a circuit breaker is reflected by 2 curves which give, as a function of the prospective short-circuit current (current which would flow in the absence of a protection device):

- the real peak current (limited)
- the thermal stress (in A<sup>2</sup>s), this value, multiplied by the resistance of any element through which the short-circuit current passes, gives the power dissipated by this element.

The straight line "10 ms" representing the energy A<sup>2</sup>s of a prospective short-circuit current of a half-period (10 ms) indicates the energy that would be dissipated by the short-circuit current in the absence of limiting by the protection device (see example).

### Example

What is the energy limited by a C60N 25 A circuit breaker for a prospective short-circuit current of 10 kA rms. What is the quality of current limiting?

> as shown in the graph opposite:

- this short-circuit current (10 kA rms) is likely to dissipate up to 1,000 kA<sup>2</sup>s
- the C60N circuit breaker reduces this thermal stress to: 43 kA<sup>2</sup>s, which is 23 times less.

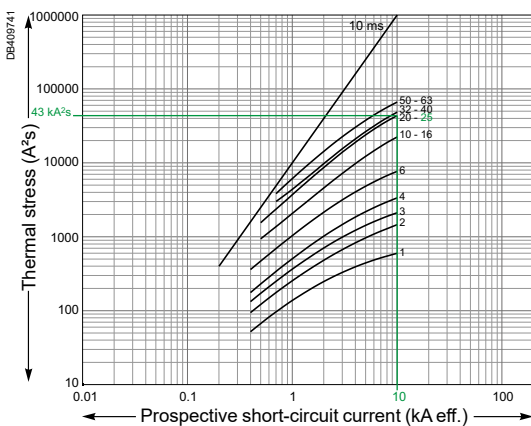

C60N Thermal stress (380-415 V AC)

### Example of use: Stresses acceptable by the cables

The following table shows the thermal stresses acceptable by the cables depending on their insulation, their composition (Cu or Al) and their cross section. Cross-section values are expressed in mm<sup>2</sup> and stresses in A<sup>2</sup>s.

| S (mm <sup>2</sup> ) |    | 1.5                    | 2.5                    | 4                      | 6                      | 10                     |
|----------------------|----|------------------------|------------------------|------------------------|------------------------|------------------------|
| PVC                  | Cu | 2.97 x 10 <sup>4</sup> | 8.26 x 10 <sup>4</sup> | 2.12 x 10 <sup>5</sup> | 4.76 x 10 <sup>5</sup> | 1.32 x 10 <sup>6</sup> |
|                      | Al |                        |                        |                        |                        | 5.41 x 10 <sup>5</sup> |
| PRC                  | Cu | 4.10 x 10 <sup>4</sup> | 1.39 x 10 <sup>5</sup> | 2.92 x 10 <sup>5</sup> | 6.56 x 10 <sup>5</sup> | 1.82 x 10 <sup>6</sup> |
|                      | Al |                        |                        |                        |                        | 7.52 x 10 <sup>5</sup> |

| S (mm <sup>2</sup> ) |    | 16                     | 25                     | 35                     | 50                     |
|----------------------|----|------------------------|------------------------|------------------------|------------------------|
| PVC                  | Cu | 3.4 x 10 <sup>6</sup>  | 8.26 x 10 <sup>6</sup> | 1.62 x 10 <sup>7</sup> | 3.21 x 10 <sup>7</sup> |
|                      | Al | 1.39 x 10 <sup>6</sup> | 3.38 x 10 <sup>6</sup> | 6.64 x 10 <sup>6</sup> | 1.35 x 10 <sup>7</sup> |
| PRC                  | Cu | 4.69 x 10 <sup>6</sup> | 1.39 x 10 <sup>7</sup> | 2.23 x 10 <sup>7</sup> | 4.56 x 10 <sup>7</sup> |
|                      | Al | 1.93 x 10 <sup>6</sup> | 4.70 x 10 <sup>6</sup> | 9.23 x 10 <sup>6</sup> | 1.88 x 10 <sup>7</sup> |

### Example

Is a Cu/PRC cable of cross section 6 mm<sup>2</sup> protected by a C60N 40 A device?

The above table shows that the acceptable stress is 6.56 x 10<sup>5</sup> A<sup>2</sup>s. Any short-circuit current at the point where a C60N 40 A device (I<sub>cu</sub> = 25 kA) is installed will be limited, with a thermal stress of less than 5.7 x 10<sup>5</sup> A<sup>2</sup>s.

The cable is therefore always protected up to the breaking capacity of the circuit breaker.

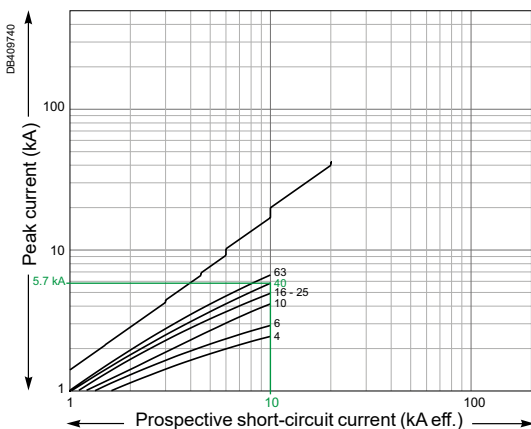

C60N Peak current (380-415 V AC)

**Limitation curves for network**

**Ue: 380-415 V AC (Ph/N 220-240 V AC)**

**C60BP, C60BPR, C60SP**

1P / 2P / 3P

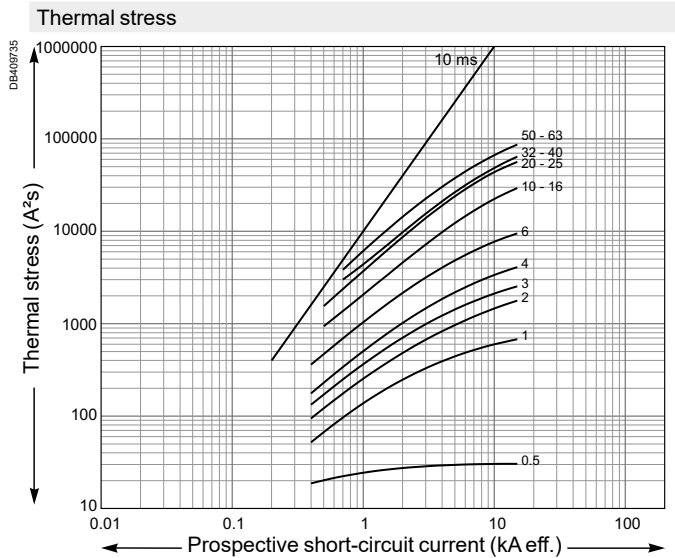
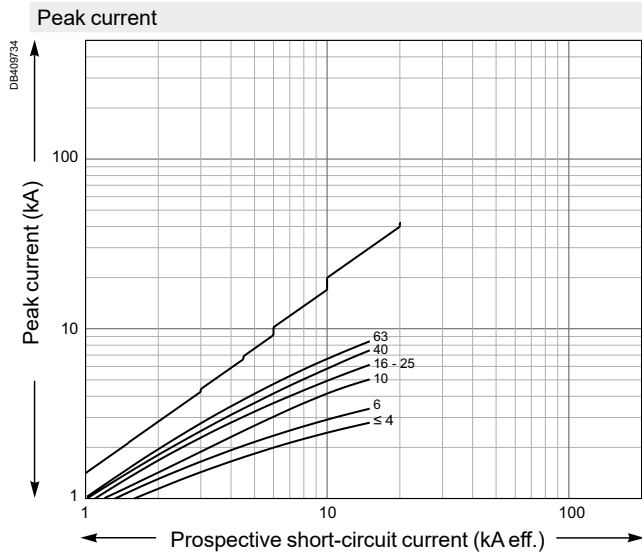

**C60N**

1P / 2P / 3P / 4P

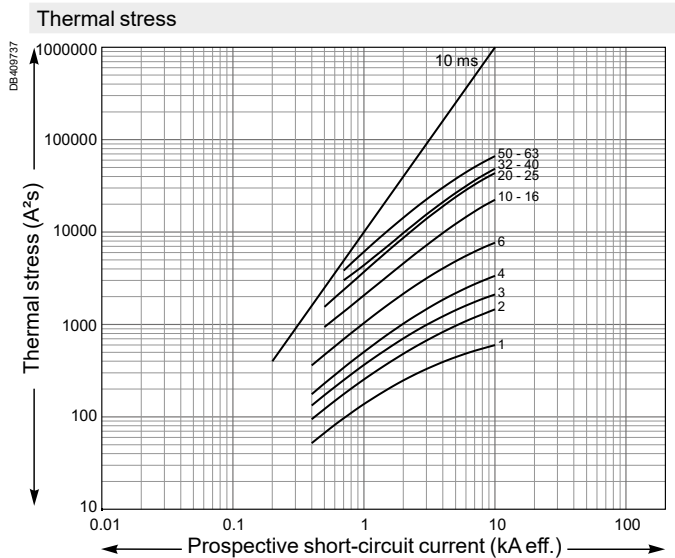
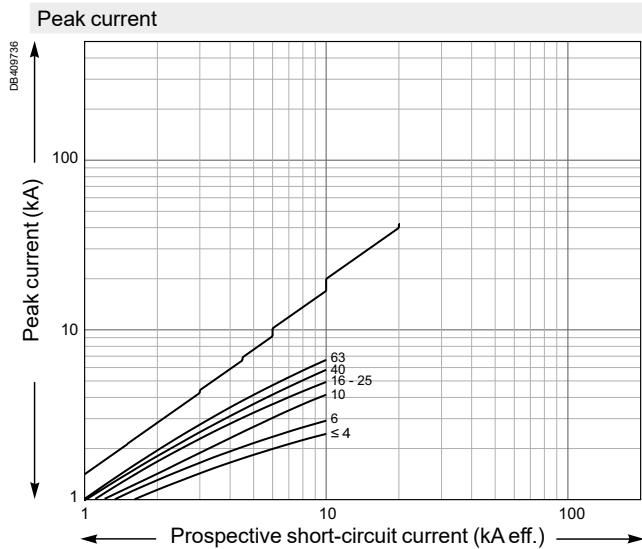

**Limitation curves for network**

**Ue: 380-415 V AC (Ph/N 220-240 V AC)**

**C60H**

1P / 2P / 3P / 4P

Peak current

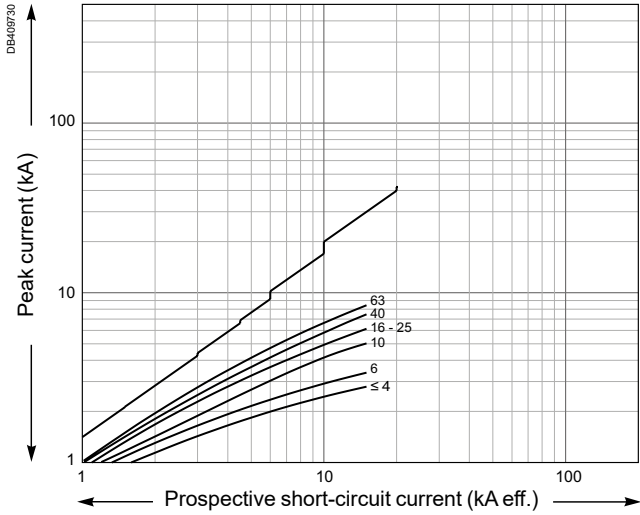

Thermal stress

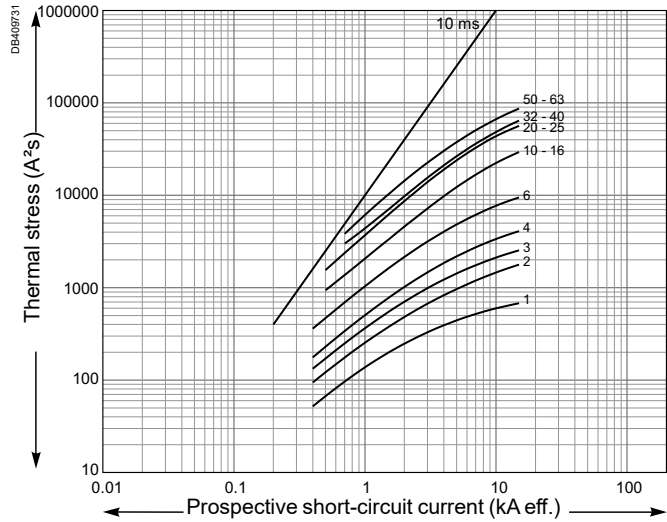

**C60L**

1P / 2P / 3P / 4P

Peak current

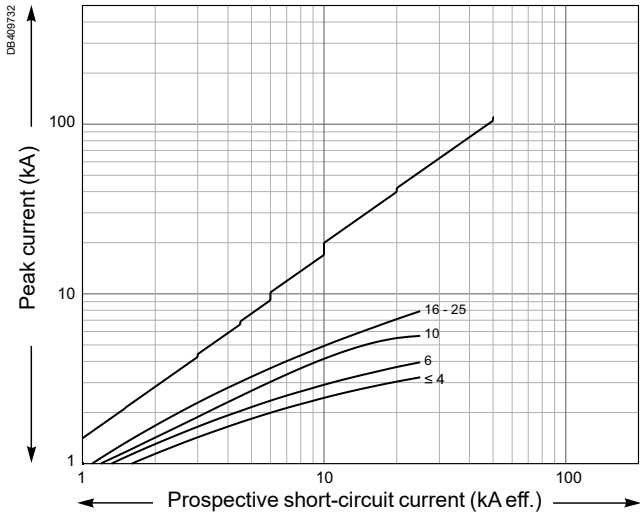

Thermal stress

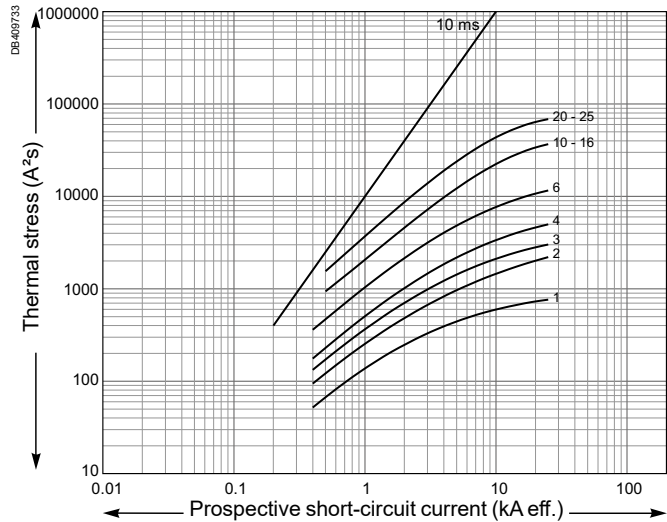

**Limitation curves for network**

**U<sub>e</sub>: 380-415 V AC (Ph/N 220-240 V AC)**

**N40N, N40 Vigi**

**1P+N / 3P+N**

Peak current

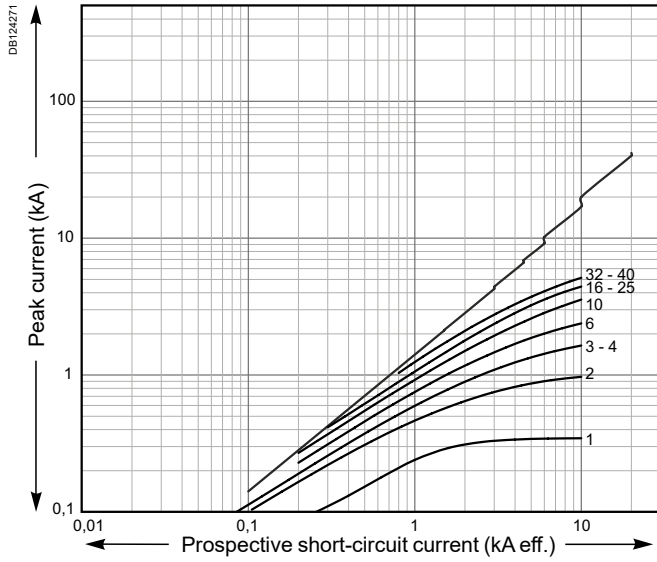

Thermal stress

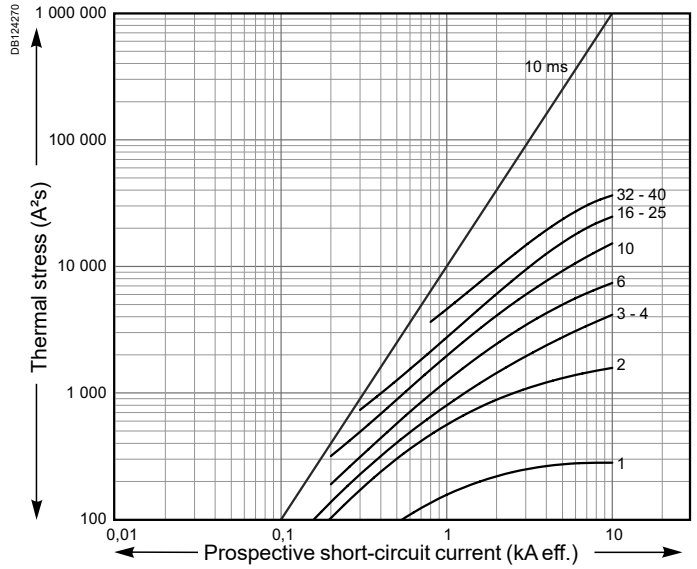

**Limitation curves for network**  
**Ue: 480 V AC 60 Hz (Ph/N 277 V AC)**

**C60BP, C60BPR**

**1P / 2P / 3P**

Peak current

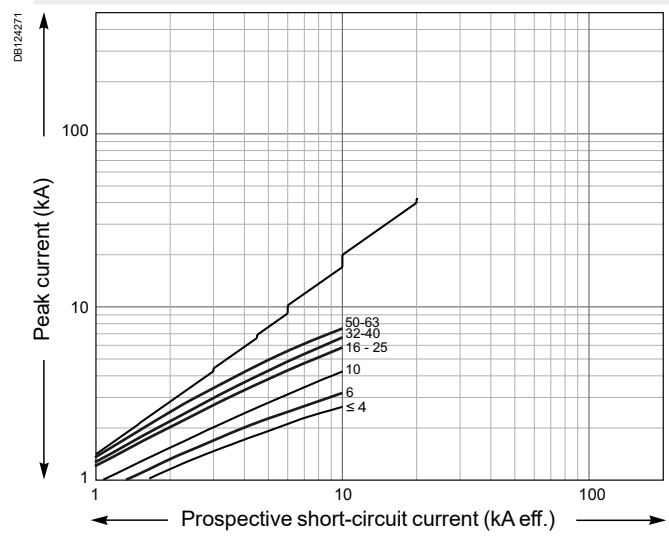

Thermal stress

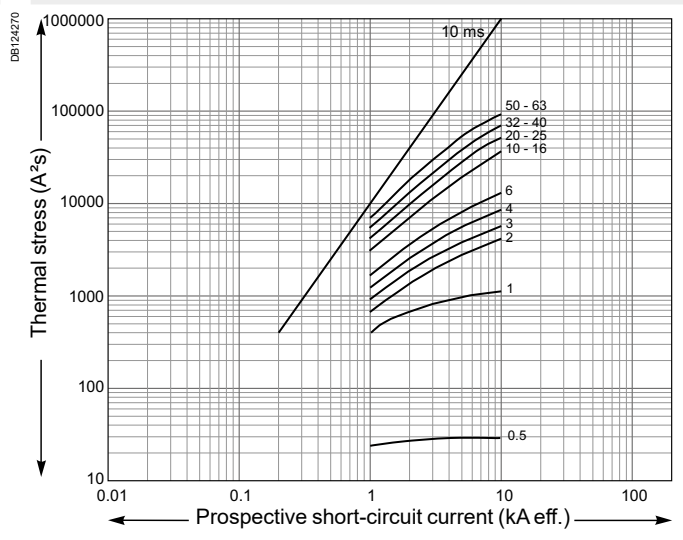



Limitation curves for direct current network

C60H-DC C curve

1P (250 V DC) - 2P (500 V DC)

Peak current

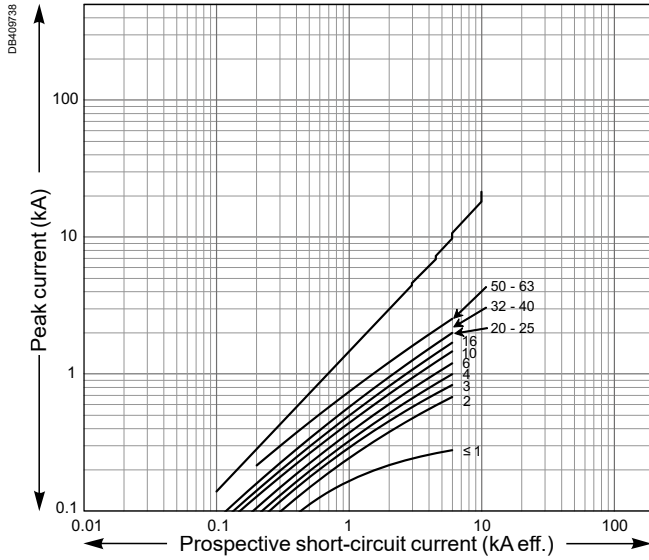

Thermal stress

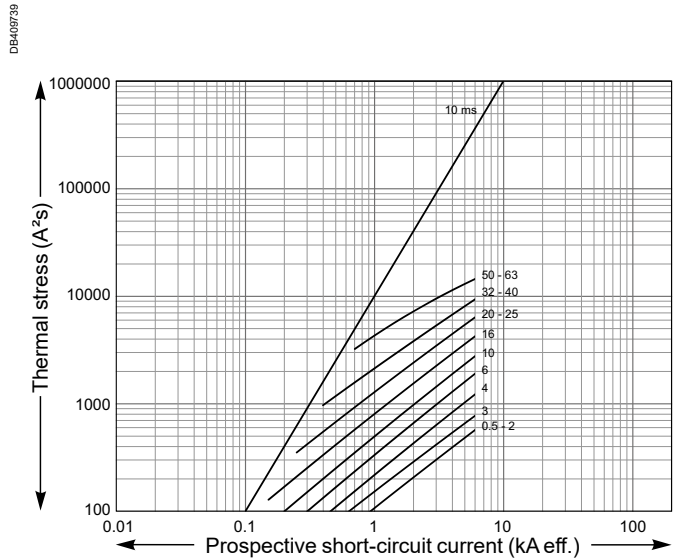



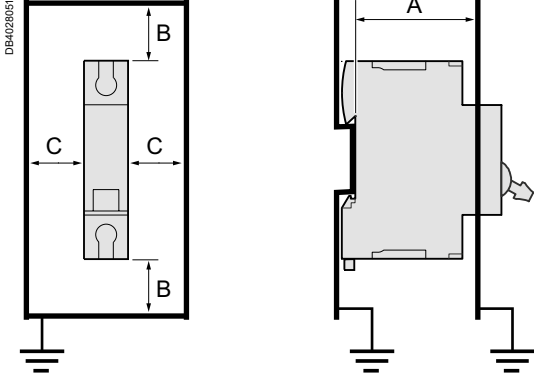

**Minimum clearance between device and bare sheet metal (mm / inches)**



| UL/IEC/GB standards |                 |                 |                   |                              |
|---------------------|-----------------|-----------------|-------------------|------------------------------|
| Products            | C60BP           | C60BPR          | C60SP,<br>C60H-DC | C60N, C60H, C60L,<br>C60CTRL |
| A                   | 52 mm (2.05 in) | 52 mm (2.05 in) | 50 mm (1.97 in)   | 50 mm (1.97 in)              |
| B                   | 10 mm (0.39 in) | 10 mm (0.39 in) | 20 mm (0.79 in)   | 20 mm (0.79 in)              |
| C                   | 10 mm (0.39 in) | 10 mm (0.39 in) | 10 mm (0.39 in)   | 10 mm (0.39 in)              |

Details of minimum distances between the product and earthed metal parts for device intended for use without enclosure.

### Connection

| Products                             | Rating | Copper Multi-cables  |   |   | Cable stripping length  |
|--------------------------------------|--------|--|---|---|---|
|                                      |        | Rigid  | Flexible without ferrule  | Flexible with ferrule   |   |
|                                      |        |               |  |  |  |
| <b>C60BP</b><br>UL489                | ≤25A   | 2x1.5 mm <sup>2</sup> or 2x2.5 mm <sup>2</sup> or 2x1.5 mm <sup>2</sup> +1x2.5 mm <sup>2</sup> |   | 2xAWG #16 or 2xAWG #14 or 2xAWG #16+1xAWG #14                                       | 14 mm / 0.55 in   |
|                                      | >25A   | 2x4 mm <sup>2</sup> or 2x6 mm <sup>2</sup> or 2x1.5 mm <sup>2</sup> +1x2.5 mm <sup>2</sup>     |   | 2xAWG #12 or 2xAWG #10 or 2xAWG #16+1xAWG #14                                       | 14 mm / 0.55 in   |
| <b>C60SP</b><br>UL1077               | ≤25A   | 2x1.5 mm <sup>2</sup> or 2x2.5 mm <sup>2</sup> or 2x1.5 mm <sup>2</sup> +1x2.5 mm <sup>2</sup> |   | 2xAWG #16 or 2xAWG #14 or 2xAWG #16+1xAWG #14                                       | 14 mm / 0.55 in   |
|                                      | >25A   | 2x4 mm <sup>2</sup> or 2x6 mm <sup>2</sup> or 2x1.5 mm <sup>2</sup> +1x2.5 mm <sup>2</sup>     |   | 2xAWG #12 or 2xAWG #10 or 2xAWG #16+1xAWG #14                                       | 14 mm / 0.55 in   |
| <b>C60H-DC</b>                       | ≤25A   | 2x1.5 mm <sup>2</sup> or 2x2.5 mm <sup>2</sup> or 2x1.5 mm <sup>2</sup> +1x2.5 mm <sup>2</sup> |   | 2xAWG #16 or 2xAWG #14 or 2xAWG #16+1xAWG #14                                       | 14 mm / 0.55 in   |
|                                      | >25A   | 2x4 mm <sup>2</sup> or 2x6 mm <sup>2</sup> or 2x1.5 mm <sup>2</sup> +1x2.5 mm <sup>2</sup>     |   | 2xAWG #12 or 2xAWG #10 or 2xAWG #16+1xAWG #14                                       | 14 mm / 0.55 in   |
| <b>C60N, H, L,</b><br><b>C60CTRL</b> | ≤25A   | 2x1.5 mm <sup>2</sup> or 2x2.5 mm <sup>2</sup> or 2x1.5 mm <sup>2</sup> +1x2.5 mm <sup>2</sup> |   | 2xAWG #16 or 2xAWG #14 or 2xAWG #16+1xAWG #14                                       | 14 mm / 0.55 in   |
|                                      | >25A   | 2x4 mm <sup>2</sup> or 2x6 mm <sup>2</sup> or 2x1.5 mm <sup>2</sup> +1x2.5 mm <sup>2</sup>     |   | 2xAWG #12 or 2xAWG #10 or 2xAWG #16+1xAWG #14                                       | 14 mm / 0.55 in   |
| <b>N40N</b>                          | All    | 2x1.5 mm <sup>2</sup> or 2x2.5 mm <sup>2</sup> or 2x1.5 mm <sup>2</sup> +1x2.5 mm <sup>2</sup> |   | 2xAWG #16 or 2xAWG #14 or 2xAWG #16+1xAWG #14                                       | 13 mm / 0.5 in  |
| <b>GFP</b><br>UL1053                 | All    | 2x 1.5 mm <sup>2</sup> to 10 mm <sup>2</sup>   |   | 2x AWG #16 to #8  | 14 mm / 0.55 in   |
| <b>RCCB ID</b><br>IEC/EN 61008-1     | All    | 2x 1.5 mm <sup>2</sup> to 10 mm <sup>2</sup>   |   | 2x AWG #16 to #8  | 14 mm / 0.55 in   |
| <b>RCCB-ID 125A</b>                  | All    | 2x 1.5 mm <sup>2</sup> to 16 mm <sup>2</sup>   |   | 2x AWG #16 to #6  | 11 mm / 0.43 in   |
| <b>Vigi C60</b>                      | All    | 2x4 mm <sup>2</sup> or 2x6 mm <sup>2</sup> or 2x1.5 mm <sup>2</sup> +1x2.5 mm <sup>2</sup>     |   | 2xAWG #12 or 2xAWG #10 or 2xAWG #16+1xAWG #14                                       | 14 mm / 0.55 in   |
| <b>Vigi N40</b>                      | All    | 2x1.5 mm <sup>2</sup> or 2x2.5 mm <sup>2</sup> or 2x1.5 mm <sup>2</sup> +1x2.5 mm <sup>2</sup> |   | 2xAWG #16 or 2xAWG #14 or 2xAWG #16+1xAWG #14                                       | 13 mm / 0.5 in  |
| <b>N40 Vigi</b>                      | All    | 2x1.5 mm <sup>2</sup> or 2x2.5 mm <sup>2</sup> or 2x1.5mm <sup>2</sup> +1x2.5 mm <sup>2</sup>  |   | 2xAWG #16 or 2xAWG #14 or 2xAWG #16+1xAWG #14                                       | 13 mm / 0.5 in  |



Discover our technical guides collection.

They are dedicated to frequent issues faced when designing an installing a control panel.

How to reduce damage to components through effective thermal management inside an enclosure

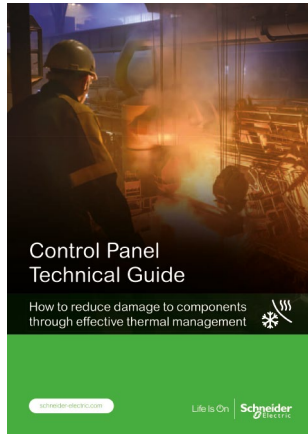

Ref.: CPTG001\_EN



Click on QR code or scan to download

How to prevent machine malfunctions and electronic damage due to voltage surges

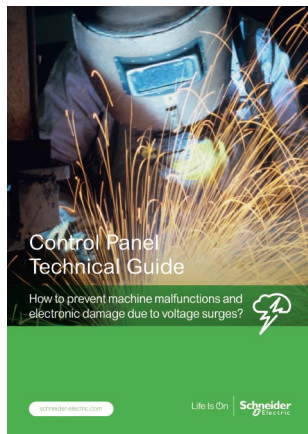

Ref.: CPTG002\_EN



Click on QR code or scan to download

How to ensure trouble-free approval of your UL-compliant control panels

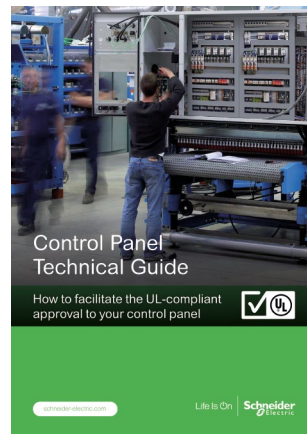

Ref.: CPTG005\_EN



Click on QR code or scan to download



Discover our technical guides collection.

They are dedicated to frequent issues faced when designing an installing a control panel.

How define the right outdoor enclosure and optimize its durability



Ref.: CPTG006\_EN



Click on QR code or scan to download

How to choose the circuit breaker and transfer switch for a generator set

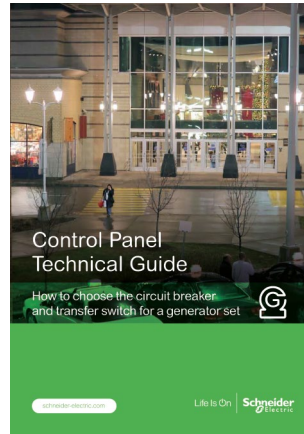

Ref.: CPTG008\_EN



Click on QR code or scan to download

How to select the appropriate motor starters for your HVAC equipments



Ref.: CPTG007\_EN



Click on QR code or scan to download

How to prevent condensation inside an enclosure



Ref.: UE12MK03EN



Click on QR code or scan to download

Discover our technical guides collection.

They are dedicated to frequent issues faced when designing an installing a control panel.

How to choose the contactors for elevator machinery?

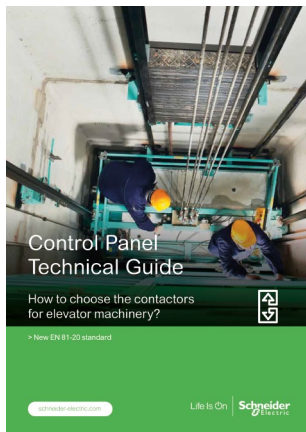

Ref.: CPTG009\_EN



Click on QR code or scan to download

How to select the appropriate motor control system for your pump

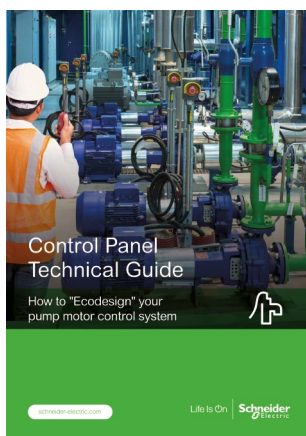

Ref.: CPTG010\_EN



Click on QR code or scan to download

Life Is On | **Schneider**  
Electric

**Schneider Electric Industries SAS**

35, rue Joseph Monier  
CS 30323  
92506 Rueil Malmaison Cedex  
France

12-2021  
LVCATM9OEM\_EN