

 **masdaf**

*Fire pumps and
pump groups*



World standard Masdaf quality



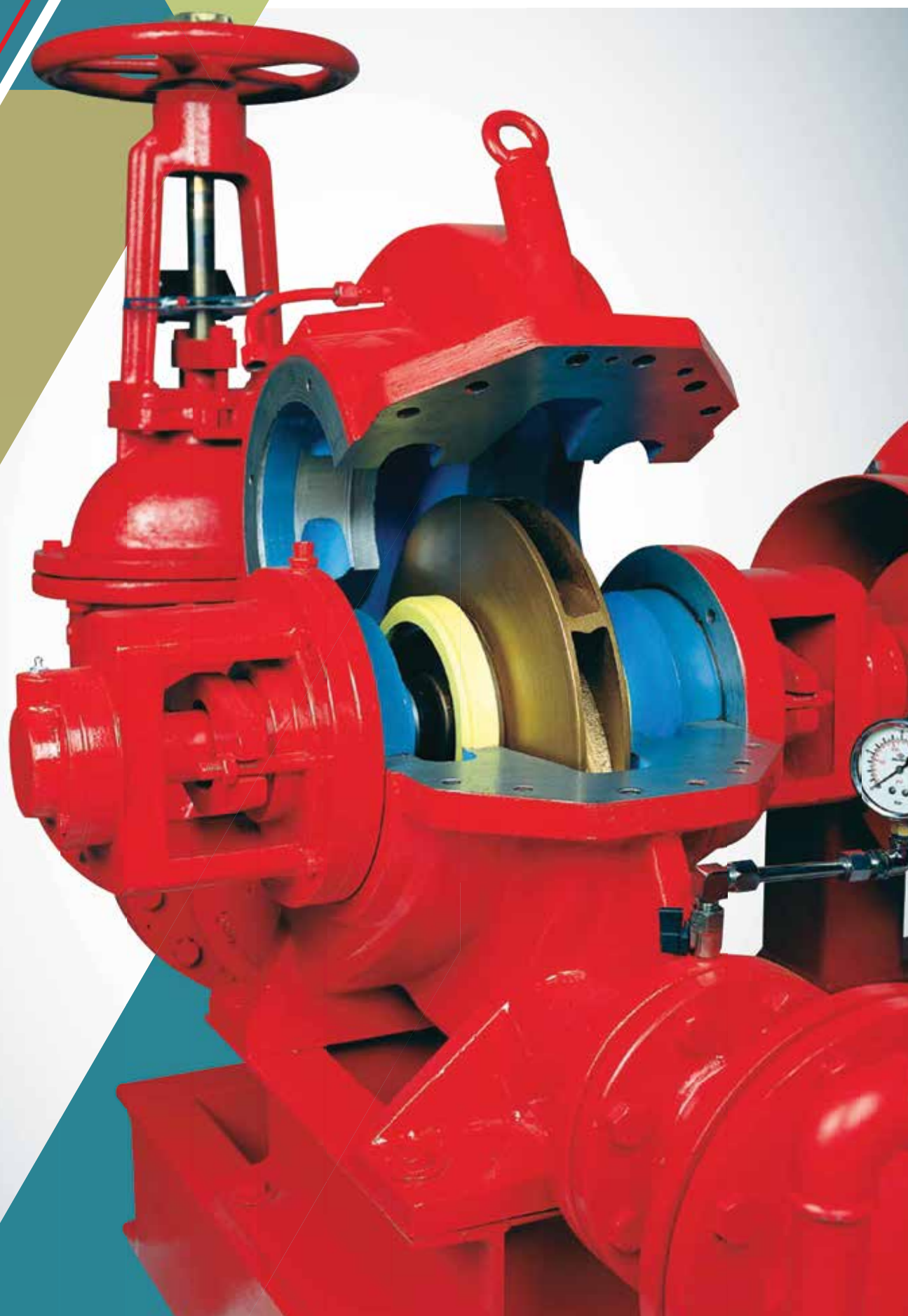

What is UL and FM?



What is UL?

Underwrites Laboratories is an independent certification casing that sets standards on product safety and tests the safety of products under these standards. UL certifies over 19000 products. More than 20 million UL branded products of 7200 manufacturers are used annually in the world. UL offers its customers test and certification services with its 64 test laboratories in 98 countries. UL has standards in many areas such as building materials, food, lighting and fire systems, etc.

UL has been working on testing and reliability of products for 100 years. UL testing and certification services offer advantages for manufacturers and users for fire prevention systems. There is UL product guide on the site. This guide contains a list of companies authorized to use UL, and the documentation contains important information for regulatory agencies, building owners and insurance companies.

What is FM?

FM (Factory Mutual) is an independent technical institution that provides performance approval for the materials and systems of FMI (Factory Mutual Insurance), which insures private and large risks.

FM approval in fire pumps is given by taking the NFPA 20 requirements into account. However, as some requirements beyond NFPA 20 are also sought, FM approval is known as the highest grade product quality approval that has the most difficult conditions among the quality approvals given to fire pumps and environmental elements

UL Listed/FM Approved at Masdaf

Masdaf became the first UL listed and FM approved local manufacturer by applying to UL and FM for the fire pumps as the first local pump manufacturer of Turkey since 1977. Offered end-suction and horizontally split case fire pumps, which have been designed according UL 448 "Centrifugal Stationary Pumps for Fire-Protection Service", FM 1319 "Approval Standard for Centrifugal Fire Pumps (Horizontal, End Suction Type) and FM/ 131T Approval Standard for Centrifugal Fire Pumps (Axial or Radial Split-Case Type) standards, to its customers.

Specifications of fire pumps

What are the design requirements of fire pumps per UL 448, FM 1319 and FM 1311?

It is a standard containing the designing and testing process of UL 448 end-suction, double suction and hot type pumps. UL and FM approval can be obtained for fire pumps for certain flow rates. You can see the values in the table on the side.

Flow range			
gpm	l/m	gpm	l/m
25	(95)	1000	(3785)
50	(189)	1250	(4731)
100	(379)	1500	(5677)
150	(568)	2000	(7570)
200	(757)	2500	(9462)
250	(946)	3000	(11355)
300	(1136)	3500	(13247)
400	(1514)	4000	(15140)
450	(1703)	4500	(17032)
500	(1892)	5000	(18925)
750	(2839)		

The impeller, impellerwear ring, impellernut, casing wear ring, lantern ring, gland, gland nut, gland bolt, shaft bushing, pump bolts and setscrews must be made of corrosion resistant material. There must be a pump label on the bearing permanently mounted on the pump (casing or bearing). This label must be manufactured as corrosion resistant. There must be drain plug on the casing. Its material must be made of rust-resistant material and at minimum 1/2" size. The pump must have gland packing and packing box. Rolling bearings must have a operating life of 5000 hours at maximum load.

What are the performance requirements of fire pumps per UL 448, FM 1319 and FM 1311?

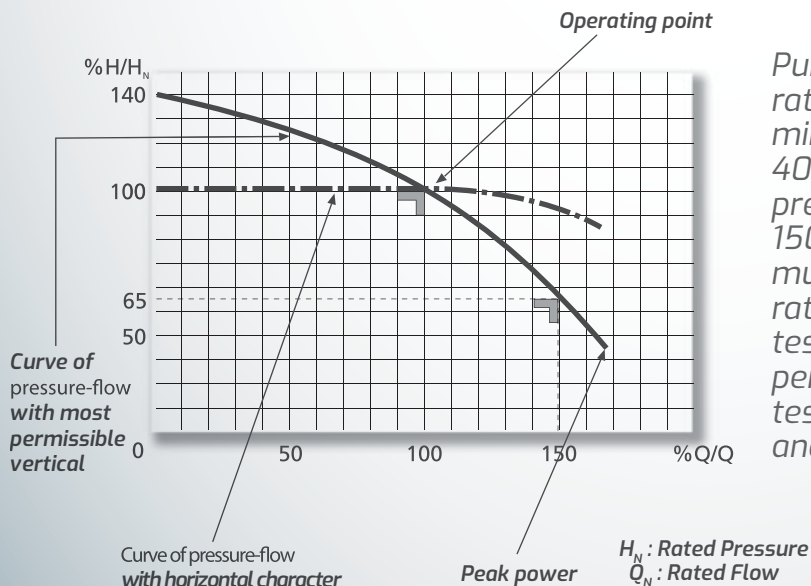

Pumps must be at the nominal flow rate provided in the table and the minimum pump pressure must be 40 psi (276 kPo = 2.76 Bar). The pressure produced by the pump at 150% of the rated flow rate of test must not be less than 65% of the rated pressure. The pump shall be tested at rated engine speeds. The performance curves include the tests on closed valve, rated flow rate and 150% of the nominal flow rate.



What is NFPA?

NFPA (National Fire Protection Association) is the American Fire Protection Association of which our company is a member too. This association is an institution that sets and publishes the standards of the matters that affect the fire and safety, which must be implemented in the USA, and starts the implementation. Compared to similar standard institutions of other countries, including our country, it is the most referenced, respected and applied standard in the world. Masdaf Fire Pumps Series pumps are manufactured in accordance with the relevant standards of NFPA for two important reasons.

- NFPA is the standard that is the most widely used in the world and has the heaviest conditions particularly in pump systems.
- In our country, almost all technological systems, particularly automatic fire sprinklers, indoor fire cabinets and hydrant fire extinguishing systems such as outdoor hydrant system, are designed according to NFPA standards. In terms of integrity, as a general rule, the performance specifications of the products to be used in that system must be in compliance with the same standard to which the system is designed per. Otherwise, incompatibility between the design and the product is inevitable. Since MAS YPSP, YNM and YPH Series pumps are compatible with NFPA, they can be used in full compliance with water fire extinguishing systems (automatic sprinklers, indoor fire cabinet, outdoor hydrant, overflow spray and foam systems) designed according to NFPA standards.

What is NFPA 20?

NFPA 20 (Standard for the Installation of Centrifugal Fire Pumps) is NFPA's standard for fire pumps; and it is the standard that determines the specifications, performances and assembly rules of fire pumps and pump groups, engine control systems and auxiliary elements that must be used.

Specifications of fire pumps

What are the specifications of fire pumps per NFPA 20?

NFPA; due to the special importance of fire pumps, has set a standard for both material specifications and performance specifications. The compliance of a fire pump with NFPA 20 requires the fulfilment of these requirements. When these specifications are examined, it is seen that there is a very serious difference between general purpose pumps and fire pumps. The fire pumps; throughout their operating life; are designed to provide maximum reliability and net outlet pressure value. The design criterion in general purpose pumps is the maximum efficiency and economic operation feature.

Listed fire pumps; are available for rated flow rates between 100-8000 gpm. The nominal pressure values are given as 30-262 psi (20 mss-185 mss) for horizontal shaft pumps, 26-510 psi (18m55-358m55) for vertical shaft pumps.

Listed centrifugal pumps; are classified as horizontal shaft end suction, In-line type, horizontally separable casing and vertical shaft turbine type.

Listed Pump Types Pressure and Flow Ranges				
Pump Type	Pressure		Flow	
	psi	mSS	gpm	m3/h
End-suction with horizontal shaft	58-203	40-140	50-1250	11-284
In-Line type	43-164	30-115	50-750	11-170
Horizontally split case	30-262	20-185	100-8000	22-1800
Turbine with vertical shaft	25-510	18-358	250-5000	56-1135

Material specifications of fire pumps per NFPA 20

Pump Casing: Pump casing material must be GG 25 grey cast iron or GGG40 nodular cast iron according to the pressure class.

Pump Impeller: According to NFPA 20, UL 448, FM, the fire pump impeller must be made of Bronze or stainless steel cast material. As in general purpose pumps, the impeller made of grey cast iron material is never used.

Pump Shaft: The pump shaft must be made of AISI316 stainless steel material. Furthermore, FM and UL 448 standards brought strict design rules for the shafts to be used in fire pumps.

Sealing: It must be provided with a gland packing and the packing bearing must be designed to receive at least five lines of packing.

Bearing housing: The bearings must be grease lubricated roller bearings. The bearings used must be selected to operate at least 5000 hours smoothly at maximum load.

Basic Materials Per NFPA 20	
Pump casing	GG25/GGG 40
Impeller	Bronze or Stainless Steel
Shaft	AISI 316 (FM-UL 448)
Wear ring	Bronze
Gland	Bronze
Lantern ring	Bronze
Sealing	Gland Packing
Bearing Housing	Rolling bearing

Performance specifications of fire pumps according to NFPA 20

According to NFPA 20, the characteristic curve of the fire pumps is determined by 3 points:

Shut-off Discharge Pressure: The shut-off discharge pressure of the pump (closed valve status at zero flow rate) must not be more than 140% of the rated pressure.

Rated Value: The pump characteristic curve must pass rated flow and rated pressure at or above the point intersection or this point.

Maximum Load (Overload): The pump must be able to operate at 150% of the rated flow, if required. Must provide a pressure of 150% of the rated flow, at least 65% of the rated pressure.

- *Water speed is very important in fire pumps and water speed must not be more than 3m/sec in nominal flow rate according to NFPA 20. In the designed system, the diameter of the pipes must be selected according to this value.*
- *All measurements and calculations must be done for clean water at +20°C.*
- *Engine powers; must be determined in accordance with the operating conditions including 150% of the nominal flow rate.*
- *The manufacturer must conduct an aqueous test for each pump to demonstrate that the pump provides the specified performance, and a certificate indicating the test results must be issued. This certificate must contain pressure-flow, shaft power and efficiency curves.*
- *The fire pumps (except Vertical Shaft Turbine Type) must not be operated in a way to make suction.*
- *On each pump; there must be a metal label indicating the rated pressure flow and speed values.*
- *All pumps must be equipped with pressure gauges (pressure gauge, vacuum meter) that display the suction and discharge pressure and installed on the pump suction-discharge flange centre.*
- *All pumps must be equipped with casing relief valve that will provide casing cooling under shut-off discharge pressure.*
- *The pump-engine coupling and other movable elements must be closed with protection caps.*

End-Suction Centrifugal Fire Pumps

Areas of Use

In fire extinguishing systems;

- Hospitals
- Offices
- Airports
- Factories
- Schools
- Pharmaceutical Plants
- Warehouses
- Industrial Plants

Pumped Liquids

It is used in pumping clean and sea water that do not contain solid particles.

Design

- They are single-stage and end-suction volute casing centrifugal pumps.
- Pump performances comply with NFPA standards.
- The single inlet shut-off impeller has been balanced with balance holes and wear rings against axial load and has been dynamically balanced.
- The pump and engine have been connected via a flexible coupling and the unit has been fixed on a common base plate.
- The pump is very easy to maintain and during the maintenance process, the impeller, shafts and other rotating elements can be removed without uninstalled from the pump installation.

Bearing Housing

Maintenance-free self-lubricating bearings have been used as pump bearing elements.

Sealing

Gland packing is preferred in fire groups with shaft sealing certificate.



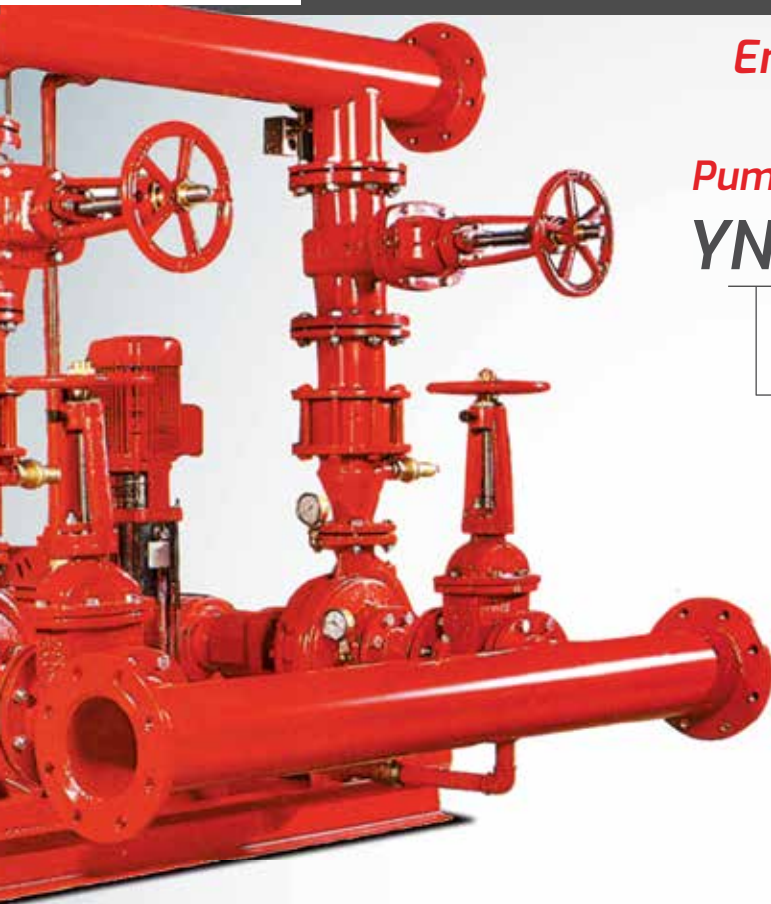

End-Suction Centrifugal Fire Pumps

Pump Naming

YNM 100-250

Nominal impeller diameter (mm)

Discharge flange DN (mm)

Pump type

Technical Specifications

Suction flange	DN65/DN125
Discharge flange	DN40/DN100
Flow	11-227 m ³ /h
Discharge pressure	30-140mt

Material Specifications

Casing	GG25 / GGG 40 / Bronze stainless steel
Impeller	Bronze or stainless steel
Shaft	AISI 316
Sealing	Gland packing
Bearing Housing	Rolling bearing
Suction/discharge flanges	PN16 (DIN 2533)

Driver Options



Electrical



Diesel

Application Areas



Fire Cabinet



Hydrant



Sprinkler



Overflow



Foam

Hazard Class



Mild



Ordinary



High

End-Suction Centrifugal Fire Pumps

Pump Sizes

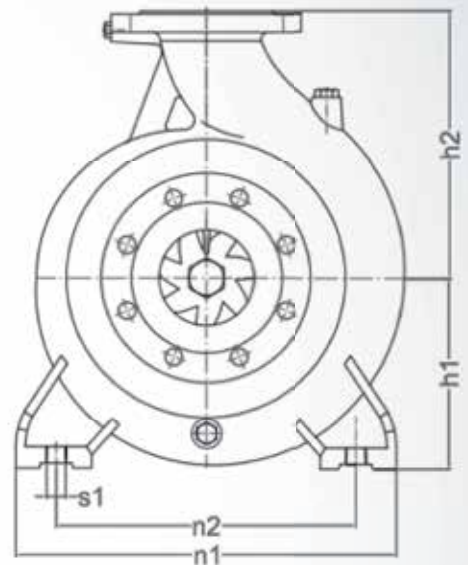
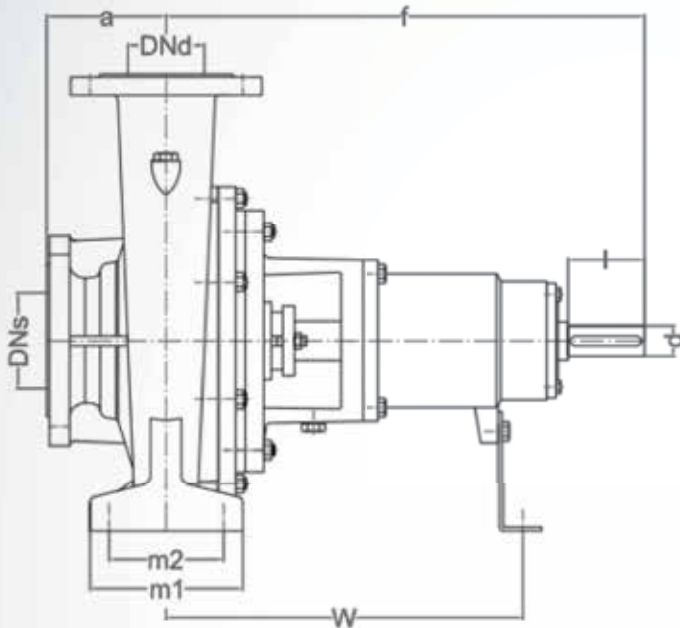

General Pump Sizes

Pump Type	Pump Sizes (mm)						Foot Dimensions (mm)						Shaft Outlet		
	DNs	DNd	a	f	h1	h2	b	m1	m2	n1	n2	s1	w	d	l
YNM 32-200	50	32	80	360	160	180	50	100	70	240	190	M12	260	24	50
YNM 32-250	50	32	100	360	180	225	50	125	95	320	250	12	260	24	50
YNM 40-250	65	40	100	500	180	225	65	125	95	320	250	12	370	32	80
YNM 50-250	65	50	125	500	180	225	65	125	95	320	250	12	370	32	80
YNM 50-315	80	50	100	470	225	280	80	160	120	360	280	16	330	32	80
YNM 65-250	80	65	125	500	200	250	80	160	120	360	280	76	370	32	80
YNM 65-315	80	65	125	470	225	280	80	160	120	400	315	76	340	32	80
YNM 80-250	100	80	125	500	200	280	80	160	120	400	315	76	370	32	80
YNM 80-315	100	80	125	470	250	315	80	160	120	400	315	76	340	32	80
YNM 100-250	125	100	140	470	225	280	80	160	120	400	315	76	340	32	80

End-Suction Centrifugal Fire Pumps

YNM Series Fire Pumps Selection Table

Pump Type	Dimension	Flow Range	Pressure Range	Pressure Range	Rotation Speed	Max. Operating Pressure
	DNs-DNd	GPM	psi	bar	rpm	bar
YNM 32-250	50-32	50-100	58-145	4-10	2900	16
YNM 40-250	65-40	100-200	87-159	6-11	2900	16
YNM 50-250	65-50	150-300	87-159	6-11	2900	16
YNM 50-315	80-50	150-300	101-188	7-13	2900	16
YNM 65-250	80-65	300-500	72-159	5-11	2900	16
YNM 65-315	80-65	300-500	101-203	7-14	2900	16
YNM 80-250	100-80	400-750	87-159	6-11	2900	16
YNM 80-315	100-80	500-1000	116-188	8-13	2900	16
YNM 100-250	125-100	500-1000	87-145	6-10	2900	16

Hydraulic Range

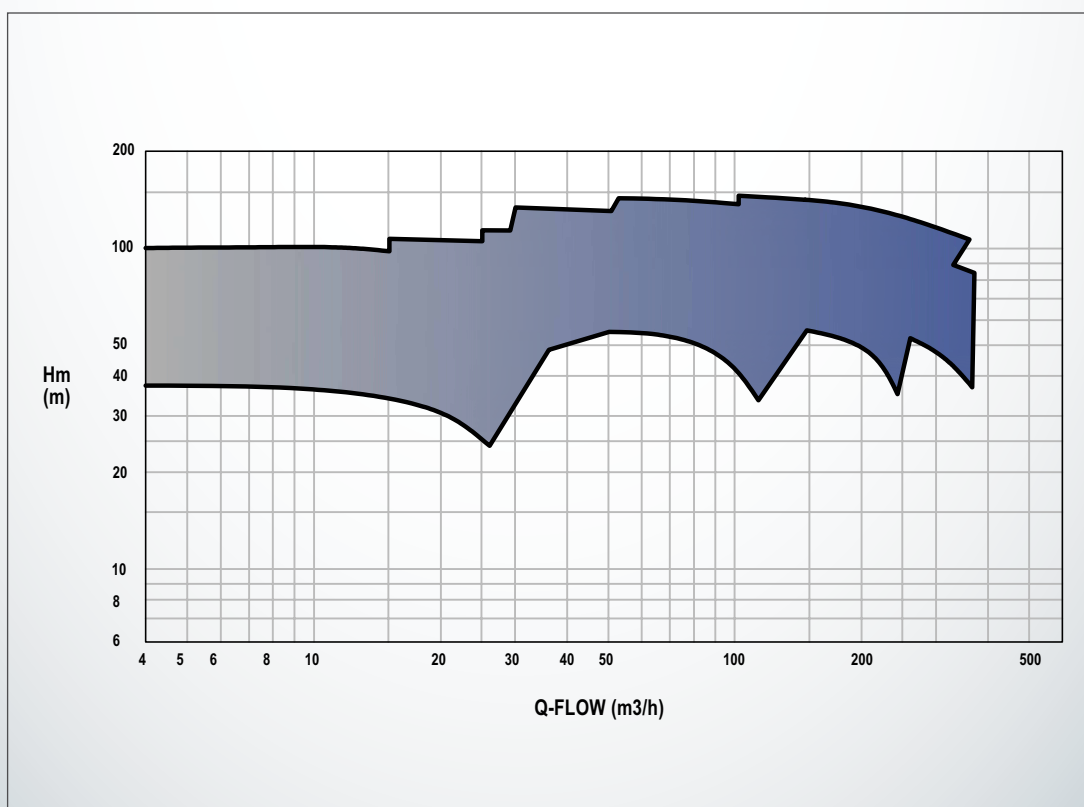

End-Suction Centrifugal Fire Pumps

Areas of Use

In fire extinguishing systems;

- Hospitals
- Offices
- Airports
- Factories
- Schools
- Pharmaceutical Plants
- Warehouses
- Industrial Plants



Design

- YNM series UL Listed/FM Approved pumps are single-stage, non-self-suction, end-suction centrifugal pumps.
- With 3 pumps as YNM 525, YNM 825 and YNM 1531, meets the flow range between 50 gpm and 1250 gpm.
- Pump flanges are designed according to ANSI/ASME B16.1 Class 250 norm.
- Pump performance tests meet the requirements of UL and FM standards.
- The single suction, shut-off impeller has been balanced with wear rings at axial load and has been dynamically balanced.
- Shaft sealing is provided with gland gaskets.
- Elements such as bolts, setscrew, etc. in contact with water in the pump are made of corrosion resistant material.

Technical Specifications	
Flow range	50 -1250 gpm (10 - 280 m3/h)
Man. pressure range	80-155psi(55-110m)
Operating pressure	14 bar
Operating temperature	0-60T
Engine speed range	2900 rpm
Suction flange	3"-8"
Discharge flange	2"-6"

Material Specifications	
Casing	Cast iron
Impeller	Bronze
Shaft	AISI 316
Sealing	Gland packing
Bearing Housing	Rolling bearing
Suction/discharge flanges	ANSI / ASME B16.1

End-Suction Centrifugal Fire Pumps

Driver Options



Electrical



Diesel

Application Areas



Fire Cabinet



Hydrant



Sprinkler



Overflow



Foam

Hazard Class



Mild



Ordinary



High

Pump Sizes

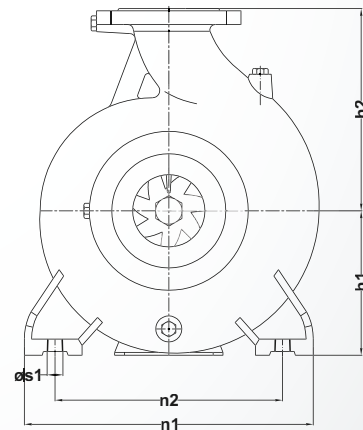
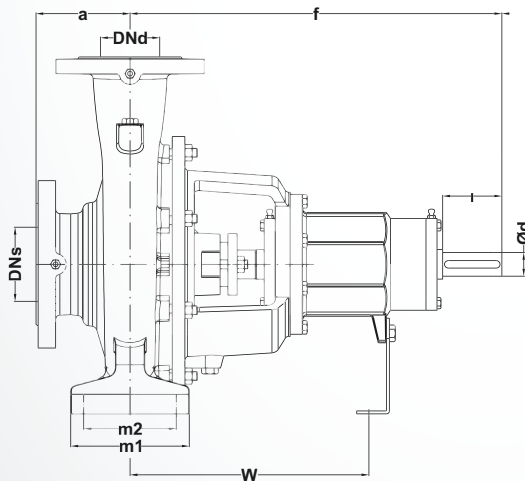

General Pump Sizes

Pump Type	Pump Sizes (mm)						Foot Dimensions (mm)						Shaft Outlet		
	DNs	DNd	a	f	h1	h2	b	m1	m2	n1	n2	s1	w	d	l
YNM 1531	8"	6"	160	530	280	400	100	200	150	550	450	14	355	42	82
YNM 825	5"	3"	125	500	225	280	80	160	120	400	315	14	370	32	87.5
YNM 525	3"	2"	125	500	180	225	65	125	95	320	250	14	370	32	87.5

End-Suction Centrifugal Fire Pumps

YNM UL/FM Pumps Selection Table

YNM UL Listed/FM Approved Fire Pumps Selection Table							
Flow		Dimension	Model Type	Net Pressure Range		Max. Operating Pressure	
GPM	m3/h	inc		psi	m	rpm	psi
50	11	3-2	YNM 525	98-154	69-108	2900	200
100	23	3-2	YNM 525	99-154	70-108	2900	200
150	34	3-2	YNM 525	99-155	70-109	2900	200
200	45	3-2	YNM 525	99-155	70-109	2900	200
250	57	3-2	YNM 525	98-155	69-109	2900	200
300	68	3-2	YNM 525	95-153	67-108	2900	200
300	68	5-3	YNM 825	91-144	64-101	2900	200
400	91	5-3	YNM 825	86-143	60-101	2900	200
450	102	5-3	YNM 825	84-143	59-101	2900	200
500	114	5-3	YNM 825	81-143	57-101	2900	200
500	114	8-6	YNM 1531	115-154	81-108	2900	200
750	170	8-6	YNM 1531	112-153	79-108	2900	200
1000	227	8-6	YNM 1531	108-152	76-107	2900	200
1250	284	8-6	YNM 1531	103-148	72-104	2900	200

Hydraulic Range

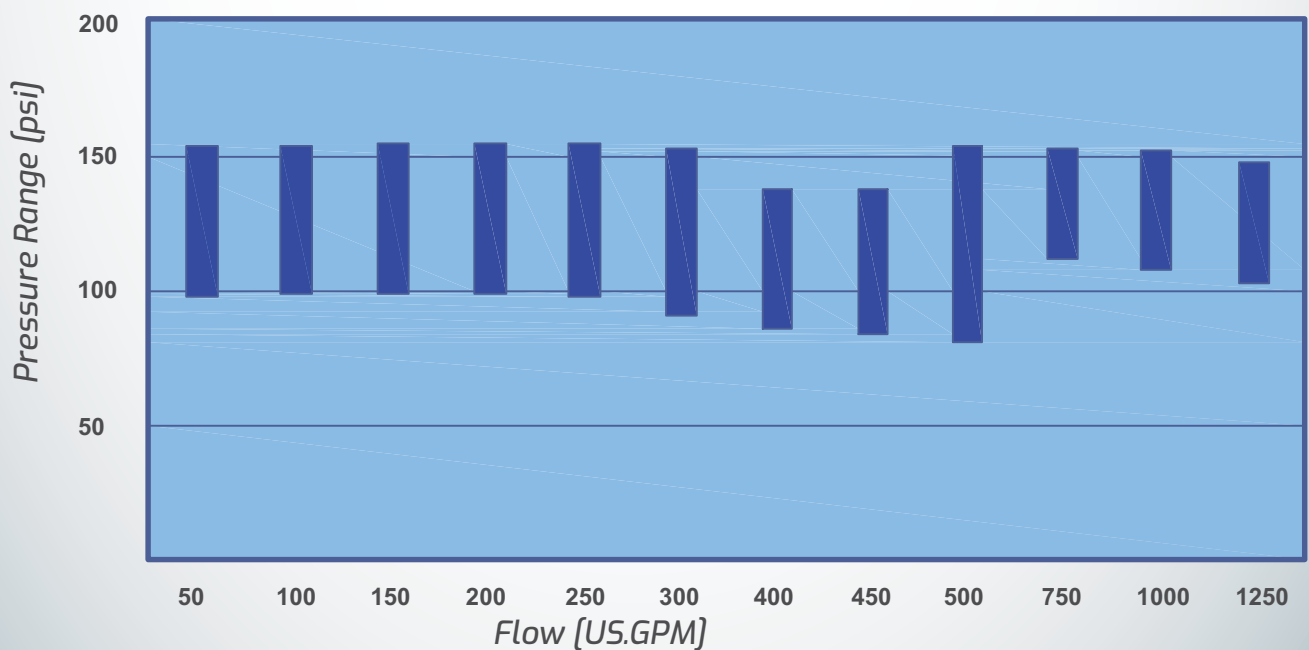

In-line Type Fire Pumps

Areas of Use

In fire extinguishing systems;

- Hospitals
- Airports
- Schools
- Warehouses
- Offices
- Factories
- Pharmaceutical Plants
- Industrial Plants

Pumped Liquids

It is used in pumping clean and sea water that do not contain solid particles and fibre.

Design

- They are single-stage, vertical shaft In-line type volute casing centrifugal pumps.
- Pump performances comply with NFPA standards.
- The single suction, shut-off impeller has been balanced with balance holes and wear rings against axial load and has been dynamically balanced.
- Pump and engine connection is made through an adapter and using a special rigid coupling.
- Since the pump can be separated from the installation as to have its casing remain connected to the installation, maintenance and repair operations can be carried out easily.
- Per NFPA fire standard, the shaft sealing is provided with gland gaskets.
- In the design, the principle that the main part can be replaced has been adopted. Thus, the spare part supply has been accelerated.
- It provides easy direct starting with low electric engine powers.
- It takes up little space with its compact structure.

Sealing

Gland packing is preferred in fire groups with shaft sealing certificate.



In-line Type Fire Pumps

Pump Naming

YPH 100-280

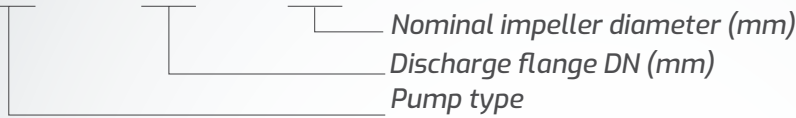

Technical Specifications	
Suction flange	DN65/DN125
Discharge flange	DN40/DN100
Flow	11 - 770 m ³ /h (50-750 gpm)
Discharge pressure	30 -115 m (43-164 psi)

Material Specifications	
Casing	GG25 (PN16)
Impeller	Bronze or stainless steel cast
Shaft	A151316
Sealing	Gland packing
Bearing Housing	Rolling bearing
Suction/discharge flanges	PN16 (DIN 2533)

Driver Options



Electrical

Hazard Class



Mild



Ordinary

Application Areas



Fire



Hydrant



Sprinkler



Overflow



Foam

In-line Type Fire Pumps

Pump Sizes

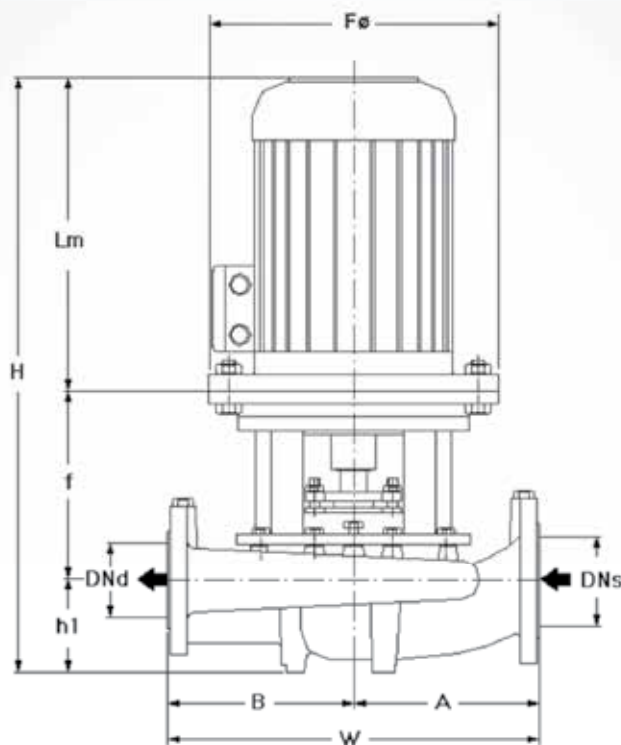

YPH Series Fire Pumps Dimension Table

	Engine	FLANGES		GENERAL			PUMP				
		KW	IEC	Lm	DNs-DNd	H	hl	f	W	A	B
				mm	mm	mm	mm	mm	mm	mm	mm
40-200	2 Poles	3	100L	315	40	590	95	180	380	190	190
		4	112M	332		607	95	180	380	190	190
		5,5	132S	375		675	95	205	380	190	190
		7,5	132S	375		675	95	205	380	190	190
		77	160M	497		816	95	230	380	190	190

	Engine	FLANGES		GENERAL			PUMP				
		KW	IEC	Lm	DNs-DNd	H	hl	f	W	A	B
				mm	mm	mm	mm	mm	mm	mm	mm
40-250	2 Poles	5,5	132S	375	40	688	100	213	440	215	225
		7,5	132S	375		688	100	213	440	215	225
		11	160M	491		829	100	238	440	215	225
		15	160M	491		829	100	238	440	215	225

In-line Type Fire Pumps

		Engine		FLANGES	GENERAL	PUMP					
		KW	IEC	Lm	DNs-DNd	H	hl	f	W	A	B
				mm	mm	mm	mm	mm	mm	mm	mm
65-280	2 Poles	22	180M	549	100/65	989	110	330	475	225	250
		30	200L	637		1077	110	330	475	225	250
		37	200L	637		1077	110	330	475	225	250
		45	225M	680		1120	110	330	475	225	250
		55	250M	755		1195	110	330	475	225	250

		Engine		FLANGES	GENERAL	PUMP					
		KW	IEC	Lm	DNs-DNd	H	hl	f	W	A	B
				mm	mm	mm	mm	mm	mm	mm	mm
80-280	2 Poles	37	2255	637	125/80	1102	125	340	525	250	275
		45	225M	680		1145	125	340	525	250	275
		55	250M	755		1220	125	340	525	250	275
		75	2805	767		1232	125	340	525	250	275

		Engine		FLANGES	GENERAL	PUMP					
		KW	IEC	Lm	DNs-DNd	H	hl	f	W	A	B
				mm	mm	mm	mm	mm	mm	mm	mm
80-280	2 Poles	45	225M	680	150/100	1200	150	370	580	280	300
		55	250M	755		1305	150	400	580	280	300
		75	2805	767		1317	150	400	580	280	300
		90	280M	818		1368	150	400	580	280	300

Hydraulic Range

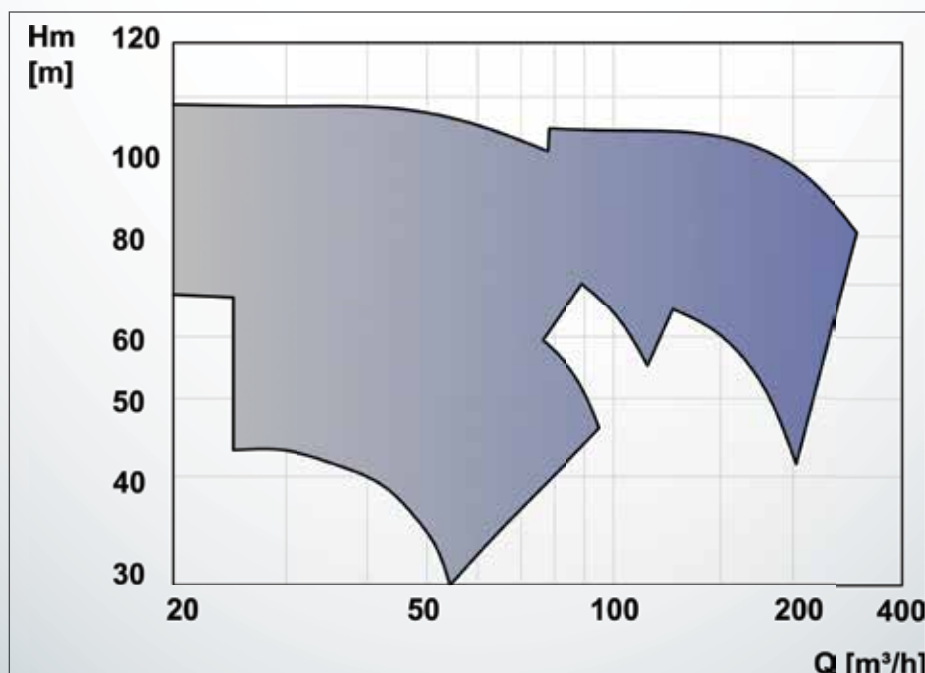

Split Casing Double Suction Centrifugal Fire Pumps

Areas of Use

In fire extinguishing systems;

- Hospitals
- Offices
- Airports
- Factories
- Schools
- Pharmaceutical Plants
- Warehouses
- Industrial Plants



Pumped Liquids

It is used in pumping clean and sea water that do not contain solid particles and fibre.

Design

- They are single-staged horizontally separable casing radial impeller double-suction pumps.
- Pump performances comply with NFPA standards.
- Due to the back-to-back design of the double-suction radial impeller, the axial load is reset.
- The inlet-outlet flanges are located on the same axis.
- It is easy to install.
- Double-suction pumps have the advantage of low NP5H character.
- Pump and electric engines are connected with flexible couplings on standard chassis. It is also possible to drive with a diesel engine.
- In standard material, the impeller, casing wear ring and gland are made of bronze, and the shaft is made of stainless steel.

Sealing

Gland packing is preferred in fire groups with shaft sealing certificate.

Bearing housing

Maintenance-free self-lubricating bearings have been used as pump bearing elements.

Split Casing Double Suction Centrifugal Fire Pumps

Pump Naming

YSPS 100-250

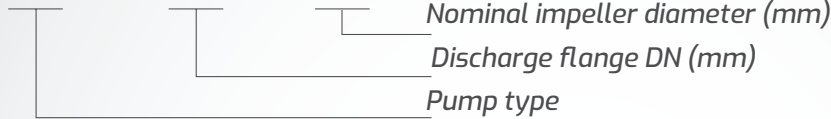

Technical Specifications	
Suction flange	DN80/DN400
Discharge flange	DN65/DN350
Flow	50-1800m ³ /h
Discharge pressure	20-185 m
Operating pressure	16-20 bar
Speed range	1450 -3600 rpm

Material Specifications	
Casing	GG25 (PN16) / GGG40 (PN 25)
Impeller	Bronze or stainless steel cast
Shaft	MSI 316
Sealing	Gland packing
Bearing housing	Rolling bearing
Suction/ Discharge flanges	PN 16 (DIN 2533)



Capacity



Flow

220-8000 gpm
50-1800 m³/h



Pressure

30-262 psi
20-185 mSS

Driver Options



Electrical



Diesel

Hazard Class



Mild



Ordinary



High



Special Risk

Application Areas



Fire Cabinet



Hydrant



Sprinkler



Overflow



Foam

Split Casing Double Suction Centrifugal Fire Pumps

Pump Sizes

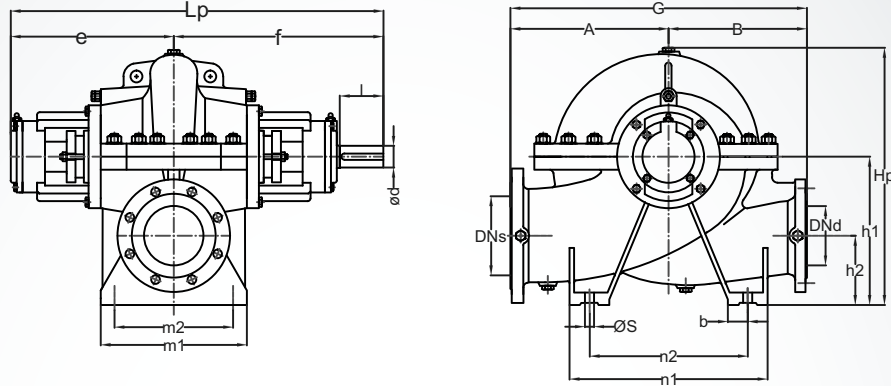

General Pump Sizes

Pump Type	Flanges		Lp	e	f	h1	h2	b	m1	m2	n1	n2	50	A	B	l	dØ	Hp	G
	DNs	DNd																	
65-250	700	65	585	260	325	250	115	90	240	200	350	275	18	275	225	60	28	432	500
80-250	725	80	674	294	380	280	140	80	234	190	400	340	19	300	275	80	35	482	575
80-360	725	80	674	294	380	315	135	80	234	190	400	340	19	325	275	80	35	555	600
100-250	750	100	772	372	400	315	155	80	270	225	400	340	19	325	275	80	35	525	600
700-375	750	100	820	350	470	355	145	110	290	230	435	350	22	365	325	110	45	587	690
725-375	200	125	874	377	497	400	200	75	250	200	470	400	20	400	350	110	45	665	750
750-250	200	150	870	375	495	375	175	100	340	270	500	400	23	400	325	110	45	640	725
725-400	150	125	942	412	530	375	175	100	370	300	600	500	23	450	400	110	55	695	850
750-375	200	750	942	472	530	375	175	100	370	300	500	400	23	400	350	110	55	645	750
750-400	200	750	942	472	530	400	200	100	370	300	600	500	23	475	400	110	55	730	875
750-500	200	750	942	472	530	450	250	100	370	300	650	550	23	550	500	110	55	870	1050
200-375	250	200	972	427	545	430	205	100	430	360	500	400	23	450	375	110	55	735	825
200-400	250	200	972	427	545	430	205	100	430	360	600	500	23	525	425	110	55	788	950
200-500	1250	200	7042	447	595	475	220	100	460	390	650	550	23	550	500	740	65	876	1050
250-375	300	250	7062	457	605	500	225	100	480	410	650	550	23	525	425	740	65	841	950
250-400	300	250	7042	447	595	500	225	100	460	390	650	550	23	550	450	740	65	873	1000
250-500	300	250	7062	457	605	525	240	100	480	470	650	550	23	600	500	740	65	952	1100
350-400	400	350	7290	570	720	610	295	150	600	500	750	600	28	600	500	740	75	1010	1100
350-500	400	350	7290	570	720	630	375	150	600	500	800	650	28	650	550	740	75	1055	1200

Hydraulic Range

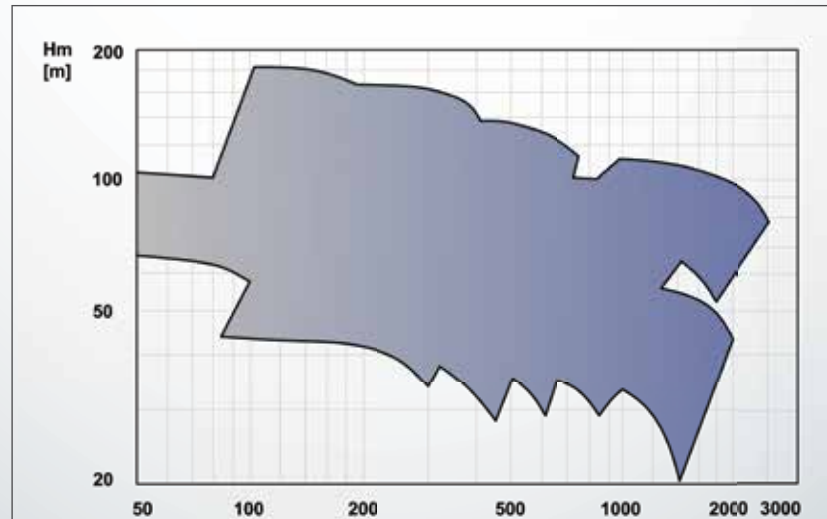

Split Casing Double Suction Centrifugal Fire Pumps

Areas of Use

In fire extinguishing systems;

- Hospitals
- Offices
- Airports
- Factories
- Schools
- Pharmaceutical Plants
- Warehouses
- Industrial Plants

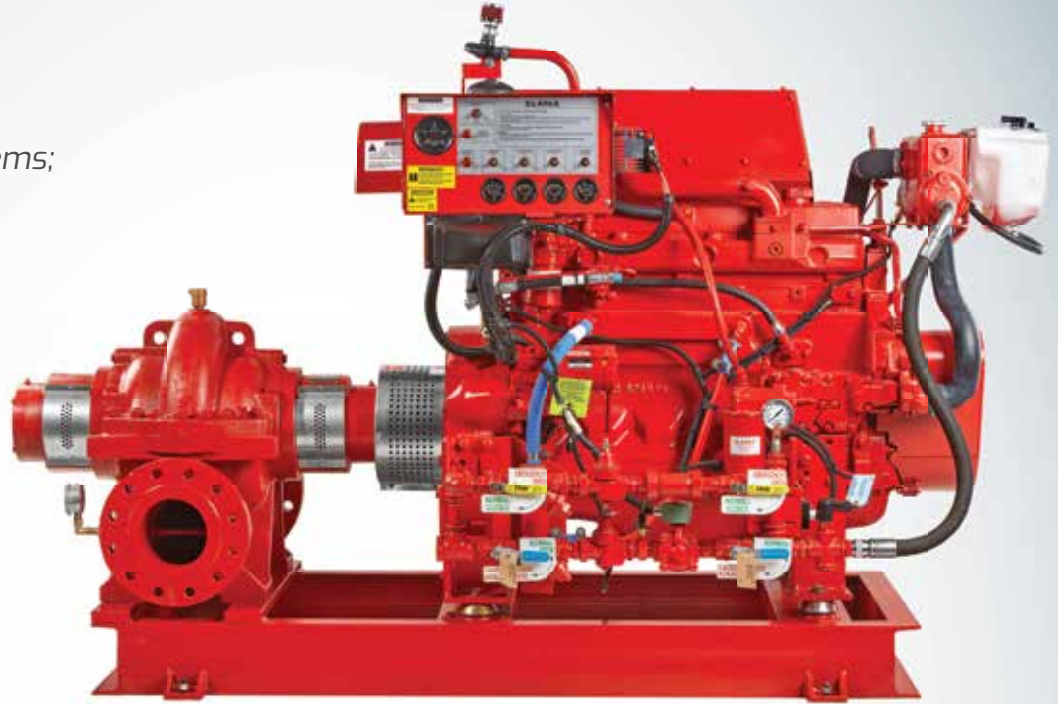

Design

- They are single-staged horizontally separable casing radial impeller double-suction pumps.
- With the double-suction radial impeller's back to back design and closed impeller structure, the axial load is reset.
- Pump flanges are designed according to ANSI/ASME 676.7 Class 250.
- The inlet-outlet flanges are located on the same axis.
- Shaft sealing is provided with gland gaskets.
- Double-suction pumps have the advantage of low NPSH character.
- Pump and electric engines are connected with flexible couplings on standard chassis. It is also possible to drive with a diesel engine.
- The impeller of the pump is made of bronze material, and the shaft is made of stainless steel.

Material Specifications

Casing	Cast iron
Impeller	Bronze
Shaft	A151316
Sealing	Gland packing
Bearing housing	Rolling bearing
Suction/discharge flanges	ANSI / A5ME 876.7 Class 250

Technical Specifications

Flow range	100 - 2000 GPM (23 - 454 m ³ /h)
Man. pressure range	60 - 274 psi (44 -188 m)
Operating pressure	16-24bar
Speed range	1800-2900 rpm
Suction flange	4"-10"
Discharge flange	2 1/2"-8"
Discharge flange	2"-6"

Technical Specifications (UL Listed/FM Approved)

Flow range	250-1000GP-M(56-227m ³ /h)
Man. pressure range	75-171 psi (52-120 m)
Operating pressure	16-24bar
Speed range	2900 rpm
Suction flange	4"-6"
Discharge flange	2 1/2"-4"

Split Casing Double Suction Centrifugal Fire Pumps

Driver Options



Electrical



Diesel



Listed Capacity



Flow

100-2000 gpm
23-454 m³/h



Pressure

60-274 psi
44-188 mSS

Hazard Class



Mild



Ordinary



High



Special Risk

Application Areas



Fire Cabinet



Hydrant



Sprinkler



Overflow



Foam

Pump Sizes

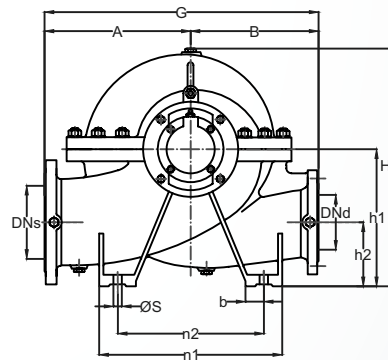
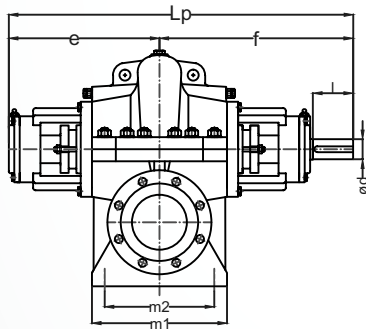

General Pump Sizes

Pump Type	Flanges		Lp	e	f	h1	h2	Hp	A	B	G	b	m1	m2	n1	n2	Ø5	l	Ød
	DNs	DNd																	
65-250	4"	2 1/2"	585	260	325	250	115	425	285	225	510	70	240	190	350	275	18	60	28
80-250	5"	3"	680	300	380	280	140	455	300	275	575	80	234	190	400	330	18	80	35
80-360	5"	3"	680	300	380	315	135	550	325	275	600	80	734	190	400	330	18	80	35
100-250	6"	4"	715	315	400	315	155	550	325	275	600	80	270	220	400	330	18	80	35
100-315	6"	4"	820	350	470	355	745	585	360	320	680	90	290	230	435	350	23	110	45
150-250	8"	6"	870	375	495	375	775	635	400	325	725	100	340	270	500	400	23	110	45
125-400	6"	5"	945	415	530	375	775	700	450	400	850	100	370	300	500	400	23	110	55
150-315	8"	6"	945	415	530	375	775	645	400	350	750	100	370	300	500	400	23	110	55
150-400	8"	6"	945	415	530	400	200	730	475	400	875	100	370	300	500	400	23	110	55
200-400	10"	8"	975	430	545	430	205	790	525	425	950	100	430	360	600	500	23	110	55

Split Casing Double Suction Centrifugal Fire Pumps

YPSP UL Listed Fire Pumps Selection Table

Flow		Dimension	Model Type	Net Pressure Range		Speed	Max. Operating Pressure
GPM	m ³ /h	ine		psi	m	rpm	psi
100	23	4"-2 1/2"	YPSP 65-250	84-132	59-93	2950	210
100	23	4"-2 1/2"	YPSP 65-250	75-119	53-84	2800	210
150	34	4"-2 1/2"	YPSP 65-250	83-132	58-93	2950	210
150	34	4"-2 1/2"	YPSP 65-250	75-119	53-84	2800	210
200	45	4"-2 1/2"	YPSP 65-250	82-132	58-93	2950	210
200	45	5"-3"	YPSP 80-250	102-165	72-116	2950	245
200	45	5"-3"	YPSP 80-360	140-274	98-193	2950	345
200	45	4"-2 7/2"	YPSP 65-250	74-119	52-84	2800	270
200	45	5"-3"	YPSP 80-250	92-148	65-104	2800	245
200	45	5"-3"	YPSP 80-360	126-246	89-173	2800	345
200	45	5"-3"	YPSP 80-360	108-212	76-749	2600	345
200	45	5"-3"	YPSP 80-360	89-174	63-722	2350	345
200	45	5"-3"	YPSP 80-360	71-138	50-97	2100	345
250	57	4"-2 7/2"	YPSP 65-250	80-132	56-93	2950	270
250	57	5"-3"	YPSP 80-250	102-165	72-776	2950	245
250	57	5"-3"	YPSP 80-360	140-273	98-792	2950	345
250	57	4"-2 1/2"	YPSP 65-250	72-119	57-84	2800	270
250	57	5"-3"	YPSP 80-250	92-149	65-705	2800	245
250	57	5"-3"	YPSP 80-360	726-246	89-173	2800	345
250	57	5"-3"	YPSP 80-360	709-272	77-749	2600	345
250	57	5"-3"	YPSP 80-360	89-774	63-122	2350	345
250	57	5"-3"	YPSP 80-360	71-138	50-97	2100	345
300	68	4"-2 1/2"	YPSP 65-250	78-132	55-93	2950	270
300	68	5"-3"	YPSP 80-250	102-165	72-116	2950	245
300	68	5"-3"	YPSP 80-360	141-273	99-192	2950	345
300	68	4"-2 7/2"	YPSP 65-250	69-119	49-84	2800	270
300	68	5"-3"	YPSP 80-250	92-149	65-705	2800	245
300	68	5"-3"	YPSP 80-360	127-246	89-173	2800	345
300	68	5"-3"	YPSP 80-360	109-212	77-149	2600	345
300	68	5"-3"	YPSP 80-360	89-173	63-122	2350	345
300	68	5"-3"	YPSP 80-360	70-137	49-96	2100	345
400	97	5"-3"	YPSP 80-250	101-166	71-117	2950	245
400	91	5"-3"	YPSP 80-360	139-270	98-190	2950	345
400	91	5"-3"	YPSP 80-250	91-149	64-105	2800	245
400	91	5"-3"	YPSP 80-360	125-242	88-170	2800	345
400	91	5"-3"	YPSP 80-360	106-209	75-147	2600	345
400	91	5"-3"	YPSP 80-360	86-170	60-120	2350	345
400	97	5"-3"	YPSP 80-360	67-135	47-95	2100	345
450	702	5"-3"	YPSP 80-250	700-766	70-117	2950	245
450	102	5"-3"	YPSP 80-360	737-269	96-789	2950	345
450	102	5"-3"	YPSP 80-250	90-749	63-105	2800	245
450	102	5"-3"	YPSP 80-360	723-242	87-170	2800	345
450	102	5"-3"	YPSP 80-360	105-209	74-147	2600	345
450	102	5"-3"	YPSP 80-360	84-170	59-120	2350	345
450	102	5"-3"	YPSP 80-360	65-135	46-95	2100	345
500	774	5"-3"	YPSP 80-250	99-765	70-116	2950	245
500	774	5"-3"	YPSP 80-360	735-269	95-189	2950	345
500	774	6"-4"	YPSP 100-250	92-180	65-127	2950	265
500	774	6"-4"	YPSP 100-315	154-212	108-149	2950	320
500	774	5"-3"	YPSP 80-250	88-149	62-105	2800	245
500	774	5"-3"	YPSP 80-360	121-242	85-170	2800	345
500	774	6"-4"	YPSP 100-250	84-762	59-114	2800	265
500	774	6"-4"	YPSP 100-315	738-797	97-134	2800	375
500	774	5"-3"	YPSP 80-360	103-207	72-146	2600	345
500	774	6"-4"	YPSP 100-315	119-216	84-152	2600	375

Split Casing Double Suction Centrifugal Fire Pumps

YPSP UL Listed Fire Pumps Selection Table

Flow		Dimension	Model Type	Net Pressure Range		Speed	Max. Operating Pressure
GPM	m3/h	ine		psi	m	rpm	psi
500	774	5"-3"	YPSP 80-360	82-169	58-119	2350	345
500	774	6"-4"	YPSP 100-315	94-777	66-724	2350	315
500	774	5"-3"	YPSP 80-360	64-734	45-94	2100	345
500	774	6"-4"	YPSP 100-315	75-742	53-100	2100	315
750	170	6"-4"	YPSP 100-250	89-778	63-125	2950	265
750	170	6"-4"	YPSP 100-315	750-273	105-150	2950	320
750	170	6"-4"	YPSP 100-250	79-160	56-113	2800	265
750	170	6"-4"	YPSP 100-315	134-192	94-135	2800	315
750	170	6"-4"	YPSP 100-315	114-216	80-152	2600	315
750	170	6"-4"	YPSP 100-315	92-175	65-723	2350	315
750	170	6"-4"	YPSP 100-315	71-141	50-99	2100	315
750	170	6"-5"	YPSP 125-400	121-187	85-132	2100	290
750	170	6"-5"	YPSP 125-400	88-155	62-109	1800	290
1000	227	6"-4"	YPSP 100-250	81-175	57-123	2950	265
1000	227	8"-6"	YPSP 150-250	81-139	57-98	2950	245
1000	227	8"-6"	YPSP 150-315	135-189	95-733	2950	265
1000	227	6"-4"	YPSP 100-250	72-157	57-770	2800	265
1000	227	8"-6"	YPSP 150-250	72-125	57-88	2800	245
1000	227	8"-6"	YPSP 150-315	121-170	85-720	2800	265
1000	227	8"-6"	YPSP 150-315	104-180	73-127	2600	265
1000	227	8"-6"	YPSP 150-315	83-147	58-103	2350	265
1000	227	8"-6"	YPSP 150-400	161-180	113-127	2350	290
1000	227	8"-6"	YPSP 150-315	65-117	46-82	2100	265
1000	227	6"-5"	YPSP 125-400	119-186	84-131	2100	290
1000	227	8"-6"	YPSP 150-400	728-779	90-126	2100	290
1000	227	6"-5"	YPSP 125-400	86-753	60-108	1800	290
1000	227	8"-6"	YPSP 150-400	93-743	65-101	1800	290
1250	284	8"-6"	YPSP 150-250	79-139	56-98	2950	245
1250	284	8"-6"	YPSP 150-315	132-187	93-132	2950	265
1250	284	8"-6"	YPSP 150-250	71-125	50-88	2800	245
1250	284	8"-6"	YPSP 150-315	117-168	82-118	2800	265
1250	284	8"-6"	YPSP 150-315	100-180	70-127	2600	265
1250	284	8"-6"	YPSP 150-315	80-147	56-703	2350	265
1250	284	8"-6"	YPSP 150-400	158-178	111-125	2350	290
1250	284	8"-6"	YPSP 150-315	63-776	44-82	2100	265
1250	284	6"-5"	YPSP 125-400	776-785	82-130	2100	290
1250	284	8"-6"	YPSP 150-400	725-776	88-124	2100	290
1250	284	10"-8"	YPSP 200-400	779-754	84-108	2100	290
1250	284	6"-5"	YPSP 125-400	82-152	58-107	1800	290
1250	284	8"-6"	YPSP 150-400	89-141	63-99	1800	290
1250	284	70"-8"	YPSP 200-400	87-139	61-98	1800	290
1500	341	8"-6"	YPSP 150-250	78-139	55-98	2950	245
1500	341	8"-6"	YPSP 150-315	128-185	90-730	2950	265
1500	341	8"-6"	YPSP 150-250	70-125	49-88	2800	245
1500	341	8"-6"	YPSP 150-315	114-166	80-117	2800	265
1500	341	8"-6"	YPSP 150-315	97-180	68-127	2600	265
1500	341	8"-6"	YPSP 150-315	77-745	54-702	2350	265
1500	341	8"-6"	YPSP 150-400	755-775	709-723	2350	290
1500	341	8"-6"	YPSP 150-315	60-776	42-82	2100	265
1500	341	8"-6"	YPSP 150-400	727-775	85-123	2100	290
1500	341	70"-8"	YPSP 200-400	779-754	84-108	2100	290
1500	341	8"-6"	YPSP 150-400	86-138	60-97	1800	290
1500	341	10"-8"	YPSP 200-400	87-137	67-96	1800	290
2000	454	10"-8"	YPSP 200-400	117-152	82-107	2100	290
2000	454	10"-8"	YPSP 200-400	84-137	59-96	1800	290

Split Casing Double Suction Centrifugal Fire Pumps

YPSP UL Listed Fire Pumps Selection Table

Product	Place of Production	Capacity (gal/min)	Pressure Range (psi)	Speed (rpm)	Suction Flange	Dis-charge Flange	Stage Number	Certificate Type	Certificate Class
YPSP 65-250	Turkey	250	78-131	2950	4	21/2	1	FM Approved	1311
YPSP 65-250	Turkey	300	75-130	2950	4	21/2	1	FM Approved	1311
YPSP 80-250	Turkey	300	102-165	2950	5	3	1	FM Approved	1311
YPSP 80-250	Turkey	400	101-163	2950	5	3	1	FM Approved	1311
YPSP 80-250	Turkey	450	99-163	2950	5	3	1	FM Approved	1311
YPSP 80-250	Turkey	500	98-162	2950	5	3	1	FM Approved	1311
YPSP 100-250	Turkey	500	92-171	2950	6	4	1	FM Approved	1311
YPSP 100-250	Turkey	750	86-169	2950	6	4	1	FM Approved	1311
YPSP 100-250	Turkey	1000	80-168	2950	6	4	1	FM Approved	1311

Hydraulic Range

UL YPSP

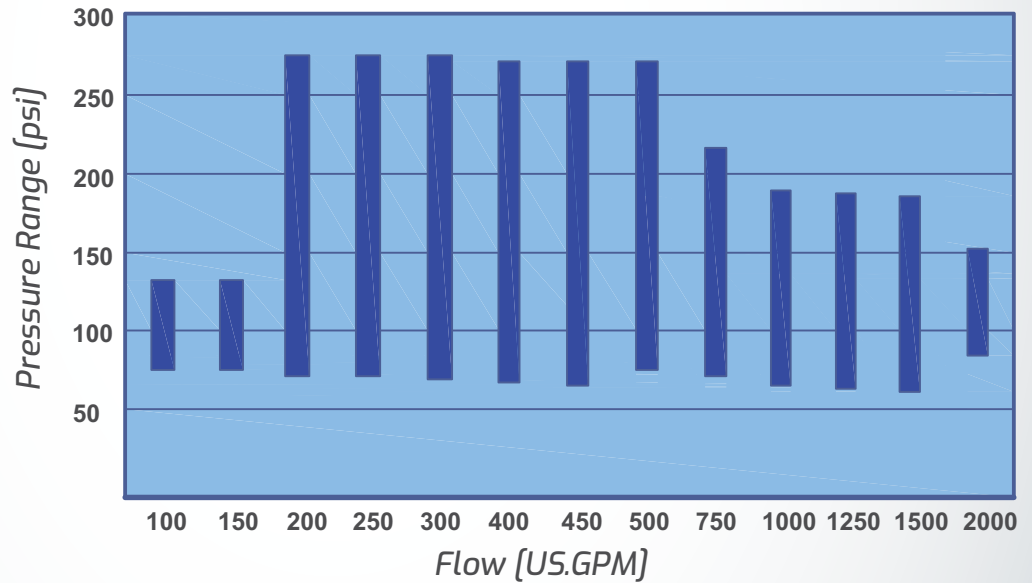

UL FM YPSP

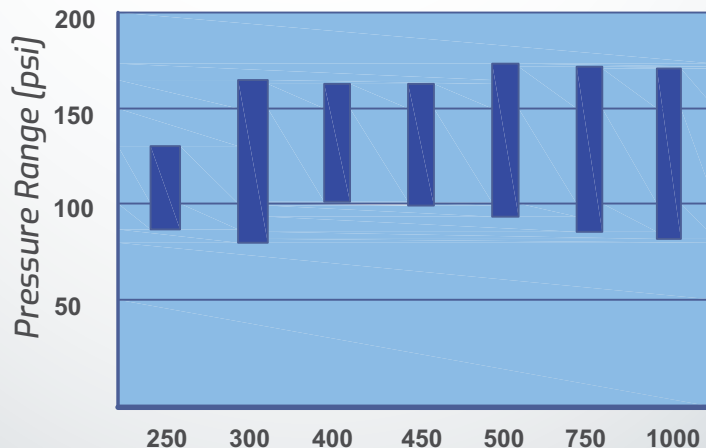

End-Suction Volute Casing Fi-Fi System Pumps

Areas of Use

- In Fi-Fi (Fire Fighter) system trailers
- In vessels, gland water and sea water pumping
- In big fire extinguishing systems
- In industrial and social plants

Pumped Liquids

It is used in pumping clean and sea water that do not contain solid particles and fibre.

Design

- They are horizontal type, single-stage, single-inlet, suction nozzle on the horizontal axis, discharge nozzle on top, shut-off impeller, volute casing centrifugal pumps.
- Since its volute is symmetrical, it can be installed as to operate in both directions. Due to this specification, it can also be connected to left-turn engines.
- ENM pump impellers are of double slope type. The impellers are dynamically balanced on the electronic balancing machine. Axial thrust force is balanced with back wear ring and balance holes.
- The pumps have a rigid shaft that can operate at different loads.
- Inside the suction casing, there is a plain bearing lubricated with water.
- It has a compact structure due to the short distance between the flexure resistant shaft and the bearing and the volute. Due to this specification, it is available for the applications with limited volumes (such as Marine fire brigade).
- In normal applications, two roller bearings are used. The cantilever bearing used is optional.

Bearing housing

In ENM series pumps, two types of bearings, as sliding and ball bearings, are used. When the roller bearing is installed on the engine side, the sliding bearing stays on one side and the pump on the other side.

Sealing

As a standard, shaft sealing is ensured by a gland gasket that is cooled and lubricated with pumped water. There is also a mechanical seal option according to the requirements of our customers.

Pump Naming

ENM 300-500



Nominal impeller diameter (mm)
Discharge flange DN (mm)
Pump type



End-Suction Volute Casing Fi-Fi System Pumps

Material Options						
Part	material					
	Nodular cast iron (GGG40)	Bronze cast (G-CuSn10)	Stainless steel (AISI329)	Stainless steel (AISI420)	Stainless steel (AISI304)	Stainless steel (AISI316)
Casing	●	●			●	●
Impeller	●	●			●	●
Wear ring		●			●	●
Shaft			●	●	●	●

Technical Specifications	
Flow range	400- 4000 m3/h
Discharge pressure	60-150 m
Operating pressure	16 bar
Operating temperature	-20-110 X
Speed range	1000-1800 rpm
Suction flange	DN300-DN500
Discharge flange	DN250-DN400

Please consult to our company for different material options.

Pump Sizes

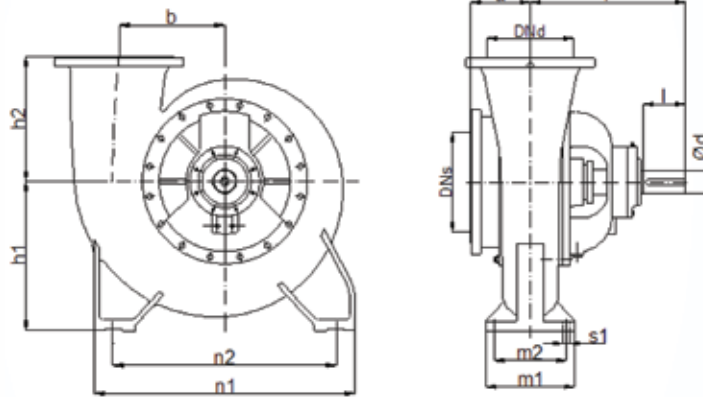

General Pump Sizes														
Pump Type	Ranges(PN16)		a	f	h1	h2	b	m1	m2	n1	n2	s1	d	l
	DN _s	DN _d												
ENM 250-550	300	250	230	544	500	425	400	300	240	800	650	30	75	140
ENM 300-550	350	300	230	544	550	500	400	300	240	800	650	30	75	140
ENM 350-550	400	350	240	625	600	500	425	360	290	1050	900	30	90	170
ENM 400-550	500	400	280	640	600	550	400	360	290	1050	900	30	90	170

Hydraulic Range

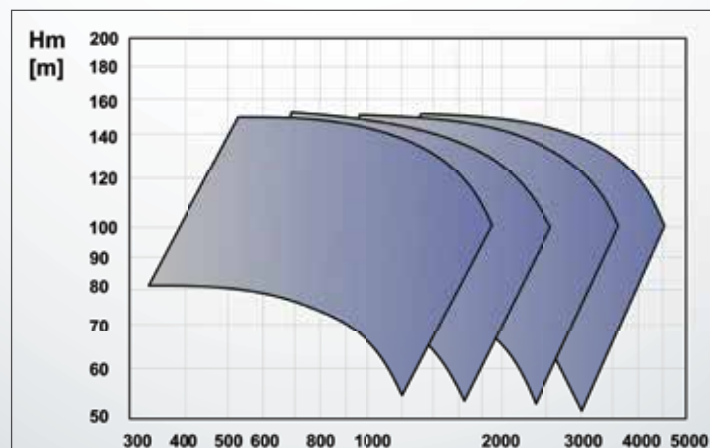



Cabin Applications

Cabin fire extinguishing systems are applied to all fire group pumps (such as YNM, YP5P and YPH series).

Advantages of Cabin Applications

- It provides great advantages in cases where the pumps are required to be used, but cannot be located inside a building, particularly in places such as a protected area.
- The cabin system ensures that the pump inside is protected from the adverse effects of the external environment, and it also isolates the transition of the pump-borne noise to the external environment.
- The cabin can be made from containers at international standards, as well as in desired dimensions with special noise insulation.
- Particularly the container cabin system pumps have equipment that can be easily transported by lorries, trucks, trains, vessels, aircraft and can be lifted by crane.
- It provides effective solutions for fire fighting applications with easy installation and maintenance operations in industrial plants, mining, agriculture, energy and building systems.

Container Applications

You can locate your pump groups anywhere in the building or plant. It provides very clean operation. The valves and equipment within the system are easy to be located.



Advantages of Container Applications

- Easy access to equipment in emergency repair situations with easy and safe maintenance specification.
- Efficient system operation with high performance electric engines.
- Easy monitoring of system performance values.
- Engine protections that make the engine run dry and safe.
- The electric and diesel engines and control panels are tested in factories where the production is performed.
- The performance and pressure tests of the fire pumps are carried out in our company and their compliance with the standards is controlled.
- In package fire systems, it is tested hydrostatically and controlled whether there is any water leak in pipes and system or not.
- Safe and easy working environment for the people who will carry out the maintenance and operation.
- Dry, comfortable and easy system operation that will not disturb the environment.
- All container fire set systems have flow meters that can continuously measure the system performance. Provides weekly testing individually for each pump.
- On the discharge side of each pump, check valves of good quality, complying with standards and easy to maintain are used.
- The spacer coupling is used in the engine connection of each pump. Allows the engine part to be easily separated from the pump.
- Against any adverse conditions in the suction line; the feeding is performed in the line and ensured that the suction pipe and the pump are constantly filled with water.
- Horizontal, separable casing pumps are used in fire container groups.
- Eccentric reduction is used to prevent air pockets on the suction side of the pumps.



Fire Groups Engine Specifications**Electric Engines**

- Electric engines must be in compliance with the standards.
- The engines must be designed per continuous operating conditions.
- Where water splash is possible, the engines must be designed in totally enclosed type.
- There must be an energy line to feed the engines even if the electricity of the building where fire safety is provided is cut off.
- If the electricity supply is unreliable, a backup source must be provided.
- In case of feeding with generator; the generator must be designed according to NFPA 37 and NFPA 770 Type 10 standards.

Diesel Engines

- Diesel engines to be used in fire pumps must be reliable, first class and designed for fire extinguishing systems.
- They must be equipped with the necessary mechanism as to operate for at least 30 minutes a week.
- The engine power must have at least 10% more power than the required maximum shaft power.
- In engine power selections, the ambient temperature and sea altitude etc., conditions must be taken into consideration and then the necessary corrections must be made.
- Pump-engine connection must be made with flexible coupling.
- There must be an automatic gas mechanism that will keep the engine speed constant in 9670 range even under shut-off discharge pressure and maximum load conditions.
- In case there are more circuits than the rated speed, there must be an "overspeed shutdown device" to stop the engine.
- There must be a tachometer indicating the engine speed.
- There must be an oil pressure gauge indicating the engine oil pressure.
- There must be a temperature indicator indicating the engine coolant temperature.
- All engine equipment must be fixed to the properly secured equipment panel.

Fire Groups Engine Specifications

- All cables that must be connected to the control unit must be carried to a terminal group by being connected at the factory.
- Starting must be performed by means of the battery group.
- There must be two battery groups as main and spare.
- The battery groups must be selected at twice the power required to press the starter 6 times for 3 minutes.
- A manually operated contactor must be provided as to allow the voltage of both battery groups to be supplied manually.
- Depending on the engine power used, the fuel tank must be used in accordance with the capacity calculation specified in NFPA 20.
- Diesel Engine Types;
 - Water/Air cooled (w/radiator)
 - Water Cooled (w/exchanger)
- Conventional Diesel Engine Types;
 - Air Cooled
 - Water Cooled

Engine Options per Pump Type

Pump Type	W/Electric Engine	W/Diesel Engine	
		Approved	Conventional
In-line type	✓	—	—
End-suction	✓	✓	✓
Horizontally split casing	✓	✓	✓

Fire Group Accessory Specifications

Accessories (Optional)

- The valve can be selected from the table below depending on the pump's rated flow.
- The connection to control units must be ensured through suction line rising shaft, discharge line rising shaft or butterfly valve and valve monitoring switch (optional).
- If the diameters of the pump suction flange and the suction pipe are different, then eccentric reduction must be used. (Pump suction diameter must not be reduced.)
- If the diameters of the pump discharge flange and the discharge pipe are different, then eccentric reduction must be used.
- The fire pump must be equipped with casing relief valve, automatic air discharge valve (in pumps with horizontally separable casing) and pressure gauges.

Rated Flow (GPM)	Suction Pipe Diameter"	Discharge Pipe Diameter**	Safety Valve Diameter	Safety Valve Drain Pipe Diameter	Flow Meter Diameter	Testing Valve Number-Diameter	Testing Valve Collector Diameter
25	1"-DN 25	1"-DN 25	3/4"-DN 15	1"-DN 25	1 1/4"-DN 32	1 x 1 1/2	1"-DN 25
50	1 1/2"-DN 40	1 1/4"-DN 32	1 1/4"-DN 32	1 1/2"-DN 40	2"-DN 50	1 x 1 1/2	1 1/2"-DN 40
100	2"-DN 50	2"-DN 50	1 1/2"-DN 40	2"-DN 50	2 1/2"-DN 65	1 x 2 1/2	2 1/2"-DN 65
150	2 1/2"-DN 65	2 1/2"-DN 65	2"-DN 50	2 1/2"-DN 65	3"-DN 80	1 x 2 1/2	2 1/2"-DN 65
200	3"-DN 80	3"-DN 80	2"-DN 50	2 1/2"-DN 65	3"-DN 80	1 x 2 1/2	2 1/2"-DN 65
250	4"-DN 100	3"-DN 80	2"-DN 50	2 1/2"-DN 65	4"-DN 100	1 x 2 1/2	3"-DN 80
300	4"-DN 100	4"-DN 100	2 1/2"-DN 65	4"-DN 100	4"-DN 100	1 x 2 1/2	3"-DN 80
400	4"-DN 100	4"-DN 100	3"-DN 80	5"-DN 125	4"-DN 100	2 x 2 1/2	4"-DN 100
450	5"-DN 125	5"-DN 125	3"-DN 80	5"-DN 125	4"-DN 100	2 x 2 1/2	4"-DN 100
500	5"-DN 125	5"-DN 125	3"-DN 80	5"-DN 125	5"-DN 125	2 x 2 1/2	4"-DN 100
750	6"-DN 150	6"-DN 150	4"-DN 100	6"-DN 150	5"-DN 125	3 x 2 1/2	6"-DN 150
1000	8"-DN 200	6"-DN 150	4"-DN 100	8"-DN 200	6"-DN 150	4 x 2 1/2	6"-DN 150
1250	8"-DN 200	8"-DN 200	6"-DN 150	8"-DN 200	6"-DN 150	6 x 2 1/2	8"-DN 200
1500	8"-DN 200	8"-DN 200	6"-DN 150	8"-DN 200	8"-DN 200	6 x 2 1/2	8"-DN 200
2000	10"-DN 250	10"-DN 250	6"-DN 150	10"-DN 250	8"-DN 200	6 x 2 1/2	8"-DN 200
2500	10"-DN 250	10"-DN 250	6"-DN 150	10"-DN 250	8"-DN 200	6 x 2 1/2	10"-DN 250
3000	12"-DN 300	12"-DN 300	8"-DN 200	12"-DN 200	8"-DN 200	6 x 2 1/2	10"-DN 250

NFPA20 Table-4.27(a)

* Prepared per NFPA 20 by using 4" instead of 3 1/2."

** Valid for the section at a pre-suction length of 10 diameter.

*** Pump flanges may differ from pipe diameter.

Jockey Pump

- It must have a capacity of at least 1 gpm or the capacity to bring the pressure to the required level by meeting an allowable leak within 10 minutes.
- It must not have a pressure lower than the minimum pressure required for the aqueous fire extinguishing system.

Electric Engine Fire Pump Controller

General Specifications

- The production of the panel must be performed with first class labour and materials, and must be at the level of international industrial product quality.
- The panel must be inspected and tested at the factory before its delivery.
- Terminal connection information must be available within the panel, the circuit diagram, spare lamps and telephone and fax numbers that must be consulted when necessary must be available.
- The entire control system design must be extremely reliable; it must be free from any elements that may prevent it from functioning in terms of design and material used.
- The meaning of all kinds of lights, buttons, etc. elements on the panel must be permanently labelled in a way that cannot be damaged and can be easily read.

Panel Case

- The panel must be made of red electrostatic powder painted (RAL 3000 or RAL 3020), phosphated 7.5 mm DKP sheet metal.
- The panel must have a protection (IP 55) that does not allow "splashing and spraying water" against liquid entry and "dust accumulation" against dust entry.
- The panel must be grounded as continuity at every point is ensured.
- The panel must be surface mounted (or footed) type, and the parts required for the installation must be provided together with the panel.
- The panel cover must be equipped with a quality lock and as lockable so that it cannot be opened by those who do not have a key.
- Non-standard elements must not be available on the panel cover, the indicators and control elements that must be monitored from outside the panel must be installed on the fixed wing.
- When the cabin cover is locked, no settings or elements must be accessible.
- The cable connection terminals must be located under the panel.

Electric Engine Fire Pump Controller

Controller Mechanism

- The pressure switches that enable pumps to start and stop must be installed to the system, and the system pressure measurement line must be appropriate for being connected to the pressure switch with a pipe.
- The pressure switch must be of a type that is not affected by vibration, the upper and lower set value can be adjusted independently, and displays the set value on it.
- The pump can operate automatically depending on the pressure switch or it must be operated manually by the push button on the panel or the site button connected to the panel terminals.
- This operation button must not be connected to the AUTOMATIC-MANUAL (will have no off position) selective switch.
- If the pump is operated by pressing the START button, the system must continue operating until the STOP button is pressed.
- Whether it is automatically or manually operated, the pump will stop if the STOP button is pressed, if the system pressure is not sufficient, the STOP button must not be of locked type in order to reoperate it when the STOP button is released.
- In case the pump runs automatically; if there is an Automatic Shut-off Mechanism, the stop operation must be realized after all conditions return to normal and the operation is realized for at least 10 minutes. The Minimum Run Timer to provide this operation must be located inside the unit.
- Optional; there may be a totally automatic test mechanism connected to the weekly time clock to enable the fire pump starts working on a certain day and time of the week and stops after operating for at least 10 minutes; in order to do this, the weekly time clock; discharges the water by keeping an electrically controlled solenoid valve open on the line to which the pressure switch is connected at the set day, hour and minute, and enables the pump to start by simulating the pressure drop in the system.

Signalization

- There must be information lights on the panel that provide easy understanding of the system and error tracking,
- The information lights must consist of at least following:
 - System Activated
 - Automatic Operation Activated
 - Automatic Operation Disabled
 - Phase Line Failure
 - Insufficient Phase

Electric Engine Fire Pump Controller

- There must be mutable, audible and non-closable lighted light error alarms on the panel.
- For the information lights, the lights with long lamp life, are easily visible even in brightness, and easy to be replaced must be used.

Power Circuit

- The energy cut-off switch of the panel must be selected at a current value of 15% more than the total load at the moment of engine start-up.
- The fire pump starting contactor must have rated contact current of 50% more than the direct starting current of the pump engine.
- The fire pump must not have thermal protection.
- The fire pump engine must have direct (or Star-Triangle) take off.
- The jockey pump must be thermally protected.
- The jockey pump engine must have direct take off.

Performance Specifications

- In order to monitor that all three energy feeding phases of the panel are available and that their order is correct, there must be phase number and sequence relay.
- The pumps that will be used in humid environments must have thermostat controlled heater to prevent water condensation inside the control panels.

Cabling

- The cable inlets and outlets of the panel must be bushed.
- All cables must be numbered so that they cannot be disconnected and damaged.
- All cabling must be done by complying with the cable colour coding.
- The cut-off switch terminals must be entered directly without the power cables move inside the cabin.

Diesel Engine Fire Pump Controller

General Specifications

- The production of the panel must be performed with first class labour and materials, and must be at the level of international industrial product quality.
- The panel must be inspected and tested at the factory before its delivery.
- Terminal connection information must be available within the panel, the circuit diagram, spare lamps and telephone and fax numbers that must be consulted when necessary must be available.
- The entire control system design must be extremely reliable; it must be free from any elements that may prevent it from functioning in terms of design and material used.
- The meaning of all kinds of lights, buttons, etc. elements on the panel must be permanently labelled in a way that cannot be damaged and can be easily read.

Panel Case

- The panel must be made of red electrostatic powder painted (RAL 2000 or RAL 3020), phosphated 7.5 mm DKP sheet metal.
- The panel must have a protection (IP 55) that does not allow "splashing and spraying water" against liquid entry and "dust accumulation" against dust entry.
- The panel must be grounded as continuity at every point is ensured.
- The panel must be surface mounted (or footed) type, and the parts required for the installation must be provided together with the panel.
- The panel cover must be equipped with a quality lock and as lockable so that it cannot be opened by those who do not have a key.
- Non-standard elements must not be available on the panel cover, the indicators and control elements that must be monitored from outside the panel must be installed on the fixed wing.
- When the cabin cover is locked, no settings or elements must be accessible. The cable connection terminals must be located under the panel.

Diesel Engine Fire Pump Controller

Controller Mechanism

- The pressure switches that enable pumps to start and stop must be installed to the system, and the system pressure measurement line must be appropriate for being connected to the pressure switch with a pipe.
- The pump can operate automatically depending on the pressure switch or it must be operated manually by the push button on the panel or the site button connected to the panel terminals.
- This operation button must be connected to the AUTOMATIC-MANUAL (will have no off position) selective switch.
- If the pump is operated by pressing the START button, the system must continue operating until the STOP button is pressed.
- Whether it is automatically or manually operated, the pump will stop if the STOP button is pressed, if the system pressure is not sufficient, the STOP button must not be of locked type in order to reoperate it when the STOP button is released.
- In case the pump runs automatically; if there is an Automatic Shut-off Mechanism, the stop operation must be realized after all conditions return to normal and the operation is realized for at least 10 minutes. The Minimum Run Timer to provide this operation must be located inside the unit.
- There must be two independent operating buttons on the panel, and each of them must be controlled from another battery group, and pressing one of the two buttons must be sufficient to operate the pump.
- There may be a totally automatic test mechanism connected to the weekly time clock to enable the fire pump starts working on a certain day and time of the week and stops after operating for at least 30 minutes; in order to do this, the weekly time clock; discharges the water by keeping an electrically controlled solenoid valve open on the line to which the pressure switch is connected at the set day, hour and minute, and enables the pump to start by simulating the pressure drop in the system.
- If low oil pressure level and high temperature error information come from the pump when the pump is running during the weekly test, then the control system must be able to immediately stop the pump with "safety shut-down".
- If the pump has operated automatically via the pressure switch; then the control system must automatically stop the engine and alarm only if "extremely high speed error" occurs. Under other conditions, the control unit must alarm, but the engine must continue running.
- The control unit; must start the engine six times in sequence for 15 seconds, then wait for 15 seconds and then start the engine, and in case of failure, the starter must lock the starter and alarm.

Diesel Engine Fire Pump Controller

Signalization

- There must be information lights on the panel that provide easy understanding of the system and error tracking,
- The information lights must consist of at least following:
 - System Activated
 - Pump Start Error
 - 1.Battery Insufficient Error
 - 2.Battery Insufficient Error
 - 1.Battery Charge Error
 - 2.Battery Charge Error
 - Engine Overspeed Error
- There must be mutable, audible and non-closable lighted light error alarms on the panel.
- For the information lights, the lights with long lamp life, are easily visible even in brightness, and easy to be replaced must be used.
- On the panel, there must be a recorder that optionally records the system pressure along with the day and time information, and this recorder must be of a type that operates even if the power is cut.
- On the panel, there must be ammeter and voltmeters that separately display the charge current and voltage of both battery charge groups.

Performance Specifications

- There must be two independent Battery Charger Units in order to charge both battery groups.
- The battery charger units must have fast running automatic fuse protection.
- The battery charger units must be capable of charging in accordance with battery type and voltage.
- The battery charger units must be able to fully charge the empty battery within 24 hours.
- When the operating signal of the pump is received, if the battery group I cannot be operated, the second battery group must be activated and start the system after waiting for 30 seconds.
- There must be an operation time counter that counts the duration of the fire pump operation.
- The minus end of the batteries and panel must be at the minus (-) pole together with the engine chassis.
- The pumps that will be used in humid environments must have thermostat controlled heater to prevent water condensation inside the control panels.

Diesel Engine Fire Pump Controller

- The connections between the diesel engine and the control unit, which are necessary to enable the control panel perform the required functions, must be made as cabled.
- The diesel engine must be able to be operated by means of the control unit on the engine even if the control panel is disabled.
- Regardless from the operation way of the diesel engine, the casing cooling must be ensured by automatically turning on the diesel engine coolant line (if any) solenoid valve.

Cabling

- The cable inlets and outlets of the panel must be bushed.
- All cables must be numbered so that they cannot be disconnected and damaged.
- All cabling must be done by complying with the cable colour coding.
- The cut-off switch terminals must be entered directly without the power cables move inside the cabin.
- The ground inlet and terminal must be independent.
- The cables between the control panel and the diesel engine-control unit must be within a steel mesh conduit.



masdaf

Mas Daf Makina Sanayi A.Ş.

*Aydınlı Mah. Birlik OSB 1 No'lu Cadde
No: 17 34953 Tuzla-Istanbul/Turkey*

Phone: +90 216 456 47 00

masgrup.com