

Features:

- Direct actuated directional spool valve with hand lever
- With spring return or detent, optional
- For subplate mounting
- Porting pattern to Din 24 340 form A, ISO 4401 and CETOP-RP 121H



FAMCO
هایپرمنت

Function, section

The type WMM valves are hand lever actuated directional spool valves. They control the start, stop and direction of a flow.

The directional valves basically comprise of a housing (1), hand lever (2), control spool (3), as well as one or two return springs (4). In the unoperated condition the control spool (3) is held in the neutral or its initial position by the return springs (4). The control spool (3) is actuated via the hand lever (2), this acts via a joint and the pin (5) directly onto the control spool (3). The spool is thereby moved out of its rest position into its required switched position. After the hand lever (2) has been returned to the switched position zero, the spool (3) is returned to the neutral position via the return springs (4).

Type H-4WMM../F.. (with detent)

These valves are either 2 or 3 position directional control valves which are fitted with a detent (6), which operates in all of the switched positions.

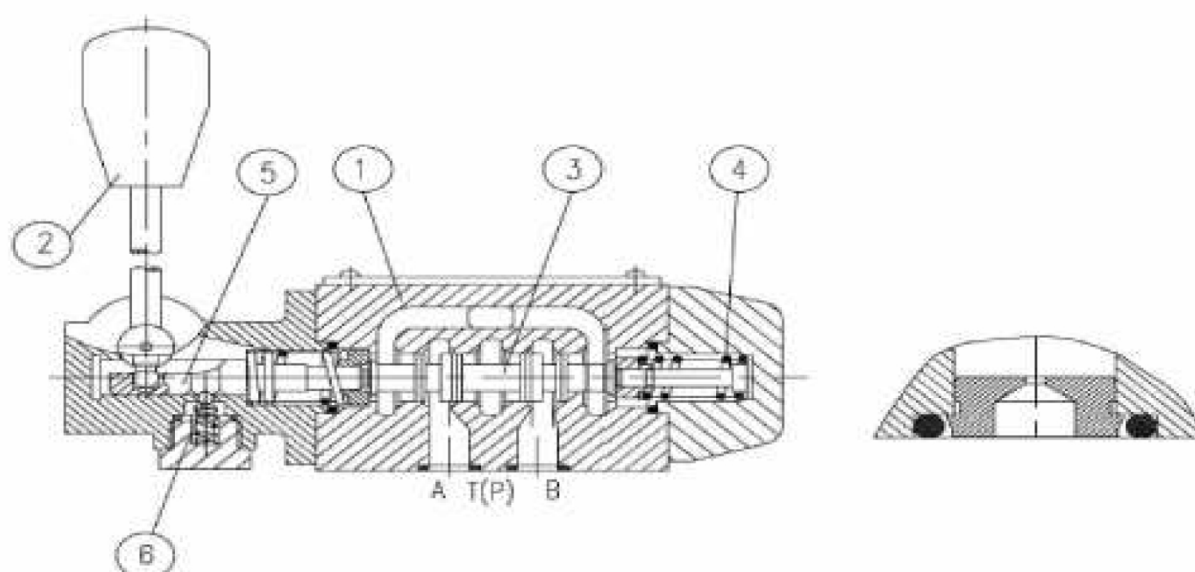

Type 4WMM6

Ordering details

H-	WM	B /	*	
35MPa (Only Size 16, 25)				Further details in clear text
3 service ports = 3				No code = Mineral oils
4 service ports = 4				V = Phosphate ester
Size 6 = 6				Only for Size 6 and 10 No code = Without throttle insert B08 = Throttle ϕ 0.8 mm B10 = Throttle ϕ 1.0 mm B12 = Throttle ϕ 1.2 mm Note: Size 16, 25 without throttle
Size 10 = 10				
Size 16 = 16				
Size 25 = 25				
				No code = Without detent F = With detent
B =				
50 = Series 50 (50 to 59: unchanged installation and connection dimensions) (For Size 6, 16, 25) 10 = Series 10 (10 to 19: unchanged installation and connection dimensions) (For Size 10)				

Example: Spool E on side "a".

Order example: ...EA...

Spool E on side "b".

Order example: ...EB...

- 1) Spool E1: P, A/B, preview port (only for Size 6).
- 2) For Size 10, Spool B, Y, hand lever on side B.
- 3) Spool A and B only for Size 6 and 10.
- 4) Spool K and Z only for Size 16 and 25.

5) Spool S only for Size 16.

6) For Size 16 and 25, spool C is the same as spool H.

For Size 16 and 25, spool D is the same as spool E.

7) Only for Size 16 and 25.

8) Only for Size 16 and 25.

Technical data (For applications outside these parameters, please consult us!)

Size	6	10	16	25
Maximum port A, B, P (MPa)	to31.5		to35	
Working pressure port T (MPa)	to16	to15	to25	to25
Maximum fluid (L/min)	to60	to100	to300	to450
Flow cross section (control position 0)	for symbol Q, 6% of nominal cross section for symbol W, 3% of nominal cross section		for symbol Q, V, 16% of nominal cross section for symbol W, 3% of nominal cross section	
Pressure fluid	Mineral oil or Phosphate ester			
Fluid temperature range (°C)	-30 ~ + 80			
Viscosity range (mm ² /s)	2.8 ~ + 500			
Weight (Kg)	approx.1.4	approx3.3	approx8	approx17
Control power of push lever (N)	Without return pressure approx20 Without return pressure approx30	with detent approx.16-23 without detent approx. 20-27	approx75	approx120

Characteristic curves (measured at $v = 41 \text{ mm}^2 / \text{s}$ and $t = 50 \text{ }^\circ\text{C}$)

Characteristic curves:

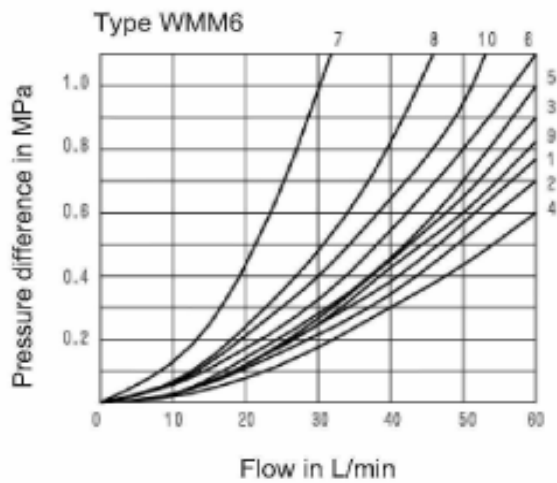

Spool	Shifted position			
	P → A	P → B	A → T	B → T
A	3	3	-	-
B	3	3	-	-
C	1	1	3	1
D	5	5	3	3
E	3	3	1	1
F	1	3	1	1
G	6	6	9	9
H	2	4	2	2
J	1	1	2	1
L	3	3	4	9
M	2	4	3	3
P	3	1	1	1
Q	1	1	2	1
R	5	5	4	1
T	10	10	9	9
U	3	3	9	4
V	1	2	1	1
W	1	1	2	2
Y	5	5	3	3

7 Spool "R" at controller position A to B
8 Spool "G" and "T" at middle position P to T

Characteristic curves: Type WMM10

4 Spool "G" and "T" at middle position P to T
7 Spool "R" at switch position A to B

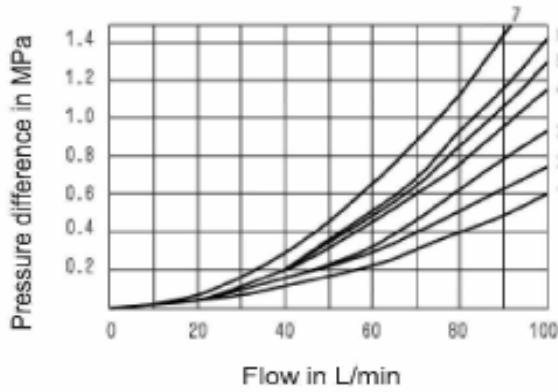

Spool	Shifted position			
	P → A	P → B	A → T	B → T
A	2	2	-	-
B	2	2	-	-
C	2	2	3	3
D	2	2	3	3
E	2	2	4	4
F	2	3	3	5
G	3	3	4	6
H	1	1	4	5
J	2	2	3	3
L	2	2	3	5
M	1	1	5	5
P	3	2	5	3
Q	2	2	4	4
R	2	4	3	-
T	3	5	5	6
U	2	2	3	5
V	2	2	5	5
W	2	2	5	5
Y	2	2	5	3

Characteristic curves: Type WMM16

6 Spool "G" and "T" at middle position P to T
8 Spool "S" at middle position P to T

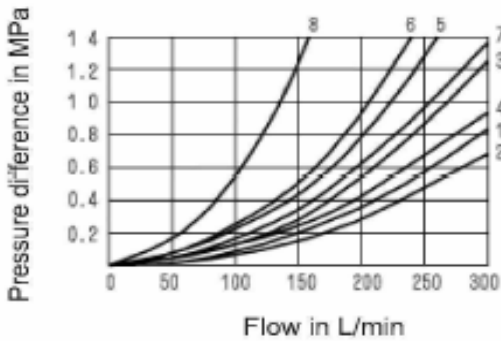

Spool	Shifted position			
	P → A	P → B	A → T	B → T
E, D, Y	1	1	1	3
F	2	2	3	3
G, T	5	1	3	7
H, C, Q	2	2	3	3
V, Z	2	2	3	3
J, K, L	1	1	3	3
M, W	2	2	4	-
R	2	2	4	-
U	1	1	4	7
S	4	4	4	-

Characteristic curves: Type WMM25

4 Spool "L" at A to T
6 Spool "U" at B to T

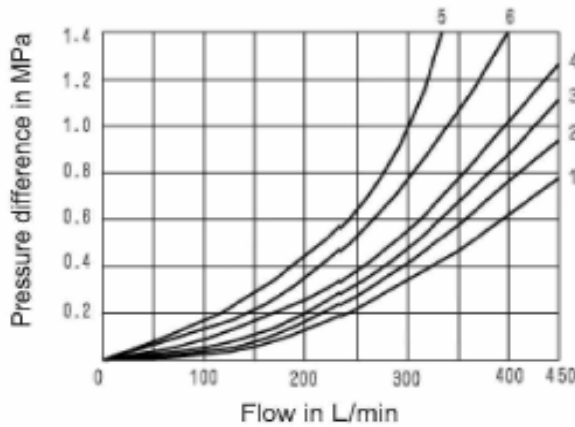

Spool	Shifted position			
	P → A	P → B	A → T	B → T
E	2	2	1	4
F	1	2	1	2
G	2	2	2	4
H	2	2	1	3
J	2	2	1	3
L	2	2	1	2
M	2	2	1	4
P	2	2	1	4
Q	2	2	1	4
R	1	2	1	-
T	2	2	2	4
U	2	2	1	4
V	2	2	1	4
W	2	2	1	3

Performance limits:

The switching function of the valve is, due to the sticking effect, dependent on the filtration. The flow forces acting within the valve also affects the flow performance limits.

For 4-way valves the stated flow data is valid for the normal application case of 2 directions of flow (e.g. from P to A and at the same time return flow from B to T) (see table). If there is only one direction of flow then the permissible flow can be considerably lower, (e.g. when using a 4-way directional valve as a 3-way directional valve with ports A or B plugged).

Performance limits of WMM6:

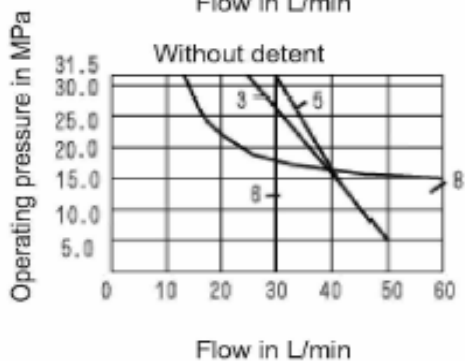
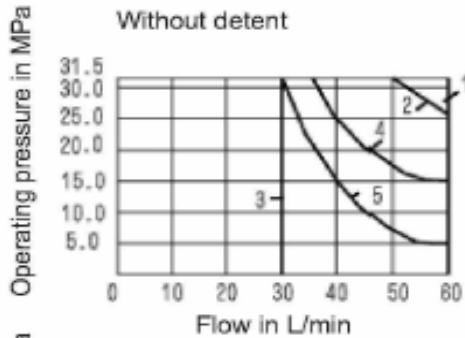

Characteristic curves	Spool	Characteristic curves	Spool
without detent	1	with detent	1
	2		2
	3		3
	4		4
	5		5
	E, E1, H, C, D, M, Q, U, W, G, J, L, R, Y, A, B, V, F, P, T		E1, M, H, C, D, Y, E, J, Q, L, U, W, A, B, G, T, F, V, P, R, T

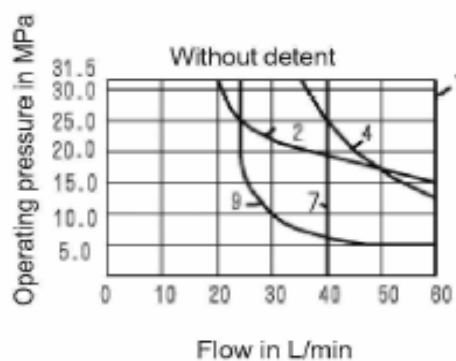

Characteristic curves: Type WMM10

Characteristic curves:	Spool
1	A, B
2	H
3	F, G, P, R, T
4	J, L, Q, U, W
5	C, D, E, M, V, Y

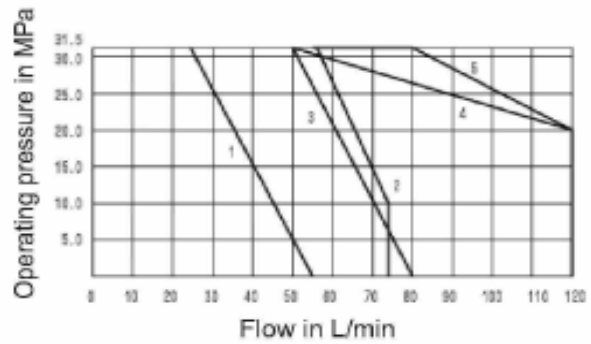

Characteristic curves: Type WMM16

2-position valves , without detent					
flow q_v in L/min	Operating pressure max(MPa)				
Spool	7	14	21	28	35
C	300	300	300	260	220
D	300	300	210	190	160
K	300	300	200	150	130
Z	300	240	190	170	150
3-position valves without detent					
flow q_v in L/min	Operating pressure max(MPa)				
Spool	7	14	21	28	35
E, H, J, L, M Q, R, U, W	300	300	300	300	300
F, P	300	300	210	190	170
G, S, T	300	300	220	210	180
V	300	260	200	180	170

Characteristic curves: Type WMM25

2-position valves , with detent					
flow q_v in L/min	Operating pressure max(MPa)				
Spool	7	14	21	28	35
C, D, K, Z	300	300	300	300	300
3-position valves with detent					
flow q_v in L/min	Operating pressure max(MPa)				
Spool	7	14	21	28	35
E, H, J, L, M Q, R, U, W	300	300	300	300	300
F, P	300	300	280	230	230
G, T, S	300	300	230	230	230
V	300	300	250	230	230

2-position valves without detent					
flow q_v in L/min	Operating pressure max(MPa)				
Spool	7	14	21	28	35
C	450	300	250	200	180
D	350	300	275	250	200
K	200	150	140	130	120
Z	300	270	240	220	200
3-position valves without detent					
flow q_v in L/min	Operating pressure max(MPa)				
Spool	7	14	21	28	35
E, J, L, M Q, R, U, W	450	450	450	450	450
F	450	250	200	135	110
G, T	450	330	290	230	180
H	450	450	400	400	350
P	450	310	240	215	160
V	450	310	280	270	200

2-position valves with detent					
flow q_v in L/min	Operating pressure max(MPa)				
Spool	7	14	21	28	35
C, D, K, Z	450	450	450	450	450
3-position valves with detent					
flow q_v in L/min	Operating pressure max(MPa)				
Spool	7	14	21	28	35
E, F, G, H, J L, M, P, R, T U, W	450	450	450	450	450
V	450	450	400	350	300

Unit dimensions: Type WMM6

(Dimensions in mm)

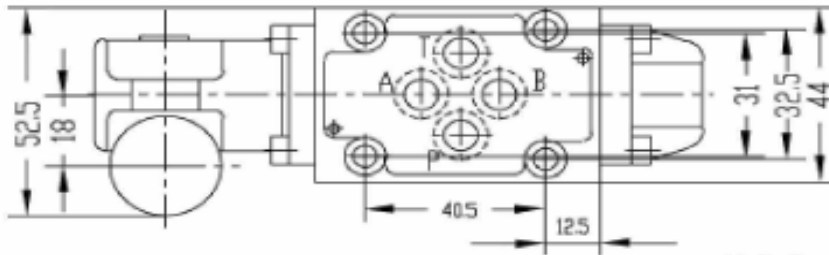
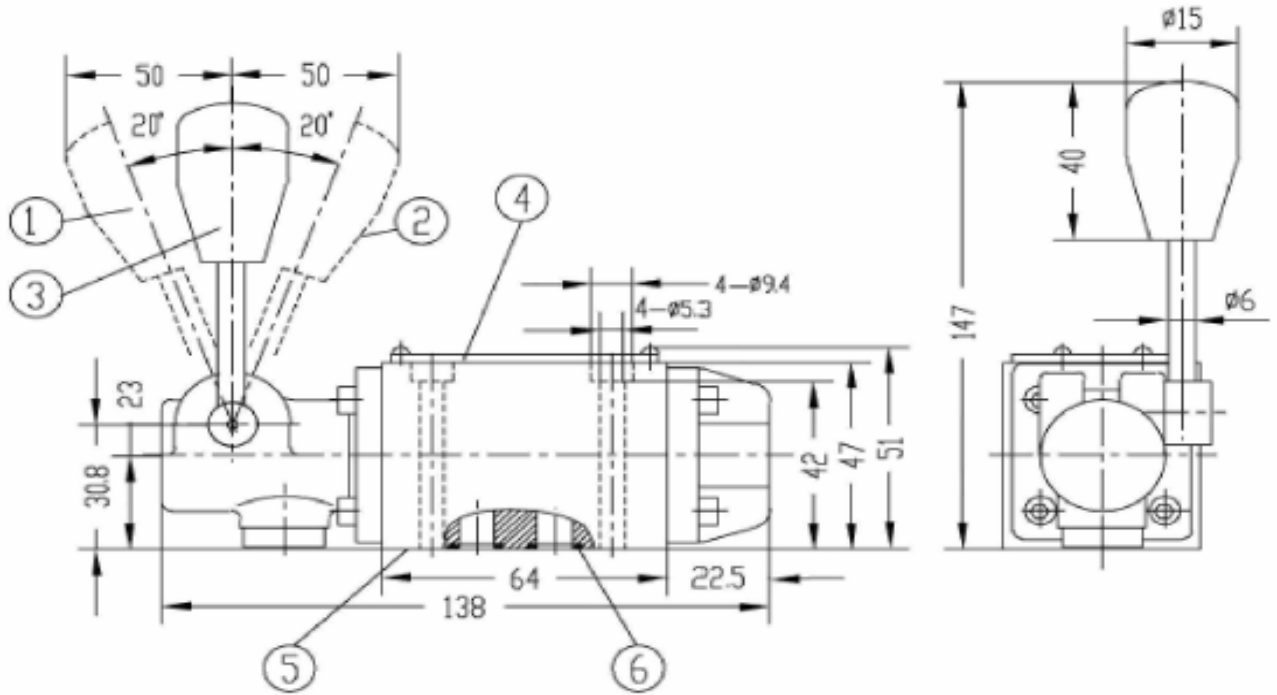

Unit dimensions of ports :

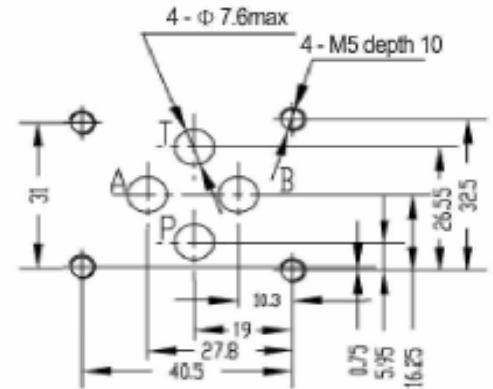
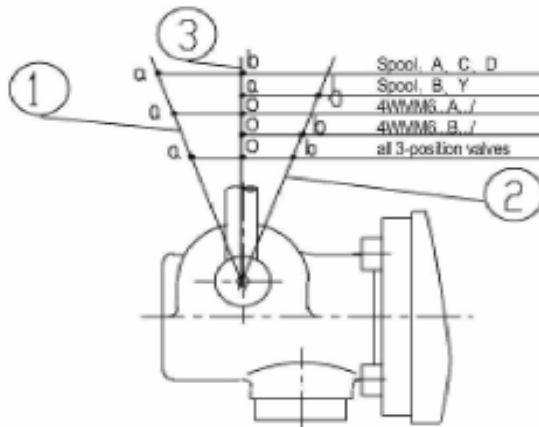

Subplates: see page 205

G341/01 (G1/4"); G341/02 (M14X1.5)

G342/01 (G3/8"); G342/02 (M18X1.5)

G502/01 (G1/2"); G502/02 (M22X1.5)

- 1 Switched position a
- 2 Switched position b
- 3 Switched position 0, a, b
(a and b on 2-position valve)
- 4 Nameplate
- 5 Connection surface
- 6 O-ring 9.25 x 1.78 (for ports A, B, P and T)

Unit dimensions: Type WMM10(with detent)

(Dimensions in mm)

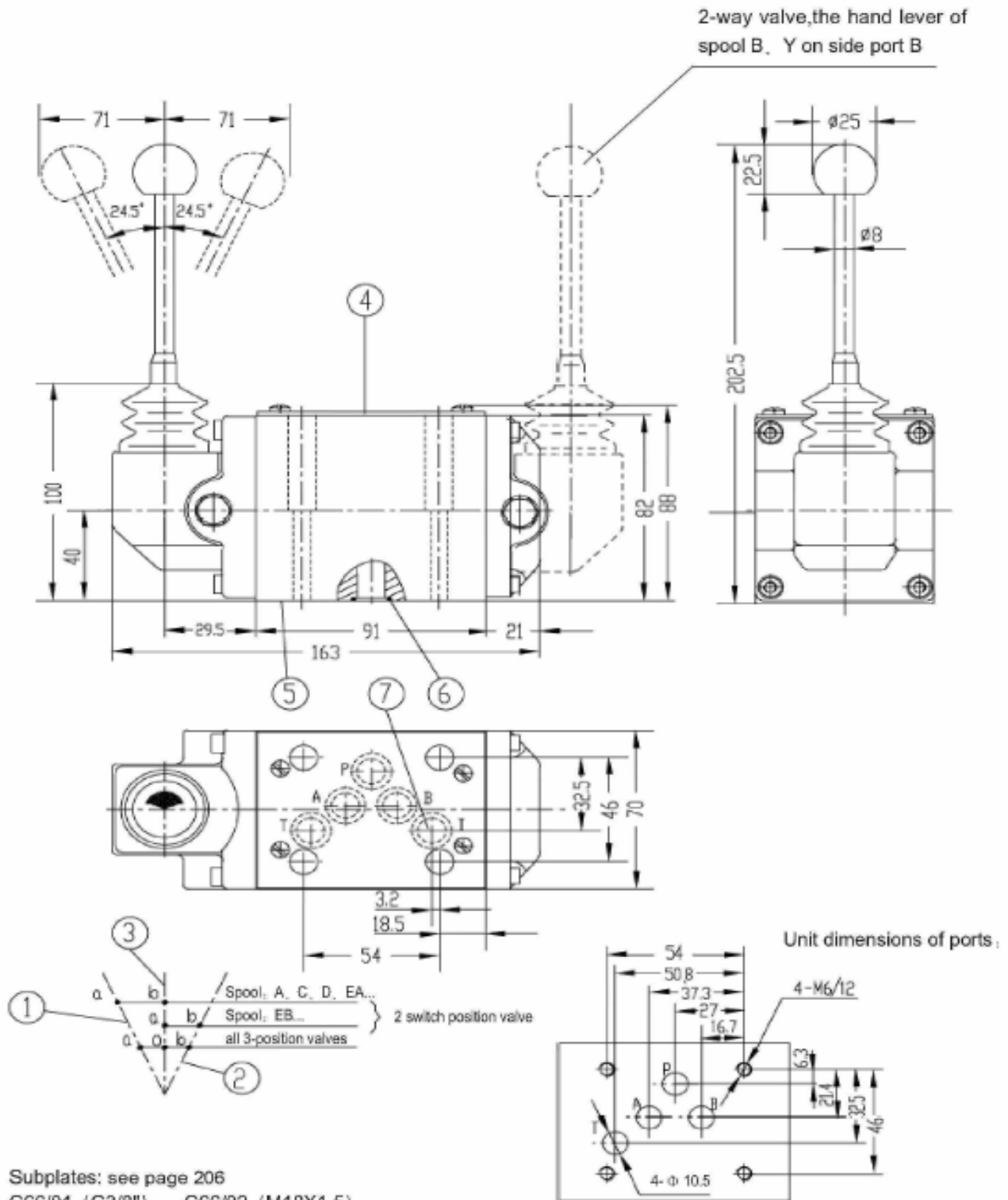

Subplates: see page 206

G66/01 (G3/8"); G66/02 (M18X1.5)

G67/01 (G1/2"); G67/02 (M22X1.5)

G534/01 (G3/4"); G534/02 (M27X2)

1 Switched position a

2 Switched position b

3 Switched position 0, a, b

(a and b on 2-position valve)

4 Nameplate

5 Connection surface

6 O-ring 12 x 2(for ports A, B, P and T)

7 When using control piece, may regarded as

assistant return port

Unit dimensions: Type WMM10(without detent)

(Dimensions in mm)

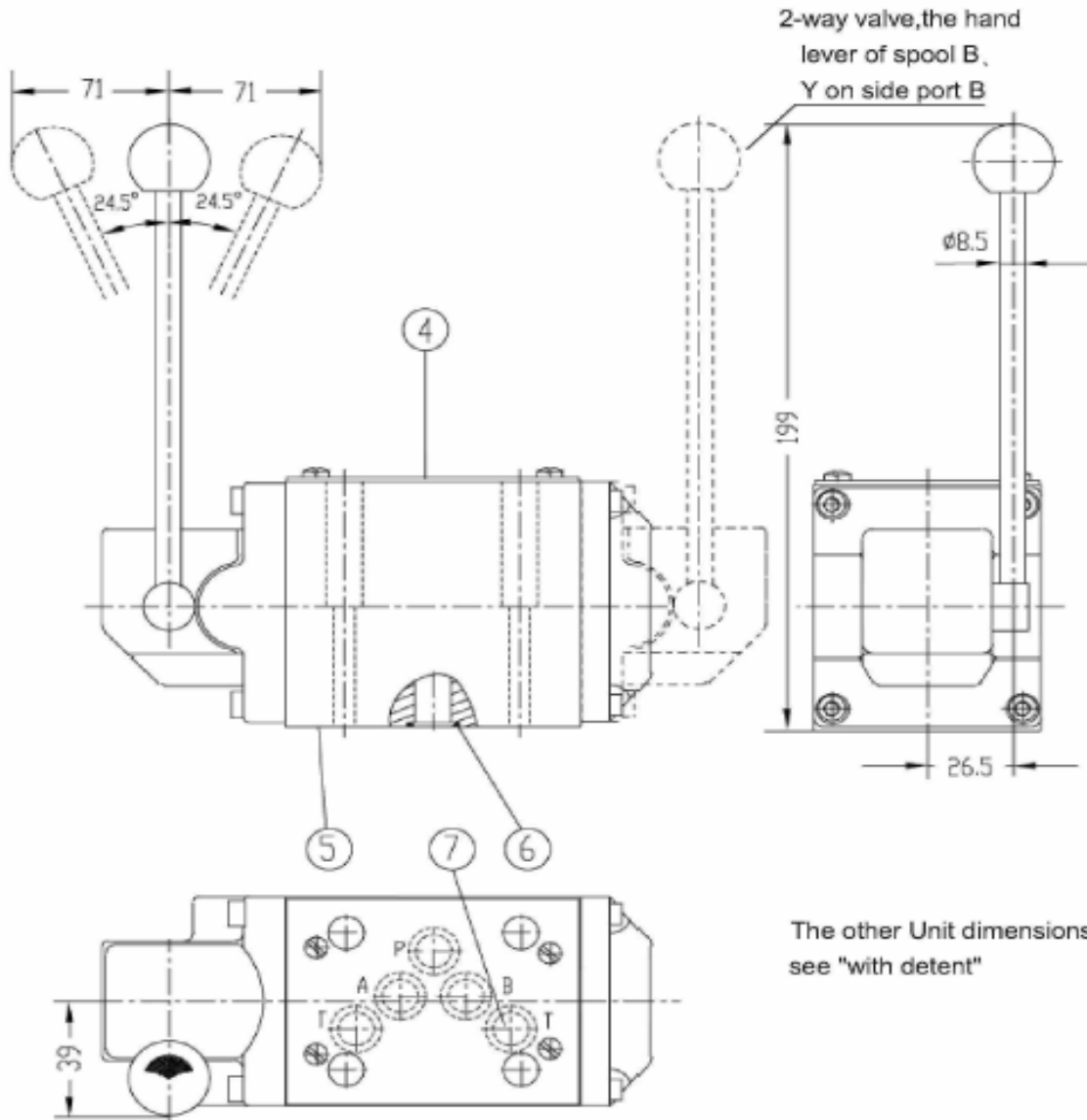

The other Unit dimensions see "with detent"

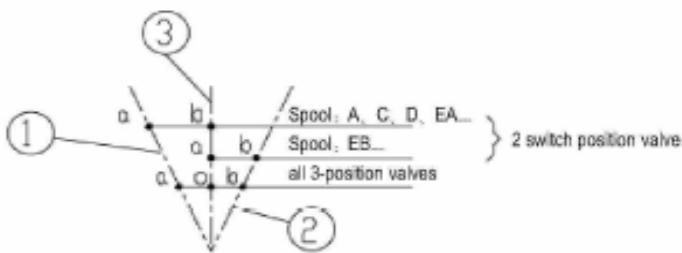

- 1 Switched position a
- 2 Switched position b
- 3 Switched position 0, a, b
(a and b on 2-position valve)
- 4 Nameplate
- 5 Connection surface
- 6 O-ring 12 x 2(for ports A, B, P and T)
- 7 When using control piece,may regarded as assistant return port

Unit dimensions: Type WMM16

(Dimensions in mm)

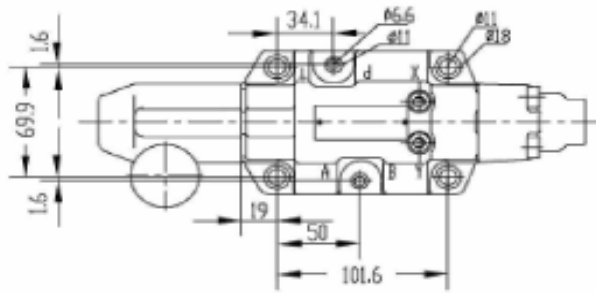
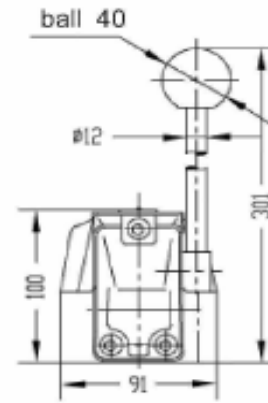
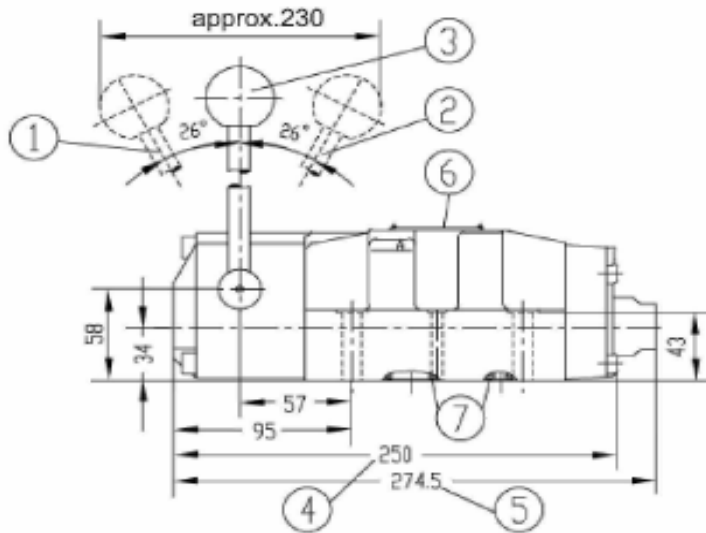

Unit dimensions of ports :

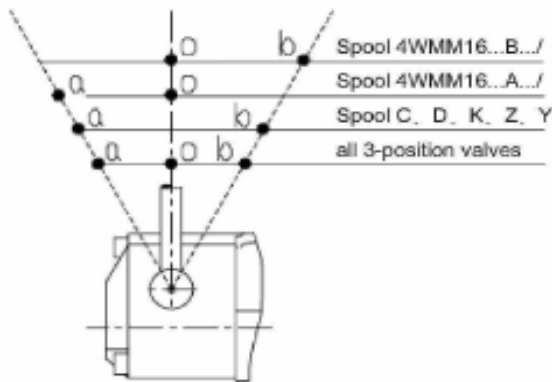
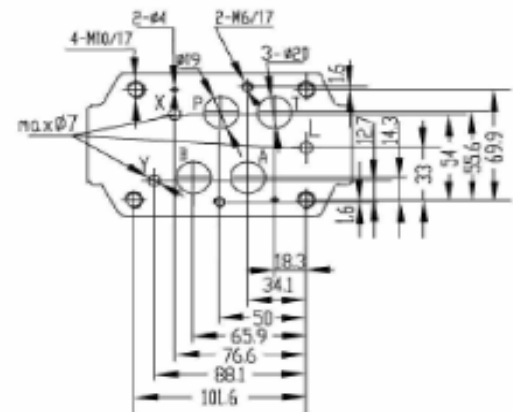

Subplates (see page 207, 208)

G172/01; G172/02

G174/01; G174/02

G174/08

1 Switched position a

2 Switched position b

3 Switched position 0 (a and b on 2-position valve)

4 2-position valve and 3-position valves, with detent.

5 3-position valve, spring-centred

6 2-position valve, without detent

7 Nameplate

8 O-ring 22 x 2.5 (For ports A, B, P and T)

9 O-ring 10 x 2 (For ports X, Y and L)