

APPLICAZIONI

Elettropompe universali per applicazioni civili ed industriali, per impianti di lavaggio ad alta pressione, per l'irrigazione, l'agricoltura, impianti sportivi, per fontane e per movimentazione di liquidi moderatamente aggressivi privi di sostanze solide o abrasive.

LIMITI D'IMPIEGO

- Temperatura liquido fino a 35°C (per un uso domestico secondo EN 60335-2-41)
- Temperatura max. liquido: 110°C (per altri impieghi)
- Temperatura ambiente fino a 40° C

MOTORE

- Monofase 230V-50Hz
- Trifase 230/400V-50Hz
- Motore elettrico ad induzione a 2 poli (n = 2900 min⁻¹)
- Isolamento Classe F
- Protezione IP 55

MATERIALI

- Corpo aspirazione Acciaio Inox AISI 304
- Corpo mandata Acciaio Inox AISI 304
- Girante Acciaio Inox AISI 304
- Camicia pompa Acciaio Inox AISI 304
- Coperchio superiore Acciaio Inox AISI 304
- Coperchio inferiore Acciaio Inox AISI 304
- Albero motore Acciaio Inox AISI 304
- Tenute meccaniche Silicio/Silicio/Viton

OPERATING CONDITIONS

- Liquid temperature up to 35°C (for home use according to EN 60335-2-41)
- Temperature max. liquid: 110°C (for other uses)
- Ambient temperature max to 40°C

MOTOR

- Single-phase 230V-50Hz
- Three-phase 230/400V-50Hz
- Two-pole electric standard motor (n = 2900 min⁻¹)
- Insulation Class F
- Protection IP 55

MATERIALS

- Suction casing Stainless Steel AISI 304
- Delivery casing Stainless Steel AISI 304
- Impeller Stainless Steel AISI 304
- External jacket Stainless Steel AISI 304
- Upper cover Stainless Steel AISI 304
- Lower cover Stainless Steel AISI 304
- Pump shaft Stainless Steel AISI 304
- Mechanical seal Silicon/Silicon/Viton

APPLICATION

Universal pumps for domestic or municipal water supply systems, for clean non-explosive liquids without solid or abrasive substances, for agricultural irrigation and sports application, for civil and industrial use, boiler feeding and condensate systems and for high pressure washing plants.



TIPO TYPE		POTENZA NOMINALE NOMINAL POWER		AMPERE		Q = PORTATA - CAPACITY										
Monofase Single-phase	Trifase Three-phase	P2		Monofase Single-phase	Trifase Three-phase	m ³ /h	1	1,2	1,5	1,6	2	2,4	2,8	3	3,2	3,5
		HP	kW			lt/1'	16	20	25	26	33	40	46	50	53	58
Prevalenza manometrica totale in m.C.A. - Total head in meters w.c.																
VSM 2-4	VS 2-4	0,75	0,55	3,4	1,4	H (m)	36	34	32,5	32	29	26,5	23,5	21,5	20	16
VSM 2-5	VS 2-5	0,75	0,55	3,4	1,4		45	43	40,5	40	37	33	30	26	23,5	20
VSM 2-7	VS 2-7	1	0,75	5	1,7		63	60	57,5	57	52	47	42	38	35	28
VSM 2-11	VS 2-11	1,5	1,1	6,9	2,5		98	94	89,5	89	80	73	64	58	53	44
VSM 2-15	VS 2-15	2	1,5	9,7	3,5		134	130	124,5	124	114	104	94	86	78	60
VSM 2-18	VS 2-18	3	2,2	13,5	4,7		161	157	150,5	150	140	129	118	104	93	76
VSM 2-22	VS 2-22	3	2,2	13,5	4,7		197	191	180,5	180	165	150	135	123	110	90
	VS 2-26	4	3		6,1		232	224	214,5	214	190	175	158	144	130	110

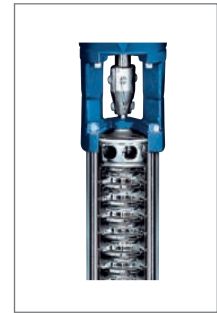
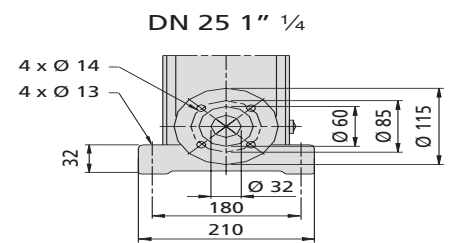
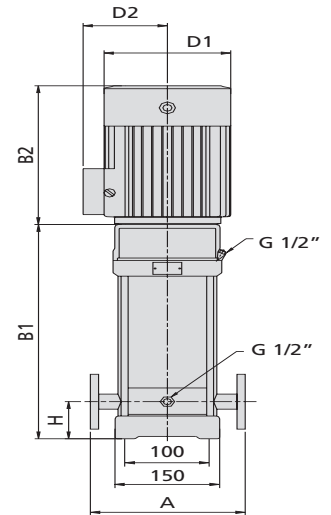
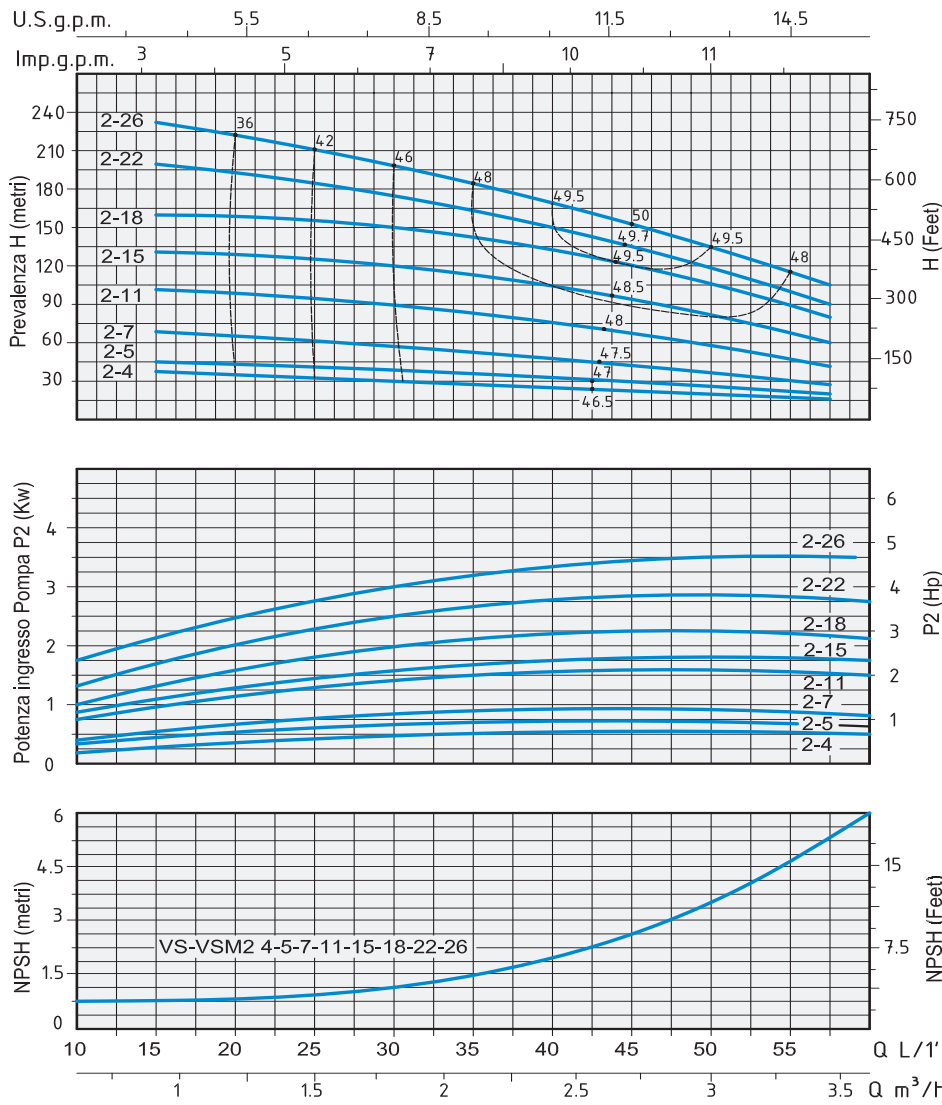

TIPO TYPE		DIMENSIONI mm - DIMENSIONS mm							DIMENSIONI DIMENSIONS mm			PESO WEIGHT	
Monofase Single-phase	Trifase Three-phase	A	H	B1	B2	B1 + B2	D1	D2	FLANGIA FLANGE	P	L	H	Kg
VSM 2-4	VS 2-4	250	75	294	210	504	148	117	DN 25 1" 1/4	320	765	395	34
VSM 2-5	VS 2-5	250	75	312	210	522	148	117	DN 25 1" 1/4	320	765	395	34,1
VSM 2-7	VS 2-7	250	75	358	245	603	170	142	DN 25 1" 1/4	320	765	395	38,1
VSM 2-11	VS 2-11	250	75	430	245	675	170	142	DN 25 1" 1/4	320	765	395	42,1
VSM 2-15	VS 2-15	250	75	512	290	802	190	155	DN 25 1" 1/4	372	965	445	50,9
VSM 2-18	VS 2-18	250	75	566	290	856	190	155	DN 25 1" 1/4	372	965	445	55
VSM 2-22	VS 2-22	250	75	638	290	928	190	155	DN 25 1" 1/4	365	1115	440	59,4
	VS 2-26	250	75	720	315	1035	197	165	DN 25 1" 1/4	365	1115	440	66,1

APPLICAZIONI

Elettropompe universali per applicazioni civili ed industriali, per impianti di lavaggio ad alta pressione, per l'irrigazione, l'agricoltura, impianti sportivi, per fontane e per movimentazione di liquidi moderatamente aggressivi privi di sostanze solide o abrasive.

LIMITI D'IMPIEGO

- Temperatura liquido fino a 35°C (per un uso domestico secondo EN 60335-2-41)
- Temperatura max. liquido: 110°C (per altri impieghi)
- Temperatura ambiente fino a 40° C

MOTORE

- Monofase 230V-50Hz
- Trifase 230/400V-50Hz
- Motore elettrico ad induzione a 2 poli (n = 2900 min⁻¹)
- Isolamento Classe F
- Protezione IP 55

MATERIALI

- Corpo aspirazione Acciaio Inox AISI 304
- Corpo mandata Acciaio Inox AISI 304
- Girante Acciaio Inox AISI 304
- Camicia pompa Acciaio Inox AISI 304
- Coperchio superiore Acciaio Inox AISI 304
- Coperchio inferiore Acciaio Inox AISI 304
- Albero motore Acciaio Inox AISI 304
- Tenute meccaniche Silicio/Silicio/Viton

OPERATING CONDITIONS

- Liquid temperature up to 35°C (for home use according to EN 60335-2-41)
- Temperature max. liquid: 110°C (for other uses)
- Ambient temperature max to 40°C

MOTOR

- Single-phase 230V-50Hz
- Three-phase 230/400V-50Hz
- Two-pole electric standard motor (n = 2900 min⁻¹)
- Insulation Class F
- Protection IP 55

MATERIALS

- Suction casing Stainless Steel AISI 304
- Delivery casing Stainless Steel AISI 304
- Impeller Stainless Steel AISI 304
- External jacket Stainless Steel AISI 304
- Upper cover Stainless Steel AISI 304
- Lower cover Stainless Steel AISI 304
- Pump shaft Stainless Steel AISI 304
- Mechanical seal Silicon/Silicon/Viton

APPLICATION

Universal pumps for domestic or municipal water supply systems, for clean non-explosive liquids without solid or abrasive substances, for agricultural irrigation and sports application, for civil and industrial use, boiler feeding and condensate systems and for high pressure washing plants.



TIPO TYPE		POTENZA NOMINALE NOMINAL POWER		AMPERE		Q = PORTATA - CAPACITY										
Monofase Single-phase	Trifase Three-phase	P2		Monofase Single-phase	Trifase Three-phase	m ³ /h	1,5	2	2,4	3	3,5	4	5	6	7	8
		HP	kW			lt/1'	25	33	40	50	58	66	83	100	116	133
VSM 4-3	VS 4-3	0,75	0,55	3,4	1,4	H (m)	28	27	26,5	25,5	24,5	23,5	21	18	14	10
VSM 4-4	VS 4-4	1	0,75	5	1,7		38	36	35,5	34,5	33,5	32	29	24,5	19	13
VSM 4-6	VS 4-6	1,5	1,1	6,9	2,5		56	54,5	53,5	52	50	48	42	36	28,5	20
VSM 4-8	VS 4-8	2	1,5	9,7	3,5		74	73	72	70	68	66	60	52	42	27
VSM 4-12	VS 4-12	3	2,2	13,5	4,7		114	110	107,5	104	101	96	87	74	59	41
	VS 4-16	4	3		6,1		152	149,5	146,5	142	137	131,5	118	101	80	55
	VS 4-19	5,5	4		8		183	179	175	168	163	158	143	124	100	67
	VS 4-22	5,5	4		8		211	205	200	194	188	181	164	142	116	79

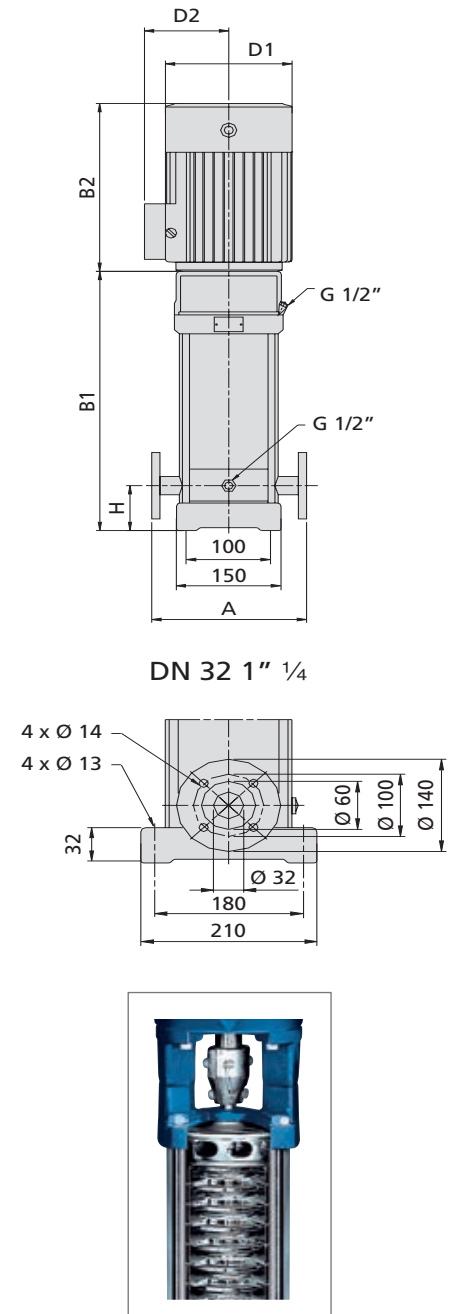
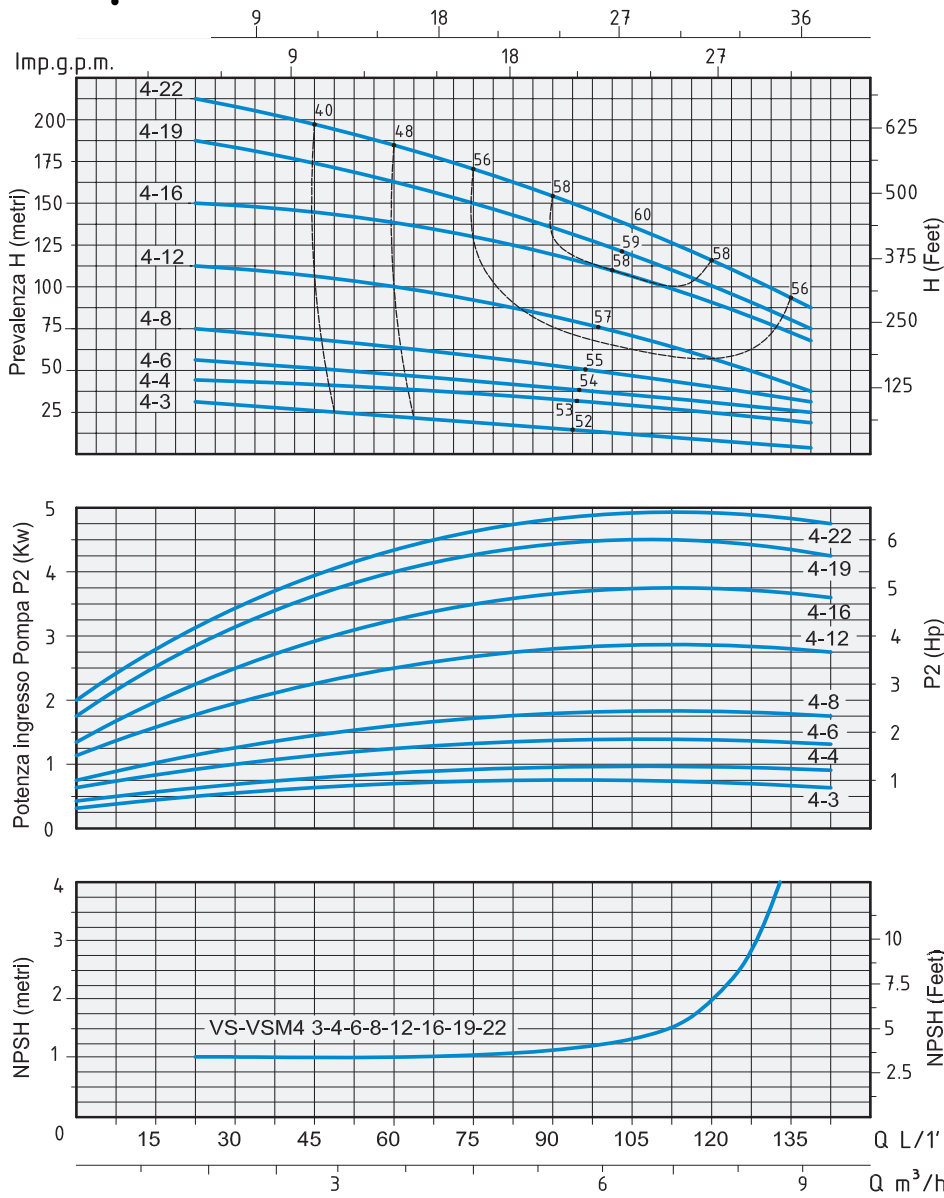

TIPO TYPE		DIMENSIONI mm - DIMENSIONS mm							DIMENSIONI DIMENSIONS mm			PESO WEIGHT	
Monofase Single-phase	Trifase Three-phase	A	H	B1	B2	B1 + B2	D1	D2	FLANGIA FLANGE	P	L	H	Kg
VSM 4-3	VS 4-3	250	75	303	210	513	148	148	DN 32 1" 1/4	320	765	395	37,1
VSM 4-4	VS 4-4	250	75	340	245	585	170	142	DN 32 1" 1/4	320	765	395	39
VSM 4-6	VS 4-6	250	75	394	245	639	170	142	DN 32 1" 1/4	320	765	395	44,1
VSM 4-8	VS 4-8	250	75	458	290	748	190	155	DN 32 1" 1/4	372	965	445	52,1
VSM 4-12	VS 4-12	250	75	566	290	856	190	155	DN 32 1" 1/4	372	965	445	57,1
	VS 4-16	250	75	684	315	999	197	165	DN 32 1" 1/4	365	1115	440	64,1
	VS 4-19	250	75	765	335	1100	230	188	DN 32 1" 1/4	417	1215	445	78,5
	VS 4-22	250	75	846	335	1181	230	188	DN 32 1" 1/4	417	1215	445	81,8

APPLICAZIONI

Elettropompe universali per applicazioni civili ed industriali, per impianti di lavaggio ad alta pressione, per l'irrigazione, l'agricoltura, impianti sportivi, per fontane e per movimentazione di liquidi moderatamente aggressivi privi di sostanze solide o abrasive.

LIMITI D'IMPIEGO

- Temperatura liquido fino a 35°C (per un uso domestico secondo EN 60335-2-41)
- Temperatura max. liquido: 110°C (per altri impieghi)
- Temperatura ambiente fino a 40° C

MOTORE

- Monofase 230V-50Hz
- Trifase 230/400V-50Hz P2 ≤ 7,5 kW
- Trifase 400/690V-50Hz P2 > 7,5 kW
- Motore elettrico ad induzione a 2 poli (n = 2900 min⁻¹)
- Isolamento Classe F
- Protezione IP 55

MATERIALI

- Corpo aspirazione Acciaio Inox AISI 304
- Corpo mandata Acciaio Inox AISI 304
- Girante Acciaio Inox AISI 304
- Camicia pompa Acciaio Inox AISI 304
- Coperchio superiore Acciaio Inox AISI 304
- Coperchio inferiore Acciaio Inox AISI 304
- Albero motore Acciaio Inox AISI 304
- Tenute meccaniche Silicio/Silicio/Viton

OPERATING CONDITIONS

- Liquid temperature up to 35°C (for home use according to EN 60335-2-41)
- Temperature max. liquid: 110°C (for other uses)
- Ambient temperature max to 40°C

MOTOR

- Single-phase 230V-50Hz
- Three-phase 230/400V-50Hz P2 ≤ 7,5 kW
- Three-phase 400/690V-50Hz P2 > 7,5 kW
- Two-pole electric standard motor (n = 2900 min⁻¹)
- Insulation Class F
- Protection IP 55

MATERIALS

- Suction casing Stainless Steel AISI 304
- Delivery casing Stainless Steel AISI 304
- Impeller Stainless Steel AISI 304
- External jacket Stainless Steel AISI 304
- Upper cover Stainless Steel AISI 304
- Lower cover Stainless Steel AISI 304
- Pump shaft Stainless Steel AISI 304
- Mechanical seal Silicon/Silicon/Viton

APPLICATION

Universal pumps for domestic or municipal water supply systems, for clean non-explosive liquids without solid or abrasive substances, for agricultural irrigation and sports application, for civil and industrial use, boiler feeding and condensate systems and for high pressure washing plants.



TIPO TYPE		POTENZA NOMINALE NOMINAL POWER		AMPERE		Q = PORTATA - CAPACITY								
Monofase Single-phase	Trifase Three-phase	P2		Monofase Single-phase	Trifase Three-phase	m ³ /h	5	6	7	8	9	10	11	12
		HP	kW			lt/1'	83	100	116	133	150	166	183	200
Prevalenza manometrica totale in m.C.A. - Total head in meters w.c.														
VSM 8-3	VS 8-3	1,5	1,1	6,9	2,5	H (m)	30	29	28	26	24	22	20	19
VSM 8-4	VS 8-4	2	1,5	9,7	3,5		41	38	37	35	33	31	27	26
VSM 8-6	VS 8-6	3	2,2	13,5	4,7		62	58	56	53	49	46	41	39
	VS 8-8	4	3		6,1		83	79	76	73	68	64	57	52
	VS 8-10	5,5	4		8		104	100	97	93	87	81	73	65
	VS 8-15	7,5	5,5		10,7		155	148	146	136	127	117	106	99
	VS 8-19	10	7,5		14,5		197	193	185	175	163	150	132	127
	VS 8-20	10	7,5		14,5		208	200	190	180	170	157	145	135

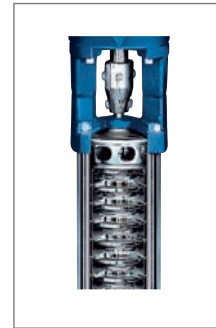
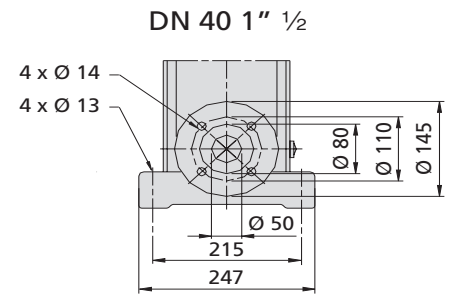
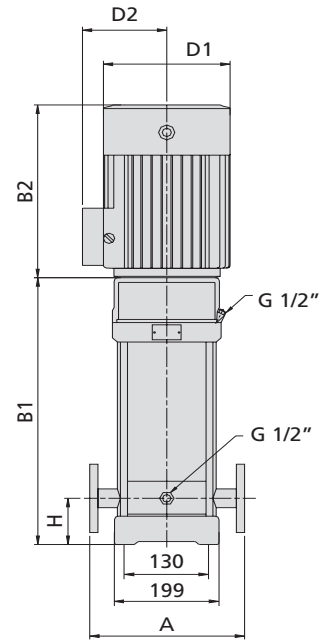
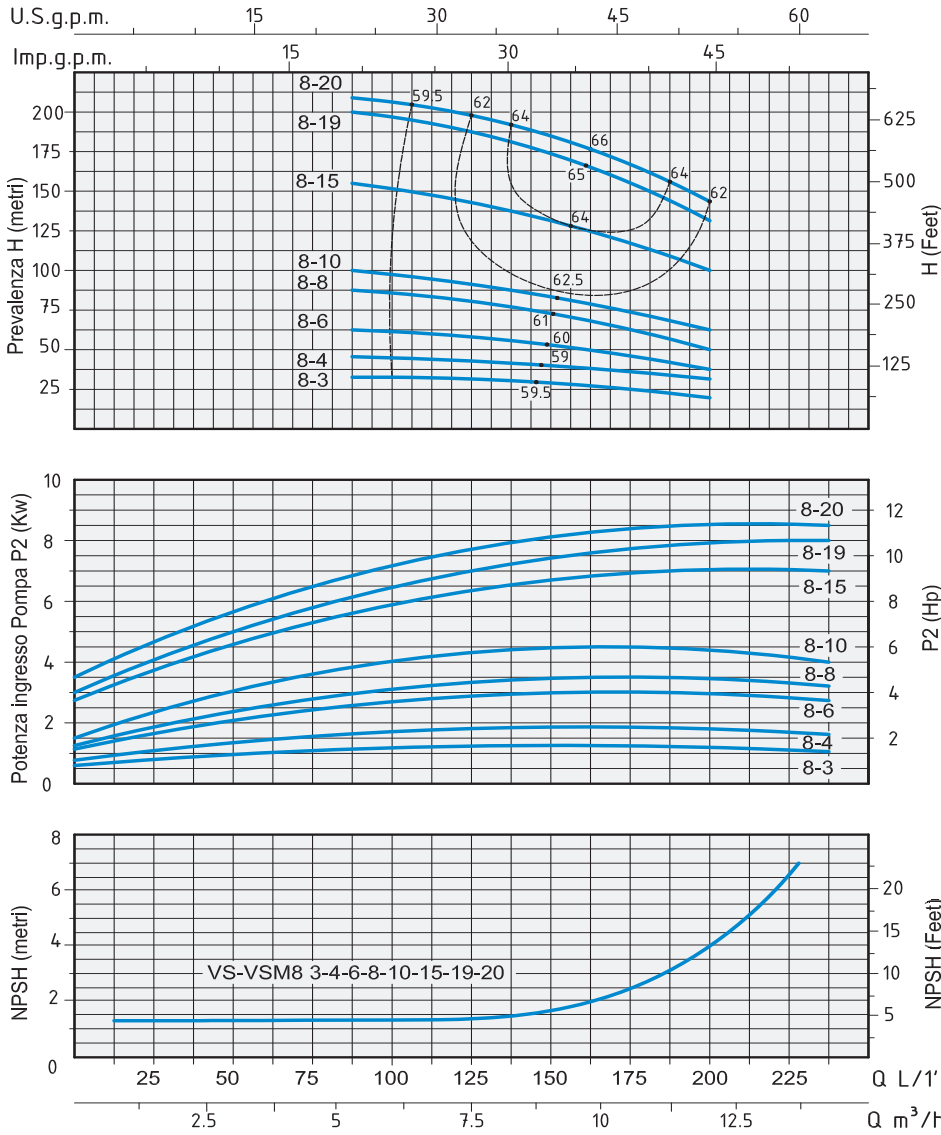

TIPO TYPE		DIMENSIONI mm - DIMENSIONS mm							DIMENSIONI DIMENSIONS mm			PESO WEIGHT	
Monofase Single-phase	Trifase Three-phase	A	H	B1	B2	B1 + B2	D1	D2	FLANGIA FLANGE	P	L	H	Kg
VSM 8-3	VS 8-3	280	80	377	245	622	170	142	DN 40 1" 1/2	320	765	395	51,8
VSM 8-4	VS 8-4	280	80	417	290	707	190	155	DN 40 1" 1/2	372	965	445	62
VSM 8-6	VS 8-6	280	80	477	290	767	190	155	DN 40 1" 1/2	372	965	445	63
	VS 8-8	280	80	547	315	862	197	165	DN 40 1" 1/2	372	965	445	67,6
	VS 8-10	280	80	607	335	942	230	188	DN 40 1" 1/2	365	1115	440	82,8
	VS 8-15	280	80	807	430	1237	260	208	DN 40 1" 1/2	417	1215	445	104,7
	VS 8-19	280	80	867	430	1297	260	208	DN 40 1" 1/2	515	1515	493	123,1
	VS 8-20	280	80	927	430	1357	260	208	DN 40 1" 1/2	515	1515	493	125,1

APPLICAZIONI

Elettropompe universali per applicazioni civili ed industriali, per impianti di lavaggio ad alta pressione, per l'irrigazione, l'agricoltura, impianti sportivi, per fontane e per movimentazione di liquidi moderatamente aggressivi privi di sostanze solide o abrasive.

LIMITI D'IMPIEGO

- Temperatura liquido fino a 35°C (per un uso domestico secondo EN 60335-2-41)
- Temperatura max. liquido: 110°C (per altri impieghi)
- Temperatura ambiente fino a 40° C

MOTORE

- Monofase 230V-50Hz
- Trifase 230/400V-50Hz P2 ≤ 7,5 kW
- Trifase 400/690V-50Hz P2 > 7,5 kW
- Motore elettrico ad induzione a 2 poli (n = 2900 min⁻¹)
- Isolamento Classe F
- Protezione IP 55

MATERIALI

- Corpo aspirazione Acciaio Inox AISI 304
- Corpo mandata Acciaio Inox AISI 304
- Girante Acciaio Inox AISI 304
- Camicia pompa Acciaio Inox AISI 304
- Coperchio superiore Acciaio Inox AISI 304
- Coperchio inferiore Acciaio Inox AISI 304
- Albero motore Acciaio Inox AISI 304
- Tenute meccaniche Silicio/Silicio/Viton

OPERATING CONDITIONS

- Liquid temperature up to 35°C (for home use according to EN 60335-2-41)
- Temperature max. liquid: 110°C (for other uses)
- Ambient temperature max to 40°C

MOTOR

- Single-phase 230V-50Hz
- Three-phase 230/400V-50Hz P2 ≤ 7,5 kW
- Three-phase 400/690V-50Hz P2 > 7,5 kW
- Two-pole electric standard motor (n = 2900 min⁻¹)
- Insulation Class F
- Protection IP 55

MATERIALS

- Suction casing Stainless Steel AISI 304
- Delivery casing Stainless Steel AISI 304
- Impeller Stainless Steel AISI 304
- External jacket Stainless Steel AISI 304
- Upper cover Stainless Steel AISI 304
- Lower cover Stainless Steel AISI 304
- Pump shaft Stainless Steel AISI 304
- Mechanical seal Silicon/Silicon/Viton

APPLICATION

Universal pumps for domestic or municipal water supply systems, for clean non-explosive liquids without solid or abrasive substances, for agricultural irrigation and sports application, for civil and industrial use, boiler feeding and condensate systems and for high pressure washing plants.



TIPO TYPE		POTENZA NOMINALE NOMINAL POWER		AMPERE		Q = PORTATA - CAPACITY										
Monofase Single-phase	Trifase Three-phase	P2		Monofase Single-phase	Trifase Three-phase	m ³ /h	8	9	10	11	12	14	16	18	20	22
		HP	kW			lt/1'	133	150	166	183	200	233	266	300	333	366
VSM 16-2	VS 16-2	3	2,2	13,5	4,7	H (m)	27	26,5	26	25,5	25	24,5	23,5	22	20	16
	VS 16-3	4	3		6,1		41	40,5	40	39,5	39	37,5	35,5	33	30	25
	VS 16-4	5,5	4		8		54	53	52	51	50	49	46	43	38	34
	VS 16-6	7,5	5,5		10,7		82	81	80	78	77	73	69	63	57	52
	VS 16-8	10	7,5		14,5		110	109,5	109	108,5	108	104	101	95	85	70
	VS 16-12	15	11		19,4		166	163	161	158	155	149	140	130	118	105
	VS 16-16	20	15		26		222	220	218	214	210	202	191	178	162	140
Prevalenza manometrica totale in m.C.A. - Total head in meters w.c.																

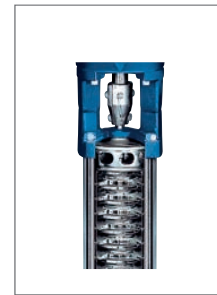
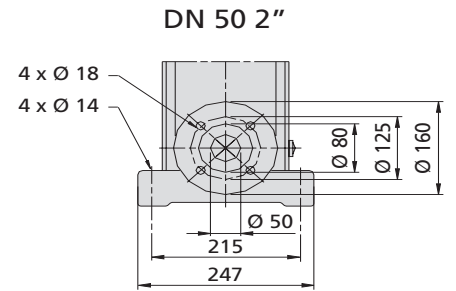
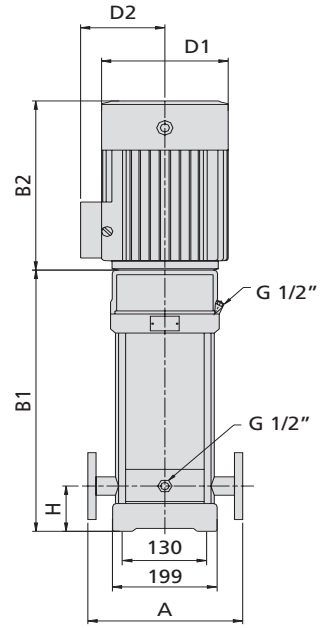
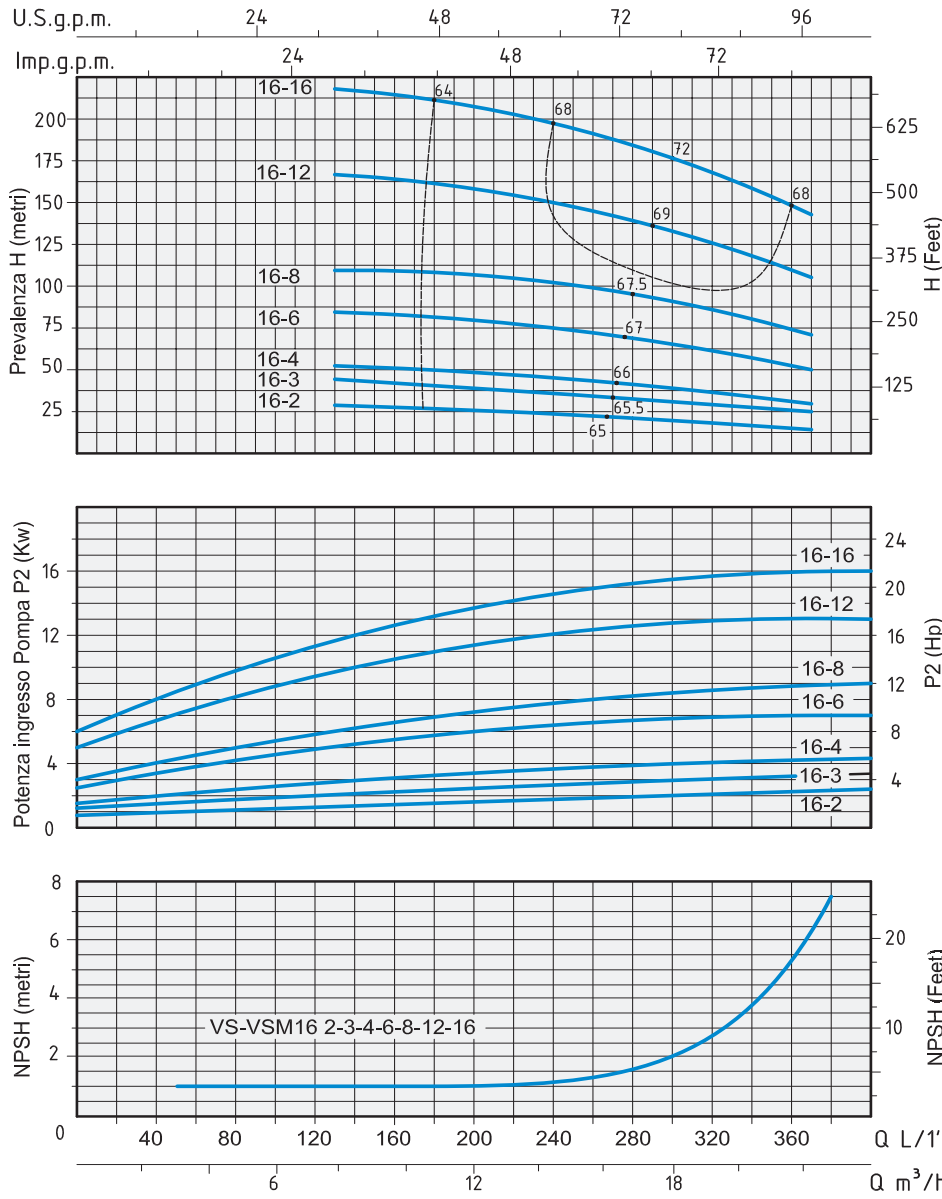

TIPO TYPE		DIMENSIONI mm - DIMENSIONS mm							DIMENSIONI DIMENSIONS mm			PESO WEIGHT	
Monofase Single-phase	Trifase Three-phase	A	H	B1	B2	B1 + B2	D1	D2	FLANGIA FLANGE	P	L	H	Kg
VSM 16-2	VS 16-2	300	90	397	290	687	190	155	DN 50 2"	365	1115	440	63,5
	VS 16-3	300	90	452	315	767	197	165	DN 50 2"	372	965	445	69,5
	VS 16-4	300	90	497	335	832	230	188	DN 50 2"	372	965	445	78,2
	VS 16-6	300	90	607	430	1037	260	208	DN 50 2"	365	1115	440	99,1
	VS 16-8	300	90	697	430	1127	260	208	DN 50 2"	417	1215	445	109,6
	VS 16-12	300	90	965	490	1455	330	255	DN 50 2"	515	1515	493	196,5
	VS 16-16	300	90	1145	490	1635	330	255	DN 50 2"	515	1715	490	214,5

APPLICAZIONI

Elettropompe universali per applicazioni civili ed industriali, per impianti di lavaggio ad alta pressione, per l'irrigazione, l'agricoltura, impianti sportivi, per fontane e per movimentazione di liquidi moderatamente aggressivi privi di sostanze solide o abrasive.

LIMITI D'IMPIEGO

- Temperatura liquido fino a 35°C (per un uso domestico secondo EN 60335-2-41)
- Temperatura max. liquido: 110°C (per altri impieghi)
- Temperatura ambiente fino a 40°C

MOTORE

- Trifase 230/400V-50Hz P2 ≤ 7,5 kW
- Trifase 400/690V-50Hz P2 > 7,5 kW
- Motore elettrico ad induzione a 2 poli (n = 2900 min⁻¹)
- Isolamento Classe F
- Protezione IP 55

MATERIALI

- Corpo aspirazione Acciaio Inox AISI 304
- Corpo mandata Acciaio Inox AISI 304
- Girante Acciaio Inox AISI 304
- Camicia pompa Acciaio Inox AISI 304
- Coperchio superiore Acciaio Inox AISI 304
- Coperchio inferiore Acciaio Inox AISI 304
- Albero motore Acciaio Inox AISI 304
- Tenute meccaniche Silicio/Silicio/Viton

OPERATING CONDITIONS

- Liquid temperature up to 35°C (for home use according to EN 60335-2-41)
- Temperature max. liquid: 110°C (for other uses)
- Ambient temperature max to 40°C

MOTOR

- Three-phase 230/400V-50Hz P2 ≤ 7,5 kW
- Three-phase 400/690V-50Hz P2 > 7,5 kW
- Two-pole electric standard motor (n = 2900 min⁻¹)
- Insulation Class F
- Protection IP 55

MATERIALS

- Suction casing Stainless Steel AISI 304
- Delivery casing Stainless Steel AISI 304
- Impeller Stainless Steel AISI 304
- External jacket Stainless Steel AISI 304
- Upper cover Stainless Steel AISI 304
- Lower cover Stainless Steel AISI 304
- Pump shaft Stainless Steel AISI 304
- Mechanical seal Silicon/Silicon/Viton

APPLICATION

Universal pumps for domestic or municipal water supply systems, for clean non-explosive liquids without solid or abrasive substances, for agricultural irrigation and sports application, for civil and industrial use, boiler feeding and condensate systems and for high pressure washing plants.



TIPO TYPE	POTENZA NOMINALE NOMINAL POWER		AMPERE	Q = PORTATA - CAPACITY										
	P2			m ³ /h	16	20	22	24	26	28	30	32	35	40
Trifase Three-phase	HP	kW	Trifase Three-phase											
				Prevalenza manometrica totale in m.C.A. - Total head in meters w.c.										
VS 32-3	7,5	5,5	10,7	H (m)	54	51	49	48	46	44	42	36	35	27
VS 32-4	10	7,5	14,5		72	69	67	65	63	60	57	49	48	37
VS 32-5	15	11	16		90	86	84	81,5	79	76	72	63	61	47
VS 32-6	15	11	19,4		108	106	103	100	97	93	89	79	77	57
VS 32-8	20	15	24,5		144	139	135,5	132	127	122	117	102	100	77
VS 32-10	25	18,5	32		182	175	171	166	160	153	145	124	120	98

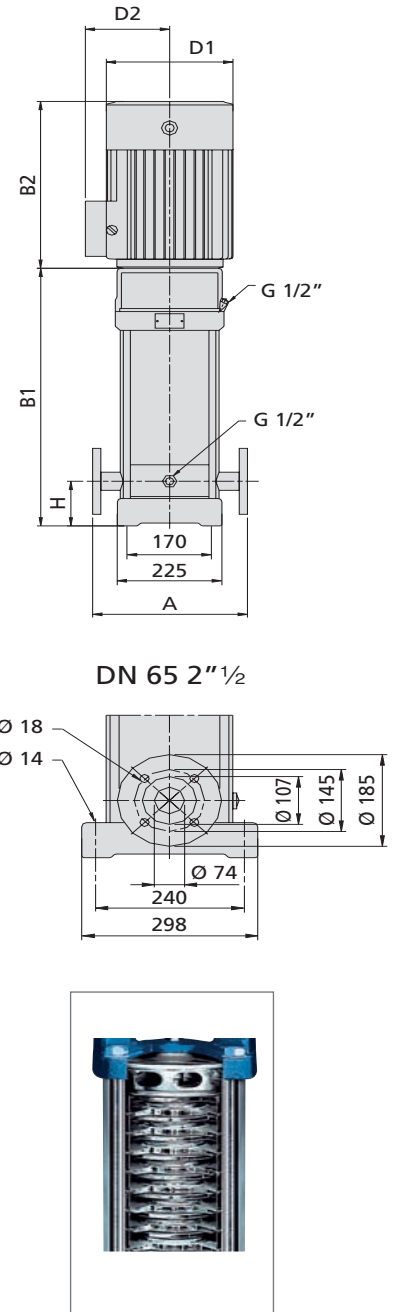
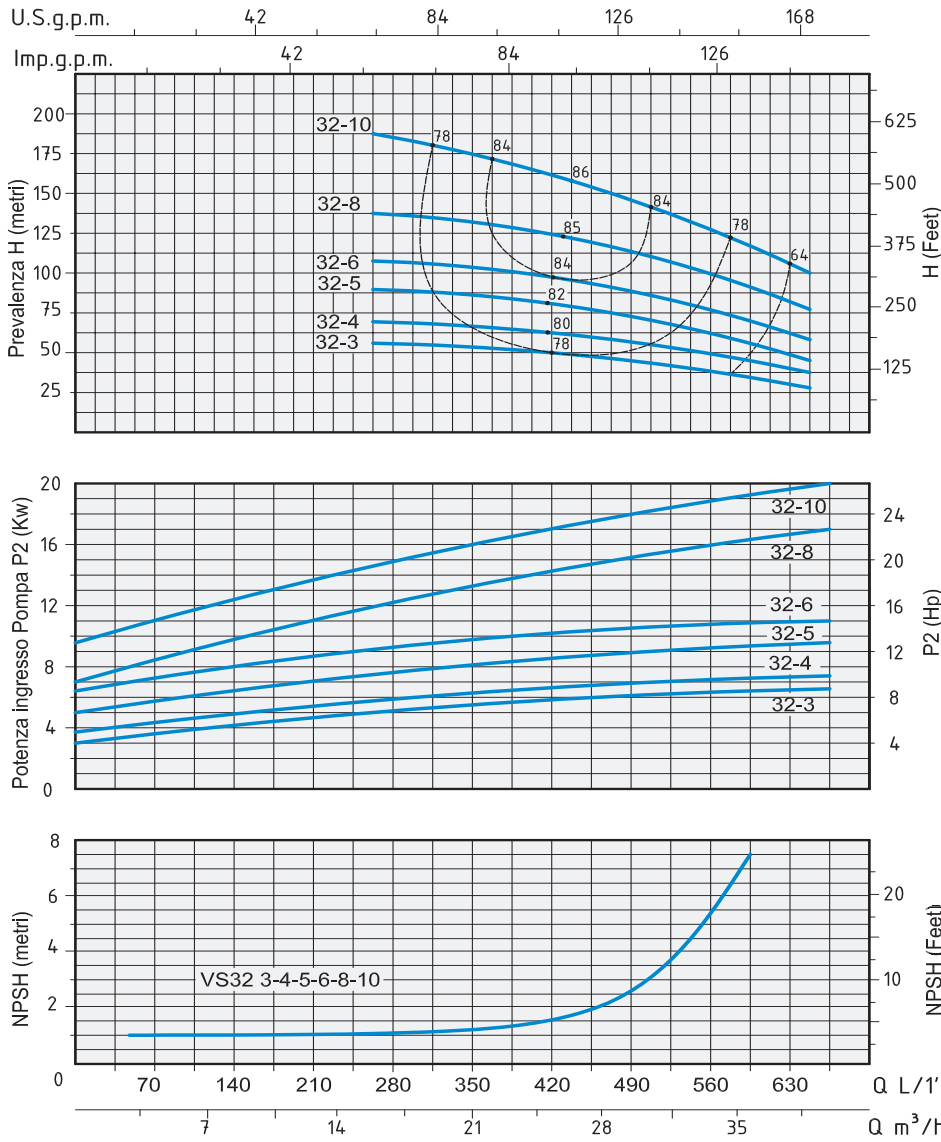

TIPO TYPE	DIMENSIONI mm - DIMENSIONS mm							FLANGIA FLANGE	DIMENSIONI DIMENSIONS mm			PESO WEIGHT Kg
	A	H	B1	B2	B1 + B2	D1	D2		P	L	H	
Trifase Three-phase												
VS 32-3	320	105	645	430	1075	260	208	DN 65 2" 1/2	417	1215	444	120,2
VS 32-4	320	105	715	430	1145	260	208	DN 65 2" 1/2	417	1215	444	130,8
VS 32-5	320	105	890	490	1380	330	255	DN 65 2" 1/2	515	1515	493	218,1
VS 32-6	320	105	960	490	1450	330	255	DN 65 2" 1/2	515	1515	493	222,1
VS 32-8	320	105	1100	490	1590	330	255	DN 65 2" 1/2	515	1715	490	241,5
VS 32-10	320	105	1240	550	1790	330	255	DN 65 2" 1/2	515	1915	495	264

APPLICAZIONI

Elettropompe universali per applicazioni civili ed industriali, per impianti di lavaggio ad alta pressione, per l'irrigazione, l'agricoltura, impianti sportivi, per fontane e per movimentazione di liquidi moderatamente aggressivi privi di sostanze solide o abrasive.

LIMITI D'IMPIEGO

- Temperatura liquido fino a 35°C (per un uso domestico secondo EN 60335-2-41)
- Temperatura max. liquido: 110°C (per altri impieghi)
- Temperatura ambiente fino a 40° C

MOTORE

- Trifase 400/690V-50Hz
- Motore elettrico ad induzione a 2 poli (n = 2900 min⁻¹)
- Isolamento Classe F
- Protezione IP 55

MATERIALI

- Corpo aspirazione Acciaio Inox AISI 304
- Corpo mandata Acciaio Inox AISI 304
- Girante Acciaio Inox AISI 304
- Camicia pompa Acciaio Inox AISI 304
- Coperchio superiore Acciaio Inox AISI 304
- Coperchio inferiore Acciaio Inox AISI 304
- Albero motore Acciaio Inox AISI 304
- Tenute meccaniche Silicio/Silicio/Viton

OPERATING CONDITIONS

- Liquid temperature up to 35°C (for home use according to EN 60335-2-41)
- Temperature max. liquid: 110°C (for other uses)
- Ambient temperature max to 40°C

MOTOR

- Three-phase 400/690V-50Hz
- Two-pole electric standard motor (n = 2900 min⁻¹)
- Insulation Class F
- Protection IP 55

MATERIALS

- Suction casing Stainless Steel AISI 304
- Delivery casing Stainless Steel AISI 304
- Impeller Stainless Steel AISI 304
- External jacket Stainless Steel AISI 304
- Upper cover Stainless Steel AISI 304
- Lower cover Stainless Steel AISI 304
- Pump shaft Stainless Steel AISI 304
- Mechanical seal Silicon/Silicon/Viton

APPLICATION

Universal pumps for domestic or municipal water supply systems, for clean non-explosive liquids without solid or abrasive substances, for agricultural irrigation and sports application, for civil and industrial use, boiler feeding and condensate systems and for high pressure washing plants.



TIPO TYPE	POTENZA NOMINALE NOMINAL POWER		AMPERE	Q = PORTATA - CAPACITY										
	HP	kW		m ³ /h	30	32	36	42	45	50	55	65	70	80
Trifase Three-phase	P2		Trifase Three-phase	lt/1'	500	573	600	700	750	832	916	1083	1166	1333
	Prevalenza manometrica totale in m.C.A. - Total head in meters w.c.													
VS 65-1	7,5	5,5	10,7	H (m)	27	25,5	24,5	23,5	23	22	21,5	19,5	18,5	15
VS 65-2	15	11	19,4		53	51	50	48	47	46	45	41	39	30
VS 65-3	25	18,5	27,5		80	77	75	73	72	70	67	62	58	46
VS 65-4	30	22	37		107	103	101	98	96	93	90	83	79	61
VS 65-5	40	30	48,5		136	133	131	127	125	121	117	107	103	78

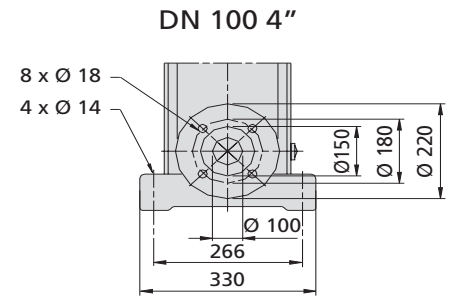
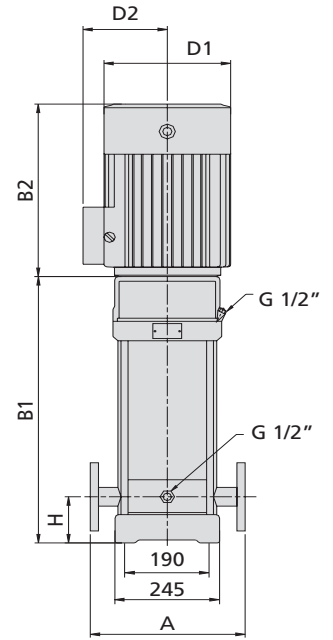
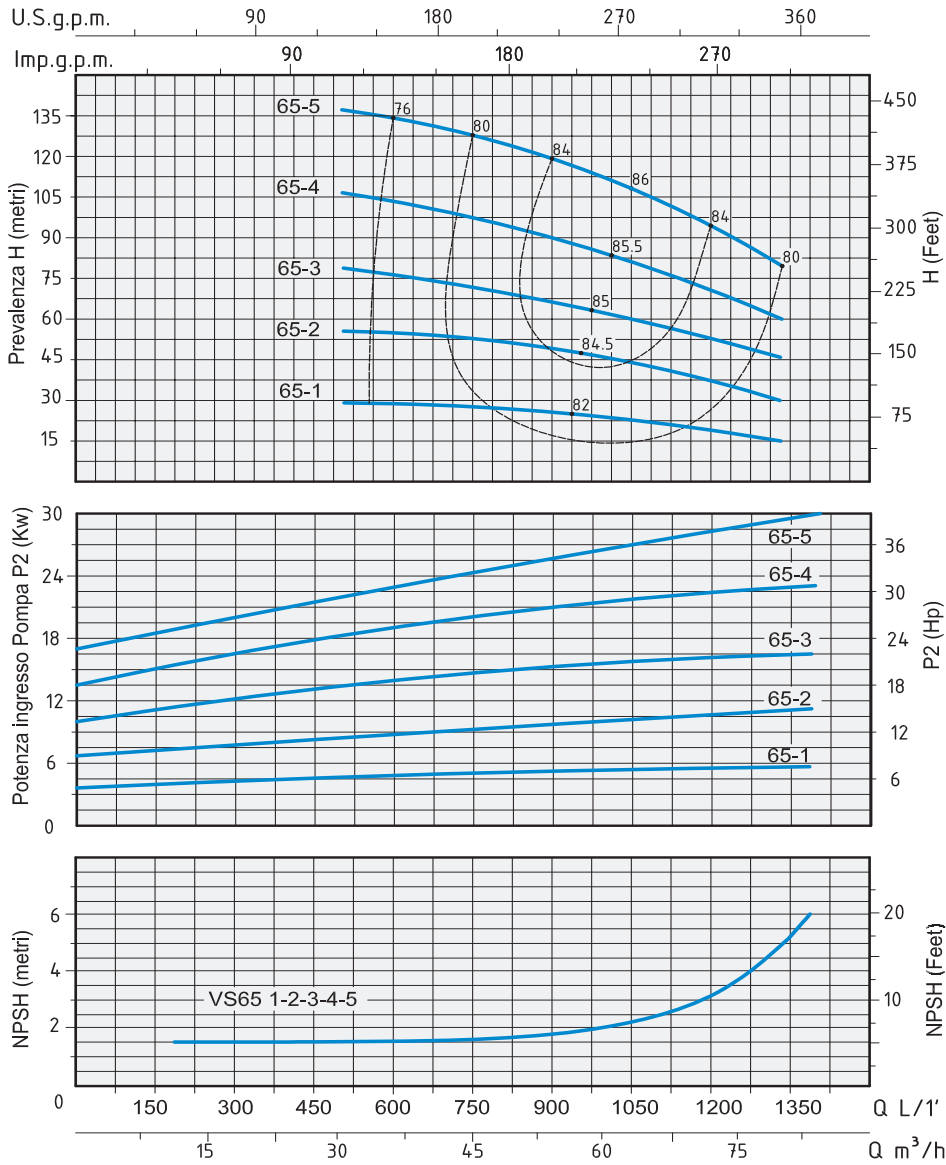

TIPO TYPE	DIMENSIONI mm - DIMENSIONS mm							FLANGIA FLANGE	DIMENSIONI DIMENSIONS mm			PESO WEIGHT Kg
	A	H	B1	B2	B1 + B2	D1	D2		P	L	H	
Trifase Three-phase												
VS 65-1	365	140	561	430	991	260	208	DN 100 4"	417	1215	445	128,7
VS 65-2	365	140	754	490	1244	330	255	DN 100 4"	515	1515	493	182
VS 65-3	365	140	836	550	1386	330	255	DN 100 4"	515	1515	493	248
VS 65-4	365	140	919	590	1509	360	285	DN 100 4"	515	1515	493	285
VS 65-5	365	140	1001	660	1661	400	310	DN 100 4"	515	1715	490	345

APPLICAZIONI

Elettropompe universali per applicazioni civili ed industriali, per impianti di lavaggio ad alta pressione, per l'irrigazione, l'agricoltura, impianti sportivi, per fontane e per movimentazione di liquidi moderatamente aggressivi privi di sostanze solide o abrasive.

LIMITI D'IMPIEGO

- Temperatura liquido fino a 35°C (per un uso domestico secondo EN 60335-2-41)
- Temperatura max. liquido: 110°C (per altri impieghi)
- Temperatura ambiente fino a 40° C

MOTORE

- Trifase 400/690V-50Hz
- Motore elettrico ad induzione a 2 poli (n = 2900 min⁻¹)
- Isolamento Classe F
- Protezione IP 55

MATERIALI

- Corpo aspirazione Acciaio Inox AISI 304
- Corpo mandata Acciaio Inox AISI 304
- Girante Acciaio Inox AISI 304
- Camicia pompa Acciaio Inox AISI 304
- Coperchio superiore Acciaio Inox AISI 304
- Coperchio inferiore Acciaio Inox AISI 304
- Albero motore Acciaio Inox AISI 304
- Tenute meccaniche Silicio/Silicio/Viton

OPERATING CONDITIONS

- Liquid temperature up to 35°C (for home use according to EN 60335-2-41)
- Temperature max. liquid: 110°C (for other uses)
- Ambient temperature max to 40°C

MOTOR

- Three-phase 400/690V-50Hz
- Two-pole electric standard motor (n = 2900 min⁻¹)
- Insulation Class F
- Protection IP 55

MATERIALS

- Suction casing Stainless Steel AISI 304
- Delivery casing Stainless Steel AISI 304
- Impeller Stainless Steel AISI 304
- External jacket Stainless Steel AISI 304
- Upper cover Stainless Steel AISI 304
- Lower cover Stainless Steel AISI 304
- Pump shaft Stainless Steel AISI 304
- Mechanical seal Silicon/Silicon/Viton

APPLICATION

Universal pumps for domestic or municipal water supply systems, for clean non-explosive liquids without solid or abrasive substances, for agricultural irrigation and sports application, for civil and industrial use, boiler feeding and condensate systems and for high pressure washing plants.



TIPO TYPE	POTENZA NOMINALE NOMINAL POWER		AMPERE	Q = PORTATA - CAPACITY								
	HP	kW		Trifase Three-phase	m ³ /h	50	60	70	80	85	90	100
Trifase Three-phase	P2		Trifase Three-phase	lt/1'	833	1000	1166	1333	1416	1500	1666	1833
	Prevalenza manometrica totale in m.C.A. - Total head in meters w.c.											
VS 85-1	10	7,5	14,5	H (m)	25	24	22	21	20	19	16	12
VS 85-2	20	15	27		53	50	47	44	41	40	36	30
VS 85-3	30	22	37		81	77	72	67	64	62	55	48
VS 85-4	40	30	51		110	105	100	92	86	84	76	66
VS 85-5	50	37	65		139	131	124	115	110	106	94	83

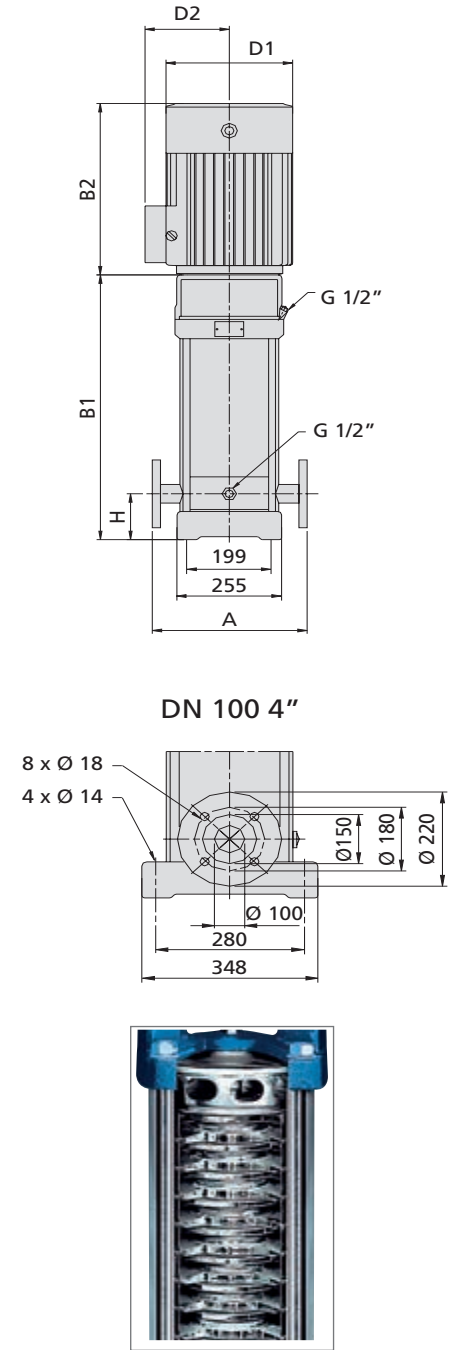
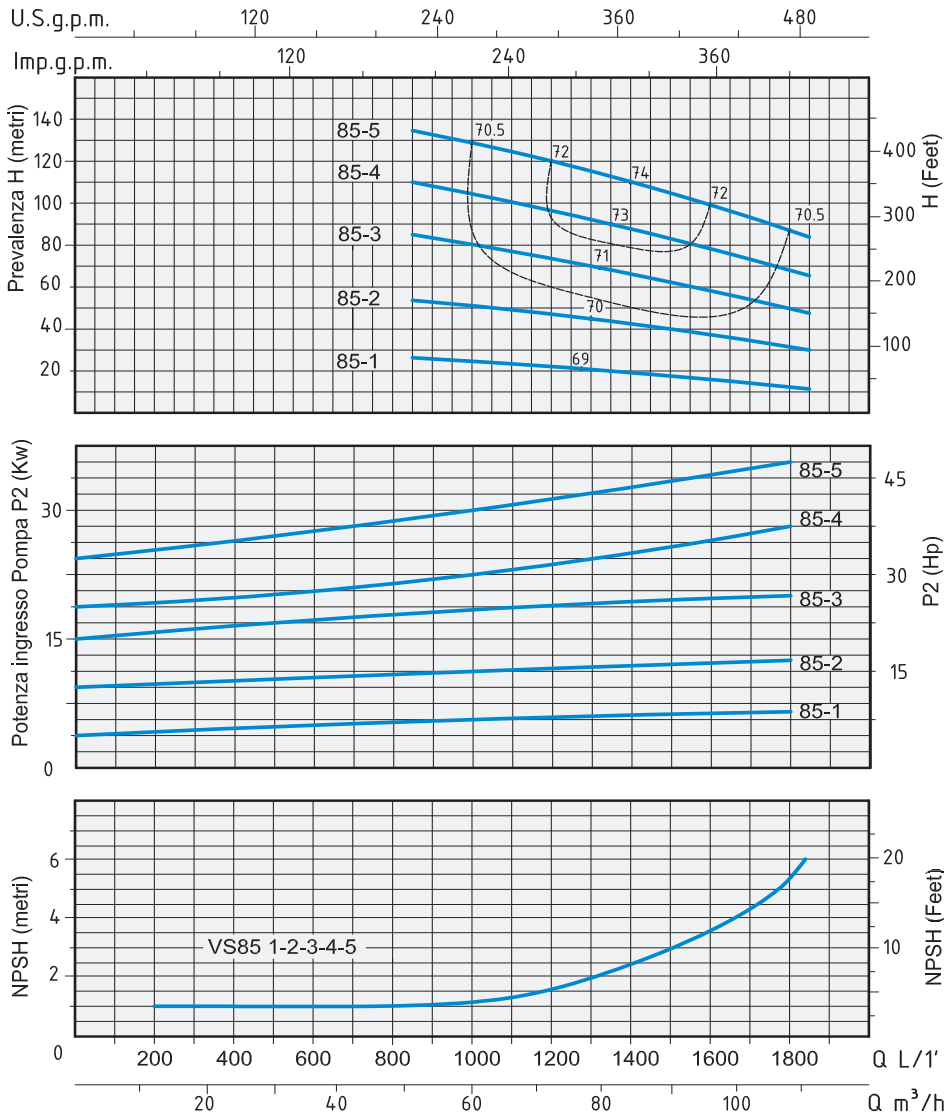

TIPO TYPE	DIMENSIONI mm - DIMENSIONS mm								DIMENSIONI DIMENSIONS mm			PESO WEIGHT Kg
	A	H	B1	B2	B1 + B2	D1	D2	FLANGIA FLANGE	P	L	H	
Trifase Three-phase												
VS 85-1	380	140	571	390	961	260	208	DN 100 4"	417	1215	445	110
VS 85-2	380	140	773	500	1273	330	255	DN 100 4"	515	1515	493	192
VS 85-3	380	140	865	575	1440	360	285	DN 100 4"	515	1515	493	252
VS 85-4	380	140	957	650	1607	400	310	DN 100 4"	515	1715	490	312
VS 85-5	380	140	1049	650	1699	400	310	DN 100 4"	515	1715	490	336