

## 1994

The first Hitek inverter was R&D and manufactured in China . Hitek frequency inverte won the invention award in same year. Hitek Electric was founded.



## 2013

Hitek Electric combine Hitek inverter , Hitek servo and B&B power units to form a joint venture, New Hitek Electric Group

 [www.famcocorp.com](http://www.famcocorp.com)

 E-mail: [info@famcocorp.com](mailto:info@famcocorp.com)

 [@famco\\_group](https://www.instagram.com/famco_group)

 Tel: ۰۲۱-۴۸۰۰۰۰۴۹

 Fax : ۰۲۱ - ۴۴۹۹۴۶۴۲

تهران ، کیلومتر ۲۱ بزرگراه لشگری (جاده مخصوص کرج)

روبروی پالایشگاه نفت پارس ، پلاک ۱۲

# About Us



Hitek Electric Co., Ltd., referred to as Hitek Electric, was founded in 1994. It is located in Wenling. The on inverter manufacturing, and its market share has always been in the fore front of the industry. It is one professional inverter manufacturers in Taiwan that integrates R & D, production and sales.

The company has 270 patented technologies and 21 software copyrights; the total construction area of its own workshop is 35,000 square meters. Three major R & D centers have been established in Germany. The sales network and after-sales service agencies have been distributed in major provinces, cities and autonomous regions in the country, and are exported to Europe, America, Southeast Asia, the Middle East and other countries. After nearly 20 years of leaping development, it has been rated as the "Top Ten Domestic Low-Voltage Frequency Converter Brands for many consecutive years.

Hitek Electric always adheres to the service concept of quality first, customer first, relying on the advantages of technology research and development and marketing channels, actively broadening the product line, continuously improving the core competitiveness of products in the market, and providing power, new energy, machinery manufacturing and other industries. High-quality electrical products and personalized solutions.

Drive whatever you want to create a better future!

**Hitek Electric Co., Ltd**

## Professional inverter

manufacturing

 [www.famcocorp.com](http://www.famcocorp.com)

 E-mail: [info@famcocorp.com](mailto:info@famcocorp.com)

 [@famco\\_group](https://www.instagram.com/famco_group)

## Electrical transmission

research

 Tel: ۰۲۱-۴۸۰۰۰۰۴۹

 Fax : ۰۲۱ - ۴۴۹۹۴۶۴۲

## Gross floor area

۳۵۰۰۰م<sup>۲</sup>

تهران، کیلومتر ۲۱ بزرگراه لشگری (جاده مخصوص کرج)

روبروی پالایشگاه نفت پارس، پلاک ۱۲



## Wenling production Center

Covers an area of 35,000 square meters and integrated plant with completely own property rights, Including production, research and development, technology, finance, administration, personnel, procurement, warehousing and others.



[www.famcocorp.com](http://www.famcocorp.com)

E-mail: [info@famcocorp.com](mailto:info@famcocorp.com)

[@famco\\_group](https://www.instagram.com/famco_group)

Tel: ۰۲۱-۴۸۰۰۰۰۴۹

Fax: ۰۲۱-۴۴۹۹۴۶۴۲

تهران، کیلومتر ۲۱ بزرگراه لشگری (جاده مخصوص کرج)

روبروی پالایشگاه نفت پارس، پلاک ۱۲

# Domestic center

**FAMCO**  
هایپر صنعت



 [www.famcocorp.com](http://www.famcocorp.com)

 E-mail: [info@famcocorp.com](mailto:info@famcocorp.com)

 [@famco\\_group](https://www.instagram.com/famco_group)

 Tel: ۰۲۱-۴۸۰۰۰۰۴۹

 Fax: ۰۲۱-۴۴۹۹۴۶۴۲

تهران، کیلومتر ۲۱ بزرگراه لشگری (جاده مخصوص کرج)

روبروی پالایشگاه نفت پارس، پلاک ۱۲

# Company history

**FAMCO**  
هایپر صنعت

2000

"Taizhou Fuling Motor Co., Ltd" officially founded

2010

Renamed as "Taizhou Fuling Electrical Co., Ltd" and registered capital increased to 5,000,000 USD

2014

Elected as famous brand of Zhejiang  
Company name was renamed to Zhejiang New Follin Electric Co., Ltd

2016

Honored as famous brand product of Zhejiang

2001

ISO9001:2000 APPROVED/  
CE approved

2007

Elected as one of the first council members of CEEIA Inverter Department. Posted on inverter industry authority magazine "Inverter World". Honored as one of the "China Top 10 Brands". Chosen as the "Member of the Year 2007" by CEEIA

2009

Became "the best Commercial Partner" of Infineon

2004

Honored as one of the "Zhejiang Hi-Tech Enterprises"

1994

In Wenling, the city with the first Chinese private enterprise founded, Fuling started its first step

2012

Newly increases 2 more brands: "FUREEN" and "B&B Power"

2011

Elected as one of the second council members of CEEIA Inverter Department

DZB10HV series inverter has been approved as the "Zhejiang Technology Innovation Special Item"

2013

Honored as famous brand product of Zhejiang

2015

SGS approved

2019

Sinopec Yipai certification  
18000 approved

More than 300,000 square meters

[www.famcocorp.com](http://www.famcocorp.com)

E-mail: [info@famcocorp.com](mailto:info@famcocorp.com)

@famco\_group

Tel: ۰۲۱-۴۸۰۰۰۰۴۹

Fax: ۰۲۱-۴۴۹۹۴۶۴۲

تهران، کیلومتر ۲۱ بزرگراه لشگری (جاده مخصوص کرج)

روبروی پالایشگاه نفت پارس، پلاک ۱۲

# Company history

## Business description

- A leading global provider of high performance for industrial, professional drive products for automatic industrial and consumer users
  - for mechanics and for the construction trades
  - accessories for industrial customers used in assembly, maintenance and R&D environments
- Headquartered in Zhejiang, China, with ~500 employees
- Large and diverse end-markets including automotive, aerospace, mining, energy, rail and general industry
- manufacturing facilities in the Zhejiang, China, with best cost and efficient supply chain profiles
- Highly recognized and proprietary industrial and professional brands, sold direct and through distribution



## 2018A Net sales breakdown

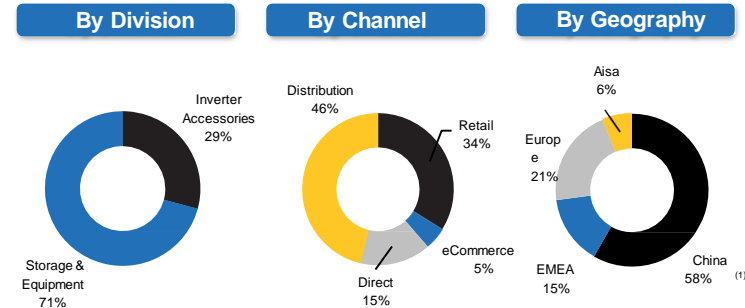

## Summary financials

(\$ in millions)

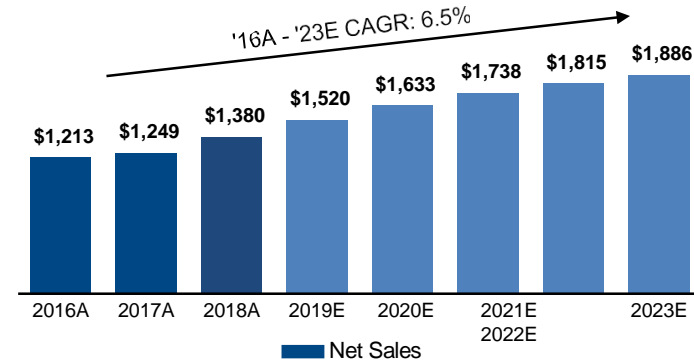

# Global service system

11

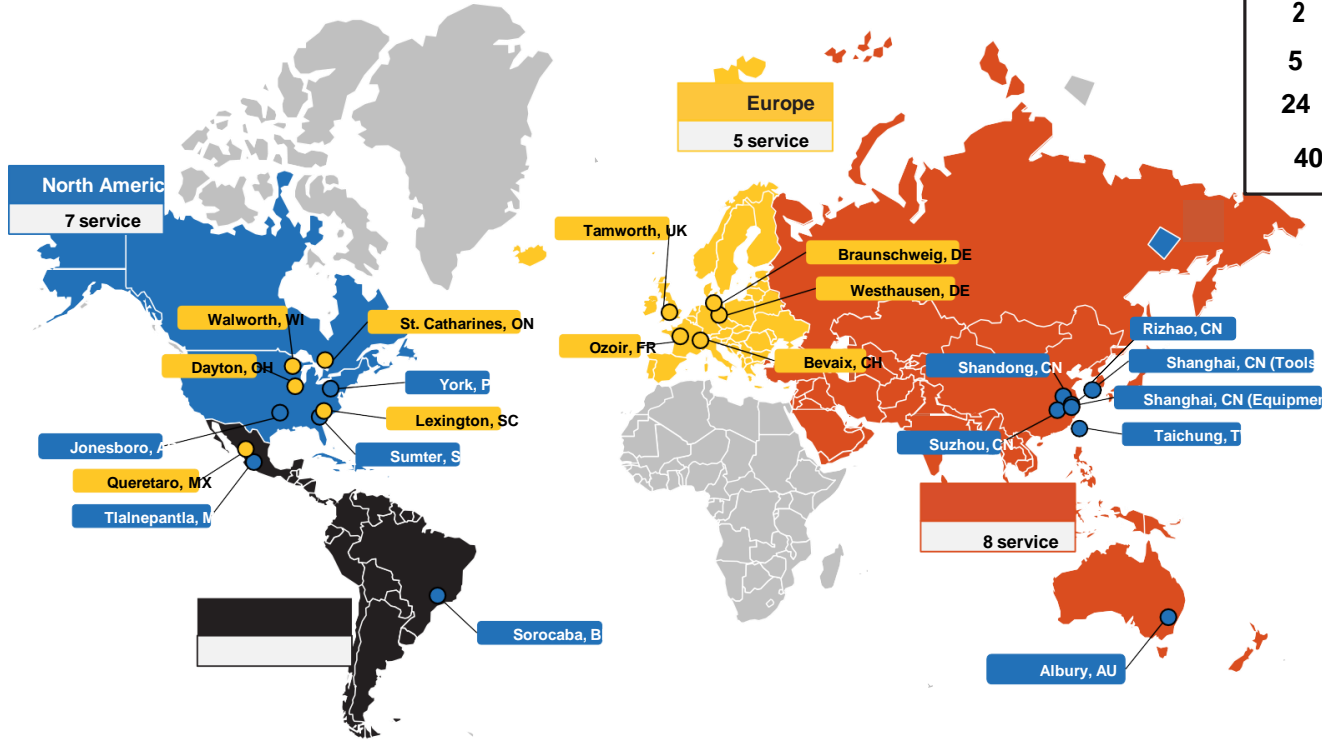

- 1 Dc Centers in Taiwan.
- 2 Business center
- 5 Global storage center
- 24 All hours for service
- 40+ Global service center

# Our Core Values

## CUSTOMERS COME FIRST



Our first priority is exceeding customer expectations for quality, delivery, value, and innovation.

## INTEGRITY IN ALL WE DO



Building strong relationships with co-workers, customers, and communities.

## CONTINUOUS IMPROV



Implement and sustain safe, lean processes to drive out waste and improve productivity.

## INNOVATION FOR GROWTH



Creative ideas

## BEST TALENT – ONE TEAM



High performing,



# R&D core team

**FAMCO**  
هایپر صنعت



**Global R&D team**



[www.famcocorp.com](http://www.famcocorp.com)

E-mail: [info@famcocorp.com](mailto:info@famcocorp.com)

@famco\_group

Tel: +۹۰۲۱-۴۸۰۰۰۰۴۹

Fax: +۹۰۲۱-۴۴۹۹۴۶۴۲

تهران، کیلومتر ۲۱ بزرگراه لشگری (جاده مخصوص کرج)

روبروی پالایشگاه نفت پارس، پلاک ۱۲

# Our certificate

**FAMCO**  
هایپر صنعت



www.famcocorp.com  
E-mail: info@famcocorp.com  
@famco\_group

Tel: ۰۲۱-۴۸۰۰۰۰۴۹  
Fax: ۰۲۱-۴۴۹۹۴۶۴۲

تهران، کیلومتر ۲۱ بزرگراه لشگری (جاده مخصوص کرج)  
روبروی پالایشگاه نفت پارس، پلاک ۱۲

# Production workshop

**FAMCO**  
هایپر صنعت



**Intelligent  
production  
workshop**



[www.famcocorp.com](http://www.famcocorp.com)

E-mail: [info@famcocorp.com](mailto:info@famcocorp.com)

@famco\_group

Tel: ۰۲۱- ۴ ۸ ۰ ۰ ۰ ۰ ۴ ۹

Fax : ۰۲۱ - ۴۴۹۹۴۶۴۲

تهران، کیلومتر ۲۱ بزرگراه لشگری (جاده مخصوص کرج)

روبروی پالایشگاه نفت پارس، پلاک ۱۲



**24/7 technical service team  
give the technical support immediately**

[www.famcocorp.com](http://www.famcocorp.com)

E-mail: [info@famcocorp.com](mailto:info@famcocorp.com)

@famco\_group

Tel: ۰۲۱-۴۸۰۰۰۰۴۹

Fax: ۰۲۱-۴۴۹۹۴۶۴۲

تهران، کیلومتر ۲۱ بزرگراه لشگری (جاده مخصوص کرج)

روبروی پالایشگاه نفت پارس، پلاک ۱۲

# Shipment system





Sufficient safety stocks to form a comprehensive three-dimensional transportation network of land, sea and airplane.

 [www.famcocorp.com](http://www.famcocorp.com)

 E-mail: [info@famcocorp.com](mailto:info@famcocorp.com)

 [@famco\\_group](https://www.instagram.com/famco_group)

 Tel: ۰۲۱-۴۸۰۰۰۰۴۹

 Fax: ۰۲۱-۴۴۹۹۴۶۴۲

تهران، کیلومتر ۲۱ بزرگراه لشگری (جاده مخصوص کرج)

روبروی پالایشگاه نفت پارس، پلاک ۱۲



## High Technology Your Best Choice

[www.famcocorp.com](http://www.famcocorp.com)  
E-mail: [info@famcocorp.com](mailto:info@famcocorp.com)  
[@famco\\_group](https://www.instagram.com/famco_group)

Tel: ۰۲۱-۴۸۰۰۰۰۴۹  
Fax: ۰۲۱-۴۴۹۹۴۶۴۲

تهران، کیلومتر ۲۱ بزرگراه لشگری (جاده مخصوص کرج)  
روبروی پالایشگاه نفت پارس، پلاک ۱۲

# Domestic exhibition

**FAMCO**  
هایپر صنعت

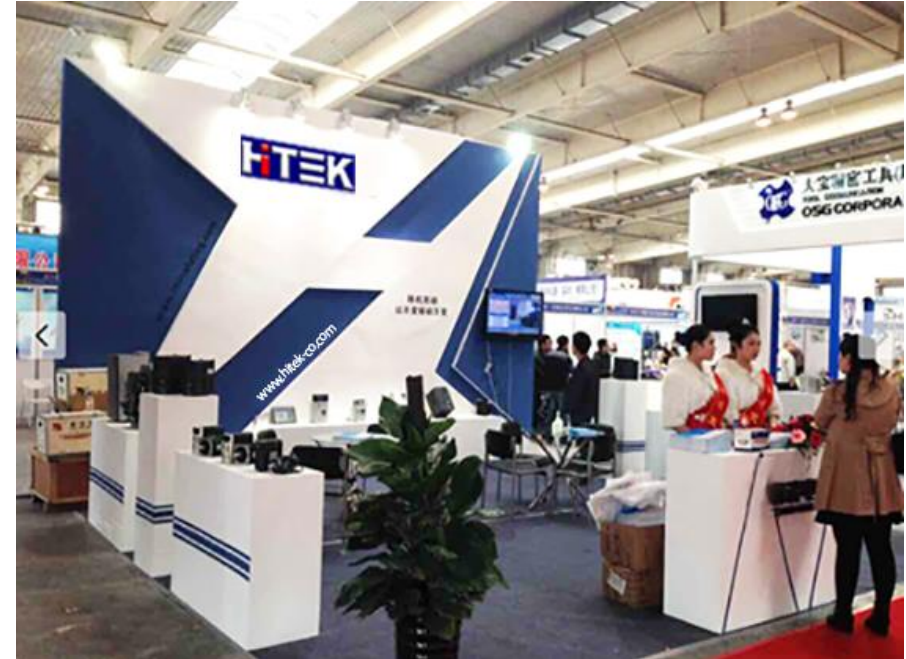

**High Technology**  
**Your Best Choice**

[www.famcocorp.com](http://www.famcocorp.com)  
E-mail: [info@famcocorp.com](mailto:info@famcocorp.com)  
[@famco\\_group](https://www.instagram.com/famco_group)

Tel: ۰۲۱-۴۸۰۰۰۰۴۹  
Fax: ۰۲۱-۴۴۹۹۴۶۴۲

تهران، کیلومتر ۲۱ بزرگراه لشگری (جاده مخصوص کرج)  
روبروی پالایشگاه نفت پارس، پلاک ۱۲

# Servo exhibition

**FAMCO**  
هایپر صنعت



**High Technology**  
**Your Best Choice**

[www.famcocorp.com](http://www.famcocorp.com)

E-mail: [info@famcocorp.com](mailto:info@famcocorp.com)

@famco\_group

Tel: ۰۲۱-۴۸۰۰۰۰۴۹

Fax: ۰۲۱-۴۴۹۹۴۶۴۲



تهران، کیلومتر ۲۱ بزرگراه لشگری (جاده مخصوص کرج)

روبروی پالایشگاه نفت پارس، پلاک ۱۲



# Products and production capacity

**FAMCO**  
هایپر صنعت

## Main products :

- 380V low voltage universal inverter
- 3KV Medium Voltage Inverter
- 6KV high voltage inverter
- 10KV high voltage inverter



## Company production capacity :

### 1. Monthly output:

more than 12,000 low-voltage inverters 220V/380V/690V:  
( 0.75KW-1000KW )

### 2. Annual output:

more than 300 high-voltage inverters  
( 3KV/6KV/10KV: 280KW-16000KW )



 www.famcocorp.com

 E-mail: info@famcocorp.com

 @famco\_group

 Tel: ۰۲۱-۴۸۰۰۰۰۴۹

 Fax: ۰۲۱-۴۴۹۹۴۶۴۲

تهران، کیلومتر ۲۱ بزرگراه لشگری (جاده مخصوص کرج)

روبروی پالایشگاه نفت پارس، پلاک ۱۲

## Part 02

### Hitek Low-Voltage Inverter

The user can demonstrate on a projector or computer, or presentation and make it film to be used in a wider field

[www.famcocorp.com](http://www.famcocorp.com)

E-mail: [info@famcocorp.com](mailto:info@famcocorp.com)

@famco\_group

Tel: ۰۲۱-۴۸۰۰۰۰۴۹

Fax: ۰۲۱-۴۴۹۹۴۶۴۲

تهران، کیلومتر ۲۱ بزرگراه لشگری (جاده مخصوص کرج)

روبروی پالایشگاه نفت پارس، پلاک ۱۲

## F300 series



**Rated power :**  
0.75Kw to 1000Kw

[www.famcocorp.com](http://www.famcocorp.com)

E-mail: [info@famcocorp.com](mailto:info@famcocorp.com)

@famco\_group

## F200 series



**Rated power :**  
5.5Kw to 132Kw

Tel: ۰۲۱-۴۸۰۰۰۰۴۹

Fax: ۰۲۱-۴۴۹۹۴۶۴۲

## F100 series



**Rated power :**  
0.75Kw to 37Kw

تهران، کیلومتر ۲۱ بزرگراه لشگری (جاده مخصوص کرج)

روبروی پالایشگاه نفت پارس، پلاک ۱۲

## F300 series



Form 4 VFD 200V/280V/600V/1100V

[www.famcocorp.com](http://www.famcocorp.com)

E-mail: [info@famcocorp.com](mailto:info@famcocorp.com)

@famco\_group

Tel: ۰۲۱-۴۸۰۰۰۰۴۹

Fax: ۰۲۱-۴۴۹۹۴۶۴۲

تهران، کیلومتر ۲۱ بزرگراه لشگری (جاده مخصوص کرج)

روبروی پالایشگاه نفت پارس، پلاک ۱۲

# F300 series VFD

Models	Rated power (kW)	Rated input current (A)	Rated output current (A)	Adaptive motor (KW)
Input 1PH 220V±15% 47Hz~63Hz				
F300-0R4G-2	0.55	5.4	4.0	0.55
F300-0R7G-2	0.75	8.2	5.0	0.75
F300-1R5G-2	1.5	14.0	7.0	1.5
F300-2R2G-2	2.2	23	10.0	2.2

Models	Rated power (kW)	Rated input current (A)	Rated output current (A)	Adaptive motor (KW)
Input 3PH 220V±15% 47Hz~63Hz				
F300-0R5G-2	0.55	3.8	3.2	0.55
F300-0R7G-2	0.75	4.9	4.1	0.75
F300-1R5G-2	1.5	8.4	7.0	1.5
F300-2R2G-2	2.2	11.5	10.0	2.2
F300-3R7G-2	3.7	18	15	3.7
F300-5R5G-2	5.5	24	23	5.5
F300-7R5G-2	7.5	37	31	7.5
F300-011G-2	11	52	45	11
F300-015G-2	15	68	58	15
F300-018G-2	18	84	71	18
F300-022G-2	22	94	85	22
F300-030G-2	30	120	115	30
F300-037G-2	37	160	145	37

Models	Rated power (kW)	Rated input current (A)	Rated output current (A)	Adaptive motor (KW)
Input 3PH 380V±15% 47Hz~63Hz				
F300-0R7G/1R5P-4	0.75/1.5	3.4/5.0	2.8/3.7	0.75/1.5
F300-1R5G/2R2P-4	1.5/2.2	5.0/5.8	3.7/5.0	1.5/2.2
F300-2R2G/3R7P-4	2.2/3.7	5.8/10.5	5.0/8.5	2.2/3.7
F300-3R7G/5R5P-4	3.7/5.5	10.5/14.6	8.5/13	3.7/5.5
F300-5R5G/7R5P-4	5.5/7.5	14.6/20.5	13/18	5.5/7.5
F300-7R5G/011P-4	7.5/11	20.5/26	18/24	7.5/11
F300-011G/015P-4	11/15	26/35	24/30	11/15
F300-015G/018P-4	15/18.5	35/38.5	30/37	15/18.5
F300-018G/022P-4	18.5/22	38.5/46.5	37/46	18.5/22
F300-022G/030P-4	22/30	46.5/62	46/58	22/30
F300-030G/037P-4	30/37	62/76	58/75	30/37
F300-037G/045P-4	37/45	76/92	75/90	37/45
F300-045G/055P-4	45/55	92/113	90/110	45/55
F300-055G/075P-4	55/75	113/157	110/150	55/75
F300-075G/093P-4	75/93	157/180	150/170	75/93
F300-093G/110P-4	93/110	180/214	170/210	93/110
F300-110G/132P-4	110/132	214/256	210/250	110/132
F300-132G/160P-4	132/160	256/307	250/300	132/160
F300-160G/200P-4	160/200	307/385	300/380	160/200
F300-200G/220P-4	200/220	385/430	380/430	200/220
F300-220G/250P-4	220/250	430/468	430/465	220/250
F300-250G/280P-4	250/280	468/525	465/520	250/280
F300-280G/315P-4	280/315	525/590	520/585	280/315
F300-315G/350P-4	315/350	590/665	585/650	315/350

www.famcocorp.com

E-mail: info@famcocorp.com

@famco\_group

Tel: ۰۲۱-۴۸۰۰۰۰۴۹

Fax: ۰۲۱-۴۴۹۹۴۶۴۲

تهران، کیلومتر ۲۱ بزرگراه لشگری (جاده مخصوص کرج)

روبروی پالایشگاه نفت پارس، پلاک ۱۲

# F300 series VFD

- AC drive nameplate:

<b>MODEL: F300-3R7G/5R5P-4</b>	Specification and model
<b>INPUT: 3PH 380V 50/60Hz</b>	Input
<b>OUTPUT: 3PH 0~380V 0~600Hz</b>	Output
<b>POWER: 3.7/5.5KW 8.5/13A</b>	Power
<b>S / N:</b> 	Bar code
<b>01B3413A115251001</b>	Serial number

- Specifications and models:

**F300 - 3R7G/5R5P - 4 - XX**

Technology version

Input voltage classes:

2:220V 4:380V

6:660V 7:1140V

Specifications and models:

Heavy load 3.7kW

Light load 5.5kW

Serial code: **F300 Series**

- Production code:

**06 10 8888**

Productive serial number

[www.famcocorp.com](http://www.famcocorp.com)

E-mail: [info@famcocorp.com](mailto:info@famcocorp.com)

@famco\_group

Tel: ۰۲۱-۴۸۰۰۰۰۴۹

Fax: ۰۲۱-۴۴۹۹۴۶۴۲



تهران، کیلومتر ۲۱ بزرگراه لشگری (جاده مخصوص کرج)

روبروی پالایشگاه نفت پارس، پلاک ۱۲

# F300 series VFD

**FAMCO**  
هایپر صنعت

## F300 Series High Performance Vector AC vector

F300 is the latest generation of high performance vector control inverter developed by I

Multiple control modes and new speed sensor less vector control (SVC) algorithm can achieves stability at slow speed. Stronger load capacity at low frequency support SVC torque control and multiple.

PG cards it can realize close loop control of asynchronous motor.

Stronger functions , functional of motor control has clearly raised.

Applications :

- CNC machine tools
- packaging machinery
- wire drawing machines
- elevator door machines
- fan and pump
- dehydration machine
- centrifuge machine
- injection molding machine
- paper making machinery
- lifting machinery
- hoist



www.famcocorp.com

E-mail: info@famcocorp.com

@famco\_group

Tel: ۰۲۱-۴۸۰۰۰۰۴۹

Fax: ۰۲۱-۴۴۹۹۴۶۴۲

تهران، کیلومتر ۲۱ بزرگراه لشگری (جاده مخصوص کرج)

روبروی پالایشگاه نفت پارس، پلاک ۱۲

# F300 series VFD

## Basic wiring diagram

- ⊙ Main circuit terminal
- Control circuit terminal

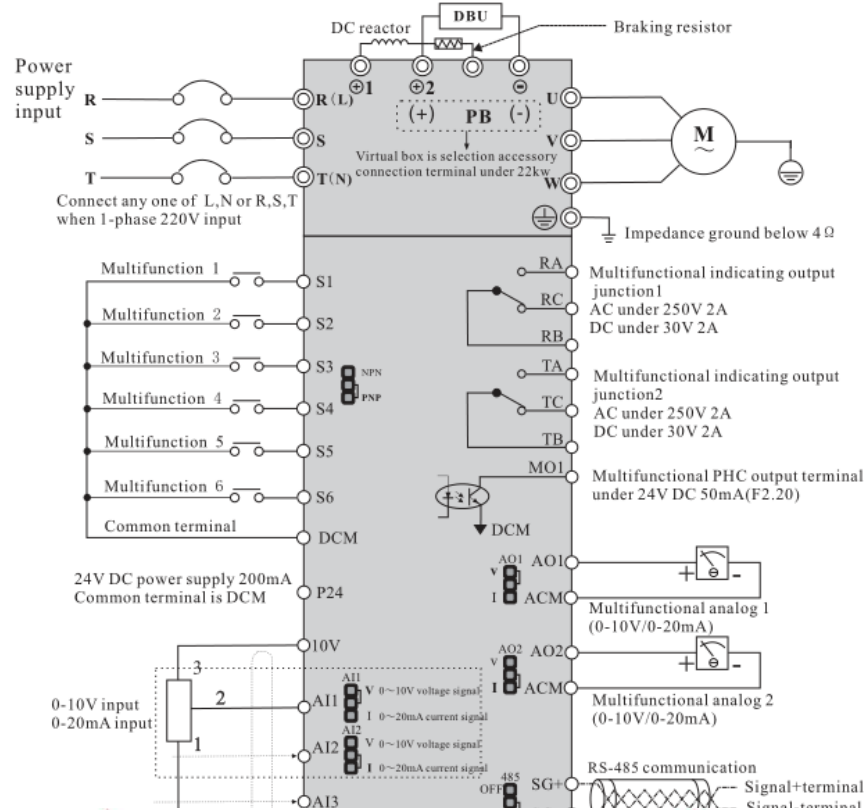



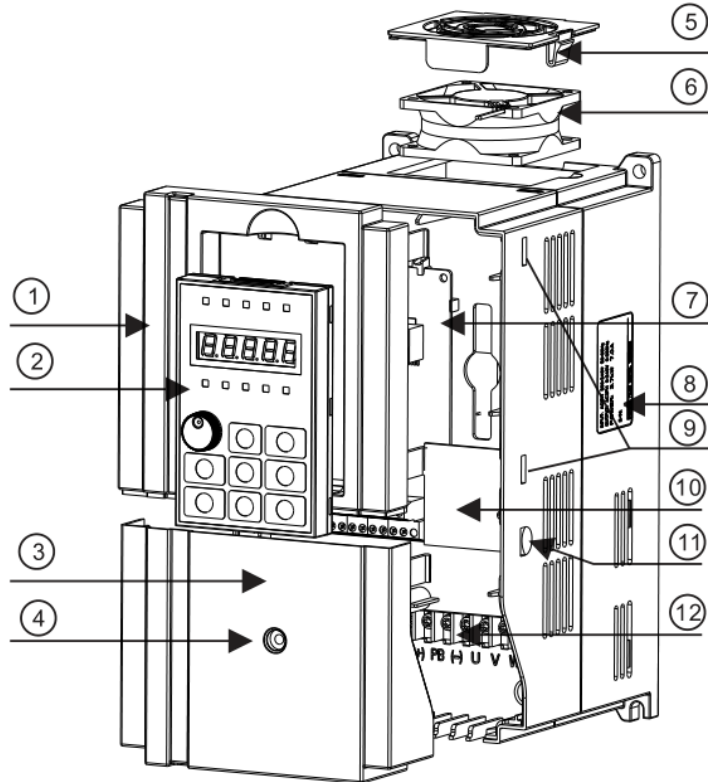

No.	Name	Description
①	Pre-cover	Used for install display keyboard and protect components
②	Keyboard	Used for amend and check inverter parameters, operation and other functions
③	Tail-hood	
④	Retaining screw of tail-hood	Used to fix tail-hood, and loosen this screw first while disassembly
⑤	Snap joint of fan	Used to fix fan, convenient to disassembly
⑥	Cooling fan	Internal heat dissipation of inverter
⑦	Control board	CPU board of inverter
⑧	Nameplate	
⑨	Snap joint of pre-cover	Used to fix pre-cover, total four on both left and right
⑩	Expansion board	Built-in multifunctional expansion board
⑪	Snap joint of tail-hood	Used to fix tail-hood, one on both left and right
⑫	Main loop terminal	

## Outstanding performance

- 1) Large torque output when low frequency ;
- 2) Fast dynamic response ;
- 3) Super strong overload capacity

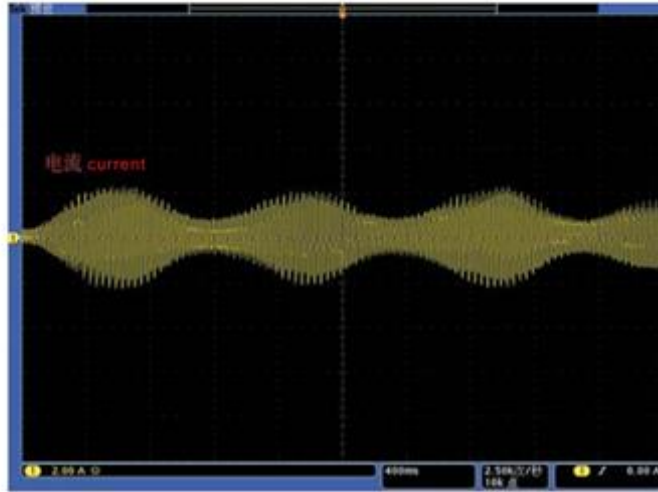

0.5Hz full-load output

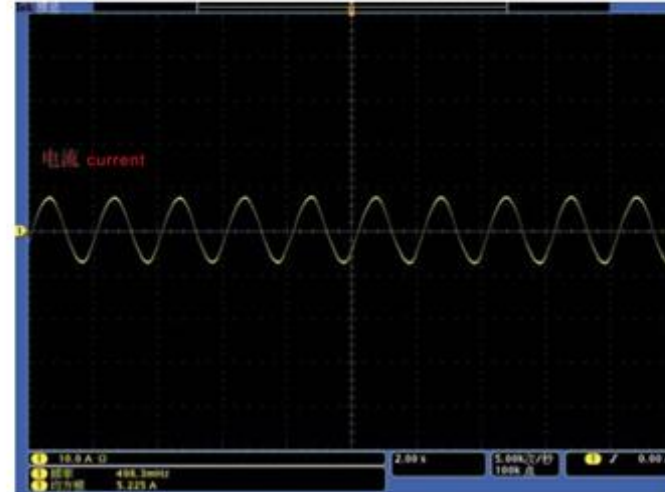

50Hz sudden load

## Accurate motor parameter self learning

F300 series inverter can accurately provide dynamic or static self-learning of motor parameters, simple

### Dynamic self-learning

It need release the load,

### Static self-learning

Applicable to the motor and load

www.famcocorp.com

E-mail: info@famcocorp.com

@famco\_group

Tel: ۰۲۱-۴۸۰۰۰۰۴۹

Fax: ۰۲۱-۴۴۹۹۴۶۴۲

تهران، کیلومتر ۲۱ بزرگراه لشگری (جاده مخصوص کرج)

روبروی پالایشگاه نفت پارس، پلاک ۱۲

## ▶ Support multiple control mode

Speed sensorless vector control (SVC), sensor vector control (VC), V/F control



Differential Encoder



Resolver

## ▶ Flexible and practical analog input/output

Each analog input (AI1 ~ AI3) can set 4 point curves.

## ▶ High-speed pulse input and output functions

High speed pulse signal specification: voltage range 9V~26V, frequency range 0 ~ 100 KHZ. Can setting 2 pint curves, high control precision. HDI/HDO high speed pulse input/output terminal can be used for DI/DO.

## ▶ Frequency source binding & compose

Run command source are free to bind an source. 10 kinds of main-auxiliary frequency source, flexible to adjust and compose.

For example : A+B、A-B、AB switch, etc

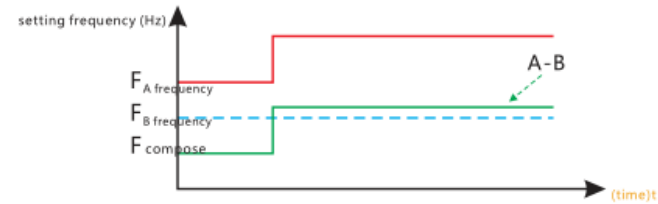

## ▶ None-stop when instantaneous power off

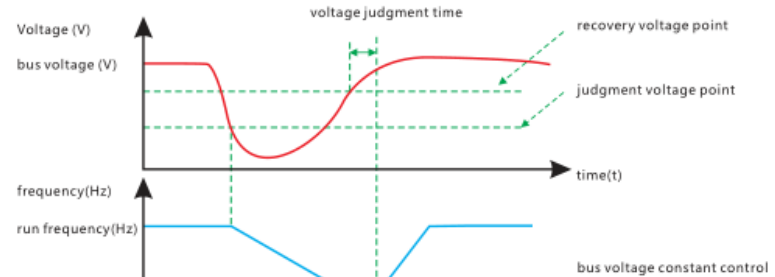

## ▶ Swing frequency control function

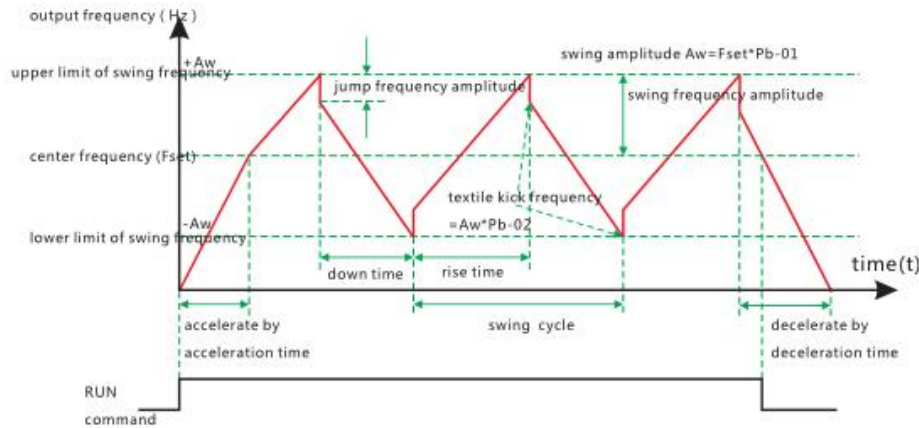

## ▶ Simple PLC

## ▶ Multiple motor switch

Two groups of motor parameters, and control two motors by one inverter.



تهران، کیلومتر ۲۱ بزرگراه لشگری (جاده مخصوص کرج)

روبروی پالایشگاه نفت پارس، پلاک ۱۲

www.famcocorp.com

E-mail: info@famcocorp.com

@famco\_group

Tel: ۰۲۱-۴۸۰۰۰۰۴۹

Fax: ۰۲۱-۴۴۹۹۴۶۴۲

## FS50L Series VFD



### FS50L Series Synchronous Servo Drive

FS50L series high functional synchronous servo drive is specially for speed and torque control of three phase AC permanent magnet synchronous motor, it can open loop vector control without encoder



#### APPLICATION



[www.famcocorp.com](http://www.famcocorp.com)

E-mail: [info@famcocorp.com](mailto:info@famcocorp.com)

@famco\_group

Tel: ۰۲۱-۴۸۰۰۰۰۴۹

Fax: ۰۲۱-۴۴۹۹۴۶۴۲

تهران، کیلومتر ۲۱ بزرگراه لشگری (جاده مخصوص کرج)

روبروی پالایشگاه نفت پارس، پلاک ۱۲

F100 series VFD

**FAMCO**  
هایپر صنعت

# F100 series



[www.famcocorp.com](http://www.famcocorp.com)

E-mail: [info@famcocorp.com](mailto:info@famcocorp.com)

[@famco\\_group](https://www.instagram.com/famco_group)

Tel: ۰۲۱-۴۸۰۰۰۰۴۹

Fax: ۰۲۱-۴۴۹۹۴۶۴۲

تهران، کیلومتر ۲۱ بزرگراه لشگری (جاده مخصوص کرج)

روبروی پالایشگاه نفت پارس، پلاک ۱۲

## Lower cost performance:

all the extra terminals on the client side cannot be used enough, but you have to pay for it .

## Insufficient compatibility:

the inverter purchased by the customer can only be applied to synchronous or asynchronous motors;

## The parameters are cumbersome:

the manual parameters are cumbersome and even up to thousands of parameters. Customers need to find them one by one when using the parameters themselves. Very skilled senior engineers and R&D engineers can't apply them well on the customer site;

**Solve  
industry  
problems**

## F100 series VFD

[www.famcocorp.com](http://www.famcocorp.com)

E-mail: [info@famcocorp.com](mailto:info@famcocorp.com)

@famco\_group

Tel: ۰۲۱-۴۸۰۰۰۰۴۹

Fax : ۰۲۱ - ۴۴۹۹۴۶۴۲

تهران ، کیلومتر ۲۱ بزرگراه لشگری (جاده مخصوص کرج)

روبروی پالایشگاه نفت پارس ، پلاک ۱۲

# F100 series VFD

Mass production has been achieved from 0.75KW-37KW, and by the end of November 2013, 30,000 units have been applied to customer sites.

It is expected that the 45KW-132KW mid-power inverter will be launched and mass production will be realized at the end of March next year.



[www.famcocorp.com](http://www.famcocorp.com)

E-mail: [info@famcocorp.com](mailto:info@famcocorp.com)

@famco\_group

Tel: ۰۲۱-۴۸۰۰۰۰۴۹

Fax: ۰۲۱-۴۴۹۹۴۶۴۲

تهران، کیلومتر ۲۱ بزرگراه لشگری (جاده مخصوص کرج)

روبروی پالایشگاه نفت پارس، پلاک ۱۲



# F100 series VFD

**FAMCO**  
هایپر صنعت

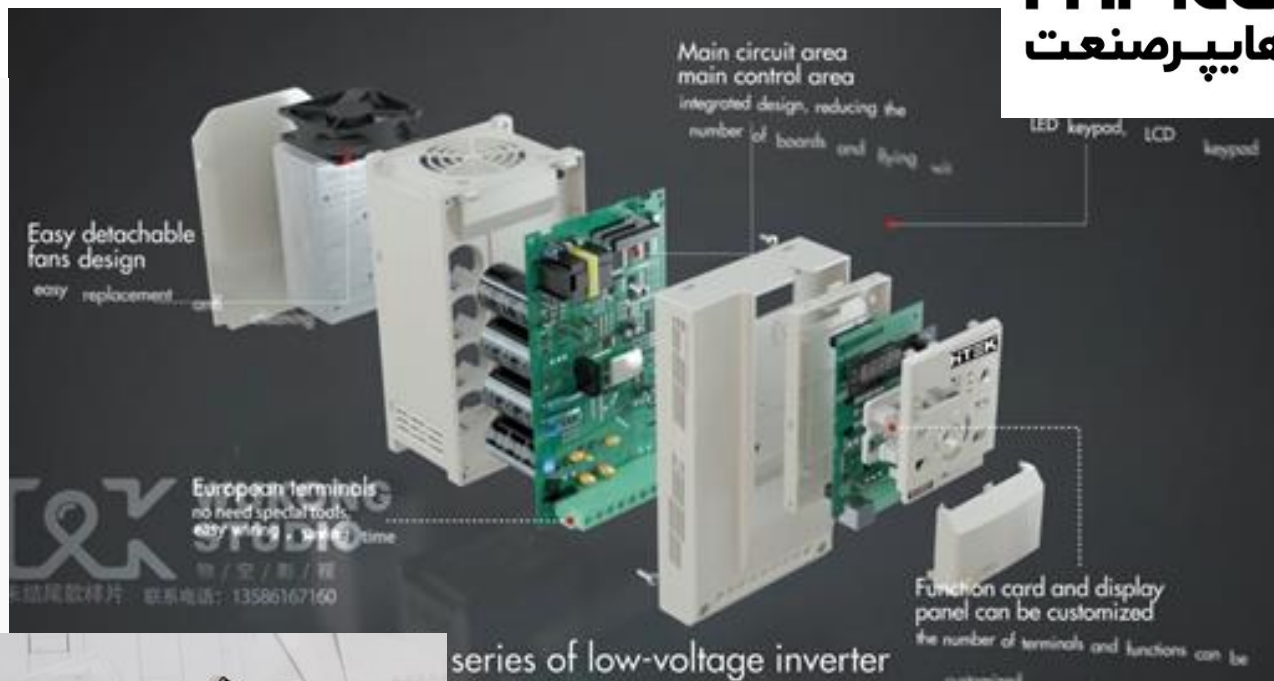

www.famcocorp.com

E-mail: info@famcocorp.com

@famco\_group

Tel: ۰۲۱-۴۸۰۰۰۰۴۹

Fax: ۰۲۱-۴۴۹۹۴۶۴۲

تهران، کیلومتر ۲۱ بزرگراه لشگری (جاده مخصوص کرج)

روبروی پالایشگاه نفت پارس، پلاک ۱۲

## Product appearance introduction



### Function Card

Press to remove it easily and can replace it with customized function card

⚠️ Plug and unplug with power is strictly prohibited



### Abundant display

LED keypad, LCD keypad



### Easy detachable fan design

easy to replace, easy to clean, long life



### Independent air duct

Reliable heat dissipation  
high protection level



### Customized terminal

Customization cost rationalization  
according to industry characteristics  
and customer demands



www.famcocorp.com

E-mail: info@famcocorp.com

@famco\_group

Tel: ۰۲۱-۴۸۰۰۰۰۴۹

Fax: ۰۲۱-۴۴۹۹۴۶۴۲

تهران، کیلومتر ۲۱ بزرگراه لشگری (جاده مخصوص کرج)

روبروی پالایشگاه نفت پارس، پلاک ۱۲

## Multi-function



### One machine has multiple purposes:

This product has various control methods such as V/F control, speed sensor less vector control, etc. It is suitable for synchronous motors, permanent magnet synchronous motors,

[www.famcocorp.com](http://www.famcocorp.com)

E-mail: [info@famcocorp.com](mailto:info@famcocorp.com)

@famco\_group

Tel: ۰۲۱-۴۸۰۰۰۰۴۹

Fax: ۰۲۱-۴۴۹۹۴۶۴۲

تهران، کیلومتر ۲۱ بزرگراه لشگری (جاده مخصوص کرج)

روبروی پالایشگاه نفت پارس، پلاک ۱۲

## sufficient

The F100 series inverter panel deeply combines the functional needs of various industries. Different panels have different functional terminals to meet some specific industry applications. Therefore, customers choose multi-function panels with different configurations according to their own needs. Users do not need to pay for redundant function terminals. At the same time, the main circuit terminals, modules, capacitors and other main circuit components are adequately used and refined to ensure product quality and reliability.



## easy to use

F100 series inverters have super self-adaptive ability, and have a variety of industry application macro parameters. Built-in powerful and flexible terminal setting function and built-in PLC function can meet most industry applications.

The special algorithm using adaptive vector control technology ensures the convenience of VF.

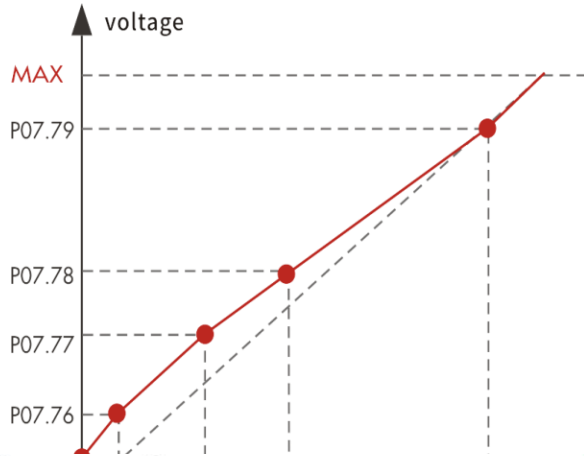

Simple to use: select the source of the terminal according to the required function, saving the number and type of the terminal.

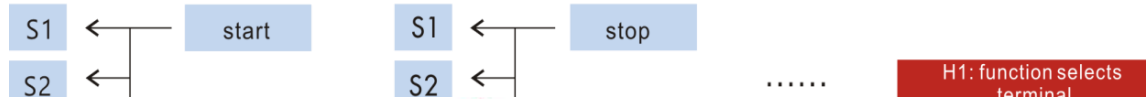
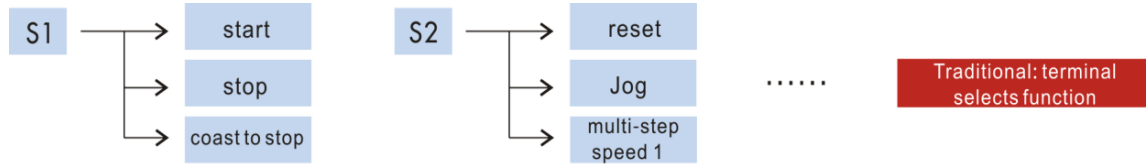

easy to use

## Flexible function:

The setting value and command combination are flexible, and it can be easily matched with different applications.

## Quick parameter setting function:

Custom parameters P0.00-P0.99 total 100 parameters. Customers can set corresponding parameters according to their common parameters and habits to realize the custom function of parameters.

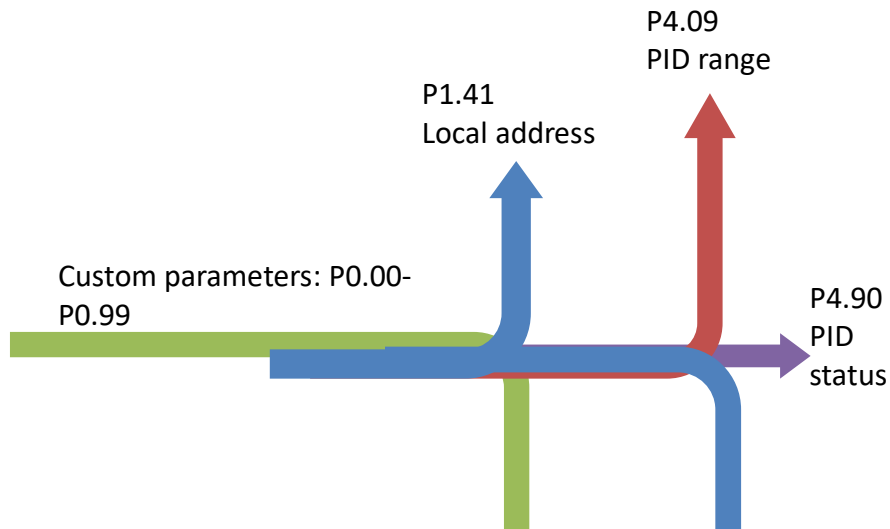
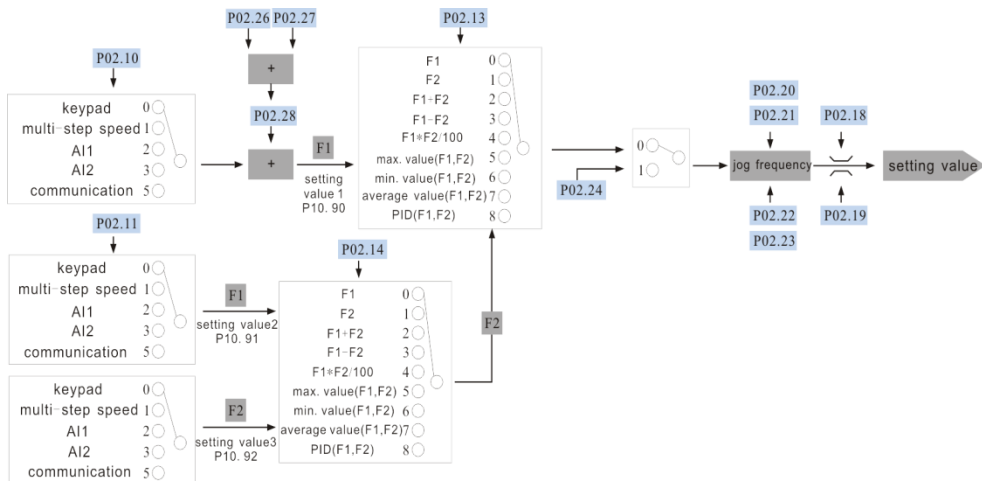

easy to use



Custom M key function and indicator function

## performance characteristics

High carrier frequency  
Maximum 16KHz, n

F100 series inverter can adapt to 80% of most standard motors on the market in adaptive vector control algorithm.

### Fast current control:

High dynamic response speed (15ms), fast starting speed, small speed fluctuation

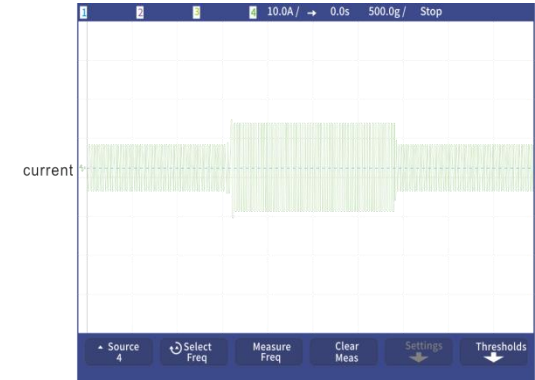
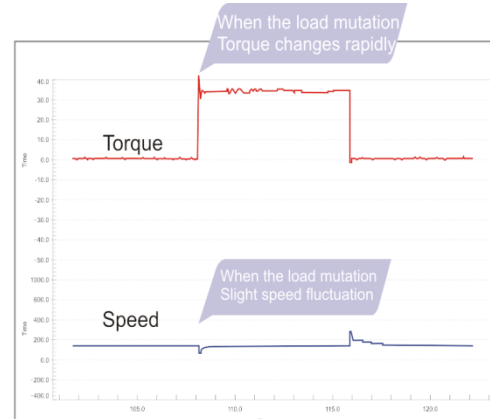
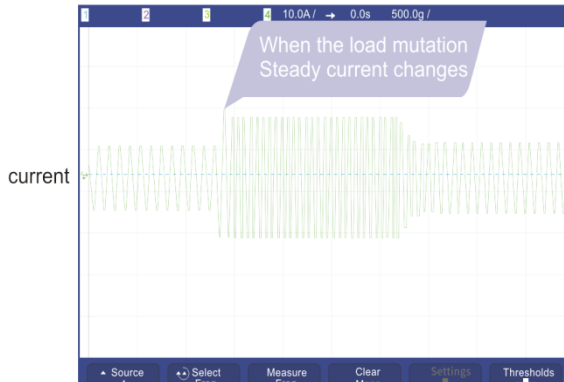
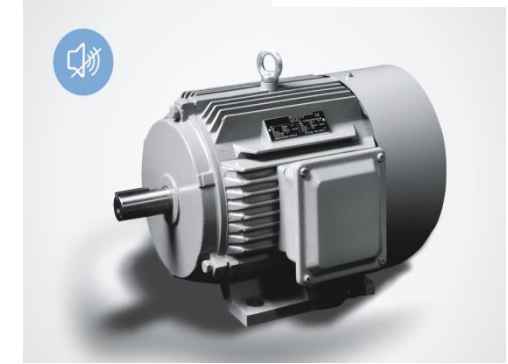



# F100 series VFD

## structure and function characteristics

Picture 1

Compared with traditional inverters, the F100 series is smaller in size, saving up to 30% of the installation space and effectively improving the efficiency of space.



Picture 1

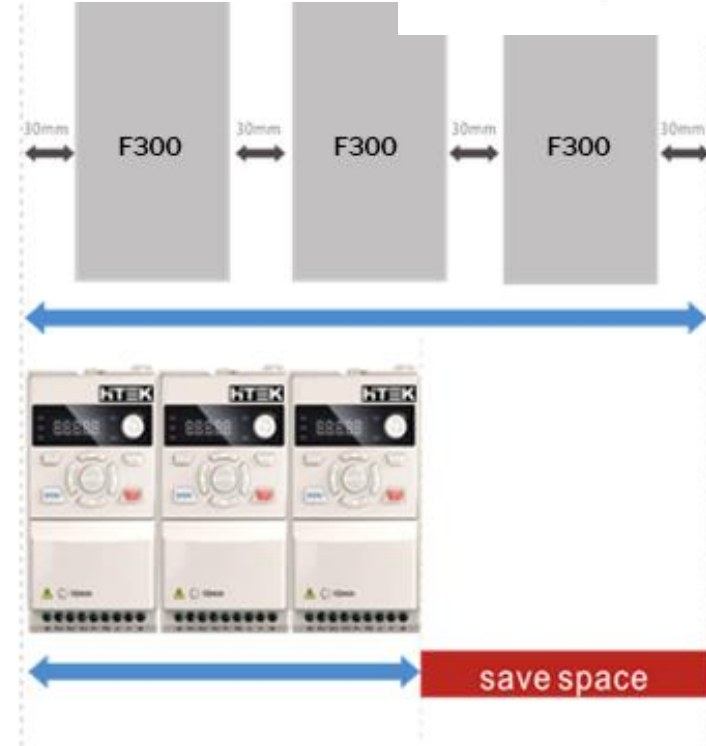

Picture 2

Picture 2

Support seamless installation side by side, provide high configuration flexibility and improve installation efficiency.

www.famcocorp.com

E-mail: info@famcocorp.com

@famco\_group

Tel: ۰۲۱-۴۸۰۰۰۰۴۹

Fax: ۰۲۱-۴۴۹۹۴۶۴۲

تهران، کیلومتر ۲۱ بزرگراه لشگری (جاده مخصوص کرج)

روبروی پالایشگاه نفت پارس، پلاک ۱۲

## structure and function characteristics



**Independent air duct:**  
There is no forced wind to flow through the components, which improves environmental

[www.famcocorp.com](http://www.famcocorp.com)

E-mail: [info@famcocorp.com](mailto:info@famcocorp.com)

@famco\_group

## Three-in-one keyboard



Tel: ۰۲۱-۴۸۰۰۰۰۴۹

Fax: ۰۲۱-۴۴۹۹۴۶۴۲



**Fast and tight protection:**  
Short circuit fault, input/output phase loss, overload, leakage, etc., comprehensively protect the inverter and motor

تهران، کیلومتر ۲۱ بزرگراه لشگری (جاده مخصوص کرج)

روبروی پالایشگاه نفت پارس، پلاک ۱۲



## Application case



F100 standard function

[www.famcocorp.com](http://www.famcocorp.com)

E-mail: [info@famcocorp.com](mailto:info@famcocorp.com)

@famco\_group



Industry customization, high cost performance

Tel: ۰۲۱-۴۸۰۰۰۰۴۹

Fax: ۰۲۱-۴۴۹۹۴۶۴۲

تهران، کیلومتر ۲۱ بزرگراه لشگری (جاده مخصوص کرج)

روبروی پالایشگاه نفت پارس، پلاک ۱۲

## Application case

01

Air compressor

02

Engraving machine

03

solar pump



Wire cutting

04

Industrial washing machine

05

General industry

06

[www.famcocorp.com](http://www.famcocorp.com)

E-mail: [info@famcocorp.com](mailto:info@famcocorp.com)

@famco\_group

Tel: ۰۲۱-۴۸۰۰۰۰۴۹

Fax: ۰۲۱-۴۴۹۹۴۶۴۲

تهران، کیلومتر ۲۱ بزرگراه لشگری (جاده مخصوص کرج)

روبروی پالایشگاه نفت پارس، پلاک ۱۲

## Application case

F0101 function card



Terminal function	Terminal name	Terminal description
10V power supply	+10V	Provide +10V power supply to the outside
Analog input	AI1 (1 way)	0~10V or 0~20mA Select by SW1 jumper
Digital and analog ground terminal	COM	
Digital input terminal	S1~S4 (4 way)	
Reserved	N.C.	
Relay output	RA,RB	Normally open
485 communication port	RJ45	External keyboard or connect to host computer

www.famcocorp.com

E-mail: info@famcocorp.com

@famco\_group

Tel: ۰۲۱-۴۸۰۰۰۰۴۹

Fax: ۰۲۱-۴۴۹۹۴۶۴۲

تهران، کیلومتر ۲۱ بزرگراه لشگری (جاده مخصوص کرج)

روبروی پالایشگاه نفت پارس، پلاک ۱۲

## Application case

F0100 function card



SW1  
jumper

Terminal function	Terminal name	Terminal description
485 communication port	SG+,SG-	connect to host computer
10V power supply	+10V	Provide +10V power supply to the outside
Analog input	AI1 (one)	0~10V or 0~20mA Select by SW1 jumper
Digital and analog ground terminal	COM	
Digital input terminal	S1~S2 (two)	
Relay output	RA, RB, RC	One normally open, one normally closed

## Application case



Terminal function	Terminal name	Terminal description
10V power supply	+10V	Provide +10V power supply to the outside
12V power supply	+EV	Provide +12V power supply to the outside
Analog input	AI1 (1 way)	0~10V or 0~20mA Select by SW1 jumper
Analog output	AO1 (1 way)	0~10V or 0~20mA Select by SW2 jumper
Digital and analog ground terminal	COM	
Digital input terminal	S1~S8 (8 way)	
Digital input terminal & 485 communication terminal	S9~S10 (2 way)	S9, S10 are shared with communication terminals
Relay output Y1	RA1, RB1, RC1	One normally open, one normally closed
Relay output Y2	RA2, RB2	One normally open
Relay output Y3	RA3, RB3	normally open solid state relay

www.famcocorp.com

E-mail: info@famcocorp.com

@famco\_group

Tel: ۰۲۱-۴۸۰۰۰۰۴۹

Fax: ۰۲۱-۴۴۹۹۴۶۴۲

تهران، کیلومتر ۲۱ بزرگراه لشگری (جاده مخصوص کرج)

روبروی پالایشگاه نفت پارس، پلاک ۱۲



## Application case

F0110 function card



Terminal function	Terminal name	Terminal description
10V power supply	+10V	Provide +10V power supply to the outside
Analog input	AI1 (1 way)	0~10V or 0~20mA Select by SW1 jumper
Analog output	AO1 (1 way)	0~10V or 0~20mA Select by SW1 jumper
Analog output	AO2 (1 way)	0~10V or 0~20mA Select by SW1 jumper
Digital and analog ground terminal	COM	
Digital input terminal	S1~S5 (5 way)	
Relay output Y1	RA1,RB1,RC1	One normally open, one normally closed
Relay output Y2	RA2,RB2	One normally open
485 communication terminal	SG+,SG-	There are a total of 485 slave stations, and two master stations cannot be connected at the same time
485 communication	RJ45	

www.famcocorp.com

E-mail: info@famcocorp.com

@famco\_group

Tel: ۰۲۱-۴۸۰۰۰۰۴۹

Fax: ۰۲۱-۴۴۹۹۴۶۴۲

تهران، کیلومتر ۲۱ بزرگراه لشگری (جاده مخصوص کرج)

روبروی پالایشگاه نفت پارس، پلاک ۱۲

## Application case

### F0200 function card



Terminal Function	Terminal Name	Description
Digital input terminal	S1~S9 (9 way)	
High-speed pulse input terminal	S10 (1 way)	
Digital and analog ground terminal	COM	
External power input terminal	OP	
10V power supply	+10V	Provide +10V power supply to the outside
12V power supply	+EV	Provide +12V power supply to the outside
Analog input 1	AI1 (1 way)	0~10V or 0~20mA Select by dial switch, dial down for voltage signal, dial up for current signal
Analog input 2	AI2 (1 way)	
Analog current output 1	AO1_I (1 way)	0~20mA
Analog voltage output 1	AO1_V (1 way)	0~10V
Analog current output 2	AO2_I (1 way)	0~20mA
Analog voltage output 2	AO2_V (1 way)	0~10V
Relay output Y1	RA1,RB1	One normally open
Relay output Y2	RA2,RB2	One normally open
Relay output Y3	RA3,RB3,RC3	One normally open, one normally closed
STO1	STI1	

## Application case

### F0300 function card



There are no input and output terminals, and it can run after power-on. The panel has only one-key start button.

F0300 panel was successfully applied to the special plane of the photovoltaic water pump industry.

## Application case

### F0310 function card

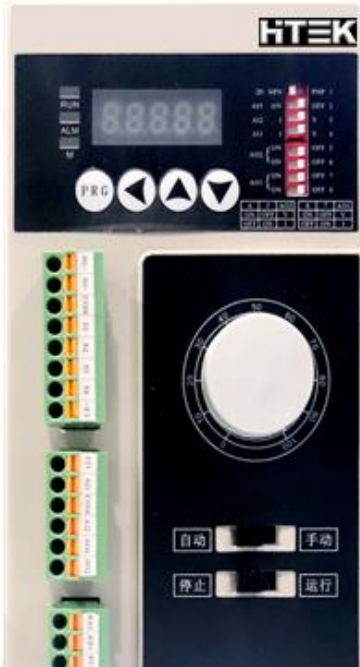

Terminal function	Terminal name	Terminal description
485 communication terminal	SG+,SG-	connect to host computer
Digital and analog ground terminal	COM	
Digital input terminal	S1~S4 (4 way)	
10V power supply	+10V	Provide +10V power supply to the outside
12V power supply	+EV	Provide +12V power supply to the outside
Analog input 1	AI1 (1 way)	0~10V or 0~20mA
Analog input 2	AI2 (1 way)	Select by dial switch, dial down for voltage signal, dial up for current signal
Analog output 1	AO1 (1 way)	0~10V or 0~20mA
Analog output 2	AO2 (1 way)	Use the AO1 and AO2 dial switches to select left, dial 5 and 7 for current signal, dial 6 and 8 for voltage signal

www.famcocorp.com

E-mail: info@famcocorp.com

@famco\_group

Tel: ۰۲۱-۴۸۰۰۰۰۴۹

Fax: ۰۲۱-۴۴۹۹۴۶۴۲

تهران، کیلومتر ۲۱ بزرگراه لشگری (جاده مخصوص کرج)

روبروی پالایشگاه نفت پارس، پلاک ۱۲

## Application case

F0320 function card



Terminal function	Terminal name	Terminal description
485 communication terminal	SG+,SG-	connect to host computer
Digital and analog ground terminal	COM	
Digital input terminal	S1~S5 (5 way)	
10V power supply	+10V	Provide +10V power supply to the outside
Analog input	AI1 (4 way)	0~10V or 0~20mA It is selected by the AI1 and AI2 dial switches, the left is the current signal, the right is the voltage signal
Analog output	AO1 (4 way)	0~10V or 0~20mA
Analog output	AO2 (4 way)	Use the AO1 and AO2 dial switches to select left, dial 5 and 7 for current signal, dial 6 and 8 for voltage signal

www.famcocorp.com

E-mail: info@famcocorp.com

@famco\_group

Tel: ۰۲۱-۴۸۰۰۰۰۴۹

Fax: ۰۲۱-۴۴۹۹۴۶۴۲

تهران، کیلومتر ۲۱ بزرگراه لشگری (جاده مخصوص کرج)

روبروی پالایشگاه نفت پارس، پلاک ۱۲

## F105 LCD function card



- widely used in textile machine, packing machine, carving machine, printing machine, solar water pump, food machinery, woodworking machinery, water pump fan and ceramic machinery, providing better solution

www.famcocorp.com

E-mail: info@famcocorp.com

@famco\_group

Tel: ۰۲۱-۴۸۰۰۰۰۴۹

Fax: ۰۲۱-۴۴۹۹۴۶۴۲

تهران، کیلومتر ۲۱ بزرگراه لشگری (جاده مخصوص کرج)

روبروی پالایشگاه نفت پارس، پلاک ۱۲

## Part 03

# Hitek Medium-Voltage Inverter

The user can demonstrate on a projector or computer, or presentation and make it film to be used in a wider field

[www.famcocorp.com](http://www.famcocorp.com)

E-mail: [info@famcocorp.com](mailto:info@famcocorp.com)

@famco\_group

Tel: ۰۲۱-۴۸۰۰۰۰۴۹

Fax: ۰۲۱-۴۴۹۹۴۶۴۲

تهران، کیلومتر ۲۱ بزرگراه لشگری (جاده مخصوص کرج)

روبروی پالایشگاه نفت پارس، پلاک ۱۲

## Medium voltage VFD



www.famcocorp.com

E-mail: info@famcocorp.com

@famco\_group

Tel: ۰۲۱-۴۸۰۰۰۰۴۹

Fax: ۰۲۱-۴۴۹۹۴۶۴۲

تهران، کیلومتر ۲۱ بزرگراه لشگری (جاده مخصوص کرج)

روبروی پالایشگاه نفت پارس، پلاک ۱۲



## product series:

### 3KV series:

400-8000KVA, adapted motor 315-6400KW

### 6KV/6.6KV series:

400-16000KVA, adapted motor 315-13000KW

### 10KV series:

400-20000KVA, adapted motor 315-16000KW

## Products and production capacity

Hitek has independent intellectual property rights of series vector low-voltage inverter, series intelligent high-voltage frequency conversion speed regulating device, and has obtained a number of invention patents and utility model patents. Hitek series high and low voltage frequency conversion products are widely used in electric power, metallurgy, petrochemical, coal, municipal, cement, paper, pharmaceutical and other fields, effectively improving the energy efficiency, process control and automation level of industrial enterprises.

The dual DSP+FPGA collaborative control method independently developed by the company adopts the original asymmetrical PWM technology. The harmonic content on the grid side and the motor side is very low, and the total harmonic distortion rate is only 0.8~2%, which is much lower than the same industry. The total harmonic distortion rate is 1.5%~3%. The original local neutral point offset technology can maximize the use of normal units and improve the output capacity in case of failure. The product has passed the national scientific and technological achievements appraisal jointly composed of the Chinese Academy of Sciences, the Design Institute of the Second Research Institute of Nuclear Industry, the Electrical Technology Research Institute, and the Metallurgical Automation Research Institute, and has obtained the "National High-tech Product" certification. .

 [www.famcocorp.com](http://www.famcocorp.com)

 E-mail: [info@famcocorp.com](mailto:info@famcocorp.com)

 [@famco\\_group](https://www.instagram.com/famco_group)

 Tel: ۰۲۱-۴۸۰۰۰۰۴۹

 Fax: ۰۲۱-۴۴۹۹۴۶۴۲

تهران، کیلومتر ۲۱ بزرگراه لشگری (جاده مخصوص کرج)

روبروی پالایشگاه نفت پارس، پلاک ۱۲

## Front view of high voltage inverter



www.famcocorp.com

E-mail: info@famcocorp.com

@famco\_group

Tel: ۰۲۱-۴۸۰۰۰۰۴۹

Fax: ۰۲۱-۴۴۹۹۴۶۴۲

تهران، کیلومتر ۲۱ بزرگراه لشگری (جاده مخصوص کرج)

روبروی پالایشگاه نفت پارس، پلاک ۱۲

## System structure diagram

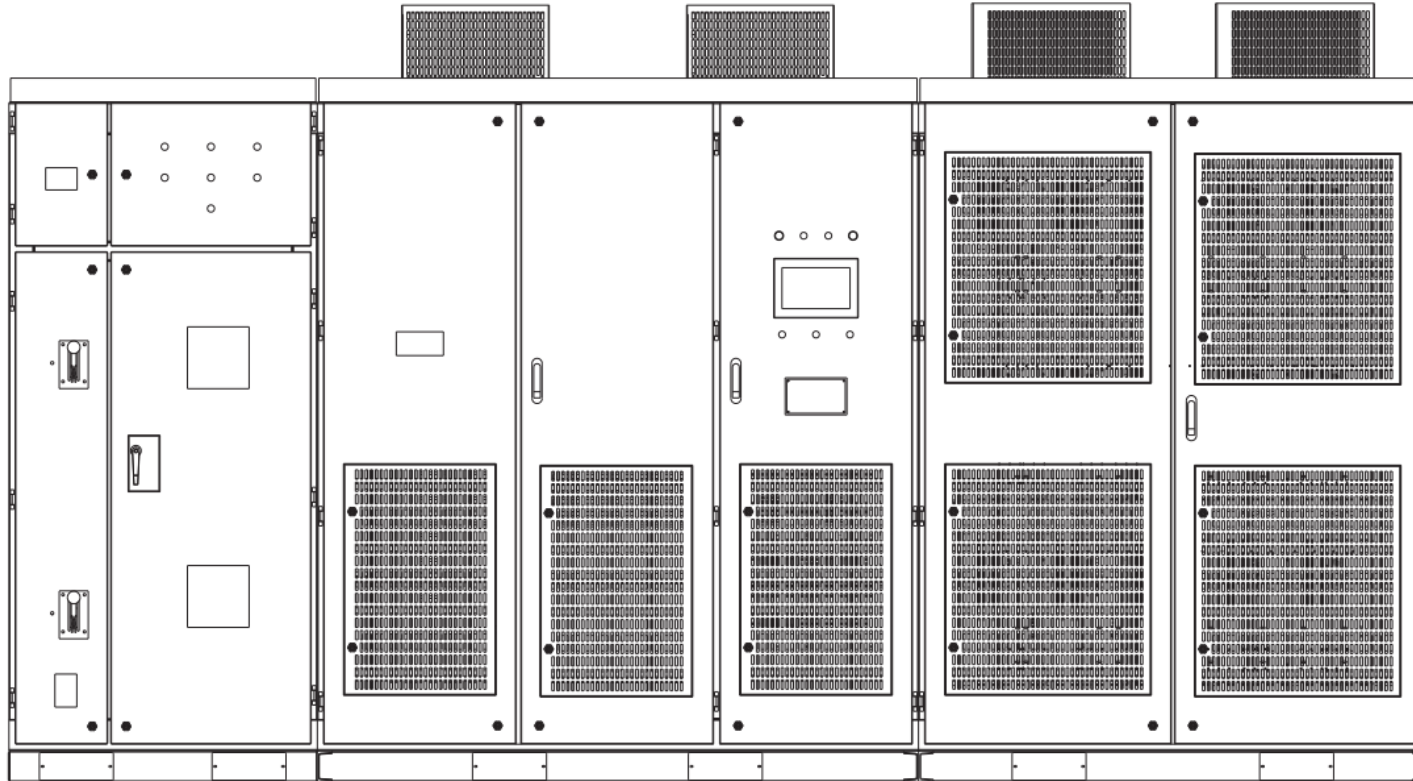

Dress switch

[www.famcocorp.com](http://www.famcocorp.com)

E-mail: [info@famcocorp.com](mailto:info@famcocorp.com)

@famco\_group

Tel: ۰۲۱-۴۸۰۰۰۰۴۹

Fax: ۰۲۱-۴۴۹۹۴۶۴۲

تهران، کیلومتر ۲۱ بزرگراه لشگری (جاده مخصوص کرج)

روبروی پالایشگاه نفت پارس، پلاک ۱۲

## Smart operation interface diagram



图4-5



## Structure (transformer cabinet)

Phase shifting transformer

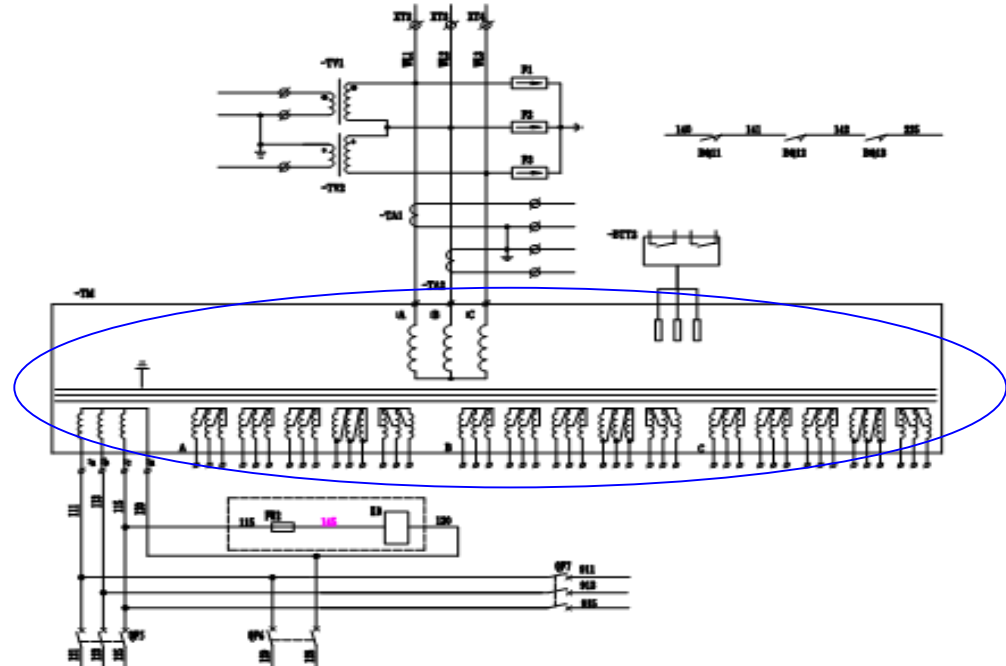

## Structure (transformer cabinet)

## Temperature Controller

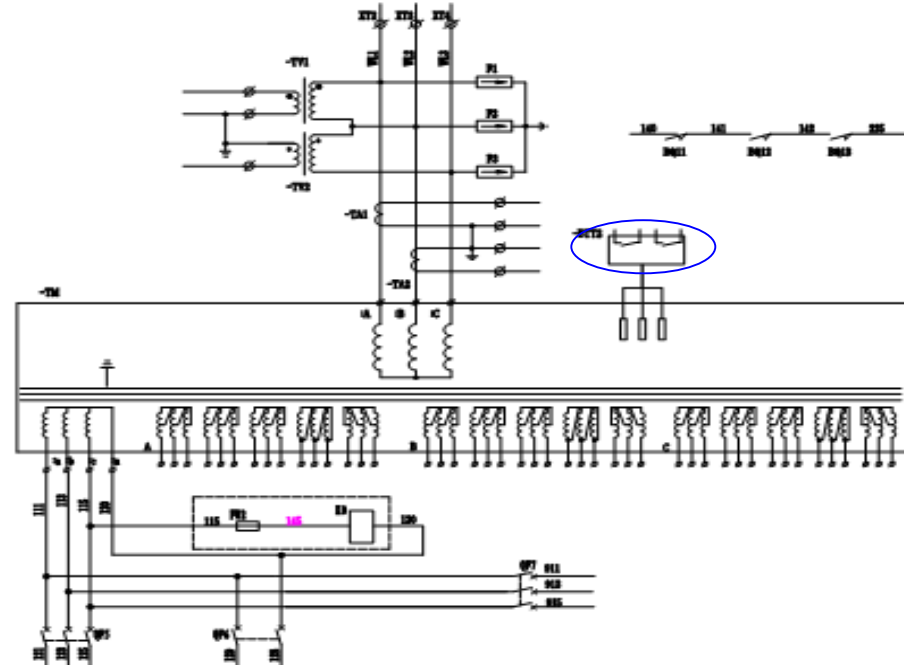

## Structure (transformer cabinet)

### Cabinet bottom fan

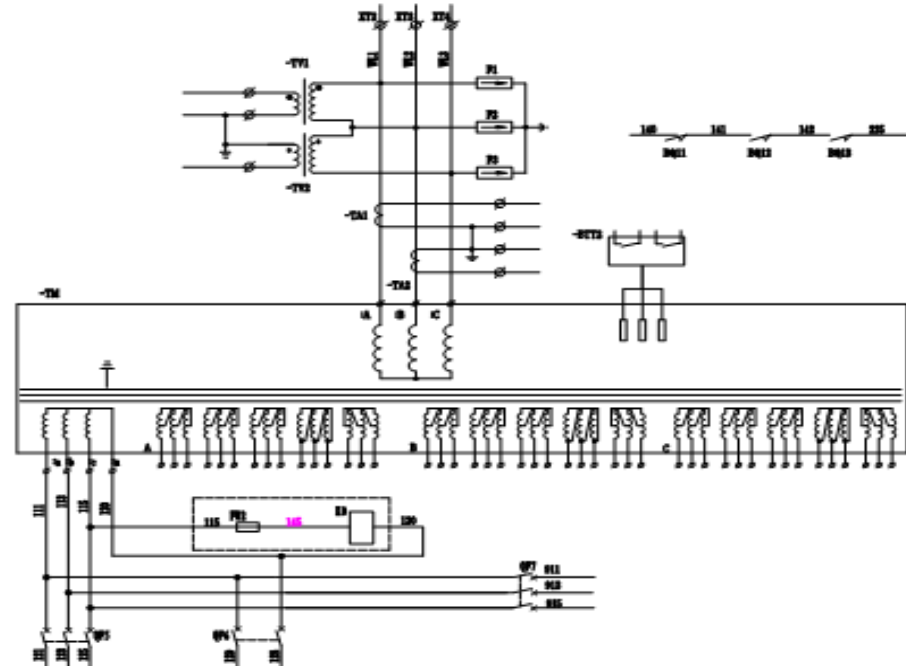
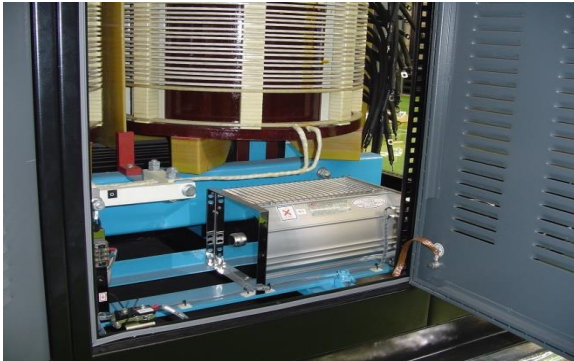



## Structure (transformer cabinet)

### Cabinet roof cooling fan

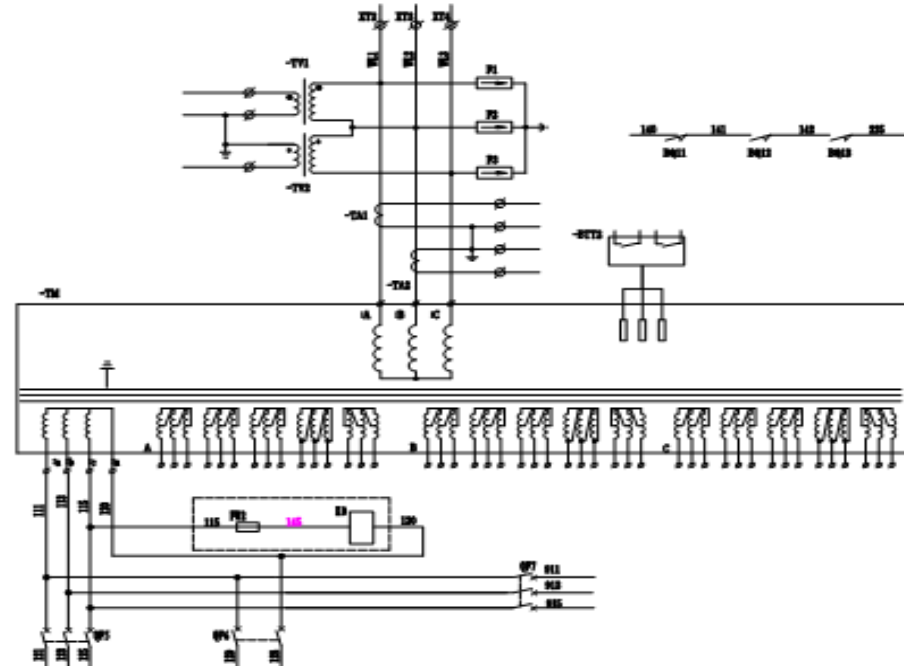

## Structure (Power cabinet)

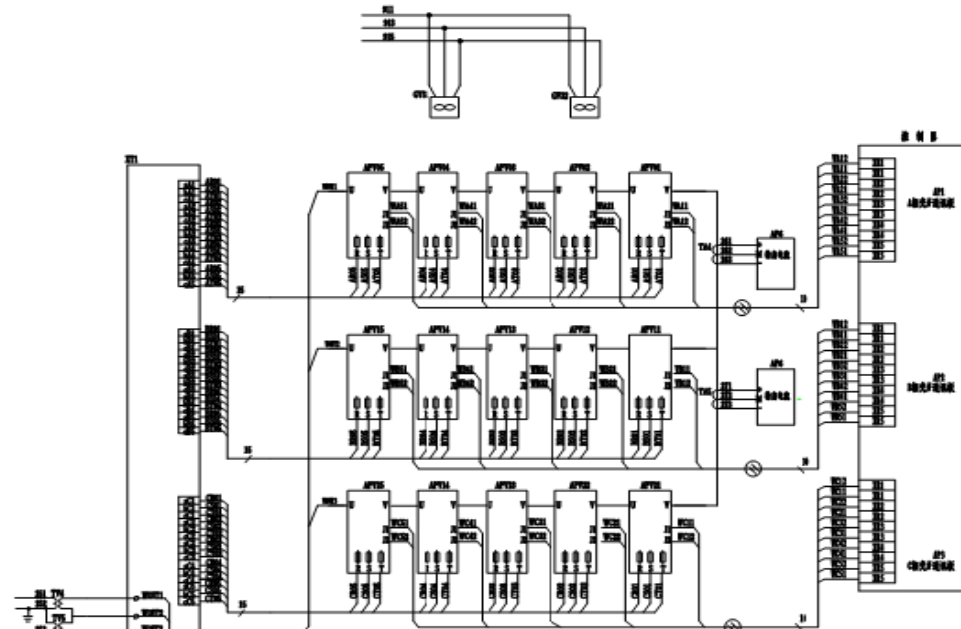

www.famcocorp.com

E-mail: info@famcocorp.com

@famco\_group

Tel: ۰۲۱-۴۸۰۰۰۰۴۹

Fax: ۰۲۱-۴۴۹۹۴۶۴۲

تهران، کیلومتر ۲۱ بزرگراه لشگری (جاده مخصوص کرج)

روبروی پالایشگاه نفت پارس، پلاک ۱۲

## Structure (Power cabinet)

### Cooling fan

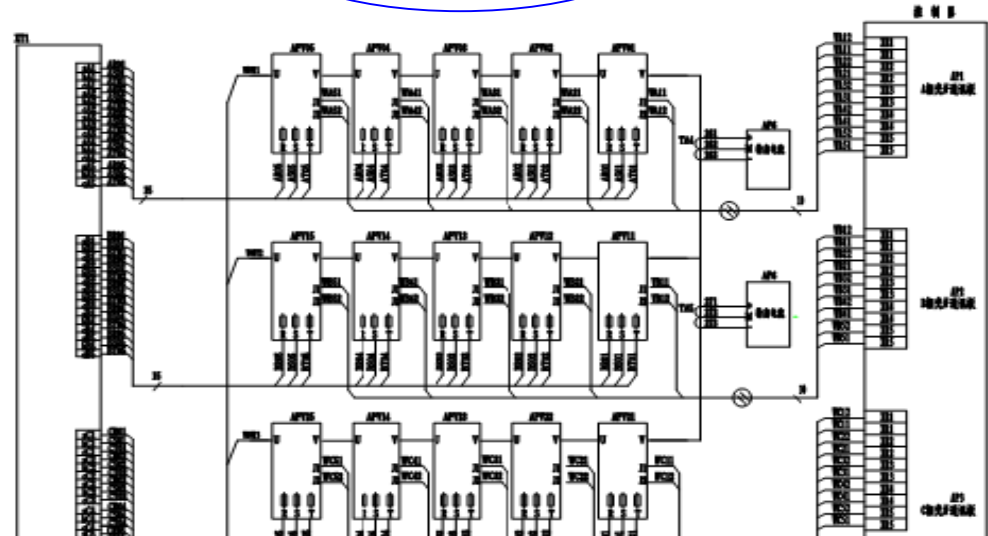
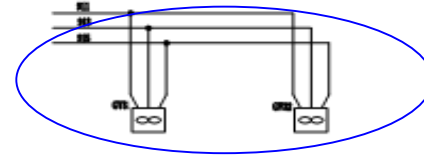

## Structure (Power cabinet)

### Current hall

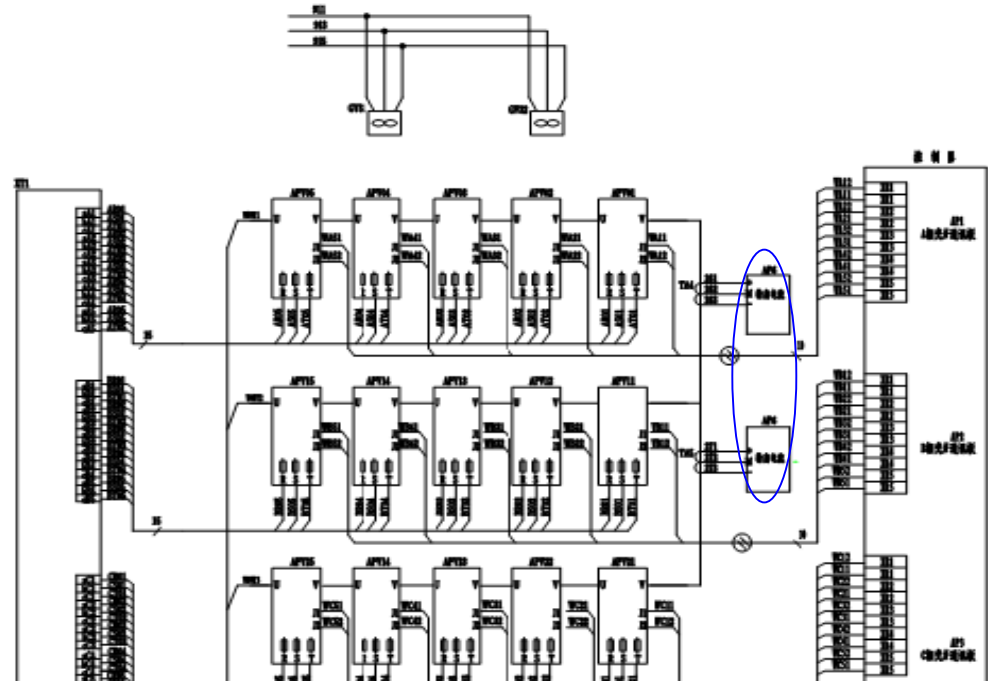

## Structure (Power cabinet)

### Power module

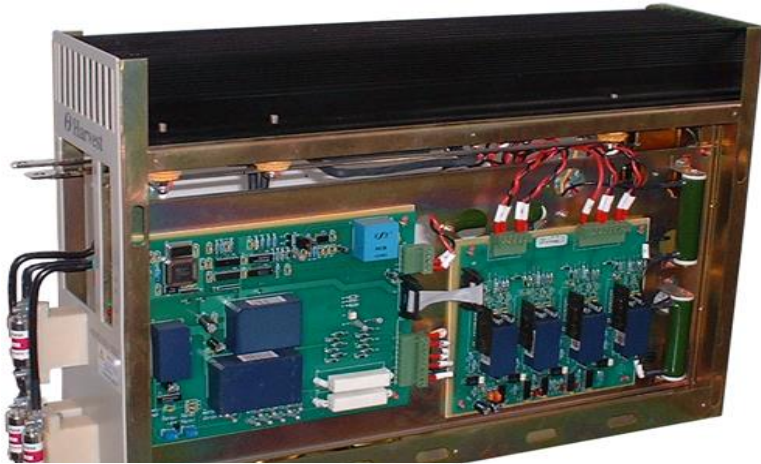

## High-voltage inverter structure (Power cabinet)

### Power module

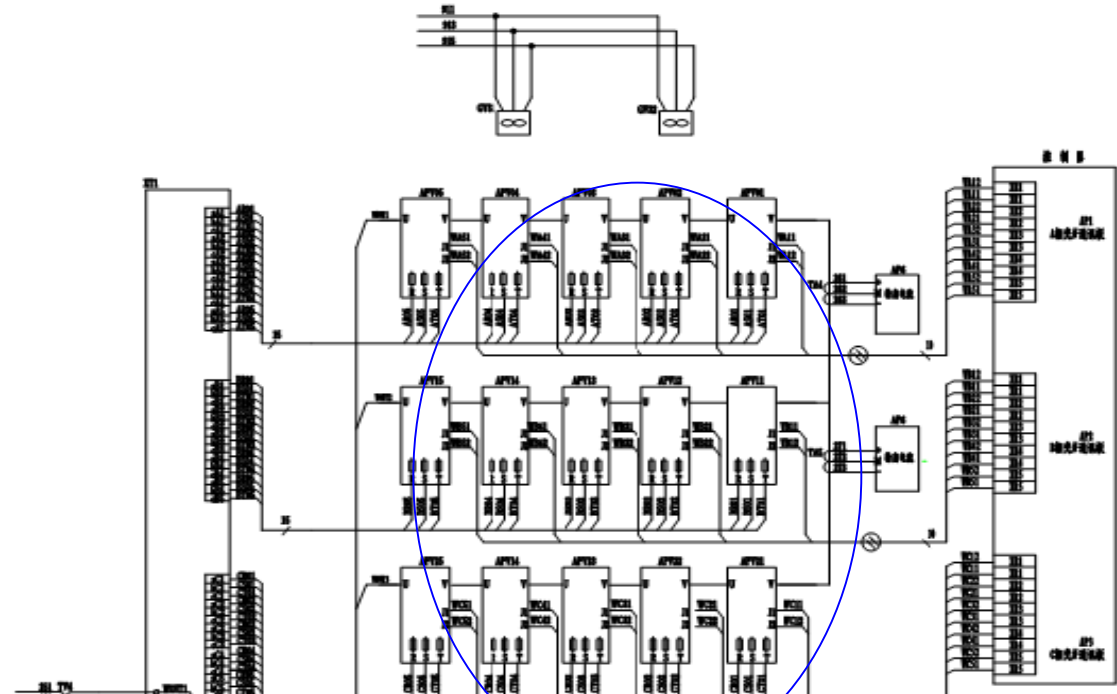

www.famcocorp.com

E-mail: info@famcocorp.com

@famco\_group

Tel: ۰۲۱-۴۸۰۰۰۰۴۹

Fax: ۰۲۱-۴۴۹۹۴۶۴۲

تهران، کیلومتر ۲۱ بزرگراه لشگری (جاده مخصوص کرج)

روبروی پالایشگاه نفت پارس، پلاک ۱۲

## Structure (Control Board)



1. Main control board: Receive and process control commands from industrial computer and PLC through serial port or interface board, and send out its own status information at the same time.

The main control board simultaneously generates the trigger pulses of the power units of each phase at all levels, collects and processes the fault information fed back by all power units, informs the man-machine interface to record faults, and informs the PLC to implement system alarms and protections.

## Power factor improvement to use Hitek MV inverte

The rated input power factor of the high-voltage inverter is greater than 0.95, which is much higher than the power factor of the low-voltage inverter.  
advantage:

- 1) No need for power factor compensation capacitors;
- 2) Reduce reactive power input,
- 3) Reduce power supply capacity.



## High-quality input characteristics---

**input current harmonic content is less than 1% to use Hitek medium-voltage inverter**

The secondary coil of the isolation transformer on the input side of the high-voltage frequency converter is phase-shifted to provide power for the power unit. From a structural point of view, due to the high-power rectifier element used on the input side, it can not only eliminate high-order harmonics and improve the power factor, but also not Affected by power grid fluctuations, it has excellent dynamic performance. The simple working principle of synchronous rectification can be briefly described as follows: the rectifier circuit draws sine wave AC from the grid, and after rectification, it outputs a DC voltage and maintains the required voltage value. The input side has a filter capacitor and a reactor to filter out most of the The harmonic current caused by a single power unit greatly suppresses the generation of grid-side harmonics (especially low-order harmonics). Synchronous rectification circuit and filter circuit ensure that only sine wave voltage or current is drawn from the grid or fed back to the grid, and will not produce 5, 7, 11, 13 harmonics generated by diode rectification, and grid harmonic voltages caused by inverters And the harmonic current content meets the most stringent requirements for the harmonic content of IEEE Std 519-1992 and GB/T 14549-93

"Power Quality Public Grid Harmonics", no need to install input filters and protect peripheral equipment from

 [www.famcocorp.com](http://www.famcocorp.com)

 E-mail: [info@famcocorp.com](mailto:info@famcocorp.com)

 [@famco\\_group](https://www.instagram.com/famco_group)

 Tel: ۰۲۱-۴۸۰۰۰۰۴۹

 Fax : ۰۲۱ - ۴۴۹۹۴۶۴۲

تهران، کیلومتر ۲۱ بزرگراه لشگری (جاده مخصوص کرج)

روبروی پالایشگاه نفت پارس، پلاک ۱۲

## Perfect output characteristics---

**The harmonic content of the output voltage is less than 2% to use Hitek Medium-voltage inverter**

The output side adopts series connection of power units, vector control sine wave pulse width modulation (SPWM) overlapping wave output, using dual DSP + FPGA cooperative control mode to ensure the requirements of high-speed real-time operation and monitoring of the system, and adopts original asymmetrical PWM technology to make the power grid The harmonic content on the side and the motor side is very low. The 10kV series has 9 units per phase, which greatly reduces the output harmonic content. The output waveform is almost perfect sine wave. Compared with other low-voltage large-capacity inverters, it has the following advantages:

- 1) No output filter device is required
- 2) It can drive ordinary high-voltage motors without increasing the temperature rise of the motor and reducing the motor capacity
- 3) There is no limit on the length of the motor cable
- 4) Protect the motor insulation from dv/dt stress damage

 [www.famcocorp.com](http://www.famcocorp.com)

 E-mail: [info@famcocorp.com](mailto:info@famcocorp.com)

 [@famco\\_group](https://www.instagram.com/famco_group)

 Tel: ۰۲۱-۴۸۰۰۰۰۴۹

 Fax : ۰۲۱ - ۴۴۹۹۴۶۴۲

تهران، کیلومتر ۲۱ بزرگراه لشگری (جاده مخصوص کرج)

روبروی پالایشگاه نفت پارس، پلاک ۱۲

## Significantly improved reliability to use Hitek high voltage inver

From research and development, production to complete machine testing, LPMV series inverters put reliability in the first place in every link to ensure the safety and reliability of users.

- 1) Principle design: LPMV adopts advanced power unit series stacking (also known as power unit multiple structure) method, space vector control sine wave PWM modulation method, using mature low-voltage inverter technology and power device IGBT, from the principle This ensures the reliability of the system and greatly improves the input and output waveforms of the inverter. In the United States, this type of inverter is known as a perfect harmonic-free inverter. Optical fiber communication is used between the power unit and the control system to achieve complete electrical isolation between strong and weak currents and improve the anti-interference ability of the entire system. Two bypass operation modes: unit bypass and power frequency bypass. Even if the inverter fails, the motor can still be operated by corresponding means without affecting production.
- 2) Selection of components: In order to ensure the reliability and service life of the system, the main components are all products from well-known international manufacturers.
- 3) Complete quality assurance system: The company has formed a complete quality management system, which has

passed ISO9001:2000 certification. The company strictly controls quality in supplier certification, component

## Other features and advantages to use Hitek Medium-Voltage inverter

- 1) High reliability, mature technology, high reliability and high quality inverter.
- 2) The power unit has a modular structure, which can be interchanged and is easy to maintain.
- 3) The wide input voltage range is more suitable for domestic power grid conditions.
- 4) The optical fiber communication control of the power unit is completely electrically isolated.
- 5) Flexible and powerful communication function, isolated RS485 interface, using MODBUS RTU, PROFIBUS-DP industrial Ethernet communication protocol.
- 6) There are three control modes: local, remote and upper position.

## Other features and advantages to use Hitek Medium-Voltage inverter.

- 7) Comprehensive fault monitoring circuit, timely fault alarm protection and accurate fault record preservation.
- 8) Special designs can be made according to user requirements.
- 9) Modular design, compact structure, convenient maintenance, and enhanced product interchangeability.
- 10) Direct high voltage output without output transformer.
- 11) Very low  $dv/dt$  output, without any form of filter.
- 12) The use of optical fiber communication technology improves the anti-interference ability and reliability of the product.

# Part 03

## Solutions and Applications

The user can demonstrate on a projector or computer, or presentation and make it film to be used in a wider field

[www.famcocorp.com](http://www.famcocorp.com)

E-mail: [info@famcocorp.com](mailto:info@famcocorp.com)

@famco\_group

Tel: ۰۲۱-۴۸۰۰۰۰۴۹

Fax: ۰۲۱ - ۴۴۹۹۴۶۴۲

تهران، کیلومتر ۲۱ بزرگراه لشگری (جاده مخصوص کرج)

روبروی پالایشگاه نفت پارس، پلاک ۱۲

## POWER



- ✓ Supply water pump
- ✓ Fans
- ✓ Condensate pump
- ✓ Circulating pump

## Metallurgical industry



- ✓ Fans
- ✓ Ash pump
- ✓ Phosphorus removal pump

## Coal industry



- ✓ Hoist
- ✓ Belt conveyor
- ✓ Fans
- ✓ pump

www.famcocorp.com

E-mail: info@famcocorp.com

@famco\_group

Tel: ۰۲۱-۴۸۰۰۰۰۴۹

Fax: ۰۲۱-۴۴۹۹۴۶۴۲

تهران، کیلومتر ۲۱ بزرگراه لشگری (جاده مخصوص کرج)

روبروی پالایشگاه نفت پارس، پلاک ۱۲

## Petrochemical industry



- ✓ Fans
- ✓ Extruder
- ✓ pump
- ✓ Main pipeline pump

## Cement industry



- ✓ High temperature fan
- ✓ Fans
- ✓ Circulating fan for raw mill

[www.famcocorp.com](http://www.famcocorp.com)

E-mail: [info@famcocorp.com](mailto:info@famcocorp.com)

@famco\_group

Tel: ۰۲۱-۴۸۰۰۰۰۴۹

Fax: ۰۲۱-۴۴۹۹۴۶۴۲

تهران، کیلومتر ۲۱ بزرگراه لشگری (جاده مخصوص کرج)

روبروی پالایشگاه نفت پارس، پلاک ۱۲



# High-Voltage inverter application

**FAMCO**  
هایپر صنعت

## Application of High-Voltage Frequency Converter in Power Industry



www.famcocorp.com

E-mail: info@famcocorp.com

@famco\_group

Tel: ۰۲۱-۴۸۰۰۰۰۴۹

Fax: ۰۲۱-۴۴۹۹۴۶۴۲

تهران، کیلومتر ۲۱ بزرگراه لشگری (جاده مخصوص کرج)

روبروی پالایشگاه نفت پارس، پلاک ۱۲

## Sintering Machine



**Belt-type sintering machine The usual specification is 18-360m<sup>2</sup> (effective area for sintering)**



[www.famcocorp.com](http://www.famcocorp.com)

E-mail: [info@famcocorp.com](mailto:info@famcocorp.com)

@famco\_group

Tel: ۰۲۱-۴۸۰۰۰۰۴۹

Fax: ۰۲۱-۴۴۹۹۴۶۴۲

تهران، کیلومتر ۲۱ بزرگراه لشگری (جاده مخصوص کرج)

روبروی پالایشگاه نفت پارس، پلاک ۱۲

## Steel production process --- pellets

The pellet production process is a production process for refining pellets. Pellets are finely ground iron ore concentrates or other iron-containing powders, mixed with a small amount of additives, then rolled into balls by a pelletizer under the condition of adding water and moistened, and then dried and roasted to consolidate to a certain strength And metallurgical properties of spherical iron-containing raw materials.



## Fans that are the main focus of coking

Coke oven blower, coal loading dust removal fan, coke discharge dust removal fan, etc.



www.famcocorp.com

E-mail: info@famcocorp.com

@famco\_group

Tel: ۰۲۱-۴۸۰۰۰۰۴۹

Fax: ۰۲۱-۴۴۹۹۴۶۴۲

تهران، کیلومتر ۲۱ بزرگراه لشگری (جاده مخصوص کرج)

روبروی پالایشگاه نفت پارس، پلاک ۱۲

# High-Voltage inverter application

## Ironmaking blast furnace

**FAMCO**  
هایپر صنعت



www.famcocorp.com

E-mail: info@famcocorp.com

@famco\_group

Tel: ۰۲۱-۴۸۰۰۰۰۴۹

Fax: ۰۲۱-۴۴۹۹۴۶۴۲

تهران، کیلومتر ۲۱ بزرگراه لشگری (جاده مخصوص کرج)

روبروی پالایشگاه نفت پارس، پلاک ۱۲

## Steel production process---steel rolling

Dust removal fan, blower, ring turbidity pump system (including descaling pump), etc.



[www.famcocorp.com](http://www.famcocorp.com)

E-mail: [info@famcocorp.com](mailto:info@famcocorp.com)

@famco\_group

Tel: ۰۲۱-۴۸۰۰۰۰۴۹

Fax: ۰۲۱-۴۴۹۹۴۶۴۲

تهران، کیلومتر ۲۱ بزرگراه لشگری (جاده مخصوص کرج)

روبروی پالایشگاه نفت پارس، پلاک ۱۲

# High-Voltage inverter application

**FAMCO**  
هایپر صنعت



[www.famcocorp.com](http://www.famcocorp.com)

E-mail: [info@famcocorp.com](mailto:info@famcocorp.com)

@famco\_group

Tel: ۰۲۱-۴۸۰۰۰۰۴۹

Fax: ۰۲۱-۴۴۹۹۴۶۴۲

تهران، کیلومتر ۲۱ بزرگراه لشگری (جاده مخصوص کرج)

روبروی پالایشگاه نفت پارس، پلاک ۱۲

## Application of high voltage frequency converter on hoist

### High voltage frequency conversion transformation effect:

- ① Short-circuit the motor rotor winding inside the motor to completely solve the fault point caused by the carbon brush.
- ② The energy feedback braking method is adopted when decelerating, and it is not necessary to decelerate by applying brakes.
- ③ The hoist runs automatically according to the set speed chart during the hoisting time period, and the hoisting time is shortened from 170s to 110s, which improves the efficiency of the hoist.
- ④ Energy saving

When the hoisting winch is hoisting upwards, the motor is in an electric state. Since the hoist is a constant torque load, the ratio of the speed of the hoist is reduced and the ratio of energy saving in place

When the hoisting winch is in the lowering state, the electric motor is in the state of generating electricity, and the potential energy is converted into electric energy, and the frequency converter can adopt energy consumption braking or energy feedback. With energy feedback, electrical energy can be fed back to the grid, and the energy-saving effect is



## Application of High Voltage Frequency Converter in Mine Ventilation

The main fan of the coal mine is one of the four main equipment of the coal mine. The main fan plays an important role in the production of the coal mine. As the main ventilation of the mine, it runs 24 hours a day and is the "breathing" system of the entire mine.

The main fan adopts direct start, the starting current is large, the insulation of the motor has a greater threat, and the motor may even be burned in severe cases.

The degree of automation is low. The main fan fan relies on manual adjustment of the baffle, and does not have the automatic real-time adjustment function of the air volume, and the degree of automation is low.

# High-Voltage inverter application

**FAMCO**  
هایپر صنعت



[www.famcocorp.com](http://www.famcocorp.com)

E-mail: [info@famcocorp.com](mailto:info@famcocorp.com)

@famco\_group

Tel: ۰۲۱-۴۸۰۰۰۰۴۹

Fax: ۰۲۱-۴۴۹۹۴۶۴۲

تهران، کیلومتر ۲۱ بزرگراه لشگری (جاده مخصوص کرج)

روبروی پالایشگاه نفت پارس، پلاک ۱۲

# High-Voltage inverter application

## Application of High Voltage Frequency Converter in Mine Ventilator



**Centrifugal fan**

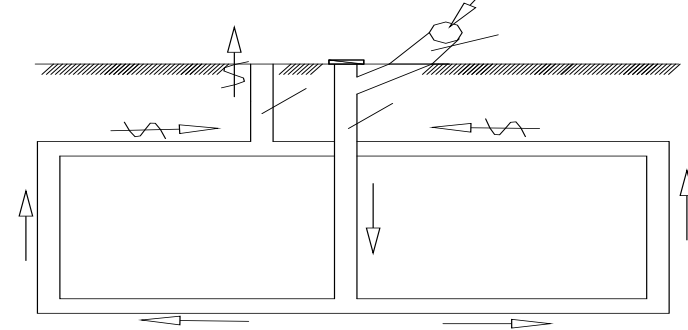

**Press-in**

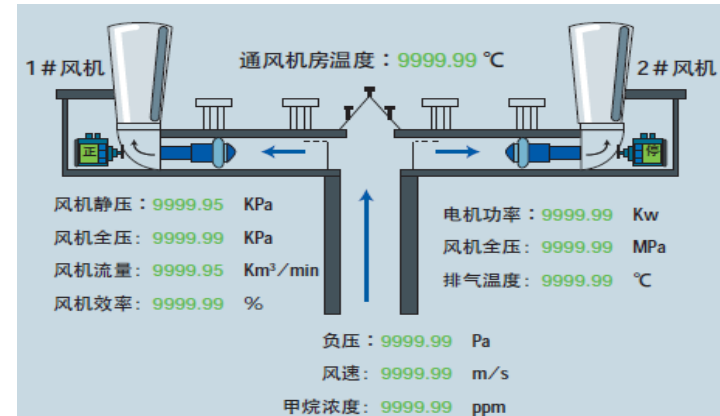

# High-Voltage inverter application

Application of High Voltage Frequency Converter in Mine Ventilato

**FAMCO**  
هایپر صنعت



[www.famcocorp.com](http://www.famcocorp.com)

E-mail: [info@famcocorp.com](mailto:info@famcocorp.com)

[@famco\\_group](https://www.instagram.com/famco_group)

Tel: ۰۲۱-۴۸۰۰۰۰۴۹

Fax: ۰۲۱-۴۴۹۹۴۶۴۲

تهران، کیلومتر ۲۱ بزرگراه لشگری (جاده مخصوص کرج)

روبروی پالایشگاه نفت پارس، پلاک ۱۲

## Application of High Voltage Frequency Converter in Mine Ventilation

After the inverter is reformed, the fan can realize the frequency conversion soft start, avoiding the impact of the starting current, not only has no impact on the power grid, but also can be started or stopped at any time.

After the frequency conversion transformation, most of the working time of the fan runs at a lower speed, thus greatly reducing the mechanical strength and electrical shock of the fan work, which will greatly extend the service life of the fan and reduce the maintenance intensity.

During the operation of the inverter, the one-key anti-wind function can be realized without the operation of the reversing cabinet, which shortens the working time and improves the working efficiency.

It should be noted that after the frequency conversion speed regulation of the counter-rotating fan in the coal mine, the operating frequencies of the two motors are generally required to be as consistent as possible, so as to ensure the same speed of the motors. Avoid a high speed and a low speed, which will cause wind resistance and affect the normal operation of the fan.

## Application of Hitek High-Voltage Frequency inverter in Thermal Power Power Investment Corporation



www.famcocorp.com

E-mail: info@famcocorp.com

@famco\_group

Tel: ۰۲۱-۴۸۰۰۰۰۴۹

Fax: ۰۲۱-۴۴۹۹۴۶۴۲

تهران، کیلومتر ۲۱ بزرگراه لشگری (جاده مخصوص کرج)

روبروی پالایشگاه نفت پارس، پلاک ۱۲

# High-Voltage inverter application

## Application of High-Voltage Frequency Converter in Thermal Power Block Power Investment Corporation



Motor			
Model	YKK5603-6	Speed	1500r/min
Voltage	6kV		

www.famcocorp.com

E-mail: info@famcocorp.com

@famco\_group

Tel: ۰۲۱-۴۸۰۰۰۰۴۹

Fax: ۰۲۱-۴۴۹۹۴۶۴۲

تهران، کیلومتر ۲۱ بزرگراه لشگری (جاده مخصوص کرج)

روبروی پالایشگاه نفت پارس، پلاک ۱۲

## Application of High-Voltage Frequency Converter in Drain Pump

Most of the drainage pumps used in coal mines use valves to change the resistance of the water supply pipeline to adjust the flow.

High-voltage frequency conversion technology is used to adjust the speed of the water pump to adjust the flow rate.

For pump sets with parallel drainage, one high-voltage inverter can be used to control two or three constant pressure variable drainage systems.

Using frequency conversion speed regulation, the maintenance of the entire drainage system is reduced, and the degree of automation is increased, the power saving effect is obvious, and the drainage effect is good.



## Application of High-Voltage Frequency Converter in Circulating Water Pump and Steel.

### 2. Circulating water pump parameters

The relevant parameters of the circulating water pump are as follows:

Motor model: Y4503-2 rated voltage; 10 KV

Pump flow:  $Q=440$  (m<sup>3</sup>/h) rated power; 450 kW

Head:  $H=603$ m Rated current: 31.7A

Rated speed: 2950r/min



[www.famcocorp.com](http://www.famcocorp.com)

E-mail: [info@famcocorp.com](mailto:info@famcocorp.com)

@famco\_group

Tel: ۰۲۱-۴۸۰۰۰۰۴۹

Fax: ۰۲۱-۴۴۹۹۴۶۴۲

تهران، کیلومتر ۲۱ بزرگراه لشگری (جاده مخصوص کرج)

روبروی پالایشگاه نفت پارس، پلاک ۱۲

## 16000KVA/6KV High-Voltage frequency.



 [www.famcocorp.com](http://www.famcocorp.com)

 E-mail: [info@famcocorp.com](mailto:info@famcocorp.com)

 [@famco\\_group](https://www.instagram.com/famco_group)

 Tel: ۰۲۱-۴۸۰۰۰۰۴۹

 Fax: ۰۲۱ - ۴۴۹۹۴۶۴۲

تهران، کیلومتر ۲۱ بزرگراه لشگری (جاده مخصوص کرج)

روبروی پالایشگاه نفت پارس، پلاک ۱۲

# High-Voltage inverter application

## 16000KVA/6KV high voltage frequency converter.



[www.famcocorp.com](http://www.famcocorp.com)

E-mail: [info@famcocorp.com](mailto:info@famcocorp.com)

@famco\_group

Tel: ۰۲۱-۴۸۰۰۰۰۴۹

Fax: ۰۲۱-۴۴۹۹۴۶۴۲

تهران، کیلومتر ۲۱ بزرگراه لشگری (جاده مخصوص کرج)

روبروی پالایشگاه نفت پارس، پلاک ۱۲

## 16000KVA/6KV high voltage frequency converter

**Internal diagram of  
power unit system diagram**



**Water cooling**



[www.famcocorp.com](http://www.famcocorp.com)

E-mail: [info@famcocorp.com](mailto:info@famcocorp.com)

@famco\_group

Tel: ۰۲۱-۴۸۰۰۰۰۴۹

Fax: ۰۲۱-۴۴۹۹۴۶۴۲

تهران، کیلومتر ۲۱ بزرگراه لشگری (جاده مخصوص کرج)

روبروی پالایشگاه نفت پارس، پلاک ۱۲

# High-Voltage inverter application

**FAMCO**  
هایپر صنعت

## On-site application Hitek High-Voltage inverter list

Customer	Field	Voltage	Load power	Quantity	Load Type
Anhui Tenglong Metallurgy	Metallurgical industry	10Kv	560Kw	2	Dust removal fan
Hebei Xingang Steel	Metallurgical industry	10Kv	630Kw	4	Dust removal fan, mixer
Laiwu Iron and Steel Group	Metallurgical industry	10Kv	8700Kw	1	Sintering fan
Inner Mongolia Kangxin Metal	Metallurgical industry	10Kv	3200Kw	1	Sintering fan
Wuhai Shunda Metallurgy	Metallurgical industry	10Kv	1800Kw	5	Blast furnace blower, sintering fan
Tianjin Rongcheng Steel	Metallurgical industry	6KV, 10Kv	250Kw, 710Kw	13	Dust removal fan, blower, exhaust fan
Fushun Aluminum	Metallurgical industry	10Kv	1000Kw	2	Purification fan
Ningxia Jiyuan Metallurgy	Metallurgical industry	10Kv	1600Kw	3	Sintering fan
Jieyang Taidu Steel	Metallurgical industry	10Kv	630Kw	1	Circulating pump
Jiangsu Shagang Group	Metallurgical industry	10Kv	1000Kw	1	Gas blower
Lianfeng Steel	Metallurgical industry	10Kv	1400Kw	3	Secondary fan and water pump
Zhangjiagang Shagang Group	Metallurgical industry	10Kv	2500Kw	1	Fan
Hebei Wenfeng Steel	Metallurgical industry	10Kv	710Kw	2	No. 1 iron factory fan
Shijiazhuang Tianli Metal	Metallurgical industry	10Kv	8500Kw	1	Blast furnace blower
Chongqing Wanzhou Power Plant	Power Industry	10Kv	2400Kw	8	Condensate pump, fan
Ningdian Tou Xixia Thermal Power	Power Industry	6Kv	1400Kw	10	Sintering induced draft fan, condensate pump, blower
Hangzhou South World Super League	Power Industry	6Kv	560Kw	1	Desulfurization booster fan
Wuxi Longjun Electric Power	Power Industry	6Kv	700Kw	2	Primary Fan
Datang Second Power Plant	Power Industry	10Kv	1000Kw	1	Condensation fan
Suzhou Soochow Thermal Power	Power Industry	10Kv	1000Kw	2	Boiler induced draft fan
Datang Weihe Power Generation	Power Industry	6Kv	1400Kw	2	300MW primary wind turbine
Baihe Electric Power Co., Ltd.	Power Industry	6Kv	280Kw	2	25MW blower
Yuanmou Earth Forest Construction	Building Materials Industry	10KV	1000KW	1	Fan
Sichuan New Machinery Foundry	Building Materials Industry	6KV, 10KV	450KW, 1250KW	3	Fan
Liaoning Chaoyang Dongxin Cement	Building Materials Industry	6KV	280KW	6	Exhaust fan, high temperature fan
Asia-Pacific Harbin Cement	Building Materials Industry	10KV	900KW	1	High temperature blower
Guangdong Southern Cement	Building Materials Industry	6KV	450KW	1	ventilator
Tieling Tiexin Cement	Building Materials Industry	10KV	1250KW	1	Fan
Xinjiang Baoming Mining	Mining industry	10KV	250KW	8	Fan
Jieyang City Water Supply Plant	Municipal industry	10KV	630KW	1	Water pump

www.famcocorp.com

E-mail: info@famcocorp.com

@famco\_group

Tel: ۰۲۱-۴۸۰۰۰۰۴۹

Fax: ۰۲۱-۴۴۹۹۴۶۴۲

تهران، کیلومتر ۲۱ بزرگراه لشگری (جاده مخصوص کرج)

روبروی پالایشگاه نفت پارس، پلاک ۱۲

# Part 04

## Service

The user can demonstrate on a projector or computer, or presentation and make it film to be used in a wider field

[www.famcocorp.com](http://www.famcocorp.com)

E-mail: [info@famcocorp.com](mailto:info@famcocorp.com)

@famco\_group

Tel: ۰۲۱-۴۸۰۰۰۰۴۹

Fax: ۰۲۱-۴۴۹۹۴۶۴۲

تهران، کیلومتر ۲۱ بزرگراه لشگری (جاده مخصوص کرج)

روبروی پالایشگاه نفت پارس، پلاک ۱۲

# Full service for you

- Made solutions for your system
- Installation and technical support
- Training
- Preventive maintenance agreement
- Professional and fast after-sales service



## Full service for you

Hitek also offers training services to build knowledge, skills, and competencies to help you maximize the return on your investment.

Options include classroom training in our training facility located at our corporate office, customizable on-site training at your facility, and web-based training.

And last but certainly not least, Professional Service Agreements ensure continued, long-term performance of your watering system and provide you peace of mind that your system will perform as intended. Our technicians understand animal facility operations and work to minimize interruptions in your normal daily procedures.



 [www.famcocorp.com](http://www.famcocorp.com)

 E-mail: [info@famcocorp.com](mailto:info@famcocorp.com)

 [@famco\\_group](https://www.instagram.com/famco_group)

 Tel: ۰۲۱-۴۸۰۰۰۰۴۹

 Fax : ۰۲۱ - ۴۴۹۹۴۶۴۲

تهران ، کیلومتر ۲۱ بزرگراه لشگری (جاده مخصوص کرج)

روبروی پالایشگاه نفت پارس ، پلاک ۱۲