

ELECON
EON Series
Eternal Excellence



Catalogue No.: 209/EECL/06/15

www.elecon.com



WORLD'S MOST TECHNOLOGICALLY ADVANCED GEAR MANUFACTURING FACILITY

BHANUBHAI MEMORIAL CENTRE OF EXCELLENCE (BMCE)

In the last six decades, Elecon have conducted intensive research in gear technology and manufacturing techniques. We have developed a variety of products in the transmission industry from worm gears to helical, from planetary to variable speed fluid couplings. This development has demanded a significant investment in manufacturing capability from gear cutting right through to heat treatment and profile grinding. This new plant has the capacity to manufacture sufficient helical gears to produce 1000 assembled gear units per month.

This plant is a tribute to our founding Chairman, Lt. Shri Bhanubhai Patel, who wanted to remain "Always a step ahead in technology"



Contents

• Characteristic Features & Nomenclature...	1 - 2
• Selection Tables & Example...	3 - 4
• Power Ratings & Thermal Capacity	
♦ S1, S2, S3, S4...	5 - 8
♦ K2, K3, K4...	9 - 11
• Actual Ratios...	12 - 13
• Dimensional and Handing Details....	
♦ S1...	14 - 15
♦ S2...	16 - 21
♦ S3...	22 - 27
♦ S4...	28 - 31
♦ K2...	32 - 39
♦ K3...	40 - 49
♦ K4...	50 - 59
• Output Shaft Types...	60 - 61
• Hollow Shaft with Keyway Details...	62
• Hollow Shaft and Shrink Disk Details...	63 - 64
• Bevel - Intermediate Shaft Extension	65
• Torque Arm Details...	66
• Solid Shaft Extension Details....	67
• Cooling Coil....	68
• Moment of Inertia GD^2	69 - 70

Characteristic and advantages of the EON-SERIES GEAR UNITS

<p>Overview : Keeping in line with it`s strategy of "Always a step ahead in technology" Elecon presents the EON Series -answer to industry needs.</p> <p>The EON series has been developed keeping in mind the industry requirements and offers greater flexibility and advantages and presents a wide range of features :</p> <ul style="list-style-type: none"> • Higher torque ratings. • Foot print same as ET Series. • Suitable for numerous applications. • Various sealing options available. • Different cooling options. <p>General Information and Characteristic Features</p> <p>Technical : The power tables apply to normal conditions, i.e., drive by an electric motor, smooth operation, operation for eight hours per day, 2.5-fold starting torque relative to catalogue performance PN, 100% duration of operation, ambient temperature 20Deg C. Power for intermediate speeds can be interpolated linearly.</p> <p>Higher drive speeds than indicated and selection as finite-fatigue strength gears on request. Reinforced bearings are optional for heavy external forces (e.g. output drive by pinion).</p> <p>Design :</p> <ul style="list-style-type: none"> • Increased torque capacity • Different shaft designs as standard options • Modular concept casings enabling faster deliveries • Different sealing options • Better cost to performance ratio 	<p>Efficiencies : 99 % for single stage helical gear units 98 % for double stage helical gear units 97.5% for triple stage helical gear units 97% for quadruple stage helical gear units 97.5% for double stage bevel helical gear units 97% for triple stage bevel helical gear units 96.5% for quadruple stage bevel helical gear units</p> <p>Mounting : Horizontal & Torque Arm mounting positions.</p> <p>Noise Levels : Allowable noise level is 85 dB. Lower noise levels with additional add-ons can be achieved.</p> <p>Vibration Levels : Allowable vibration limits is generally as per ISO 10816.</p> <p>Thermal Capacities : In-addition to higher torques the EON series comes with optimized thermal ratings which is due to larger available surface area.</p> <p>Installation : Before the gear unit is set up the operating instructions should be studied and followed. The plant user should provide protection covers on rotating parts.</p>	<p>Selection of Gear:</p> <hr/> <p>Single stage Helical Gear S1 $i_N = 1.25$ to 5</p> <hr/> <p>Double stage Helical Gear S2 $i_N = 5.6$ to 22.4</p> <hr/> <p>Triple stage Helical gear S3 $i_N = 20$ to 112</p> <hr/> <p>Quadruple stage Helical gear S4 $i_N = 90$ to 560</p> <hr/> <p>Double stage Bevel Helical Gear K2 $i_N = 5$ to 22.4</p> <hr/> <p>Triple stage Bevel Helical Gear K3 $i_N = 20$ to 100</p> <hr/> <p>Quadruple stage Bevel Helical Gear K4 $i_N = 80$ to 560</p>
---	---	---

Nomenclature:

S 3 - 20 - H N - 1 - A - 0 0 - 0 5 0 0 - 1 1

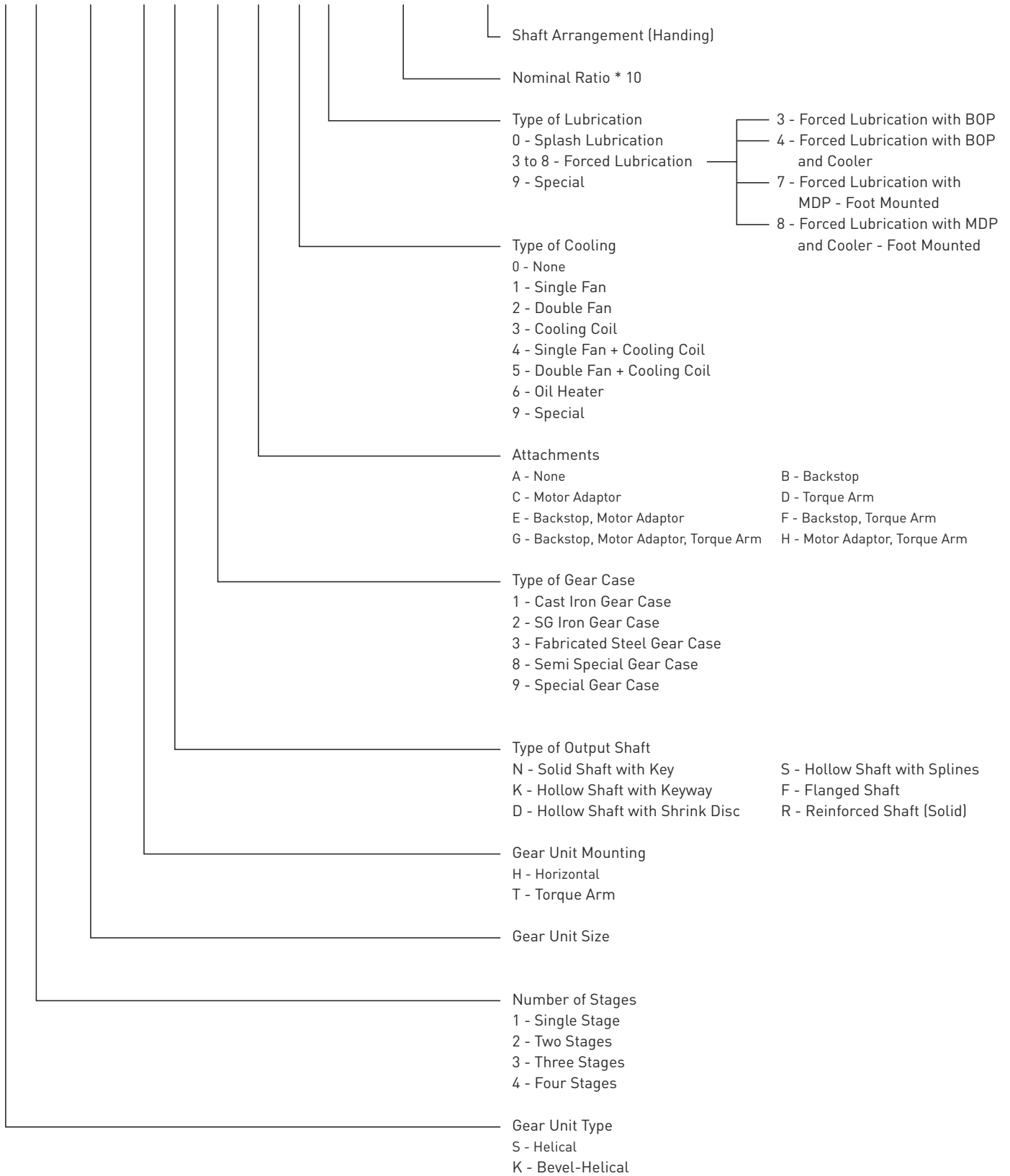

Selection Example and symbolic Designation:

1. Determination of the type of gear
 - 1.1 Establish whether helical gear or bevel helical gear
 - 1.2 Determine the transmission ratio

$$i_N = \frac{n_1}{n_2}$$

The type of gear is then determined
2. Determination of the gear size
 - 2.1 Finding out gear box size

$$P_N \leq P_e \times f \quad f = f_1 \times f_2$$
 - 2.2 Checking starting torque

$$\frac{M_K \cdot n_1}{P_N \cdot 955} \leq 2.5$$
3. Checking Thermal Rating
 - 3.1 Gear unit without additional cooling Possible when

$$P_e \leq P_1 \times f_w$$
 - 3.2 Gear unit with fan Sufficient when

$$P_e \leq P_2 \times f_w$$
 - 3.3 Gear unit with built-in cooling coil Sufficient when

$$P_e \leq P_3 \times f_w$$
 - 3.4 Gear unit with built-in cooling coil and fan required when

$$P_e \leq P_4 \times f_w$$
 - 3.5 Gear unit with external oil cooler necessary when

$$P_e \leq P_4 \times f_w$$

i_N	= nominal transmission ratio
n_1	= input speed [rpm]
n_2	= output speed [rpm]
P_N	= nominal gear box rating [kw] - refer normal power rating table
P_e	= absorbed power of the connected machine [kw]
f	= service factor = $f_1 \times f_2$ (from table 1, 2 and 4)
f_w	= factor for amb. temperatures (Refer table 3)
t	= ambient temperature [$^{\circ}$ C]
E_D	= running period [%], e.g. $E_D = 80\%$
P_1	= Thermal capacity without additional cooling at $t=20^{\circ}$ C; $E_D = 100\%$ (Refer respective thermal capacity table)
P_2	= Thermal capacity with fan at $t=20^{\circ}$ C; $E_D=100\%$
P_3	= Thermal capacity with built-in cooling coil at $t=20^{\circ}$ C; $E_D=100\%$
P_4	= Thermal capacity with built-in cooling coil and fan at $t=20^{\circ}$ C; $E_D=100\%$
M_K	= Starting torque or max. input torque [da Nm]

Example selection of calculation

Given

Prime mover :

Electric Motor, P motor = 500 kw,

$n_1 = 1500$ rpm

2 fold starting torque $M_K = 6370$ Nm

Working Machine

Heavy rubber-belt conveyor

Required output power, $P_e = 450$ kW

Speed, $n_2 = 60$ rpm

Period of operation : 16 hours per day

Starts : 1 per hour

Running duration per hour, $E_D = 100\%$

Ambient temperature : 40° C

Gearbox type : Bevel Helical Gearbox

Selection of gear :

Required : Bevel Helical Gearbox

Design :

1. Determination of the gearbox type

1.1 Bevel helical gear is specified

1.2 $i_N = \frac{n_1}{n_2}$

$$= \frac{1500}{60}$$

$$= 25 : 1$$

Selected: Gearbox type is K3, triple reduction bevel helical gear unit.

2. Determination of gearbox size :

2.1 Operating factor : 'f' from tables 1 and 2 = 1.5

2.2 Required nominal gearbox rating :

$$P_N = P_e \times f \\ = 450 \times 1.5 \\ = 675 \text{ kW}$$

2.3 From power table select K3 gearbox size

26 with $P_N = 701$ kW

2.4 $P_N \geq P_e \times f$, as $701 \text{ kW} \geq 450 \text{ kW} \times 1.5 = 675 \text{ kW}$

2.5 Checking starting torque :

$$\frac{M_K \times n_1}{P_N \times 9550} \leq 2.5 \\ \frac{6370 \times 1500}{701 \times 9550} = 1.43 \leq 2.5$$

3. Checking the thermal capacity :

3.1 From table 3

$f_w = 0.75$ for gear box without additional cooling

$P_e \leq P_1 \times f_w$ as $450 \text{ kW} \leq 247.5 \text{ kW}$ ($330 \text{ kW} \times 0.75$)

i.e. Additional Cooling is required

3.2 From table 3

$f_w = 0.8$ for gear box with fan cooling

$P_e \leq P_2 \times f_w$ as $450 \text{ kW} \leq 537 \text{ kW}$ ($672 \text{ kW} \times 0.8$)

i.e. Gearbox with additional fan cooling

3.3 The selected gear box is K3-26, $i_N = 25:1$ and requires fan cooling.

Operating factors:

Table 1		Load parameters			
Driven machines		Driven machines		Driven machines	
Excavators and stackers		Impeller blowers	G	-- wet	S**
Bucket chain excavators	S*	Turbo blowers	G	-- suction	S**
Travelling gear		Centrifugal blowers	G	Suction rollers	S**
--- caterpillar track	S*	Generators		Drying cylinders	S**
--- rail	M	Generators, under uniform load	G	Pumps	
Bucket-wheel stackers	M*	Welding generators	***	Proportioning pumps	M
Bucket wheels		Rubber and Plastics		Piston pumps	
--- clearing	S	Extruders		- U < 1:100	S
--- coal	S	-- rubber	S**	- U > 1:100 - 1:200	M**
--- lime	S	-- plastics	M**	Centrifugal pumps	
Cutter heads	S*	Calenders	M**	- light liquids	G
Slewing machines	M*	Kneading machines, rubber	S**	- viscous liquids	M
Suction pumps	M*	Mixers	M**	Compression pumps	S
Cable drums	M	Mills, rubber	M**	Plunger pumps	S**
Winches	M	Rolling mills, rubber	S**	Sand pumps	M**
Minning, rock, earth		Wood-working machinery		Machines for the Textile Industry	
Concrete mixers	M	Decorticating drums	S	Bobbins winding machines	M
Crushers	S	Planing machine	M	Printing machines	M
Briquetting presses	H	Saw frames	M	Dyeing machines	M
Rotary kilns	S**	Iron and Steel Industry		Tan-liquor vessels	M
Pneumatic sifters	M*	Foundry crane (hoisting gear)	S**	Calenders	M
Clay mixers	M	Converters	***	Willowing machines	M
Chemical Industry		Slag cars	G**	Drying machines	M
Mixers	M	Sintering belts	M**	Looms	M
Agitators		Crusher	S**	Compressors	
--- pure liquids	G	Torpedo mixers	***	Rotary piston compressors	
--- liquids and solids	M	Car tipper	S	- U < 1:100	S
--- liquids with various densities	M	Cranes		- U > 1:100 - 1:200	M
Rotary Dryer	M	Luffing gear	G*	Centrifugal compressors	M
Centrifuges		Travelling gear	M*	Turbo compressors	M
--- light	G	Hoisting gear	M*	Rolling mills	
--- heavy	M	Slewing gear	M*	Plate tilters	M**
Petroleum Industry		Winches	G	Bloom pushers	H**
Drilling pumps	***	Metal working		Bloom conveying plant	S**
Rotary Kilns	M	Folding presses	S	Wire pulls	M
Filter presses	M**	Plate bending machines	M**	Revolving turrets	M**
Pipeline pumps	M**	Plate straightening presses	S	(contin. casting)	
Scavenging pumps	M**	Eccentric presses	S	De-scaling crushers	S**
Conveying plants		Hammers	S**	Reels	
Uniform load		Planing machines	S	- strip	M*
Bucket conveyors	G	Crank presses	S	- wire	M**
Roasting furnace conveyors	G	Shearing machine	M**	Walking beam conveyors	M**
Assembly line belts	G	Forging presses	S	Chain transporter	M**
Band conveyors	G	Punching machines	S	Cooling troughs	M**
Overhead conveyors	G	Mills		Traverse tractors	M**
Chain conveyors	G	Hammer mills	H**	Pipe welding machine	S
Apron conveyors	G	Edge mills	H**	Pipe drawing machine	S*
Worm conveyors	G	Ball mills	H**	Roller strightening machine	M**
Medium and heavy load		Pendulum mills	H**	Roller gear beds	
Shaft - sinking machines	S*	Impact mills	H**	--- light	M**
Bucket conveyors	M	Tube mills	H**	--- heavy	S**
Bucket belts	M**	Beating mills	H**	Shears	
Assembly line conveyors	M	Rod mills	H**	--- plate	S**
Conveyors winders	M**	Roller mills	H**	--- wire	M**
Conveyors	S*	Foodstuffs machines		--- billet	S**
Belt Conveyors	M	Filling machines	G	--- cropping	S**
Chain Conveyors	M	Kneading machines	M	--- plate trimming	M**
Goods lifts	M	Packing machines	G	Winding turret	M**
Passenger lifts	***	Weighing machines	M	Winding tractor	M**
Apron conveyors	M	Sugarcane crushers	M**	Continuous casting plants	S**
Shaker conveyors	M	Sugarcane mills	S**	Shifting device	S
Worm conveyors	M	Sugarcane Cutters	M**	Roller adjusting device	M
Inclined lifts	S**	Sugar-beet Cutters	M	Water recycling machine	
Blowers, fans, ventilators		Paper machines		Thickeners	M
Axial blowers	M	Couchers	S**	Gyroscopic ventilators	M
Rotary piston blowers	M	Glazing cylinders	S**	Mixers	M
Large ventilators (mining)	M	Calenders	M**	Water screws	M
Cooling tower fans	***	Mixers	M	Vacuum filter presses	M
Radial blowers	M	Presses		Rate/Screen drives	G
Induced draft fans	M	--- glue	S**		

Table 2		Service factor			f ₁	
Prime mover	Hours of operation/day	Prime mover Load parameter			Extra Heavy duty H	2.0 2.25 2.5
		Uniform load G	Medium load M	Heavy load S		
Electric motor	up to 3	0.80	1.00	1.50	2.0	2.25
	over 3 to 10	1.00	1.25	1.75		
turbine	over 10 to 24	1.25	1.50	2.00	2.5	2.75
	up to 3	1.00	1.25	1.75		
Piston engines	over 3 to 10	1.25	1.50	2.00	2.5	2.75
	over 10 to 24	1.50	1.75	2.25		
U>1:100-1:200	up to 3	1.25	1.50	2.00	2.5	2.75
	over 3 to 10	1.50	1.75	2.25		
Piston engines	over 10 to 24	1.75	2.00	2.50	3.0	
	U<1:100					

1) Cooling water temperature max. 20° C
Load parameters
G = Uniform load
M = Medium load
S = Heavy load
H = Extra Heavy duty
* = Detailed calculation on request
** = Only calculated for 24-hour period of operation
*** = Load parameter on request.
U = Cyclic variation

The load parameters quoted are parameters gained from experience. Calculations for driven machines not mentioned above or deviations from the norm obtainable on request.

Table 3		Factor for amb. temperatures					f _w
Type of cooling	Ambient temperature	Duration of operation per hour					
		100%	80%	60%	40%	20%	
For gear boxes without additional cooling	10° C	1.12	1.34	1.57	1.79	2.05	
	20° C	1.0	1.2	1.4	1.6	1.8	
	30° C	0.88	1.06	1.23	1.41	1.58	
	40° C	0.75	0.9	1.05	1.2	1.35	
For gear boxes with fans and cooling coils	50° C	0.63	0.76	0.88	1.01	1.13	
	10° C	1.15	1.38	1.61	1.84	2.07	
	20° C	1.0	1.2	1.4	1.6	1.8	
	30° C	0.9	1.08	1.26	1.44	1.62	
For gear boxes with fans and cooling coils	40° C	0.8	0.96	1.12	1.29	1.44	
	50° C	0.7	0.84	0.98	1.12	1.26	
	10° C	1.1	1.32	1.54	1.76	1.98	
	20° C	1.0	1.2	1.4	1.6	1.8	
For gear boxes with fans and cooling coils	30° C	0.9	1.08	1.26	1.44	1.62	
	40° C	0.85	1.02	1.19	1.36	1.53	
	50° C	0.8	0.96	1.12	1.29	1.44	
	10° C	1.12	1.34	1.57	1.79	2.05	
For gear boxes with fans and cooling coils	20° C	1.0	1.2	1.4	1.6	1.8	
	30° C	0.92	1.1	1.29	1.47	1.66	
	40° C	0.83	1.0	1.16	1.33	1.5	
	50° C	0.78	0.94	1.09	1.25	1.4	

1) Maximum cooling-water temperature 20° C

Table 4		Starting-frequency factor						f ₂
Starts per hour	Service Factor (f ₁)							
		‡	‡	‡	‡	‡	‡	
		1.0	1.2	1.4	1.6	1.8	2.0	
1		1	1	1	1	1	1	
2 to 20		1.2	1.1	1.08	1.07	1.07	1.06	
21 to 40		1.3	1.2	1.17	1.16	1.15	1.08	
41 to 80		1.5	1.4	1.25	1.23	1.18	1.10	
81 to 160		1.6	1.5	1.35	1.3	1.2	1.1	
160 to 320		2	1.8	1.7	1.6	1.5	1.4	
Over 320		2.5	2.25	2	1.9	1.8	1.75	

Nominal Power Rating (kW)

Helical - Single Stage

Type - S1

i _N	n1	n2	Gear unit Size											
			11	13	15	17	18	20	21	22	23	24	25	26
1.25	1500	1200.0	84	171	319	579	723	1376*	2015*	2573*				
	1000	800.0	56	114	213	386	482	917	1343	1716				
	750	600.0	42	86	160	290	361	688	1007	1287				
1.4	1500	1071.4	75	153	285	517	645	1228*	1799*	2298*				
	1000	714.3	50	102	190	345	430	819	1199	1532				
	750	535.7	37	76	142	259	323	614	899	1149				
1.6	1500	937.5	63	121	213	381	488	925	1375*	1875*	2563*			
	1000	625.0	45	89	163	288	363	688	1000	1375	1813	2625	3488*	
	750	468.8	35	70	131	238	300	569	825	1125	1475	1950	2850	
1.8	1500	833.3	56	114	200	363	444	863	1250	1750*	2500*			
	1000	555.6	40	83	150	275	331	650	938	938	1750	2250	3275*	4825*
	750	416.7	31	65	123	225	275	531	763	763	1400	1813	2675	3938
2	1500	750.0	48	99	188	338	425	788	1188	1625*	2250*			
	1000	500.0	34	71	138	250	313	594	875	1175	1625	2100	3125	4538*
	750	375.0	26	55	111	206	263	488	725	963	1275	1713	2488	3713
2.24	1500	669.6	46	85	169	313	388	750	1113	1500*	2063*			
	1000	446.4	33	60	125	238	294	563	813	1125	1500	2000	2875	4200*
	750	334.8	25	46	103	194	238	463	663	925	1213	1575	2275	3438
2.5	1500	600.0	38	71	156	288	363	688	1025	1375	1875*	2563*		
	1000	400.0	26	51	119	213	275	513	775	1025	1400	1813	2625	3850*
	750	300.0	21	40	96	175	225	419	625	838	1125	1475	2150	3150
2.8	1500	535.7	34	60	144	263	331	619	938	1250	1688	2313*		
	1000	357.1	24	43	100	200	250	469	700	938	1250	1638	2388	3613
	750	267.9	19	34	78	163	206	381	575	763	1025	1338	1950	2950
3.15	1500	476.2	29	59	114	238	300	575	850	1150	1563	2063	2900*	4375*
	1000	317.5	20	41	78	175	225	438	638	863	1150	1500	2188	3300
	750	238.1	16	33	59	138	188	356	513	713	938	1200	1788	2688
3.55	1500	422.5	25	54	115	231	300	575	850	1150	1550	1888	2750	4038*
	1000	281.7	18	39	79	163	225	438	613	788	1125	1425	2075	3038
	750	211.3	14	30	59	125	188	344	475	688	888	1163	1688	2488
4	1500	375.0	21	44	94	200	256	575	800	1063	1538	1688	2488	3663
	1000	250.0	14	31	66	131	175	438	569	750	1100	1275	1875	2750
	750	187.5	11	24	50	101	138	331	444	613	838	1038	1525	2329
4.5	1500	333.3	18	39	68	171	244	469	675	975	1388	1550	2213	3200
	1000	222.2	12	28	49	115	175	319	475	710	983	1175	1538	2238
	750	166.7	9.0	21	38	87	131	244	369	534	740	963	1188	1750
5	1500	300.0	15	34	63	146	175	451	594	838	1164	1388	2075	3088
	1000	200.0	10	24	45	98	123	304	425	594	780	1050	1563	2188
	750	150.0	7.9	19	35	74	96	229	325	450	587	863	1275	1688

Thermal Capacity (kW)

*Requires forced feed lubrication.

Nominal Transmission Ratio i _N	n1	Gear unit Size											
		11	13	15	17	18	20	21	22	23	24	25	26
Thermal Capacity P ₁ (kW) for gear unit without cooling													
1.25 to 2.8	1500	29	46	74	115	144	219	281	350	444	550	675	860
	1000	26	43	68	109	140	209	273	344	438	538	663	810
	750	25	40	64	101	129	200	264	338	431	538	663	810
3.15 to 5	1500	23	39	64	103	128	200	275	338	431	550	700	863
	1000	20	36	56	99	118	189	263	325	419	531	669	813
	750	18	28	50	98	108	175	250	300	400	519	656	800
Thermal Capacity P ₂ (kW) for gear unit with fan cooling													
1.25 to 2.8	1500	53	81	128	198	250	388	500	625	800	1075	1340	
	1000	44	69	106	165	225	350	406	528	700	863	1075	
	750	38	63	94	150	206	325	388	488	656	788	1013	1280
3.15 to 5	1500	48	75	115	190	238	375	473	594	769	981	1225	1556
	1000	35	54	94	153	188	300	400	519	656	856	1044	1313
	750	30	46	81	138	169	300	356	450	594	756	956	1250
Thermal Capacity P ₃ (kW) for gear unit with cooling coil													
1.25 to 5	1500	126	180	265	361	419	588	694	813	956	1155	1338	1420
	1000	120	176	255	356	415	571	679	804	950	1138	1338	1420
	750	119	175	245	339	410	563	670	800	938	1113	1325	1390
Thermal Capacity P ₄ (kW) for gear unit with fan and cooling coil													
1.25 to 5	1500	145	215	326	472	569	836	1033	1251	1540	1810	2161	2450
	1000	133	201	300	441	546	791	950	1173	1461	1785	2161	2450
	750	127	194	282	413	522	761	925	1138	1418	1706	2100	2325

Type - S2

Helical - Double Stage

Nominal Power Rating (kW)

i _N	n1	n2	Gear unit Size												
			14	15	16	17	18	19	20	21	22	23	24	25	26
5.6	1500	267.9	54	77	112	136	226	318	461	617	829	982*	1547*	2319*	3230*
	1000	178.6	36	52	75	91	151	212	308	411	553	748	1112	1546	2153
	750	133.9	27	39	56	68	113	159	231	308	415	603	834	1159	1615
6.3	1500	238.1	45	65	85	123	189	256	371	481	663	898*	1378*	1813*	2525*
	1000	158.7	30	44	57	82	130	181	280	364	500	681	1000	1375	1973
	750	119.0	23	31	43	62	93	138	214	288	388	553	750	1125	1484
7.1	1500	211.3	44	62	76	109	182	244	364	475	613	841	1287*	1688*	2470*
	1000	140.8	29	42	51	72	121	169	246	332	456	624	900	1250	1769
	750	105.6	22	30	38	54	89	125	185	263	344	469	688	988	1330
8	1500	187.5	38	57	70	96	163	234	332	438	585	766	1150	1625*	2275*
	1000	125.0	26	39	46	64	111	156	223	319	419	544	850	1188	1607
	750	93.8	19	28	35	48	85	120	168	238	313	408	650	888	1208
9	1500	166.7	35	52	62	85	163	231	293	400	563	707	1025	1375	1950*
	1000	111.1	24	35	42	57	108	156	203	269	375	507	775	1000	1426
	750	83.3	18	25	31	43	84	119	153	213	305	380	625	813	1071
10	1500	150.0	30	46	56	78	130	188	263	364	488	654	950	1313	1846*
	1000	100.0	20	31	37	52	88	124	175	244	331	437	675	938	1275
	750	75.0	15	23	28	39	63	100	132	194	268	328	525	750	958
11.2	1500	133.9	28	42	49	71	124	175	234	325	429	610	850	1125	1625
	1000	89.3	19	27	33	48	85	119	162	219	306	408	625	850	1131
	750	67.0	14	20	25	36	61	90	122	163	231	306	500	625	849
12.5	1500	120.0	25	38	44	62	104	143	214	293	416	532	800	1063	1526
	1000	80.0	17	25	29	41	68	100	143	206	286	355	563	750	1021
	750	60.0	13	19	22	31	53	73	107	156	206	267	413	563	767
14	1500	107.1	22	34	40	54	88	130	195	267	364	459	688	888	1235
	1000	71.4	15	22	26	36	60	91	131	189	254	306	500	650	903
	750	53.6	11	16	20	27	44	65	98	138	181	230	363	525	678
16	1500	93.8	19	29	36	49	78	117	169	241	325	407	613	813	1118
	1000	62.5	13	20	24	33	52	78	115	163	219	272	438	613	776
	750	46.9	9.8	14	18	25	40	59	86	118	163	204	338	463	583
18	1500	83.3	17	25	32	43	72	95	150	182	286	361	538	715	962
	1000	55.6	11	18	21	29	49	66	100	122	189	241	396	513	702
	750	41.7	8.3	13	16	22	38	50	80	96	138	181	313	425	530
20	1500	75.0	15		28	40		95	138		242	324		650	910
	1000	50.0	10		19	27		64	93		161	216		475	629
	750	37.5	7.7		14	20		48	73		121	162		388	472
22.4	1500	67.0	14		26	35		85	124		231	291		613	850
	1000	44.6	9.0		18	24		55	83		156	194		438	567
	750	33.5	6.7		14	18		43	65		124	146		364	426

*Requires forced feed lubrication.

Thermal Capacity (kW)

Nominal Transmission Ration i _N	n1	Gear unit Size												
		14	15	16	17	18	19	20	21	22	23	24	25	26
Thermal Capacity P₁ (kW) for gear unit without cooling														
5.6 to 14	1500	37	52	59	72	104	126	159	207	258	278	386	489	606
	1000	32	46	57	63	94	114	157	197	240	293	360	481	612
	750	29	40	48	60	84	113	139	178	225	298	353	518	601
16 to 22.4	1500	32	44	50	64	81	104	133	178	231	240	337	439	548
	1000	28	38	43	55	80	105	135	166	219	266	350	466	551
	750	25	31	39	47	70	94	125	148	203	247	344	449	513
Thermal Capacity P₂ (kW) for gear unit with fan cooling														
5.6 to 14	1500	60	84	95	116	167	202	256	333	416	448	621	788	976
	1000	49	69	85	95	141	172	236	297	362	442	544	727	924
	750	40	56	67	85	118	158	195	250	315	418	494	725	842
16 to 22.4	1500	54	74	83	107	135	173	221	295	383	399	559	728	909
	1000	43	57	65	83	120	158	203	250	330	402	529	703	832
	750	34	44	55	66	98	132	175	207	284	346	482	628	718
Thermal Capacity P₃ (kW) for gear unit with cooling coil														
5.6 to 22.4	1500	184	215	228	236	292	311	349	394	435	443	695	853	1048
	1000	169	203	222	224	282	294	339	380	429	464	546	659	859
	750	152	175	193	215	260	288	316	354	412	480	526	713	834
Thermal Capacity P₄ (kW) for gear unit with fan and cooling coil														
5.6 to 22.4	1500	203	252	275	306	405	460	550	672	799	842	1225	1534	1893
	1000	181	228	262	276	372	418	527	629	743	864	1044	1344	1724
	750	159	195	222	259	333	402	468	563	685	861	988	1408	1639

Nominal Power Rating (kW)

Helical - Triple Stage

Type - S3

i _N	n1	n2	Gear unit Size											
			15	16	17	18	19	20	21	22	23	24	25	26
20	1500	75.0	21			74			181			481		
	1000	50.0	14.6			49			123			363		
	750	37.5	10.8			38			96			300		
22.4	1500	67.0	20.8			65			163			438		
	1000	44.6	13.8			44			114			331		
	750	33.5	10.3			33			86			269		
25	1500	60.0	17.7	24	33	55	78	104	150	208	257	413	563	754*
	1000	40.0	11.6	16	21	38	53	71	104	143	171	319	394	506
	750	30.0	8.7	12	15	28	39	54	75	109	129	244	300	378
28	1500	53.6	16	21	29	50	70	94	131	181	231	388	506	680*
	1000	35.7	10.5	14	18	34	48	68	90	128	154	288	356	454
	750	26.8	7.8	11	14	25	35	51	68	96	115	206	269	341
31.5	1500	47.6	14	19	25	41	60	89	119	163	205	363	481	601*
	1000	31.7	9.5	13	17	28	41	59	79	109	137	250	319	401
	750	23.8	7.1	9.4	13	21	31	43	61	81	103	188	238	301
35.5	1500	43.3	12	17	23	40	58	77	109	154	185	350	431	543
	1000	28.2	8.4	11	15	28	38	52	73	103	124	231	288	362
	750	21.1	6.3	8.4	11	20	29	39	54	77	93	175	219	272
40	1500	37.5	11	15	21	38	54	70	98	136	166	300	388	484
	1000	25.0	7.4	9.9	15	26	35	47	65	91	111	206	256	323
	750	18.8	5.5	7.4	10	19	28	35	51	68	83	156	194	242
45	1500	33.3	10	13	18	33	45	63	86	122	149	275	344	436
	1000	22.2	6.7	8.8	13	21	31	42	58	82	100	188	225	291
	750	16.7	5	6.6	8.6	16	23	31	45	61	75	144	175	218
50	1500	30.0	8.8	12	15	29	40	56	78	112	130	250	306	380
	1000	20.0	5.9	7.9	11	20	28	37	54	75	87	169	206	254
	750	15.0	4.4	5.9	8.0	15	20	28	40	56	65	125	150	190
56	1500	26.8	8	11	14	25	35	49	69	99	117	219	275	339
	1000	17.9	5.3	7.1	9.6	18	24	34	48	66	78	150	181	226
	750	13.4	4	5.3	7.0	13	19	26	35	50	59	114	138	169
63	1500	23.8	6.9	9.4	12	21	30	44	59	82	105	188	244	306
	1000	15.9	4.5	6.3	7.6	14	20	30	39	54	70	131	163	204
	750	11.9	3.4	4.7	6.1	11	15	23	29	40	53	98	123	153
71	1500	21.1	6.6	8.4	10	19	26	40	52	73	99	169	219	270
	1000	14.1	4.3	5.6	7.1	13	18	27	35	49	66	115	144	180
	750	10.6	3.2	4.2	5.4	9.4	14	20	25	36	50	86	108	135
80	1500	18.8	5.4	7.4	9.1	18	24	36	45	69	88	150	194	258
	1000	12.5	3.6	5.0	6.5	11	16	24	30	43	59	103	125	172
	750	9.4	2.7	3.7	4.9	8.8	13	18	24	34	44	79	95	129
90	1500	16.7		6.6	8.5		21	32		58	79		175	230
	1000	11.1		4.4	5.9		14	22		39	53		115	153
	750	8.3		3.3	4.3		11	16		31	39		86	115
100	1500	15.0		5.9	8.5		21	28		55	71		168	207
	1000	10.0		4.0	5.9		14	19		37	47		112	138
	750	7.5		3.0	4.3		10	14		28	35		84	104
112	1500	13.4		5.3	7.4		19	26		48	62		144	183
	1000	8.9		3.5	5.1		12	17		32	41		94	122
	750	6.7		2.7	3.6		9.3	13		24	31		73	91

*Requires forced feed lubrication.

Thermal Capacity (kW)

Nominal Transmission Ration i _N	n1	Gear unit Size											
		15	16	17	18	19	20	21	22	23	24	25	26
Thermal Capacity P ₁ (kW) for gear unit without cooling													
20 to 35.5	1500	30	40	50	68	99	112	141	187	248	248	285	340
	1000	25	36	42	62	88	104	137	177	231	244	265	320
	750	22	30	38	54	78	92	119	154	217	227	242	305
40 to 112	1500	25	33	44	67	94	109	128	175	229	300	328	335
	1000	22	28	39	64	83	99	127	168	208	307	310	327
	750	20	28	34	53	77	86	115	140	177	279	295	318
Thermal Capacity P ₂ (kW) for gear unit with fan cooling													
20 to 35.5	1500	60	67	86	114	161	183	230	279	393	369	440	540
	1000	58	61	73	103	143	170	225	264	366	363	418	478
	750	50	56	67	95	130	156	197	244	339	339	399	447
40 to 112	1500	60	67	81	118	162	182	215	275	367	402	425	506
	1000	50	56	71	111	151	173	221	265	330	385	405	481
	750	45	54	63	96	142	150	206	241	298	365	385	451
Thermal Capacity P ₃ (kW) for gear unit with cooling coil													
20 to 112	1500	90	95	113	147	187	208	266	313	422	402	450	550
	1000	85	87	96	132	167	193	260	297	393	396	435	540
	750	70	72	85	116	148	171	224	259	368	368	425	520
Thermal Capacity P ₄ (kW) for gear unit with fan and cooling coil													
20 to 112	1500	110	125	154	204	278	312	395	483	659	631	700	834
	1000	100	114	131	184	247	289	386	458	614	622	650	815
	750	90	98	118	164	221	260	335	407	573	579	600	773

Type - S4

Helical - Quadruple Stage

Nominal Power Rating (kW)

i _N	n1	n2	Gear unit Size								
			18	19	20	21	22	23	24	25	26
90	1500	16.7	17			45			138		
	1000	11.1	11			30			92		
	750	8.3	8.3			23			69		
100	1500	15.0	15			41			125		
	1000	10.0	9.9			27			83		
	750	7.5	7.4			20			62		
112	1500	13.4	13			36			114		
	1000	8.9	8.8			25			74		
	750	6.7	6.6			19			54		
125	1500	12.0	12	19	21	33	43	55	101	121	152
	1000	8.0	7.9	13	14	21	28	37	66	80	101
	750	6.0	5.9	9.5	11	16	21	28	50	60	76
140	1500	10.7	11	17	21	29	38	54	90	109	133
	1000	7.1	7.1	11	14	20	25	36	59	71	89
	750	5.4	5.3	8.3	10	15	19	27	45	55	66
160	1500	9.4	9.3	15	18	25	34	49	79	95	121
	1000	6.3	6.2	9.8	12	18	23	33	53	64	81
	750	4.7	4.6	7.4	9.0	13	17	24	40	49	61
180	1500	8.3	8.3	12	15	24	31	39	71	86	100
	1000	5.6	5.5	8.0	9.8	15	21	26	48	58	68
	750	4.2	4.1	6.0	7.3	12	16	19	36	44	51
200	1500	7.5	7.4	11	13	19	28	34	64	78	92
	1000	5.0	5.0	7.1	8.9	13	18	23	43	51	61
	750	3.8	3.7	5.3	6.7	10	14	17	26	38	44
224	1500	6.7	6.6	8.7	12	18	24	30	56	69	82
	1000	4.4	4.4	5.8	8.0	11	17	20	38	46	54
	750	3.3	3.3	4.3	6.0	8.8	12	15	29	28	41
250	1500	6.0	5.9	8.5	10	15	22	27	50	60	71
	1000	4.0	4.0	5.6	7.0	11	15	18	34	40	48
	750	3.0	3.0	4.2	5.2	8.1	11	14	25	30	36
280	1500	5.4	5.3	7.4	9.5	14	19	25	45	55	65
	1000	3.6	3.5	5.0	6.4	9.4	13	16	30	36	43
	750	2.7	2.7	3.7	4.8	6.9	9.7	12	23	28	32
315	1500	4.8	4.7	6.1	8.4	12	16	22	40	49	58
	1000	3.2	3.1	4.1	5.6	8.1	12	15	26	31	37
	750	2.4	2.4	3.0	4.2	6.3	8.8	11	20	25	29
355	1500	4.2	4.2	4.8	7.3	11	16	20	36	44	51
	1000	2.8	2.8	3.2	4.9	7.5	10	13	24	29	34
	750	2.1	2.1	2.4	3.7	5.6	7.8	9.9	18	21	25
400	1500	3.8	3.7	4.9	6.7	10	14	18	33	39	45
	1000	2.5	2.5	3.3	4.5	6.3	9.4	12	21	25	30
	750	1.9	1.9	2.5	3.3	5.0	7.0	8.9	13	19	23
450	1500	3.3	3.3	3.9	6.3	9.4	12	16	26	36	46
	1000	2.2	2.2	2.6	4.2	6.3	8.3	10	18	24	31
	750	1.7	1.7	1.9	3.2	4.4	6.2	7.8	14	18	21
500	1500	3.0		4.8	5.7		11	14		32	37
	1000	2.0		3.2	3.8		7.5	9.4		22	25
	750	1.5		2.4	2.8		5.6	7.0		16	20
560	1500	2.7		4.0	4.9		10	13		28	33
	1000	1.8		2.6	3.3		6.6	8.4		19	22
	750	1.3		2.0	2.5		5.0	6.3		15	17

Thermal Capacity (kW)

Nominal Transmission Ration i _N	n1	Gear unit Size								
		18	19	20	21	22	23	24	25	26
Thermal Capacity P ₁ (kW) for gear unit without cooling										
90 to 560	1500	25	40	46	65	82	107	139	161	190
	1000	23	37	40	54	73	87	124	143	164
	750	20	32	35	54	68	72	113	139	161

Nominal Power Rating (kW) Bevel Helical - Double Stage Type - K2

i _N	n1	n2	Gear unit Size											
			11	13	15	17	18	20	21	22	23	24	25	26
5	1500	300			63		166		544			988*		
	1000	200			53		111		366			738*		
	750	150			39		84		275			613		
5.6	1500	268		26	59		164		543	545		988*	1787*	
	1000	179		18	47		111		365	366		738*	1207*	
	750	134		13	36		84		275	276		613	911	
6.3	1500	238	15	26	56	94	144	297	440	544	763*	988*	1613*	1850*
	1000	159	10	17	43	70	108	200	338	366	581	738*	1205*	1380*
	750	119	7.5	13	30	56	84	151	263	275	475	613	910	1030
7.1	1500	211	15	26	56	94	144	281	431	544	763*	988*	1475*	1793*
	1000	141	10	17	40	70	108	200	331	366	581	738*	1113*	1310*
	750	106	7.5	13	30	56	83	150	250	275	475	613	900	1030
8	1500	188	11	24	50	81	144	256	400	543	763*	938*	1350*	1792*
	1000	125	7.1	16	34	56	108	194	306	366	581	700*	1013*	1260*
	750	94	5.3	13	25	42	69	150	231	275	425	581	825	950
9	1500	167	9.2	23	45	80	125	238	363	494	675*	813*	1225*	1789*
	1000	111	6.2	15	30	53	95	181	275	357	494	638*	925*	1207*
	750	83	4.6	12	24	40	64	149	219	268	371	525	750	910
10	1500	150	8.0	20	40	74	115	206	319	431	586*	763*	1138*	1713*
	1000	100	5.4	14	28	49	78	152	244	319	392	581	775*	1188*
	750	75	4.1	10	21	37	58	115	194	239	295	475	638	888
11.2	1500	134	7.4	16	36	59	101	183	294	389	526*	700*	1050*	1500*
	1000	89	5.0	11	25	40	76	130	219	261	352	538	788	1009*
	750	67	3.8	8.0	19	31	51	98	175	196	264	438	588	758
12.5	1500	120	6.5	16	33	56	94	175	263	356	488	625*	950*	1225*
	1000	80	4.4	10	23	37	70	131	181	257	331	475	600	825
	750	60	3.1	7.8	16	28	45	95	138	188	238	338	456	625
14	1500	107	5.7	13	29	53	71	156	225	325	422	581	725*	975*
	1000	71	3.8	8.1	19	35	47	105	138	206	256	388	519	650
	750	54	2.9	6.1	14	27	35	75	100	144	181	294	388	500
16	1500	94	5.2	9.4	23	42	64	131	169	225	325	513	600	750*
	1000	63	3.5	6.3	14	28	40	79	101	151	188	313	438	513
	750	47	2.6	4.6	11	21	29	58	74	110	138	225	325	381
18	1500	83	4.1	7.5	16	33	58	114	151	225	282	439	578	720
	1000	56	2.8	4.9	11	22	39	76	101	150	188	293	385	480
	750	42	2.0	3.6	8.1	16	29	57	76	112	141	219	289	360
20	1500	75	3.8	7.0		33		103		225	254		520	648
	1000	50	2.5	4.7		22		68		149	169		347	432
	750	38	1.9	3.5		16		51		111	127		260	324
22.4	1500	67	3.5			29		92			227			579
	1000	45	2.4			19		60			151			386
	750	33	1.8			14		45			113			289

*Requires forced feed lubrication.

Thermal Capacity (kW)

Nominal Transmission Ration i _N	n1	Gear unit Size											
		11	13	15	17	18	20	21	22	23	24	25	26
Thermal Capacity P ₁ (kW) for gear unit without cooling													
5 to 11.2	1500	14	23	39	50	82	155	172	201	275	346	400	426
	1000	13	22	36	48	77	122	169	176	262	339	380	414
	750	11	20	32	46	69	108	163	154	257	325	360	412
12.5 to 22.4	1500	12	22	35	51	78	138	168	207	268	331	390	527
	1000	10	20	31	47	67	131	156	190	255	323	370	520
	750	8	18	29	43	63	125	150	188	249	317	350	513
Thermal Capacity P ₂ (kW) for gear unit with fan cooling													
5 to 11.2	1500	36	48	84	104	185	323	387	427	588	704	810	841
	1000	33	46	78	101	175	255	381	372	560	691	750	818
	750	28	40	69	95	148	212	326	299	500	624	700	774
12.5 to 22.4	1500	30	50	85	111	176	289	386	463	599	750	780	830
	1000	24	44	73	96	149	250	324	380	535	646	750	770
	750	20	41	67	87	139	239	312	375	523	635	700	750
Thermal Capacity P ₃ (kW) for gear unit with cooling coil													
5 to 22.4	1500	25	35	70	90	139	210	257	308	412	534	731	752
	1000	20	29	60	101	145	197	307	290	513	685	851	947
	750	20	35	69	90	140	204	251	333	392	522	732	908
Thermal Capacity P ₄ (kW) for gear unit with fan and cooling coil													
5 to 22.4	1500	37	53	97	122	203	344	408	468	637	792	900	1009
	1000	33	48	87	125	198	287	429	419	668	858	880	1089
	750	29	47	85	115	178	262	369	393	575	736	800	1047

type - J

Bevel Helical - Triple Stage

Nominal Power Rating (kW)

i _N	n1	n2	Gear unit Size																	
			14	15	16	17	18	19	20	21	22	23	24	25	26					
20	1500	75.00		21				66						169				538*		
	1000	50.00		15				45						119				394		
	750	37.50		11				35						94				306		
22.4	1500	66.96		19	28			63	81					163	219*			500*	638*	
	1000	44.64		14	19			43	60					113	163			363	450	
	750	33.48		10	14			31	45					88	119			275	344	
25	1500	60.00	11	18	25	32	55	78	104	144	200*	259*	438*	563*	701*					
	1000	40.00	8.0	12	17	21	38	53	69	100	138	173	319	394	468*					
	750	30.00	5.9	8.8	13	16	29	40	52	75	106	130	244	300	351					
28	1500	53.57	10	14	23	28	46	60	93	115	175*	233*	400	506*	625*					
	1000	35.71	6.9	10	15	19	31	43	62	83	118	155	281	356	420*					
	750	26.79	5.1	7.5	11	14	24	33	47	63	89	117	213	269	315					
31.5	1500	47.62	8.8	13	16	25	41	55	86	106	150*	209*	363	481*	564*					
	1000	31.75	6.0	8.8	11	17	28	39	58	74	104	140	250	319	377*					
	750	23.81	4.5	6.9	8.2	13	21	29	43	55	78	105	188	238	283					
35.5	1500	43.25	8.1	12	18	22	38	50	74	96	138	186*	325	431	500*					
	1000	28.17	5.4	8.1	12	15	25	35	49	66	94	124	225	288	340*					
	750	21.13	4.0	6.0	9.1	11	19	26	37	50	70	93	169	219	250					
40	1500	37.50	7.5	11	16	20	34	45	65	86	123	162	294	388	450*					
	1000	25.00	4.9	6.9	11	13	23	31	43	59	84	120	200	269	330					
	750	18.75	3.6	5.5	8.0	10	18	24	32	45	65	82	156	194	230					
45	1500	33.33	6.3	9.4	12	18	30	41	63	80	113	146	269	344	400*					
	1000	22.22	4.4	6.3	8.0	12	20	28	41	53	75	97	181	225	265					
	750	16.67	3.4	5.0	6.0	8.8	15	22	33	40	58	74	138	175	205					
50	1500	30.00	5.8	8.8	13	16	26	38	53	71	100	130	244	306	360*					
	1000	20.00	3.9	5.8	8.7	10	18	25	36	48	68	87	163	206	240					
	750	15.00	3.0	4.4	6.6	7.9	14	19	27	36	51	65	124	150	180					
56	1500	26.79	5.1	7.5	12	14	24	33	47	63	89	117	213	275	320					
	1000	17.86	3.5	5.3	7.7	9.5	16	23	31	43	61	78	144	181	215					
	750	13.39	2.6	3.9	5.7	7.1	13	18	23	33	46	59	110	138	165					
63	1500	23.81	4.6	6.9	8.5	13	21	29	44	55	79	105	188	244	285					
	1000	15.87	3.1	4.6	5.5	8.4	15	21	30	38	54	70	131	163	190					
	750	11.90	2.4	3.5	4.2	6.4	11	16	23	29	40	52	98	123	145					
71	1500	21.13	4.0	6.0	9.1	11	19	26	37	50	70	93	169	219	250					
	1000	14.08	2.8	4.1	6.1	7.5	13	18	25	34	46	62	101	144	166					
	750	10.56	2.1	3.1	4.6	5.6	9.4	15	19	25	34	47	74	108	125					
80	1500	18.75	2.9		7.5	10		24	32		69	81		200	218					
	1000	12.50	2.5		5.3	6.7		17	22		46	54		135	146					
	750	9.38	1.9		3.9	5.0		13	16		34	41		101	110					
90	1500	16.67	2.9		5.7	8.9		22	33		58	73		176	197					
	1000	11.11	1.9		3.8	5.9		15	21		36	49		117	131					
	750	8.33	1.4		2.9	4.4		11	16		26	36		85	99					
100	1500	15.00	2.7			7.9			26			63			174					
	1000	10.00	1.8			5.2			16			39			106					
	750	7.50	1.3			3.9			12			29			78					

*Requires forced feed lubrication.

Thermal Capacity (kW)

Nominal Transmission Ratio i _N	n1	Gear unit Size												
		14	15	16	17	18	19	20	21	22	23	24	25	26
Thermal Capacity P₁ (kW) for gear unit without cooling														
20 to 35.5	1500	26	33	42	44	64	81	106	128	166	195	254	315	330
	1000	23	29	36	40	61	75	95	125	150	166	239	280	295
	750	21	25	33	36	56	69	87	119	148	158	229	260	285
40 to 100	1500	23	30	40	45	60	75	87	120	154	159	239	285	300
	1000	21	26	31	43	58	71	78	118	144	150	226	260	277
	750	19	24	30	38	53	68	78	115	138	140	213	240	265
Thermal Capacity P₂ (kW) for gear unit with fan cooling														
20 to 35.5	1500	66	85	109	111	150	183	237	269	360	425	542	617	672
	1000	59	75	95	100	143	169	213	263	325	363	510	586	601
	750	58	73	90	95	138	156	193	237	288	313	451	527	535
40 to 100	1500	59	75	101	112	144	175	208	265	319	325	488	600	620
	1000	56	70	82	104	135	163	174	244	300	290	438	538	580
	750	54	65	81	94	125	150	174	225	275	270	388	513	520
Thermal Capacity P₃ (kW) for gear unit with cooling coil														
20 to 100	1500	89	105	126	129	176	207	261	310	391	368	461	500	584
	1000	85	102	116	119	167	200	235	300	375	324	445	475	522
	750	84	96	111	110	150	188	220	287	370	313	436	450	517
Thermal Capacity P₄ (kW) for gear unit with fan and cooling coil														
20 to 100	1500	130	160	199	204	281	339	435	509	660	711	905	1111	1141
	1000	121	148	178	187	268	320	391	495	611	614	860	1055	1021
	750	117	140	168	174	248	297	360	463	580	564	803	1000	1011

Nominal Power Rating (kW) Bevel Helical - Quadruple Stage

Type - K4

i _N	n1	n2	Gear unit Size											
			17	18	19	20	21	22	23	24	25	26		
80	1500	18.8		18				48				154		
	1000	12.5		12				32				103		
	750	9.4		9				24				77		
90	1500	16.7		16				42				137		
	1000	11.1		10				28				91		
	750	8.3		8				21				69		
100	1500	15.0		14	19			38	51			123	164	
	1000	10.0		9	13			25	34			81	105	
	750	7.5		7	10			19	26			63	80	
112	1500	13.4	7.1	12	16	24		34	46	59		108	138	160
	1000	8.9	4.8	8.8	12	16		23	31	39		75	88	105
	750	6.7	3.6	6.3	8.8	12		18	24	29		55	66	83
125	1500	12.0	6.5	11	15	23		30	41	64		98	121	160
	1000	8.0	4.3	7.5	11	15		20	29	43		66	81	107
	750	6.0	3.3	5.8	8.1	11		15	21	32		50	60	80
140	1500	10.7	5.8	10	14	19		28	36	57		88	109	145
	1000	7.1	3.8	6.9	9.4	12		19	26	38		60	73	97
	750	5.4	2.9	5.1	6.9	9.4		14	20	28		45	55	73
160	1500	9.4	5.3	9.4	13	17		25	34	41		79	95	115
	1000	6.3	3.5	6.1	8.6	11		16	23	27		53	64	75
	750	4.7	2.6	4.5	6.3	8.4		13	18	21		40	49	58
180	1500	8.3	4.7	8.1	11	15		21	30	37		71	86	100
	1000	5.6	3.1	5.4	7.5	9.7		15	20	25		48	58	68
	750	4.2	2.3	4.0	5.6	7.3		11	15	19		36	44	51
200	1500	7.5	4.1	7.3	10	13		19	28	33		64	78	92
	1000	5.0	2.8	4.8	6.9	8.9		13	18	22		43	51	61
	750	3.8	2.1	3.6	5.2	6.7		10	14	17		33	38	44
225	1500	6.7	3.7	6.3	8.8	12		18	24	36		56	69	90
	1000	4.4	2.4	4.3	5.9	7.8		11	16	24		38	46	60
	750	3.3	1.9	3.3	4.5	5.8		8.8	12	18		29	35	45
250	1500	6.0	3.3	5.8	8.1	12		15	21	32		50	60	81
	1000	4.0	2.2	3.9	5.9	7.5		11	15	21		34	40	54
	750	3.0	1.6	2.9	4.5	5.6		8.1	11	16		25	30	41
280	1500	5.4	2.9	4.3	6.9	9.3		14	19	28		45	55	72
	1000	3.6	1.9	2.9	4.8	6.2		9.4	13	19		30	36	48
	750	2.7	1.4	2.0	3.4	4.7		6.9	9.9	14		23	28	36
315	1500	4.8	2.6	3.9	6.3	8.4		12	18	26		40	49	65
	1000	3.2	1.8	2.6	4.3	5.6		8.1	11	17		26	31	43
	750	2.4	1.3	1.9	3.2	4.2		6.3	8.8	13		20	25	32
355	1500	4.2	2.3	3.5	5.8	8.1		11	14	18		29	44	49
	1000	2.8	1.6	2.4	3.8	5.4		7.5	9.4	12		20	29	33
	750	2.1	1.2	1.6	2.9	4.0		5.5	6.9	9.1		15	21	25
400	1500	3.8	2.1	3.0	4.8	6.3		9.4	11	16		24	35	43
	1000	2.5	1.4	1.9	3.1	4.1		6.3	7.5	11		16	24	29
	750	1.9	1.0	1.5	2.4	3.1		4.6	5.6	8.1		12	18	21
450	1500	3.3	1.6		3.8	5.8		11	18			35	44	
	1000	2.2	1.1		2.5	3.9		7.5	12			23	30	
	750	1.7	0.9		1.9	2.9		5.6	8.9			18	21	
500	1500	3.0	1.6		3.6	4.8		8.8	16			28	31	
	1000	2.0	1.1		2.4	3.1		5.8	11			19	21	
	750	1.5	0.9		1.8	2.4		4.3	8.0			14	15	
560	1500	2.7	1.4		3.2	4.6		7.5	14			25	28	
	1000	1.8	1.0		2.1	3.1		5.0	9.0			16	19	
	750	1.3	0.8		1.6	2.3		3.8	6.8			13	14	

Thermal Capacity (kW)

Nominal Transmission Ration i _N	n1	Gear unit Size									
		17	18	19	20	21	22	23	24	25	26
Thermal Capacity P ₁ (kW) for gear unit without cooling											
80 to 560	1500	20	28	35	41	56	75	76	138	177	206
	1000	17	23	30	36	50	69	66	127	148	178
	750	17	20	29	36	44	56	62	118	142	177

Actual Ratio - Helical Type - S1, S2, S3, S4

Type	i _N	Gear unit Size														
		11	13	14	15	16	17	18	19	20	21	22	23	24	25	26
S1	1.25	1.21	1.24	-	1.25	-	1.26	1.23	-	1.25	1.26	1.25	-	-	-	-
	1.4	1.38	1.39	-	1.35	-	1.39	1.42	-	1.38	1.40	1.40	-	-	-	-
	1.6	1.58	1.61	-	1.58	-	1.61	1.59	-	1.58	1.61	1.61	1.61	1.59	1.56	-
	1.8	1.82	1.82	-	1.79	-	1.78	1.76	-	1.82	1.77	1.77	1.77	1.83	1.78	1.81
	2	1.95	2.00	-	2.00	-	1.95	2.00	-	1.95	2.00	2.00	2.00	2.00	1.95	2.04
	2.24	2.29	2.24	-	2.25	-	2.26	2.22	-	2.26	2.21	2.24	2.24	2.24	2.20	2.27
	2.5	2.45	2.50	-	2.44	-	2.45	2.41	-	2.43	2.53	2.53	2.53	2.45	2.50	2.48
	2.8	2.78	2.83	-	2.75	-	2.78	2.71	-	2.79	2.75	2.72	2.80	2.67	2.85	2.79
	3.15	3.11	3.18	-	3.06	-	3.25	3.12	-	3.24	3.06	3.19	3.17	3.05	3.10	3.14
	3.55	3.53	3.53	-	3.50	-	3.75	3.53	-	3.65	3.50	3.53	3.69	3.53	3.53	3.62
	4	4.12	3.88	-	3.94	-	4.12	3.89	-	4.12	3.90	4.00	4.06	3.81	4.00	4.11
	4.5	4.47	4.38	-	4.44	-	4.61	4.50	-	4.59	4.39	4.45	4.56	4.38	4.38	4.59
5	5.06	5.00	-	5.00	-	5.28	4.88	-	5.11	5.00	5.00	5.05	4.82	5.00	5.06	
S2	5.6	-	-	5.31	5.56	5.56	5.89	5.57	5.65	5.80	5.57	5.57	5.69	5.68	5.60	5.78
	6.3	-	-	6.06	6.13	6.44	6.51	6.32	6.35	6.37	6.17	6.48	6.31	6.26	6.43	6.61
	7.1	-	-	6.93	6.79	7.29	7.43	7.06	7.16	7.39	7.00	7.13	7.21	7.06	7.09	7.38
	8	-	-	7.95	7.78	8.00	8.45	7.94	7.78	8.16	7.78	7.82	8.28	7.80	8.00	8.13
	9	-	-	8.54	8.75	8.94	9.49	8.60	8.95	8.96	8.44	9.00	8.89	8.93	8.95	9.18
	10	-	-	10.00	9.68	10.00	10.38	9.71	10.12	10.38	9.47	10.22	10.31	9.71	10.11	10.27
	11.2	-	-	10.72	10.91	11.33	11.39	10.80	11.00	11.24	10.91	11.06	11.06	10.80	10.89	11.59
	12.5	-	-	12.15	12.03	12.71	13.06	12.35	12.75	12.75	12.35	12.47	12.71	12.35	12.75	12.85
	14	-	-	13.59	13.56	14.12	14.86	13.92	13.88	14.91	13.61	14.12	14.74	13.76	14.12	14.53
	16	-	-	15.44	15.75	15.50	16.27	15.69	16.00	17.21	15.75	16.00	16.61	15.49	16.00	16.92
	18	-	-	18.01	17.09	17.50	18.44	17.65	18.00	18.89	17.09	17.78	18.76	17.65	17.80	18.62
	20	-	-	19.57	19.35	20.00	20.17	19.62	20.00	21.16	19.50	20.00	20.90	19.65	20.00	20.90
22.4	-	-	22.13	21.82	22.12	22.77	22.11	22.75	24.22	21.49	22.12	23.28	21.90	23.00	23.17	
S3	25	-	-	-	25.34	25.03	24.50	24.91	25.31	24.14	24.87	25.26	26.40	24.64	25.17	26.13
	28	-	-	-	26.60	27.48	27.65	27.45	29.18	27.03	27.79	28.63	29.41	27.45	28.52	28.96
	31.5	-	-	-	29.98	31.02	31.15	30.94	32.82	30.94	30.63	31.81	33.09	30.59	31.73	32.82
	35.5	-	-	-	34.82	34.59	36.01	34.86	34.71	35.42	35.44	35.71	36.62	34.42	36.08	36.36
	40	-	-	-	37.51	37.98	39.39	38.51	40.00	38.90	37.79	40.47	40.81	38.51	40.89	40.81
	45	-	-	-	42.28	42.88	44.45	43.40	45.00	43.56	47.64	44.97	45.46	42.91	45.49	45.24
	50	-	-	-	49.10	50.66	51.23	48.90	49.00	48.75	48.18	49.00	52.11	48.29	49.83	51.95
	56	-	-	-	55.24	55.62	56.04	52.71	56.47	53.53	54.90	55.53	58.06	52.71	56.47	58.31
	63	-	-	-	60.91	62.79	63.24	60.31	63.53	59.94	60.49	61.70	64.68	60.31	62.82	64.63
	71	-	-	-	68.66	71.76	70.70	67.97	70.59	68.82	70.00	69.41	68.41	67.20	70.59	73.24
	80	-	-	-	79.73	77.23	83.07	76.59	80.00	75.57	75.95	80.00	77.24	75.63	80.00	76.68
	90	-	-	-	-	84.79	93.75	89.42	90.00	84.63	94.14	88.89	86.07	87.35	89.00	86.07
100	-	-	-	-	95.74	105.61	100.78	100.00	96.86	106.57	100.00	95.88	97.16	100.00	95.41	
112	-	-	-	-	109.41	114.75	113.55	110.59	105.94	117.43	113.75	110.32	111.18	110.59	108.11	
S4	125	-	-	-	-	-	-	122.88	123.05	122.08	122.00	128.72	117.19	125.07	126.32	130.13
	140	-	-	-	-	-	-	138.48	141.82	138.41	134.43	145.88	134.61	139.37	143.16	144.22
	160	-	-	-	-	-	-	156.04	159.55	161.94	155.56	162.09	156.12	156.84	159.26	163.11
	180	-	-	-	-	-	-	173.30	170.06	186.86	171.16	176.47	175.99	170.03	178.55	189.94
	200	-	-	-	-	-	-	195.31	196.00	205.18	188.60	200.00	197.64	189.47	202.35	209.06
	224	-	-	-	-	-	-	220.07	220.50	229.77	218.24	222.22	223.14	213.22	225.12	234.65
	250	-	-	-	-	-	-	247.06	249.07	262.99	236.78	249.13	248.64	247.06	244.98	260.12
	280	-	-	-	-	-	-	278.43	287.06	287.90	268.05	282.35	276.97	275.29	277.65	294.74
	315	-	-	-	-	-	-	313.73	322.94	326.90	295.35	313.73	307.08	309.80	308.88	333.85
	355	-	-	-	-	-	-	352.94	358.82	374.17	341.76	352.94	342.17	352.94	347.06	370.09
	400	-	-	-	-	-	-	386.38	379.72	409.61	388.89	390.31	381.17	400.81	400.00	419.35
	450	-	-	-	-	-	-	434.67	437.65	432.73	421.93	442.35	433.52	456.62	445.00	440.92
500	-	-	-	-	-	-	-	492.35	484.59	-	491.50	483.07	-	500.00	494.88	
560	-	-	-	-	-	-	-	547.06	554.65	-	552.94	538.12	-	568.75	548.60	

Actual Ratio - Bevel Helical Type - K2, K3, K4

Type	i _N	Gear unit Size														
		11	13	14	15	16	17	18	19	20	21	22	23	24	25	26
K2	5	-	-	-	4.88	-	-	4.82	-	-	5.06	-	-	4.91	-	-
	5.6	-	5.67	-	5.50	-	-	5.41	-	-	5.50	5.44	-	5.33	5.70	-
	6.3	6.21	6.35	-	6.12	-	6.50	6.24	-	6.47	6.12	6.38	6.33	6.11	6.19	6.29
	7.1	7.06	7.06	-	7.00	-	7.50	7.06	-	7.29	7.00	7.06	7.38	7.06	7.05	7.24
	8	8.24	7.75	-	7.89	-	8.24	7.78	-	8.24	7.80	8.00	8.12	7.63	8.00	8.21
	9	8.95	8.75	-	8.89	-	9.22	9.00	-	9.18	8.78	8.90	9.11	8.75	8.75	9.18
	10	10.12	10.00	-	9.75	-	10.56	9.83	-	10.22	9.75	10.00	10.10	9.83	10.00	10.13
	11.2	10.88	10.79	-	10.99	-	11.56	10.83	-	11.50	10.86	11.14	11.44	10.62	11.14	11.50
	12.5	12.46	12.19	-	12.38	-	12.85	12.54	-	12.78	12.23	12.40	12.69	12.19	12.19	12.78
	14	14.09	13.93	-	14.00	-	14.70	14.12	-	14.24	14.00	13.93	14.07	14.12	13.93	14.10
	16	15.15	15.50	-	15.78	-	16.10	15.56	-	16.02	15.60	16.00	15.94	15.25	16.00	16.02
	18	17.89	17.50	-	17.78	-	18.44	18.00	-	18.35	17.56	17.80	18.22	17.50	17.50	18.35
	20	20.24	20.00	-	18.89	-	21.11	18.96	-	20.44	18.96	20.00	20.20	19.17	20.00	20.25
22.4	21.75	-	-	21.29	21.59	23.11	21.37	22.29	23.00	21.94	22.29	22.89	21.58	22.29	23.00	
K3	25	-	-	25.09	24.72	24.38	25.69	24.07	25.07	26.31	23.80	24.76	26.13	24.58	24.79	25.94
	28	-	-	27.26	27.12	27.86	28.10	27.22	27.86	29.47	27.22	27.86	29.11	27.53	27.86	29.11
	31.5	-	-	30.83	30.57	30.81	31.71	30.68	31.69	33.73	31.50	30.81	32.43	30.98	32.04	32.27
	35.5	-	-	33.13	35.50	35.00	35.73	34.57	36.00	36.92	34.18	35.56	36.49	35.29	35.60	36.57
	40	-	-	39.14	37.77	40.00	40.35	37.92	40.00	42.31	37.92	40.00	41.80	38.34	40.00	41.80
	45	-	-	44.26	42.58	44.24	45.53	42.73	45.50	48.43	43.88	44.24	46.57	43.15	46.00	46.34
	50	-	-	47.58	49.45	48.75	51.30	48.15	50.14	53.02	47.60	49.52	52.39	49.16	49.59	52.51
	56	-	-	54.52	54.24	55.71	56.20	54.44	55.71	58.94	54.44	55.71	58.23	55.06	55.71	58.23
	63	-	-	61.65	61.14	61.61	63.42	61.36	63.38	67.46	63.00	61.61	64.86	61.96	64.07	64.55
	71	-	-	66.27	71.00	70.00	71.45	69.14	72.00	73.85	68.35	71.11	72.97	70.59	71.20	73.14
	80	-	-	78.29	-	80.00	80.69	75.14	80.00	84.63	74.78	80.00	83.61	77.43	80.00	83.61
	90	-	-	88.53	-	88.47	91.07	87.26	91.00	96.86	84.26	88.47	93.14	86.28	92.00	92.68
	100	-	-	95.16	-	-	102.60	98.32	96.68	106.04	97.50	98.32	104.78	97.09	98.32	105.02
K4	112	-	-	-	-	-	112.53	110.61	111.43	115.53	105.78	111.43	116.09	110.61	111.43	116.37
	125	-	-	-	-	-	123.26	125.29	125.36	133.31	120.99	123.81	133.71	123.88	123.96	135.50
	140	-	-	-	-	-	139.69	141.18	139.29	146.38	140.00	139.29	150.96	139.41	139.29	149.15
	160	-	-	-	-	-	152.79	158.82	158.44	163.92	151.90	154.03	168.21	158.82	160.18	167.40
	180	-	-	-	-	-	172.43	174.52	180.00	187.62	168.52	177.78	187.38	172.55	178.00	185.57
	200	-	-	-	-	-	194.26	196.64	200.00	205.39	195.00	200.00	210.80	194.18	200.00	210.27
	224	-	-	-	-	-	219.39	221.22	227.50	235.37	211.57	221.18	216.76	221.22	230.00	214.16
	250	-	-	-	-	-	247.60	250.59	250.71	269.40	241.98	247.62	241.53	247.76	247.93	240.37
	280	-	-	-	-	-	278.94	282.35	278.57	294.92	280.00	278.57	269.06	278.82	278.57	266.46
	315	-	-	-	-	-	305.58	317.65	316.88	327.84	303.79	308.07	301.92	317.65	320.36	298.30
	355	-	-	-	-	-	344.86	346.52	360.00	375.24	343.64	355.56	336.42	342.19	356.00	334.80
	400	-	-	-	-	-	388.52	389.84	400.00	410.78	372.83	400.00	374.76	389.84	400.00	420.55
	450	-	-	-	-	-	438.78	-	455.00	470.74	-	442.35	433.52	-	460.00	428.33
500	-	-	-	-	-	495.19	-	490.91	538.80	-	490.91	483.07	-	490.91	480.75	
560	-	-	-	-	-	557.87	-	558.41	589.84	-	542.89	538.12	-	564.55	532.92	

type - S1HN

Single Stage
Size 11 to 18

Horizontal Mounting

Helical Gear Unit

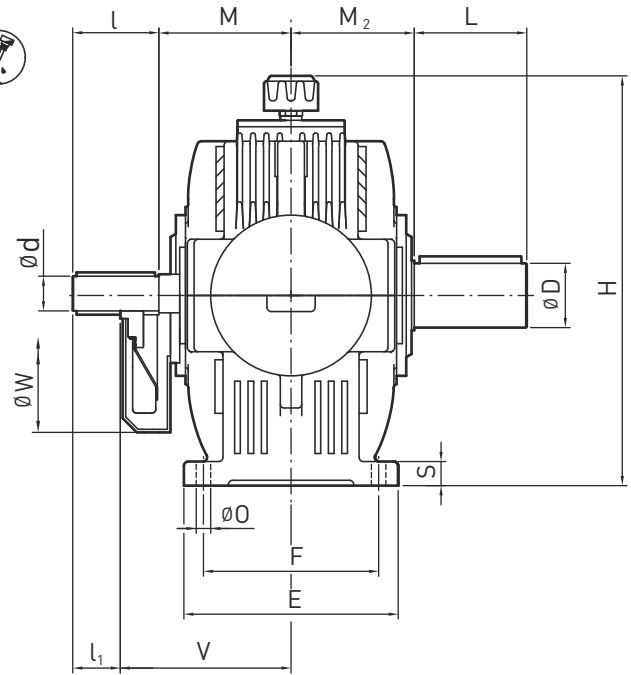
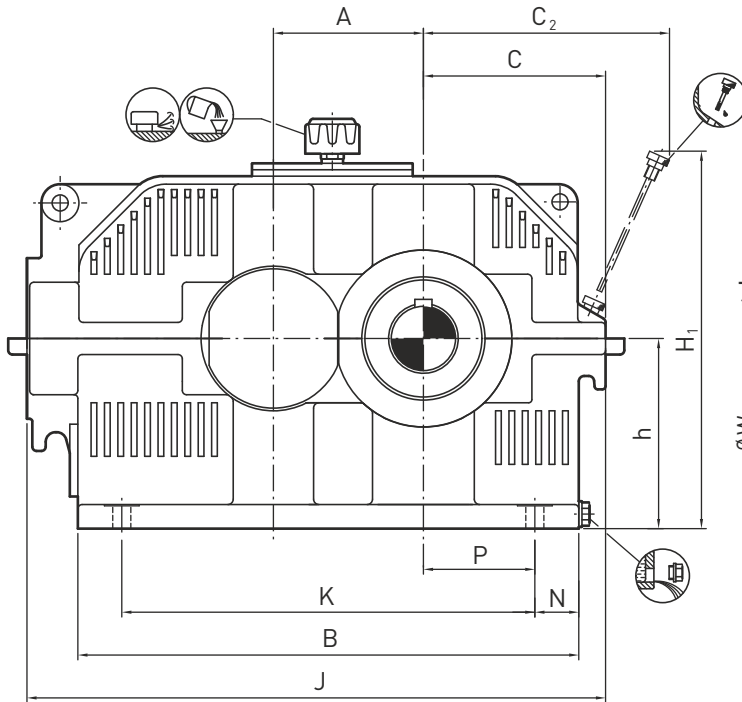

Size	Input Shaft						Output Shaft						Average Weight [kg]	Oil Quantity [Litres]
	i = 1.25 - 3.55			i = 4 - 5										
	d	l	l ₁	d	l	l ₁	M	V	W	D	L	M ₂		
S1..11	25	100	50	20	100	50	110	160	180	32	60	110	35	1.5
S1..13	35	110	60	30	110	60	150	200	180	45	90	125	65	2.5
S1..15	50	130	80	40	130	80	160	210	230	55	90	135	115	5.5
S1..17	60	155	105	50	130	80	165	215	300	70	125	150	205	9
S1..18	70	155	105	55	135	85	190	240	300	80	150	170	275	15

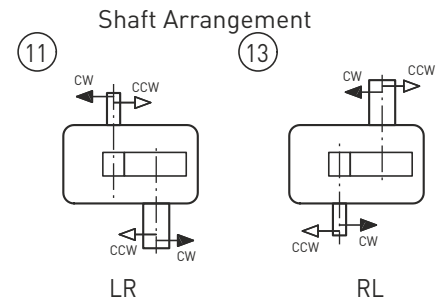

Size	Foundation														
	A	B	C	C ₂ ¹⁾	E	F	h	H ₁ ¹⁾	H ₂ ²⁾	J	K	N	O	P	S
S1..11	80	268	115	171	180	150	100	248	290	331	175	36	14	60	24
S1..13	100	349	135	195	190	150	125	295	340	415	220	37	14	75	24
S1..15	125	432	165	231	228	170	160	352	410	513	290	38	14	100	24
S1..17	160	536	205	282	250	210	200	432	480	637	350	48	18	120	32
S1..18	180	600	220	311	284	230	225	475	525	700	410	43	18	145	32

Modification of dimensions reserved.

Shaft ends with keys according to DIN 6885, part 1, Shape A.

Shaft centering according to DIN 332, shape DS (with thread)

Tolerance field for shaft ends ISO fit, up to Ø50 k6; over Ø50 m6.

1) Max. dimensions; details acc. to order related documents

2) Approximate values; exact values acc. to order related documents

Helical Gear Unit

Horizontal Mounting

Type - S1HN

Single Stage
Size 20 to 26

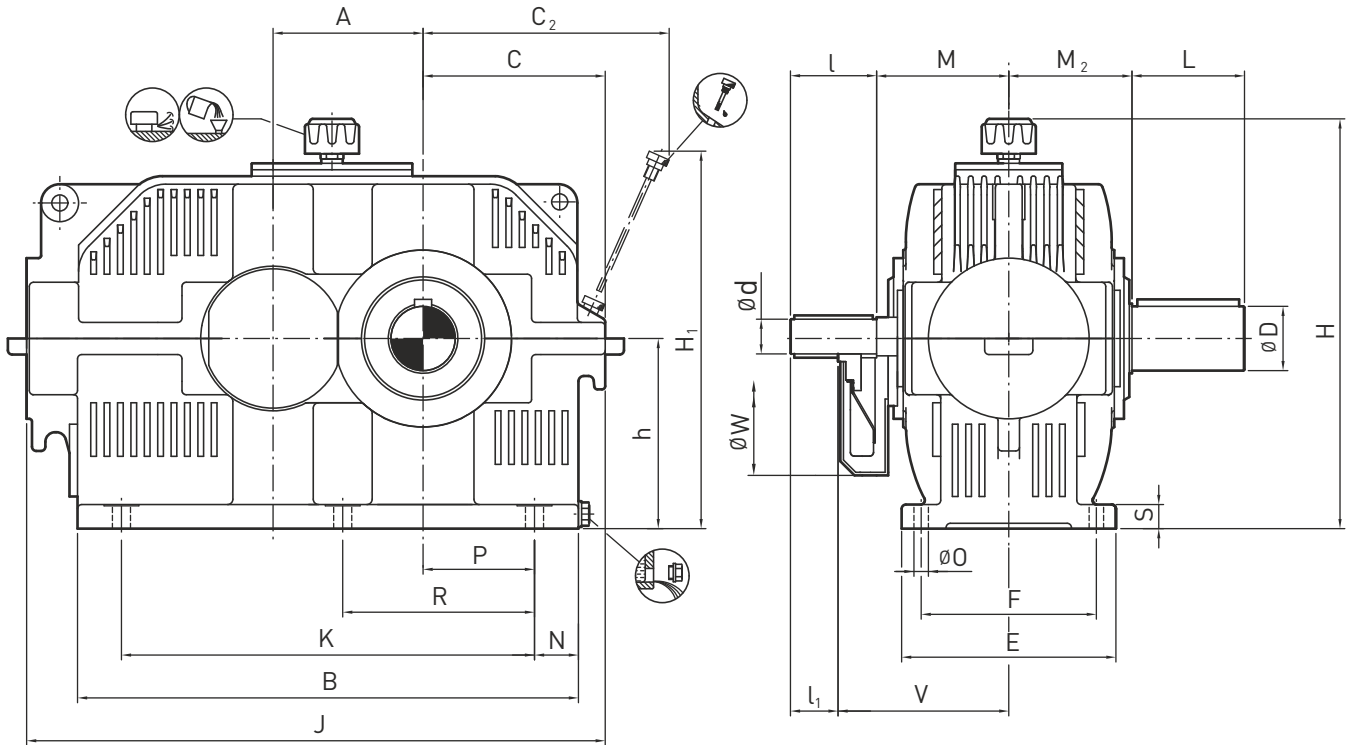

Size	Input Shaft						Output Shaft			Average Weight [kg]	Oil Quantity [Litres]			
	i = 1.25 - 3.55			i = 4 - 5			M	V	W					
	d	l	l ₁	d	l	l ₁	M	V	W	D	L	M ₂		
S1..20	85	180	130	70	155	105	215	265	380	100	175	210	320	25
S1..21	95	180	130	80	180	130	260	310	530	110	180	220	415	36
S1..22	105	220	170	90	180	130	270	320	530	120	200	230	570	50
S1..23	115	220	170	95	180	130	280	330	530	140	225	260	760	62
S1..24	130	250	200	110	220	170	320	370	530	160	260	295	1025	110
S1..25	145	250	200	120	220	170	360	410	600	170	270	305	1400	125
S1..26	160	300	250	130	250	200	360	410	600	190	300	345	1900	160

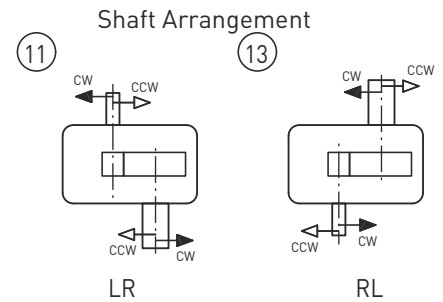

Size	Foundation															
	A	B	C	C ₂ ¹⁾	E	F	h	H ₁ ¹⁾	H ₂ ²⁾	J	K	N	O	P	R	S
S1..20	225	755	275	387	314	270	280	588	620	890	520	54	23	180		36
S1..21	250	843	305	435	385	310	315	664	685	980	570	64	27	195		45
S1..22	280	935	340	474	400	340	355	741	760	1080	630	75	27	215	370	45
S1..23	315	1054	375	537	450	380	400	831	845	1210	705	87	33	240	420	55
S1..24	355	1169	425	598	515	410	450	908	940	1340	810	87	33	280	480	55
S1..25	400	1311	475	670	535	460	500	1013	1040	1530	910	98	33	315	540	55
S1..26	450	1476	535	753	600	510	560	1137	1150	1720	1025	108	39	355	615	65

Modification of dimensions reserved.

Shaft ends with keys according to DIN 6885, part 1, Shape A.

Shaft centering according to DIN 332, shape DS (with thread)

Tolerance field for shaft ends ISO fit, up to Ø50 k6; over Ø50 m6.

1) Max. dimensions; details acc. to order related documents

2) Approximate values; exact values acc. to order related documents

type - S2H
Double Stage
Size 14 to 18

Horizontal Mounting

Helical Gear Unit

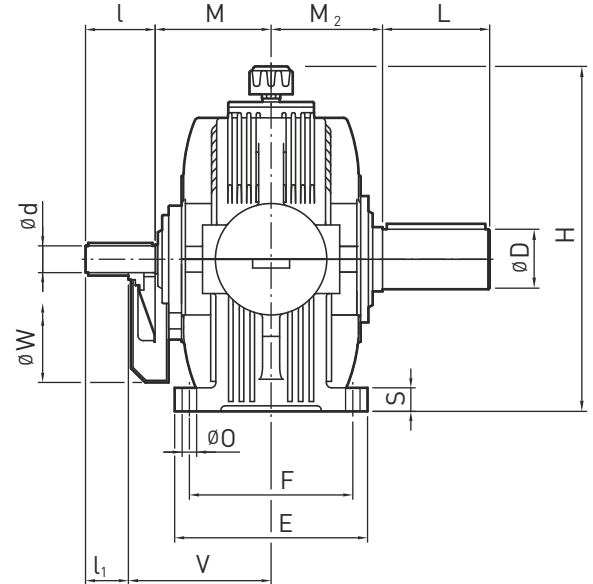
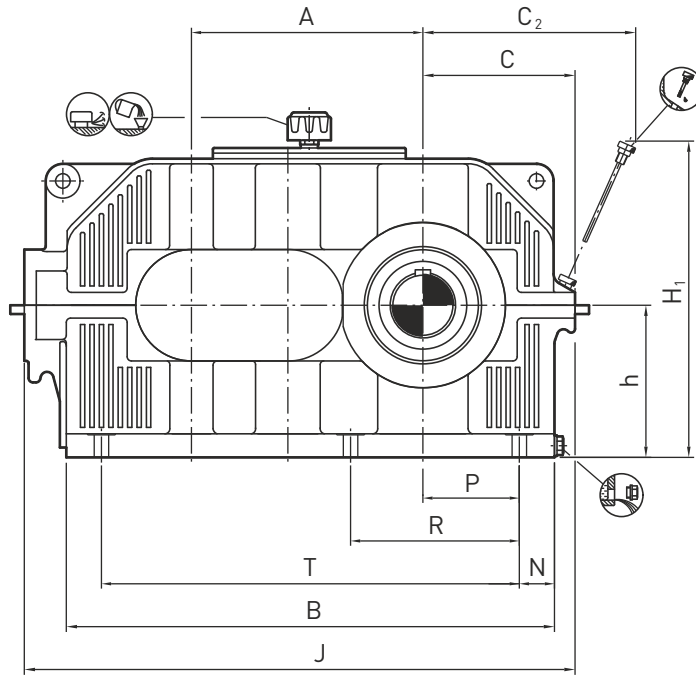

*For other shaft options refer page 60 to 64.

Size	Input Shaft									Output Shaft			Backstop		Average Weight [kg]	Oil Quantity [Litres]			
	i = 5.6 - 12.5			i = 14 - 18			i = 22.4			D	L	M ₂	d ₁ ¹⁾	Y ¹⁾					
	d	l	l ₁	d	l	l ₁	d	l	l ₁										
S2..14	25	100	55	20	100	55	20	100	55	140	185	210	48	95	125	95	190	58	2
S2..15	30	110	65	25	100	55				155	200	230	55	95	135	110	210	78	3
S2..16	35	110	65	30	110	65	20	100	55	155	200	270	60	130	145	135	220	110	4
S2..17	45	130	85	35	110	65	25	100	55	160	205	300	70	135	150	140	230	145	5
S2..18	50	130	85	40	130	85				180	225	300	80	160	170	150	250	200	8

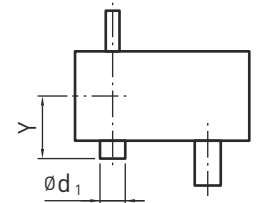

Size	Foundation															
	A	B	C	C ₂ ¹⁾	E	F	h	H ₁ ¹⁾	H ₂ ²⁾	J	N	O	P	R	S	T
S2..14	190	400	140	194	190	150	125	278	340	466	38	14	80	140	24	310
S2..15	215	460	155	215	228	170	140	306	370	526	38	14	95	170	24	355
S2..16	240	521	175	231	233	190	160	327	410	595	38	14	110	195	24	400
S2..17	270	580	190	257	250	210	180	378	450	664	43	18	115	210	32	440
S2..18	305	648	215	281	284	230	200	404	490	743	43	18	135	240	32	505

Modification of dimensions reserved.

Shaft ends with keys according to DIN 6885, part 1, Shape A.

Shaft centering according to DIN 332, shape DS (with thread)

Tolerance field for shaft ends ISO fit, up to Ø50 k6; over Ø50 m6.

1) Max. dimensions; details acc. to order related documents

2) Approximate values; exact values acc. to order related documents

Helical Gear Unit

Horizontal Mounting

Type - S2H

Single Stage
Size 19 to 26

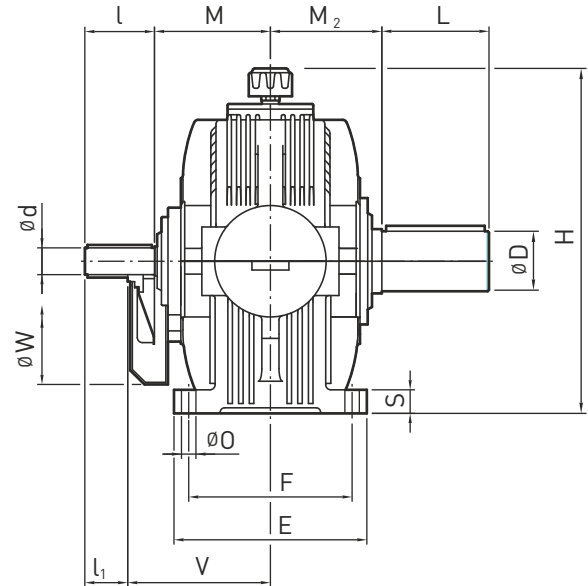
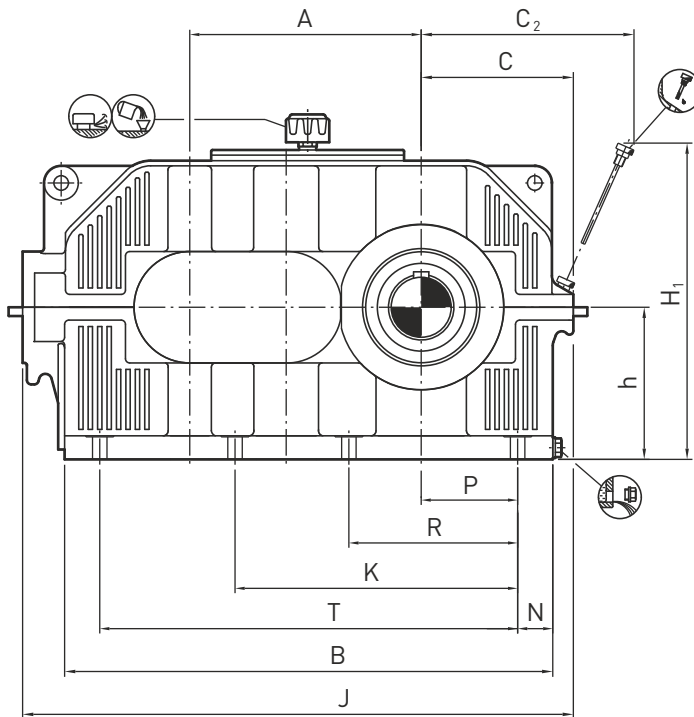

*For other shaft options refer page 60 to 64.

Size	Input Shaft									Output Shaft			Backstop		Average Weight [kg]	Oil Quantity [Litres]			
	i = 5.6 - 12.5			i = 14 - 18			i = 22.4			D	L	M ₂	d ₁ ¹⁾	Y ¹⁾					
	d	l	l ₁	d	l	l ₁	d	l	l ₁								M	V	W
S2..19	55	135	85	45	130	80	35	110	60	195	245	320	90	165	180	175	280	270	11
S2..20	60	155	105	50	130	80	40	130	80	205	255	360	100	200	200	190	295	360	14
S2..21	70	155	105	55	135	85				245	295	360	110	200	220	210	335	490	21
S2..22	75	155	105	60	155	105	55	135	85	260	310	430	120	210	230	210	345	675	29
S2..23	85	180	130	70	155	105	60	155	105	275	325	430	140	250	260	245	370	910	42
S2..24	95	180	130	80	180	130				340	390	450	160	290	295	290	445	1230	60
S2..25	105	220	170	90	180	130	70	155	105	350	400	550	170	300	305	290	455	1675	85
S2..26	115	220	170	95	180	130	80	180	130	350	400	550	190	350	345	310	465	2260	115

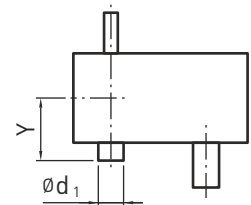

Size	Foundation																
	A	B	C	C ₂ ¹⁾	E	F	h	H ₁ ¹⁾	H ₂ ²⁾	J	N	K	O	P	R	S	T
S2..19	340	716	240	315	303	250	225	455	540	825	53		23	145	255	36	555
S2..20	385	807	260	345	314	270	250	496	590	917	54		23	165	290	36	635
S2..21	430	898	290	394	385	310	280	572	650	1020	64		27	180	315	45	705
S2..22	480	1010	325	429	400	340	315	635	720	1140	75		27	200	355	45	785
S2..23	540	1139	355	481	450	380	355	705	800	1285	87		33	220	405	55	875
S2..24	605	1269	390	541	515	410	400	795	890	1420	92		33	245	450	55	975
S2..25	680	1411	440	591	535	460	450	865	990	1580	98		33	280	510	55	1105
S2..26	765	1586	490	659	600	510	500	954	1090	1775	108	940	39	315	575	65	1245

Modification of dimensions reserved.

Shaft ends with keys according to DIN 6885, part 1, Shape A.
Shaft centering according to DIN 332, shape DS (with thread)

Tolerance field for shaft ends ISO fit, up to Ø50 k6; over Ø50 m6.

1) Max. dimensions; details acc. to order related documents

2) Approximate values; exact values acc. to order related documents

type - S2T
Double Stage
Size 14 to 18

Torque Arm Mounting

Helical Gear Unit

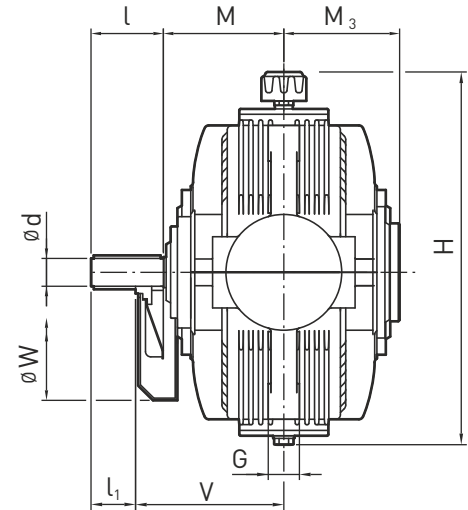
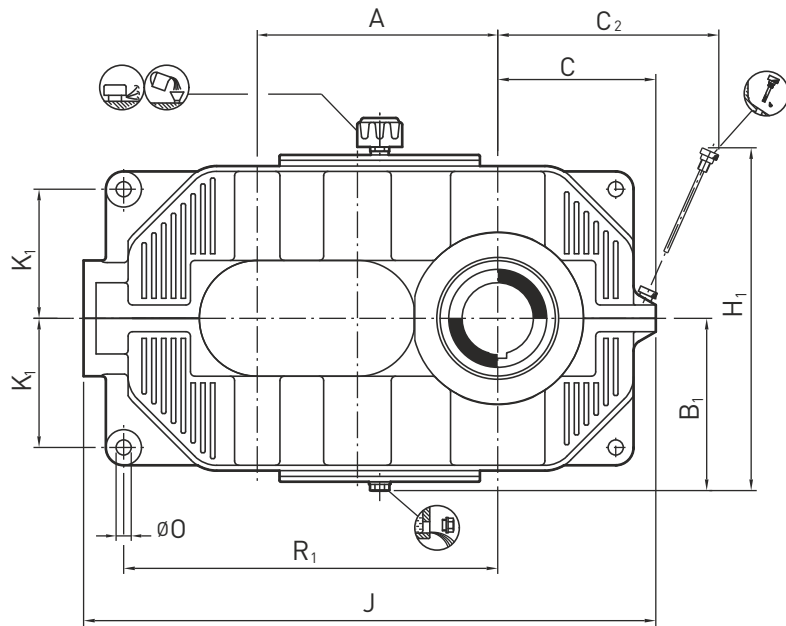

Size	Input Shaft												Output Shaft	Backstop		Average Weight [kg]	Oil Quantity [Litres]
	i = 5.6 - 12.5			i = 14 - 18			i = 22.4			M ₃	d ₁ ¹⁾	Y ¹⁾					
	d	l	l ₁	d	l	l ₁	d	l	l ₁					M	V		
S2..14	25	100	55	20	100	55	20	100	55	140	185	210	120	95	190	51	1
S2..15	30	110	65	25	100	55				155	200	230	135	110	210	68	2
S2..16	35	110	65	30	110	65	20	100	55	155	200	270	145	135	220	96	3
S2..17	45	130	85	35	110	65	25	100	55	160	205	300	150	140	230	127	4
S2..18	50	130	85	40	130	85				180	225	300	170	150	250	174	5

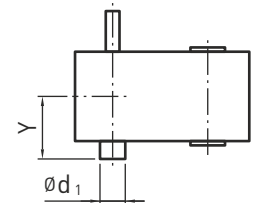

Size	Foundation										
	A	B ₁ ²⁾	C	C ₂ ¹⁾	G	H ₁ ¹⁾	H ²⁾	J	K ₁	O	R ₁
S2..14	190	155	140	194	25	308	370	466	90	18	300
S2..15	215	170	155	215	28	336	400	526	102	18	336
S2..16	240	190	175	231	30	357	440	595	115	20	380
S2..17	270	210	190	257	32	408	480	664	136	20	430
S2..18	305	230	215	281	35	434	520	743	146	24	478

Modification of dimensions reserved.

Shaft ends with keys according to DIN 6885, part 1, Shape A.

Shaft centering according to DIN 332, shape DS (with thread)

Tolerance field for shaft ends ISO fit, up to Ø50 k6; over Ø50 m6.

1) Max. dimensions; details acc. to order related documents

2) Approximate values; exact values acc. to order related documents

Helical Gear Unit

Torque Arm Mounting

Type - S2T

Double Stage
Size 19 to 26

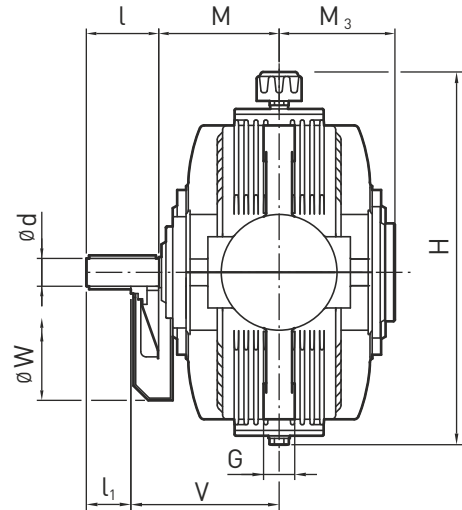
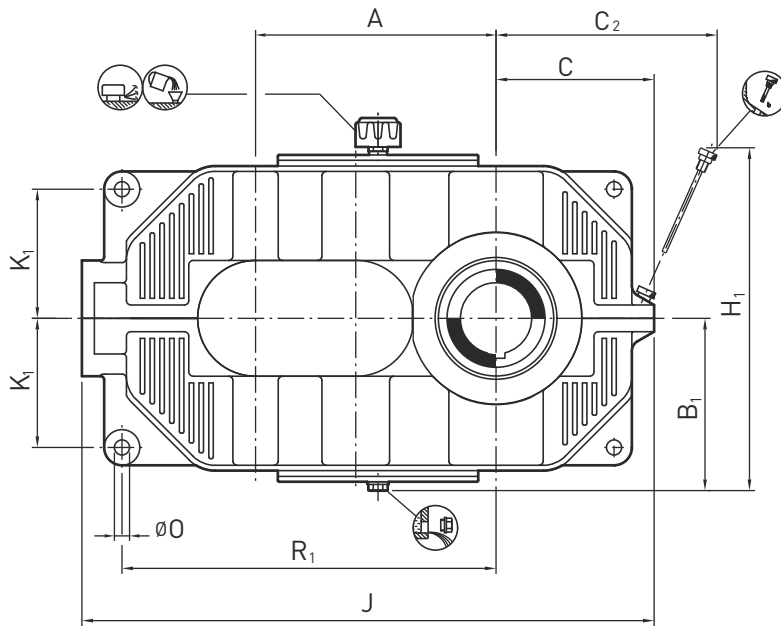

Size	Input Shaft									Output Shaft			Backstop		Average Weight [kg]	Oil Quantity [Litres]	
	i = 5.6 - 12.5			i = 14 - 18			i = 22.4			M ₃	d ₁ ¹⁾	Y ¹⁾					
	d	l	l ₁	d	l	l ₁	d	l	l ₁								
S2..19	55	135	85	45	130	80	35	110	60	195	245	320	180	175	280	235	6
S2..20	60	155	105	50	130	80	40	130	80	205	255	360	190	190	295	314	8
S2..21	70	155	105	55	135	85				245	295	360	220	210	335	428	12
S2..22	75	155	105	60	155	105	55	135	85	260	310	430	230	210	345	595	17
S2..23	85	180	130	70	155	105	60	155	105	275	325	430	260	245	370	800	24
S2..24	95	180	130	80	180	130				340	390	450	295	290	445	1080	35
S2..25	105	220	170	90	180	130	70	155	105	350	400	550	305	290	455	1475	50
S2..26	115	220	170	95	180	130	80	180	130	350	400	550	345	310	465	1990	65

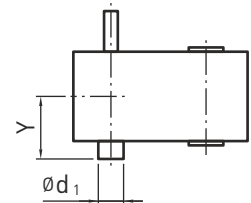

Size	Foundation										
	A	B ₁ ²⁾	C	C ₂ ¹⁾	G	H ₁ ¹⁾	H ²⁾	J	K ₁	O	R ₁
S2..19	340	255	240	315	45	485	570	825	170	24	525
S2..20	385	280	260	345	50	526	620	917	190	28	590
S2..21	430	310	290	394	55	602	680	1020	220	28	660
S2..22	480	345	325	429	60	665	750	1140	255	36	740
S2..23	540	385	355	481	70	735	830	1285	290	40	840
S2..24	605	430	390	541	80	825	920	1420	325	48	930
S2..25	680	480	440	591	90	895	1020	1580	370	48	1035
S2..26	765	530	490	659	105	984	1120	1775	415	55	1165

Modification of dimensions reserved.

Shaft ends with keys according to DIN 6885, part 1, Shape A.
Shaft centering according to DIN 332, shape DS (with thread)

Tolerance field for shaft ends ISO fit, up to Ø50 k6; over Ø50 m6.

1) Max. dimensions; details acc. to order related documents

2) Approximate values; exact values acc. to order related documents

Type - ۵۲
Double Stage

Shaft Arrangement

Helical Gear Unit

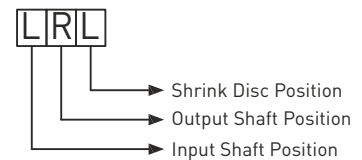
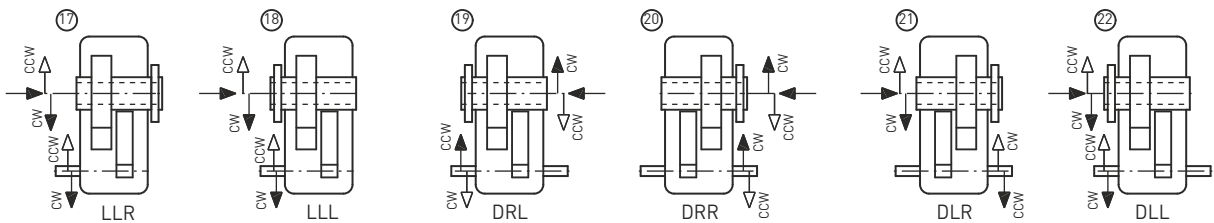
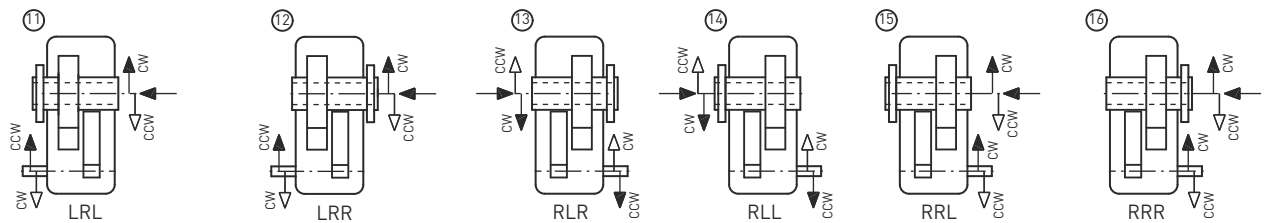
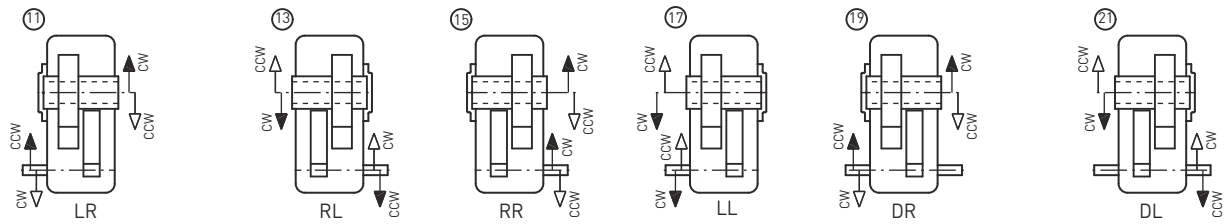
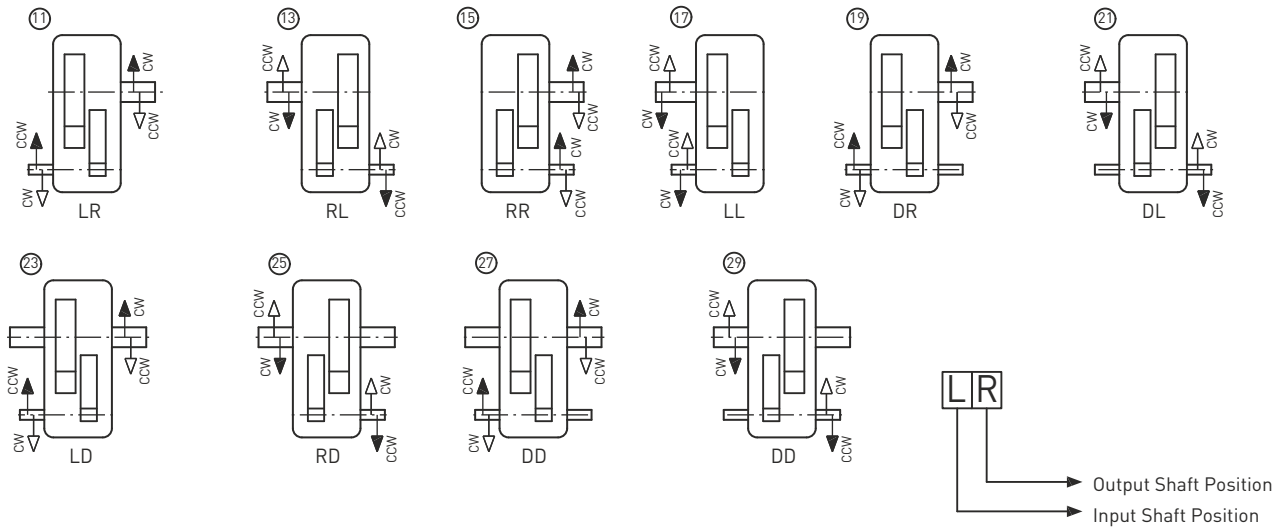

Helical Gear Unit

Shaft Arrangement - Hold Back

Type - S2
 Double Stage

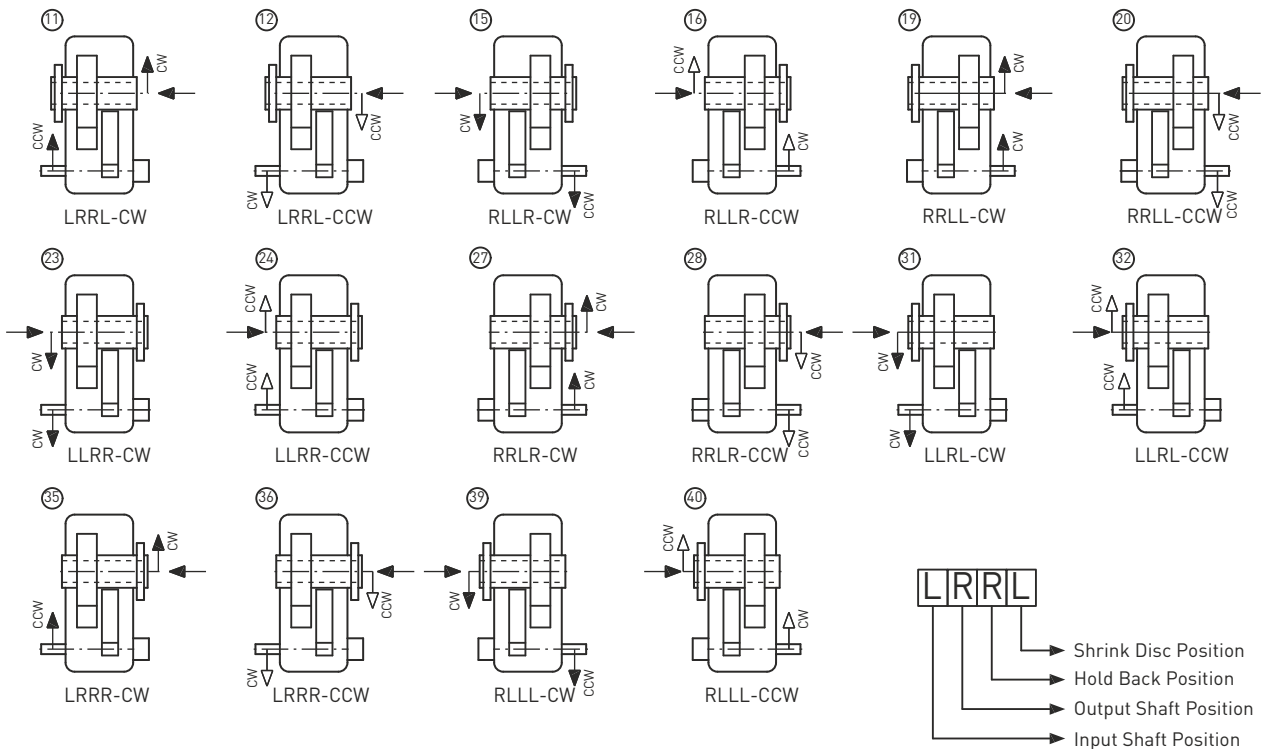
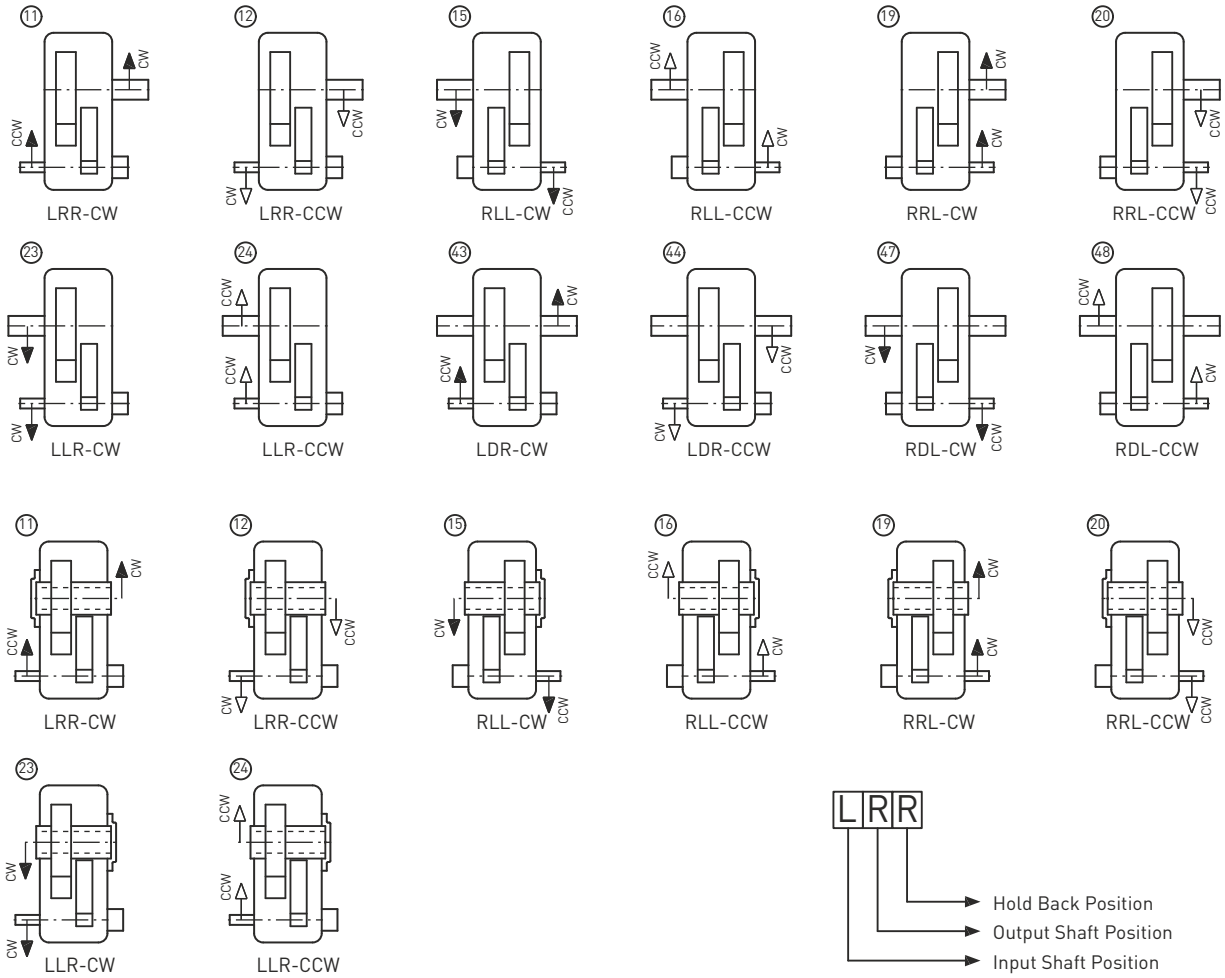

type - S3H

Triple Stage
Size 15 to 18

Horizontal Mounting

Helical Gear Unit

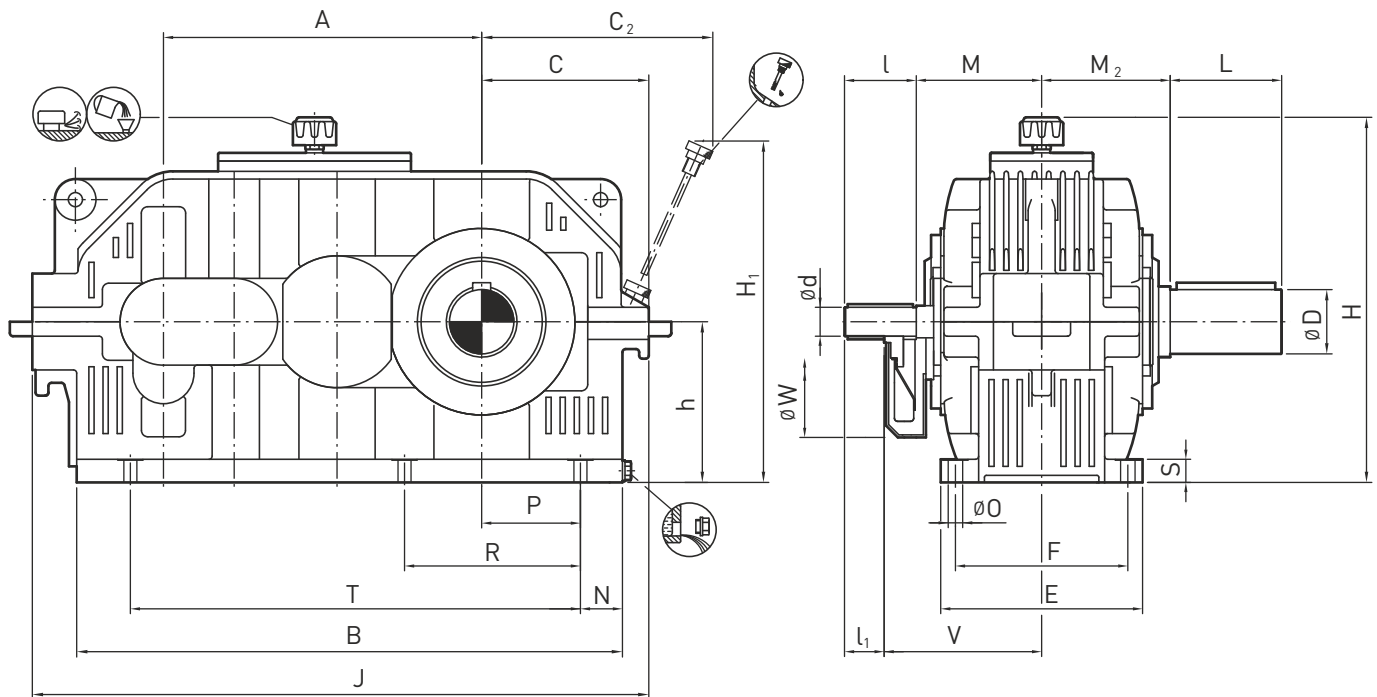

*For other shaft options refer page 60 to 64.

Size	Input Shaft									Output Shaft						Backstop			Average Weight [kg]	Oil Quantity [Litres]
	i = 20-50			i = 56-80			i = 112			D	L	M ₂	A ₁	d ₁ ¹⁾	Y ¹⁾					
	d	l	l ₁	d	l	l ₁	d	l	l ₁							M	V	W		
S3..15	24	100	50	19	100	50				145	195		55	95	135				105	5
S3..16	24	100	50	19	100	50	19	100	50	155	205	270	60	130	145	240	95	215	120	7
S3..17	28	100	50	24	100	50	19	100	50	160	210	270	70	135	150	270	95	215	160	8
S3..18	30	110	60	25	100	50				180	230	300	80	160	170	305	140	265	215	10

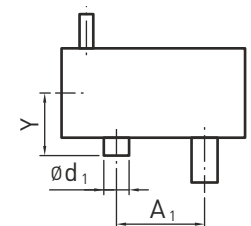

Size	Foundation															
	A	B	C	C ₂ ¹⁾	E	F	h	H ₁ ¹⁾	H ₂ ²⁾	J	N	O	P	R	S	T
S3..15	278	482	155	215	228	170	140	306	370	526	38	14	95	170	24	395
S3..16	311	537	175	231	233	190	160	327	410	592	38	14	110	195	24	450
S3..17	350	592	190	257	250	210	180	378	450	676	43	18	115	210	32	495
S3..18	395	671	215	281	284	230	200	404	490	766	43	18	135	240	32	565

Modification of dimensions reserved.

Shaft ends with keys according to DIN 6885, part 1, Shape A.

Shaft centering according to DIN 332, shape DS (with thread)

Tolerance field for shaft ends ISO fit, up to Ø50 k6; over Ø50 m6.

1) Max. dimensions; details acc. to order related documents

2) Approximate values; exact values acc. to order related documents

Helical Gear Unit

Horizontal Mounting

Type - S3H

Triple Stage
Size 19 to 26

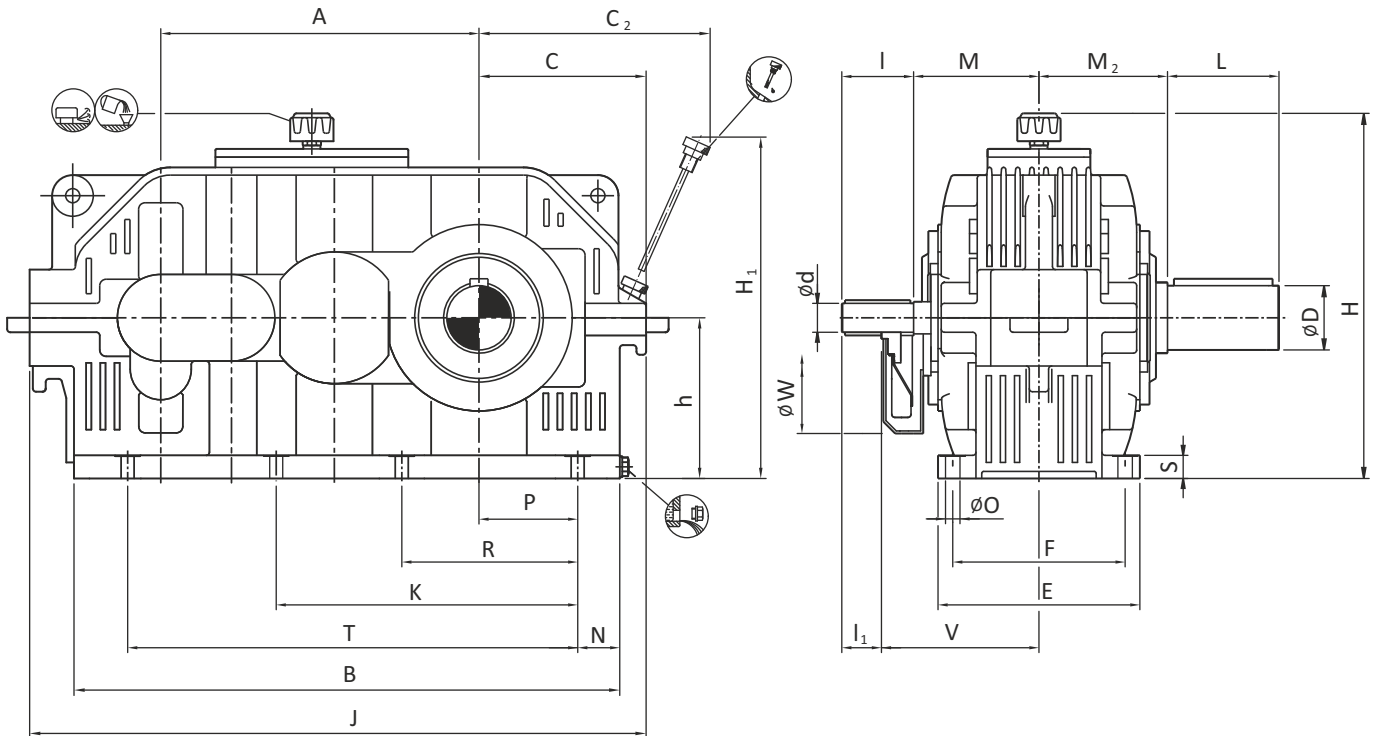

*For other shaft options refer page 60 to 64.

Size	Input Shaft									Output Shaft						Backstop			Average Weight [kg]	Oil Quantity [Litres]
	i = 20 - 50 i = 25 - 63 i = 25 - 71			i = 56 - 80 i = 71 - 100 i = 80 - 100			i = 112			M	V	W	D	L	M ₂	A ₁	d ₁ ¹⁾	Y ¹⁾		
d	l	l ₁	d	l	l ₁	d	l	l ₁	M										V	W
S3..19	35	110	60	30	110	60	25	100	50	190	240	320	90	165	180	340	150	265	295	14
S3..20	45	130	80	35	110	60	25	100	50	195	245	360	100	200	200	385	150	265	405	22
S3..21	50	130	80	40	130	80				240	290	360	110	200	220	430	190	340	540	28
S3..22	55	135	85	45	130	80	35	110	60	250	300	430	120	210	230	480	190	340	720	39
S3..23	60	155	105	50	130	80	40	130	80	270	320	430	140	250	260	540	190	340	970	56
S3..24	70	155	105	55	135	85				325	375	450	160	290	295	605	245	440	1300	80
S3..25	75	155	105	60	155	105	50	130	80	335	385	450	170	300	305	680	245	440	1770	115
S3..26	85	180	130	70	155	105	70	155	105	350	400	450	190	350	345	765	245	440	2350	165

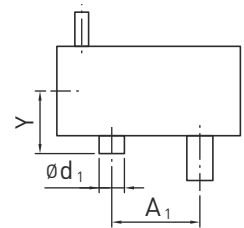

Size	Foundation																
	A	B	C	C ₂ ¹⁾	E	F	h	H ₁ ¹⁾	H ₂ ²⁾	J	K	N	O	P	R	S	T
S3..19	440	751	240	315	303	250	225	455	540	860		53	23	145	255	36	615
S3..20	495	849	260	345	314	270	250	496	590	959		54	23	165	290	36	705
S3..21	555	946	290	394	385	310	280	572	650	1068		64	27	180	315	45	780
S3..22	620	1060	325	429	400	340	315	635	720	1190		75	27	200	355	45	880
S3..23	700	1181	355	481	450	380	355	705	800	1327	655	87	33	220	405	55	985
S3..24	785	1324	390	541	515	410	400	795	890	1475	740	92	33	245	450	55	1110
S3..25	880	1496	440	591	535	460	450	865	990	1655	840	98	33	280	510	55	1245
S3..26	990	1686	490	659	600	510	500	954	1090	1870	940	108	39	315	575	65	1400

Modification of dimensions reserved.

Shaft ends with keys according to DIN 6885, part 1, Shape A.
Shaft centering according to DIN 332, shape DS (with thread)

Tolerance field for shaft ends ISO fit, up to Ø50 k6; over Ø50 m6.

1) Max. dimensions; details acc. to order related documents

2) Approximate values; exact values acc. to order related documents

type - S3T
Triple Stage
Size 14 to 18

Torque Arm Mounting

Helical Gear Unit

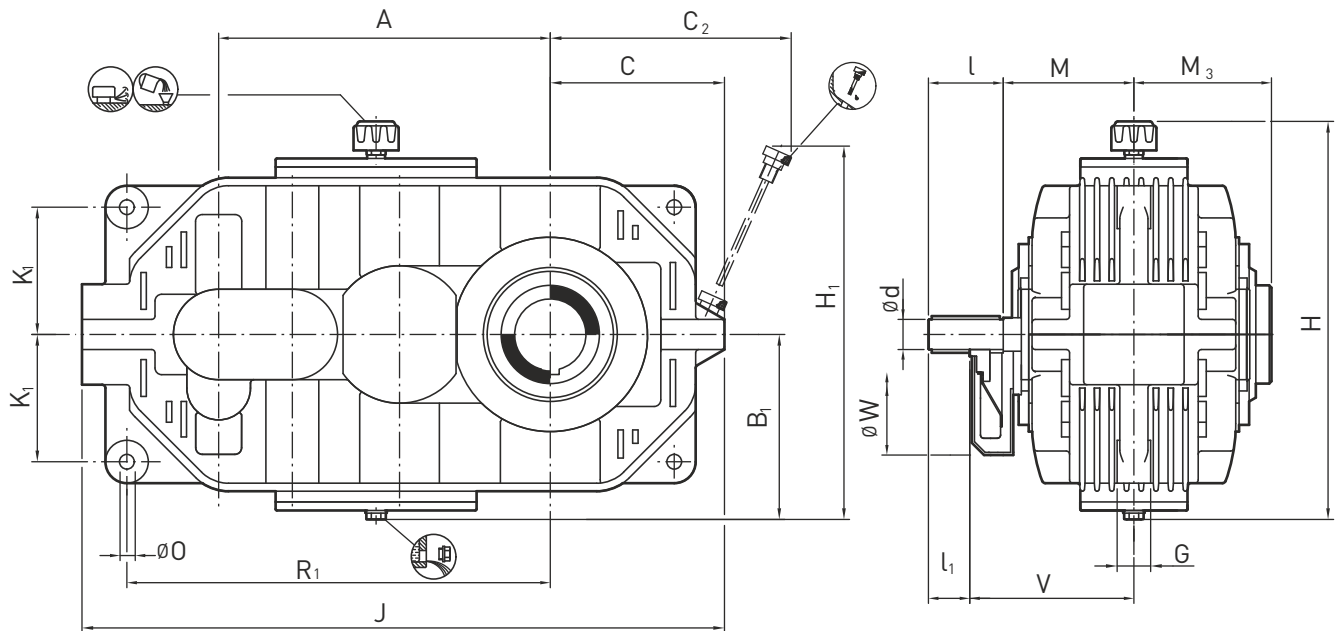

Size	Input Shaft									Output Shaft	Backstop			Average Weight [kg]	Oil Quantity [Litres]			
	i = 20-50			i = 56-80			i = 112				M ₃	A ₁	d ₁ ¹⁾			Y ¹⁾		
	d	l	l ₁	d	l	l ₁	d	l	l ₁								M	V
S3..15	24	100	50	19	100	50				145	195	135				95	3	
S3..16	24	100	50	19	100	50	19	100	50	155	205	270	145	240	95	215	105	3
S3..17	28	100	50	24	100	50	19	100	50	160	210	270	150	270	95	215	141	5
S3..18	30	110	60	25	100	50				180	230	300	170	305	140	265	188	7

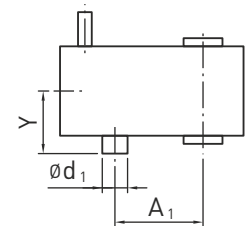

Size	Foundation										
	A	B ₁ ²⁾	C	C ₂ ¹⁾	G	H ²⁾	H ₁ ¹⁾	J	K ₁	O	R ₁
S3..15	278	170	155	215	28	400	336	526	102	18	347
S3..16	311	190	175	231	30	440	357	592	116	20	392
S3..17	350	210	190	257	32	480	408	676	136	20	442
S3..18	395	230	215	281	35	520	434	766	145	24	500

Modification of dimensions reserved.

Shaft ends with keys according to DIN 6885, part 1, Shape A.

Shaft centering according to DIN 332, shape DS (with thread)

Tolerance field for shaft ends ISO fit, up to Ø50 k6; over Ø50 m6.

1) Max. dimensions; details acc. to order related documents

2) Approximate values; exact values acc. to order related documents

Helical Gear Unit

Torque Arm Mounting

Type - S3T

Triple Stage
Size 19 to 26

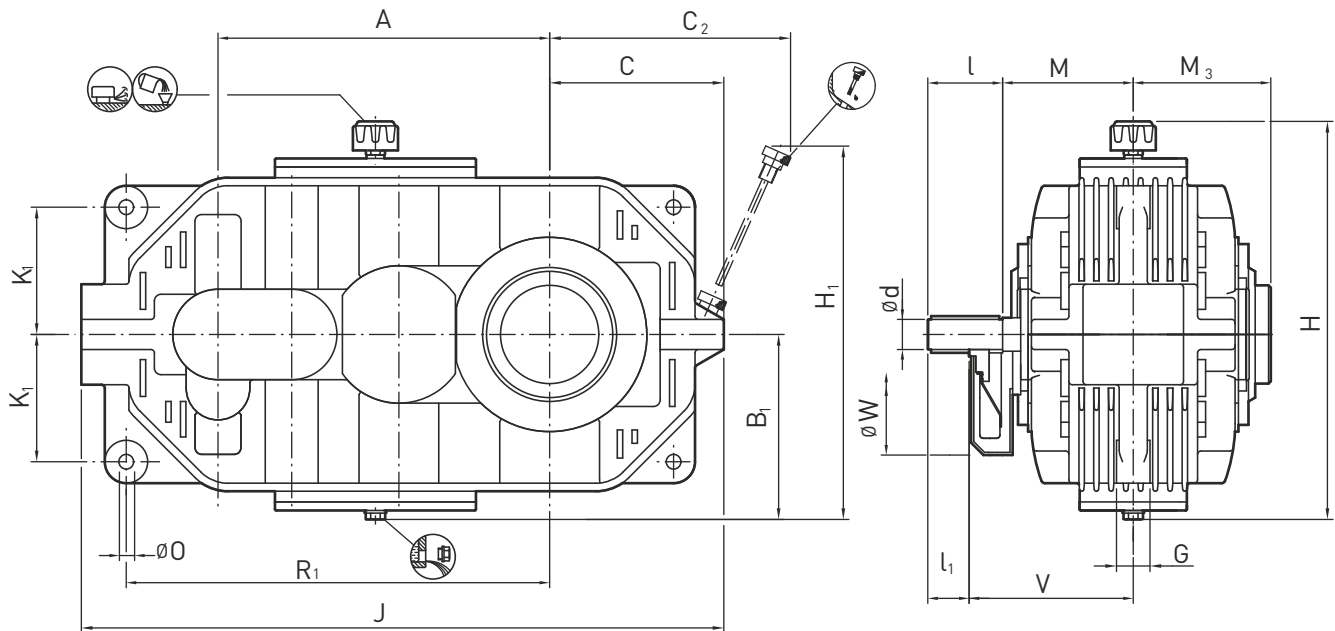

Size	Input Shaft									Output Shaft			Backstop			Average Weight [kg]	Oil Quantity [Litres]	
	i = 20 - 50			i = 56 - 80			i = 112											
	d	l	l ₁	d	l	l ₁	d	l	l ₁	M	V	W	M ₃	A ₁	d ₁ ¹⁾			Y ¹⁾
S3..19	35	110	60	30	110	60	25	100	50	190	240	320	180	340	150	265	257	9
S3..20	45	130	80	35	110	60	25	100	50	195	245	360	190	385	150	265	345	11
S3..21	50	130	80	40	130	80				240	290	360	220	430	190	340	460	17
S3..22	55	135	85	45	130	80	35	110	60	250	300	430	230	480	190	340	610	23
S3..23	60	155	105	50	130	80	40	130	80	270	320	430	260	540	190	340	820	36
S3..24	70	155	105	55	135	85				325	375	450	295	605	245	440	1100	50
S3..25	75	155	105	60	155	105	50	130	80	335	385	450	305	680	245	440	1520	70
S3..26	85	180	130	70	155	105	70	155	105	350	400	450	345	765	245	440	2000	100

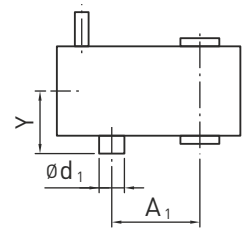

Size	Foundation										
	A	B ₁ ²⁾	C	C ₂ ¹⁾	G	H ²⁾	H ₁ ¹⁾	J	K ₁	O	R ₁
S3..19	440	255	240	315	45	570	485	860	170	24	560
S3..20	495	280	260	345	50	620	526	959	190	28	632
S3..21	555	310	290	394	55	680	602	1068	222	28	710
S3..22	620	345	325	429	60	750	665	1190	255	36	790
S3..23	700	385	355	481	70	830	735	1327	290	40	882
S3..24	785	430	390	541	80	920	830	1475	325	48	985
S3..25	880	480	440	591	90	1020	900	1655	370	48	1115
S3..26	990	530	490	659	105	1120	989	1870	415	55	1265

Modification of dimensions reserved.

Shaft ends with keys according to DIN 6885, part 1, Shape A.

Shaft centering according to DIN 332, shape DS (with thread)

Tolerance field for shaft ends ISO fit, up to Ø50 k6; over Ø50 m6.

1) Max. dimensions; details acc. to order related documents

2) Approximate values; exact values acc. to order related documents

Type - 3D
Triple Stage

Shaft Arrangement

Helical Gear Unit

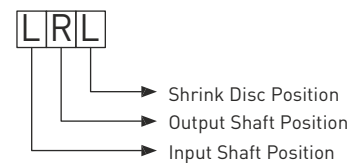
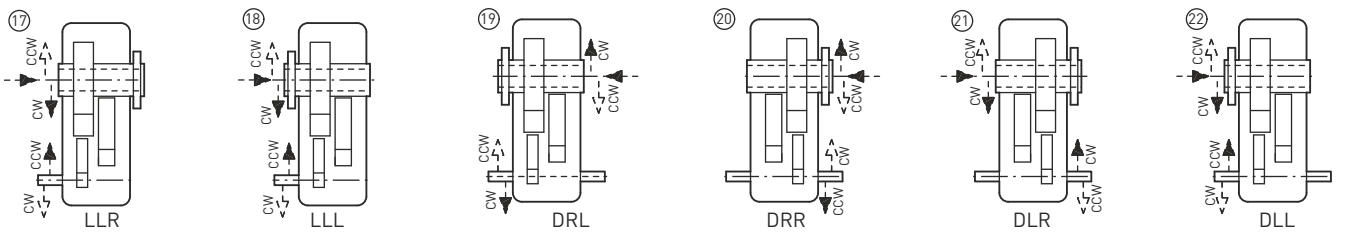
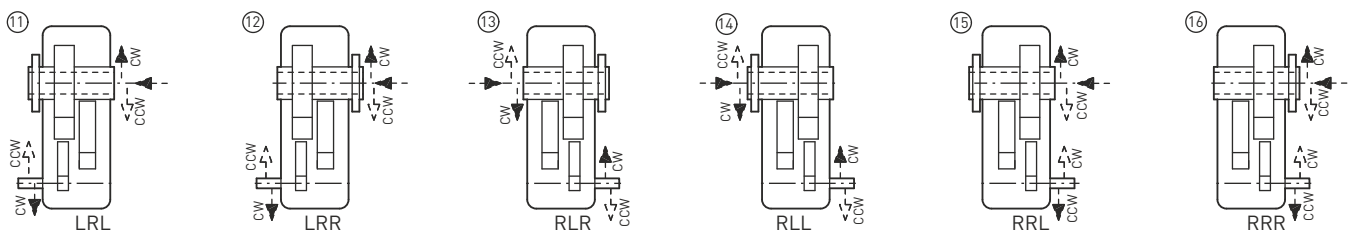
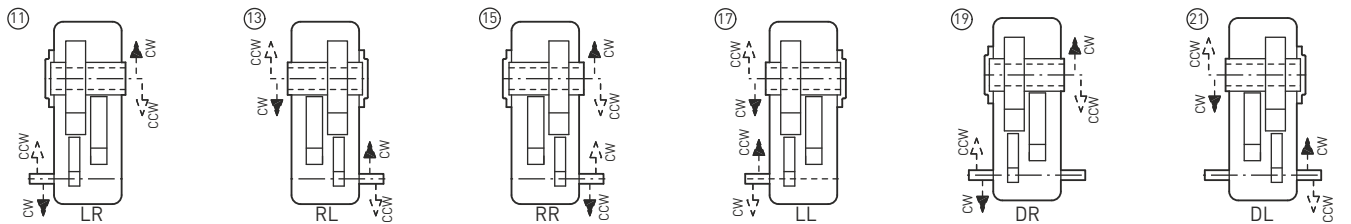
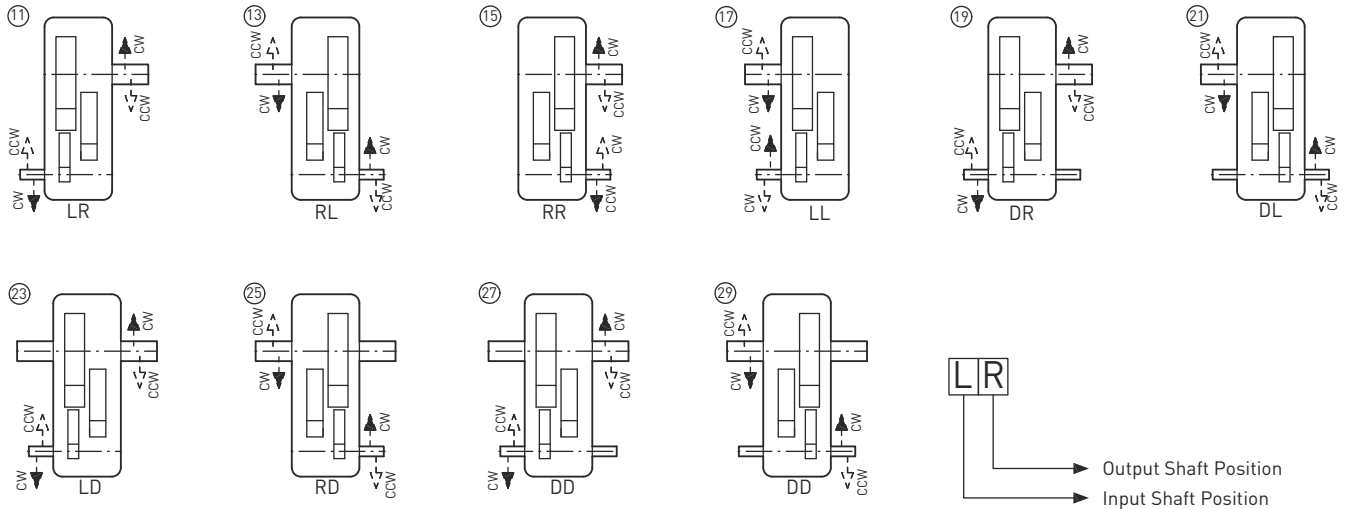

Helical Gear Unit

Shaft Arrangement - Hold Back

Type - S3
Triple Stage

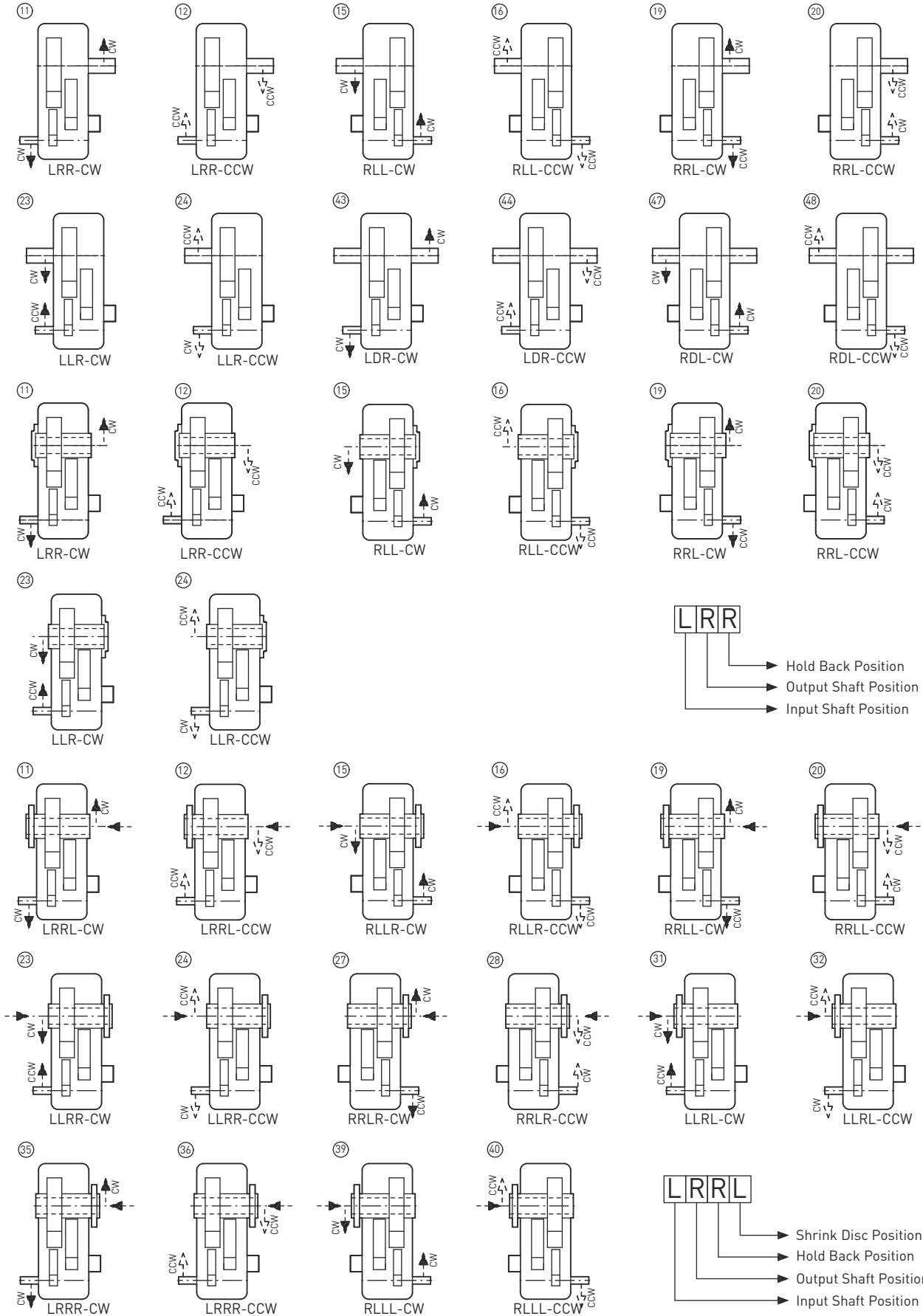

type - S4H

Quadruple Stage
Size 18 to 26

Horizontal Mounting

Helical Gear Unit

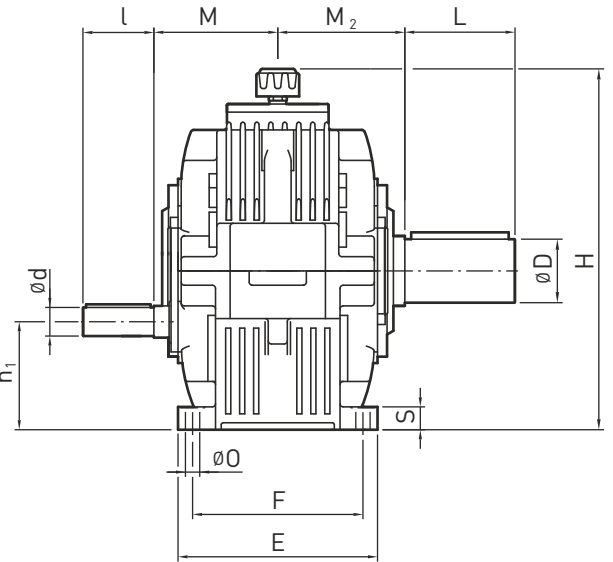
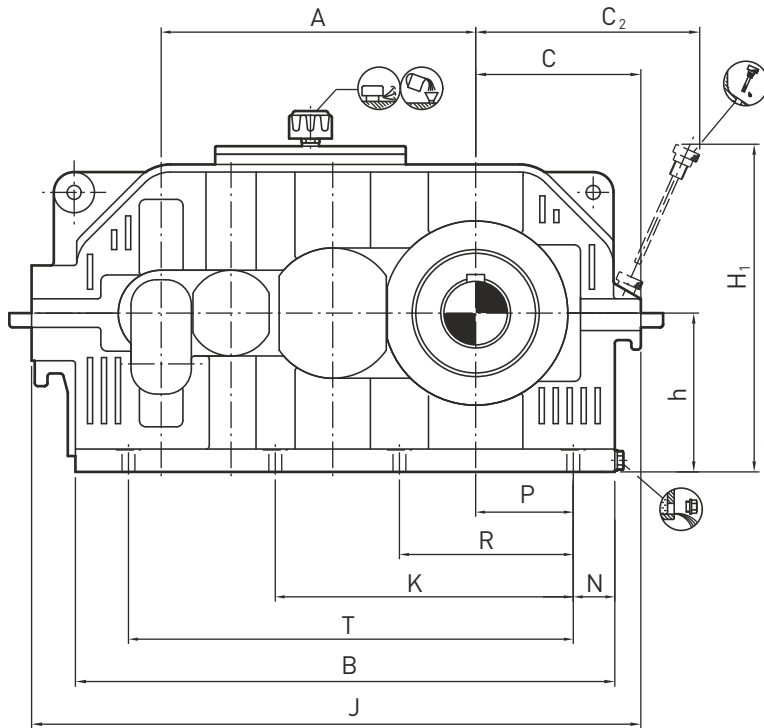

*For other shaft options refer page 60 to 64.

Size	Input Shaft						Output Shaft			Backstop			Average Weight [kg]	Oil Quantity [Litres]
	i = 90 - 225		i = 250 - 450		M	h ₁	D	L	M ₂	A ₁	d ₁ ¹⁾	Y ¹⁾		
	d	l	d	l										
S4..18	20	50	19	50	170	137	80	160	170	395	95	255	215	13
S4..19	20	50	19	50	180	154	90	165	180	440	95	255	300	18
S4..20	20	50	20	50	190	170	100	200	200	495	95	255	405	22
S4..21	30	80	25	60	220	190	110	200	220	555	135	310	540	28
S4..22	35	80	25	60	230	215	120	210	230	620	135	310	720	39
S4..23	40	110	35	80	260	245	140	250	260	700	140	310	970	56
S4..24	40	110	40	110	295	275	160	290	295	785	175	415	1300	80
S4..25	45	110	45	110	305	310	170	300	305	880	175	415	1770	115
S4..26	50	110	50	110	345	340	190	350	345	990	190	415	2350	165

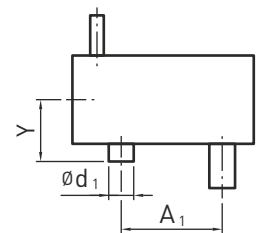

Size	Foundation																
	A	B	C	C ₂ ¹⁾	E	F	h	H ₁ ²⁾	H ¹⁾	J	K	N	O	P	R	S	T
S4..18	395	671	215	281	284	230	200	404	490	766		43	18	135	240	32	565
S4..19	440	751	240	315	303	250	225	455	540	860		53	23	145	255	36	615
S4..20	495	849	260	345	314	270	250	496	590	959		54	23	165	290	36	705
S4..21	555	946	290	394	385	310	280	572	650	1068		64	27	180	315	45	780
S4..22	620	1060	325	429	400	340	315	635	720	1190		75	27	200	355	45	880
S4..23	700	1181	355	481	450	380	355	705	800	1327	655	87	33	220	405	55	985
S4..24	785	1324	390	541	515	410	400	795	890	1475	740	92	33	245	450	55	1110
S4..25	880	1496	440	591	535	460	450	865	990	1655	840	98	33	280	510	55	1245
S4..26	990	1686	490	659	600	510	500	954	1090	1870	940	108	39	315	575	65	1400

Modification of dimensions reserved.

Shaft ends with keys according to DIN 6885, part 1, Shape A.

Shaft centering according to DIN 332, shape DS (with thread)

Tolerance field for shaft ends ISO fit, up to Ø50 k6; over Ø50 m6.

1) Max. dimensions; details acc. to order related documents

2) Approximate values; exact values acc. to order related documents

Helical Gear Unit

Torque Arm Mounting

Type - S4T
Quadruple Stage
Size 18 to 26

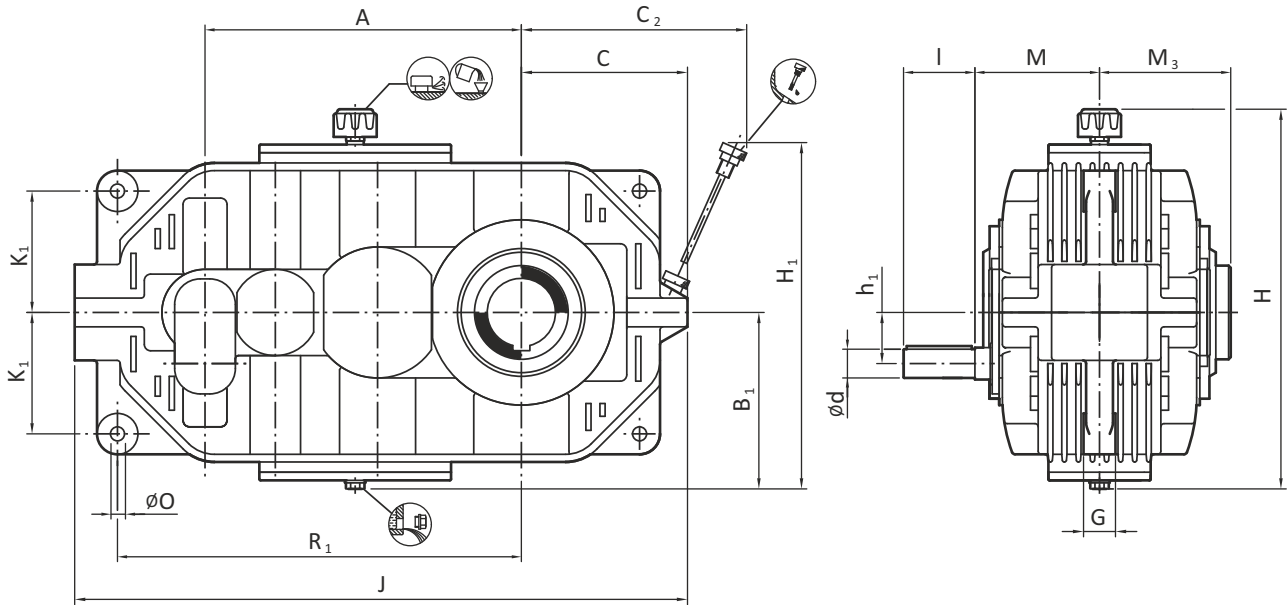

Size	Input Shaft						Output Shaft	Backstop			Average Weight [kg]	Oil Quantity [Litres]
	d	l	d	l	M	h ₁		A ₁	d ₁ ¹⁾	Y ¹⁾		
S4..18	20	50	19	50	170	63	170	395	95	255	190	7
S4..19	20	50	19	50	180	71	180	440	95	255	255	9
S4..20	20	50	20	50	190	80	190	495	95	255	345	11
S4..21	30	80	25	60	220	90	220	555	135	310	460	17
S4..22	35	80	25	60	230	100	230	620	135	310	610	23
S4..23	40	110	35	80	260	110	260	700	140	310	820	36
S4..24	40	110	40	110	295	125	295	785	175	415	1100	50
S4..25	45	110	45	110	305	140	305	880	175	415	1520	70
S4..26	50	110	50	110	345	160	345	990	190	415	2000	100

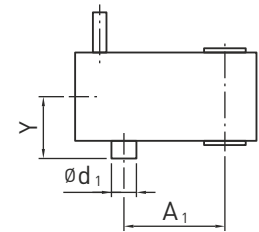

Size	Foundation										
	A	B ₁ ²⁾	C	C ₂ ¹⁾	G	H ²⁾	H ₁ ¹⁾	J	K ₁	O	R ₁
S4..18	395	230	215	281	35	520	434	766	145	24	500
S4..19	440	255	240	315	45	570	485	860	170	24	560
S4..20	495	280	260	345	50	620	526	959	190	28	632
S4..21	555	310	290	394	55	680	602	1068	222	28	710
S4..22	620	345	325	429	60	750	665	1190	255	36	790
S4..23	700	385	355	481	70	830	735	1327	290	40	882
S4..24	785	430	390	541	80	920	825	1475	325	48	985
S4..25	880	480	440	591	90	1020	895	1655	370	48	1115
S4..26	990	530	490	659	105	1120	984	1870	415	55	1265

Modification of dimensions reserved.

Shaft ends with keys according to DIN 6885, part 1, Shape A.
Shaft centering according to DIN 332, shape DS (with thread)

Tolerance field for shaft ends ISO fit, up to Ø50 k6; over Ø50 m6.

1) Max. dimensions; details acc. to order related documents

2) Approximate values; exact values acc. to order related documents

type - ۵۴
Quadruple Stage

Shaft Arrangement

Helical Gear Unit

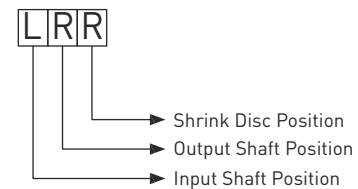
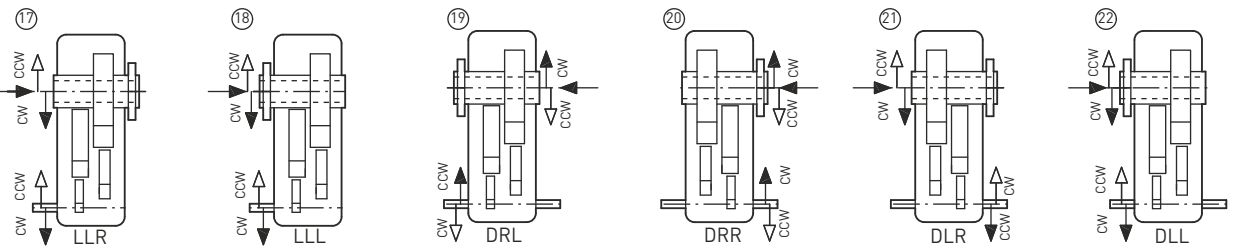
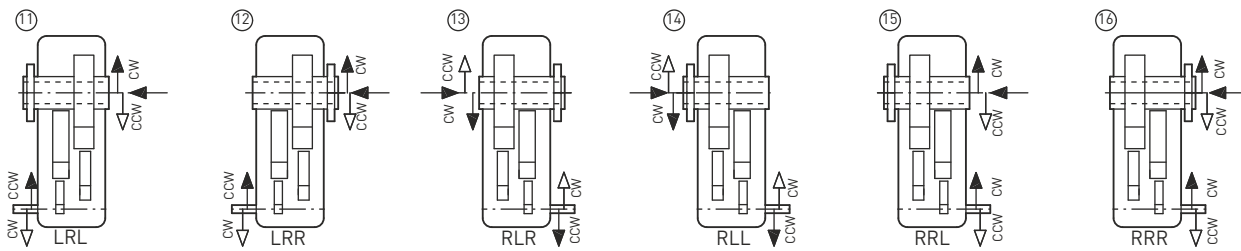
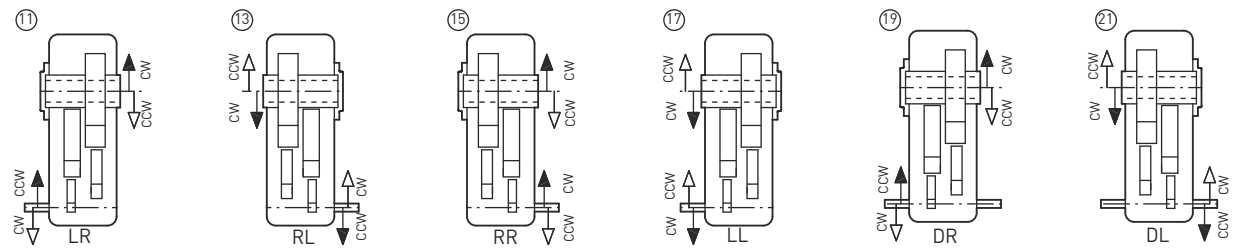
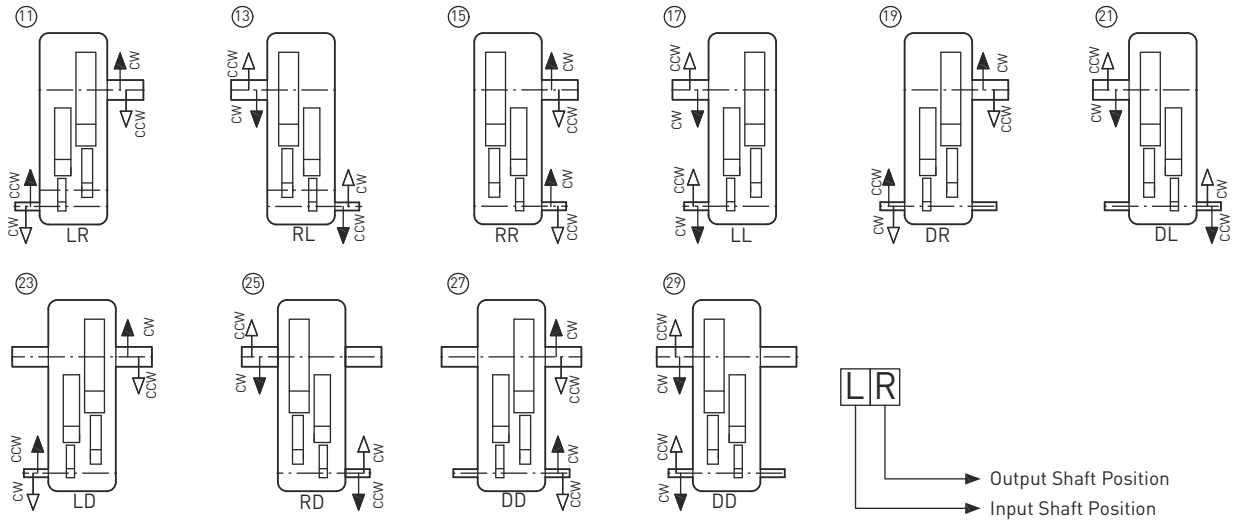

Helical Gear Unit

Shaft Arrangement - Hold Back

Type - S4
 Quadruple Stage

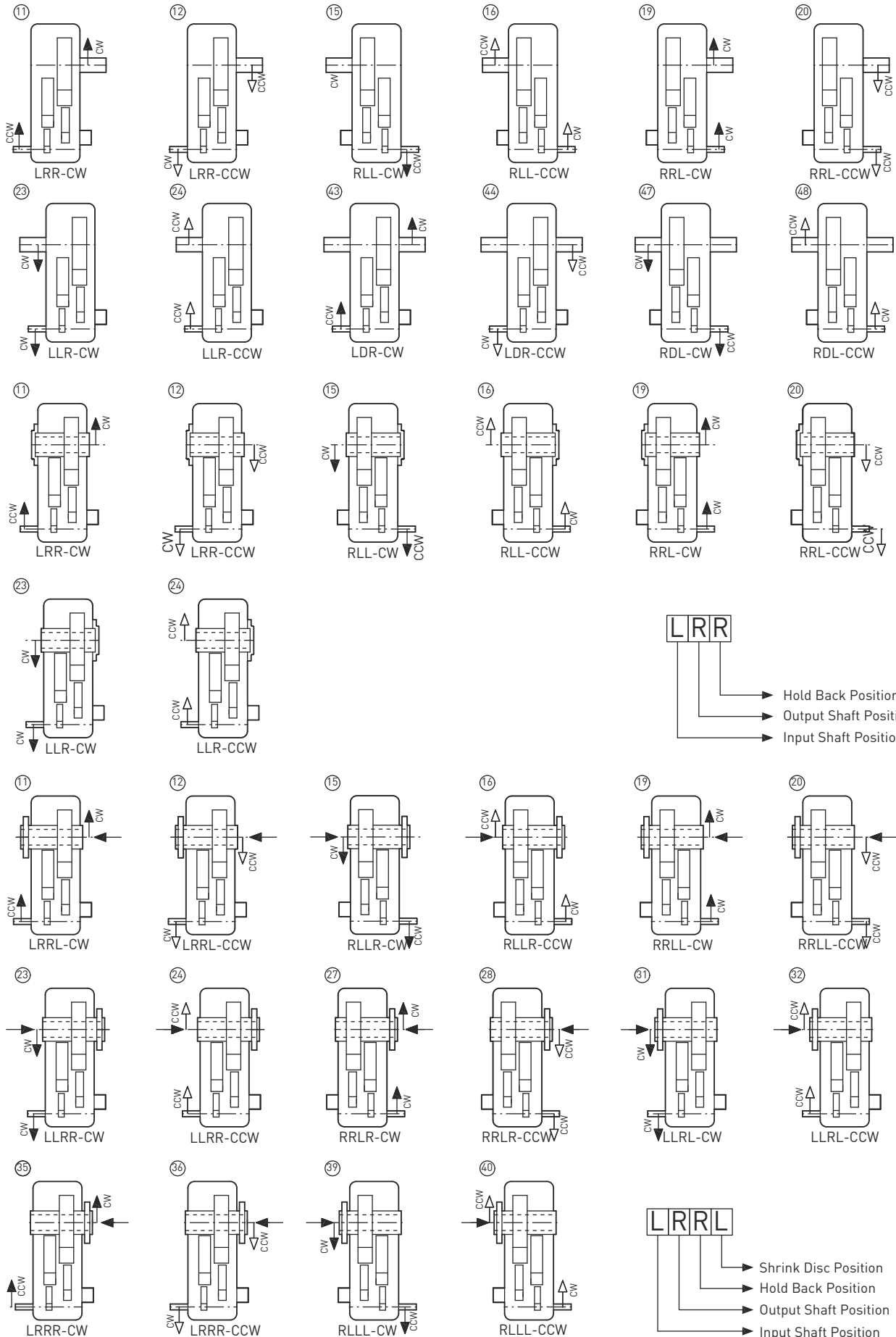

type - K2H

Double Stage
Size 11 to 18

Horizontal Mounting

Bevel Helical Gear Unit

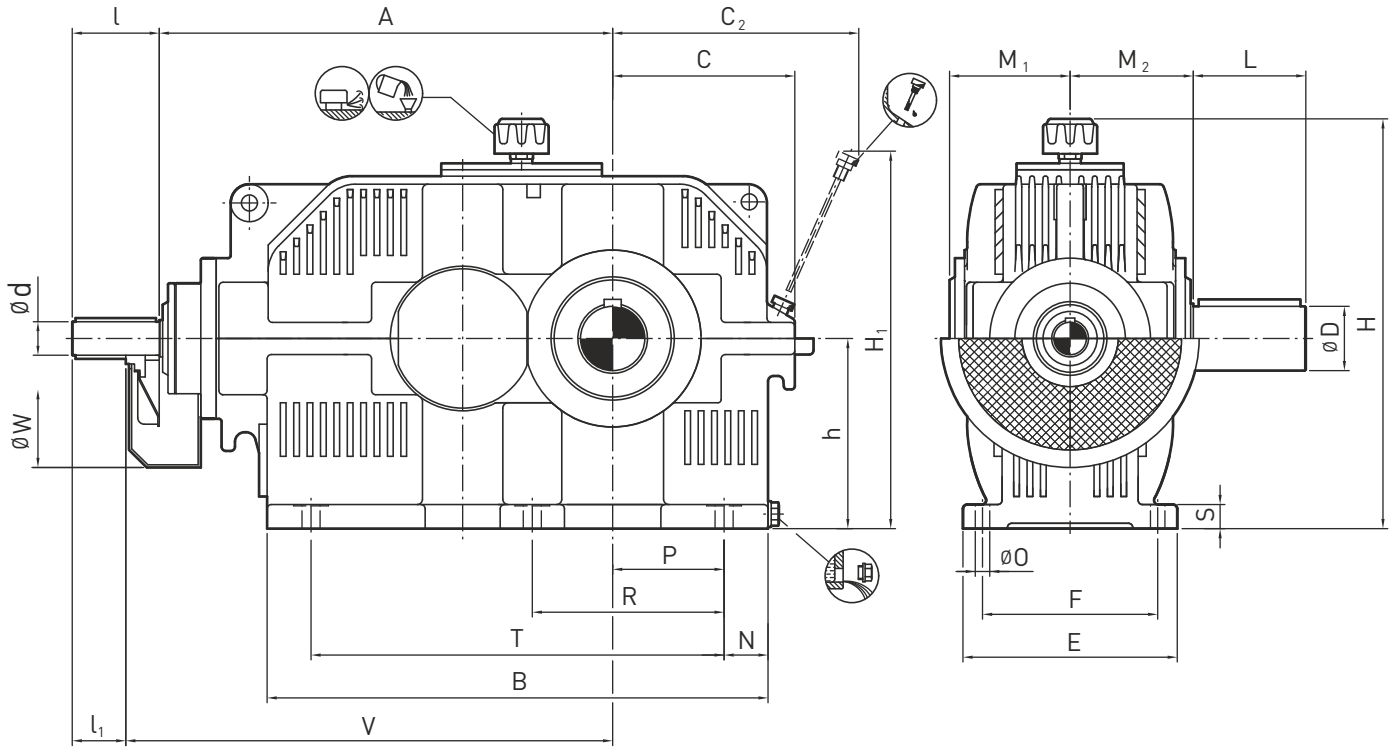

*For other shaft options refer page 60 to 64.

Size	Input Shaft						V	W	Output Shaft				Backstop		Average Weight [kg]	Oil Quantity [Litres]	
	i = 5-12.5			i = 14-18					D	L	M ₁	M ₂	A ₁	d ₁ ¹⁾			Y ¹⁾
	d	l	l ₁	d	l	l ₁											
K2..11	19	90	40	19	90	40	325	210	32	55	94	105	80	95	180	29	1.5
K2..13	24	100	50	24	100	50	390	270	45	95	106	115	100	105	190	52.5	2.5
K2..15	32	110	60	28	100	50	465	300	55	95	127	135	125	140	255	95	5
K2..17	42	130	80	38	110	60	570	360	70	135	141	150	160	175	255	174	8.5
K2..18	48	130	80	42	130	80	635	360	80	160	158	170	180	190	305	230	14

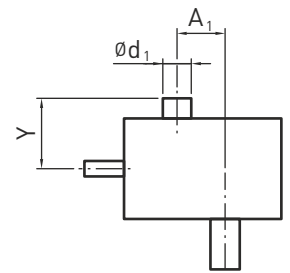

Size	Foundation														
	A	B	C	C ₂ ¹⁾	E	F	h	H ₁ ¹⁾	H ₂ ²⁾	N	O	P	R	S	T
K2..11	275	268	115	171	180	150	100	248	290	46	14	50	95	24	185
K2..13	340	349	135	195	190	150	125	295	340	47	14	65	120	24	270
K2..15	415	432	165	231	228	170	160	352	410	43	14	95	170	24	355
K2..17	520	536	205	282	250	210	200	432	480	53	18	115	210	32	440
K2..18	585	600	220	311	284	230	225	475	525	53	18	135	240	32	505

Modification of dimensions reserved.

Shaft ends with keys according to DIN 6885, part 1, Shape A.

Shaft centering according to DIN 332, shape DS (with thread)

Tolerance field for shaft ends ISO fit, up to Ø50 k6; over Ø50 m6.

1) Max. dimensions; details acc. to order related documents

2) Approximate values; exact values acc. to order related documents

Bevel Helical Gear Unit

Horizontal Mounting

Type - K2H

Double Stage
Size 20 to 26

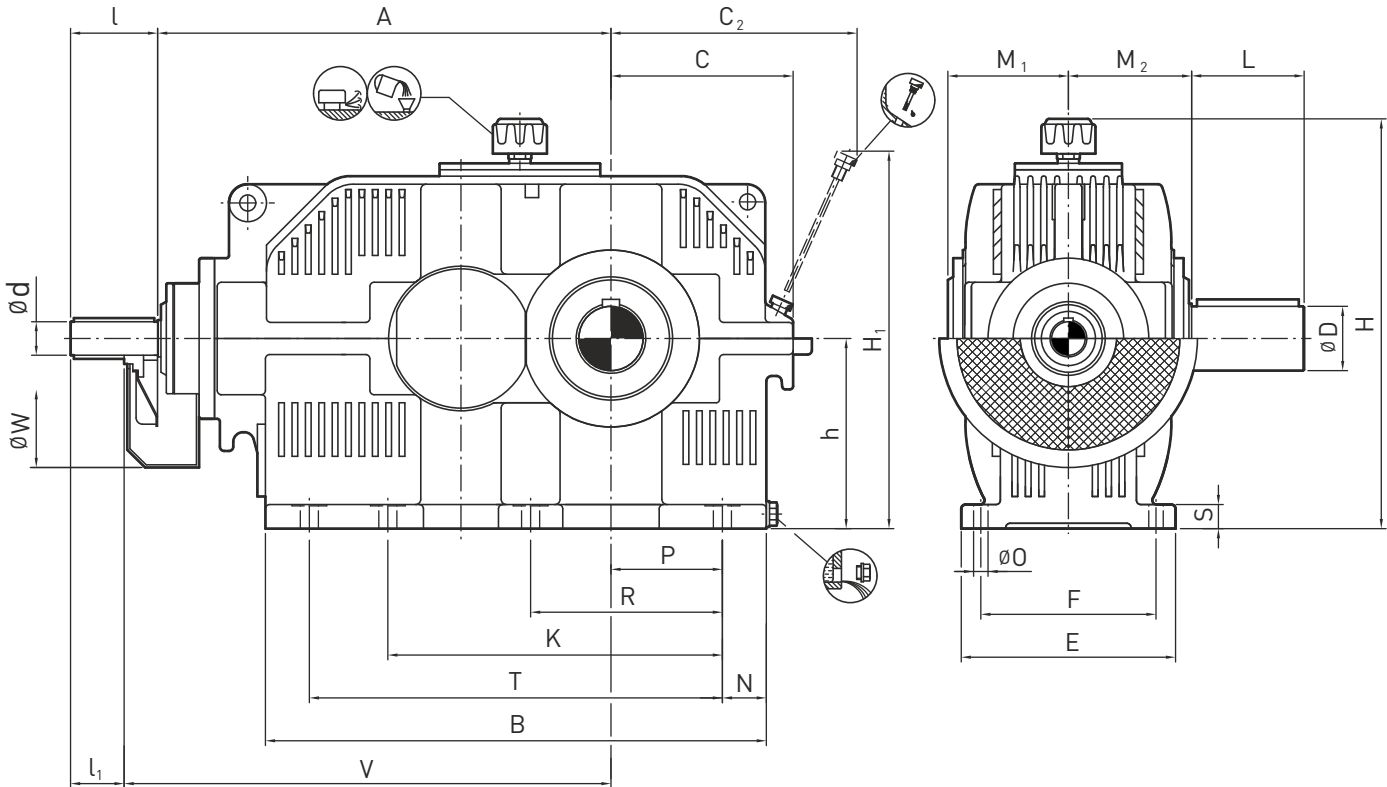

*For other shaft options refer page 60 to 64.

Size	Input Shaft						Output Shaft				Backstop			Average Weight [kg]	Oil Quantity [Litres]		
	i = 5-12.5			i = 14-18			D	L	M ₁	M ₂	A ₁	d ₁ ¹⁾	Y ¹⁾				
	d	l	l ₁	d	l	l ₁											
K2..20	58	135	85	52	130	80	770	460	100	200	176	200	225	210	305	415	24
K2..21	65	155	105	65	155	105	840	530	110	200	210	220	250	245	390	557	35
K2..22	70	155	105	70	155	105	925	550	120	210	220	230	280	290	390	756	48
K2..23	85	180	130	80	180	130	1025	550	140	250	234	260	315	290	390	1020	60
K2..24	90	180	130	90	180	130	1135	650	160	290	283	295	355	310	470	1370	110
K2..25	100	220	170	100	220	170	1265	700	170	300	293	305	400	310	470	1855	125
K2..26	110	220	170	110	220	170	1415	700	190	350	306	345	450	400	470	2500	160

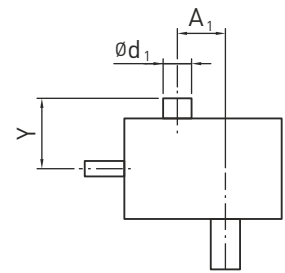

Size	Foundation															
	A	B	C	C ₂ ¹⁾	E	F	h	H ₁ ¹⁾	H ₂ ²⁾	K	N	O	P	R	S	T
K2..20	720	755	275	387	314	270	280	588	620		69	23	165	290	36	635
K2..21	790	843	305	435	385	310	315	664	685		79	27	180	315	45	705
K2..22	875	935	340	474	400	340	355	741	760		90	27	200	355	45	785
K2..23	975	1054	375	537	450	380	400	831	845		107	33	220	405	55	875
K2..24	1085	1169	425	598	515	410	450	908	940		122	33	245	450	55	975
K2..25	1215	1311	475	670	535	460	500	1013	1040		133	33	280	510	55	1105
K2..26	1365	1476	535	753	600	510	560	1137	1150	940	148	39	315	575	65	1245

Modification of dimensions reserved.

Shaft ends with keys according to DIN 6885, part 1, Shape A.

Shaft centering according to DIN 332, shape DS (with thread)

Tolerance field for shaft ends ISO fit, up to Ø50 k6; over Ø50 m6.

1) Max. dimensions; details acc. to order related documents

2) Approximate values; exact values acc. to order related documents

type - K2T
Double Stage
Size 11 to 18

Torque Arm Mounting

Bevel Helical Gear Unit

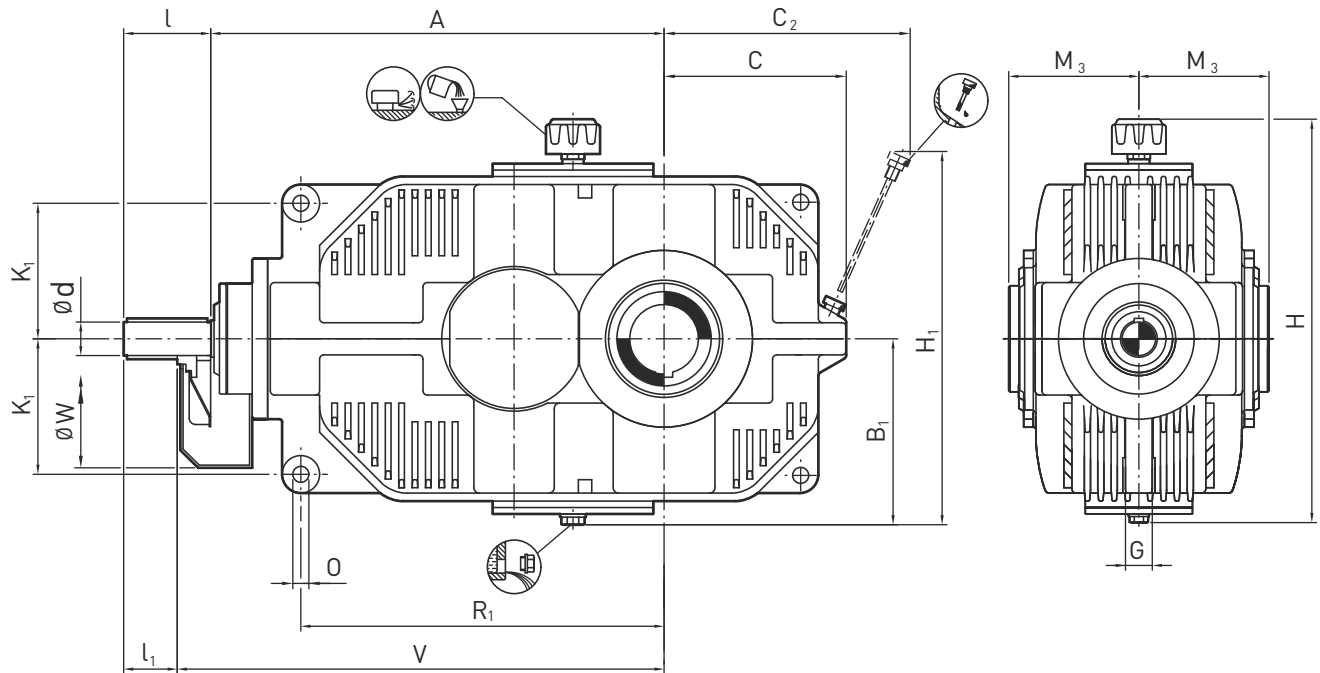

Size	Input Shaft						V	W	M ₃	Backstop			Average Weight [kg]	Oil Quantity [Litres]
	i = 5-12.5			i = 14-18						A ₁	d ₁ ¹⁾	Y ¹⁾		
	d	l	l ₁	d	l	l ₁								
K2..11	19	90	40	19	90	40	325	210	105	80	95	180	25	1
K2..13	24	100	50	24	100	50	390	270	115	100	105	190	44	2
K2..15	32	110	60	28	100	50	465	300	135	125	140	255	84	4
K2..17	42	130	80	38	110	60	570	360	150	160	175	255	152	7
K2..18	48	130	80	42	130	80	635	360	170	180	190	305	200	12

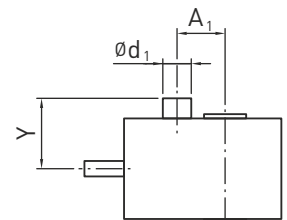

Size	Foundation									
	A	B ₁ ²⁾	C	C ₂ ¹⁾	G	H ₁ ¹⁾	H ²⁾	K ₁	O	R ₁
K2..11	275	130	115	171	20	278	320	66	10	192
K2..13	340	155	135	195	25	325	370	90	15	255
K2..15	415	190	165	231	28	382	440	120	18	316
K2..17	520	230	205	282	32	452	510	146	20	396
K2..18	585	255	220	311	35	505	555	156	24	445

Modification of dimensions reserved.

Shaft ends with keys according to DIN 6885, part 1, Shape A.

Shaft centering according to DIN 332, shape DS (with thread)

Tolerance field for shaft ends ISO fit, up to Ø50 k6; over Ø50 m6.

1) Max. dimensions; details acc. to order related documents

2) Approximate values; exact values acc. to order related documents

Bevel Helical Gear Unit

Torque Arm Mounting

Type - K2T

Double Stage
Size 20 to 26

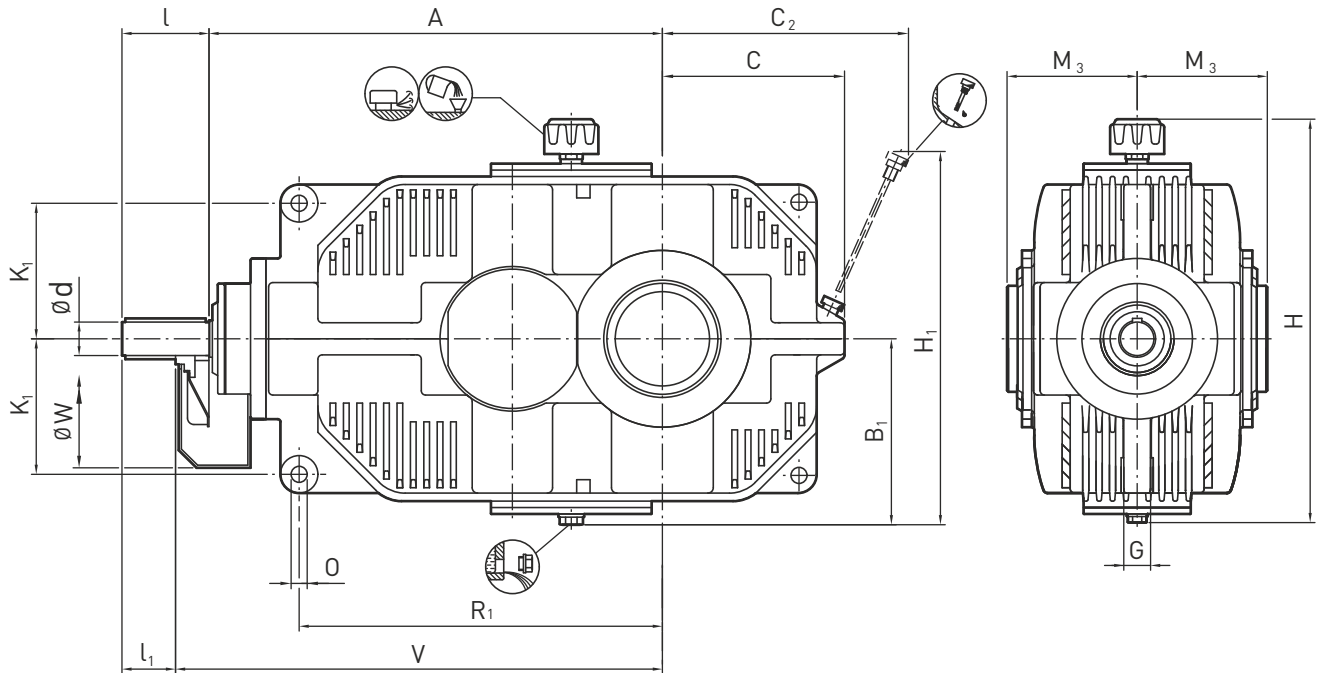

Size	Input Shaft						V	W	M ₃	Backstop			Average Weight [kg]	Oil Quantity [Litres]
	d	l	l ₁	d	l	l ₁				A ₁	d ₁ ¹⁾	Y ¹⁾		
K2..20	58	135	85	52	130	80	770	460	190	225	210	305	330	20
K2..21	65	155	105	65	155	105	840	530	220	250	245	390	460	30
K2..22	70	155	105	70	155	105	925	550	230	280	290	390	620	40
K2..23	85	180	130	80	180	130	1025	550	260	315	290	390	840	50
K2..24	90	180	130	90	180	130	1135	650	295	355	310	470	1130	95
K2..25	100	220	170	100	220	170	1265	700	305	400	310	470	1500	105
K2..26	110	220	170	110	220	170	1415	700	345	450	400	470	2000	135

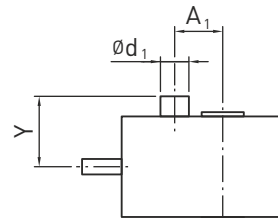

Size	Foundation									
	A	B ₁ ²⁾	C	C ₂ ¹⁾	G	H ₁ ¹⁾	H ²⁾	K ₁	O	R ₁
K2..20	720	310	275	387	50	618	650	192	28	550
K2..21	790	345	305	435	55	694	715	220	28	610
K2..22	875	385	340	474	60	771	790	255	36	670
K2..23	975	430	375	537	70	861	875	290	40	745
K2..24	1085	480	425	598	80	938	920	325	48	810
K2..25	1215	530	475	670	90	1043	1020	370	48	926
K2..26	1365	590	535	753	105	1167	1180	416	55	1040

Modification of dimensions reserved.

Shaft ends with keys according to DIN 6885, part 1, Shape A.

Shaft centering according to DIN 332, shape DS (with thread)

Tolerance field for shaft ends ISO fit, up to Ø50 k6; over Ø50 m6.

1) Max. dimensions; details acc. to order related documents

2) Approximate values; exact values acc. to order related documents

type - K2
Double Stage

Shaft Arrangement

Bevel Helical Gear Unit

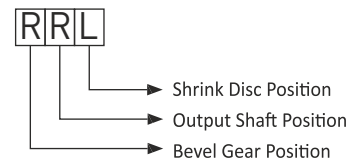
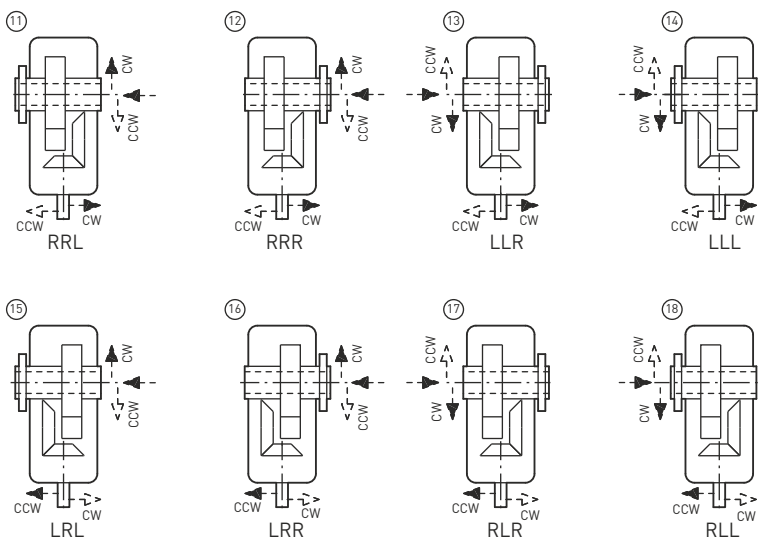
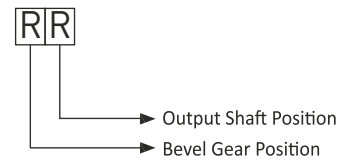
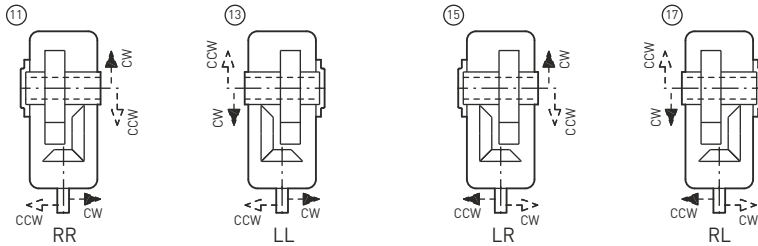
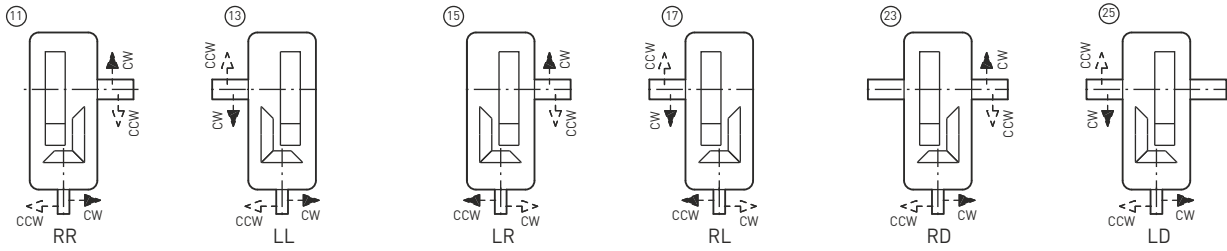

Bevel Helical Gear Unit

Shaft Arrangement - Int. Extension

Type - K2
Double Stage

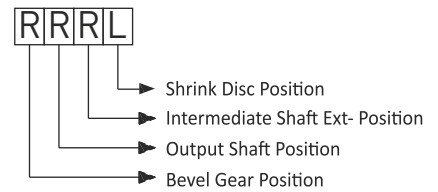
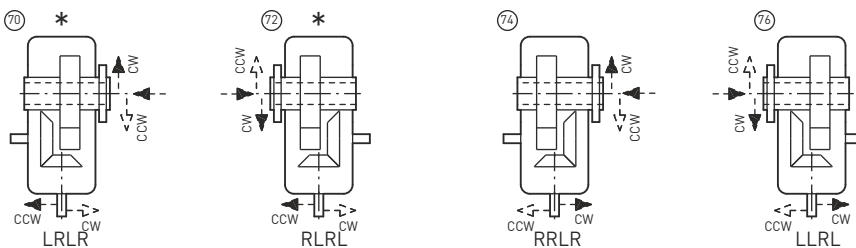
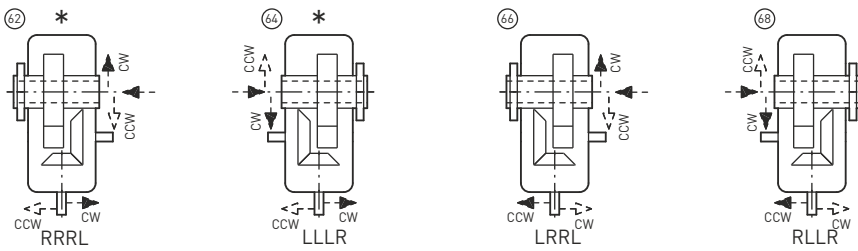
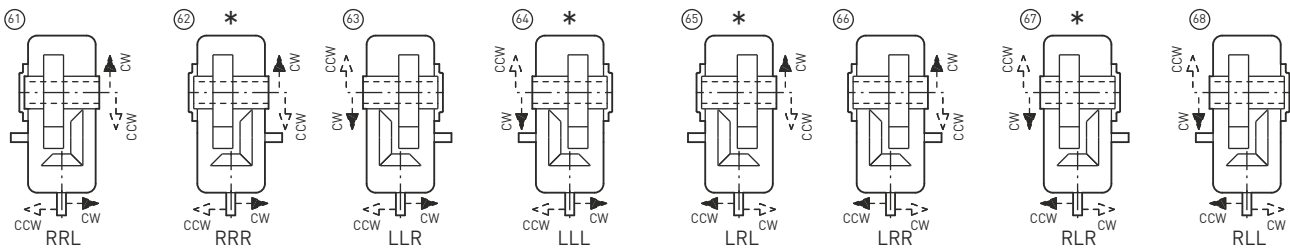
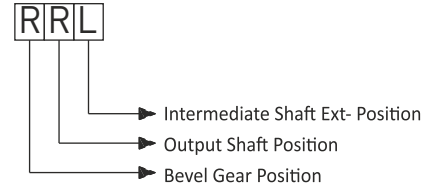
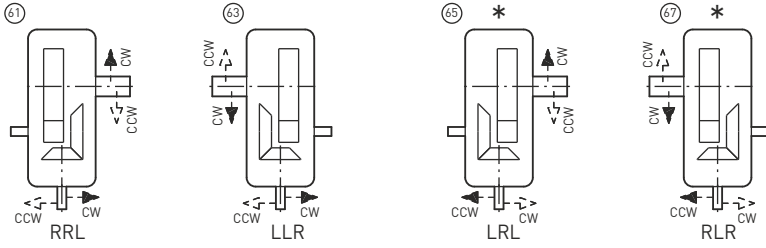

type - K2
Double Stage

Shaft Arrangement - Hold Back

Bevel Helical Gear Unit

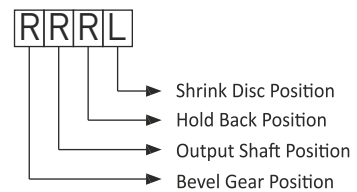
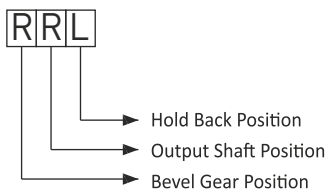
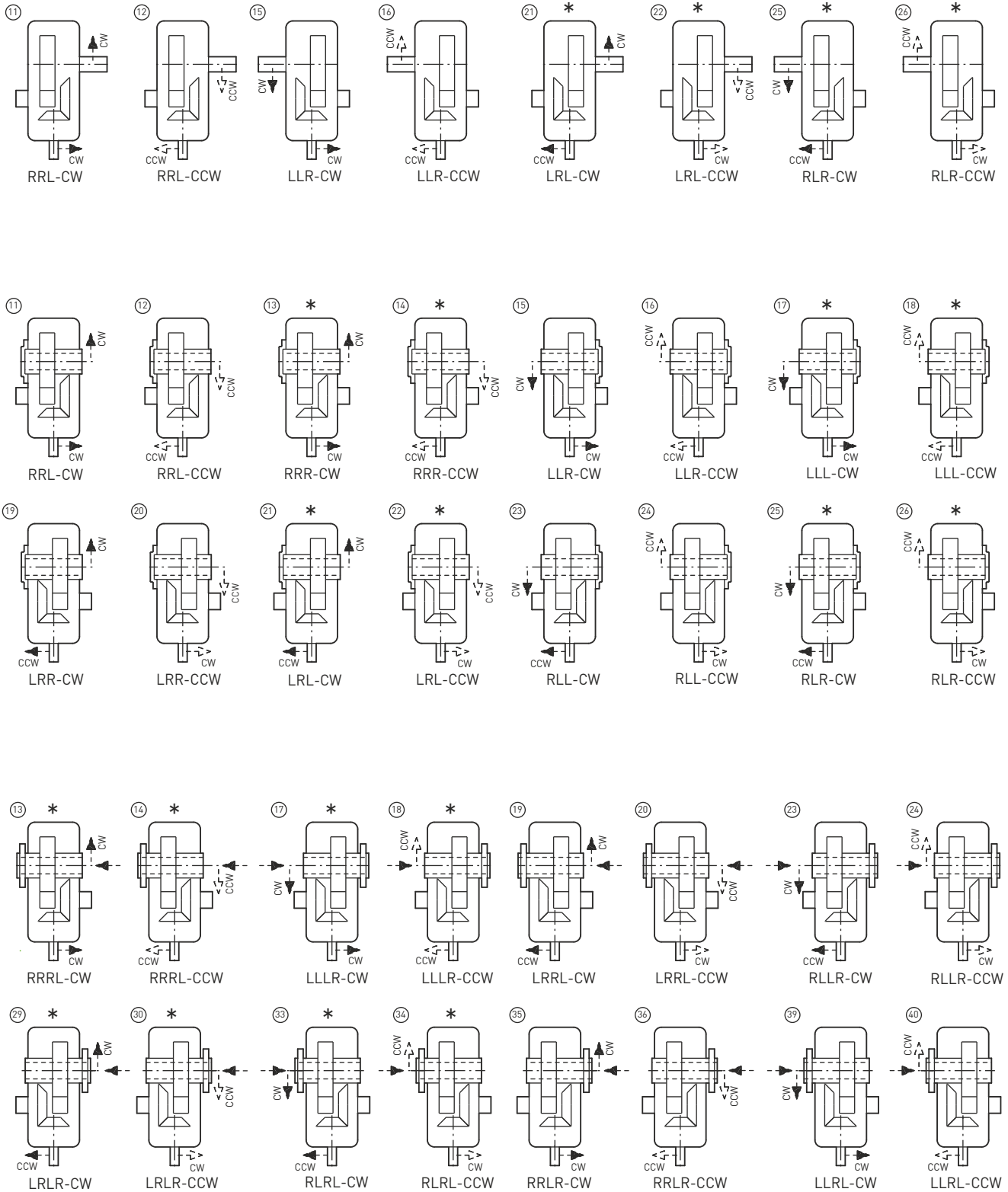

Bevel Helical Gear Unit

Shaft Arrangement - Int. Ext. & Hold Back

Type - K2
Double Stage

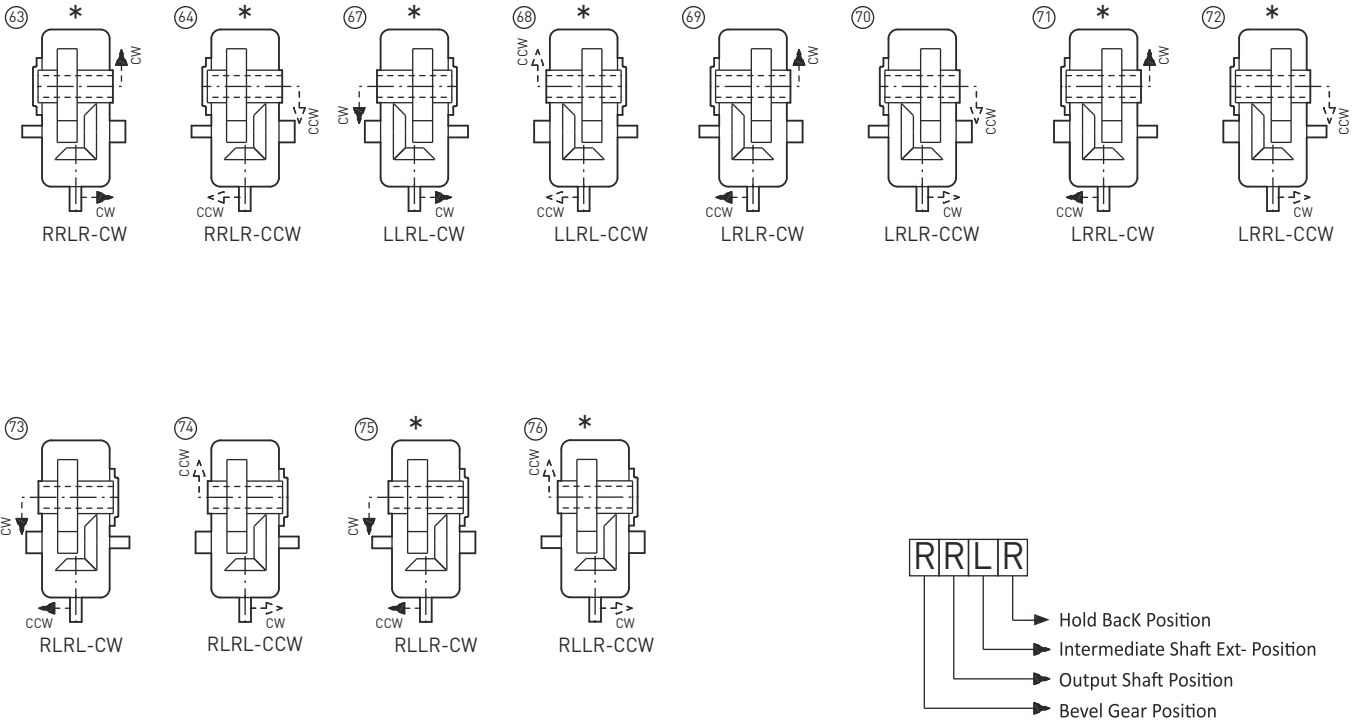

Type - K3H

Triple Stage
Size 14 to 18

Horizontal Mounting

Bevel Helical Gear Unit

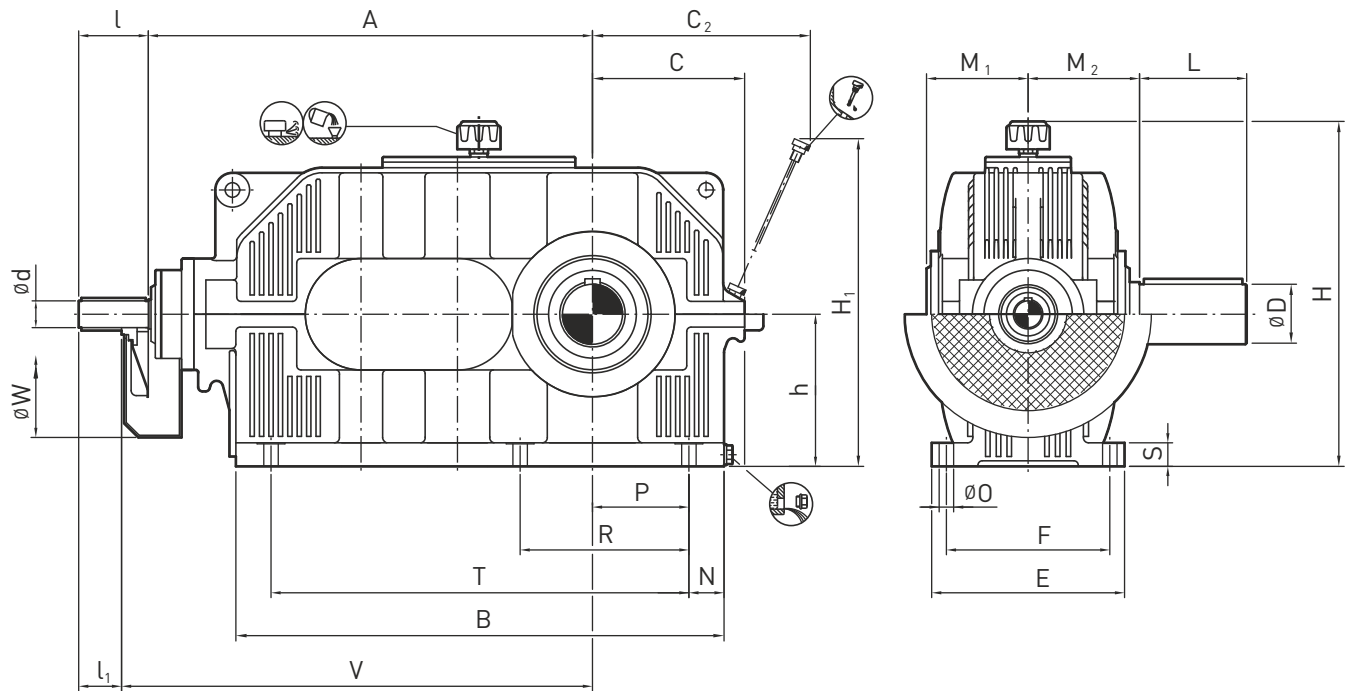

*For other shaft options refer page 60 to 64.

Size	Input Shaft						Output Shaft						Backstop			Average Weight [kg]	Oil Quantity [Litres]
	i = 20-50			i = 56-71			D	L	M ₁	M ₂	A ₁	d ₁ ¹⁾	Y ¹⁾				
	d	l	l ₁	d	l	l ₁								V	W		
K3..14	19	90	40	19	90	40	435	240	48	95	106	125	190	90	180	70	3.5
K3..15	24	100	50	24	100	50	470	270	55	95	127	135	215	95	215	95	4.5
K3..16	24	100	50	24	100	50	530	300	60	130	133	145	240	95	215	130	6.5
K3..17	28	100	50	24	100	50	580	340	70	135	141	150	270	95	215	175	9
K3..18	32	110	60	28	100	50	645	360	80	160	158	170	305	140	265	235	13

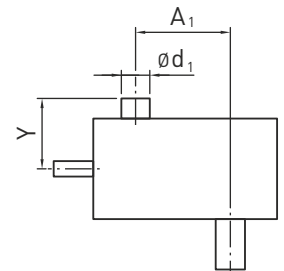

Size	Foundation														
	A	B	C	C ₂ ¹⁾	E	F	h	H ₁ ¹⁾	H ₂ ²⁾	N	O	P	R	S	T
K3..14	385	400	140	194	190	150	125	278	340	38	14	80	140	24	345
K3..15	420	460	155	215	228	170	140	306	370	38	14	95	170	24	395
K3..16	480	521	175	231	233	190	160	327	410	38	14	110	195	24	450
K3..17	530	580	190	257	250	210	180	378	450	43	18	115	210	32	495
K3..18	595	648	215	281	284	230	200	404	490	43	18	135	240	32	565

Modification of dimensions reserved.

Shaft ends with keys according to DIN 6885, part 1, Shape A.

Shaft centering according to DIN 332, shape DS (with thread)

Tolerance field for shaft ends ISO fit, up to Ø50 k6; over Ø50 m6.

1) Max. dimensions; details acc. to order related documents

2) Approximate values; exact values acc. to order related documents

Bevel Helical Gear Unit

Horizontal Mounting

Type - K3H

Triple Stage
Size 19 to 26

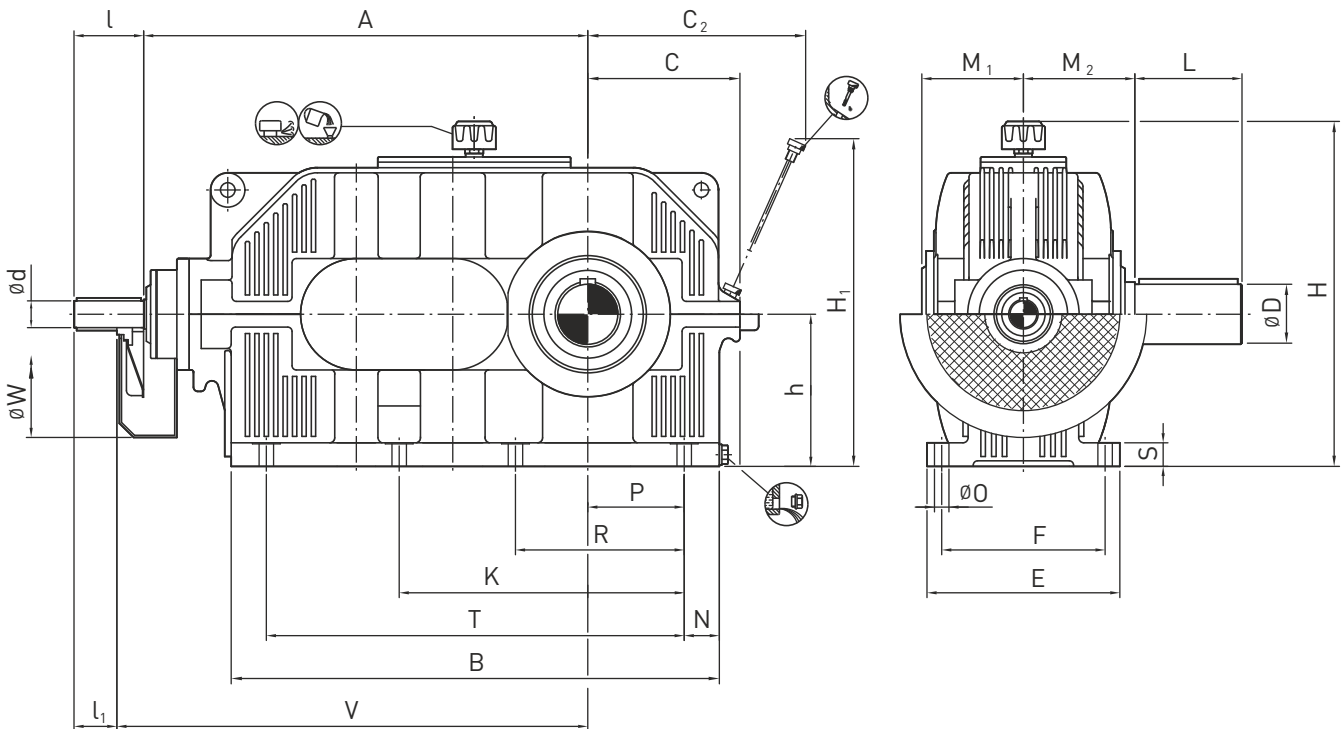

*For other shaft options refer page 60 to 64.

Size	i = 20-50 i = 22.4-63 i = 25-71			Input Shaft i = 56-71 i = 71-90 i = 80-100			Output Shaft				Backstop			Average Weight [kg]	Oil Quantity [Litres]		
	d	l	l ₁	d	l	l ₁	V	W	D	L	M ₁	M ₂	A ₁			d ₁ ¹⁾	Y ¹⁾
K3..19	38	110	60	32	110	60	710	360	90	165	171	180	340	150	265	320	18
K3..20	42	130	80	38	110	60	795	400	100	200	176	200	385	150	265	430	26
K3..21	48	130	80	42	130	80	885	460	110	200	210	220	430	190	340	580	33
K3..22	52	130	80	48	130	80	970	530	120	210	220	230	480	190	340	780	46
K3..23	58	135	85	52	130	80	1085	550	140	250	234	260	540	190	340	1060	65
K3..24	65	155	105	65	155	105	1195	600	160	290	283	295	605	245	440	1430	90
K3..25	70	155	105	70	155	105	1325	650	170	300	293	305	680	245	440	1930	125
K3..26	85	180	130	80	180	130	1475	700	190	350	306	345	765	245	440	2590	180

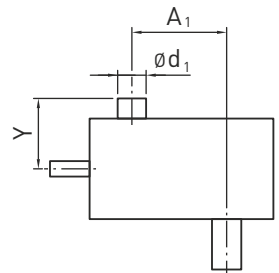

Size	Foundation															
	A	B	C	C ₂ ¹⁾	E	F	h	H ₁ ¹⁾	H ₂ ²⁾	K	N	O	P	R	S	T
K3..19	660	716	240	315	303	250	225	455	540		53	23	145	255	36	615
K3..20	745	807	260	345	314	270	250	496	590		54	23	165	290	36	705
K3..21	835	898	290	394	385	310	280	572	650		64	27	180	315	45	780
K3..22	920	1010	325	429	400	340	315	635	720		75	27	200	355	45	880
K3..23	1035	1139	355	481	450	380	355	705	800	655	87	33	220	405	55	985
K3..24	1145	1269	390	541	515	410	400	795	890	740	92	33	245	450	55	1110
K3..25	1275	1411	440	591	535	460	450	865	990	840	98	33	280	510	55	1245
K3..26	1425	1586	490	659	600	510	500	954	1090	940	108	39	315	575	65	1400

Modification of dimensions reserved.

Shaft ends with keys according to DIN 6885, part 1, Shape A.

Shaft centering according to DIN 332, shape DS (with thread)

Tolerance field for shaft ends ISO fit, up to Ø50 k6; over Ø50 m6.

1) Max. dimensions; details acc. to order related documents

2) Approximate values; exact values acc. to order related documents

Type - K3T

Triple Stage
Size 14 to 18

Torque Arm Mounting

Bevel Helical Gear Unit

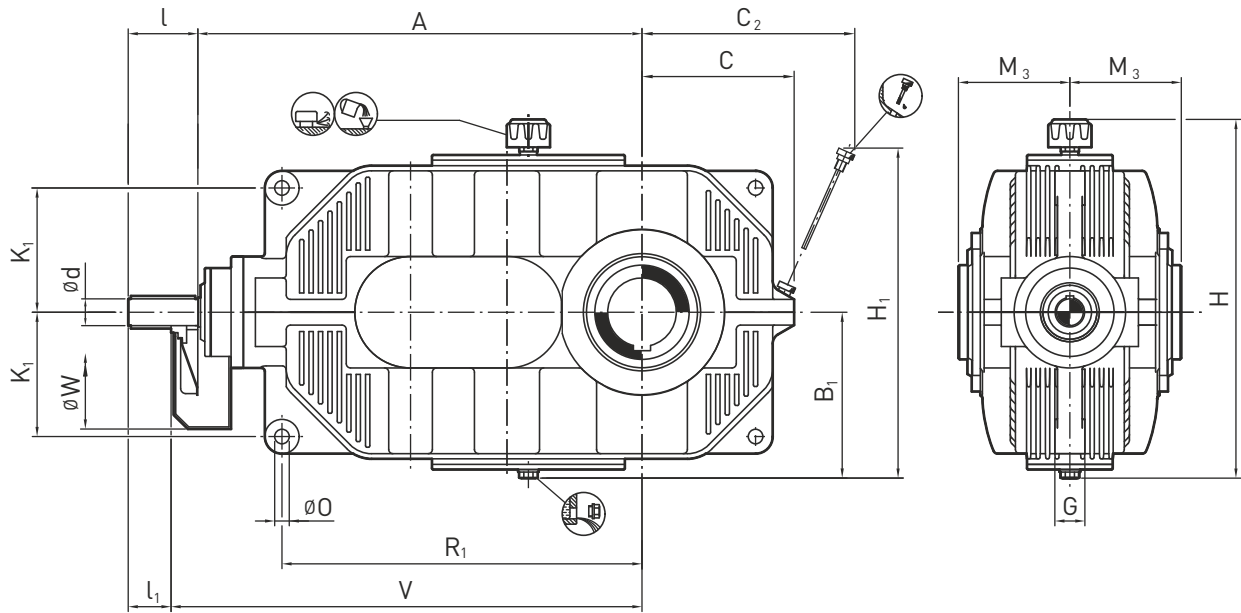

Size	i = 20-50			Input Shaft i = 56-71			V	W	Output Shaft M ₃	Backstop			Average Weight [kg]	Oil Quantity [Litres]
	d	l	l ₁	i = 71-90		l ₁				A ₁	d ₁ ¹⁾	Y ¹⁾		
				d	l									
K3..14	19	90	40	19	90	40	435	240	120	190	90	180	65	2
K3..15	24	100	50	24	100	50	470	270	135	215	95	215	85	3
K3..16	24	100	50	24	100	50	530	300	145	240	95	215	115	4
K3..17	28	100	50	24	100	50	580	340	150	270	95	215	150	6
K3..18	32	110	60	28	100	50	645	360	170	305	140	265	205	8

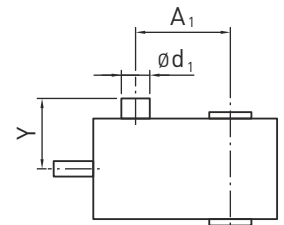

Size	Foundation									
	A	B ₁ ²⁾	C	C ₂ ¹⁾	G	H ₁ ¹⁾	H ²⁾	K ₁	O	R ₁
K3..14	385	155	140	194	25	308	370	90	18	300
K3..15	420	170	155	215	28	336	400	102	18	336
K3..16	480	190	175	231	30	357	440	115	20	380
K3..17	530	210	190	257	32	408	480	136	20	430
K3..18	595	230	215	281	35	434	520	146	24	478

Modification of dimensions reserved.

Shaft ends with keys according to DIN 6885, part 1, Shape A.

Shaft centering according to DIN 332, shape DS (with thread)

Tolerance field for shaft ends ISO fit, up to Ø50 k6; over Ø50 m6.

1) Max. dimensions; details acc. to order related documents

2) Approximate values; exact values acc. to order related documents

Bevel Helical Gear Unit

Torque Arm Mounting

Type - K3T

Triple Stage
Size 19 to 26

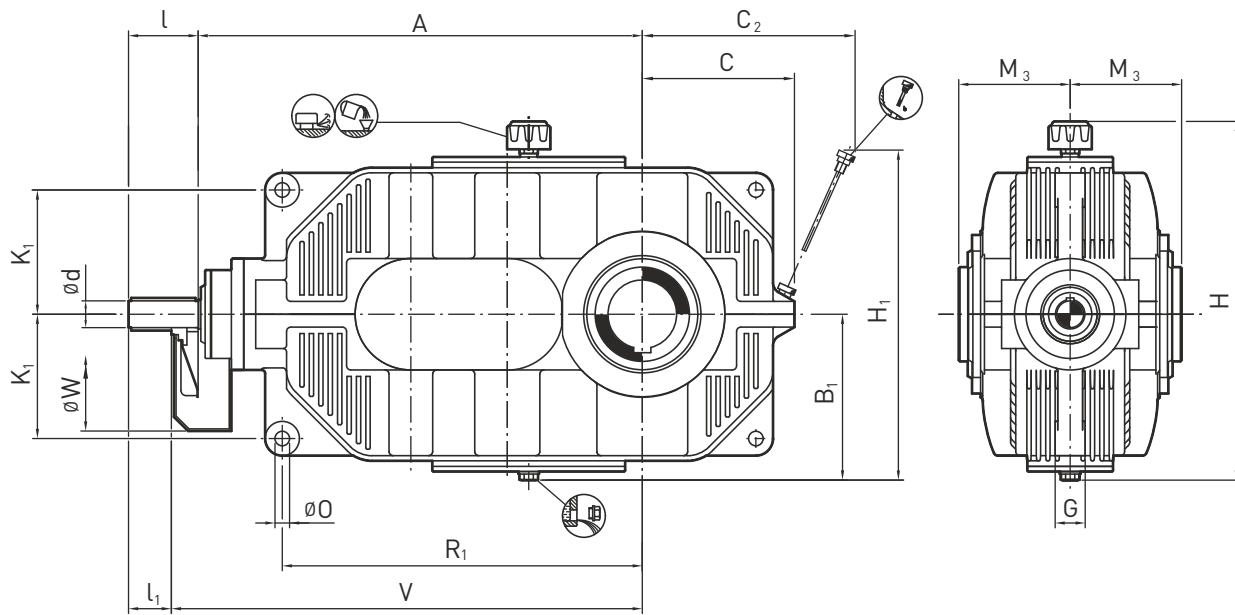

Size	i = 20-50			Input Shaft i = 56-71			V	W	Output Shaft M_3	Backstop			Average Weight [kg]	Oil Quantity [Litres]
	d	l	l_1	d	l	l_1				A ₁	$d_1^{1)}$	Y ¹⁾		
K3..19	38	110	60	32	110	60	710	360	180	340	150	265	280	12
K3..20	42	130	80	38	110	60	795	400	190	385	150	265	370	17
K3..21	48	130	80	42	130	80	885	460	220	430	190	340	500	21
K3..22	52	130	80	48	130	80	970	530	230	480	190	340	670	28
K3..23	58	135	85	52	130	80	1085	550	260	540	190	340	910	40
K3..24	65	155	105	65	155	105	1195	600	295	605	245	440	1170	55
K3..25	70	155	105	70	155	105	1325	650	305	680	245	440	1580	80
K3..26	85	180	130	80	180	130	1475	700	345	765	245	440	2070	115

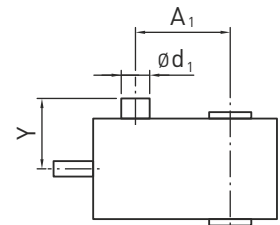

Size	Foundation									
	A	$B_1^{2)}$	C	$C_2^{1)}$	G	$H_1^{1)}$	$H^{2)}$	K_1	O	R_1
K3..19	660	255	240	315	45	485	570	170	24	525
K3..20	745	280	260	345	50	526	620	190	28	590
K3..21	835	310	290	394	55	602	680	220	28	660
K3..22	920	345	325	429	60	665	750	255	36	740
K3..23	1035	385	355	481	70	735	830	290	40	840
K3..24	1145	430	390	541	80	825	920	325	48	930
K3..25	1275	480	440	591	90	895	1020	370	48	1035
K3..26	1425	530	490	659	105	984	1120	415	55	1165

Modification of dimensions reserved.

Shaft ends with keys according to DIN 6885, part 1, Shape A.
Shaft centering according to DIN 332, shape DS (with thread)

Tolerance field for shaft ends ISO fit, up to $\phi 50$ k6; over $\phi 50$ m6.

1) Max. dimensions; details acc. to order related documents

2) Approximate values; exact values acc. to order related documents

Type - K3
Triple Stage

Shaft Arrangement

Bevel Helical Gear Unit

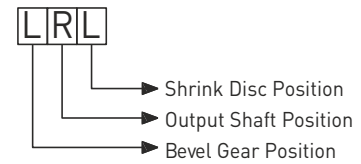
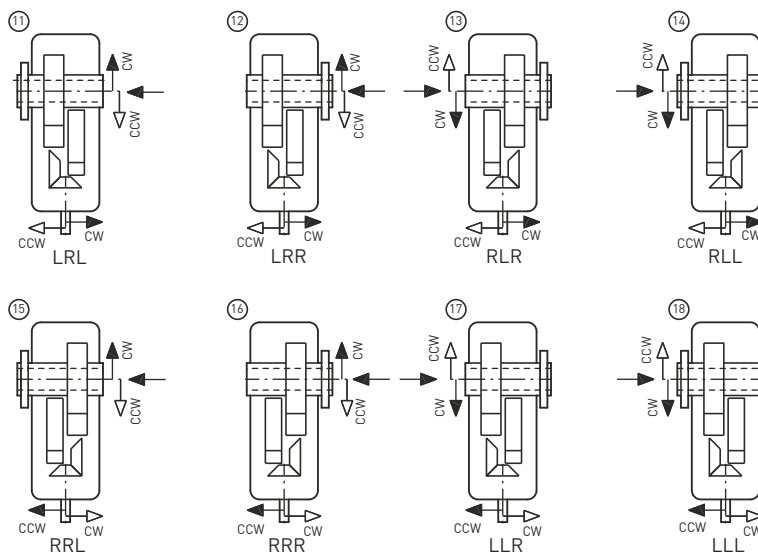
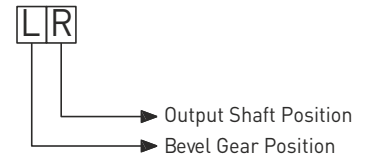
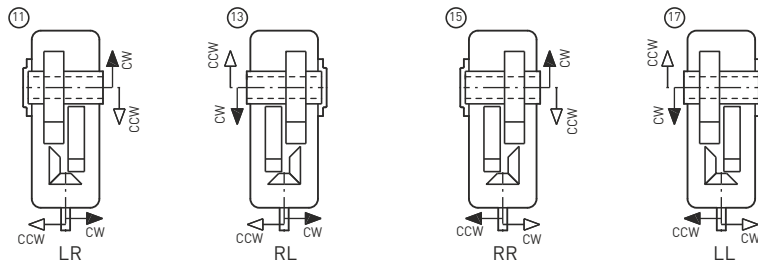
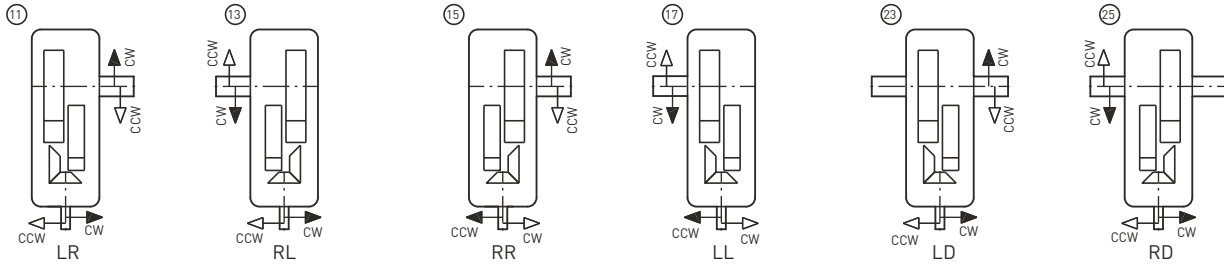

type - K3
Triple Stage

Shaft Arrangement - Hold Back

Bevel Helical Gear Unit

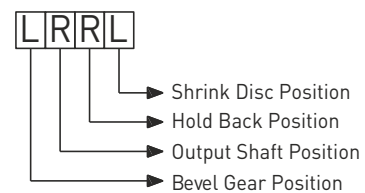
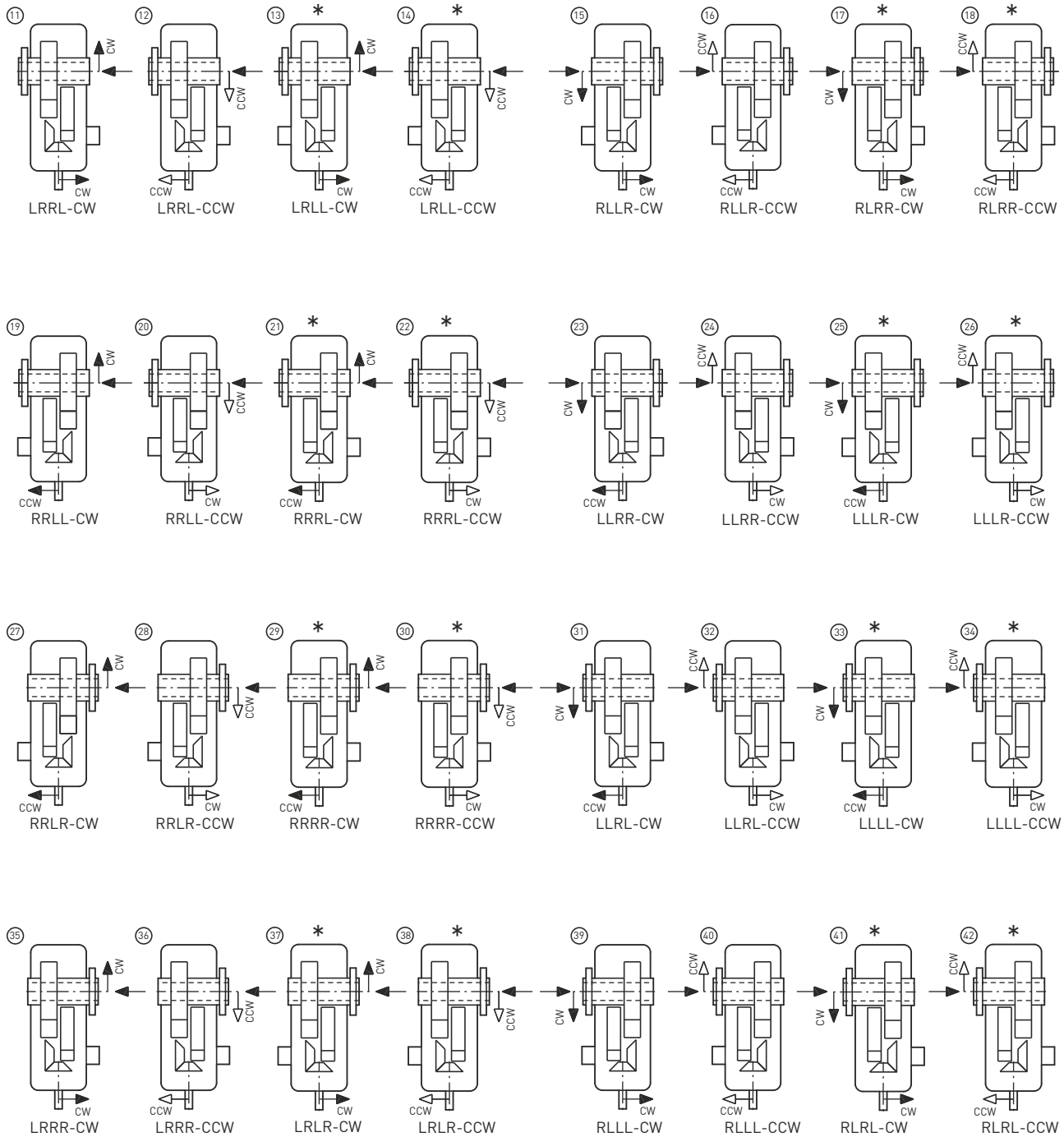

Bevel Helical Gear Unit

Shaft Arrangement - Hold Back

Type - K3
Triple Stage

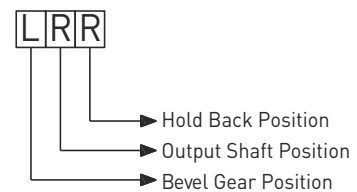
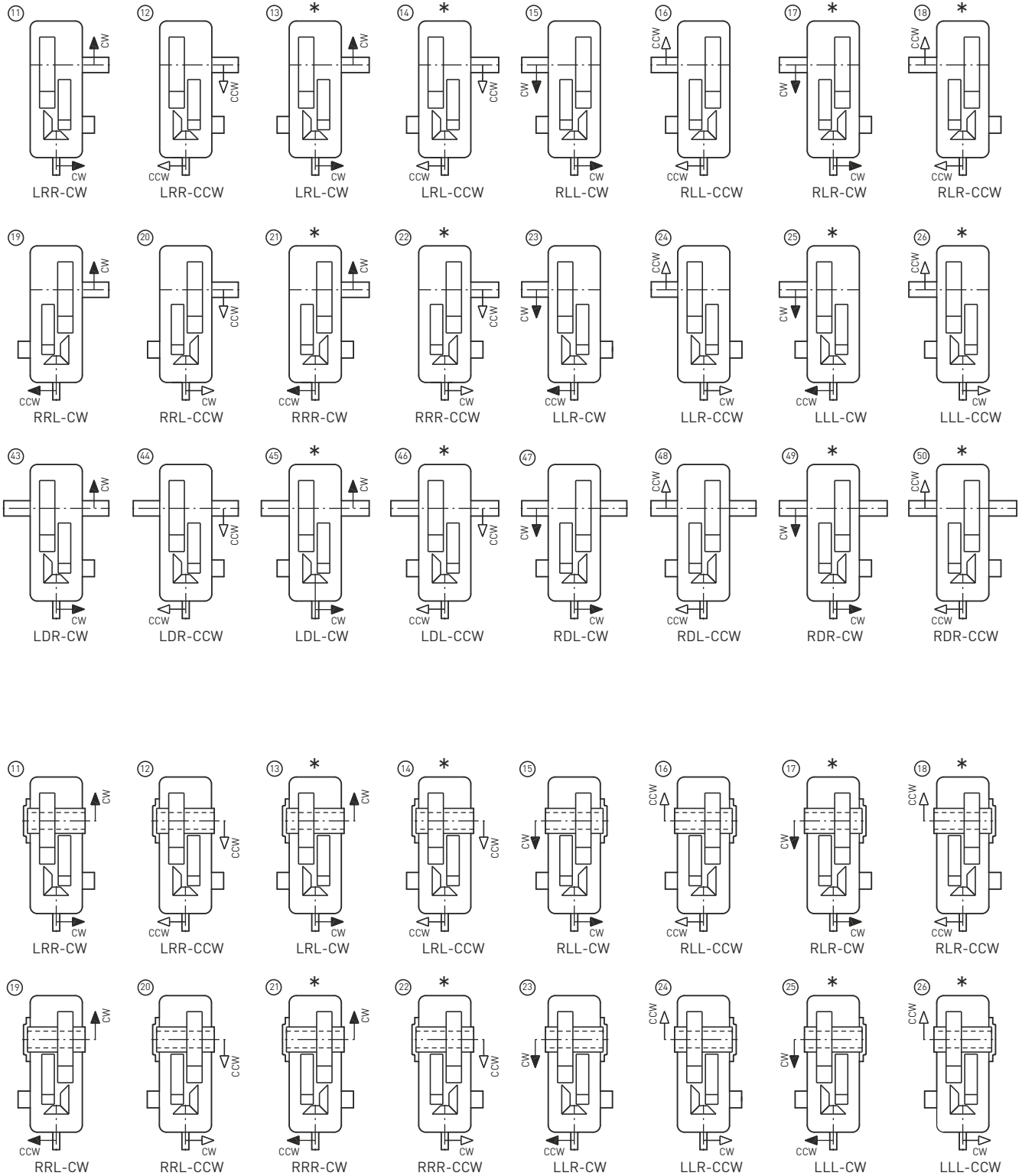

type - K3
Triple Stage

Shaft Arrangement-Int Ext & Hold Back

Bevel Helical Gear Unit

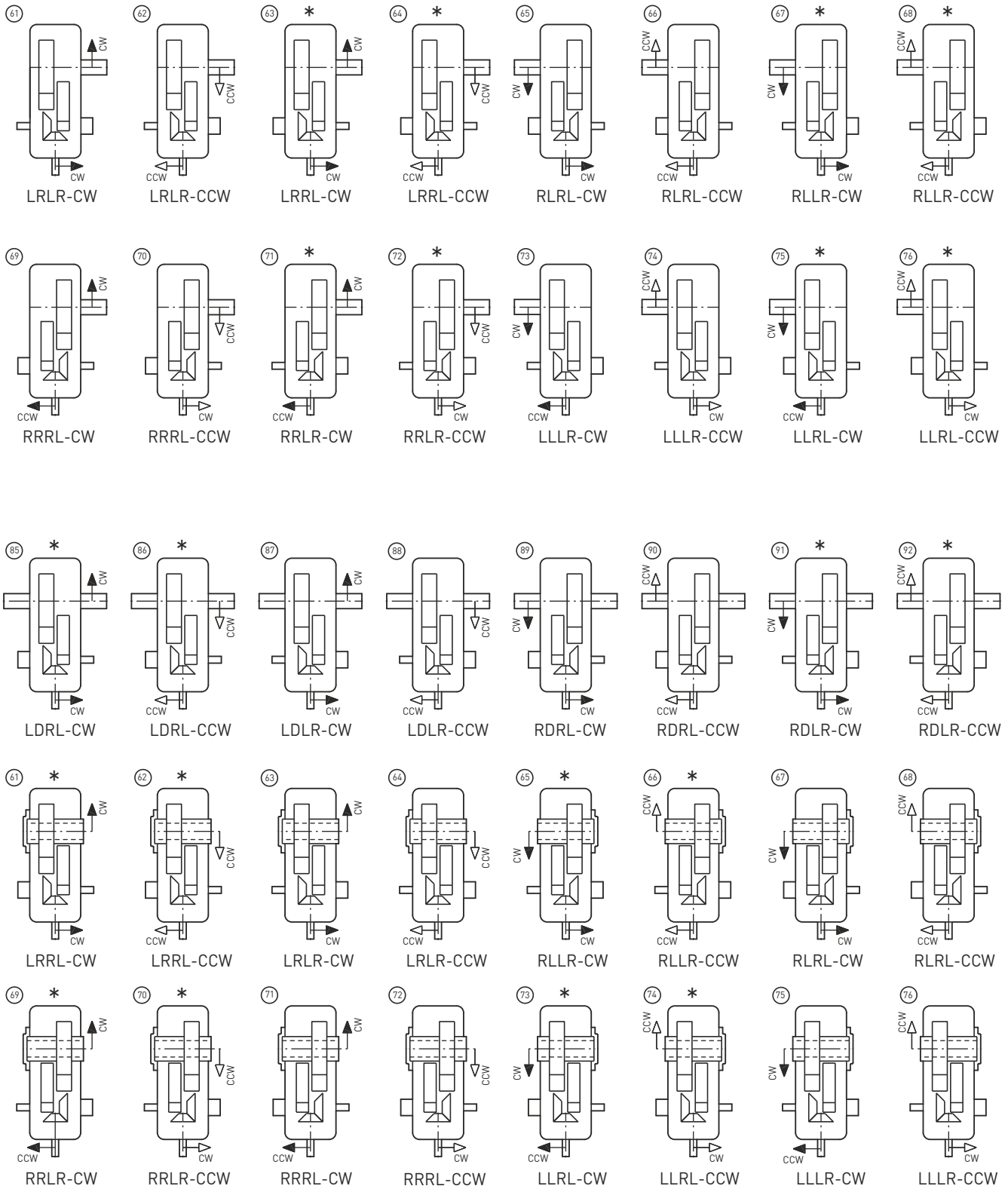

LRLR

- Hold Back Position
- Intermediate Shaft Ext- Position
- Output Shaft Position
- Bevel Gear Position

Bevel Helical Gear Unit

Shaft Arrangement-Int Ext & Hold Back

Type - K3

Triple Stage

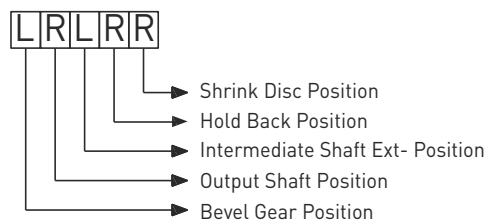
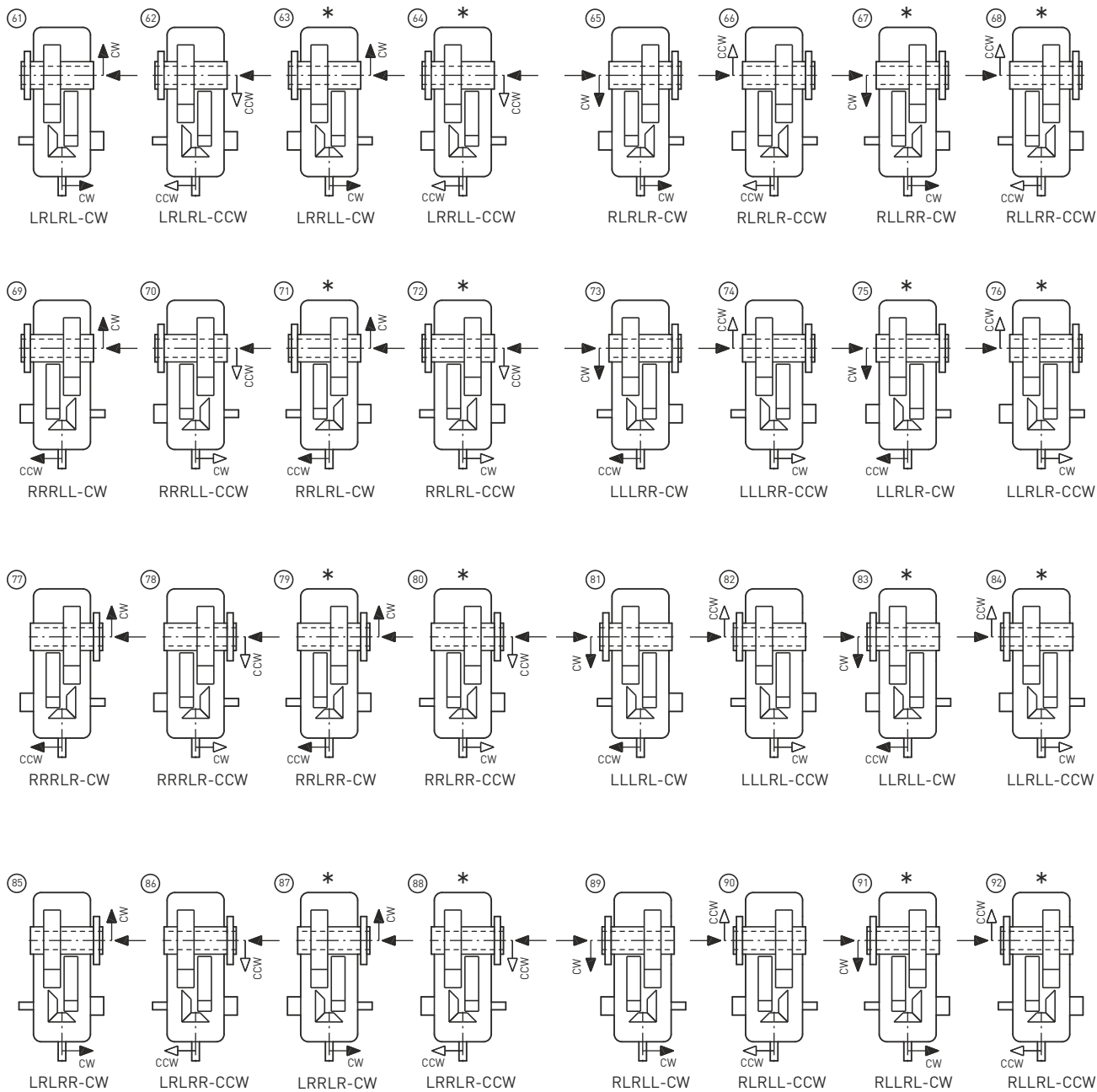

type - K4H

Quadruple Stage
Size 17 to 18

Horizontal Mounting

Bevel Helical Gear Unit

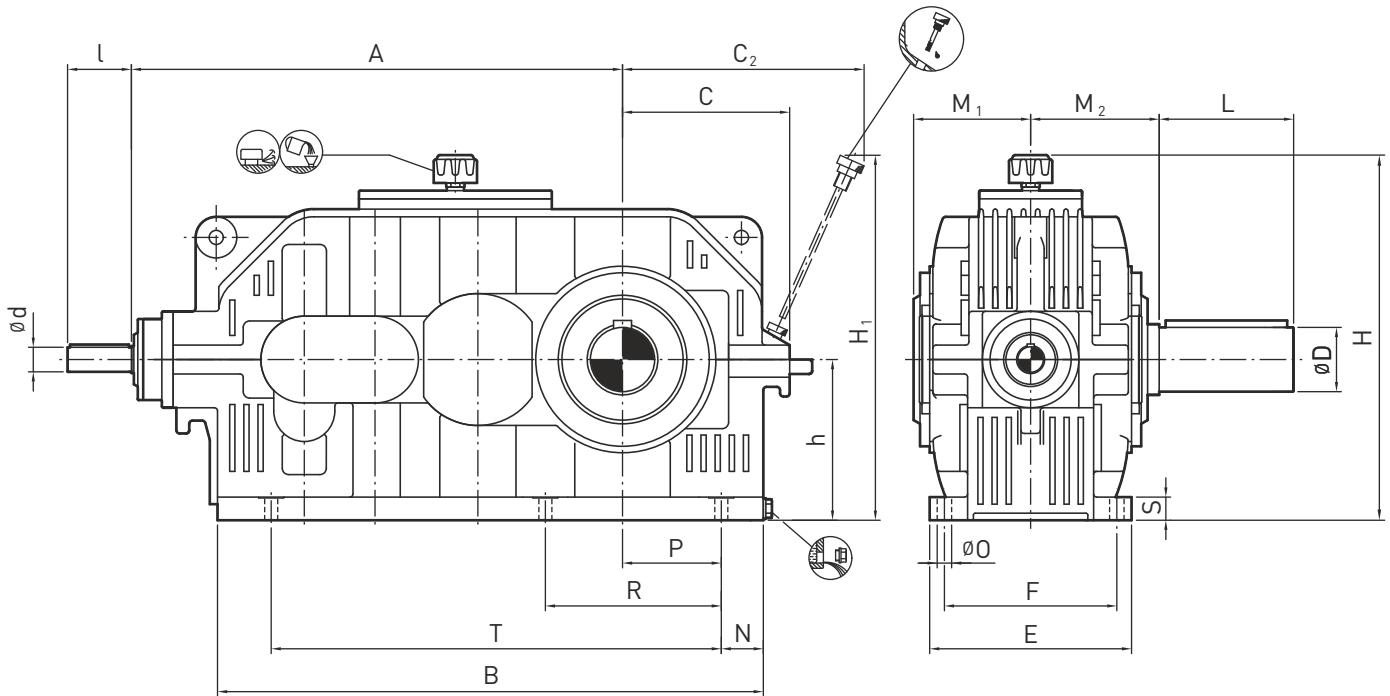

*For other shaft options refer page 60 to 64.

Size	Input Shaft				Output Shaft				Backstop			Average Weight [kg]	Oil Quantity [Litres]
	i = 80-225		i = 250-400		D	L	M ₁	M ₂	A ₁	d ₁ ¹⁾	Y ¹⁾		
	d	l	d	l									
K4..17	19	90	19	90	70	135	141	150	350	85	210	175	9
K4..18	24	100	24	100	80	160	158	170	395	95	255	235	13

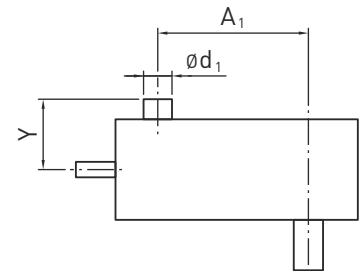

Size	Foundation														
	A	B	C	C ₂ ¹⁾	E	F	h	H ₁ ¹⁾	H ₂ ²⁾	N	O	P	R	S	T
K4..17	545	592	190	257	250	210	180	378	450	43	18	115	210	32	495
K4..18	600	671	215	281	284	230	200	404	490	43	18	135	240	32	565

Modification of dimensions reserved.

Shaft ends with keys according to DIN 6885, part 1, Shape A.

Shaft centering according to DIN 332, shape DS (with thread)

Tolerance field for shaft ends ISO fit, up to Ø50 k6; over Ø50 m6.

1) Max. dimensions; details acc. to order related documents

2) Approximate values; exact values acc. to order related documents

Bevel Helical Gear Unit

Horizontal Mounting

Type - **K4H**
Quadruple Stage
Size 19 to 26

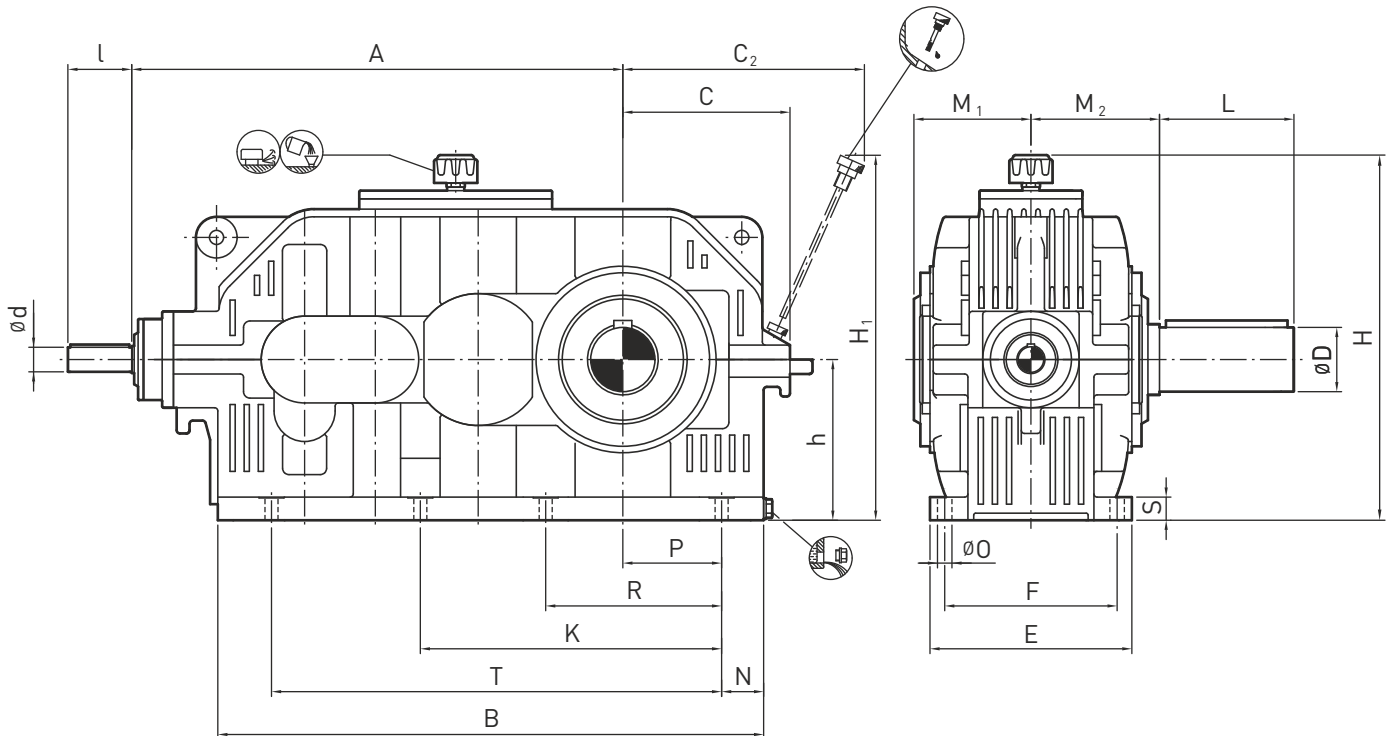

*For other shaft options refer page 60 to 64.

Size	Input Shaft				Output Shaft				Backstop		Average Weight [kg]	Oil Quantity [Litres]	
	d	l	d	l	D	L	M ₁	M ₂	A ₁	d ₁ ¹⁾			Y ¹⁾
K4..19	24	100	24	100	90	165	171	180	440	95	255	320	18
K4..20	28	100	24	100	100	200	176	200	495	95	255	430	26
K4..21	32	110	28	100	110	200	210	220	555	135	310	580	33
K4..22	38	110	32	110	120	210	220	230	620	135	310	780	46
K4..23	42	130	38	110	140	250	234	260	700	140	310	1060	65
K4..24	48	130	42	130	160	290	283	295	785	175	415	1430	90
K4..25	52	130	48	130	170	300	293	305	880	175	415	1930	125
K4..26	58	135	52	130	190	350	306	345	990	190	415	2590	180

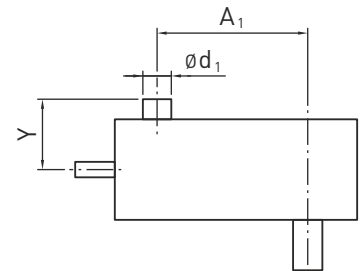

Size	Foundation															
	A	B	C	C ₂ ¹⁾	E	F	h	H ₁ ¹⁾	H ₂ ²⁾	K	N	O	P	R	S	T
K4..19	680	751	240	315	303	250	225	455	540		53	23	145	255	36	615
K4..20	755	849	260	345	314	270	250	496	590		54	23	165	290	36	705
K4..21	845	946	290	394	385	310	280	572	650		64	27	180	315	45	780
K4..22	940	1060	325	429	400	340	315	635	720		75	27	200	355	45	880
K4..23	1060	1181	355	481	450	380	355	705	800	655	87	33	220	405	55	985
K4..24	1190	1324	390	541	515	410	400	795	890	740	92	33	245	450	55	1110
K4..25	1320	1496	440	591	535	460	450	865	990	840	98	33	280	510	55	1245
K4..26	1485	1686	490	659	600	510	500	954	1090	940	108	39	315	575	65	1400

Modification of dimensions reserved.

Shaft ends with keys according to DIN 6885, part 1, Shape A.

Shaft centering according to DIN 332, shape DS (with thread)

Tolerance field for shaft ends ISO fit, up to Ø50 k6; over Ø50 m6.

1) Max. dimensions; details acc. to order related documents

2) Approximate values; exact values acc. to order related documents

type - K4T

Quadruple Stage
Size 17 to 18

Torque Arm Mounting

Bevel Helical Gear Unit

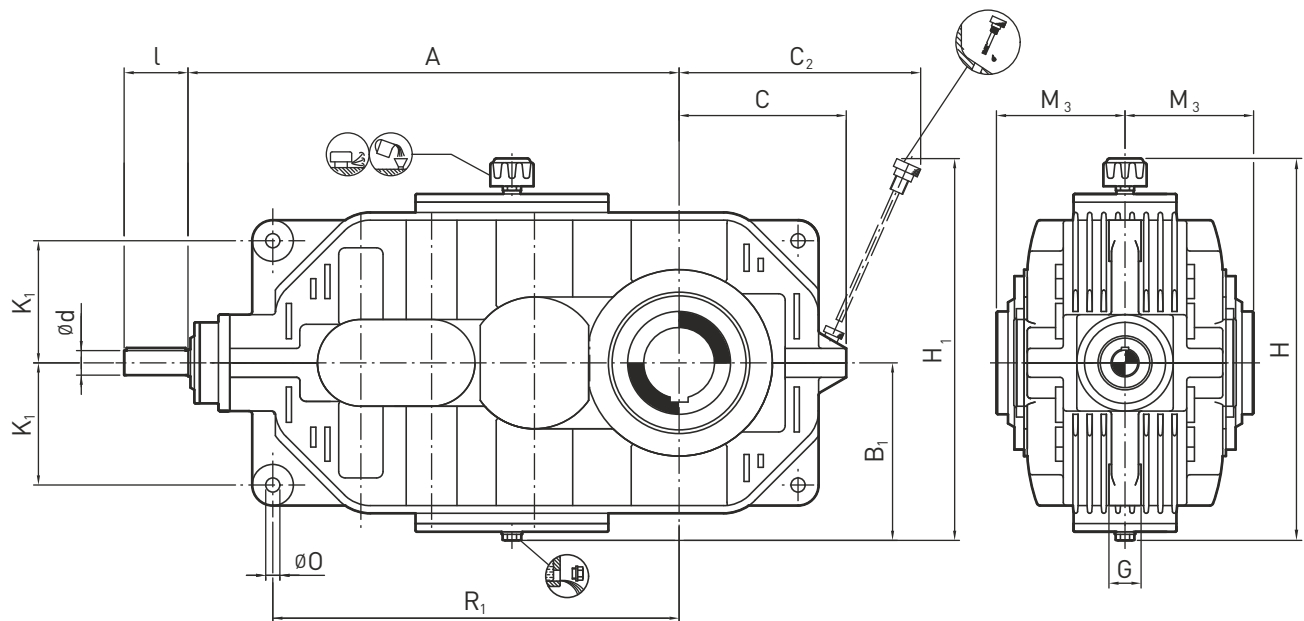

Size	Input Shaft				Output Shaft M ₃	Backstop			Average Weight [kg]	Oil Quantity [Litres]
	i = 80-225		i = 250-400			A ₁	d ₁ ¹⁾	Y ¹⁾		
	d	l	d	l						
K4..17	19	90	19	90	150	350	85	210	150	6
K4..18	24	100	24	100	170	395	95	255	205	8

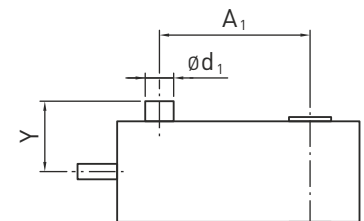

Size	Foundation									
	A	B ₁ ²⁾	C	C ₂ ¹⁾	G	H ²⁾	H ₁ ¹⁾	K ₁	O	R ₁
K4..17	545	210	190	257	32	480	408	136	20	442
K4..18	600	230	215	281	35	520	434	145	24	500

Modification of dimensions reserved.

Shaft ends with keys according to DIN 6885, part 1, Shape A.

Shaft centering according to DIN 332, shape DS (with thread)

Tolerance field for shaft ends ISO fit, up to Ø50 k6; over Ø50 m6.

1) Max. dimensions; details acc. to order related documents

2) Approximate values; exact values acc. to order related documents

Bevel Helical Gear Unit

Torque Arm Mounting

Type - K4T
Quadruple Stage
Size 19 to 26

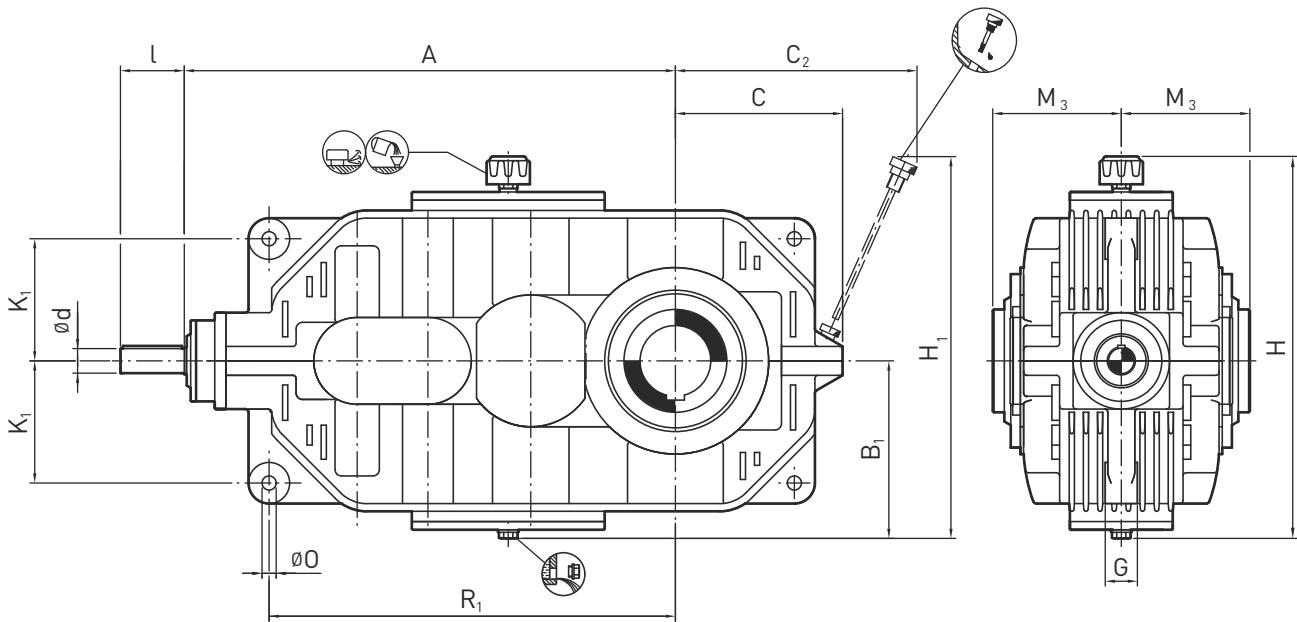

Size	Input Shaft				Output Shaft	Backstop			Average Weight [kg]	Oil Quantity [Litres]
	d	l	d	l		M ₃	A ₁	d ₁ ¹⁾		
K4..19	24	100	24	100	180	440	95	255	280	12
K4..20	28	100	24	100	190	495	95	255	370	17
K4..21	32	110	28	100	220	555	135	310	500	21
K4..22	38	110	32	110	230	620	135	310	670	28
K4..23	42	130	38	110	260	700	140	310	910	40
K4..24	48	130	42	130	295	785	175	415	1170	55
K4..25	52	130	48	130	305	880	175	415	1580	80
K4..26	58	135	52	130	345	990	190	415	2070	115

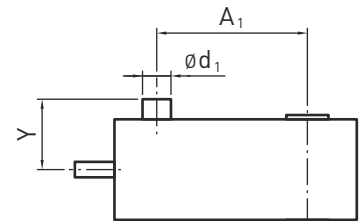

Size	Foundation									
	A	B ₁ ²⁾	C	C ₂ ¹⁾	G	H ²⁾	H ₁ ¹⁾	K ₁	O	R ₁
K4..19	680	255	240	315	45	570	485	170	24	560
K4..20	755	280	260	345	50	620	526	190	28	632
K4..21	845	310	290	394	55	680	602	222	28	710
K4..22	940	345	325	429	60	750	665	255	36	790
K4..23	1060	385	355	481	70	830	735	290	40	882
K4..24	1190	430	390	541	80	920	825	325	48	985
K4..25	1320	480	440	591	90	1020	895	370	48	1115
K4..26	1485	530	490	659	105	1120	984	415	55	1265

Modification of dimensions reserved.

Shaft ends with keys according to DIN 6885, part 1, Shape A.

Shaft centering according to DIN 332, shape DS (with thread)

Tolerance field for shaft ends ISO fit, up to Ø50 k6; over Ø50 m6.

1) Max. dimensions; details acc. to order related documents

2) Approximate values; exact values acc. to order related documents

type - K4
Quadruple Stage

Shaft Arrangement

Bevel Helical Gear Unit

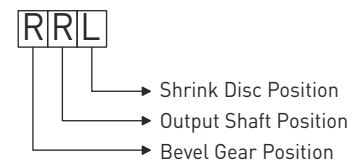
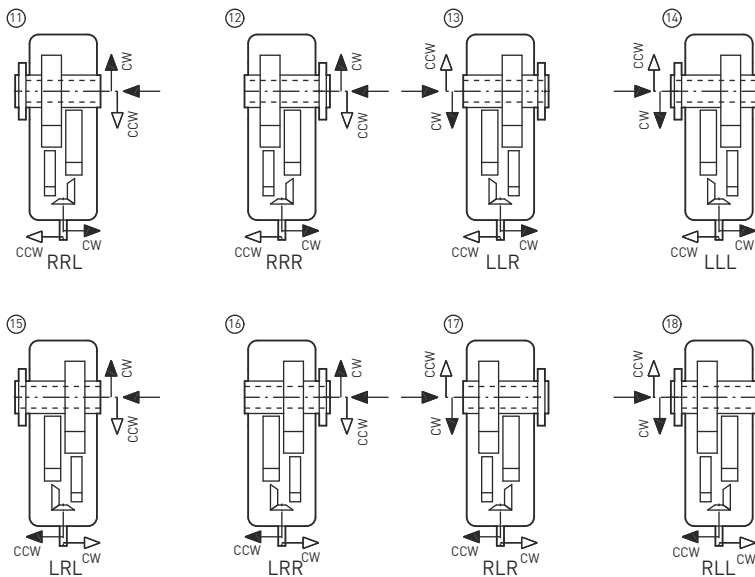
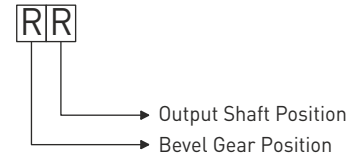
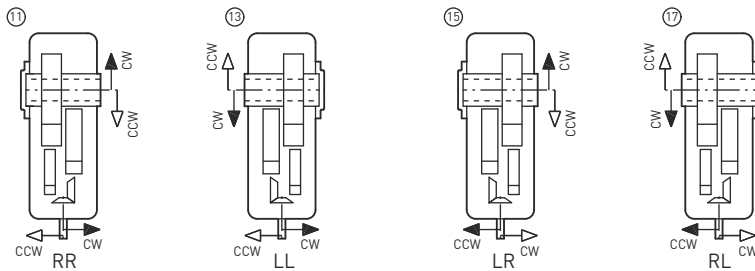
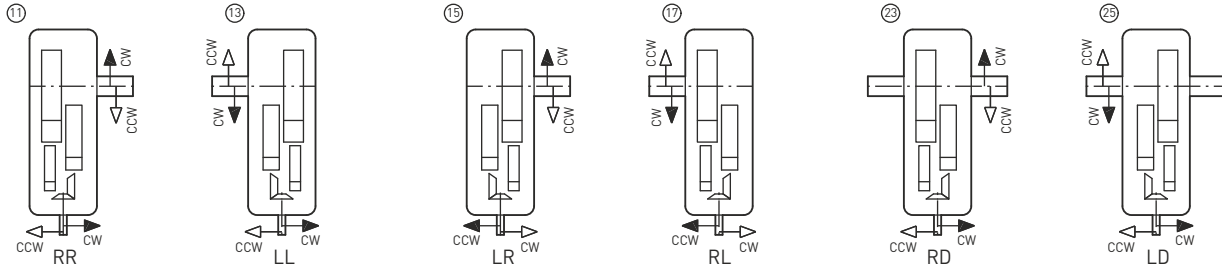

Bevel Helical Gear Unit

Shaft Arrangement - Int. Ext.

Type - K4
 Quadruple Stage

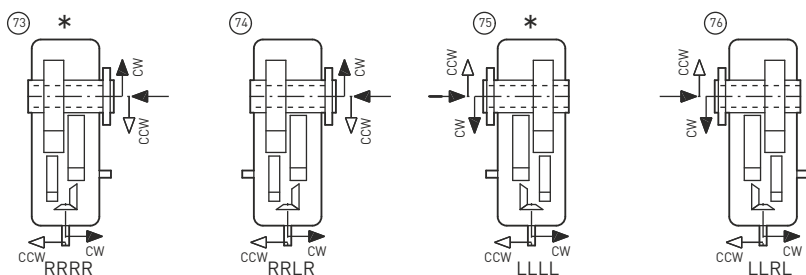
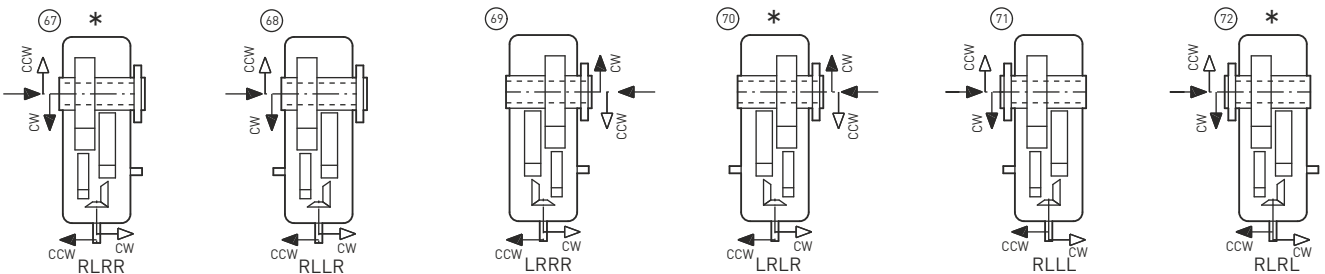
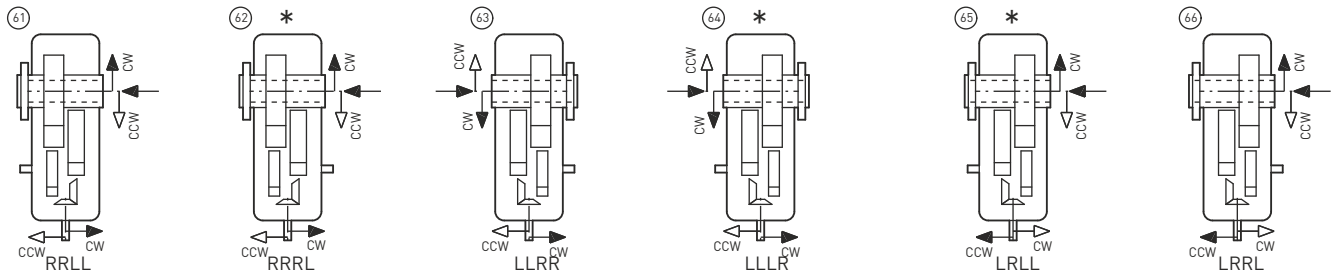
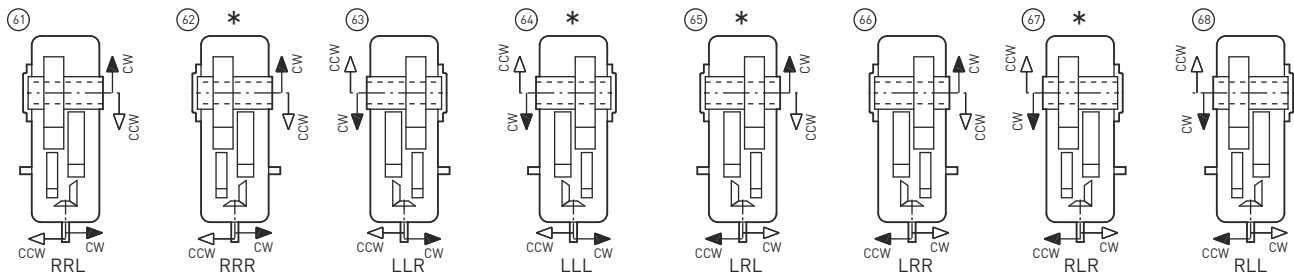
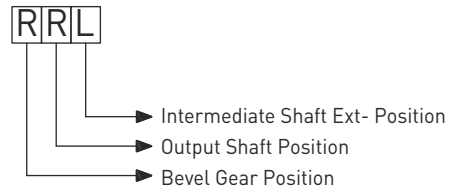
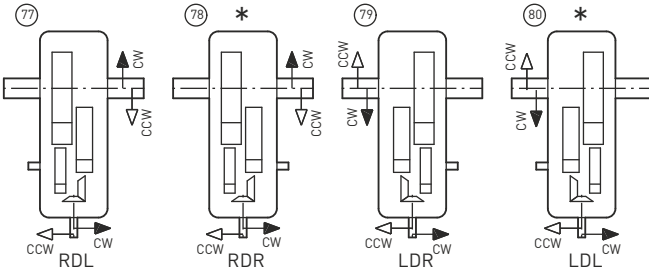
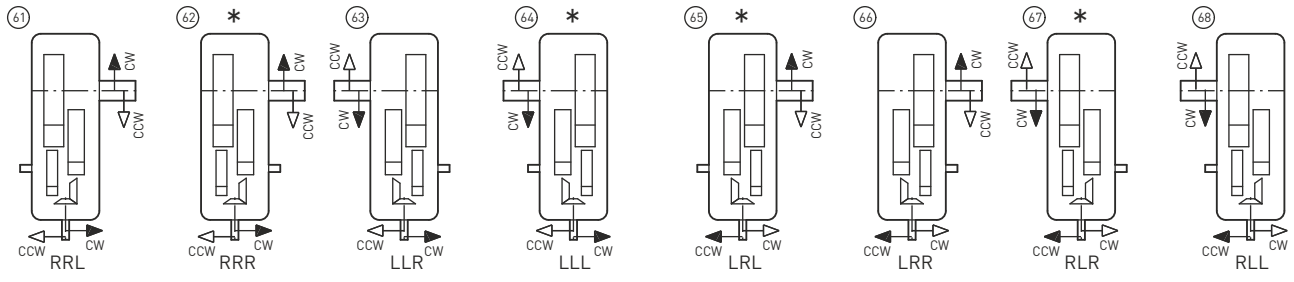

type - K4
Quadruple Stage

Shaft Arrangement - Hold Back

Bevel Helical Gear Unit

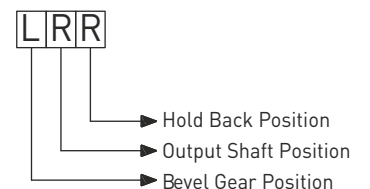
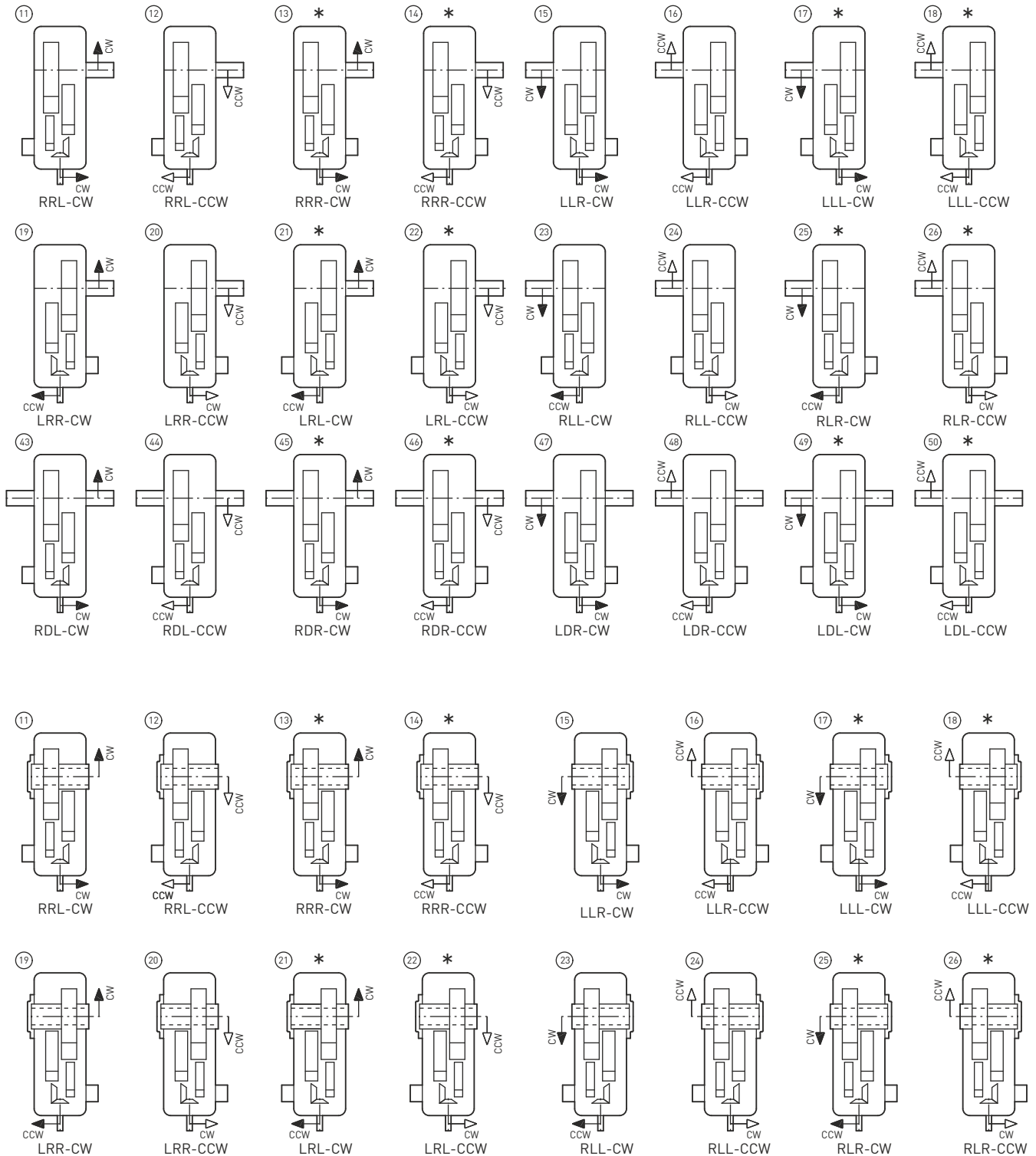

Bevel Helical Gear Unit

Shaft Arrangement - Hold Back

Type - K4
Quadruple Stage

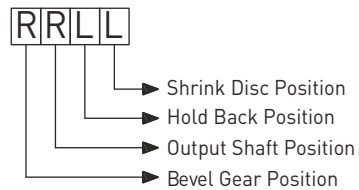
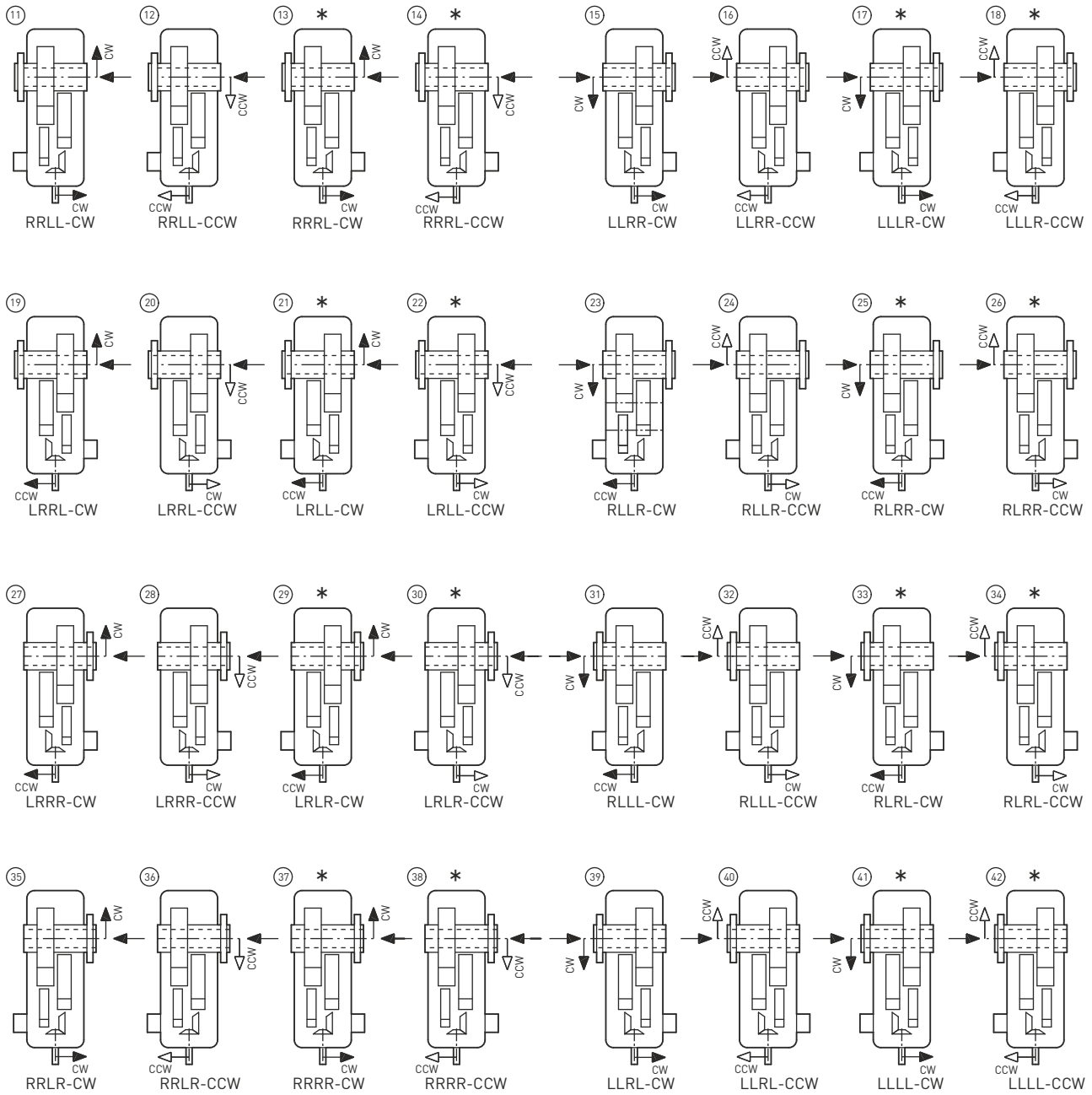

type - R4
Quadruple Stage

Shaft Arrangement - Int.Ext. & Hold Back

Bevel Helical Gear Unit

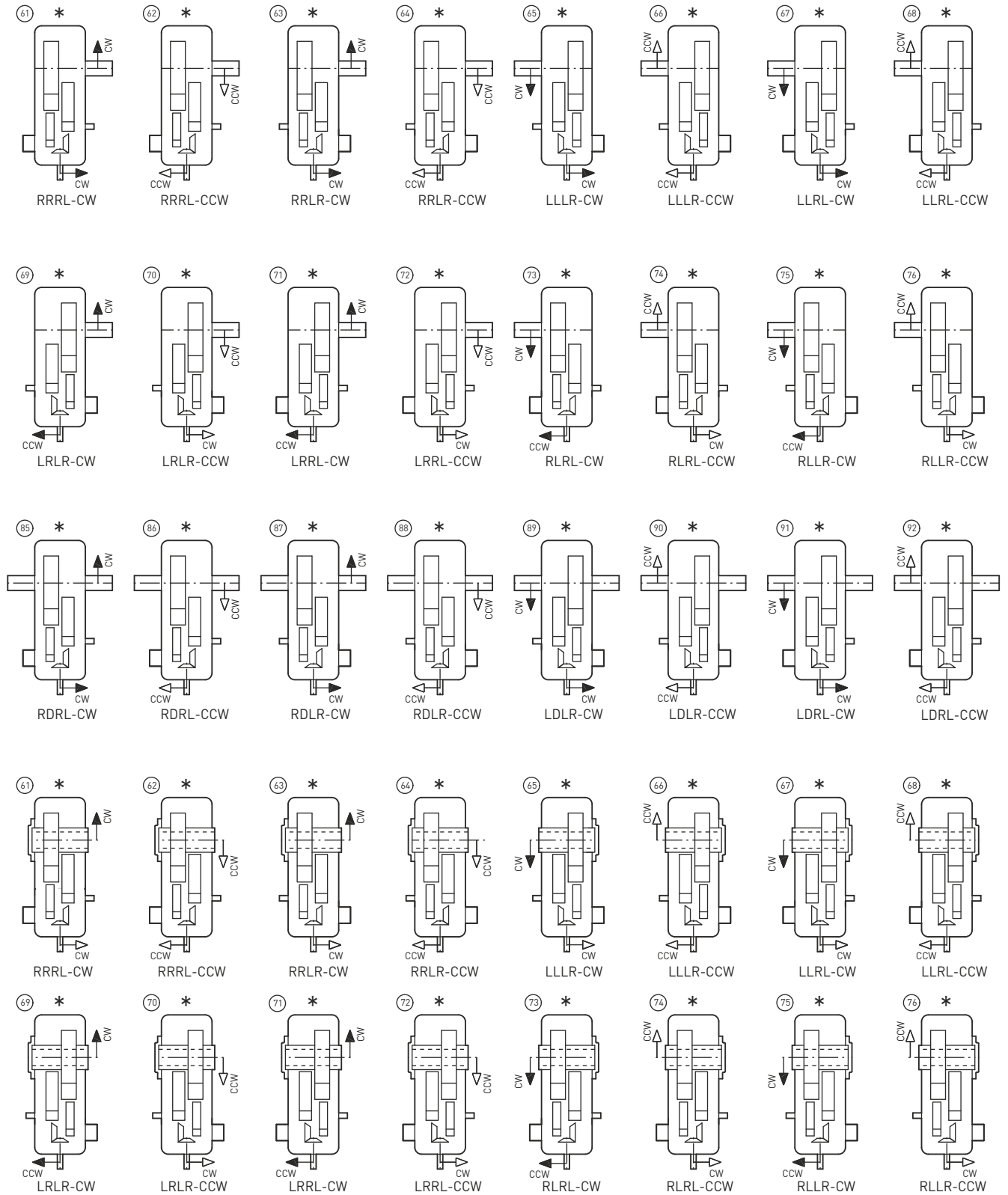

LRLR

- Hold Back Position
- Intermediate Shaft Ext- Position
- Output Shaft Position
- Bevel Gear Position

Bevel Helical Gear Unit Shaft Arrangement - Int.Ext. & Hold Back

Type - K4
Quadruple Stage

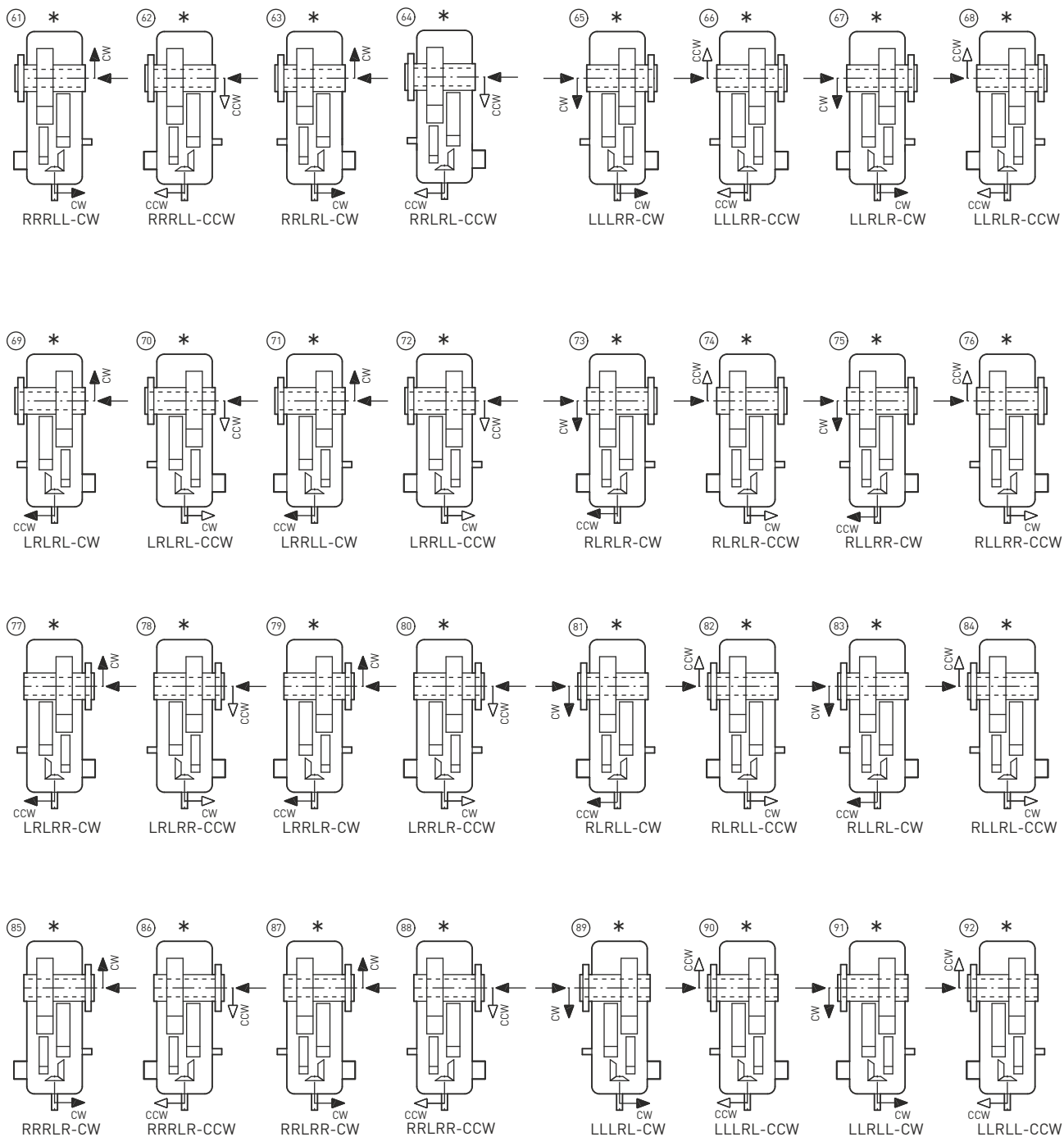

LRLRR

- Shrink Disc Position
- Hold Back Position
- Intermediate Shaft Ext- Position
- Output Shaft Position
- Bevel Gear Position

Output Shaft Types

Helical / Bevel-Helical Gear Units

Size	Solid Output Shaft			
	D	L	M ₁	M ₂
11	32	55	93.5	105
13	45	95	106	115
14	48	95	106	125
15	55	95	127	135
16	60	130	132.5	145
17	70	135	141	150
18	80	160	158	170

Solid Output Shaft - (N)

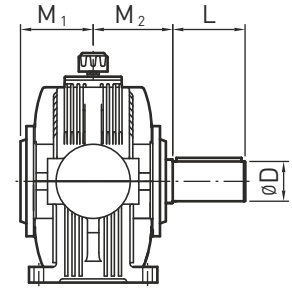

Size	Hollow Shaft Key	
	D ₁	M ₃
11	35	105
13	50	115
14	55	120
15	60	135
16	70	145
17	75	150
18	90	170

Hollow Output Shaft With Keyway - (K)

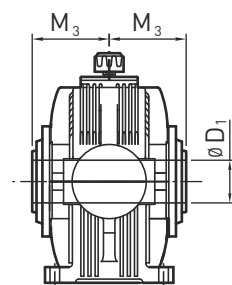

Size	Hollow Shaft (Shrink Disc)		
	D ₂	M ₃	M ₄
14	60	120	200
15	65	135	215
16	75	145	235
17	80	150	250
18	95	170	280

Hollow Output Shaft With Shrink Disc - (D)

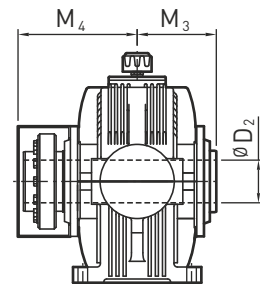

Size	Hollow Shaft (Spline)		
	D ₃	D ₄	M ₃
11	Dimensions on request		
13			
14			
15			
16			
17			
18			

Hollow Output Shaft With Spline - (S)

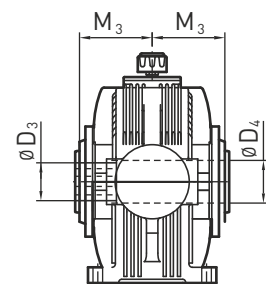

Size	Flanged Shaft							
	D ₅	D ₆	K ₁	K x Ø d ₂	L ₁	L ₂	M ₁	M ₅
11	Dimensions on request							
13								
14								
15								
16								
17								
18								

Flanged Shaft - (F)

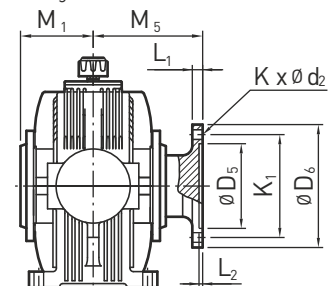

Modification of dimensions reserved.

Shaft ends with keys according to DIN 6885, part 1, Shape A.

Shaft centering according to DIN 332, shape DS (with thread)

Tolerance field for Shaft ends ISO fit, up to Ø50 k6; over Ø50 m6.

Helical / Bevel-Helical Gear Units

Output Shaft Types

Size	Solid Output Shaft			
	D	L	M ₁	M ₂
19	90	165	170.5	180
20	100	200	176	200
21	110	200	210	220
22	120	210	220	230
23	140	250	234	260
24	160	290	282.5	295
25	170	300	292.5	305
26	190	350	305.5	345

Solid Output Shaft - (N)

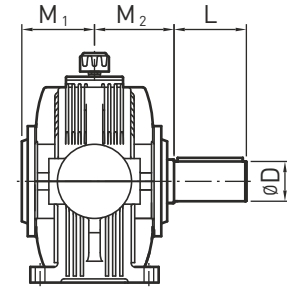

Size	Hollow Shaft Key	
	D ₁	M ₃
19	105	180
20	110	190
21	120	220

Hollow Output Shaft With Keyway - (K)

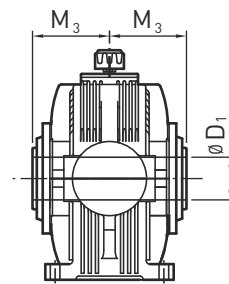

Size	Hollow Shaft (Shrink Disc)		
	D ₂	M ₃	M ₄
19	105	180	300
20	115	190	315
21	125	220	360
22	140	230	395
23	160	260	445
24	180	295	485
25	200	305	515
26	220	345	575

Hollow Output Shaft With Shrink Disc - (D)

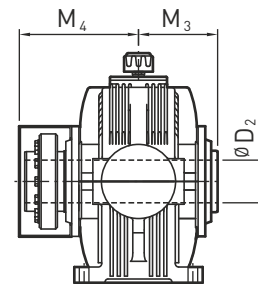

Size	Hollow Shaft (Spline)		
	D ₃	D ₄	M ₃
19	Dimensions on request		
20			
21			
22			
23			
24			
25			
26			

Hollow Output Shaft With Spline - (S)

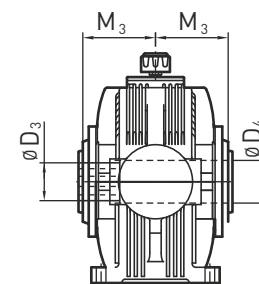

Size	Flanged Shaft							
	D ₅	D ₆	K ₁	K x Ø d ₂	L ₁	L ₂	M ₁	M ₅
19	Dimensions on request							
20								
21								
22								
23								
24								
25								
26								

Flanged Shaft - (F)

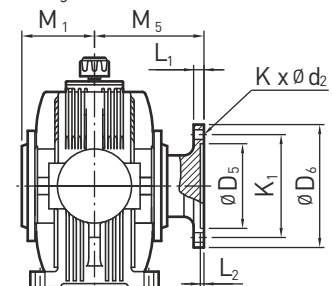

Modification of dimensions reserved.

Shaft ends with keys according to DIN 6885, part 1, Shape A.

Shaft centering according to DIN 332, shape DS (with thread)

Tolerance field for Shaft ends ISO fit, up to Ø50 k6; over Ø50 m6.

Hollow Output Shaft Design with Fitted Key

Helical/Bevel-Helical Gear Units

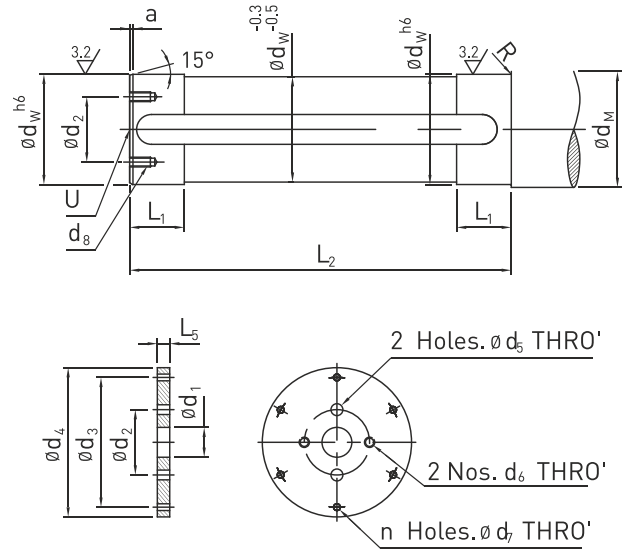
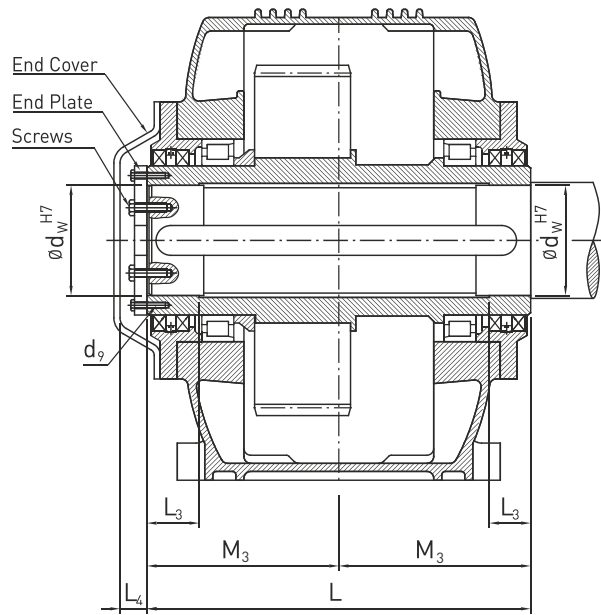

End Plate (Size 13 onwards)

Size	Hollow Shaft						Driven Machine Shaft							End Plate										
	d_w	L	M_3	L_3	L_4	d_9	d_w	d_M	d_2	d_8	L_1	L_2	a	R	U	d_1	d_2	d_3	d_4	d_5	d_6	d_7	n	L_5
11	35	210	105	30	23	M5 x 9	35	55	-	-	35	207	3	2.5	M10	-	-	-	-	-	-	-	-	-
13	50	230	115	45	23	M5 x 9	50	70	35	M8 x 16	50	227	3	2.5	M16	18	35	60	69.5	9	M8	5.5	4	8
14	55	240	120	50	25	M6 x 12	55	75	40	M8 x 16	55	237	4	2.5	M20	22	40	67.5	79	9	M10	6.6	4	8
15	60	270	135	55	25	M6 x 12	60	80	45	M10 x 20	60	267	4	2.5	M20	22	45	72.5	89	11	M10	6.6	6	8
16	70	290	145	65	25	M6 x 12	70	90	50	M10 x 20	70	287	4	2.5	M20	22	50	85	99	11	M10	6.6	6	8
17	75	300	150	70	30	M6 x 12	75	95	55	M10 x 20	75	297	5	4	M20	22	55	90	109	11	M10	6.6	6	10
18	90	340	170	85	30	M8 x 15	90	110	65	M10 x 20	90	337	5	4	M24	26	65	110	129	11	M10	9	4	10
19	105	360	180	100	32	M8 x 15	105	125	70	M12 x 25	105	357	5	4	M24	26	70	120	139	14	M12	9	4	10
20	110	380	190	110	32	M10 x 17	110	135	75	M12 x 25	115	377	5	4	M24	26	75	125	159	14	M12	11	4	12
21	120	440	220	120	32	M10 x 17	120	150	80	M12 x 25	130	437	6	6	M24	26	80	140	169	14	M12	11	4	12

Hollow Shaft Bore Details

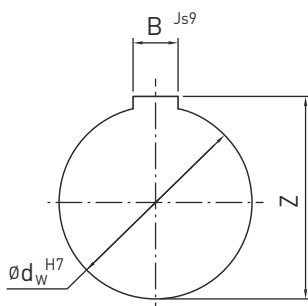

d_w	B	Z	tol. on Z
35	10	38.3	+0.2
50	14	53.8	
55	16	59.3	
60	18	64.4	
70	20	74.9	
75	20	79.9	
90	25	95.4	
105	28	111.4	
110	28	116.4	
120	32	127.4	

d_w	tol. field	tol
35	H7	+0.025
50		0
55	H7	+0.030
60		
70		
75		
90	H7	+0.035
105		
110		
120		

B	tol. field	tol
10	Js9	+0.018 -0.018
12	Js9	+0.022 -0.022
14		
16		
18	Js9	+0.026 -0.026
20		
25	Js9	+0.026 -0.026
28	Js9	+0.031 -0.031
32		

Helical/Bevel-Helical Gear Units

Hollow Output Shaft Design with Shrink Disc

Standard Shaft Mounting Position

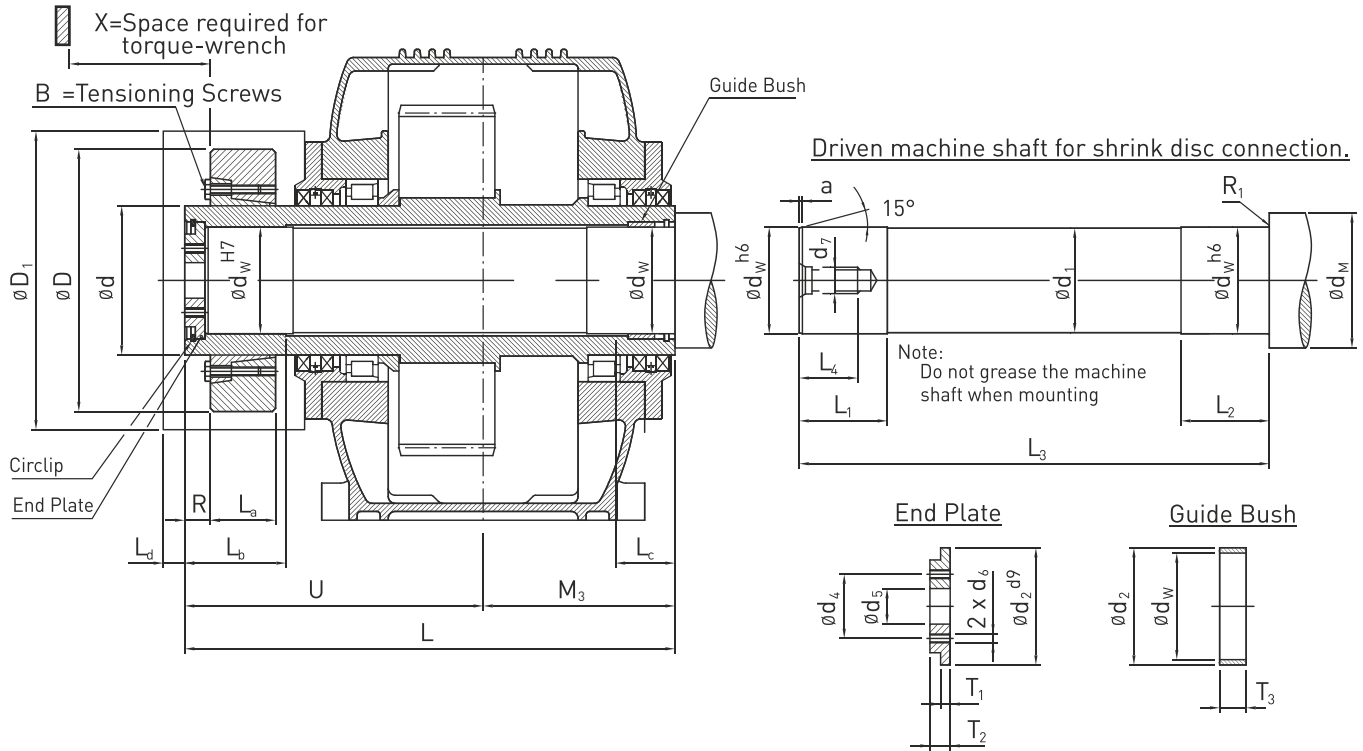

Size	Hollow Shaft								Shrink Disc										Weight (kg)
	d_w	L	L_b	L_c	U	M_3	R	Type	D	d	D_1 (Approx)	L_a	L_d	M_t (da Nm)	B	M_a (da Nm)			
14	60	300	50	30	180	120	17	80 - 60	141	80	175	31	20	319	M10	5.8	2.3		
15	65	330	55	35	195	135	17	90 - 65	155	90	190	38	20	540	M10	5.8	3.2		
16	75	360	65	40	215	145	20	100 - 75	170	100	215	43.5	20	720	M10	5.8	4.3		
17	80	380	80	41	230	150	26	110 - 80	185	110	225	49	20	1000	M12	10	5.8		
18	95	430	85	44	260	170	27	125 - 95	215	125	260	53.5	20	1650	M12	10	8.7		
19	105	460	95	49	280	180	32	140 - 105	230	140	270	58	20	2210	M14	16	10.3		
20	115	485	100	49	295	190	33	155 - 115	263	155	305	63	20	2950	M14	16	15.2		
21	125	555	120	68	335	220	35	165 - 125	290	165	335	68	25	4120	M16	24	21.5		
22	140	600	135	68	370	230	35	180 - 140	320	180	365	85.5	25	6400	M16	24	32.7		
23	160	680	155	73	420	260	37	220 - 160	370	220	415	105	25	10300	M20	47	53		
24	180	755	160	83	460	295	38	240 - 180	405	240	460	109	25	14000	M20	47	66		
25	200	795	180	88	490	305	46	260 - 200	430	260	495	120	25	18400	M20	47	82		
26	220	895	190	103	550	345	48	280 - 220	460	280	530	135	25	24000	M20	47	103		

Size	Driven Machine Shaft										End Plate						Guide Bush			
	d_w	d_1	d_m (min)	R_1	L_1	L_2	L_3	L_4	d_7	a	d_2	d_4	d_5	d_6	T_1	T_2	d_w	d_2	T_3	Circlip
14	60	59.5	80	1.5	45	65	286	42	M20	4	65	35	22	M6	5	13	60	65	17	65 x 2.5
15	65	64.5	85	1.5	50	70	316	42	M20	4	70	40	22	M8	5	13	65	70	22	70 x 2.5
16	75	74.5	95	1.5	55	75	342	42	M20	4	80	45	22	M8	7	17	75	80	23	80 x 2.5
17	80	79.5	100	1.6	70	90	362	42	M20	5	85	50	22	M8	7	17	80	85	24	85 x 3
18	95	94.5	120	1.6	70	90	408	50	M24	5	100	55	26	M10	8	20	95	100	24	100 x 3
19	105	104.5	130	1.6	80	100	438	50	M24	5	110	60	26	M10	8	20	105	110	29	110 x 4
20	115	114.5	140	1.6	85	105	463	50	M24	5	120	65	26	M10	8	20	115	120	29	120 x 4
21	125	124.5	160	2.5	85	110	530	50	M24	6	130	65	26	M12	10	23	125	130	45	130 x 4
22	140	139.5	170	2.5	105	130	575	60	M30	6	145	75	33	M12	10	23	140	145	45	145 x 4
23	160	159.5	190	2.5	130	155	655	60	M30	6	165	80	33	M12	10	23	160	165	50	165 x 4
24	180	179.5	210	2.5	130	160	725	60	M30	6	185	85	33	M16	12	28	180	185	55	185 x 4
25	200	199.5	240	4	150	180	765	60	M30	8	205	95	33	M16	12	28	200	205	60	210 x 5
26	220	219.5	260	4	165	195	865	80	M36	8	225	110	39	M20	12	28	220	225	75	225 x 5

M_a = Required tightening torque.

M_t = Maximum torque transmitted by shrink disc.

Helical/Bevel-Helical Gear Units

Hollow Output Shaft Design with Shrink Disc

Alternate Shaft Mounting Option

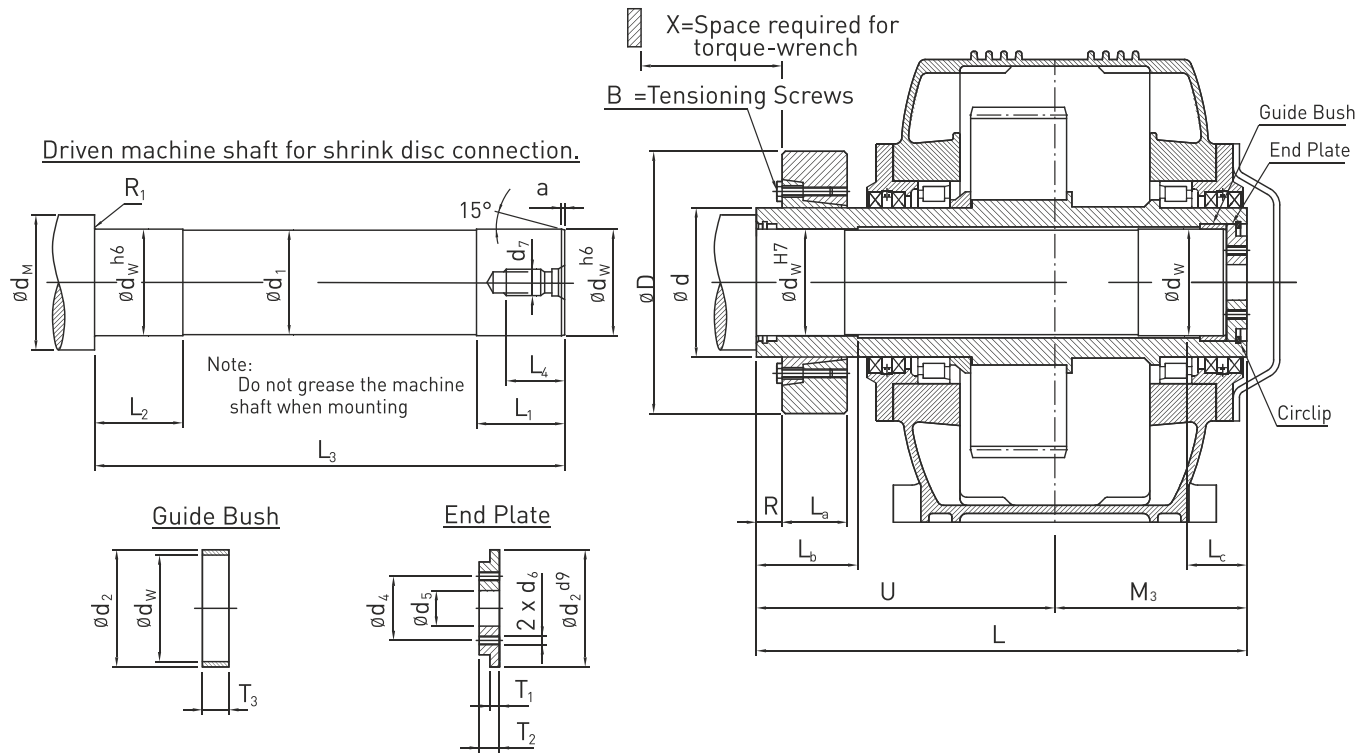

Size	Hollow Shaft							Type	Shrink Disc									
	d_w	L	L_b	L_c	U	M_3	R		D	d	L_a	L_d	M_t (da Nm)	B	M_a (da Nm)	Weight (kg)		
14	60	300	50	30	180	120	17	80 - 60	141	80	31	25	319	M10	5.8	2.3		
15	65	330	55	35	195	135	17	90 - 65	155	90	38	25	540	M10	5.8	3.2		
16	75	360	65	40	215	145	20	100 - 75	170	100	43.5	25	720	M10	5.8	4.3		
17	80	380	80	41	230	150	26	110 - 80	185	110	49	30	1000	M12	10	5.8		
18	95	430	85	44	260	170	27	125 - 95	215	125	53.5	30	1650	M12	10	8.7		
19	105	460	95	49	280	180	32	140 - 105	230	140	58	32	2210	M14	16	10.3		
20	115	485	100	49	295	190	33	155 - 115	263	155	63	32	2950	M14	16	15.2		
21	125	555	120	68	335	220	35	165 - 125	290	165	68	32	4120	M16	24	21.5		
22	140	600	135	68	370	230	35	180 - 140	320	180	85.5	40	6400	M16	24	32.7		
23	160	680	155	73	420	260	37	220 - 160	370	220	105	40	10300	M20	47	53		
24	180	755	160	83	460	295	38	240 - 180	405	240	109	40	14000	M20	47	66		
25	200	795	180	88	490	305	46	260 - 200	430	260	120	40	18400	M20	47	82		
26	220	895	190	103	550	345	48	280 - 220	460	280	135	40	24000	M20	47	103		

Size	Driven Machine Shaft										End Plate						Guide Bush			
	d_w	d_1	d_m (min)	R_1	L_1	L_2	L_3	L_4	d_7	a	d_2	d_4	d_5	d_6	T_1	T_2	d_w	d_2	T_3	Circlip
14	60	59.5	80	1.5	45	65	286	42	M20	4	65	35	22	M6	5	13	60	65	17	65 x 2.5
15	65	64.5	85	1.5	50	70	316	42	M20	4	70	40	22	M8	5	13	65	70	22	70 x 2.5
16	75	74.5	95	1.5	55	75	342	42	M20	4	80	45	22	M8	7	17	75	80	23	80 x 2.5
17	80	79.5	100	1.6	70	90	362	42	M20	5	85	50	22	M8	7	17	80	85	24	85 x 3
18	95	94.5	120	1.6	70	90	408	50	M24	5	100	55	26	M10	8	20	95	100	24	100 x 3
19	105	104.5	130	1.6	80	100	438	50	M24	5	110	60	26	M10	8	20	105	110	29	110 x 4
20	115	114.5	140	1.6	85	105	463	50	M24	5	120	65	26	M10	8	20	115	120	29	120 x 4
21	125	124.5	160	2.5	85	110	530	50	M24	6	130	65	26	M12	10	23	125	130	45	130 x 4
22	140	139.5	170	2.5	105	130	575	60	M30	6	145	75	33	M12	10	23	140	145	45	145 x 4
23	160	159.5	190	2.5	130	155	655	60	M30	6	165	80	33	M12	10	23	160	165	50	165 x 4
24	180	179.5	210	2.5	130	160	725	60	M30	6	185	85	33	M16	12	28	180	185	55	185 x 4
25	200	199.5	240	4	150	180	765	60	M30	8	205	95	33	M16	12	28	200	205	60	210 x 5
26	220	219.5	260	4	165	195	865	80	M36	8	225	110	39	M20	12	28	220	225	75	225 x 5

M_a = Required tightening torque.

M_t = Maximum torque transmitted by shrink disc.

www.famcocorp.com

E-mail: info@famcocorp.com

@famco_group

Tel: ۰۲۱-۴۸۰۰۰۰۴۹

Fax: ۰۲۱-۴۴۹۹۴۶۴۲

تهران، کیلومتر ۲۱ بزرگراه لشگری (جاده مخصوص کرج)

روبروی پالایشگاه نفت پارس، پلاک ۱۲

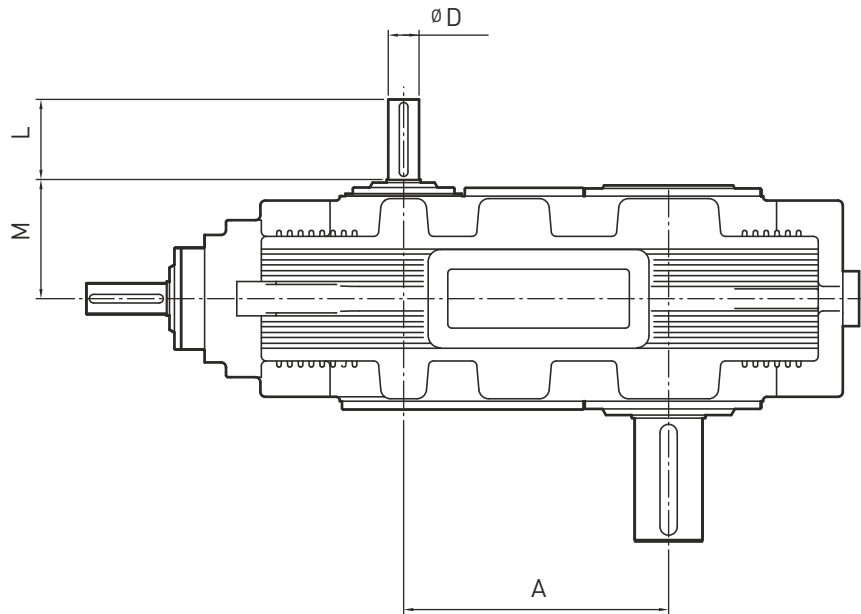

K2 / K3 / K4

K2				
Size	A	D	L	M
11	80	19	30	105
13	100	24	40	115
15	125	38	60	145
17	160	38	60	145
18	180	52	80	185
20	225	52	80	185
21	250	70	105	250
22	280	70	105	250
23	315	70	105	250
24	355	105	170	325
25	400	105	170	325
26	450	105	170	325

K3/K4				
Size	A	D	L	M
14	190	19	30	125
15	215	24	50	145
16	240	24	50	145
17	270	24	50	145
18	305	35	60	185
19	340	35	60	185
20	385	35	60	185
21	430	58	85	250
22	480	58	85	250
23	540	58	85	250
24	605	*90	*130	325
25	680	*90	*130	325
26	765	*90	*130	325

* Extn at pinion side (refer shaft arrangement)

will be $\varnothing 65 \times 105 L$ for the following ratios.

K3-24 ----- i 22.4 ,31.5,45,63

K3-25 ----- i 28,40,56,80

K3-26 ----- i 35.5,50,71,100.

Modification of dimensions reserved.

Shaft ends with keys according to DIN 6885, part 1, Shape A.

Shaft centering according to DIN 332, shape DS (with thread)

Tolerance field for shaft ends ISO fit, up to $\varnothing 50$ k6; over $\varnothing 50$ m6.

Helical/Bevel-Helical Gear Units

Torque Arm Mounting (Shaft Mounting)

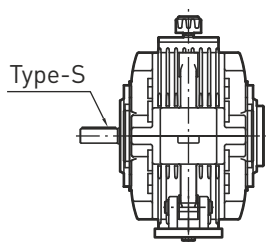
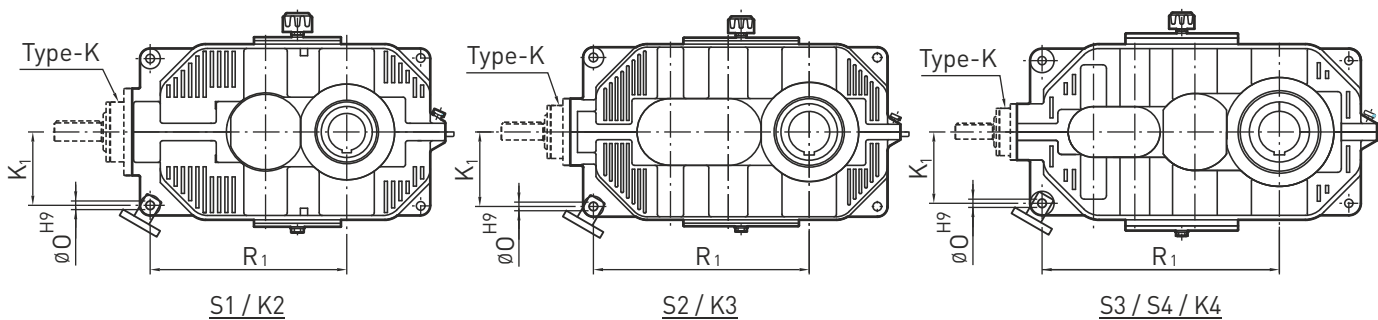

Torque Arm on Driven Machine Side

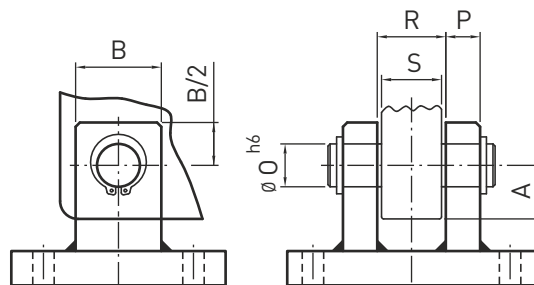

Torque Reaction Arm Details
(Torque Arm not supplied by Elecon)

S1 / K2

Size	R ₁	K ₁	O
11	192	66	10
13	255	90	15
15	316	120	18
17	396	146	20
18	445	156	24
20	550	192	28
21	610	220	28
22	670	255	36
23	745	290	40
24	810	325	48
25	925	370	48
26	1040	416	55

S2 / K3

Size	R ₁	K ₁	O
14	300	90	18
15	336	102	18
16	380	115	20
17	430	136	20
18	478	146	24
19	525	170	24
20	590	190	28
21	660	220	28
22	740	255	36
23	840	290	40
24	930	325	48
25	1035	370	48
26	1165	415	55

S3 / S4 / K4

Size	R ₁	K ₁	O
16	392	116	20
17	442	136	20
18	500	145	24
19	560	170	24
20	632	190	28
21	710	222	28
22	790	255	36
23	882	290	40
24	985	325	48
25	1115	370	48
26	1265	415	55

Size	O	A	B	P	R	S
11	10	20	20	10	23	20
13	15	20	26	12	28	25
14	18	25	30	12	28	25
15	18	25	30	12	32	28
16	20	25	32	16	34	30
17	20	25	32	16	36	32
18	24	25	40	20	40	35
19	24	25	40	20	50	45
20	28	30	45	25	55	50
21	28	30	45	25	60	55
22	36	35	60	32	65	60
23	40	40	65	36	75	70
24	48	50	80	40	85	80
25	48	50	80	40	95	90
26	55	55	90	45	110	105

Modification of dimensions reserved.

Solid Shaft Extension Details

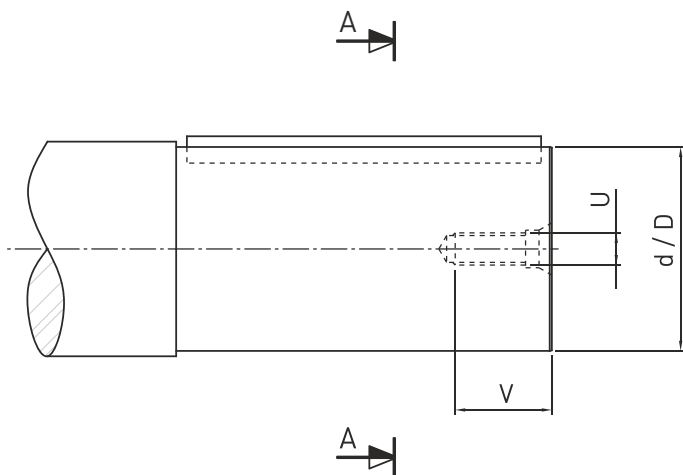

Helical / Bevel-Helical Gear Units

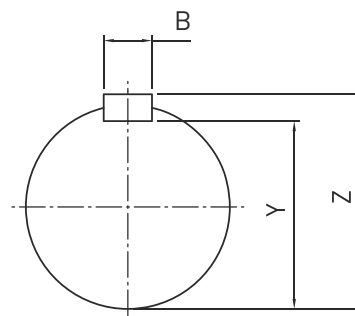

SEC-AA

d / D	B	Y	Z	tol. on Z	U	V
19	6	15.5	21.5	-0.1	M6	16
20	6	16.5	22.5		M6	16
24	8	20	27		M8	19
25	8	21	28		M10	22
28	8	24	31		M10	22
30	8	26	33		M10	22
32	10	27	35		M12	28
35	10	30	38		M12	28
38	10	33	41		M12	28
40	12	35	43		M16	36
42	12	37	45	M16	36	
45	14	39.5	48.5	M16	36	
48	14	42.5	51.5	M16	36	
50	14	44.5	53.5	M16	36	
52	16	46	56	-0.2	M20	42
55	16	49	59		M20	42
58	16	52	62		M20	42
60	18	53	64		M20	42
65	18	58	69		M20	42
70	20	62.5	74.5		M20	42
75	20	67.5	79.5		M20	42
80	22	71	85		M20	42
85	22	76	90		M20	42
90	25	81	95		M24	50
95	25	86	100	M24	50	
100	28	90	106	M24	50	
105	28	95	111	M24	50	
110	28	100	116	M24	50	
115	32	104	122	M24	50	
120	32	109	127	M24	50	
130	32	119	137	M24	50	
140	36	128	148	-0.3	M30	60
145	36	133	153		M30	60
160	40	147	169		M30	60
170	40	157	179		M36	80
190	45	175	200		M36	80

d / D	tol. field	tol
19-30	k6	+0.015 +0.002
32-50	k6	+0.018 +0.002
52-80	m6	+0.030 +0.011
85-120	m6	+0.035 +0.013
140-180	m6	+0.040 +0.015
190-250	m6	+0.046 +0.017

B	tol. field	tol
3 - 6	h9	0 -0.030
8 - 10		0 -0.036
12 - 18		0 -0.043
20 - 28		0 -0.052
32 - 50		0 -0.062

Helical / Bevel-Helical Gear Units

Cooling Coil

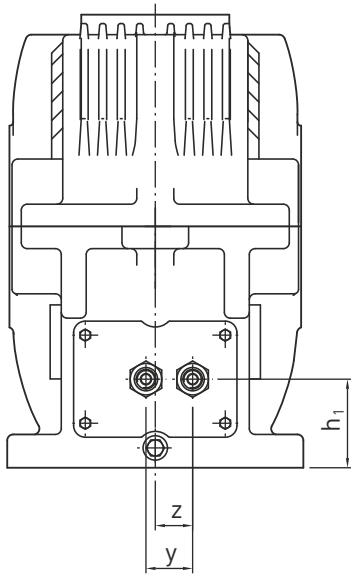

Size 17

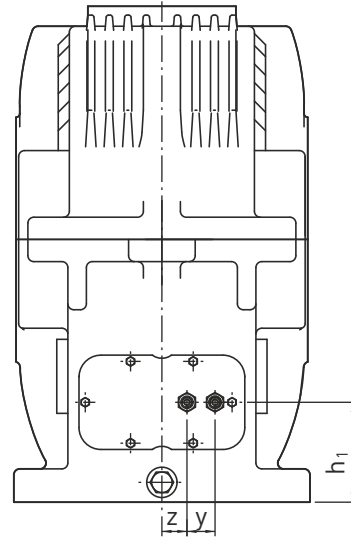

Size 18 and above

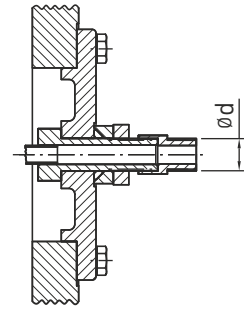

Cooling Coil Connections

Size	S1			
	d	h ₁ ²⁾	y	z
11	Dimensions on request			
13				
15				
17				
18				
20				
21				
22				
23				
24				
25				
26				

Size	S2,S3,S4,K2,K3 & K4			
	d	h ₁ ²⁾	y	z
11	Dimensions on request			
13				
14				
15				
16				
17				
18				
19				
20				
21				
22				
23				
24				
25				
26				

Built-in cooling coils of normal design suitable for fresh water.
[mains and recirculated water not to be chemically polluted]
Sea water and brackish water require cooling coils of special design.
Maximum permissible pressure of water: 8 bar.
The direction of flow of the water is optional.
Contact thermometers and water control valves can also be offered.

2) Approximate values; exact values acc. to order related documents

square values (kg-m²) - S1, S2, S3, S4

Type	i _N	Gear unit Size																
		11	13	14	15	16	17	18	19	20	21	22	23	24	25	26		
S1	1.25	0.0110	0.0381	-	0.1171	-	0.3736	0.6788	-	1.9447	3.1712	5.4903	-	-	-	-		
	1.4	0.0096	0.0331	-	0.1034	-	0.3256	0.5967	-	1.7091	2.8137	4.8453	-	-	-	-		
	1.6	0.0084	0.0288	-	0.0914	-	0.2838	0.5246	-	1.5021	2.4966	4.2761	7.5047	13.7072	24.5190	-		
	1.8	0.0074	0.0251	-	0.0807	-	0.2474	0.4611	-	1.3202	2.2152	3.7737	6.4097	12.0608	21.4817	38.8289		
	2	0.0066	0.0225	-	0.0728	-	0.2229	0.4115	-	1.1754	1.9670	3.3594	5.9417	10.7405	19.2453	34.7051		
	2.24	0.0057	0.0201	-	0.0642	-	0.1974	0.3624	-	1.0437	1.7430	2.9678	5.2070	9.4628	17.1708	30.7868		
	2.5	0.0053	0.0176	-	0.0578	-	0.1775	0.3236	-	0.9308	1.5483	2.6808	4.6199	8.3181	15.0927	27.4575		
	2.8	0.0047	0.0155	-	0.0507	-	0.1563	0.2618	-	0.8321	1.3719	2.3846	4.1078	7.3197	13.4406	23.9837		
	3.15	0.0042	0.0138	-	0.0455	-	0.1389	0.2513	-	0.7322	1.2101	2.0733	3.6029	6.4733	11.7963	21.1103		
	3.55	0.0033	0.0111	-	0.0344	-	0.1085	0.1937	-	0.5787	0.9804	1.6860	2.9046	5.4212	9.7838	17.7320		
	4	0.0029	0.0098	-	0.0296	-	0.0947	0.1688	-	0.4977	0.8441	1.4502	2.5070	4.7576	8.5308	15.4682		
	4.5	0.0026	0.0084	-	0.0257	-	0.0807	0.1451	-	0.4344	0.7397	1.2788	2.1729	4.0887	7.4270	13.3917		
5	0.0023	0.0074	-	0.0224	-	0.0708	0.1269	-	0.3794	0.6393	1.0965	1.8998	3.5340	6.3119	11.3897			
S2	5.6	-	-	0.0158	0.0295	0.0530	0.0970	0.1754	0.2827	0.5422	0.9295	1.5542	3.0090	5.1498	9.2019	16.2044		
	6.3	-	-	0.0135	0.0254	0.0449	0.0824	0.1491	0.2450	0.4536	0.8105	1.3527	2.5445	4.3722	7.6863	13.5713		
	7.1	-	-	0.0116	0.0218	0.0380	0.0699	0.1268	0.2123	0.3795	0.7067	1.1774	2.1516	3.7121	6.4203	11.3660		
	8	-	-	0.0099	0.0188	0.0330	0.0611	0.1113	0.1842	0.3272	0.9962	0.9962	1.8209	3.1782	5.5056	9.7374		
	9	-	-	0.0078	0.0150	0.0261	0.0489	0.0887	0.1475	0.2624	0.4778	0.7890	1.4477	2.4744	4.3944	7.5695		
	10	-	-	0.0074	0.0143	0.0249	0.0468	0.0848	0.1409	0.2501	0.4563	0.7520	1.3820	2.3663	4.1903	7.1912		
	11.2	-	-	0.0059	0.0114	0.0198	0.0375	0.0675	0.1122	0.2016	0.3705	0.5906	1.0835	1.8389	3.2372	5.6135		
	12.5	-	-	0.0057	0.0110	0.0191	0.0363	0.0651	0.1082	0.1938	0.3570	0.5672	1.0421	1.7708	3.1086	5.3753		
	14	-	-	0.0045	0.0086	0.0155	0.0261	0.0482	0.0809	0.1461	0.2621	0.4412	0.8091	1.4061	2.4413	4.2239		
	16	-	-	0.0039	0.0074	0.0134	0.0225	0.0416	0.0710	0.1280	0.2276	0.3791	0.6932	1.2030	2.0904	3.5957		
	18	-	-	0.0030	0.0056	0.0102	0.0170	0.0315	0.0533	0.0968	0.1761	0.2916	0.5363	0.9437	1.6269	2.7644		
	20	-	-	0.0029	-	0.0099	0.0164	0.0588	0.0516	0.0936	0.3453	0.2823	0.5199	1.8413	1.5759	2.6699		
	22.4	-	-	0.0026	-	0.0077	0.0128	0.0535	0.0444	0.0744	0.3005	0.2192	0.4130	1.4295	1.2269	2.1566		
S3	25	-	-	-	-	-	-	-	0.0225	0.0413	0.0705	0.1263	0.2308	0.3925	0.7303	1.3073	2.1930	3.9525
	28	-	-	-	-	-	-	-	0.0195	0.0355	0.0608	0.1093	0.2000	0.3390	0.6258	1.1173	1.8748	3.3368
	31.5	-	-	-	-	-	-	-	0.0198	0.0360	0.0615	0.1090	0.2008	0.3403	0.6398	1.1490	1.8940	3.4198
	35.5	-	-	-	-	-	-	-	0.0140	0.0260	0.0443	0.0808	0.1473	0.2498	0.4603	0.8165	1.3610	2.5735
	40	-	-	-	-	-	-	-	0.0110	0.0200	0.0343	0.0653	0.1150	0.1948	0.3605	0.6355	1.0770	1.9133
	45	-	-	-	-	-	-	-	0.0103	0.0190	0.0323	0.0618	0.1085	0.1878	0.3395	0.5988	0.9855	1.7985
	50	-	-	-	-	-	-	-	0.0080	0.0150	0.0263	0.0440	0.0823	0.1415	0.2623	0.4643	0.7860	3.7035
	56	-	-	-	-	-	-	-	0.0068	0.0128	0.0220	0.0380	0.0700	0.1218	0.2243	0.3945	0.6665	3.2085
	63	-	-	-	-	-	-	-	0.0073	0.0138	0.0240	0.0395	0.0748	0.1280	0.2390	0.4235	0.7093	1.2845
	71	-	-	-	-	-	-	-	0.0063	0.0115	0.0200	0.0345	0.0640	0.1110	0.2058	0.3623	0.6058	1.0883
	80	-	-	-	-	-	-	-	0.0053	0.0098	0.0178	0.0288	0.0545	0.0930	0.1750	0.3115	0.5100	0.9308
	90	-	-	-	-	-	-	-	0.0053	-	0.0150	0.0248	0.0386	0.0798	0.1520	0.2182	0.4403	0.8135
	100	-	-	-	-	-	-	-	0.0045	-	0.0148	0.0245	0.0353	0.0793	0.1510	0.2013	0.4420	0.8073
112	-	-	-	-	-	-	-	0.0038	-	0.0118	0.0200	0.0324	0.0640	0.1215	0.1857	0.3620	0.6558	
S4	125	-	-	-	-	-	-	-	-	-	-	0.0162	0.0297	0.0510	0.0936	0.1713	0.2862	0.5244
	140	-	-	-	-	-	-	-	-	-	-	0.0135	0.0252	0.0432	0.0852	0.1452	0.2454	0.4509
	160	-	-	-	-	-	-	-	-	-	-	0.0132	0.0246	0.0423	0.0831	0.1419	0.2394	0.4401
	180	-	-	-	-	-	-	-	-	-	-	0.0105	0.0195	0.0342	0.0609	0.1077	0.1845	0.3405
	200	-	-	-	-	-	-	-	-	-	-	0.0126	0.0237	0.0408	0.0804	0.1368	0.2301	0.4233
	224	-	-	-	-	-	-	-	-	-	-	0.0102	0.0189	0.0330	0.0585	0.1038	0.1773	0.3273
	250	-	-	-	-	-	-	-	-	-	-	0.0129	0.0240	0.0408	0.0741	0.1368	0.2265	0.4185
	280	-	-	-	-	-	-	-	-	-	-	0.0111	0.0204	0.0354	0.0696	0.1182	0.1980	0.3675
	315	-	-	-	-	-	-	-	-	-	-	0.0090	0.0162	0.0288	0.0501	0.0891	0.1521	0.2832
	355	-	-	-	-	-	-	-	-	-	-	0.0075	0.0138	0.0243	0.0429	0.0762	0.1323	0.2445
	400	-	-	-	-	-	-	-	-	-	-	0.0063	0.0117	0.0213	0.0360	0.0654	0.1107	0.2079
	450	-	-	-	-	-	-	-	-	-	-	0.0063	0.0114	0.0204	0.0342	0.0651	0.1107	0.2076
	500	-	-	-	-	-	-	-	-	-	-	0.0057	-	0.0174	0.0288	-	0.0951	0.1806
560	-	-	-	-	-	-	-	-	-	-	0.0045	-	0.0138	0.0240	-	0.0771	0.1455	

GD Square values (kg-m²) - K2, K3, K4

Type	i _N	Gear unit Size														
		11	13	14	15	16	17	18	19	20	21	22	23	24	25	26
K2	5	-	-	-	0.0329	-	-	0.2005	-	-	1.1220	-	-	6.4715	-	-
	5.6	-	0.0114	-	0.0318	-	-	0.1929	-	-	1.0842	1.8418	-	6.2213	10.9504	-
	6.3	0.0038	0.0110	-	0.0306	-	0.1044	0.1856	-	0.5898	1.0478	1.7804	3.2670	5.9807	10.5095	20.1875
	7.1	0.0038	0.0105	-	0.0296	-	0.1001	0.1785	-	0.5673	1.0125	1.7210	3.1574	5.7494	10.0863	19.5288
	8	0.0036	0.0102	-	0.0285	-	0.0968	0.1724	-	0.5483	0.9789	1.6631	3.0548	5.5805	9.7674	18.9378
	9	0.0030	0.0083	-	0.0233	-	0.0783	0.1409	-	0.4449	0.7886	1.3380	2.4473	4.4955	7.8683	15.2442
	10	0.0024	0.0069	-	0.0192	-	0.0644	0.1164	-	0.3663	0.6435	1.0830	1.9863	3.6575	6.4106	12.4238
	11.2	0.0021	0.0057	-	0.0158	-	0.0525	0.0963	-	0.3015	0.5253	0.8841	1.6217	2.9885	5.2424	10.1013
	12.5	0.0018	0.0048	-	0.0131	-	0.0435	0.0807	-	0.2499	0.4317	0.7197	1.3122	2.4492	4.2938	8.2713
	14	0.0015	0.0041	-	0.0108	-	0.0362	0.0680	-	0.2100	0.3567	0.5903	1.0761	2.0273	3.5610	6.8516
	16	0.0014	0.0035	-	0.0092	-	0.0299	0.0567	-	0.1754	0.2991	0.4905	0.8919	1.6979	2.9880	5.7323
	18	0.0012	0.0030	-	0.0078	-	0.0254	0.0485	-	0.1488	0.2487	0.4044	0.7304	1.4079	2.4804	4.8758
	20	0.0011	0.0027	-	0.0173	-	0.0222	0.0870	-	0.1310	0.5048	0.3491	0.6252	2.9313	2.1473	4.1493
	22.4	0.0009	-	-	0.0165	0.0285	0.0194	0.0803	0.1498	0.1152	0.4795	0.8760	0.5352	2.7888	4.7188	3.5311
K3	25	-	-	0.0078	0.0130	0.0228	0.0388	0.0648	0.1180	0.2135	0.3815	0.6983	1.2320	2.1905	3.5663	6.6940
	28	-	-	0.0090	0.0153	0.0268	0.0415	0.0760	0.1383	0.2488	0.4418	0.8095	1.4475	2.5883	4.3400	7.9568
	31.5	-	-	0.0073	0.0120	0.0213	0.0323	0.0595	0.1090	0.1963	0.3515	0.6458	1.1413	2.0323	3.4060	6.1613
	35.5	-	-	0.0060	0.0098	0.0173	0.0265	0.0485	0.0885	0.1595	0.2863	0.5233	0.9300	1.6493	2.7660	5.0145
	40	-	-	0.0050	0.0080	0.0140	0.0215	0.0395	0.0718	0.1293	0.2340	0.4258	0.7548	1.3283	2.2255	4.0178
	45	-	-	0.0040	0.0065	0.0118	0.0175	0.0325	0.0588	0.1060	0.1935	0.3538	0.6210	1.0838	1.8013	3.2613
	50	-	-	0.0035	0.0055	0.0098	0.0145	0.0268	0.0483	0.0865	0.1603	0.2938	0.5110	0.8845	1.4708	2.6635
	56	-	-	0.0030	0.0045	0.0080	0.0120	0.0223	0.0398	0.0718	0.1340	0.2460	0.4233	0.7268	1.1975	2.1560
	63	-	-	0.0025	0.0038	0.0068	0.0100	0.0183	0.0335	0.0598	0.1130	0.2083	0.3553	0.6000	0.9820	1.7690
	71	-	-	0.0023	0.0033	0.0058	0.0085	0.0153	0.0278	0.0493	0.0943	0.1740	0.2965	0.5030	0.8160	1.4675
	80	-	-	0.0023	-	0.0058	0.0083	0.0234	0.0275	0.0490	0.1057	0.1730	0.2948	0.6429	0.8108	1.4575
	90	-	-	0.0020	-	0.0050	0.0073	0.0188	0.0238	0.0418	0.0847	0.1495	0.2498	0.5002	0.6688	1.1943
	100	-	-	0.0018	-	-	0.0063	0.0150	0.0210	0.0365	0.0678	0.1293	0.2198	0.3891	0.6774	1.0233
	K4	112	-	-	-	-	-	0.0093	0.0120	0.0168	0.0306	0.0543	0.0972	0.1716	0.3027	0.5274
125		-	-	-	-	-	0.0087	0.0108	0.0147	0.0270	0.0480	0.0855	0.1515	0.2661	0.4665	0.8379
140		-	-	-	-	-	0.0099	0.0117	0.0150	0.0276	0.0483	0.0939	0.1599	0.2745	0.4833	0.8631
160		-	-	-	-	-	0.0078	0.0093	0.0120	0.0219	0.0393	0.0693	0.1218	0.2124	0.3744	0.6711
180		-	-	-	-	-	0.0093	0.0105	0.0126	0.0234	0.0414	0.0810	0.1359	0.2313	0.4101	0.7293
200		-	-	-	-	-	0.0075	0.0084	0.0102	0.0186	0.0336	0.0591	0.1032	0.1782	0.3171	0.5658
224		-	-	-	-	-	0.0051	0.0057	0.0072	0.0129	0.0234	0.0402	0.0726	0.1257	0.2268	0.4020
250		-	-	-	-	-	0.0048	0.0054	0.0066	0.0120	0.0219	0.0372	0.0675	0.1161	0.2109	0.3729
280		-	-	-	-	-	0.0048	0.0054	0.0063	0.0114	0.0207	0.0351	0.0633	0.1083	0.1977	0.3486
315		-	-	-	-	-	0.0048	0.0051	0.0060	0.0108	0.0195	0.0330	0.0597	0.1023	0.1875	0.3300
355		-	-	-	-	-	0.0048	0.0051	0.0057	0.0102	0.0186	0.0315	0.0570	0.0978	0.1794	0.3156
400		-	-	-	-	-	0.0045	0.0048	0.0054	0.0099	0.0180	0.0303	0.0549	0.0936	0.1725	0.3027
450		-	-	-	-	-	0.0045	-	0.0054	0.0099	-	0.0303	0.0546	-	0.1722	0.3024
500		-	-	-	-	-	0.0045	-	0.0051	0.0096	-	0.0294	0.0534	-	0.1680	0.2943
560	-	-	-	-	-	0.0039	-	0.0045	0.0081	-	0.0246	0.0426	-	0.1353	0.2538	



Gear Hobbing Machine
(Internal / External – 2500 mm Dia)



Spiral Bevel 'Hard Cut' Machine (1100 mm Dia)



Profile Grinding Machine
(Internal / External – 3000 mm Dia)



3000mm x 2000mm CNC
Hori www.famcocorp.com
E-mail: info@famcocorp.com
[@famco_group](https://www.instagram.com/famco_group)



Tel: +91-48000049
Fax: +91-44994642

تهران، کیلومتر ۲۱ بزرگراه لشگری (جاده مخصوص کرج)
روبروی پالایشگاه نفت پارس، پلاک ۱۲

National Branches :

Ahmedabad

Tel: +91 79 26406683/26406684/26406685
 Fax: +91 79 2640 1363
 Email : salesahd@elecon.com

Bangalore

Tel: +91 80 222 82 925 / 222 60 219
 Fax: +91 80 2228 1834
 Email : salesbgl@elecon.com

Bilaspur

Tel: +91 7752 247723 / 247625
 Fax: +91 7752 247720
 Email : salesbil@elecon.com

Chennai

Tel: +91 44 24349237/24349497/24322455
 Fax: +91 44 2434 9643
 Email : saleschn@elecon.com

Indore

Tele Fax: + 91 731 257 6100
 Email : salesindr@elecon.com

Kolkata

Tel: +91 33 2476 1861 / 2476 0876
 Fax: +91 33 2476 1831
 Email : saleskol@elecon.com

Madurai

Tel: +91 4549 293488
 Email : salesmadu@elecon.com

Nagpur

Tel: +91 712 6642600 / 6642 601
 Fax: +91 712 6642 622
 Email : salesnag@elecon.com

Mumbai

Tel: +91 22 22821315/22820725/22821365
 Fax: +91 22 2287 0791
 Email : salesbom@elecon.com

New Delhi

Tel: +91 11 2341 4340 / 2341 4341
 Fax: +91 11 2370 9046
 Email : salesdel@elecon.com

Pune

Tel: +91 20 4019 1400
 Fax: +91 20 4019 1411
 Email : salespune@elecon.com

Raipur

Tele Fax: +91 771 2259 321 /23/24/30
 Email : salesrai@elecon.com

Secunderabad

Tel: +91 40 2784 6984 / 2784 5250
 Fax: +91 40 2784 8317
 Email : salessec@elecon.com

Vadodara

Tel: +91 265 2313 670
 Tele Fax: 91 265 2312 972 / 2312 980
 Email : salesvad@elecon.com

Vallabh Vidyanagar

Tel: +91 02692-231125 / 227559/227549/ 227560
 E mail : salesvvn@elecon.com

International Network :

MIDDLE EAST :

ELECON MIDDLE EAST FZCO, Dubai
 Phone : +97 146 091 424, +97 146 091 425
 Fax : +97 146 091 426
 E-mail : salesme@elecon.com

FAR EAST :

ELECON SINGAPORE PTE. LTD.
 Phone : +65 622 782 58
 Fax : +65 622 789 42
 E-mail : salesap@elecon.com

benzlers

SWEDEN

AB Benzlers
 Tel: + 46 42 18 68 00
 Fax: + 46 42 21 88 03
 info@benzlers.com
 www.benzlers.com

FINLAND

O.Y. Benzler AB
 Tel: +358 9 340 1716
 Fax: +358 10 296 2072
 info@benzlers.com
 www.benzlers.com

NETHERLANDS

Benzler-TBA BV
 Tel : +31 077 324 5900
 Fax: +31 077 324 5901
 mail@benzlers.com
 www.benzlers.com

DENMARK

Benzler Transmission A/S
 Tel: +45 36 34 0300
 info@benzlers.com
 www.benzlers.com

GERMANY

Benzler Antriebstechnik
 Gmbh
 Tel: +49 0800 350 4000
 Fax: +49 0800 350 4001
 mail@benzlers.com
 www.benzlers.com

1000/06/2013



Manufactured by:

ELECON ENGINEERING CO. LTD.

Post Box # 6, Anand - Sojitra Road, Vallabh Vidyanagar - 388 120, Gujarat, INDIA

Tele. : +91 91 2692 236 469 / 236 513, Fax : +91 2692 227 484 E-mail : infogear@elecon.com

www.famcocorp.com

E-mail: info@famcocorp.com

@famco_group

Tel: +91 - 4 8 0 0 0 0 4 9

Fax : +91 - 4 4 9 9 4 6 4 2

تهران، کیلومتر ۲۱ بزرگراه لشگری (جاده مخصوص کرج)

روبروی پالایشگاه نفت پارس، پلاک ۱۲