

# Cast Iron Valves

JIS 5K/10K, Class 125



## STANDARD PRODUCTION RANGE

Valve Type	Nominal Pressure	Fig. No.	Construction (Note)	Page
Gate valves	JIS 5K	5FCM	B.B./O.S.&Y.	4
	JIS 10K	10FCL	B.B./O.S.&Y.	4
	JIS 10K	10FCLS	B.B./O.S.&Y.	4
	JIS 10K	10FCLU	B.B./O.S.&Y.	4
	JIS 10K	10FCWI	B.B./I.S./N.R.S.	5
	10K	10FCHI	B.B./I.S./N.R.S.	5
	Class 125	125FCL	B.B./O.S.&Y.	6
	Class 125	125FCLS	B.B./O.S.&Y.	6
	Class 125	125FCWI	B.B./I.S./N.R.S.	6
Globe valves	JIS 10K	10FCJ	B.B./O.S.&Y.	8
	JIS 10K	10FCJS	B.B./O.S.&Y.	8
	JIS 10K	10FCJU	B.B./O.S.&Y.	8
	Class 125	125FCJ	B.B./O.S.&Y.	8
	Class 125	125FCJS	B.B./O.S.&Y.	8
Check valves	JIS 10K	10FCO	Bolted cover	9
	JIS 10K	10FCOS	Bolted cover	9
	JIS 10K	10FCOU	Bolted cover	9
	Class 125	125FCO	Bolted cover	9
	Class 125	125FCOS	Bolted cover	9
	10K	10FWZ	Wafer type	10
Strainers	10K	10FCY	Bolted cover	10
	Class 125	125FCY	Bolted cover	11
Ball valves	10K	10FCT	Full bore	12
	10K	10FCTB	Full bore	12
	10K	10FCTR	Reduced bore	13
	10K	10FCTB2L	Full bore, 3-way	13
	10K	10FCTR2L	Reduced bore, 3-way	13
	Class 125	125FCTB	Full bore	14
	Class 125	125FCTR	Reduced bore	14

### Product Coding

EX:

**125**  
↓  
1
 

**FC**  
↓  
2
 

**L**  
↓  
3
 

**S**  
↓  
4

- 1 Nominal pressure  
 125 ..... Class 125  
 5 ..... JIS 5K  
 10 ..... JIS 10K

- 2 Symbol of shell material  
 FC ..... Cast iron

- 3 Type of valve  
 L & M ..... Gate valve  
 WI & HI ... Gate valve with indicator  
 J ..... Globe valve  
 O ..... Check valve  
 Y ..... Strainer  
 TB ..... Full port ball valve  
 2L ..... 3-way ball valve

- 4 Trim material  
 None ..... Bronze trim  
 U ..... 18-8 stainless steel  
 S ..... 13Cr stainless steel

NOTE

**B.B.** ..... Bolted bonnet

**O.S.&Y** ... Outside screw & yoke

**I.S.** ..... Inside screw

**N.R.S.** ..... Non-rising stem



## Conditions of Fluids and Maximum Permissible Pressures

Unit: MPa

Standards	5K	10K			10K			
Nominal pressure	JIS B2031	JIS B2031			KITZ standard			
Valve type	Outside screw gate valve	Outside screw gate valve	Globe valve, Swing check valve	Inside screw gate valve	Valve 350 A or more	FC300 valve		
Disc seat structure	Press-fit seat	Screw seat	Screw seat		Press-fit seat	Screw seat	Press-fit seat	
Main section	CAC406	CAC 406 13 chrome 18-8 stainless steel	CAC 406	13 chrome 18-8 stainless steel	CAC 406	CAC 406 13 chrome 18-8 stainless steel	CAC 406 13 chrome	
Maximum permissible working pressure	Steady flow below 120 degrees in centigrade	0.7	1.4	1.4	–	1.4	1.0	
	Oil, pulsating flow and water below 120 degrees in centigrade	0.5	1.0	1.0	–	1.0	0.9	
	Saturated steam*1	0.2	0.7	0.7	–	0.2	0.7	
	Gas below 120 degrees in centigrade*2	0.2	0.2	0.2	–	0.2	0.2	
	120 degrees in centigrade	–	–	–	1.4	–	–	–
	220 degrees in centigrade	–	–	–	1.0	–	–	–

\*1 When the main section is made of 18-8 stainless steel and used for steam piping, it is necessary to weld hardened metal cladding on the seat surface. Please designate the same together with the steam specification.

When it is used for saturated steam at a pressure of 0.5 MPa or more, please designate accordingly.

\*2 Such gases as set forth in the High Pressure Gas Safety Act shall be excluded.  
Gases—Gases other than flammable and toxic gases

## Basic Design Specifications

Nominal Pressure	JIS5K/10K	Class 125	10K
Face-to-face dimension	JIS B 2031	ASME B 16.10	KITZ Std.
End flange dimension	JIS B 2239	ASME B 16.1	JIS B 2239
Wall thickness	JIS B 2031	KITZ Std.	

## Material Specifications for Grey Iron Casting

Mechanical Properties	JIS materials		
	FC200	FC250	FC300
Tensile strength (N/mm <sup>2</sup> ) min.	200	250	300
Brinell hardness (HB) max.	235	248	269
ASTM A126 Class B	Tensile strength (min)		31ksi
Transverse test requirement	Face at center, min.		3,300 lb
	Deflection at center, min.		0.12in

## Class 125 Valves Pressure-Temperature Ratings

## Maximum Allowable Non-Shock Pressure

Temperature	Class 125	
	Size 1 – 12	Size 14 – 24
°C	bar	
-29 to 65	13.8	10.3
80	13.3	9.8
100	12.7	9.2
120	12.1	8.6
140	11.5	8.0
160	10.8	7.4
178※	–	6.9

※178°C to reflect the temperature of saturated steam at 8.6 bar.

## Simplified Material Indication (as referred to on each page)

**Bronze trim** : Iron body with bronze trim

**13 Cr. trim** : Iron body with 13 Cr. trim

**18-8 trim** : Iron body with 18 Cr.-8 Ni trim

## Certification by JIS Mark

Industrial Standardization Law of Japan provides an effective measure to promote the introduction of high-level quality assurance system of manufacture and processing. Wherever KITZ valves are identified with JIS Mark, it is officially certified that such valves are produced under strict quality assurance procedures and practices to satisfy the designated quality level stably and constantly.

## Valve Position Indicators



A valve position indicator is provided on gate valves with inside screw design as illustrated here. Opening or closing a valve does not move the vertical position of the stem. Instead, the position indicator visually indicates three valve operating positions—fully opened, fully closed, or half opened.

## Trim Materials

KITZ cast iron valves are provided with one of the three trim materials given in the table below for versatility of service applications.

Color codes are given on a name plate of gate or globe valves and on the cover of swing check valves.

Trim Material	Color Coding	Suffix of Fig.
■ Bronze seats / Brass stem	None	–
■ 13 Cr. seats / stem	Orange	S
■ 18-8 seats / stem	Green	U

Outside Screw (O.S.) Valves and Inside Screw (I.S.) Valves

**Outside Screw Gate Valve**

**Inside Screw Gate Valve**

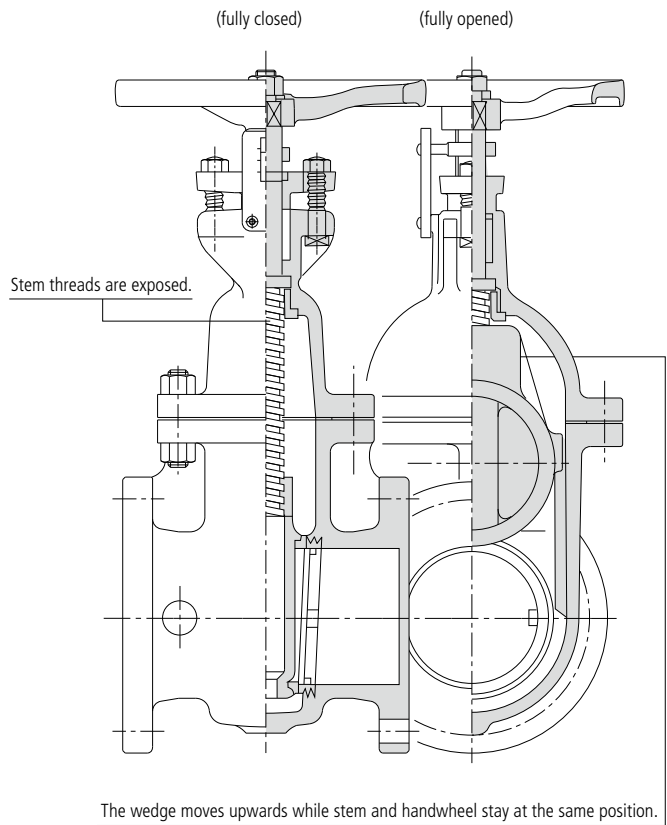
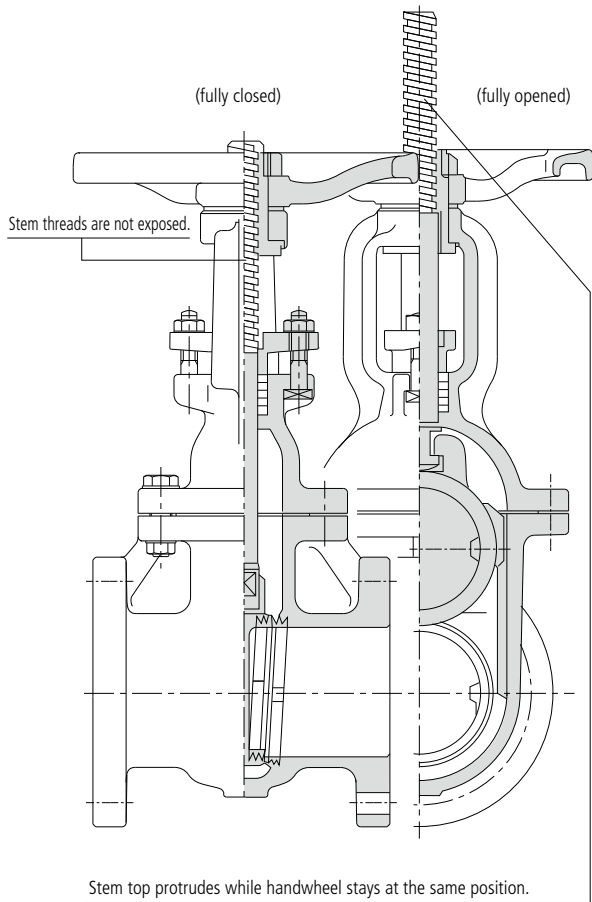

**Outside Screw Gate Valves**

Stem threads are not exposed to the fluid, and valve opening operation moves the stem upwards while the handwheel stays at the same position. The Valve operating position can be visually determined by observing the stem travel KITZ Fig. FCM, FCL, FCLS, and FCLU are designed this way.

**Outside Screw Globe Valves**

The stem and handwheel move upwards or downwards at the same time, following valve opening or closing operation. All KITZ globe valves are provided with this design.

**Inside Screw Gate Valves**

Stem threads are exposed to the fluid. Opening the valve does not make the stem or handwheel move. Thus, the valve operating position is not visible. A position indicator is provided for this reason.

Inside screw gate valves are generally designed shorter than outside screw gate valves and the stem and handwheel always at the same position. For this feature, inside screw gate valves are widely employed for underground installation or service in narrow areas with limited room. KITZ Fig. FCWI and FCHI are designed this way.

**Asbestos-free Packings and Gaskets**

KITZ has led the industry in employing asbestos-free sealers for all cast iron valves, meeting the requirement of pollution-free valve materials. PTFE-impregnated glass fiber gland packings and compressed glass and aramid fiber gaskets are the standard sealers for KITZ cast iron valves.

**JIS 5K**

**GATE VALVE**

Bolted bonnet, outside screw & yoke, rising stem.

Designed to JIS B2031

**Fig. 5FCM**

- Bronze trim

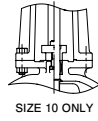
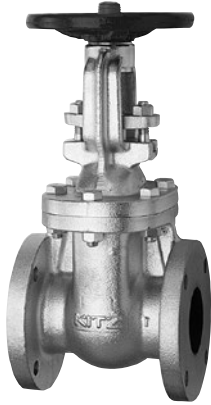

SIZE 10 ONLY

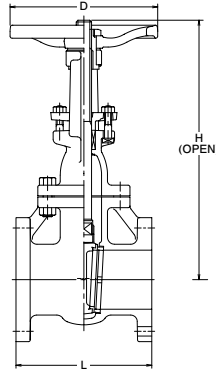

**Materials**

Parts	Material	JIS Spec.
Body	Cast Iron	FC200
Bonnet	Cast Iron	FC200
Stem	Forged Brass	C3771
Disc	Cast Iron	FC200
Disc seat ring	Cast Bronze	CAC406
Body seat ring	Cast Bronze	CAC406
Gland	Ductile Iron	FCD-5
Gland packing	Non-Asbestos Packing	
Gasket	Non-Asbestos Sheet Gasket	
Gland bolt/nut	Carbon Steel	
Bonnet bolt/nut	Carbon Steel	
Yoke sleeve	Cast Bronze	
Handwheel	Cast Iron	

For JIS Valves Pressure-Temperature Ratings MPa, refer to page 2.

**Dimensions**

Valve Size	B	2	2 1/2	3	4	5	6	8	10
L Face-to-face	A	50	65	80	100	125	150	200	250
H Height (OPEN)		160	170	180	200	220	240	260	300
D Diameter		328	382	436	532	627	726	919	1134
		160	170	170	225	225	250	280	350

**JIS 10K**

**GATE VALVE**

Bolted bonnet, outside screw & yoke, rising stem.

Designed to JIS B2031

**Fig. 10FCL**

- Bronze trim

**Fig. 10FCLS**

- Stainless steel trim (13 Cr.)

**Fig. 10FCLU**

- Stainless steel trim (18-8)

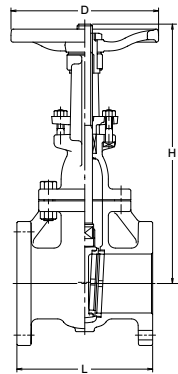
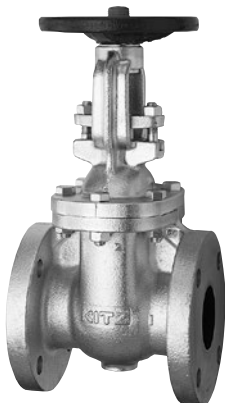

SIZE 10 & LARGER

**Materials**

Parts	Material	JIS Spec.		
		10FCL	10FCLS	10FCLU
Body	Cast Iron	FC200		
Bonnet	Cast Iron	FC200		
Stem	Forged Brass/Stainless Steel	C3771	403SS	304SS
Disc	Cast Iron	FC200		
Disc seat ring	Cast Bronze/Stainless Steel	CAC406	403SS	304SS
Body seat ring	Cast Bronze/Stainless Steel	CAC406	403SS	304SS
Gland	11/2 to 14 16 to 24	Ductile Iron	FCD-5	
Gland packing		Stainless Steel SUS403		
Gland packing		Non-Asbestos Packing		
Gasket		Non-Asbestos Sheet Gasket		
Gland bolt/nut		Carbon Steel		
Bonnet bolt/nut		Carbon Steel		
Yoke sleeve		Cast Bronze		
Handwheel	11/2 to 8 10 to 24	Cast Iron	FC250	
		Ductile Iron	FCD400-15	

For JIS Valves Pressure-Temperature Ratings MPa, refer to page 2.

**Dimensions**

Valve Size	B	1 1/2*	2	2 1/2	3	4	5	6	8	10	12	14*	16*	18*	20*	24*
L Face-to-face	A	40	50	65	80	100	125	150	200	250	300	350	400	450	500	600
H Height (OPEN)		165	180	190	200	230	250	270	290	330	350	381	406	432	457	508
D Diameter		306	343	389	462	547	648	759	956	1168	1363	1560	1795	1995	2230	2640
		160	170	170	200	250	280	300	350	400	450	500	600	600	680	760

\*JIS Mark is not applicable

**JIS 10K**

**GATE VALVE**

Bolted bonnet, inside screw with indicator, non-rising stem.

Designed to JIS B2031

**Fig. 10FCWI**

- Bronze trim



SIZE 8 & LARGER

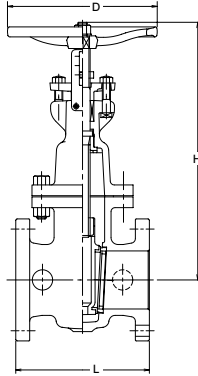

**Materials**

Parts	Material	JIS Spec.
Body	Cast Iron	FC200
Bonnet	Cast Iron	FC200
Stem	Forged Brass	C3771BD
Disc	Cast Iron	FC200
Disc seat ring	Cast Bronze	CAC406
Body seat ring	Cast Bronze	CAC406
Gland	Ductile Iron	FCD-5
Gland packing	Non-Asbestos Packing	
Gasket	Non-Asbestos Sheet Gasket	
Gland bolt/nut	Carbon Steel	
Bonnet bolt/nut	Carbon Steel	
Bonnet bushing	Cast Bronze	CAC406
Handwheel	1 1/2 to 8	Cast Iron
	10 to 12	Ductile Iron
		FCD400-15

For JIS Valves Pressure-Temperature Ratings MPa, refer to page 2.

**Dimensions**

Valve Size	B	1 1/2	2	2 1/2	3	4	5	6	8	10	12
	A	40*	50	65	80	100	125	150	200	250	300
L Face-to-face		165	180	190	200	230	250	270	290	330	350
H Height		285	313	344	401	444	517	577	693	814	925
D Diameter		160	180	180	200	250	280	300	350	400	450

\*No JIS Mark

**10K**

**GATE VALVE**

Bolted bonnet, inside screw with indicator, non-rising stem.

**Fig. 10FCHI**

- Bronze trim

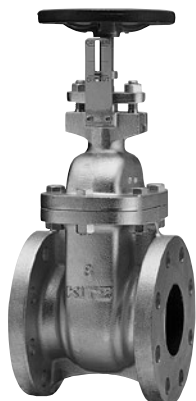

SIZE 8 & LARGER

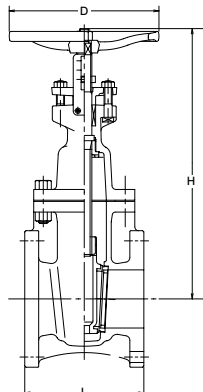

**Materials**

Parts	Material	JIS Spec.
Body	Cast Iron	FC300
Bonnet	Cast Iron	FC300
Stem	Forged Brass	C3771
Disc	1 1/2	Cast Bronze
	2 to 12	Cast Iron
Disc seat ring	Cast Bronze	CAC406
Body seat ring	Cast Bronze	CAC406
Gland	Ductile Iron	FCD400
Gland packing	Non-Asbestos Packing	
Gasket	Non-Asbestos Sheet Gasket	
Gland bolt/nut	Carbon Steel	
Bonnet bolt/nut	Carbon Steel	
Bonnet bushing	Cast Bronze	CAC406
Handwheel	Cast Iron	

Pressure-Temperature Ratings MPa, refer to page 2.

**Dimensions**

Valve Size	B	1 1/2	2	2 1/2	3	4	5	6	8	10	12
	A	40	50	65	80	100	125	150	200	250	300
L Face-to-face		140	146	159	165	171	190	210	241	273	305
H Height		210	250	285	350	400	460	515	635	760	870
D Diameter		140	140	160	160	180	225	225	300	350	350

**Class 125**

**GATE VALVE**

Bolted bonnet, outside screw & yoke, rising stem.

**Fig. 125FCL**

- Bronze trim



**Fig. 125FCLS**

- Stainless steel trim (13 Cr.)

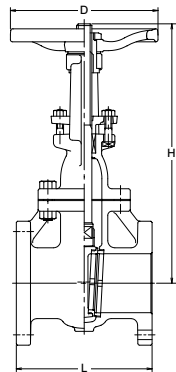

**Materials**

Parts	Material	ASTM Spec.	
		125FCL	125FCLS
Body	Cast Iron	FC200	
Bonnet	Cast Iron	FC200	
Stem	Forged Brass/Stainless Steel	C3771	A276 Type403
Disc	Cast Iron	FC200	
Disc seat ring	Cast Bronze/Stainless Steel	CAC406	A182 Gr.F6a
Body seat ring	Cast Bronze/Stainless Steel	CAC406	A182 Gr.F6a
Gland	Ductile Iron	FCD-5	
Gland packing	Non-Asbestos Packing		
Gasket	Non-Asbestos Sheet Gasket		
Gland bolt/nut	Carbon Steel		
Bonnet bolt/nut	Carbon Steel		
Yoke sleeve	Cast Bronze		
Handwheel	2 to 10	Cast Iron	
	12 & 14	Ductile Iron	

For Class 125 Valves Pressure-Temperature Ratings, refer to page 2.

**Dimensions**

Valve Size	NPS	2	2 1/2	3	4	5	6	8	10	12	14
	DN	50	65	80	100	125	150	200	250	300	350
L Face-to-face		178	190	203	229	254	267	292	330	356	381
H Height (OPEN)		328	382	436	532	627	726	919	1134	1363	1560
D Diameter		160	170	170	225	225	250	280	350	450	500

**Class 125**

**GATE VALVE**

Bolted bonnet, inside screw with indicator, non-rising stem.

**Fig. 125FCWI**

- Bronze trim

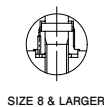
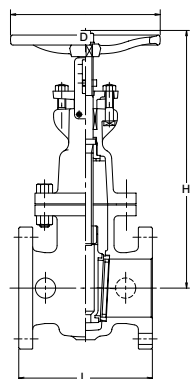
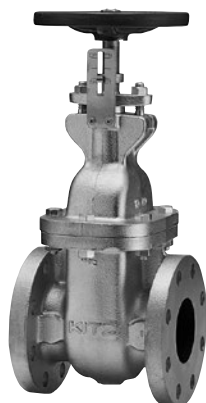

**Materials**

Parts	Material	ASTM Spec.
Body	Cast Iron	FC200
Bonnet	Cast Iron	FC300
Stem	Forged Brass	C3771
Disc	Cast Iron	FC300
Disc seat ring	Cast Bronze	CAC
Gland	Ductile Iron	FCD-5
Gland packing	Non-Asbestos Packing	
Gasket	Non-Asbestos Sheet Gasket	
Gland bolt/nut	Carbon Steel	
Bonnet bolt/nut	Carbon Steel	
Body seat ring	Cast Bronze	CAC406
Bonnet bushing	Cast Bronze	CAC406
Handwheel	Cast Iron	

For Class 125 Valves Pressure-Temperature Ratings, refer to page 2.

**Dimensions**

Valve Size	NPS	2	2 1/2	3	4	5	6	8	10	12
	DN	50	65	80	100	125	150	200	250	300
L Face-to-face		178	190	203	229	254	267	292	330	356
H Height		250	285	350	400	465	515	630	760	870
D Diameter		140	160	160	180	225	225	300	350	350



**Class 125**

**GATE VALVE**

Bolted bonnet, inside screw & yoke, non-rising stem.

**Fig. 125FCHI**

• Bronze trim



SIZE 8 ONLY

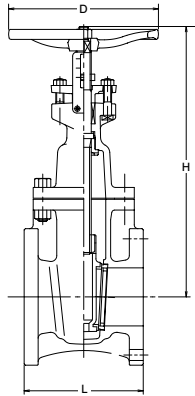

**Materials**

Parts	Material	ASTM Spec.	
Body	Cast Iron	FC300	
Bonnet	Cast Iron	FC300	
Stem	Forged Brass	C3771	
Disc	1 1/2 2 & larger	Bronze Cast Iron	CAC FC300
Disc seat ring	Cast Bronze	CAC	
Body seat ring	Cast Bronze	CAC	
Gland	Ductile Iron	FCD-5	
Gland packing	Non-Asbestos Packing		
Gasket	Non-Asbestos Sheet Gasket		
Gland bolt/nut	Carbon Steel		
Bonnet bolt/nut	Carbon Steel		
Bonnet bushing	Cast Bronze	CAC	
Handwheel	Cast Iron		

**Design Specifications**

Items	
Shell wall thickness and general valve design	KITZ Standard
Face-to-face dimensions, end-to-end dimensions	KITZ Standard
End flange dimensions, gasket contact facing	ASME B16.1 Class 125

For Class 125 Valves Pressure-Temperature Ratings, refer to page 2.

**Dimensions**

Valve Size	NPS DN	1 1/2	2	2 1/2	3	4	5	6	8	mm
L Face-to-face	140	146	159	165	171	190	190	210	241	
H Height		210	250	285	350	400	465	515	630	
D Diameter		140	140	160	160	180	225	225	300	

**Mounting of Seat Rings**

In case of KITZ cast iron gate valves, seat rings are mounted on the valve disc by means of either threading or press-fitting. For example, 10K outside screw gate valves are provided with threaded seat rings that are ideal for saturated steam service. Or, 10K inside screw gate valves are provided with mechanically press-fit seat rings by means of a patented special process to suit them also for saturated steam service. All KITZ cast iron globe and check valves are provided with threaded seat rings.

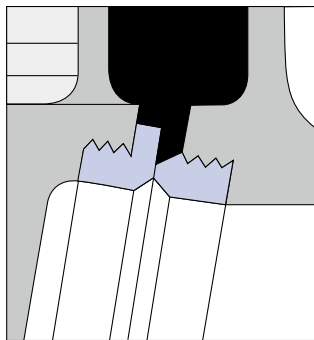

Threaded seat ring

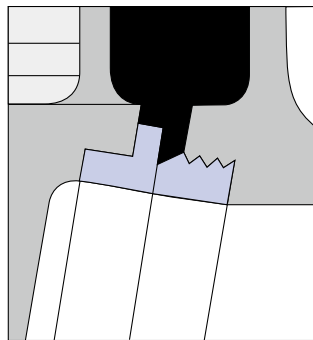

Press-fit seat ring

**JIS 10K**

**GLOBE VALVE**

Bolted bonnet, outside screw & yoke, rising stem.

Designed to JIS B2031

**Fig. 10FCJ**

- Bronze trim

**Fig. 10FCJS**

- Stainless steel trim (13 Cr.)

**Fig. 10FCJU**

- Stainless steel trim (18-8)

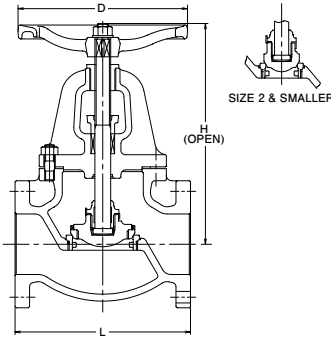

**Materials**

Parts	Material	JIS Spec.		
		10FCJ	10FCJS	10FCJU
Body	Cast Iron	FC200		
Bonnet	Cast Iron	FC200		
Stem	Forged Brass/Stainless Steel	C3771	403SS	304SS
Disc	11/4 & 2 Cast Bronze/Stainless Steel	CAC406	403SS	304SS
	2 1/2 & larger Cast Iron	FC200		
Disc seat ring	Cast Bronze/Stainless Steel	CAC406	403SS	304SS
Body seat ring	Cast Bronze/Stainless Steel	CAC406	403SS	304SS
Gland	Ductile Iron	FCD-5		
Gland packing	Non-Asbestos Packing			
Gasket	Flexible Graphite			
Gland bolt/nut	Carbon Steel			
Bonnet bolt/nut	Carbon Steel			
Yoke bushing	Cast Bronze			
Handwheel	1 1/2 to 6	Cast Iron		
	8 to 10	Ductile Iron		
	12 only	Ductile Iron	FC200	

For JIS Valves Pressure-Temperature Ratings MPa, refer to page 2.

**Dimensions**

Valve Size	B A	1 1/2	2	2 1/2	3	4	5	6	8	10	12
L Face-to-face		190	200	220	240	290	360	410	500	620	700
H Height (OPEN)		260	277	307	353	404	467	533	620	665	883
D Diameter		160	180	180	225	280	300	350	450	450	500

**CLASS 125**

**GLOBE VALVE**

Bolted bonnet, outside screw & yoke, rising stem.

**Fig. 125FCJ**

- Bronze trim

**Fig. 125FCJS**

- Stainless steel trim (13 Cr.)

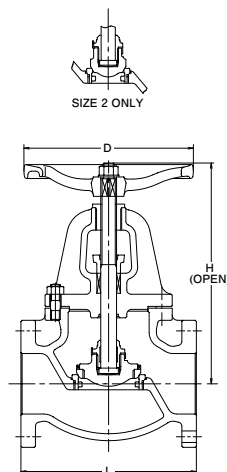

**Materials**

Parts	Material	ASTM Spec.	
		125FCJ	125FCJS
Body	Cast Iron	FC200	
Bonnet	Cast Iron	FC200	
Stem	Forged Brass/Stainless Steel	C3771	403SS
Disc	2 only Cast Bronze/Stainless Steel	CAC406	403SS
	2 1/2 & larger Cast Iron	FC200	
Disc seat ring	Cast Bronze/Stainless Steel	CAC406	403SS
Body seat ring	Cast Bronze/Stainless Steel	CAC406	403SS
Gland	Ductile Iron	FCD-5	
Gland packing	Non-Asbestos Packing		
Gasket	Non-Asbestos Sheet Gasket		
Gland bolt/nut	Carbon Steel		
Bonnet bolt/nut	Carbon Steel		
Yoke bushing	Cast Bronze		
Handwheel	2 to 6	Cast Iron	
	8 only	Ductile Iron	

For Class 125 Valves Pressure-Temperature Ratings, refer to page 2.

**Dimensions**

Valve Size	NPS DN	2 50	2 1/2 65	3 80	4 100	5 125	6 150	8 200
L Face-to-face		203	216	241	292	330	356	495
H Height (OPEN)		277	307	353	404	467	533	620
D Diameter		180	180	225	280	300	350	450

**JIS 10K**

**SWING CHECK VALVE**

Bolted cover, disc.

Designed to JIS B2031

**Fig. 10FCO**

• Bronze trim

**Fig. 10FCOS**

• Stainless steel trim (13 Cr.)

**Fig. 10FCOU**

• Stainless steel trim (18-8)

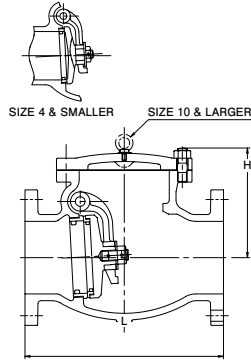

**Materials**

Parts	Material	JIS Spec.		
		10FCO	10FCOS	10FCOU
Body	Cast Iron	FC200		
Cover	Cast Iron	FC200		
Disc	1 1/2 to 4	Cast Bronze/Stainless Steel	CAC406	403SS 304SS
	5 & larger	Cast Iron	FC200	
Hinge pin	Forged Brass/Stainless Steel	C3771	403SS	304SS
Disc seat ring	Cast Bronze/Stainless Steel	CAC406	403SS	304SS
Body seat ring	Cast Bronze	CAC406	403SS	304SS
Arm	Stainless Steel	A351 Gr.CF8/SCS13A		
Gasket	Soft Steel			
Cover bolt/nut	Carbon Steel			

For JIS Valves Pressure-Temperature Ratings MPa, refer to page 2.

**Dimensions**

Valve Size	B	A	1 1/2*	2	2 1/2	3	4	5	6	8	10*	12*	14*
L Face-to-face			190	200	220	240	290	360	410	500	620	700	787
H Height			106	111	121	145	165	207	225	268	315	356	381

Only 12\* & 14\* for 10FCOS & 10FCOU. \*No JIS Mark

**CLASS 125**

**SWING CHECK VALVE**

Bolted cover, disc.

**Fig. 125FCO**

• Bronze trim

**Fig. 125FCOS**

• Stainless steel trim (13 Cr.)

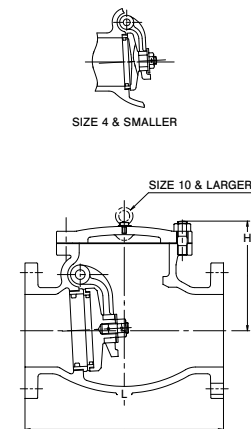

**Materials**

Parts	Material	ASTM Spec.	
		125FCO	125FCOS
Body	Cast Iron	FC200	
Cover	Cast Iron	FC200	
Disc	2 to 4	Cast Bronze/Stainless Steel	CAC406 403SS
	5 & larger	Cast Iron	FC200
Hinge pin	Forged Brass/Stainless Steel	C3771	403SS
Disc seat ring	Cast Bronze/Stainless Steel	CAC406	403SS
Body seat ring	Cast Bronze/Stainless Steel	CAC406	403SS
Arm	Stainless Steel	A351 Gr.CF8/SCS13A	
Gasket	Soft Steel		
Cover bolt/nut	Carbon Steel		

For Class 125 Valves Pressure-Temperature Ratings, refer to page 2.

**Dimensions**

Valve Size	NPS	DN	2	2 1/2	3	4	5	6	8	10	12	14
L Face-to-face			203	216	241	292	330	356	495	622	698	787
H Height (OPEN)			111	121	145	165	207	225	268	315	356	381

**10K**

**WAFER TYPE CHECK VALVE**

**Fig. 10FWZ**

• Bronze trim

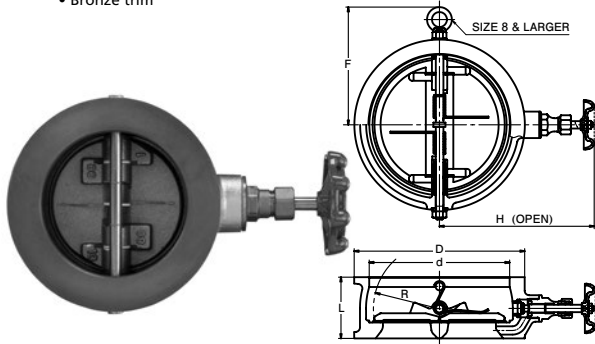

**Materials**

Parts	Material	JIS Spec.
Body	Cast Iron	FC250+NBR
Pin	Stainless Steel	304SS
Disc	Bronze	CAC406
Nut 6 to 18	Stainless Steel	304SS
Plug 11/2 to 5	Carbon Steel	S45CH

**Bypass Valve**

Parts	Material	JIS Spec.
Bonnet 11/2 to 5	Brass	C3771
6 to 18	Bronze	CAC406
Stem	Brass	C3531
Disc	Brass	C3531
Body seat ring	Brass	C3531
Grand packing	Asbestos-free	

**Design Specifications**

Items	
Shell wall thickness and general valve design	KITZ Standard
Face-to-face dimensions, end-to-end dimensions	KITZ Standard
End flange dimensions, gasket contact facing	Wafer Type (JIS 10K)

80°C Non-shock water: 1.4 MPa

80°C Water, oil, air: 1.0 MPa

**Dimensions**

Valve Size	B	1 1/2	2	2 1/2	3	4	5	6	8	10	12	14	16	18
L	A	40	50	65	80	100	125	150	200	250	300	350	400	450
H	Height (OPEN)	54	56	56	59	66	72	78	96	109	145	184	191	204
F		128	143	150	156	169	183	216	243	290	315	330	355	388
D		—	—	—	—	—	—	—	187	229	254	272	301	338
d		86	101	121	131	156	187	217	267	330	375	420	483	538
d		54	63	77	90	116	143	169	220	273	324	356	406	457
R		26	33	37	44	55	67	78	105	129	155	170	195	220

**10K**

**Y-PATTERN STRAINER**

Bolted cover, Y-pattern body, Punched stainless steel plate screen.

**Fig. 10FCY**

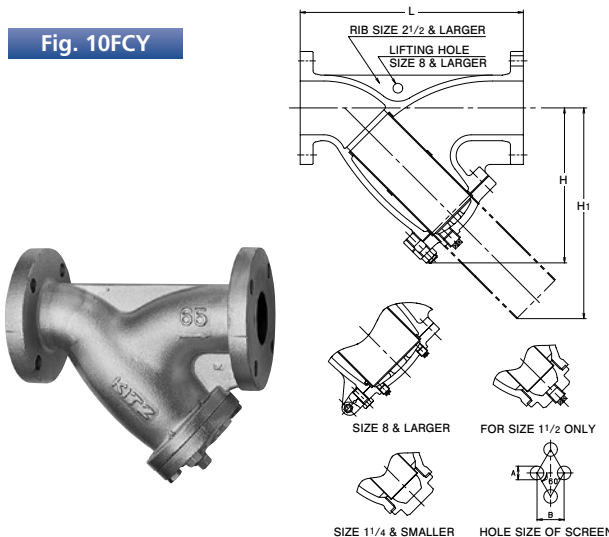

**Materials**

Parts	Material	JIS Spec.
Body	Cast Iron	FC200
Cap 3/8 to 11/2	Forged Brass	C3771
Cover 2 & larger	Cast Iron	FC200
Screen	Stainless Steel	304SS
Gasket	Non-Asbestos Sheet Gasket	
Cover bolt/nut	Carbon Steel	
Plug	Stainless Steel	304SS

**Screen dimensions**

Valve Size	A	B
3/8 to 2	1.4ø	2.4mm
2 1/2 to 5	1.5ø	2.5mm
6 & 8	3.0ø	5.0mm
10 to 14	5.0ø	7.0mm

120°C Non-shock water: 1.4 MPa

120°C Water, oil, air: 1.4 MPa

120°C Gas: 0.2 MPa, Saturated steam: 0.7 MPa

**Strainer dimensions**

Valve Size	B	3/8	1/2	3/4	1	1 1/4	1 1/2	2	2 1/2	3	4	5	6	8	10	12	14
L	A	10	15	20	25	32	40	50	65	80	100	125	150	200	250	300	350
L	Face-to-face	115	125	140	150	170	190	230	305	360	415	465	515	580	680	800	950
H	Height	46	57	63	77	90	100	138	208	237	280	325	370	457	536	625	741
H1		64	82	91	114	134	146	173	289	335	388	446	497	643	768	893	1047

**CLASS 125 Y-PATTERN STRAINER**

Bolted cover, Y-pattern body, Punched stainless steel plate screen.

**Fig. 125FCY**

• Bronze trim

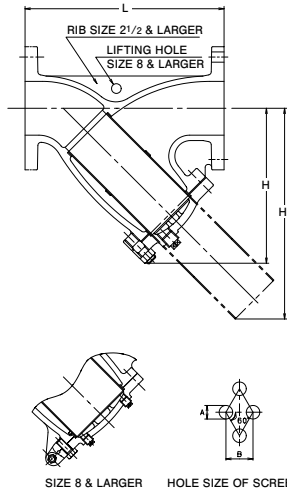

**Materials**

Parts	Material	ASTM Spec.
Body	Cast Iron	FC200
Cover	Cast Iron	FC200
Screen	Stainless Steel	304SS
Gasket	Non-Asbestos Sheet Gasket	
Cover bolt/nut	Carbon Steel	
Plug	Stainless Steel	304SS

**Screen dimensions**

Valve Size	A	B
2 only	1.4ø	2.4mm
2 1/2 to 5	1.5ø	2.5mm
6 & 8	3.0ø	5.0mm
10 to 14	5.0ø	7.0mm

**Design Specifications**

Items	
Shell wall thickness and general valve design	KITZ Standard
Face-to-face dimensions, end-to-end dimensions	KITZ Standard
End flange dimensions, gasket contact facing	ASME B16.1 Class125

For Class 125 Valves Pressure-Temperature Ratings, refer to page 2.

**Dimensions**

Valve Size	NPS	2	2 1/2	3	4	5	6	8	10	12	14	mm
	DN	50	65	80	100	125	150	200	250	300	350	
<b>L</b> Face-to-face		250	285	315	370	420	490	570	680	800	950	
<b>H</b> Height		168	212	242	284	325	370	440	515	600	740	
<b>H1</b>		208	289	335	388	446	497	589	694	818	993	

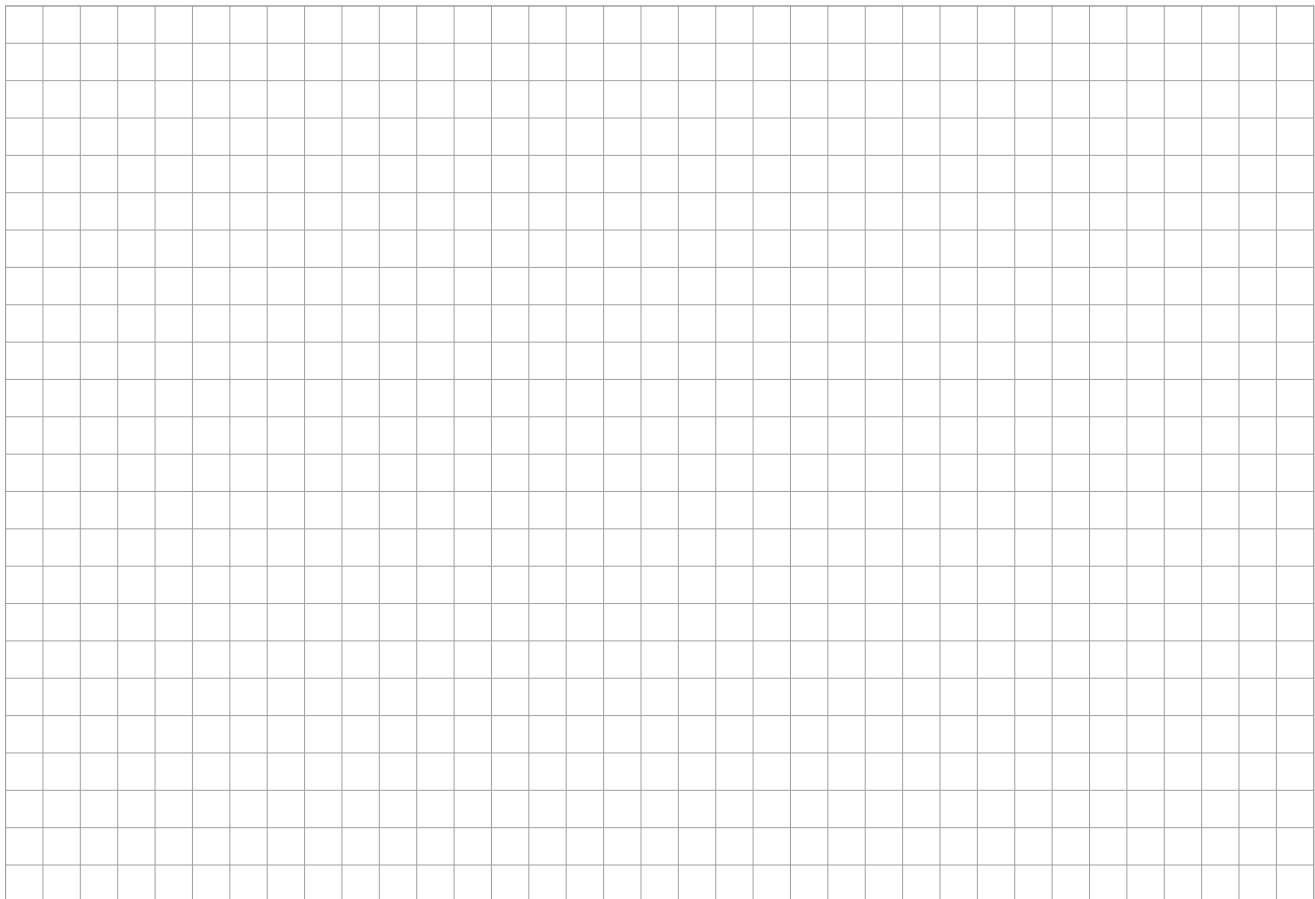

**10K**

**THREADED BALL VALVE (Full Bore)**

Fig. 10FCT

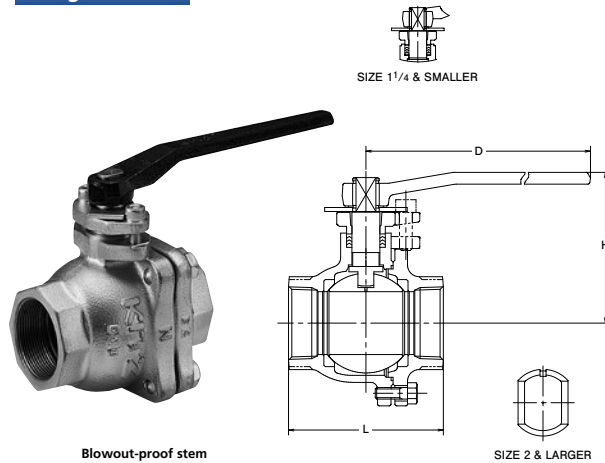

**Materials**

Parts	Material	JIS Spec.
Body	Cast Iron	FC200
Body cap	Cast Iron	FC200
Stem	Stainless Steel	4035S
Ball	Stainless Steel	3045S
Grand packing	PTFE	
Gasket	PTFE	
Ball seat	PTFE	
Cap bolt/nut	Carbon Steel	
Handle	Ductile Iron	FCD400-15

**Design Specifications**

Items	
Shell wall thickness and general valve design	KITZ Standard
Face-to-face dimensions, end-to-end dimensions	KITZ Standard
Threaded ends	JIS B0203

For Pressure-Temperature Ratings, refer to individual catalog(No.E-201).

**Dimensions**

Valve Size	B	3/8	1/2	3/4	1	1 1/4	1 1/2	2	2 1/2	3	mm
L Face-to-face	A	10	15	20	25	32	40	50	65	80	80
H Height		72	80	85	95	120	120	140	160	182	182
D Handle		71	102	105	125	130	115	120	155	165	165
		130	130	130	160	160	230	230	400	400	400

**10K**

**BALL VALVE (Full Bore)**

Fig. 10FCTB

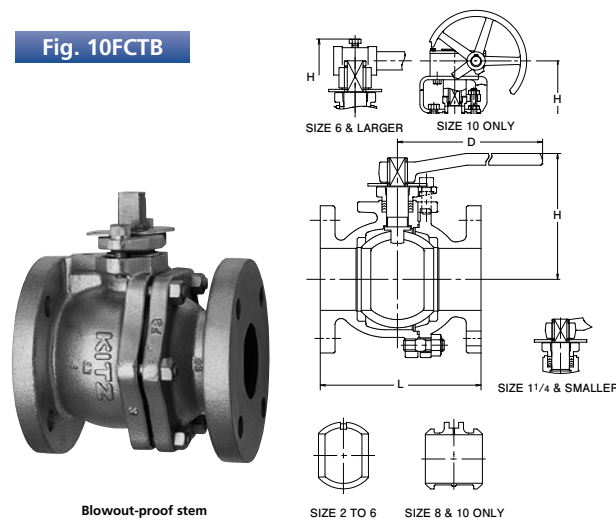

**Materials**

Parts	Material	JIS Spec.
Body	Cast Iron	FC200
Body cap	Cast Iron	FC200
Stem	Stainless Steel	4035S
Ball	Stainless Steel	3045S
Grand packing	PTFE	
Gasket	PTFE	
Ball seat	PTFE	
Cap bolt/nut	Carbon Steel	
Handle	Ductile Iron	FCD400-15

**Design Specifications**

Items	
Shell wall thickness and general valve design	KITZ Standard
Face-to-face dimensions, end-to-end dimensions	KITZ Standard
End flange dimensions, gasket contact facing	JIS B2239 10K

For Pressure-Temperature Ratings, refer to individual catalog(No.E-201).

**Dimensions**

Valve Size	B	1/2	3/4	1	1 1/4	1 1/2	2	2 1/2	3	4	5	6	8	10	mm
L Face-to-face	A	15	20	25	32	40	50	65	80	100	125	150	200	250*	250*
H Height		110	120	130	140	165	180	190	200	230	300	340	450	533	533
D Handle		102	105	124	128	114	121	154	163	199	219	292	352	477	477
		130	130	160	160	230	230	400	400	460	460	1000	1500	-	-

\*Note: Gear Operated. Contact KITZ or KITZ distributors for details.

**10K**

**BALL VALVE (Reduced Bore)**

Fig. 10FCTR



Blowout-proof stem

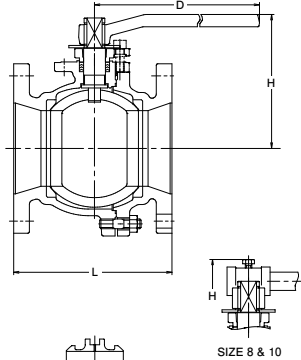

SIZE 10 ONLY

**Materials**

Parts	Material	JIS Spec.
Body	Cast Iron	FC200
Body cap	Cast Iron	FC200
Stem	Stainless Steel	403SS
Ball	Stainless Steel	304SS
Grand packing	PTFE	
Gasket	PTFE	
Ball seat	PTFE	
Cap bolt/nut	Carbon Steel	
Handle	Ductile Iron	FCD400-15

**Design Specifications**

Items	
Shell wall thickness and general valve design	KITZ Standard
Face-to-face dimensions, end-to-end dimensions*	JIS B2002
End flange dimensions, gasket contact facing	JIS B2239 10K

\*Nominal size 5, shall not be in accordance with JIS B2002

For Pressure-Temperature Ratings, refer to individual catalog(No.E-201).

**Dimensions**

Valve Size	B	5	6	8	10	mm
L Face-to-face	A	125	150	200	250	
H Height		200	220	295	355	
D Handle		460	460	1000	1500	

\*No JIS Mark

**10K**

**3-WAY BALL VALVE (Full or Reduced Bore)**

Fig. 10FCTB2L

• Full Bore:  
Size 1 1/2 to 4



Blowout-proof stem

Fig. 10FCTR2L

• Reduced Bore:  
Size 5 to 8

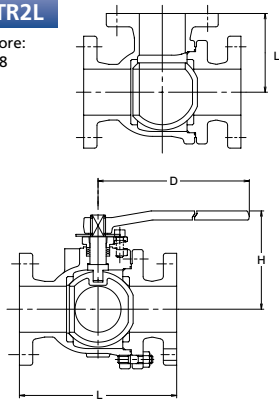

**Materials**

Parts	Material	JIS Spec.
Body	Cast Iron	FC200
Body cap	Cast Iron	FC200
Stem	Stainless Steel	403SS
Ball	Stainless Steel	304SS
Grand packing	PTFE	
Gasket	PTFE	
Ball seat	PTFE	
Cap bolt/nut	Carbon Steel	
Handle	Ductile Iron	FCD400-15

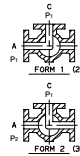

**Note:**

- Flow is between Ports "A" and "C" in Form 1. Flow is between Ports "B" and "C" in Form 2. Flow paths in Form 1 and Form 2 can be exchanged with each other.
- When the fluid pressure P2 in the closed path is higher than P1 in the open path, a little fluid leakage may occur in P1 through the ball seat of the closed path.

**Design Specifications**

Items	
Shell wall thickness	JIS B2031
Face-to-face dimensions, end-to-end dimensions	KITZ Standard
End flange dimensions, gasket contact facing	JIS B2239 10K

For Pressure-Temperature Ratings, refer to individual catalog(No.E-201).

**Dimensions**

Valve Size	B	1 1/2	2	2 1/2	3	4	5	6	8	mm
L Face-to-face	A	40	50	65	80	100	125	150	200	
L1		105	110	125	130	165	185	215	270	
H Height		115	120	155	165	200	205	225	295	
D Handle		230	230	400	400	460	460	460	1000	

## CLASS 125 BALL VALVE (Full Bore)

Fig. 125FCTB



Blowout-proof stem

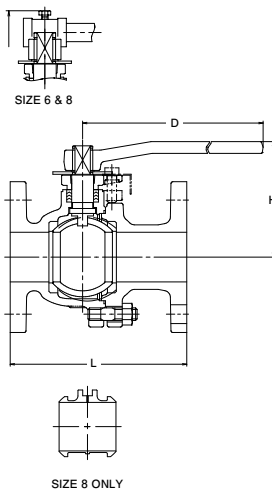

### Materials

Parts	Material	ASTM Spec.
Body	Cast Iron	A126 CL. B
Body cap	Cast Iron	A126 CL. B
Stem	Stainless Steel	403SS
Ball	Stainless Steel	304SS
Grand packing	PTFE	
Gasket	PTFE	
Ball seat	PTFE	
Cap bolt/nut	Carbon Steel	
Handle	Ductile Iron	

### Design Specifications

Items	
Shell wall thickness and general valve design	KITZ Standard
Face-to-face dimensions, end-to-end dimensions	ASME B16.10 Class150
End flange dimensions, gasket contact facing	ASME B16.1 Class125

For Pressure-Temperature Ratings, refer to individual catalog(No.E-201).

### Dimensions

Valve Size	NPS	2	2½	3	4	6	8	mm
	DN	50	65	80	100	150	200	
L	Face-to-face	178	190	203	229	394	457	
H	Height	120	155	165	200	295	355	
D	Handle	230	400	400	460	1000	1500	

## CLASS 125 BALL VALVE (Reduced Bore)

Fig. 125FCTR



Blowout-proof stem

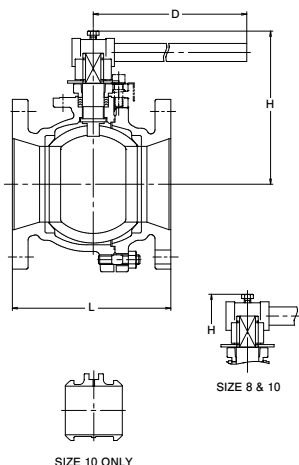

### Materials

Parts	Material	ASTM Spec.
Body	Cast Iron	A126 CL. B
Body cap	Cast Iron	A126 CL. B
Stem	Stainless Steel	403SS
Ball	Stainless Steel	304SS
Grand packing	PTFE	
Gasket	PTFE	
Ball seat	PTFE	
Cap bolt/nut	Carbon Steel	
Handle	Ductile Iron	

### Design Specifications

Items	
Shell wall thickness and general valve design	KITZ Standard
Face-to-face dimensions, end-to-end dimensions	ASME B16.10 Class150
End flange dimensions, gasket contact facing	ASME B16.1 Class125

For Pressure-Temperature Ratings, refer to individual catalog(No.E-201).

### Dimensions

Valve Size	NPS	6	8	10	mm
	DN	150	200	250	
L	Face-to-face	267	292	330	
H	Height	220	295	355	
D	Handle	460	1000	1500	



**PIPE FLANGE DIMENSIONS**

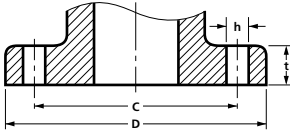

**Class 125 ASME B16.1 - 2010**

Nominal Size		D		C		t		h (Bolt Holes)		Bolting	
NPS	DN	in.	mm.	in.	mm.	in.	mm.	in.	mm.	Number	Diam. of Bolt
1	25	4.25	108	3.12	79.5	0.44	11.2	5/8	16	4	1/2
1 1/4	32	4.62	117	3.50	89.0	0.50	12.7	5/8	16	4	1/2
1 1/2	40	5.00	127	3.88	98.5	0.56	14.3	5/8	16	4	1/2
2	50	6.00	152	4.75	120.5	0.62	15.9	3/4	19	4	5/8
2 1/2	65	7.00	178	5.50	139.5	0.69	17.5	3/4	19	4	5/8
3	80	7.50	190	6.00	152.5	0.75	19.1	3/4	19	4	5/8
4	100	9.00	229	7.50	190.5	0.94	23.9	3/4	19	8	5/8
5	125	10.00	254	8.50	216.0	0.94	23.9	7/8	22	8	3/4
6	150	11.00	279	9.50	241.5	1.00	25.4	7/8	22	8	3/4
8	200	13.50	343	11.75	298.5	1.12	28.6	7/8	22	8	3/4
10	250	16.00	406	14.25	362.0	1.19	30.2	1	25	12	7/8
12	300	19.00	483	17.00	432.0	1.25	31.8	1	25	12	7/8
14	350	21.00	533	18.75	476.5	1.38	35.0	1 1/8	29	12	1
16	400	23.50	597	21.25	539.5	1.44	36.6	1 1/8	29	16	1
18	450	25.00	635	22.75	578.0	1.56	39.7	1 1/4	32	18	1 1/8
20	500	27.50	699	25.00	635.0	1.69	42.9	1 1/4	32	20	1 1/8
24	600	32.00	813	29.50	749.5	1.88	47.8	1 3/8	35	20	1 1/4

Remarks: Dimensions of mm in the above table are converted from inch dimension for your convenience.

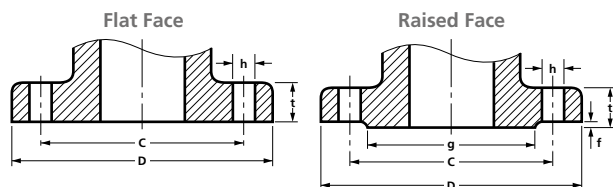
**PIPE FLANGE DIMENSIONS**

**JIS 5K Cast iron pipe flange dimensions JIS B2239 - 2013**

Unit: mm

Valve Size		D	C	g	t	h	f	Bolt	
B	A							Number	Diam.
1 1/2	40	120	95	75	16	15	2	4	M12
2	50	130	105	85	16	15	2	4	M12
2 1/2	65	155	130	110	18	15	2	4	M12
3	80	180	145	121	18	19	2	4	M16
4	100	200	165	141	20	19	2	8	M16
5	125	235	200	176	20	19	2	8	M16
6	150	265	230	206	22	19	2	8	M16
8	200	320	280	252	24	23	2	8	M20
10	250	385	345	317	26	23	2	12	M20
12	300	430	390	360	28	23	3	12	M20
14	350	480	435	403	30	25	3	12	M22

**JIS 10K Cast iron pipe flange dimensions JIS B2239 - 2013**

Unit: mm

Valve Size		D	C	g	t	h	f	Bolt	
B	A							Number	Diam.
3/8	10	90	65	46	14	15	1	4	M12
1/2	15	95	70	51	16	15	1	4	M12
3/4	20	100	75	56	18	15	1	4	M12
1	25	125	90	67	18	19	1	4	M16
1 1/4	32	135	100	76	20	19	2	4	M16
1 1/2	40	140	105	81	20	19	2	4	M16
2	50	155	120	96	20	19	2	4	M16
2 1/2	65	175	140	116	22	19	2	4	M16
3	80	185	150	126	22	19	2	8	M16
4	100	210	175	151	24	19	2	8	M16
5	125	250	210	182	24	23	2	8	M20
6	150	280	240	212	26	23	2	8	M20
8	200	330	290	262	26	23	2	12	M20
10	250	400	355	324	30	25	2	12	M22
12	300	445	400	368	32	25	3	16	M22
14	350	490	445	413	34	25	3	16	M22
16	400	560	510	475	36	27	3	16	M24
18	450	620	565	530	38	27	3	20	M24
20	500	675	620	585	40	27	3	20	M24
24	600	795	730	690	44	33	3	24	M30

**TEMPERATURE-PRESSURE TABLE FOR SATURATED-VAPOR**

Temperature			Pressure (abs.)			Pressure (G)		
Temperature °C	Pressure (abs.) MPa	Pressure (G) MPa	Pressure (abs.) MPa	Pressure (G) MPa	Saturation Temperature °C	Pressure (G) MPa	Pressure (abs.) MPa	Saturation Temperature °C
70	0.03	-0.07	0.09	-0.01	99.1	0	0.10	100.0
80	0.05	-0.05	0.19	0.09	119.6	0.09	0.19	120.1
90	0.07	-0.03	0.29	0.19	132.9	0.19	0.29	133.2
100	0.10	0	0.39	0.29	142.9	0.29	0.39	143.2
110	0.14	0.04	0.49	0.39	151.1	0.39	0.49	151.3
120	0.19	0.09	0.58	0.48	158.1	0.49	0.59	158.3
130	0.26	0.16	0.68	0.58	164.2	0.58	0.68	164.3
140	0.36	0.26	0.78	0.68	169.6	0.68	0.78	169.8
150	0.47	0.37	0.88	0.78	174.5	0.78	0.88	174.7
160	0.61	0.51	0.98	0.88	179.0	0.88	0.98	179.3
170	0.79	0.69	1.17	1.07	187.1	0.98	1.08	183.2
180	1.00	0.90	1.37	1.27	194.1	1.17	1.27	190.0
190	1.25	1.15	1.56	1.46	200.4	1.37	1.47	197.4
200	1.55	1.45	1.76	1.66	206.2	1.56	1.66	203.4
210	1.90	1.80	1.96	1.86	211.4	1.78	1.88	208.9
220	2.32	2.21	2.45	2.35	222.9	1.96	2.06	213.8
230	2.79	2.69	2.94	2.84	232.8	2.45	2.55	223.8
240	3.34	3.24	3.43	3.33	241.4	2.94	3.04	234.5
250	3.97	3.87	3.92	3.82	249.2	3.92	4.02	250.6
260	4.66	4.56	4.90	4.80	262.7	4.90	5.00	263.9
270	5.50	5.40	5.88	5.78	274.3	5.88	5.98	275.3
280	6.41	6.31	6.86	6.76	284.5	6.86	6.96	285.4
290	7.44	7.34	7.84	7.74	293.6	7.84	7.94	294.5
300	8.59	8.49	8.82	8.72	301.9	8.82	8.92	302.7
310	9.87	9.77	9.80	9.70	309.5	9.80	9.90	310.9
320	11.28	11.18	11.76	11.66	323.1	11.76	11.86	323.8
330	12.86	12.76	13.72	13.62	335.1	13.72	13.82	335.6
340	14.61	14.51	15.69	15.59	345.7	15.69	15.79	346.2
350	16.47	16.37	17.65	17.55	355.4	17.65	17.75	355.8
360	18.77	18.67	19.61	19.51	364.1	19.61	19.71	364.5
370	21.15	21.05	21.57	21.47	372.0	21.57	21.67	372.5



## CAUTION

Pressure-temperature ratings and other performance data published in this catalog have been developed from our design calculation, in-house testing, field reports provided by our customers and / or published official standards or specifications. They are good only to cover typical applications as a general guideline to users of KITZ products introduced in this catalog.

For any specific application, users are kindly requested to contact KITZ Corporation for technical advice, or to carry out their own study and evaluation for proving the suitability of these products to such an application. Failure to follow this request could result in property damage and/or personal injury, for which we shall not be liable.

While this catalog has been compiled with the utmost care, we assume no responsibility for errors, impropriety, or inadequacy. Any information provided in this catalog is subject to from-time-to-time change without notice for error rectification, product discontinuation, design modification, new product introduction or any other cause that KITZ Corporation considers necessary. This edition cancels all previous issues.

Read the instruction manual carefully before use.



## NOTICE

If any products designated as strategic material in the Foreign Exchange and Foreign Trade Law, Cabinet Order Concerning Control of Export Trade, Cabinet order Concerning Control of Foreign Exchange and other related laws and ordinances ("Foreign Exchange Laws") are exported to any foreign country or countries, an export license issued by the Japanese Government will be required under the Foreign Exchange Laws.

Further, there may be cases where an export license issued by the government of the United States or other country will be required under the applicable export-related laws and ordinances in such relevant countries.

The contract shall become effective subject to the fact that a relevant export license is obtained from the Japanese Government.

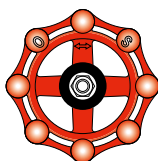

*A chrysanthemum-handle is a symbol of KITZ,  
the brand of valve reliability*

ISO 9001 certified since 1989

**KITZ**  
KITZ CORPORATION

1-10-1, Nakase, Mihama-ku, Chiba 261-8577, Japan  
International Sales Dept.  
Phone : 81-43-299-1730  
Fax : 81-43-299-0121

— Distributed by —