

Data sheet

ELIMINATOR® Hermetic filter drier

Types DML and DCL



All ELIMINATOR® driers have a solid core with binding material held to an absolute minimum.

There are two types of ELIMINATOR® cores. Type DML driers have a core composition of 100% Molecular Sieve, while type DCL contain 80% Molecular Sieve with 20% activated alumina.

ELIMINATOR® type DML driers are designed for applications requiring the highest moisture capacity.

ELIMINATOR® type DCL driers are designed for applications requiring high moisture capacity and acid adsorption capacity.

Available with solder (cu-plated steel connectors) and flare connections.

For other connections please contact your Danfoss Sales Representative.

Features

The Core type DML

- 100% Molecular Sieve core
- High drying capacity minimizing the risk of acid formation (hydrolysis)
- Recommended for use with HFC and HCFC refrigerants
- Will not deplete oil additives

The Core type DCL

- 80% Molecular Sieve with 20% activated alumina
- Perfect core blend for systems that operate at high condensing temperatures and require high drying capacity
- Recommended for use with HFC and HCFC refrigerants

The Shell

- PED approved for PS 46 bar
- Available with solder (Cu-plated steel connectors) and flare connections
- Corrosion resistant powder-painted finish. Special coating for marine applications available upon request
- Allows installation with any orientation provided the arrow is in the flow direction
- Available in sizes 3 – 75 cubic inches

The Filter

- 25 µm (0.001 in.) filter provides high retention with minimal pressure drop
- Thermally stable up to 120 °C

Data sheet | ELIMINATOR® Hermetic filter drier, types DML and DCL

Approvals

UL US, file no. SA 6398
PED 97/23/EC - a3p3
Compliant with ATEX hazard zone 2

⚠ Note: Only solder versions (cu-plated / pure copper) and connection sizes below 25 mm are approved for flammable refrigerants now.

Introduction

ELIMINATOR® Hermetic filter driers protect refrigeration and air-conditioning systems from moisture, acids, and solid particles.

With these contaminants eliminated, systems are safer from harmful chemical reactions and from abrasive impurities.

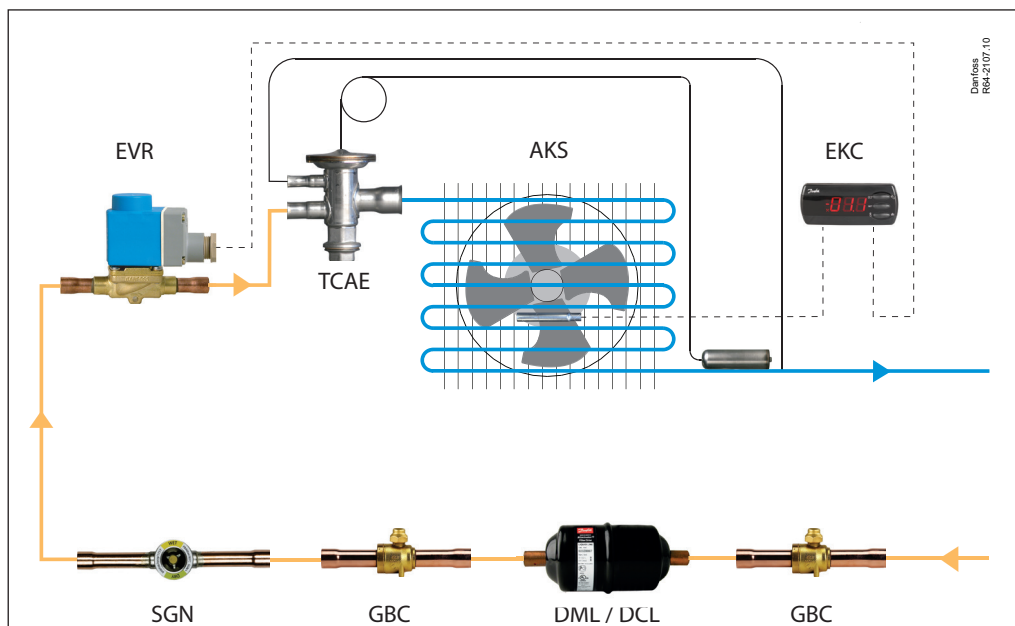

Technical data

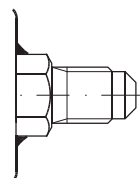

Flare connection

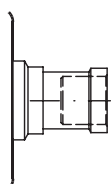

Solder connection
(cu-plated steel connectors)

Surface and volume

Filter	Solid core surface	Solid core volume	Filter drier volume (shell volume)	Filter drier volume (net volume)
	[cm ²]	[cm ³]	[l]	[l]
DML/DCL 03	82	41	0.08	0.038
DML/DCL 05	95	67	0.12	0.051
DML/DCL 08	131	104	0.17	0.065
DML/DCL 16	220	234	0.36	0.122
DML/DCL 30	378	494	0.72	0.224
DML/DCL 41	510	681	0.97	0.286
DML/DCL 60	756	988	1.34	0.352
DML/DCL 75	1019	1363	1.81	0.450

Filter	Acid capacity ¹⁾
	[g]
DCL 03	0.5
DCL 05	0.8
DCL 08	1.3
DCL 16	2.9
DCL 30	6.1
DCL 41	8.3
DCL 60	12.2
DCL 75	16.6

¹⁾ Adsorption capacity of oleic acid at 0.05 TAN (Total Acid Number).

Temperature range:
-40 – 70 °C

Maximum working pressure:
PS 46 bar

Technical data and capacities

Drying and liquid capacity , type DML

Type	Drying capacity [kg refrigerant ¹⁾														Liquid capacity [kW] ²⁾						
	R134a		R404A		R507		R22		R407C		R410A		R32		R134a	R404A	R507	R22	R407C	R410A	R32
	[°C]																				
	24	52	24	52	24	52	24	52	24	52	24	52	24	52	24	52					
DML 032/032s	5.0	4.7	5.3	5.1	5.4	5.0	5.0	4.7	5.0	4.6	4.5	4.2	4.6	4.2	6.70	5.01	4.86	7.45	7.09	7.43	10.86
DML 032.5s	5.0	4.7	5.3	5.1	5.4	5.0	5.0	4.7	5.0	4.6	4.5	4.2	4.6	4.2	9.59	6.97	6.75	10.52	9.97	10.31	15.10
DML 033/033s	5.0	4.7	5.3	5.1	5.4	5.0	5.0	4.7	5.0	4.6	4.5	4.2	4.6	4.2	12.85	9.86	9.57	14.46	13.84	14.67	21.40
DML 034s	5.0	4.7	5.3	5.1	5.4	5.0	5.0	4.7	5.0	4.6	4.5	4.2	4.6	4.2	24.71	20.12	19.57	28.60	27.65	30.13	43.78
DML 052/052s	7.9	7.5	8.5	8.1	8.6	8.0	8.0	7.4	7.9	7.3	7.2	6.6	7.3	6.7	7.67	5.62	5.45	8.45	8.02	8.32	12.18
DML 052.5s	7.9	7.5	8.5	8.1	8.6	8.0	8.0	7.4	7.9	7.3	7.2	6.6	7.3	6.7	9.58	7.01	6.80	10.54	10.01	10.38	15.19
DML 053/053s	7.9	7.5	8.5	8.1	8.6	8.0	8.0	7.4	7.9	7.3	7.2	6.6	7.3	6.7	12.87	9.81	9.52	14.44	13.80	14.58	21.28
DML 054s	7.9	7.5	8.5	8.1	8.6	8.0	8.0	7.4	7.9	7.3	7.2	6.6	7.3	6.7	25.70	20.77	20.19	29.64	28.62	31.07	45.17
DML 055s	7.9	7.5	8.5	8.1	8.6	8.0	8.0	7.4	7.9	7.3	7.2	6.6	7.3	6.7	36.22	29.07	28.25	41.63	40.15	43.45	63.19
DML 082/082s	12.6	11.9	13.6	12.9	13.8	12.8	12.8	11.8	12.7	11.7	11.5	10.6	11.7	10.8	7.68	5.44	5.27	8.32	7.85	8.02	11.77
DML 082.5s	12.6	11.9	13.6	12.9	13.8	12.8	12.8	11.8	12.7	11.7	11.5	10.6	11.7	10.8	10.53	7.84	7.61	11.69	11.13	11.63	17.01
DML 083/083s	12.6	11.9	13.6	12.9	13.8	12.8	12.8	11.8	12.7	11.7	11.5	10.6	11.7	10.8	14.19	10.98	10.66	16.03	15.37	16.35	23.85
DML 084/084s	12.6	11.9	13.6	12.9	13.8	12.8	12.8	11.8	12.7	11.7	11.5	10.6	11.7	10.8	28.61	21.33	20.68	31.76	30.24	31.63	46.24
DML 085/085s	12.6	11.9	13.6	12.9	13.8	12.8	12.8	11.8	12.7	11.7	11.5	10.6	11.7	10.8	43.81	35.32	34.33	50.47	48.71	52.83	76.81
DML 162/162s	27.7	26.2	29.8	28.3	30.4	28.0	28.1	26.0	27.8	25.7	25.3	23.3	25.6	23.6	7.68	5.43	5.26	8.31	7.85	8.01	11.75
DML 162.5s	27.7	26.2	29.8	28.3	30.4	28.0	28.1	26.0	27.8	25.7	25.3	23.3	25.6	23.6	10.57	7.36	7.12	11.36	10.69	10.83	15.91
DML 163/163s	27.7	26.2	29.8	28.3	30.4	28.0	28.1	26.0	27.8	25.7	25.3	23.3	25.6	23.6	16.33	11.18	10.82	17.41	16.33	16.43	24.16
DML 164/164s	27.7	26.2	29.8	28.3	30.4	28.0	28.1	26.0	27.8	25.7	25.3	23.3	25.6	23.6	32.19	23.54	22.81	35.40	33.60	34.83	50.99
DML 165/165s	27.7	26.2	29.8	28.3	30.4	28.0	28.1	26.0	27.8	25.7	25.3	23.3	25.6	23.6	44.64	36.59	35.59	51.82	50.16	54.83	79.63
DML 166/166s	27.7	26.2	29.8	28.3	30.4	28.0	28.1	26.0	27.8	25.7	25.3	23.3	25.6	23.6	45.53	37.37	36.35	52.89	51.20	56.01	81.33
DML 167s	27.7	26.2	29.8	28.3	30.4	28.0	28.1	26.0	27.8	25.7	25.3	23.3	25.6	23.6	43.92	40.14	39.19	53.50	52.78	60.97	87.77
DML 303/303s	57.7	54.6	62.0	58.8	63.1	58.3	58.5	54.0	57.8	53.4	52.6	48.5	53.3	49.2	15.70	10.56	10.20	16.59	15.52	15.48	22.79
DML 304/304s	57.7	54.6	62.0	58.8	63.1	58.3	58.5	54.0	57.8	53.4	52.6	48.5	53.3	49.2	32.51	25.00	24.26	36.63	35.06	37.19	54.26
DML 305/305s	57.7	54.6	62.0	58.8	63.1	58.3	58.5	54.0	57.8	53.4	52.6	48.5	53.3	49.2	45.71	36.96	35.93	52.72	50.91	55.29	80.38
DML 306/306s	57.7	54.6	62.0	58.8	63.1	58.3	58.5	54.0	57.8	53.4	52.6	48.5	53.3	49.2	43.73	39.89	38.95	53.22	52.49	60.57	87.22
DML 307s	57.7	54.6	62.0	58.8	63.1	58.3	58.5	54.0	57.8	53.4	52.6	48.5	53.3	49.2	64.25	53.95	52.51	75.40	73.29	81.06	117.51
DML 309s	57.7	54.6	62.0	58.8	63.1	58.3	58.5	54.0	57.8	53.4	52.6	48.5	53.3	49.2	83.62	69.78	67.90	97.86	95.02	104.77	114.45
DML 413	77.9	73.6	83.7	79.4	85.2	78.7	78.9	72.9	78.0	72.1	71.0	65.5	71.9	66.3	18.40	12.44	12.02	19.49	18.25	18.25	26.86
DML 414/414s	77.9	73.6	83.7	79.4	85.2	78.7	78.9	72.9	78.0	72.1	71.0	65.5	71.9	66.3	33.39	26.45	25.70	38.15	36.70	39.48	57.48
DML 415/415s	77.9	73.6	83.7	79.4	85.2	78.7	78.9	72.9	78.0	72.1	71.0	65.5	71.9	66.3	55.48	41.84	40.58	61.92	59.08	62.11	90.74
DML 417s	77.9	73.6	83.7	79.4	85.2	78.7	78.9	72.9	78.0	72.1	71.0	65.5	71.9	66.3	66.74	56.32	54.82	78.50	76.37	84.67	122.70
DML 419s	77.9	73.6	83.7	79.4	85.2	78.7	78.9	72.9	78.0	72.1	71.0	65.5	71.9	66.3	95.30	76.29	74.14	109.42	105.47	114.01	165.86
DML 604s	116.9	110.5	125.7	119.1	127.9	118.2	118.4	109.5	117.1	108.2	106.6	98.2	107.9	99.6	27.88	26.22	25.63	34.36	34.07	39.98	57.41
DML 607s	116.9	110.5	125.7	119.1	127.9	118.2	118.4	109.5	117.1	108.2	106.6	98.2	107.9	99.6	70.08	70.13	68.74	88.48	88.70	107.99	154.09
DML 609s	116.9	110.5	125.7	119.1	127.9	118.2	118.4	109.5	117.1	108.2	106.6	98.2	107.9	99.6	61.35	73.05	72.40	81.77	84.39	117.36	162.79
DML 757s	159.8	151.1	171.8	162.9	174.9	161.6	161.9	149.7	160.2	148.0	145.8	134.3	147.5	136.1	84.97	71.70	69.80	99.95	97.23	107.81	156.22
DML 759s	159.8	151.1	171.8	162.9	174.9	161.6	161.9	149.7	160.2	148.0	145.8	134.3	147.5	136.1	84.22	87.19	85.60	107.64	108.54	135.08	191.97

¹⁾ Drying capacity is based on following moisture content test standards before and after drying:

- R32: 990 – 50 ppm W
- R134a: 1050 – 50 ppm W
- R404A, R507: 1020 – 50 ppm W
- R407C: 1020 – 50 ppm W
- R410A: 1050 – 50 ppm W
- R22: 1050 – 60 ppm W

In accordance with ARI 710-2004

²⁾ Given in accordance with ARI 710-2004 for

- t_e = -15 °C
- t_c = 30 °C
- Δp = 0.07 bar

For technical data on other refrigerants, please contact your Danfoss Sales Representative

Technical data and capacities
(continued)

Drying and liquid capacity, type DCL

Type	Drying capacity [kg] refrigerant ¹⁾														Liquid capacity [kW] ²⁾						
	R134a		R404A		R507		R22		R407C		R410A		R32		R134a	R404A	R507	R22	R407C	R410A	R32
	[°C]																				
	24	52	24	52	24	52	24	52	24	52	24	52	24	52							
DCL 032/032s	3.9	3.6	4.2	3.9	4.2	3.9	3.9	3.6	3.9	3.6	3.5	3.2	3.6	3.3	6.70	5.01	4.86	7.45	7.09	7.43	10.86
DCL 032.5s	3.9	3.6	4.2	3.9	4.2	3.9	3.9	3.6	3.9	3.6	3.5	3.2	3.6	3.3	9.59	6.97	6.75	10.52	9.97	10.31	15.10
DCL 033/033s	3.9	3.6	4.2	3.9	4.2	3.9	3.9	3.6	3.9	3.6	3.5	3.2	3.6	3.3	12.85	9.86	9.57	14.46	13.84	14.67	21.40
DCL 052/052s	6.2	5.8	6.6	6.3	6.7	6.2	6.2	5.8	6.2	5.7	5.6	5.2	5.7	5.3	7.67	5.62	5.45	8.45	8.02	8.32	12.18
DCL 052.5s	6.2	5.8	6.6	6.3	6.7	6.2	6.2	5.8	6.2	5.7	5.6	5.2	5.7	5.3	9.58	7.01	6.80	10.54	10.01	10.38	15.19
DCL 053/053s	6.2	5.8	6.6	6.3	6.7	6.2	6.2	5.8	6.2	5.7	5.6	5.2	5.7	5.3	7.67	9.81	9.52	14.44	13.80	14.58	21.28
DCL 082/082s	9.8	9.3	10.6	10.0	10.8	10.0	10.0	9.2	9.9	9.1	9.0	8.3	9.1	8.4	7.68	5.44	5.27	8.32	7.85	8.02	11.77
DCL 082.5s	9.8	9.3	10.6	10.0	10.8	10.0	10.0	9.2	9.9	9.1	9.0	8.3	9.1	8.4	10.53	7.84	7.61	11.69	11.13	11.63	17.01
DCL 083/083s	9.8	9.3	10.6	10.0	10.8	10.0	10.0	9.2	9.9	9.1	9.0	8.3	9.1	8.4	14.19	10.98	10.66	16.03	15.37	16.35	23.85
DCL 084/084s	9.8	9.3	10.6	10.0	10.8	10.0	10.0	9.2	9.9	9.1	9.0	8.3	9.1	8.4	28.61	21.33	20.68	31.76	30.24	31.63	46.24
DCL 162/162s	21.6	20.5	23.3	22.1	23.7	21.9	21.9	20.3	21.7	20.0	19.7	18.2	20.0	18.4	7.68	5.43	5.26	8.31	7.85	8.01	11.75
DCL 162.5s	21.6	20.5	23.3	22.1	23.7	21.9	21.9	20.3	21.7	20.0	19.7	18.2	20.0	18.4	10.57	7.36	7.12	11.36	10.69	10.83	15.91
DCL 163/163s	21.6	20.5	23.3	22.1	23.7	21.9	21.9	20.3	21.7	20.0	19.7	18.2	20.0	18.4	16.33	11.18	10.82	17.41	16.33	16.43	24.16
DCL 164/164s	21.6	20.5	23.3	22.1	23.7	21.9	21.9	20.3	21.7	20.0	19.7	18.2	20.0	18.4	32.19	23.54	22.81	35.40	33.60	34.83	50.99
DCL 165/165s	21.6	20.5	23.3	22.1	23.7	21.9	21.9	20.3	21.7	20.0	19.7	18.2	20.0	18.4	44.64	36.59	35.59	51.82	50.16	54.83	79.63
DCL 166/166s	21.6	20.5	23.3	22.1	23.7	21.9	21.9	20.3	21.7	20.0	19.7	18.2	20.0	18.4	45.53	37.37	36.35	52.89	51.20	56.01	81.33
DCL 167s	21.6	20.5	23.3	22.1	23.7	21.9	21.9	20.3	21.7	20.0	19.7	18.2	20.0	18.4	43.92	40.14	39.19	53.50	52.78	60.97	87.77
DCL 303/303s	45.6	43.1	49	46.5	49.9	46.1	46.2	42.7	45.7	42.2	41.6	38.3	42.1	38.8	15.70	10.56	10.20	16.59	15.52	15.48	22.79
DCL 304/304s	45.6	43.1	49	46.5	49.9	46.1	46.2	42.7	45.7	42.2	41.6	38.3	42.1	38.8	32.51	25.00	24.26	36.63	35.06	37.19	54.26
DCL 305/305s	45.6	43.1	49	46.5	49.9	46.1	46.2	42.7	45.7	42.2	41.6	38.3	42.1	38.8	45.71	36.96	35.93	52.72	50.91	55.29	80.38
DCL 306/306s	45.6	43.1	49	46.5	49.9	46.1	46.2	42.7	45.7	42.2	41.6	38.3	42.1	38.8	43.73	39.89	38.95	53.22	52.49	60.57	87.22
DCL 307s	45.6	43.1	49	46.5	49.9	46.1	46.2	42.7	45.7	42.2	41.6	38.3	42.1	38.8	64.25	53.95	52.51	75.40	73.29	81.06	117.51
DCL 309s	45.6	43.1	49	46.5	49.9	46.1	46.2	42.7	45.7	42.2	41.6	38.3	42.1	38.8	83.62	69.78	67.90	97.86	95.02	104.77	114.45
DCL 413	63.3	59.8	68.1	64.5	69.3	64.0	64.1	59.3	63.4	58.6	57.7	53.2	58.4	53.9	18.40	12.44	12.02	19.49	18.25	18.25	26.86
DCL 414/414s	63.3	59.8	68.1	64.5	69.3	64.0	64.1	59.3	63.4	58.6	57.7	53.2	58.4	53.9	33.39	26.45	25.70	38.15	36.70	39.48	57.48
DCL 415/415s	63.3	59.8	68.1	64.5	69.3	64.0	64.1	59.3	63.4	58.6	57.7	53.2	58.4	53.9	55.48	41.84	40.58	61.92	59.08	62.11	90.74
DCL 417s	63.3	59.8	68.1	64.5	69.3	64.0	64.1	59.3	63.4	58.6	57.7	53.2	58.4	53.9	66.74	56.32	54.82	78.50	76.37	84.67	122.70
DCL 419s	63.3	59.8	68.1	64.5	69.3	64.0	64.1	59.3	63.4	58.6	57.7	53.2	58.4	53.9	95.30	76.29	74.14	109.42	105.47	114.01	165.86
DCL 604s	91.2	86.2	98.0	92.9	99.8	92.2	92.3	85.4	91.4	84.4	83.2	76.6	84.1	77.6	27.88	26.22	25.63	34.36	34.07	39.98	57.41
DCL 607s	91.2	86.2	98.0	92.9	99.8	92.2	92.3	85.4	91.4	84.4	83.2	76.6	84.1	77.6	70.08	70.13	68.74	88.48	88.70	107.99	154.09
DCL 609s	91.2	86.2	98.0	92.9	99.8	92.2	92.3	85.4	91.4	84.4	83.2	76.6	84.1	77.6	61.35	73.05	72.40	81.77	84.39	117.36	162.79
DCL 757s	126.6	119.7	136.1	129.0	138.5	128.0	128.3	118.6	126.9	117.2	115.5	106.4	116.9	107.8	84.97	71.70	69.80	99.95	97.23	107.81	156.22
DCL 759s	126.6	119.7	136.1	129.0	138.5	128.0	128.3	118.6	126.9	117.2	115.5	106.4	116.9	107.8	84.22	87.19	85.60	107.64	108.54	135.08	191.97

¹⁾ Drying capacity is based on following moisture content test standards before and after drying:

- R32: 990 – 50 ppm W
- R134a: 1050 – 50 ppm W
- R404A, R507: 1020 – 50 ppm W
- R407C: 1020 – 50 ppm W
- R410A: 1050 – 60 ppm W
- R22: 1050 – 60 ppm W

In accordance with ARI 710-2004

²⁾ Given in accordance with ARI 710-2004 for

- t_e = -15 °C
- t_c = 30 °C
- Δp = 0.07 bar

For technical data on other refrigerants, please contact your Danfoss Sales Representative

Conversions

$$\text{Drops of water} = \frac{(1 \text{ kg of refrigerant} \times (\text{Initial PPM of water} - \text{Final PPM of water}))}{50}$$

See ARI standard 710-86 for recommended initial and final PPM values for different refrigerants.

Ordering

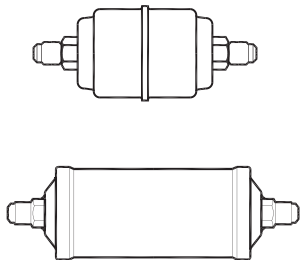

Type DCL Flare

Type	Connection size		Multi pack		Industrial pack for OEM only	
	[in.]	[mm]	Code no.	Qty.	Code no.	Qty.
DCL 032	1/4	6	023Z5000 ¹⁾	32	-	-
DCL 032	1/4	6	023Z5075	32	-	-
DCL 033	3/8	10	023Z5001 ¹⁾	32	-	-
DCL 033	3/8	10	023Z5089	32	-	-
DCL 052	1/4	6	023Z5002	24	023Z8002	16
DCL 053	3/8	10	023Z5003	24	023Z8003	16
DCL 082	1/4	6	023Z5004	24	023Z8004	16
DCL 083	3/8	10	023Z5005	24	023Z8005	16
DCL 084	1/2	12	023Z5006	24	-	-
DCL 162	1/4	6	023Z5007	12	023Z8007	12
DCL 163	3/8	10	023Z5008	12	023Z8008	12
DCL 164	1/2	12	023Z5009	12	023Z8009	12
DCL 165	5/8	16	023Z5010	12	023Z8010	12
DCL 166	3/4	19	023Z5011	12	-	-
DCL 303	3/8	10	023Z0012	8	-	-
DCL 304	1/2	12	023Z0013	8	023Z3013	8
DCL 305	5/8	16	023Z0014	8	023Z3014	8
DCL 306	3/4	19	023Z0156	8	-	-
DCL 414	1/2	12	023Z0102	8	-	-
DCL 415	5/8	16	023Z0103	8	-	-

¹⁾ Wire mesh in filter drier outlet

Ordering (continued)

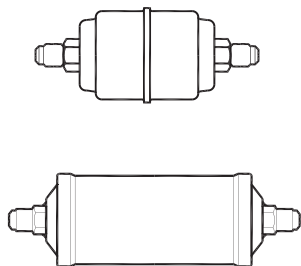

Type DML Flare

Type	Connection size		Multi pack		Industrial pack for OEM only	
	[in.]	[mm]	Code no.	Qty.	Code no.	Qty.
DML 032	1/4	6	023Z5035 ¹⁾	32	023Z8035 ¹⁾	28
DML 033	3/8	10	023Z5036 ¹⁾	32	023Z8036 ¹⁾	28
DML 033	3/8	10	023Z5090	32	-	-
DML 052	1/4	6	023Z5037	24	023Z8037	16
DML 053	3/8	10	023Z5038	24	023Z8038	16
DML 082	1/4	6	023Z5039	24	023Z8039	16
DML 083	3/8	10	023Z5040	24	023Z8040	16
DML 084	1/2	12	023Z5041	24	023Z8041	16
DML 085	5/8	16	023Z5073	24	-	-
DML 162	1/4	6	023Z5042	12	023Z8042	12
DML 163	3/8	10	023Z5043	12	023Z8043	12
DML 164	1/2	12	023Z5044	12	023Z8044	12
DML 165	5/8	16	023Z5045	12	023Z8045	12
DML 166	3/4	19	023Z5046	12	-	-
DML 303	3/8	10	023Z0049	8	023Z3049	8
DML 304	1/2	12	023Z0050	8	023Z3050	8
DML 305	5/8	16	023Z0051	8	023Z3051	8
DML 306	3/4	19	023Z0193	8	023Z3193	8
DML 385	5/8	16	023Z0189	8	-	-
DML 413	3/8	10	023Z0108	8	-	-
DML 414	1/2	12	023Z0109	8	-	-
DML 415	5/8	16	023Z0110	8	023Z3110	6
DML 416	3/4	19	023Z0195	8	023Z0210	6

¹⁾ Wire mesh in filter drier outlet

Ordering (continued)

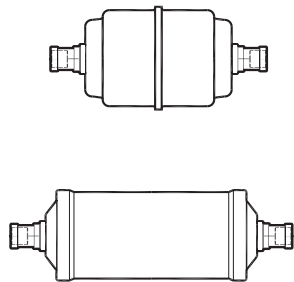

Type DCL Solder (cu-plated steel connectors)

Type	Conn. size	Multi pack		Industrial pack for OEM only		Conn. size	Multi pack		Industrial pack for OEM only	
	[in.]	Code no.	Qty.	Code no.	Qty.		[mm]	Code no.	Qty.	Code no.
DCL 032s	1/4	023Z4501	32	023Z4801	28	6	023Z4500	32	023Z4800	28
DCL 032.5s	5/16	023Z4502	32	023Z4803	28	8	-	-	-	-
DCL 033s	3/8	023Z4504	32	-	-	10	023Z4503	32	-	-
DCL 052s	1/4	023Z4506	24	023Z4805	16	6	023Z4505	24	023Z4804	16
DCL 052s	5/16	023Z4507	24	-	-	10	-	-	-	-
DCL 053s	3/8	023Z4509	24	023Z4807	16	10	023Z4508	24	-	-
DCL 082s	1/4	023Z4511	24	-	-	6	023Z4510	24	-	-
DCL 082s	5/16	023Z4512	28	-	-	6	-	-	-	-
DCL 083s	3/8	023Z4514	24	023Z4811	16	10	023Z4513	24	023Z4809	16
DCL 084s	1/2	023Z4516	24	023Z4813	16	12	023Z4515	24	-	-
DCL 162s	1/4	023Z4518	12	-	-	6	023Z4517	12	-	-
DCL 163s	3/8	023Z4521	12	-	-	10	023Z4519	12	023Z4814	12
DCL 164s	1/2	023Z4523	12	023Z4815	12	12	023Z4522	12	-	-
DCL 165s	5/8	023Z4524	12	023Z4816	12	12	-	-	-	-
DCL 166s	3/4	023Z4525	12	-	-	-	-	-	-	-
DCL 167s	7/8	023Z4526	12	-	-	-	-	-	-	-
DCL 303s	3/8	023Z4528	8	023Z4817	8	10	023Z4527	8	-	-
DCL 304s	1/2	023Z4530	8	-	-	12	023Z4529	8	-	-
DCL 305s	5/8	023Z4531	8	023Z4819	8	16	-	8	-	-
DCL 306s	3/4	023Z4533	8	-	-	18	023Z4532	8	-	-
DCL 307s	7/8	023Z4534	8	023Z4820	8	22	-	8	-	-
DCL 309s	1 1/8	023Z4536	8	-	-	28	023Z4535	8	-	-
DCL 414s	1/2	023Z4538	8	-	-	12	-	8	-	-
DCL 415s	5/8	023Z4539	8	-	-	16	-	8	-	-
DCL 417s	7/8	023Z4540	8	-	-	22	-	8	-	-
DCL 419s	1 1/8	023Z4542	8	-	-	28	023Z4541	8	-	-
DCL 604s	1/2	023Z4544	12	-	-	22	-	-	-	-
DCL 607s	7/8	023Z4545	6	-	-	22	-	-	-	-
DCL 609s	1 1/8	-	12	-	-	28	023Z4546	6	-	-
DCL 757s	7/8	023Z4548	12	-	-	22	-	-	-	-
DCL 759s	1 1/8	023Z4550	12	-	-	28	023Z4549	12	-	-

Ordering (continued)

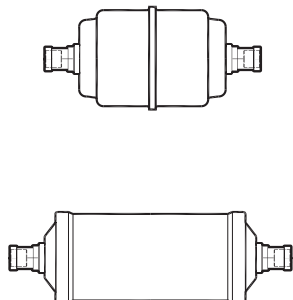

Type DML Solder (cu-plated steel connectors)

Type	Conn. size	Multi pack		Industrial pack for OEM only		Conn. size	Multi pack		Industrial pack for OEM only	
	[in.]	Code no.	Qty.	Code no.	Qty.		[mm]	Code no.	Qty.	Code no.
DML 032s	1/4	023Z4552	32	023Z4822	28	6	023Z4551	32	023Z4821	28
DML 032.5s	5/16	023Z4553	32	023Z4823	28	8	-	-	-	-
DML 033s	3/8	023Z4555	32	023Z4825	28	10	023Z4554	32	023Z4824	28
DML 034s	1/2	023Z4556	32	-	-	12	023Z4557	32	-	-
DML 052s	1/4	023Z4559	24	023Z4849	16	6	023Z4558	24	023Z4826	16
DML 052.5s	5/16	023Z4560	24	-	-	6	-	-	-	-
DML 053s	3/8	023Z4562	24	023Z4828	16	10	023Z4561	28	023Z4827	16
DML 054s	1/2	023Z4564	24	-	-	12	023Z4563	12	023Z4845	16
DML 055s	5/8	023Z4565	24	023Z4838	16	16	-	-	-	-
DML 082s	1/4	023Z4567	24	023Z4847	16	6	023Z4566	24	023Z4866	16
DML 082.5s	5/16	023Z4568	24	-	-	8	-	-	-	-
DML 083s	3/8	023Z4570	24	023Z4835	16	10	023Z4569	24	023Z4839	16
DML 084s	1/2	023Z4572	24	023Z4829	16	12	023Z4571	24	023Z4840	16
DML 085s	5/8	023Z4573	24	-	-	16	-	-	-	-
DML 162s	1/4	023Z4575	12	-	-	6	023Z4574	12	-	-
DML 163s	3/8	023Z4578	12	023Z4836	12	10	023Z4577	12	023Z4842	12
DML 164s	1/2	023Z4580	12	023Z4830	12	12	023Z4579	12	023Z4843	12
DML 165s	5/8	023Z4581	12	023Z4831	12	16	-	-	-	-
DML 166s	3/4	023Z4582	12	023Z4832	12	19	-	-	-	-
DML 167s	7/8	023Z4583	12	-	-	22	-	-	-	-
DML 303s	3/8	023Z4585	8	-	-	10	023Z4584	8	-	-
DML 304s	1/2	023Z4587	8	023Z4837	8	12	023Z4586	8	023Z4844	8
DML 305s	5/8	0023Z4588	8	023Z4833	8	16	-	-	-	-
DML 306s	3/4	023Z4589	8	023Z4848	8	19	-	-	-	-
DML 307s	7/8	023Z4590	8	023Z4834	8	22	-	-	-	-
DML 309s	1 1/8	023Z4592	8	-	-	28	023Z4591	8	-	-
DML 414s	1/2	023Z4594	8	-	-	12	023Z4593	8	-	-
DML 415s	5/8	023Z4595	8	-	-	16	-	-	-	-
DML 417s	7/8	023Z4596	8	023Z4896	6	22	-	-	-	-
DML 419s	1 1/8	023Z4598	8	023Z4898	6	28	023Z4597	8	-	-
DML 604s	1/2	023Z4600	12	-	-	12	023Z4599	12	-	-
DML 605s	1/2	-	-	-	-	18	023Z4601	6	-	-
DML 607s	7/8	023Z4602	6	023Z4902	-	22	-	-	-	-
DML 609s	1 1/8	023Z4604	12	-	-	28	023Z4603	12	-	-
DML 757s	7/8	023Z4605	12	023Z4905	4	22	-	-	-	-
DML 759s	1 1/8	023Z4607	12	023Z4907	4	28	023Z4606	12	-	-

Identification

Type codes

Type	Codes	Description
Filter drier	D	Drier
Solid core	C	80% Molecular Sieve / 20% activated alumina
	M	100% Molecular Sieve core
Application	L	Liquid line
Size (volume)	03	3 in. ³
	05	5 in. ³
	08	8 in. ³
	16	16 in. ³
	30	30 in. ³
	38	38 in. ³
	41	41 in. ³
	60	60 in. ³
	75	75 in. ³
Connection (filter connection in 1/8 of an inch increments)	2	1/4 in. / 6 mm
	2.5	5/16 in. / 8 mm
	3	3/8 in. / 10 mm
	4	1/2 in. / 12 mm
	5	5/8 in. / 16 mm
	6	3/4 in. / 18 (19) mm
	7	7/8 in. / 22 mm
	9	1 1/8 in. / 28 mm
Connection type	(blank)	Flare connection
	s	Solder connection

Example for type codes

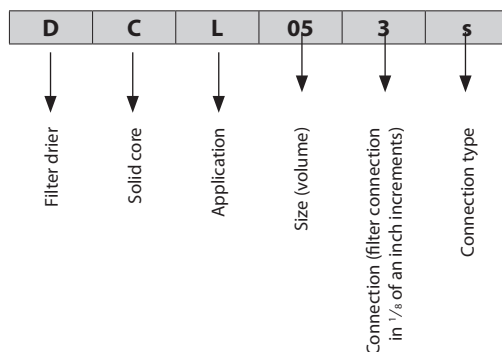

Selection

Type selection is made considering the application

Refrigerant and oil types		DCL	DML
Refrigerant	HFO	Recommended	Recommended
	HC ¹⁾	Recommended	Recommended
	HFC	Recommended	Recommended
	HCFC	Recommended	Recommended
Oil	Mineral or AB	Recommended	Recommended
	POE or PAG, pure	Recommended	Recommended
	POE or PAG, with additives	Not recommended ²⁾	Recommended

¹⁾ Only solder versions (cu-plated / pure copper) and connection sizes below 25 mm are approved for flammable refrigerants now.

²⁾ DCL Hermetic filter driers contain activated alumina, which is a polar material used for acid adsorption. Many oil additives are also polar substances and can be adsorbed by the activated alumina, rendering them useless, and reducing the drier's acid capacity, though this is not harmful to the system.

Selection example

Select the appropriate type (DML or DCL) based on refrigerant and oil type. Then select the drier size based on the adsorption and liquid capacity required.

c. Result

DML 163 or DML 163s can be used

If the initial moisture content is very small or a planned change of the filter drier is considered, a smaller filter drier size can be chosen.

a. Amount of charge: 25 kg R134a at tL= 24 °C
To dry 25 kg R134a at 24 °C from 1050 to 60 ppm moisture, a DML 16 is necessary

b. Cooling capacity: Qe= 20 kW
To obtain a mass flow corresponding to 20 kW cooling capacity with a DML 16 filter drier, a 3/8 inch connection must be chosen. Larger connections can be chosen in accordance with the liquid line dimension

Type	Drying capacity [kg] refrigerant ¹⁾														Liquid capacity [kW] ²⁾						
	R134a		R404A		R507		R22		R407C		R410A		R32		R134a	R404A	R507	R22	R407C	R410A	R32
	[°C]																				
	24	52	24	52	24	52	24	52	24	52	24	52	24	52	24	52					
DML 1.52s	2.9	2.7	3.1	3.0	3.2	2.9	2.9	2.7	2.9	2.7	2.6	2.4	2.7	2.5	5.97	4.21	3.86	6.32	5.97	5.97	8.78
DML 1.52x2/2s	2.9	2.7	3.1	3.0	3.2	2.9	2.9	2.7	2.9	2.7	2.6	2.4	2.7	2.5	5.97	4.21	3.86	6.32	5.97	5.97	8.78
DCL 033/033s	5.0	4.7	5.3	5.1	5.4	3.9	3.9	3.9	3.9	3.9	3.9	3.9	3.9	3.9	12.85	9.86	9.57	14.46	13.84	14.67	21.78
DML 163/163s	27.7	26.2	29.8	28.3	30.4	28.0	28.1	26.0	27.8	25.7	25.3	23.3	25.6	23.6	16.33	11.18	10.82	17.41	16.33	16.43	24.16
DML 164/164s	27.7	26.2	29.8	28.3	30.4	28.0	28.1	26.0	27.8	25.7	25.3	23.3	25.6	23.6	32.19	23.54	22.81	35.40	33.60	34.83	50.99
DML 165/165s	27.7	26.2	29.8	28.3	30.4	28.0	28.1	26.0	27.8	25.7	25.3	23.3	25.6	23.6	44.64	36.59	35.59	51.82	50.16	54.83	79.63
DML 166/166s	27.7	26.2	29.8	28.3	30.4	28.0	28.1	26.0	27.8	25.7	25.3	23.3	25.6	23.6	45.53	37.37	36.35	52.89	51.20	56.01	81.33
DML 167s	27.7	26.2	29.8	28.3	30.4	28.0	28.1	26.0	27.8	25.7	25.3	23.3	25.6	23.6	43.92	40.14	39.19	53.50	52.78	60.97	87.77
DML 303/303s	12.7	12.2	13.5	13.0	14.0	12.5	12.5	12.5	12.5	12.5	12.5	12.5	12.5	12.5	15.70	10.56	10.27	15.48	14.88	15.48	22.79



Design / Function

DML / DCL 03

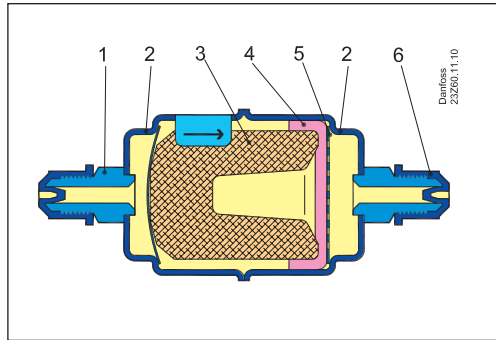

DML / DCL 05

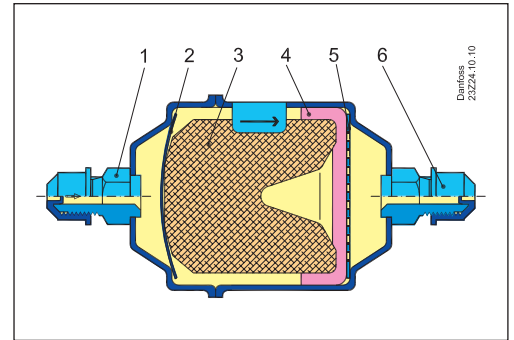

DML / DCL 08, DML / DCL 16

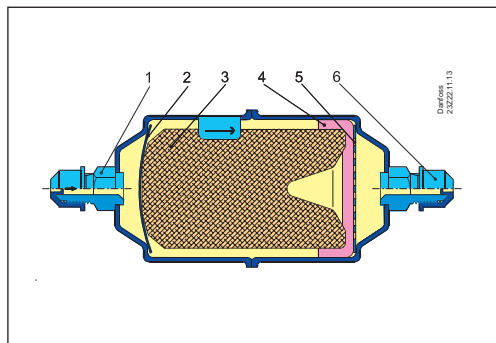

DML / DCL 30, DML / DCL 41

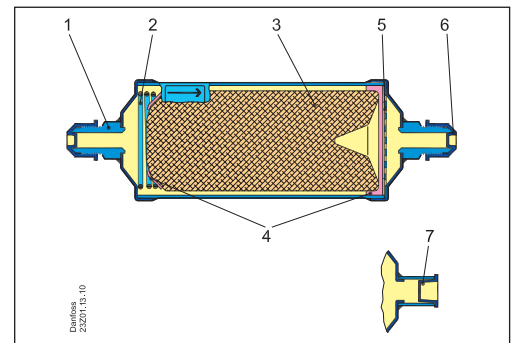

DML / DCL 60, DML / DCL 75

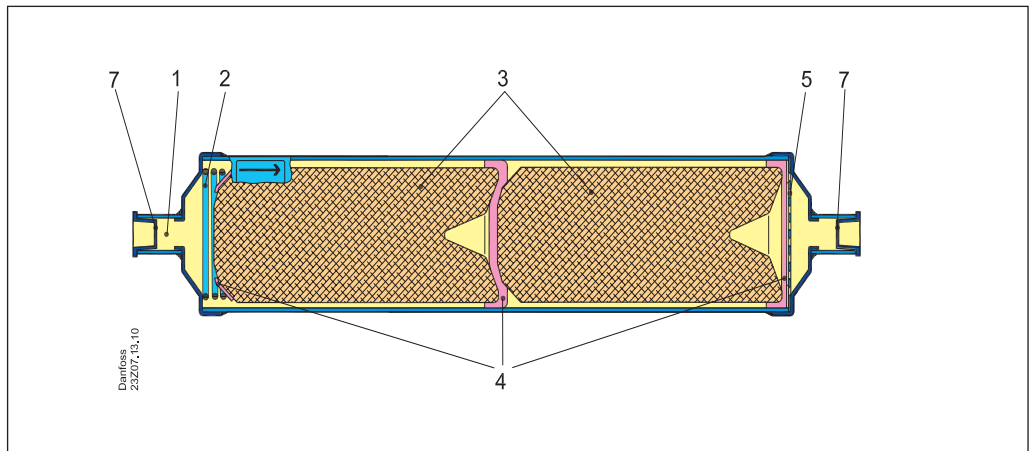

1. Inlet
2. Spring
3. Solid core
4. Polyester mat
5. Perforated plate
6. Seal cap, flare connection
7. Seal cap, solder connection

The relatively large diameter of the hermetic filter drier means that the liquid flow velocity is suitably low and the pressure drop minimal.

Powder formation is eliminated because the solid core grains are bonded and cannot move against each other.

Dimensions and weights

Flare connections

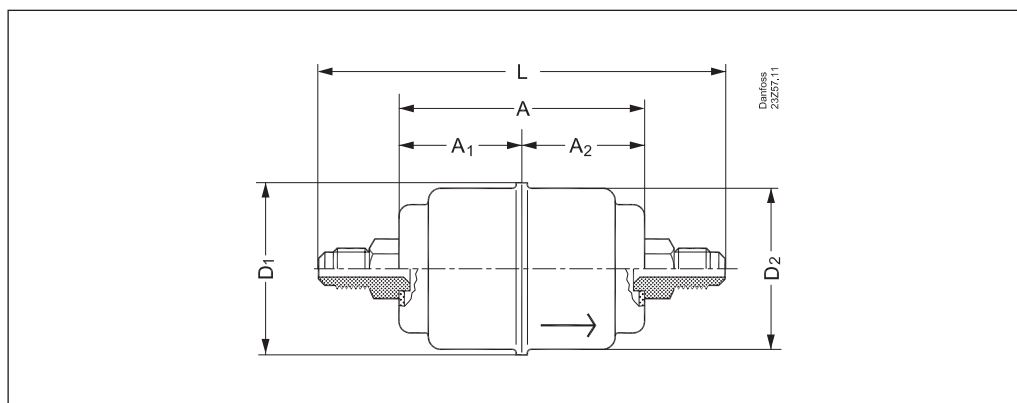

Type	A	A ₁	A ₂	L	D ₁	D ₂	Net weight
	[mm]	[mm]	[mm]	[mm]	[mm]	[mm]	[Kg]
DCL / DML 032	66	33	33	110	46	43	0.20
DCL / DML 033	66	33	33	123	46	43	0.23

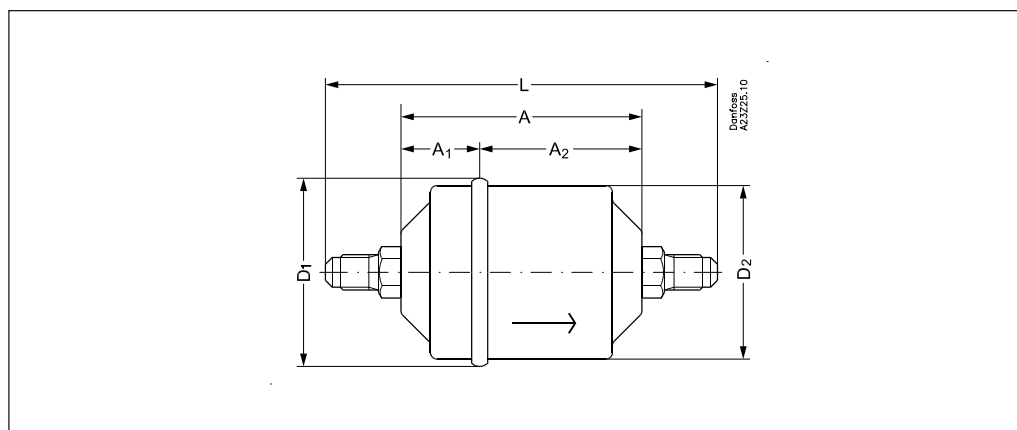

Type	A	A ₁	A ₂	L	D ₁	D ₂	Net weight
	[mm]	[mm]	[mm]	[mm]	[mm]	[mm]	[Kg]
DCL / DML 052	75	24.5	50.5	119	58	54	0.39
DCL / DML 053	75	24.5	50.5	132	58	54	0.42

Dimensions and weights
(continued)

Flare connections

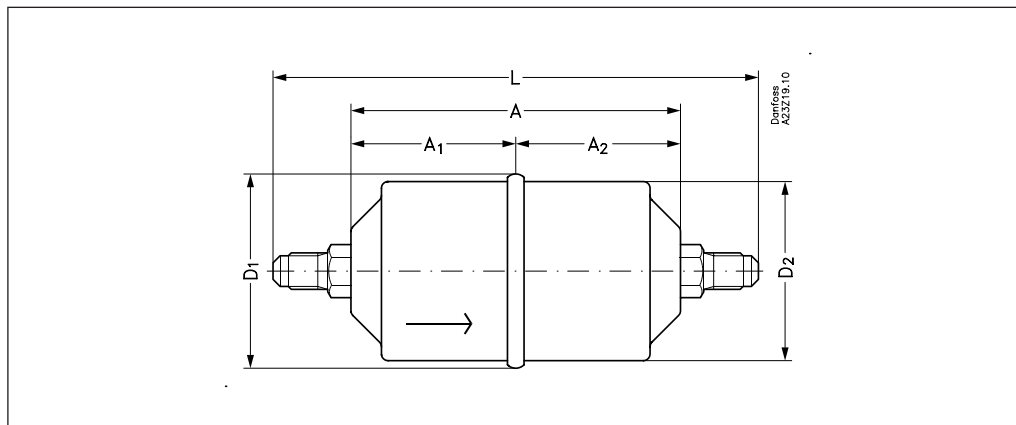

Type	A [mm]	A ₁ [mm]	A ₂ [mm]	L [mm]	D ₁ [mm]	D ₂ [mm]	Net weight [Kg]
DCL / DML 082	101	50.5	50.5	145	58	54	0.40
DCL / DML 083	101	50.5	50.5	158	58	54	0.44
DCL / DML 084	101	50.5	50.5	166	58	54	0.48
DCL / DML 085	101	50.5	50.5	175	58	54	0.52
DCL / DML 162	110	55.0	55.0	154	80	76	0.79
DCL / DML 163	110	55.0	55.0	167	80	76	0.82
DCL / DML 164	110	55.0	55.0	175	80	76	0.87
DCL / DML 165	110	55.0	55.0	184	80	76	0.91
DCL / DML 166	110	55.0	55.0	182	80	76	0.99

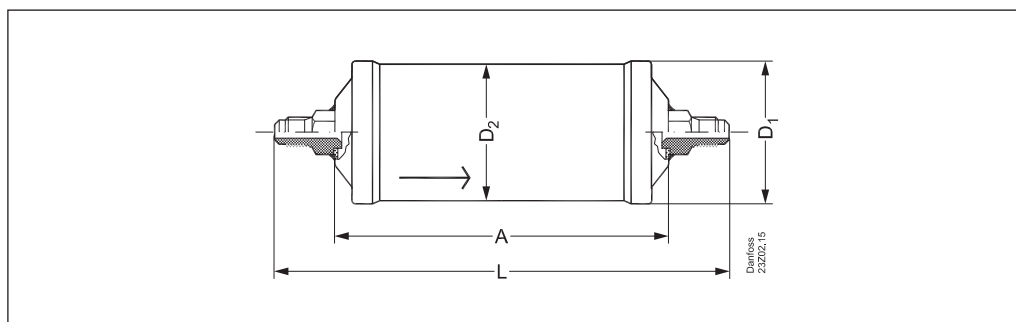

Type	A [mm]	L [mm]	D ₁ [mm]	D ₂ [mm]	Net weight [Kg]
DCL / DML 303	186	243	80	76	1.33
DCL / DML 304	186	251	80	76	1.38
DCL / DML 305	186	260	80	76	1.42
DCL / DML 306	186	258	80	76	1.49
DML 385	151	225	93	89	1.59
DCL / DML 413	187	244	93	89	1.86
DCL / DML 414	187	252	93	89	1.91
DCL / DML 415	187	261	93	89	1.95

Dimensions and weights
(continued)

Solder connection (cu-plated steel connectors)

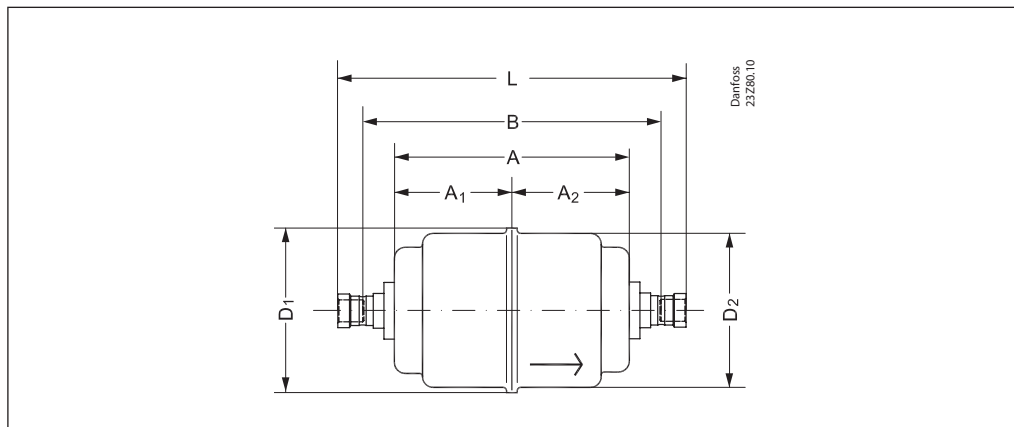

Type	A	A ₁	A ₂	B	L	D ₁	D ₂	Net weight [Kg]
	[mm]	[mm]	[mm]	[mm]	[mm]	[mm]	[mm]	
DCL / DML 032s	66	33	33	84	98	46	43	0.20
DCL / DML 032.5s	66	33	33	85	101	46	43	0.20
DCL / DML 033s	66	33	33	86	104	46	43	0.20
DCL / DML 034s	66	33	33	84	108	46	43	0.21

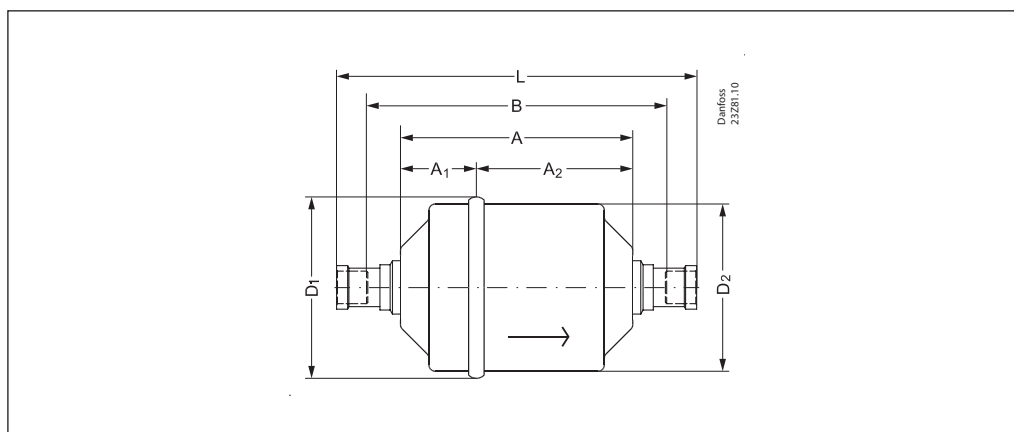

Type	A	A ₁	A ₂	B	L	D ₁	D ₂	Net weight [Kg]
	[mm]	[mm]	[mm]	[mm]	[mm]	[mm]	[mm]	
DCL / DML 052s	75	24.5	50.5	93	107	58	54	0.39
DCL / DML 052.5s	75	24.5	50.5	94	110	58	54	0.39
DCL / DML 053s	75	24.5	50.5	95	113	58	54	0.39
DCL / DML 054s	75	24.5	50.5	97	117	58	54	0.40
DCL / DML 055s	75	24.5	50.5	101	125	58	54	0.41

Dimensions and weights
(continued)

Solder connection (cu-plated steel connectors)

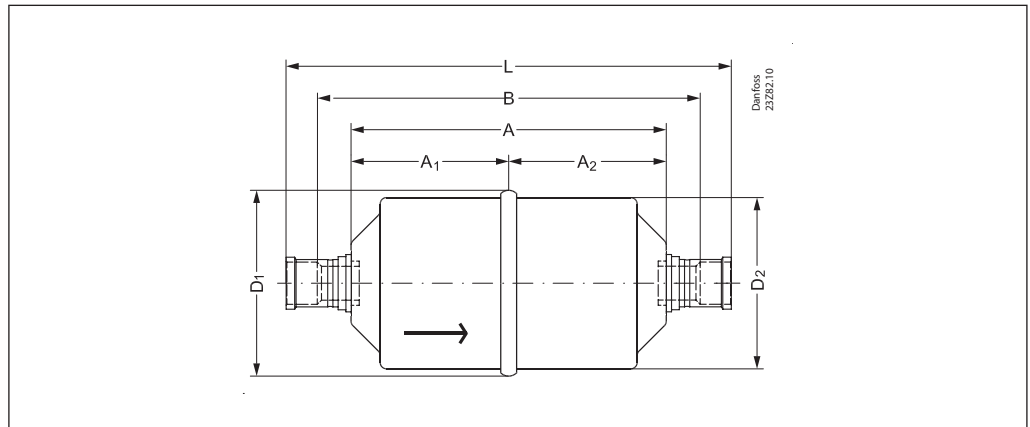

Type	A	A ₁	A ₂	B	L	D ₁	D ₂	Net weight
	[mm]	[mm]	[mm]	[mm]	[mm]	[mm]	[mm]	[Kg]
DCL / DML 082s	101	50.5	50.5	119	133	58	54	0.40
DCL / DML 082.5s	101	50.5	50.5	120	136	58	54	0.40
DCL / DML 083s	101	50.5	50.5	121	139	58	54	0.40
DCL / DML 084s	101	50.5	50.5	123	143	58	54	0.41
DCL / DML 085s	101	50.5	50.5	127	151	58	54	0.42
DCL / DML 162s	110	55.0	55.0	128	142	80	76	0.79
DCL / DML 162.5s	110	55.0	55.0	129	145	80	76	0.79
DCL / DML 163s	110	55.0	55.0	130	148	80	76	0.79
DCL / DML 164s	110	55.0	55.0	132	152	80	76	0.81
DCL / DML 165s	110	55.0	55.0	136	160	80	76	0.82
DCL / DML 166s	110	55.0	55.0	136	164	80	76	0.84
DCL / DML 167s	110	55.0	55.0	136	170	80	76	0.85

**Dimensions and weights
(continued)**

Solder connection (cu-plated steel connectors)

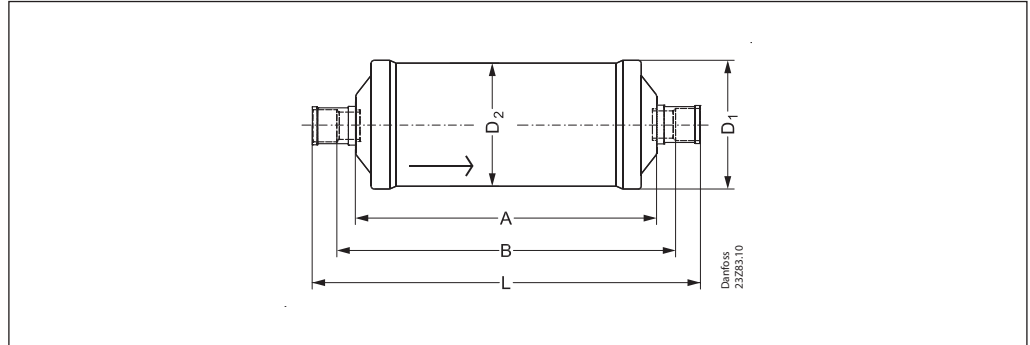

Type	A	B	L	D ₁	D ₂	Net weight [Kg]
	[mm]	[mm]	[mm]	[mm]	[mm]	
DCL / DML 303s	186	206	224	80	76	1.30
DCL / DML 304s	186	208	228	80	76	1.31
DCL / DML 305s	186	212	236	80	76	1.32
DCL / DML 306s	186	212	240	80	76	1.34
DCL / DML 307s	186	212	246	80	76	1.35
DCL / DML 309s	186	196	250	80	76	1.37
DCL / DML 414s	187	209	229	93	89	1.84
DCL / DML 415s	187	213	237	93	89	1.85
DCL / DML 417s	187	213	247	93	89	1.88
DCL / DML 419s	187	197	251	93	89	1.90
DCL / DML 604s	337	359	379	80	76	2.35
DCL / DML 606s	337	363	391	80	76	2.39
DCL / DML 607s	337	363	397	80	76	2.40
DCL / DML 609s	337	347	401	80	76	2.41
DCL / DML 757s	338	364	398	93	89	3.38
DCL / DML 759s	338	348	402	93	89	3.40

Danfoss can accept no responsibility for possible errors in catalogues, brochures and other printed material. Danfoss reserves the right to alter its products without notice. This also applies to products already on order provided that such alterations can be made without subsequential changes being necessary in specifications already agreed. All trademarks in this material are property of the respective companies. Danfoss and the Danfoss logotype are trademarks of Danfoss A/S. All rights reserved.