



Chemical Feeders

»»» Automatic Chlorinators
and Brominators

FAMCO

هایپر صنعت

EASY, ECONOMICAL
SANITIZATION FOR ANY POOL



www.famcocorp.com
E-mail: info@famcocorp.com
[@famco_group](https://www.instagram.com/famco_group)

Tel: ۰۲۱-۴۸۰۰۰۰۴۹
Fax: ۰۲۱-۴۴۹۹۴۶۴۲

تهران، کیلومتر ۲۱ بزرگراه لشگری (جاده مخصوص کرج)
روبروی پالایشگاه نفت پارس، پلاک ۱۲

- » Available for chlorine or bromine sanitization using large or small slow-dissolving tablets
- » 9- and 4.2-lb chemical capacities fit in-ground and above-ground pools and spas of all sizes
- » Multiple in-line and off-line configurations allow for simple installation in new construction, aftermarket and replacement applications
- » Large dial control valve allows for easy feed rate adjustment
- » EasyLok™ threaded cover provides safe and convenient access to tablets
- » Chemical-resistant Viton® seal and corrosion-resistant components provide heavy-duty durability

PERFORMANCE DATA

MODEL NUMBER	PIPE SIZE	CHEMICAL CAPACITY	FEEDER WIDTH	FEEDER HEIGHT
IN-LINE CHLORINATORS				
CL100	1½" FIP	4.2 lbs.	8¼"	15¼"
CL200*	1½" FIP	9 lbs.	9"	14¾"
CL200S**	2" SKT	9 lbs.	9"	14¾"
OFF-LINE CHLORINATORS				
CL110	—	4.2 lbs.	6¾"	13"
CL220	—	9 lbs.	8¼"	15½"
OFF-LINE CHLORINATORS FOR ABOVE-GROUND POOLS***				
CL110ABG	—	4.2 lbs.	6¾"	13"
CL220ABG	—	9 lbs.	8¼"	15½"
OFF-LINE BROMINATORS				
CL220BR	—	9 lbs.	8¼"	15½"
ACCESSORIES				
SP1500UNMPAK1	Flush union connector with 1½" male nipple. For mounting in-line chlorine feeders.			
SP1500UNPAK2	Set of two flush union connectors. Fits CL100 and CL200 chlorinators inlet and outlet.			

IN-LINE AND OFF-LINE CONFIGURATIONS

To accommodate most capacity, plumbing and space considerations

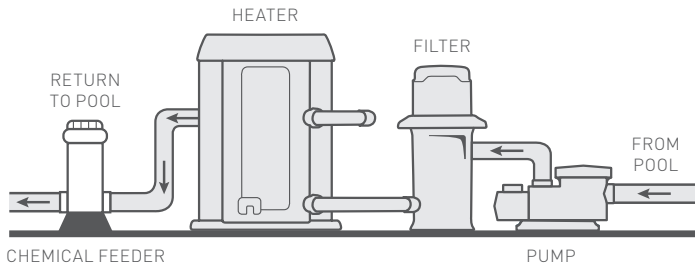

SP1500UNPAK2



IN-LINE INSTALLATION FOR CL100, CL200 AND CL200S IN-LINE FEEDERS

Use 1-1/2" FIP ports to connect to filter system plumbing

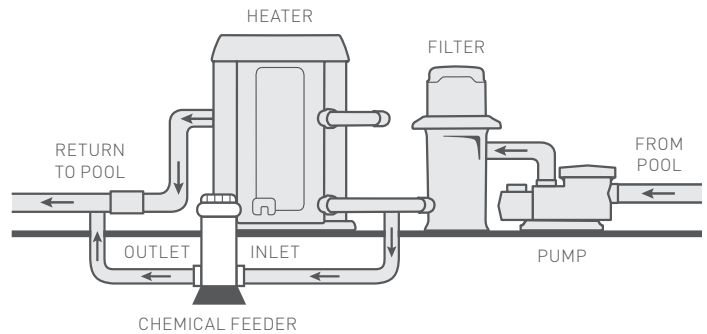

UNIVERSAL ADAPTER
KIT (ABOVE GROUND)

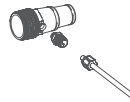

SADDLE CLAMP
ASSEMBLY

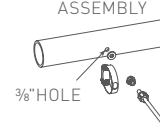

OFF-LINE INSTALLATION FOR CL110 AND CL220 OFF-LINE FEEDERS

Install next to filtration equipment and operate on system pressure differential

*Includes mounting base.

**Features 2" inlet and outlet ports for applications with 50 GPM to 90 GPM flow rates.

***Packaged with a universal adapter kit for all Hayward above-ground filter systems—Perflex®, sand or cartridge.