

## Split Case Double Suction Centrifugal Pump

# SPLT & SPLT.M SERIES (50 Hz)

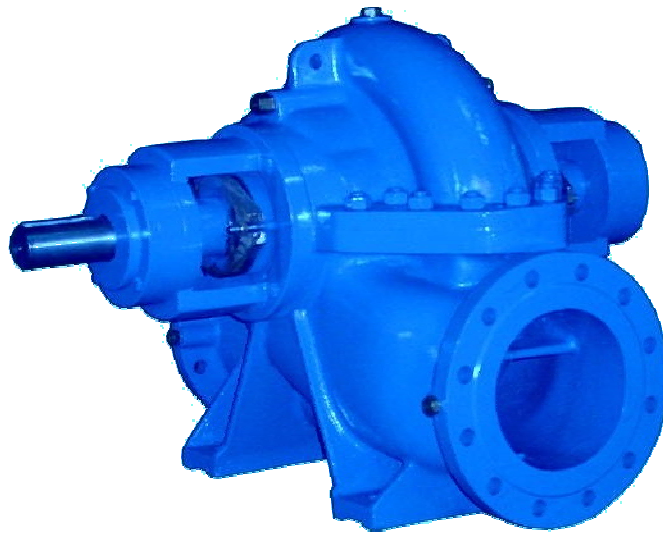

## TECHNICAL MANUAL



Eylül/2015

## SPLT & SPLT.M Series

Split Case Double Suction Centrifugal Pump

### General Information



**Mas Grup**

### Fields of Application

- Water supply and booster stations.
- Irrigation, overhead irrigation.
- Drainage stations.
- Power stations.
- Industrial water supply systems.
- Firefighting systems.
- Marine applications.
- General applications in refineries.

### Pumped Liquids

Thin, clean, non-aggressive and non-explosive liquids free from large solid particles or fibers.

For special applications, please consult to MAS DAF MAKINA SAN. A.Ş.

### Design

- Single-stage axially split casing pumps with double entry and radial impeller.
- Double entry, closed impeller is hydraulically thrust compensated.
- Lower casing is in-line design, suction and discharge nozzles are on the same line.
- Upper casing is self-aligning and it is easy to mount.
- The NPSH values are reduced and high suction lifts are possible thanks to double suction impeller.
- Two different designs can be applicable:

1. Long shaft design: For soft packing stuffing box, the length of the pump shaft is longer. It is also possible to use mechanical seal on this design.

2. Short shaft design: For mechanical seal applications, shaft length can be reduced. Therefore, compact and rigid pumps are available.

- Pump and motor are separate components connected to each other via flexible coupling and mounting on a base plate. It is also possible to couple the pump to the diesel engine.

### Bearings

For pump groups A, B and C, there are ball bearings at the both dead and drive end of the pump. For pump groups D, E and F, a cylindrical roller bearing is installed at the drive end of the pump and there is a ball bearing at the dead end of the pump.

### Shaft Seal

- Uncooled soft packed stuffing box with lantern ring is essential for the long shaft design.
- There is a leakage setting device on the washing water line of packing.
- Different types of mechanical seals are available on the long or short shaft design pumps.

### Technical Data

- Suction Nozzle : DN 80... DN 250
- Discharge Nozzle : DN 65...DN 200
- Operating Pressure : 16 - 20 Bar
- Speed Range : 960 – 3500 rpm
- Capacity Range : 30 – 1800 m<sup>3</sup> / h
- Head Range : 15 - 160 m

### Identification Code

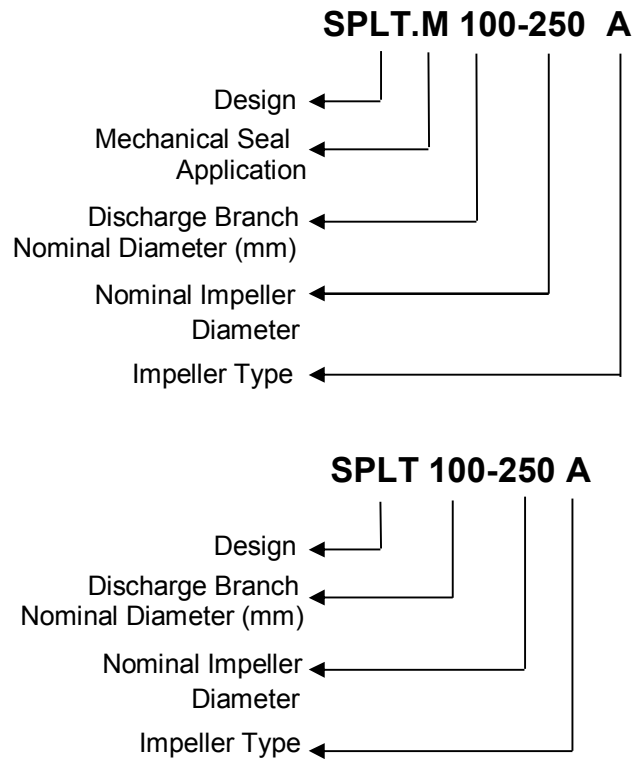

**SPLT & SPLT.M Series**  
Split Case Double Suction Centrifugal Pump  
Interchangeability for Pumps



**Mas Grup**

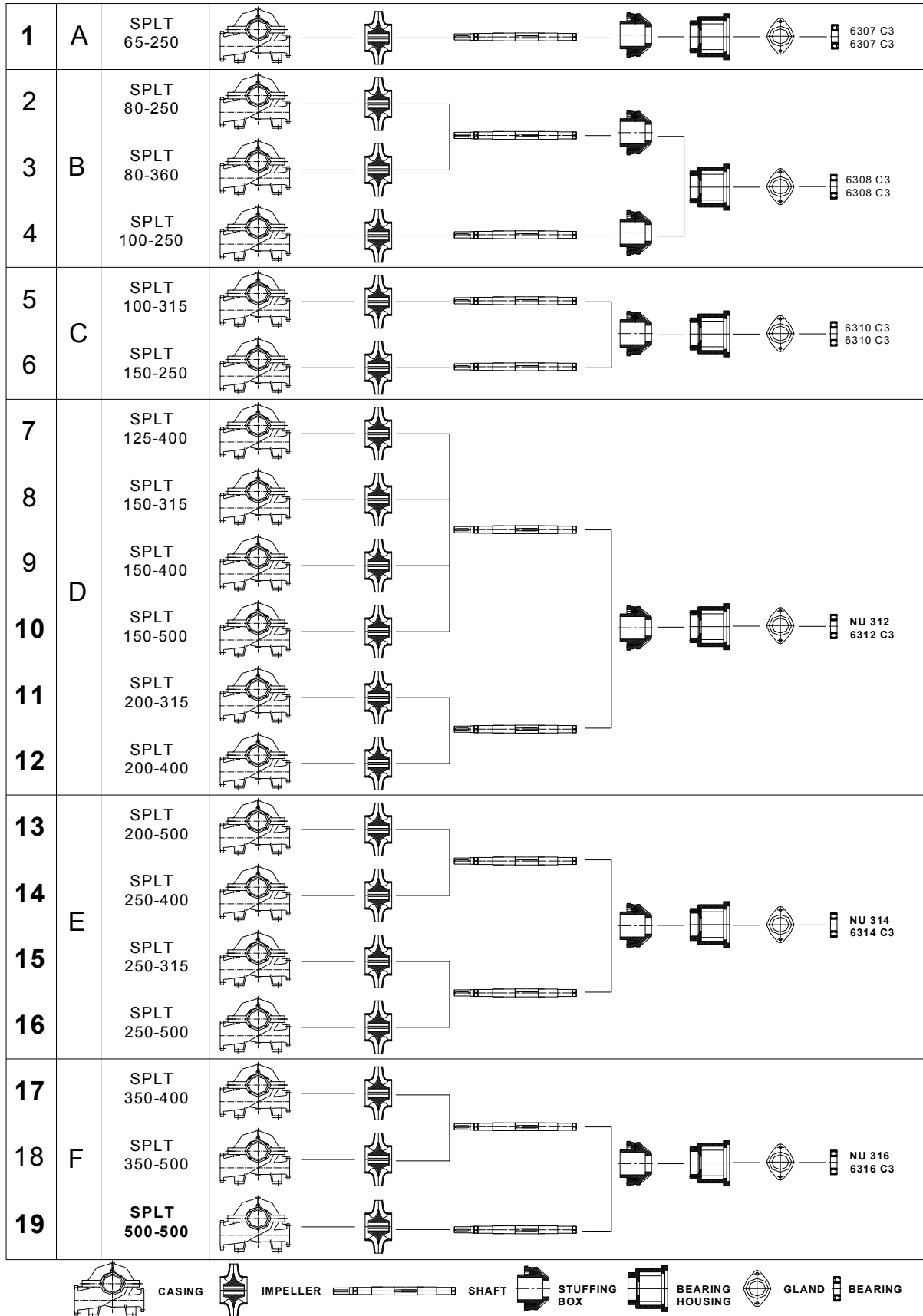

**SPLT & SPLT.M Series**  
Split Case Double Suction Centrifugal Pump  
Technical Advantages

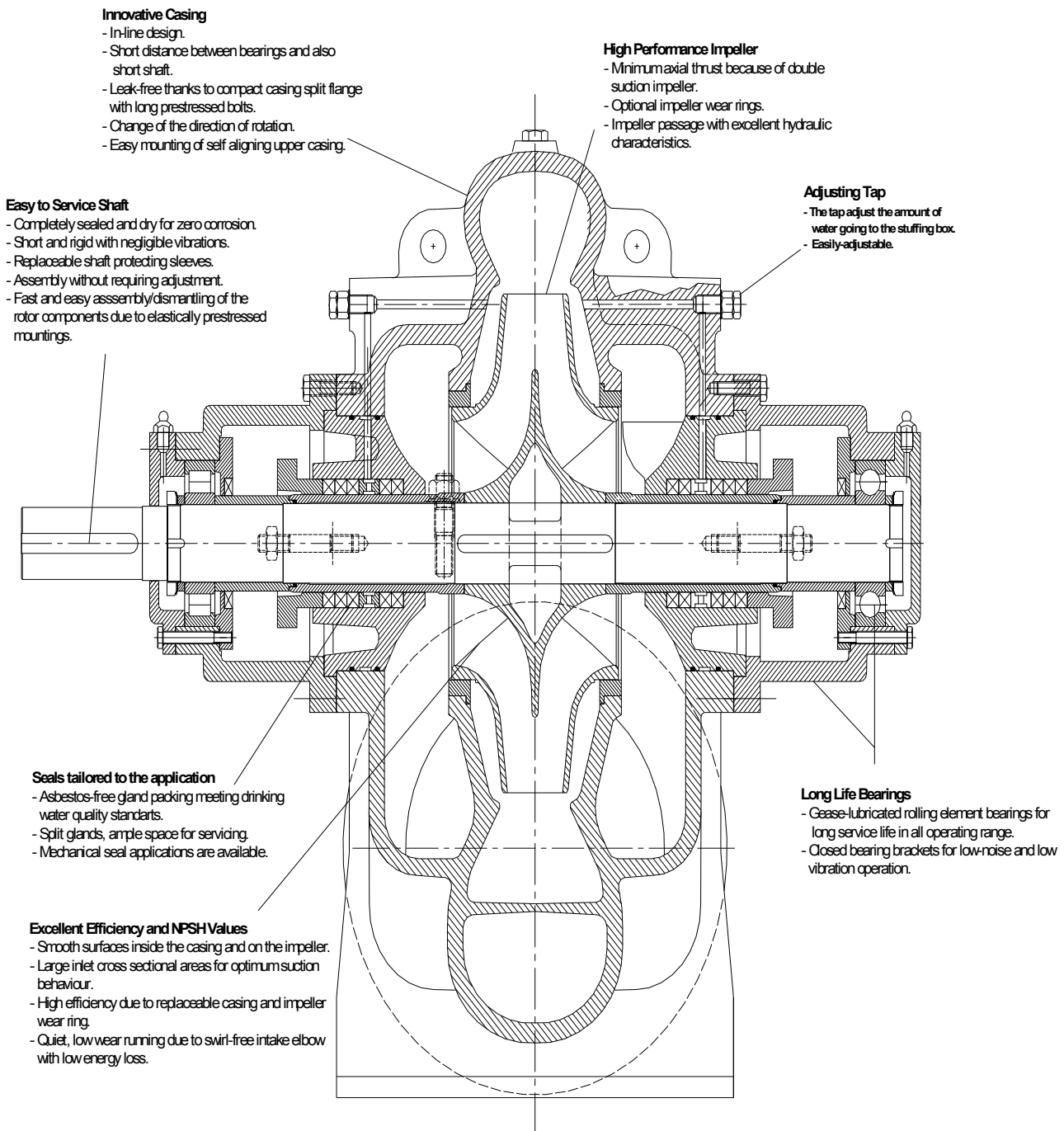

**SPLT & SPLT.M Series**  
Split Case Double Suction Centrifugal Pump  
**ATEX Description**



**Mas Grup**

**ATEX Codification**

ATEX -95

$\text{Ex}$  II 2G /D c Tx (85 °C – 200 °C)

Equipment Groups (Annex I of Directive 94/9/EC)							
Group I (mines, mine gas and dust)		Group II (other explosive atmospheres gas/dust)					
Category M 1	Category M 2	Category 1		Category 2		Category 3	
		G (gas) (Zone 0)	D (dust) (Zone 20)	G (gas) (Zone 1)	D (dust) (Zone 21)	G (gas) (Zone 2)	D (dust) (Zone 22)
For equipment providing a very high level of protection when endangered by an explosive atmosphere	For equipment providing a high level of protection when likely to be endangered by an explosive atmosphere	For equipment providing a very high level of protection when used in areas where an explosive atmosphere is very likely to occur		For equipment providing a high level of protection when used in areas where an explosive atmosphere is likely to occur		For equipment providing a normal level of protection when used in areas where an explosive atmosphere is less likely to occur	

TEMPERATURE CLASS		
Temperature class required by the area classification	Ignition temperature of gas or vapor	Allowable temperature classes of equipment
T1	> 450 °C	T1 - T6
T2	> 300 °C	T2 - T6
T3	> 200 °C	T3 - T6
T4	> 135 °C	T4 - T6
T5	> 100 °C	T5 - T6
T6	> 85 °C	T6

Code	Description
II	The Usage in other non-mining explosive atmospheres
2	2. Category: High level of protection
G	For potentially explosive environments due to gases or vapors
T	Temperature class
X	ATEX Marking of the motor manufacturer

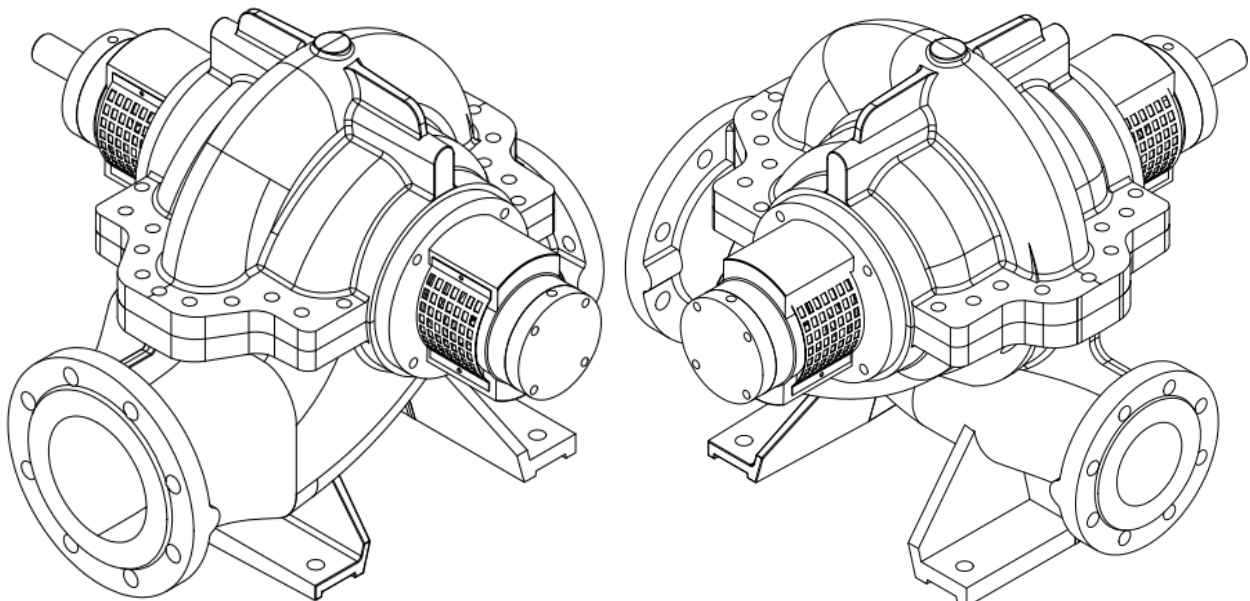

**SPLT & SPLT.M Series**  
Split Case Double Suction Centrifugal Pump  
Cross-Sectional Drawing For SPLT

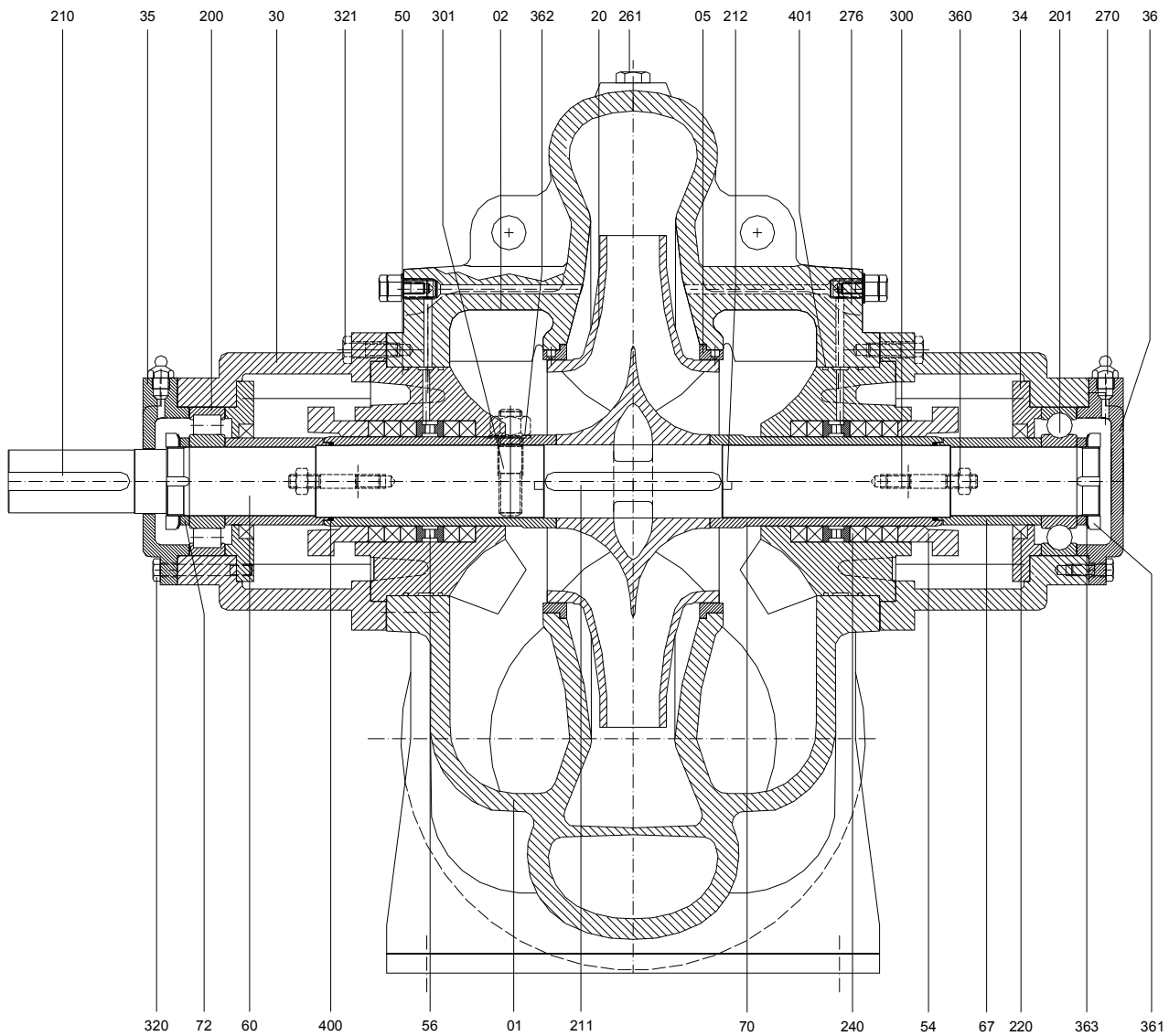

**PART LIST**

PART NO	PART NAME	PART NO	PART NAME
01	Casing Lower Part	211	Key for Impeller
02	Casing Upper Part	212	Key for Wearing Ring
05	Wear Ring	220	Oil Seal
20	Impeller	240	Soft Packing
30	Bearing Housing	261	Plug
34	Bearing Cover (Dead Side)	270	Greaser
35	Bearing Cover (Motor Side)	276	Adjusting Tap
36	Bearing Housing Cover	300	Stud for Gland
50	Stuffing Box	301	Casing Stud
54	Gland	320	Hexagonal Bolt
56	Lantern Ring	321	Bolt
60	Pump Shaft	360	Nut for Gland
67	Space Sleeve	361	Nut for Bearing
70	Bushing for Seal	362	Nut for Casing Stud
72	Bushing for Bearing	363	Washer for Bearing
200	Roller Bearing	400	O-Ring (Shaft Sleeve)
201	Ball Bearing	401	O-Ring (Stuffing Box)
210	Key for Coupling		

**SPLT & SPLT.M Series**  
Split Case Double Suction Centrifugal Pump  
Cross-Sectional Drawing For SPLT.M

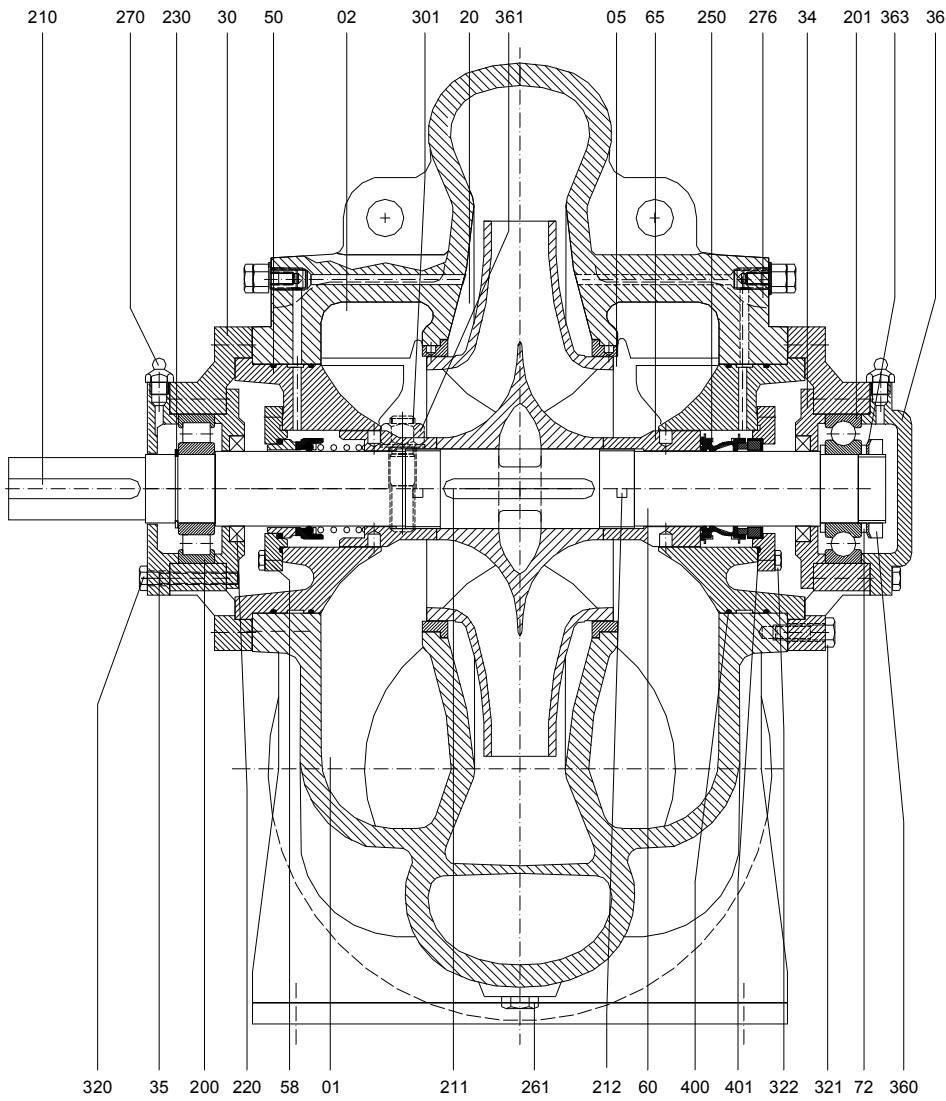

**PART LIST**

PART NO	PART NAME	PART NO	PART NAME
01	Casing Lower Part	212	Key for Wearing Ring
02	Casing Upper Part	220	Oil Seal
05	Wear Ring	230	Safety Ring
20	Impeller	250	Mechanical Seal
30	Bearing Housing	261	Plug
34	Bearing Cover (Dead Side)	270	Greaser
35	Bearing Cover (Motor Side)	276	Adjusting Tap
36	Bearing Housing Cover	301	Casing Stud
50	Stuffing Box	320	Hexagonal Bolt
58	Mech. Seal Cover	321	Bolt
60	Pump Shaft	322	Bolt for Mech. Seal Cover
65	Impeller Nut	361	Nut for Casing Stud
72	Bushing for Bearing	362	Nut for Casing Stud
200	Roller Bearing	363	Washer for Bearing
201	Ball Bearing	400	O-Ring (Shaft Sleeve)
210	Key for Coupling	401	O-Ring (Stuffing Box)
211	Key for Impeller		

**SPLT & SPLT.M Series**

Split Case Double Suction Centrifugal Pump

**Technical Data**



**Mas Grup**

**Bearings, Stuffing-Box for SPLT (Soft Packing Design)**

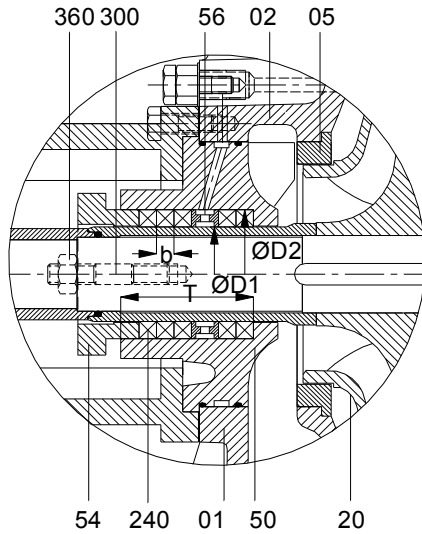

01	Casing Lower Part
02	Casing Upper Part
05	Wearing Ring
20	Impeller
50	Stuffing Box
54	Gland
56	Lantern Ring
240	Soft Packing
300	Stud for Gland
360	Nut for Gland

Pump Type	Bearing (Motor Side)	Bearing (Dead Side)	Soft Packing (ØD1xØD2xbxT) (mm)	Sealing
SPLT 65-250	6307 C3	6307 C3	Ø61xØ45x8x55.5	2x(4 Soft Packing +1 Lantern Ring)
SPLT 80-250 SPLT 80-360 SPLT 100-250	6308 C3	6308 C3	Ø75X Ø55x10x76	2x(5 Soft Packing +1 Lantern Ring)
SPLT 100-315 SPLT 150-250	6310 C3	6310 C3	Ø90XØ66x12x75	2x(4 Soft Packing +1 Lantern Ring)
SPLT 125-400 SPLT 150-315 SPLT 150-400 SPLT 150-500 SPLT 200-315 SPLT 200-400	NU 312	6312 C3	Ø106XØ78x14x105	2x(5 Soft Packing +1 Lantern Ring)
SPLT 200-500 SPLT 250-400 SPLT 250-315 SPLT 250-500	NU 314	6314 C3	Ø116XØ88x14x105	2x(5 Soft Packing +1 Lantern Ring)
SPLT 350-400 SPLT 350-500 SPLT 500-500	NU 316	6316 C3	Ø140XØ100x20x140.5	2x(5 Soft Packing+1 Lantern Ring)

**Bearings, Stuffing-Box for SPLT.M (Compact Design with Mechanical Seal)**

Pump Type	Bearing (Motor Side)	Bearing (Dead Side)	Mech. Seal Diameter (mm)	Sealing
SPLT.M 65-250	6306 C3	6306 C3	Ø35	M3N or MG1
SPLT.M 80-250 SPLT.M 80-360 SPLT.M 100-250	6307 C3	6307 C3	Ø40	M3N or MG1
SPLT.M 100-315 SPLT.M 150-250	6309 C3	6309 C3	Ø50	M3N or MG1
SPLT.M 125-400 SPLT.M 150-315 SPLT.M 150-400 SPLT.M 150-500 SPLT.M 200-315 SPLT.M 200-400	NU 311	6311 C3	Ø60	M3N or MG1
SPLT.M 200-500 SPLT.M 250-400 SPLT.M 250-315 SPLT.M 250-500	NU 313	6313 C3	Ø70	M3N or MG1
SPLT.M 350-400	NU 315	6315 C3	Ø80	M3N or MG1



**SPLT & SPLT.M Series**  
Split Case Double Suction Centrifugal Pump  
Mechanical Seal Applications for SPLT.M



**Mas Grup**

**BURGMANN M3N**

- Single Seal
- Unbalanced
- Conical Spring
- Dependent on direction of rotation
- To EN 12756

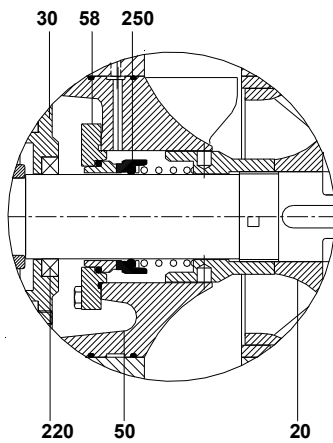

p <sub>1</sub>	: 10 Bar
t	: -20...180 °C
V <sub>g</sub>	: 10 m/s
Axial Movement	: ±1,0 mm

Part No	Part Name
20	Impeller
30	Bearing Housing
50	Stuffing Box
58	Mech. Seal Cover
220	Oil Seal
250	Mechanical Seal

**BURGMANN MG1**

- Single Seal
- Unbalanced
- Elastomer Bellows
- Independent on direction of rotation

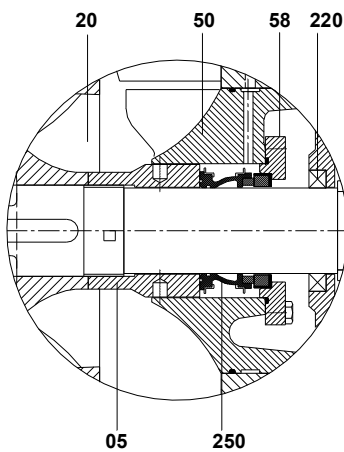

p <sub>1</sub>	: 12 Bar
t	: -20...120 °C
V <sub>g</sub>	: 10 m/s

Part No	Part Name
20	Impeller
05	Wearing Ring
50	Stuffing Box
58	Mech. Seal Cover
220	Oil Seal
250	Mechanical Seal

**SPLT & SPLT.M Series**  
Split Case Double Suction Centrifugal Pump  
Installation Types



**Mas Grup**

**Horizontal Installation with Diesel**

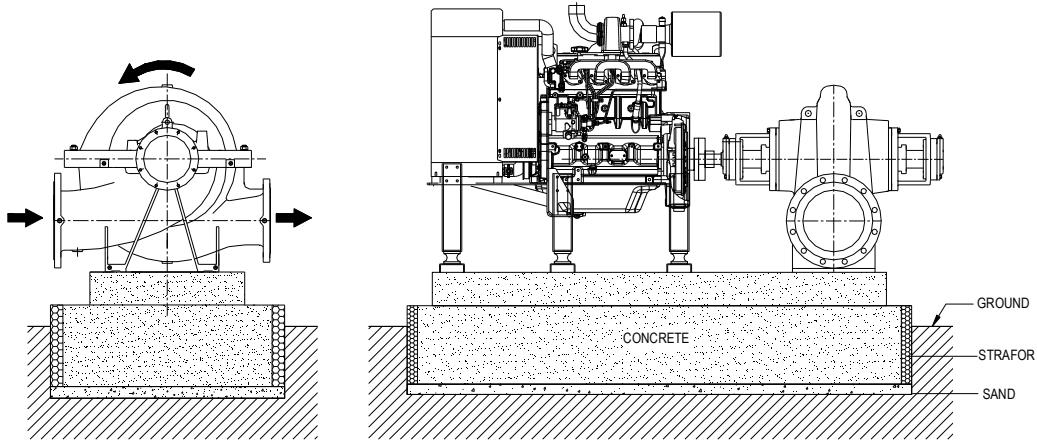

**Horizontal Installation with Electric Motor**

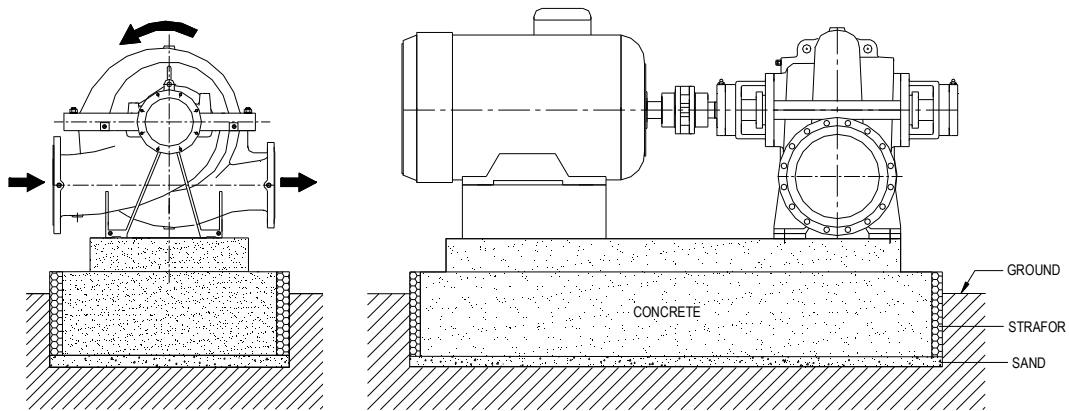

**Direction of Rotation / Flow**

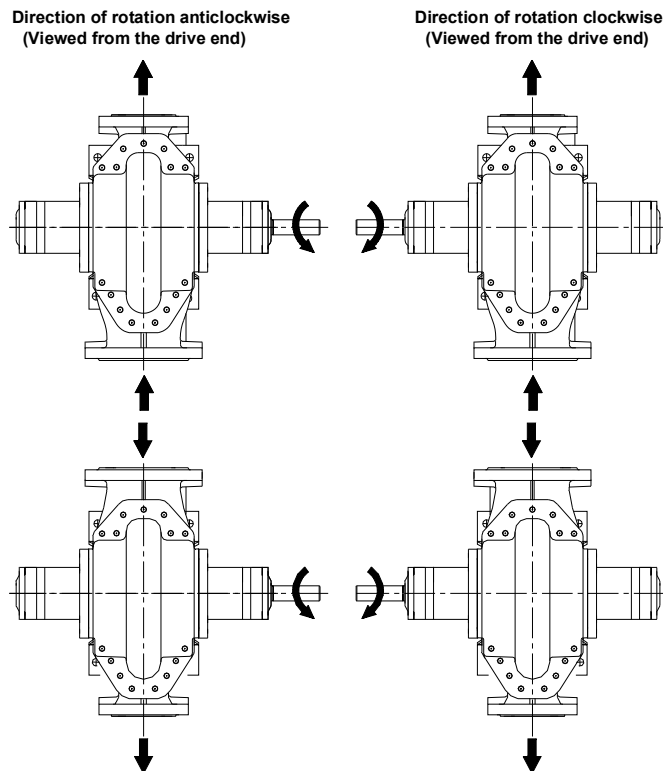

**SPLT & SPLT.M Series**  
Split Case Double Suction Centrifugal Pump  
Technical Data

**Material Options**

Components	Material. No						
		0.6025	0.7040	2.1050.01	1.4021	1.4301	1.4401
Casing		●	○	○		○	○
Impeller		●	○	○		○	○
Shaft					●	○	○
Casing Wear Ring				●	○	○	○
Stuffing Box		●	○	○		○	○
Gland			●	○		○	○
Bearing Housing		●					
Bearing Cover		●					

● – Standard Manufacturing  
○ – Optional

**Material Equivalent**

Description	DIN 17007	EN-DIN	ASTM
Cast Iron	0.6025	GJL-250 (GG25)	A 48 Class 40-B
Nodular Cast Iron	0.7040	GJS-400-15 (GGG40)	A 536 Gr.60-40-18
Cast Bronze	2.1050.01	G-Cu Sn 10	B 584 C 90700
Chrome Steel	1.4021	X20 Cr 13	A 276 Type 420
Chrome Nickel Steel	1.4301	X5 Cr Ni 18.9	A 276 Type 304
Chrome Nickel Molybdenum Steel	1.4401	X5 Cr Ni Mo 18.10	A 276 Type 316

**PN 16 Flange Dimension**

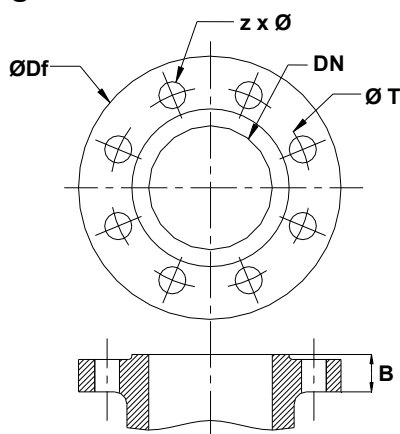

DN mm ø	Df mm ø	T mm ø	Z Each	ø mm ø	B mm
DN 65	185	145	4	18	20
DN 80	200	160	8	18	22
DN 100	220	180	8	18	24
DN 125	250	210	8	18	26
DN 150	285	240	8	23	26
DN 200	340	295	12	23	30
DN 250	405	355	12	27	32
DN 300	460	410	12	27	32
DN 350	520	470	16	27	36
DN 400	580	525	16	30	38

**PN 10 Flange Dimension**

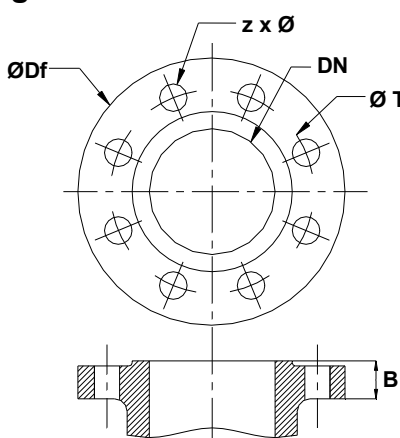

DN mm ø	Df mm ø	T mm ø	Z Each	ø mm ø	B mm
DN 250	395	350	12	23	28
DN 300	445	400	12	23	28
DN 350	505	460	16	23	30
DN 400	565	515	16	27	32
DN 500	670	620	20	27	34

**SPLT & SPLT.M Series**  
Split Case Double Suction Centrifugal Pump  
Technical Data

**Pump Flange Classification**

Pump Type	Flanges	
	DNs (mm) (Suction)	DNd (mm) (Discharge)
65-250	100	65
80-250	125	80
80-360	125	80
100-250	150	100
100-315	150	100
150-250	200	150
125-400	150	125
150-315	200	150
150-400	200	150
150-500	200	150
200-315	250	200
200-400	250	200
200-500	250	200
250-315	300	250
250-400	300	250
250-500	300	250
350-400	400	350
350-500	400	350
500-500	500	500

**Salmastra Kutusu Ve Salmastra Burcu O-Ring Boyutları**

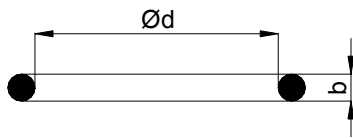

**Stuffing Box O-Ring**

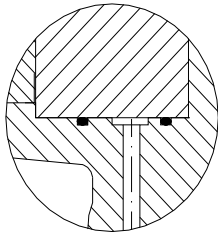

**Seal Sleeve O-Ring**

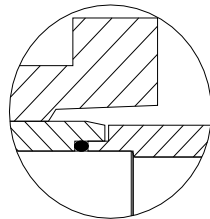

Pump Type	O-Ring for Stuffing Box			O-Ring for Seal Sleeve		
	Ød (mm)	b (mm)	Qty	Ød (mm)	b (mm)	Qty
65-250	-	-	-	30		
80-250	145	3	3	43	3	2
80-360				43		
100-250				50		
100-315	168	3	4	50	3	2
125-400	190			60		
150-315				60		
150-400		60				
150-500	200	4	4	60	3	2
200-315				70		
200-400				70		
200-500	260	4	4	70	3	2
250-400				80		
250-315				80		
250-500	260	4	4	80	3	2
350-400				80		
350-500				80		
500-500	260	4	4	80	3	2

**Note:** There are O-rings both for stuffing boxes and seal sleeves at SPLT. However, since there is no seal sleeve, there are only O-rings for stuffing boxes at SPLT.M.

## SPLT & SPLT.M Series

Split Case Double Suction Centrifugal Pump

### Technical Data



Mas Grup

### Keys for SPLT and SPLT.M (DIN 6885 A)

Pump Type	Impeller Key (mm)	Coupling Key (mm)	Material
65-250	10x8x40	8x7x55	St 50
80-250	12x8x116	10x8x75	
80-360	12x8x116	10x8x75	
100-250	12x8x116	10x8x75	
100-315	14x9x132	14x9x105	
125-400	16x10x124	16x10x100	AISI 304
150-315	16x10x124	16x10x100	
150-400	16x10x124	16x10x100	
150-500	16x10x124	16x10x100	
200-315	16x10x154	16x10x100	AISI 316
200-400	16x10x154	16x10x100	
200-500	16x10x180	18x11x135	
250-400	16x10x180	18x11x135	
250-315	16x10x200	18x11x135	
250-500	16x10x200	18x11x135	
350-400	20x12x205	20x12x135	

Key material AISI 304 and AISI 316 are optional.

### Studs for SPLT and SPLT.M

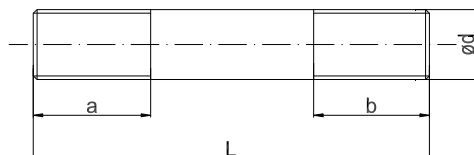

Pump Type	Stud for Casing				Stud for Gland				Material
	D	a	b	L	d	a	b	L	
65-250	M12	15	20	55	M10	25	15	65	C 22 B AISI 304 AISI 316
80-250	M14	20	25	70	M12	25	15	70	
80-360	M14	20	25	70	M12	25	15	70	
100-250	M14	20	25	75	M12	25	15	70	
100-315	M14	20	30	65	M14	30	20	80	
125-400	M20	35	30	95	M14	30	25	130	
150-315	M20	35	30	95	M14	30	25	130	
150-400	M20	35	30	95	M14	30	25	130	
150-500	M20	35	30	95	M14	30	25	130	
200-315	M20	30	30	95	M14	30	25	130	
200-400	M20	40	30	95	M14	30	25	130	
200-500	M20	40	30	95	M16	35	30	130	
250-400	M20	40	30	95	M16	35	30	130	
250-315	M20	40	30	95	M16	35	30	130	
250-500	M24	40	30	95	M16	35	30	130	
350-400	M27	40	30	110	M20	35	30	130	

Stud material AISI 304 and AISI 316 are optional.

**Note:** Since there is no gland for SPLT.M, SPLT.M type does not contain stud for gland.

**SPLT & SPLT.M Series**  
Split Case Double Suction Centrifugal Pump  
Technical Data

**Gland for SPLT**

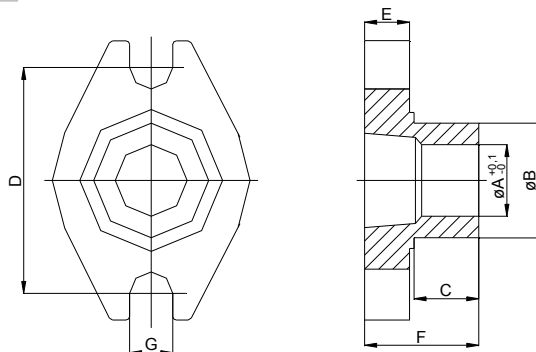

Pump Type	Ø A (mm)	ØB (mm)	C (mm)	D (mm)	E (mm)	F (mm)	ØG (mm)	Material
65-250	37	47	19	88	15	34	15	Ductile Iron GGG 40  Bronze G-CuSn 10
80-250	55,5	75	19	115	16	35	14	
80-360	55,5	75	19	115	16	35	14	
100-250	55,5	75	19	115	16	35	14	
100-315	55,5	89	31	145	20	51	16	
125-400	65,5	106	30	155	22	52	16	
150-315	78,5	106	30	155	22	52	16	
150-400	78,5	106	30	155	22	52	16	
150-500	78,5	106	30	155	22	52	16	
200-315	78,5	106	30	155	22	52	16	
200-400	78,5	106	30	155	22	52	16	
200-500	78,5	106	30	170	22,5	52,5	18	
250-400	88,5	116	30	170	22,5	52,5	18	
250-315	88,5	116	30	170	22,5	52,5	18	
250-500	88,5	116	30	170	22,5	52,5	18	
350-400	103	140	30	185	24	54	23	

**Bolts for SPLT and SPLT.M (DIN 931)**

PumpType	Bearing Cover Bolt	Qty.	Bearing Housing Bolt	Qty.	Material
65-250	M6x20	8	M10x30	8	C 22 B  AISI 304  AISI 316
80-250	M8x30	8	M10x35	8	
80-360	M8x30	8	M10x35	8	
100-250	M8x30	8	M10x35	8	
100-315	M10x30	8	M10x35	8	
125-400	M10x85	8	M12x45	8	
150-315	M10x85	8	M12x45	8	
150-400	M10x85	8	M12x45	8	
150-500	M10x85	8	M12x45	8	
200-315	M10x85	8	M12x45	8	
200-400	M10x85	8	M12x45	8	
200-500	M10x85	12	M12x45	16	
250-400	M10x85	12	M12x45	16	
250-315	M10x85	12	M12x45	16	
250-500	M10x85	12	M12x45	16	
350-400	M12x115	16	M16x60	16	

**Plugs, Greaser and Adjusting Taps for SPLT and SPLT.M Pumps**

Pump Type	Casing Plug	Qty.	Bearing Housing Plug	Qty.	Material	
65-250	R 1/2"	1	R 1/2"	2	Ms 58	
80-250		2				
80-360						
100-250		5	R 3/8"			
100-315						1
125-400						
150-315						
150-400						
150-500						
200-315						
200-400						
200-500						
250-400						
250-315						
250-500						
350-400						

Pump Type	Adjusting Taps	Qty.	Flange Plug	Qty.	Material
65-250	-	-	-	-	-
80-250	R 3/8"	1	R 3/8"	1	Ms 58
80-360					
100-250					
100-315		2	R 1/2"		
125-400					
150-315					
150-400					
150-500					
200-315					
200-400					
200-500					
250-400					
250-315					
250-500					
350-400					

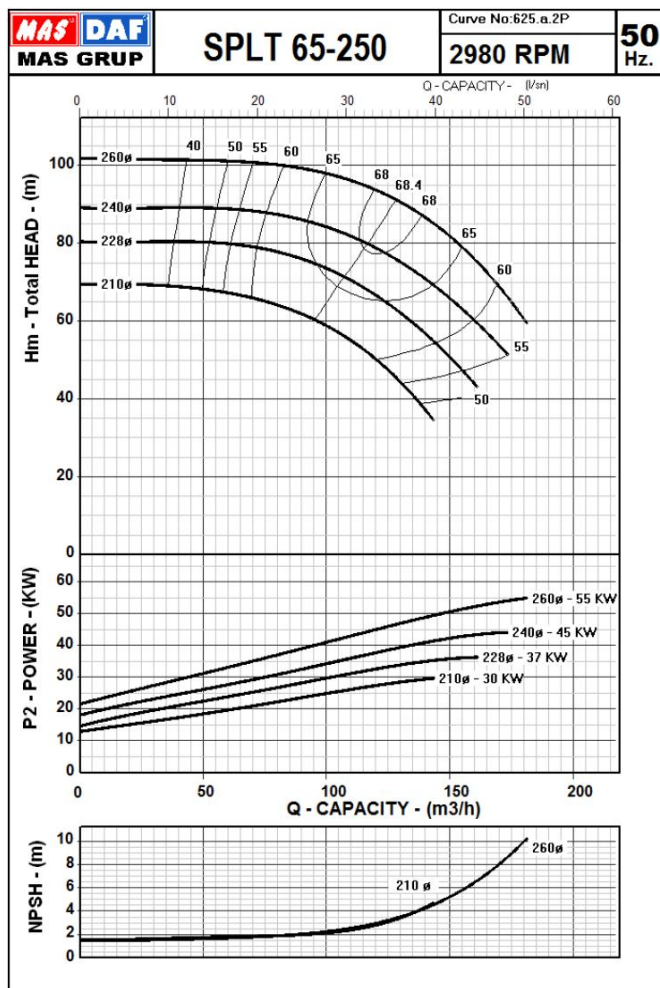
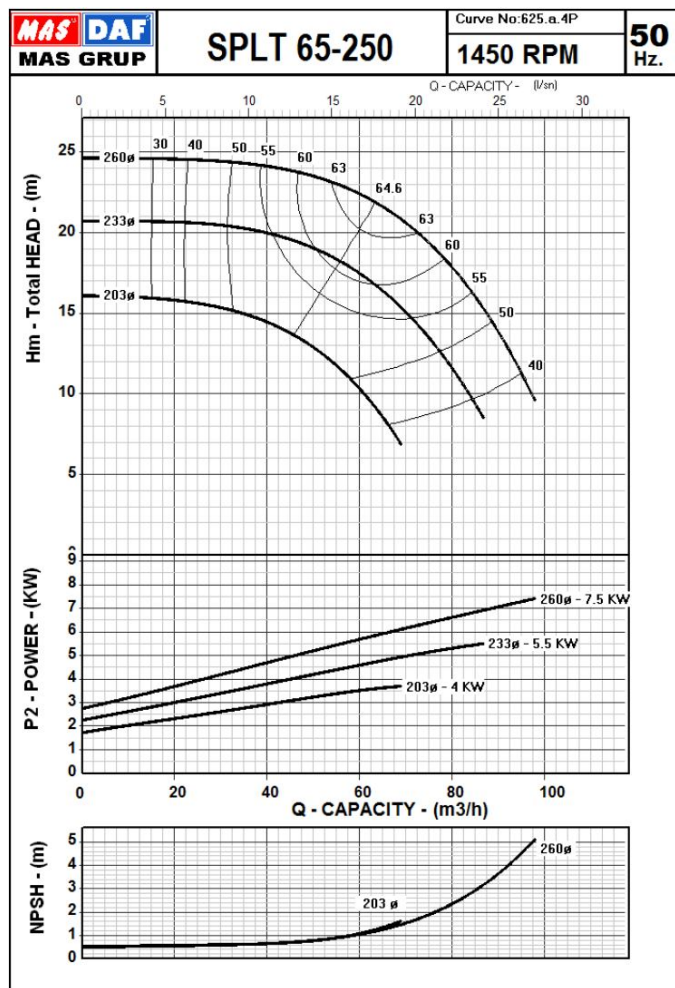



**SPLIT & SPLIT.M Series**  
Split Case Double Suction Centrifugal Pump  
Performance Range **SPLT 80-360**



**Mas Grup**

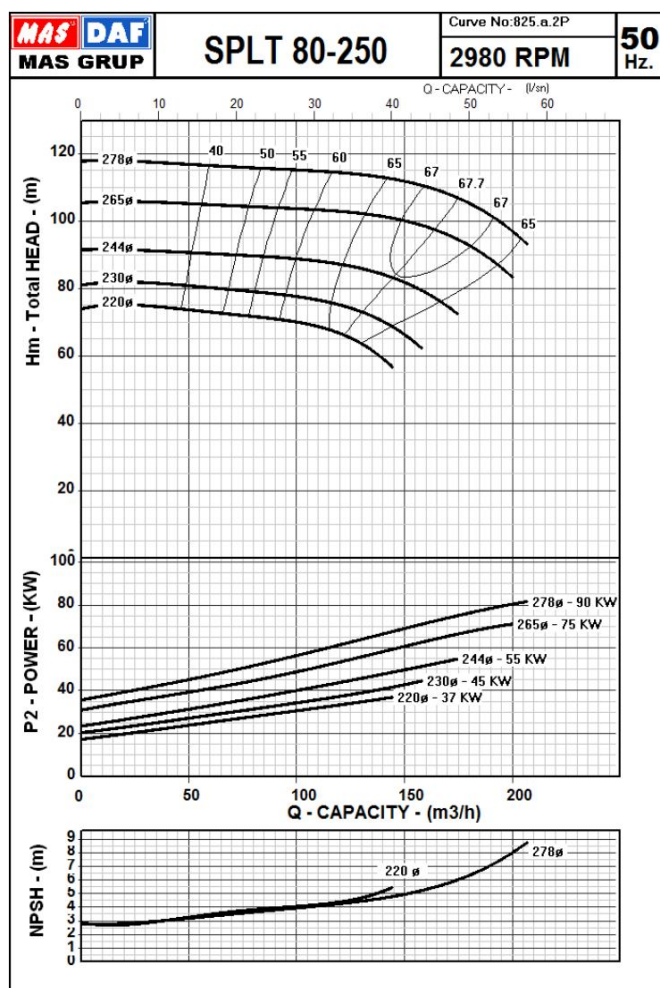
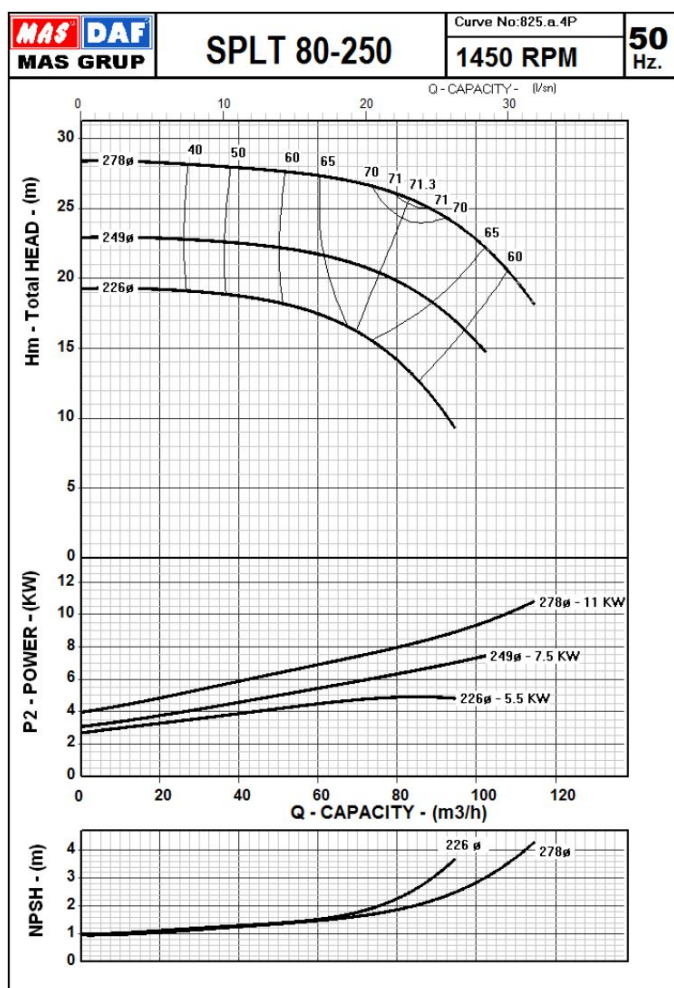

**SPLIT CASE SPLT.M Series**  
Split Case Double Suction Centrifugal Pump  
Performance Range **SPLT 80-360**



**Mas Grup**

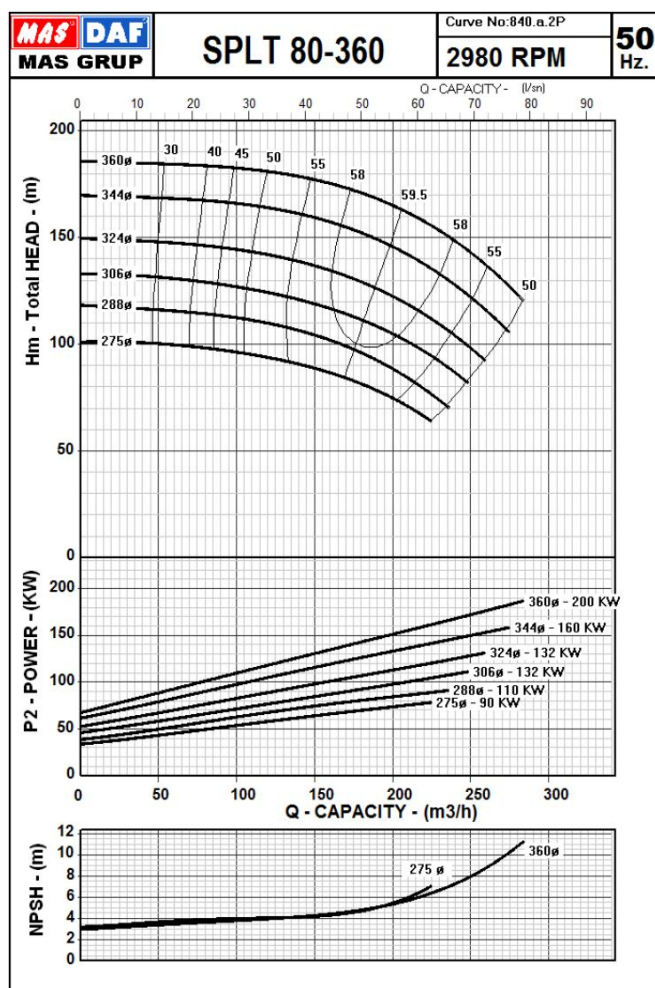
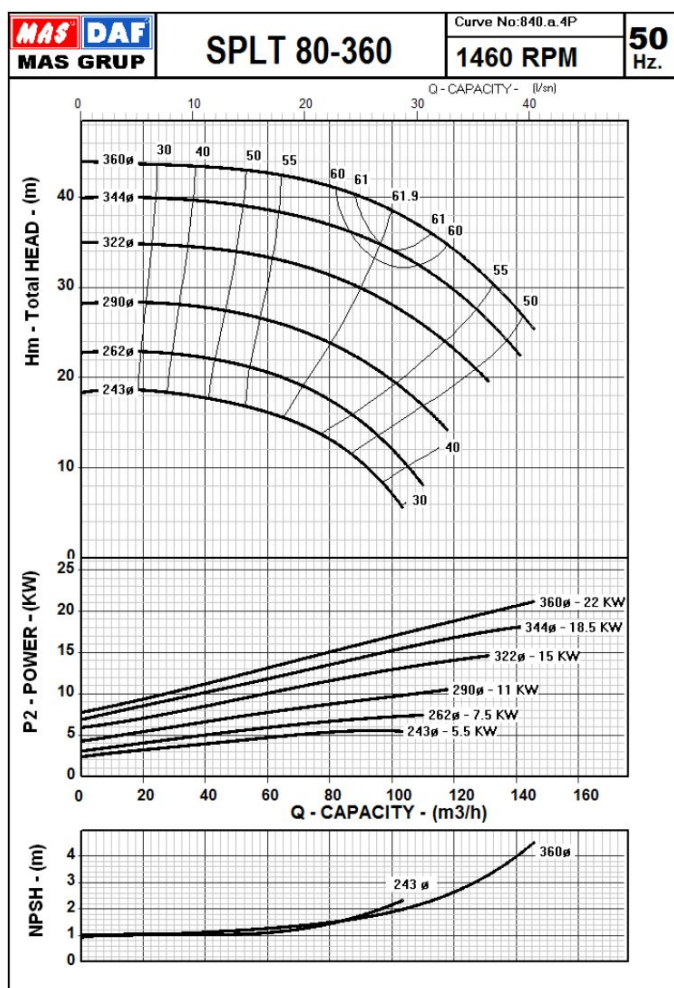

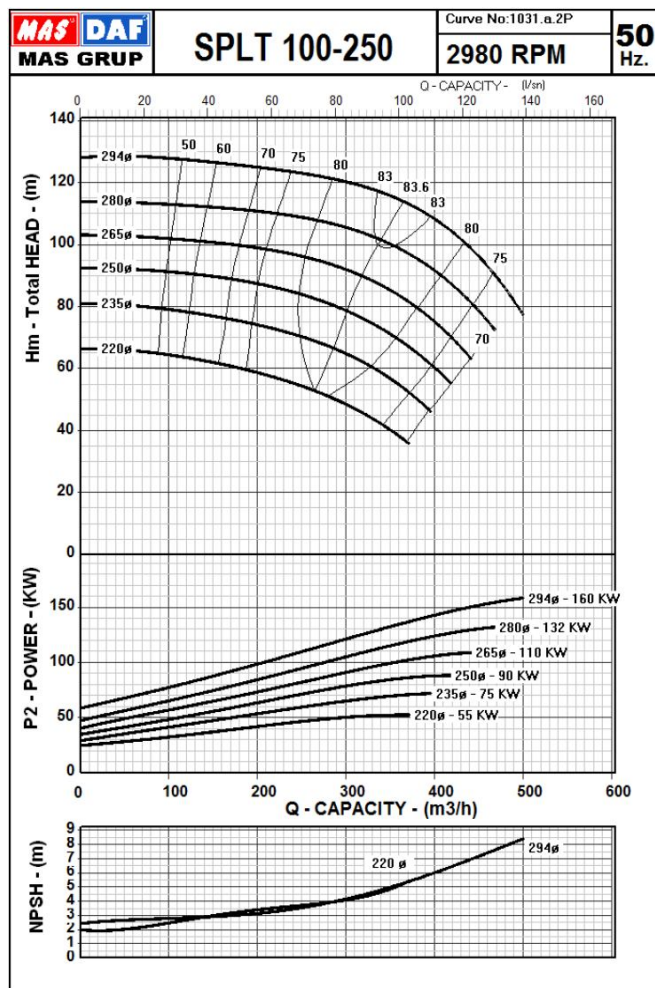
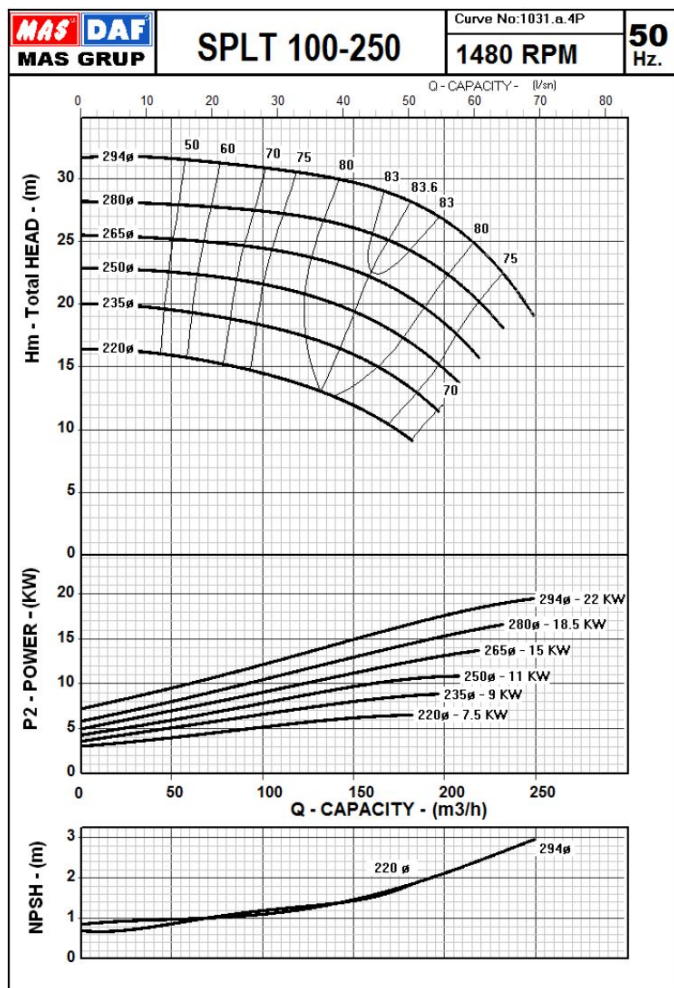

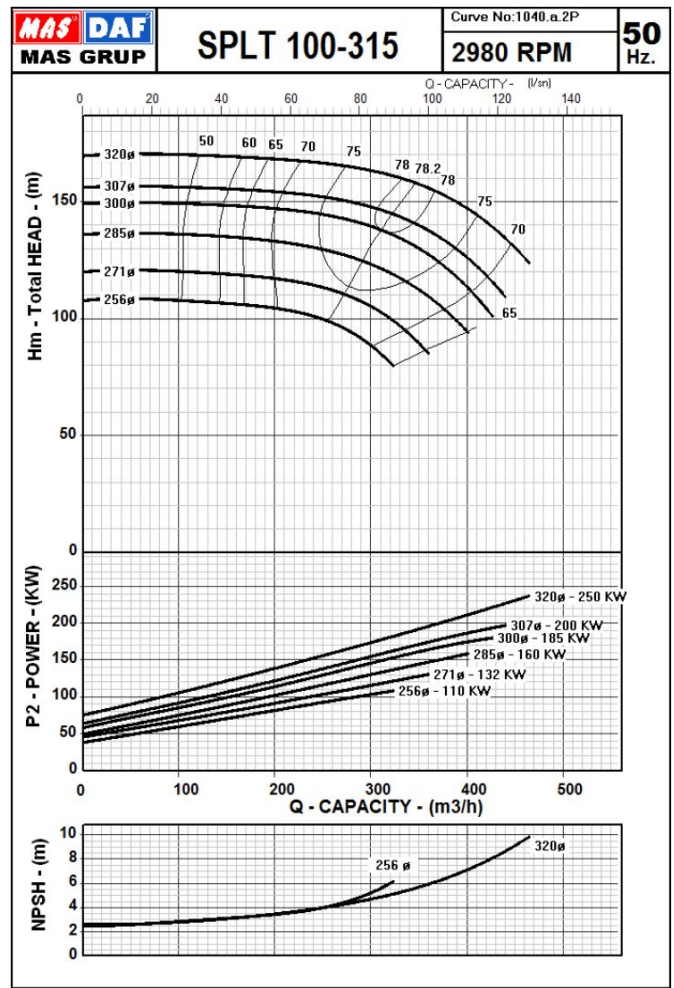
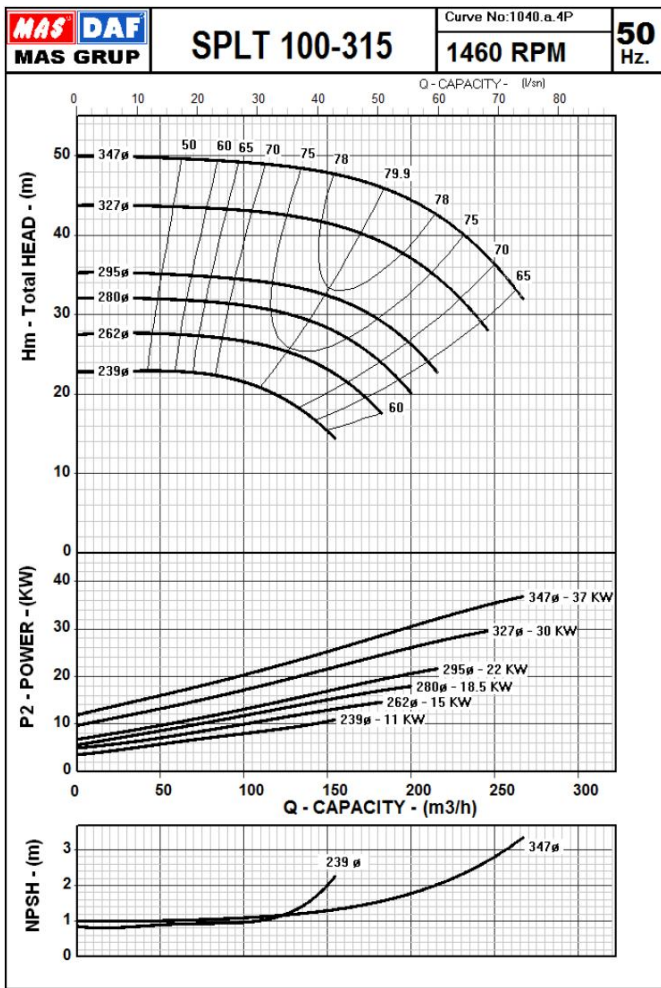

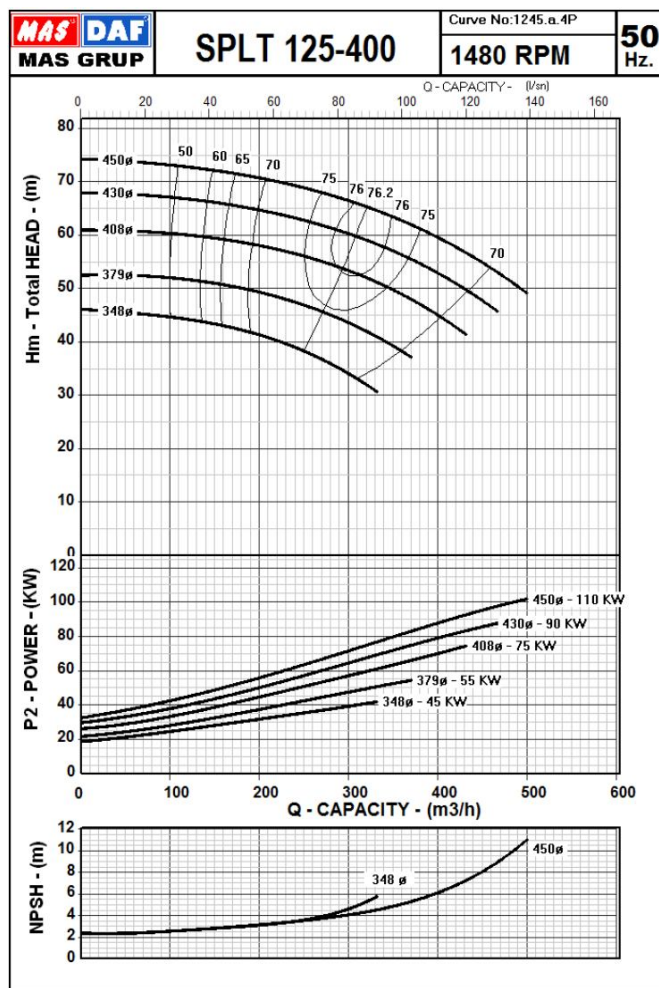
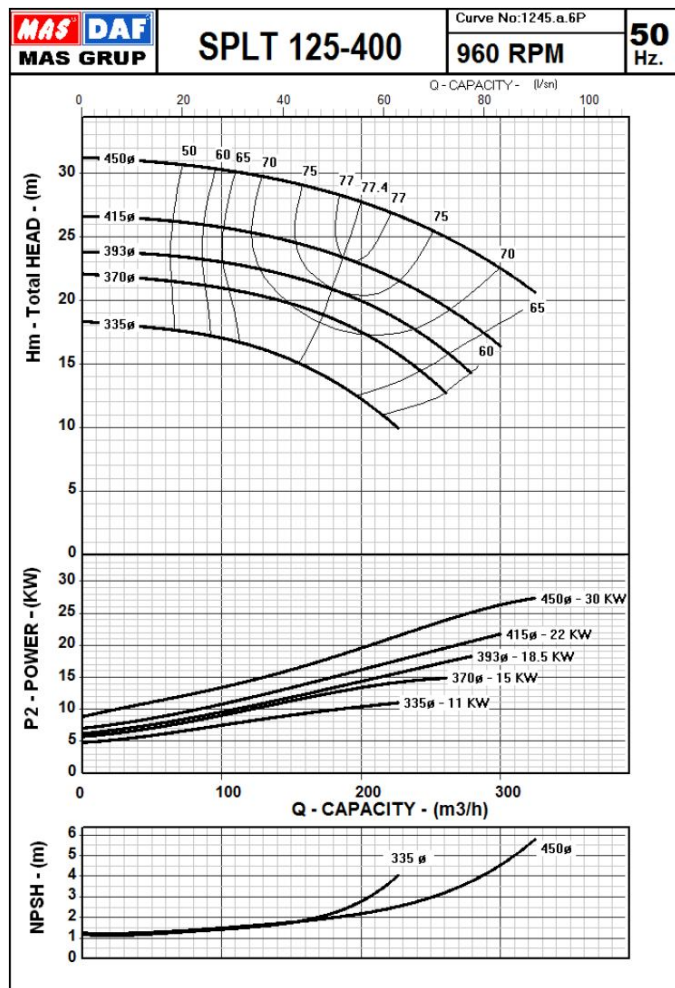

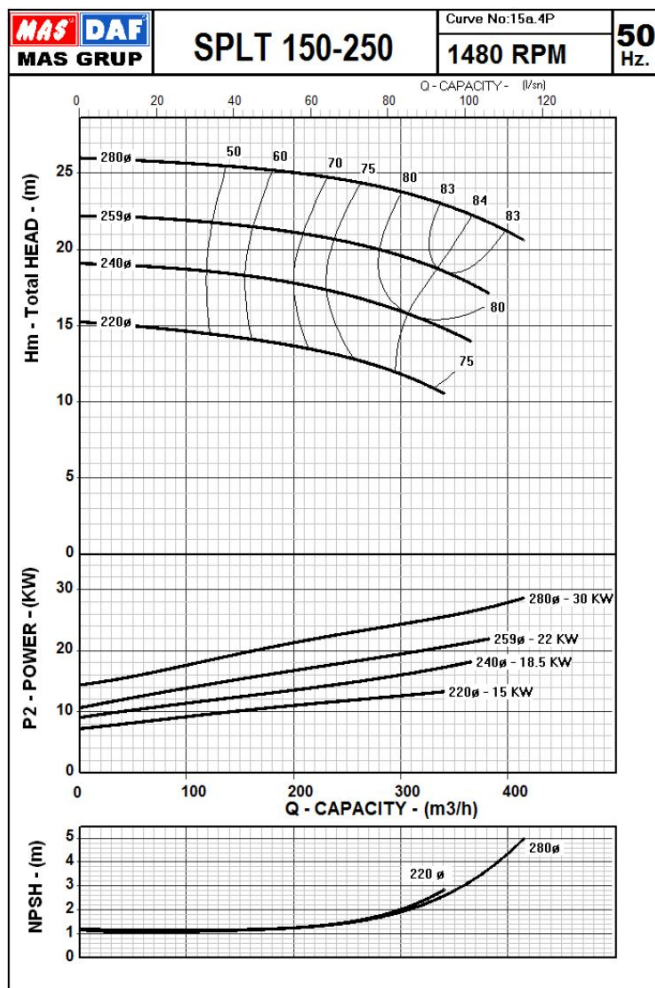
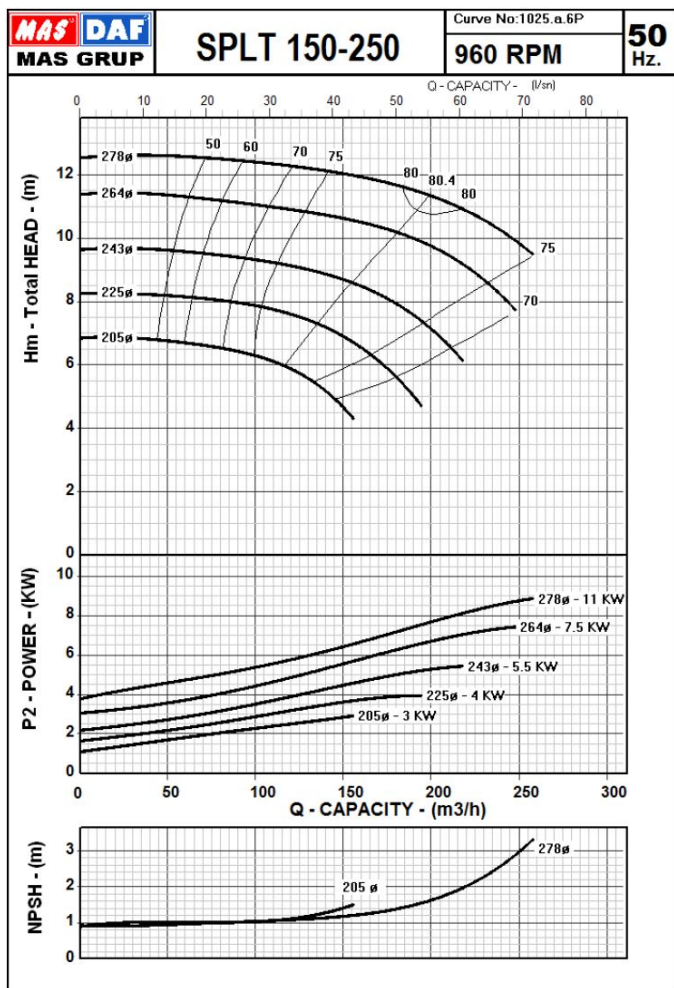

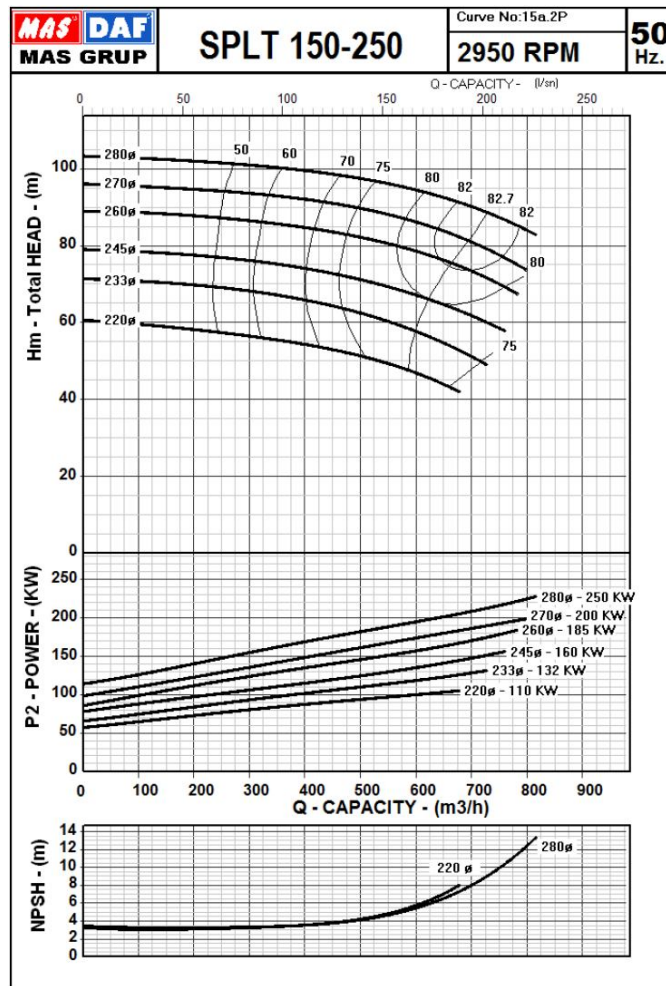

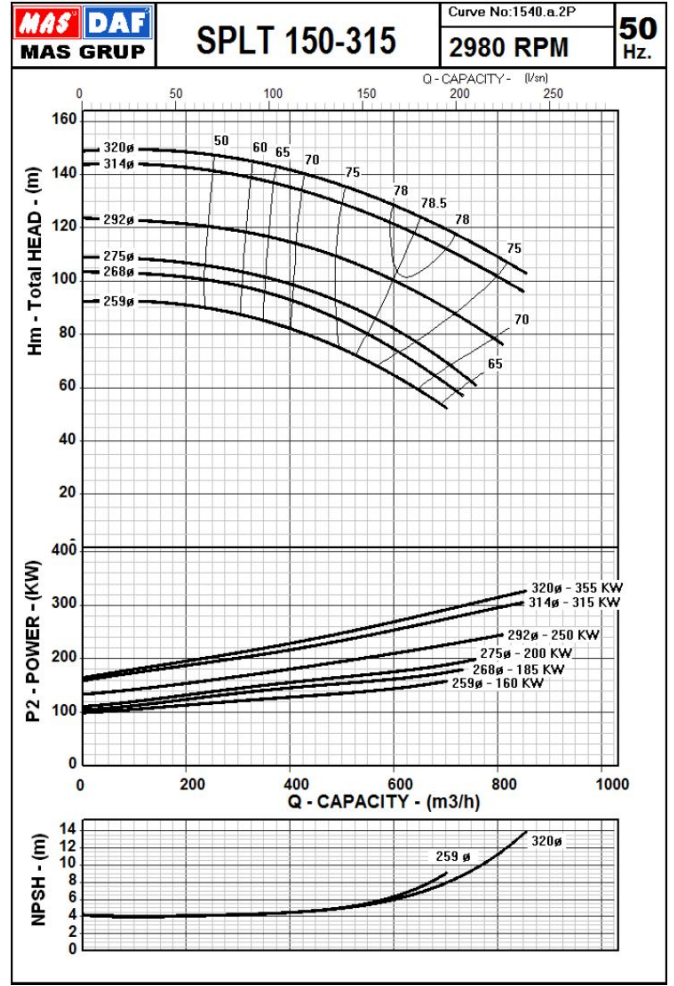
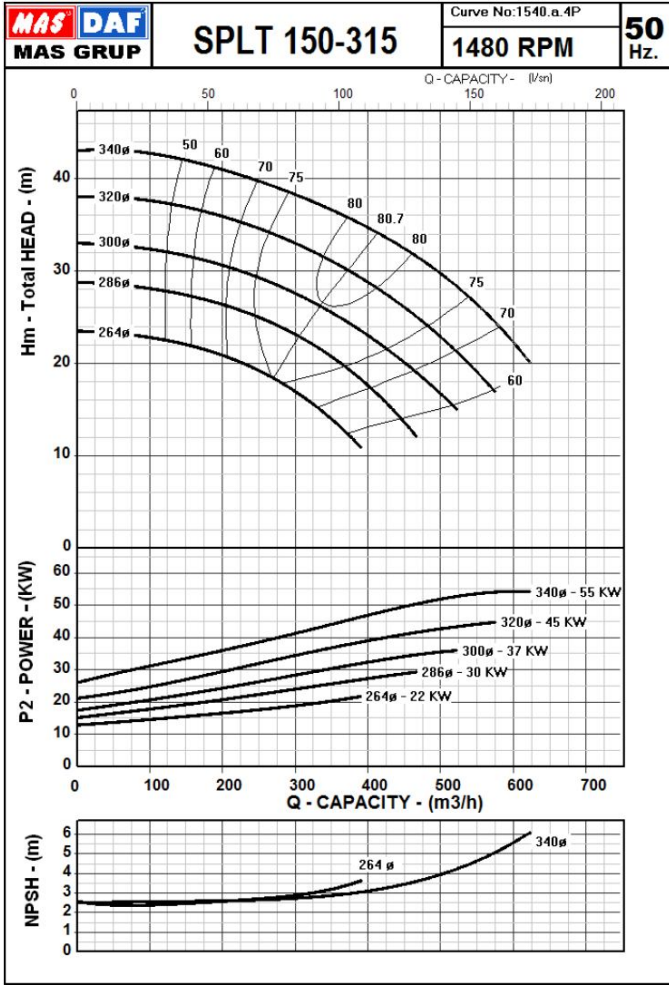



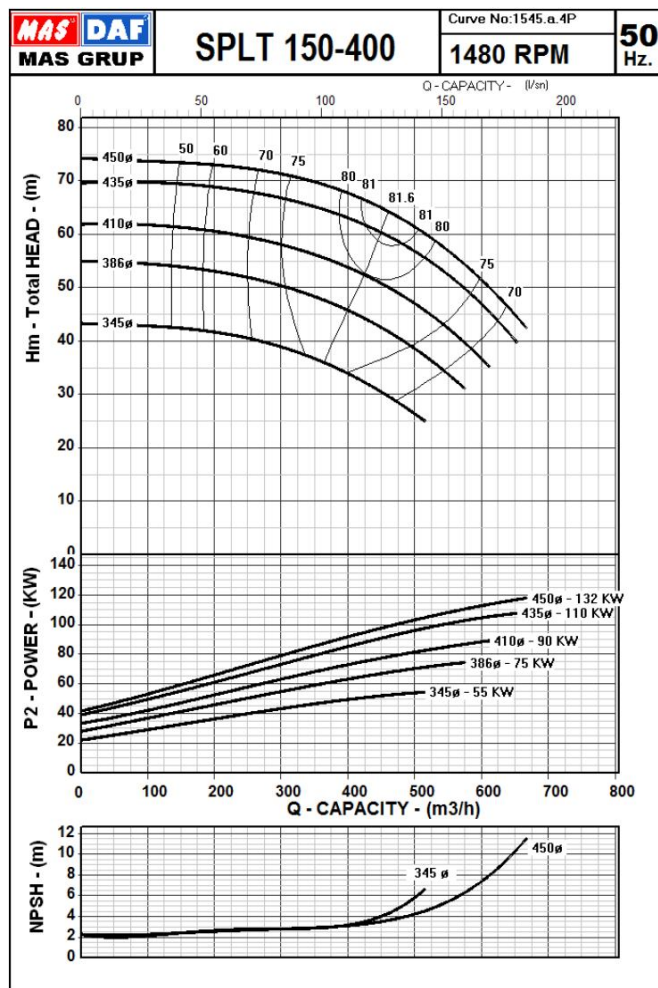
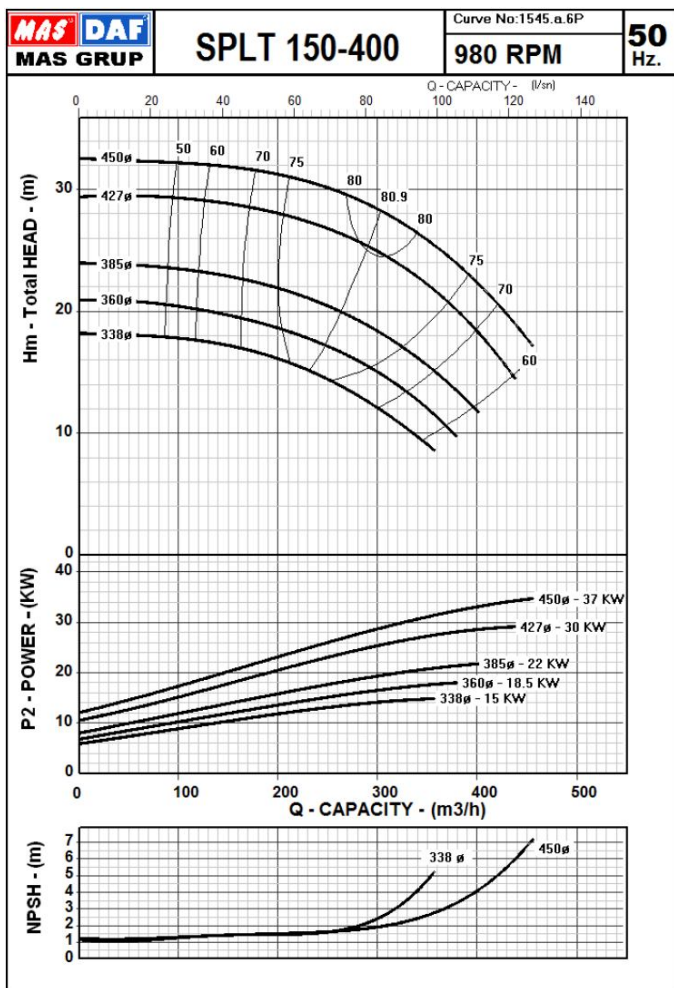

**SPLIT & SPLIT.M Series**  
Split Case Double Suction Centrifugal Pump  
Performance Range

**SPLT 150-500**



**Mas Grup**

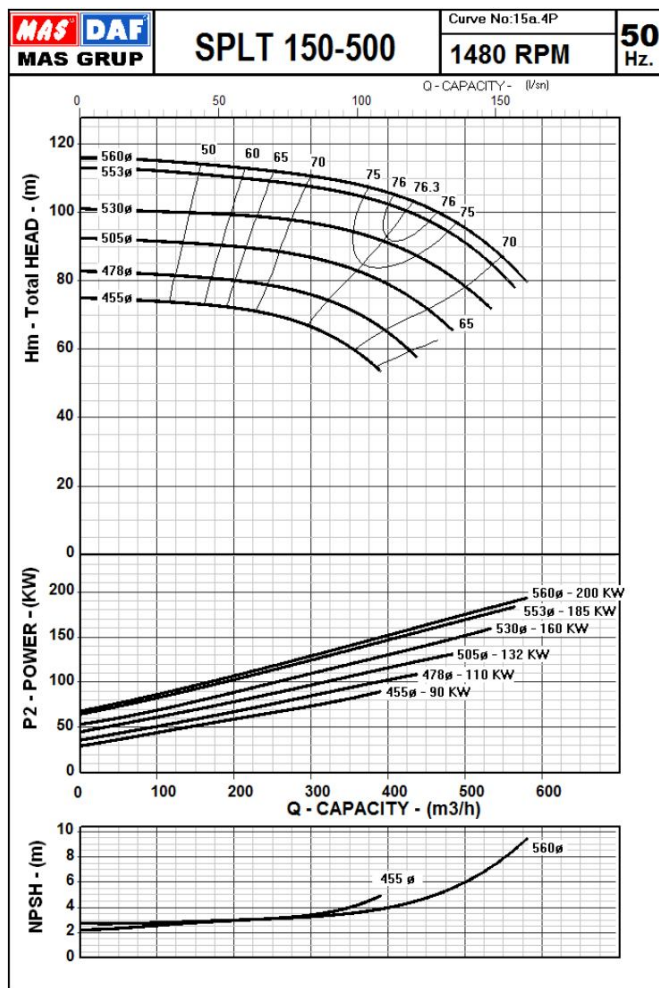
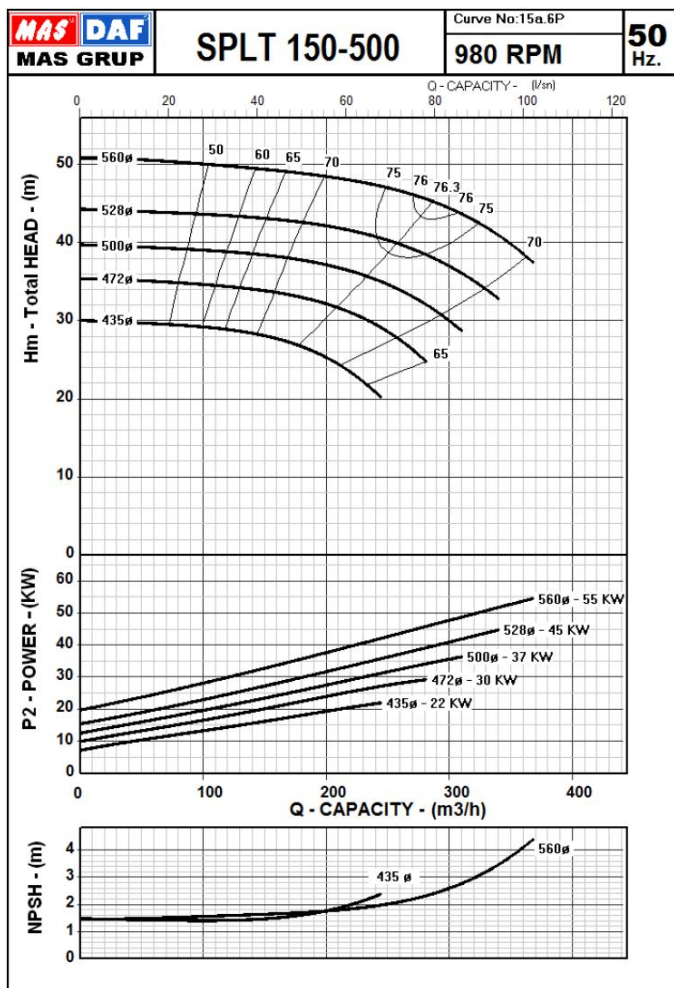

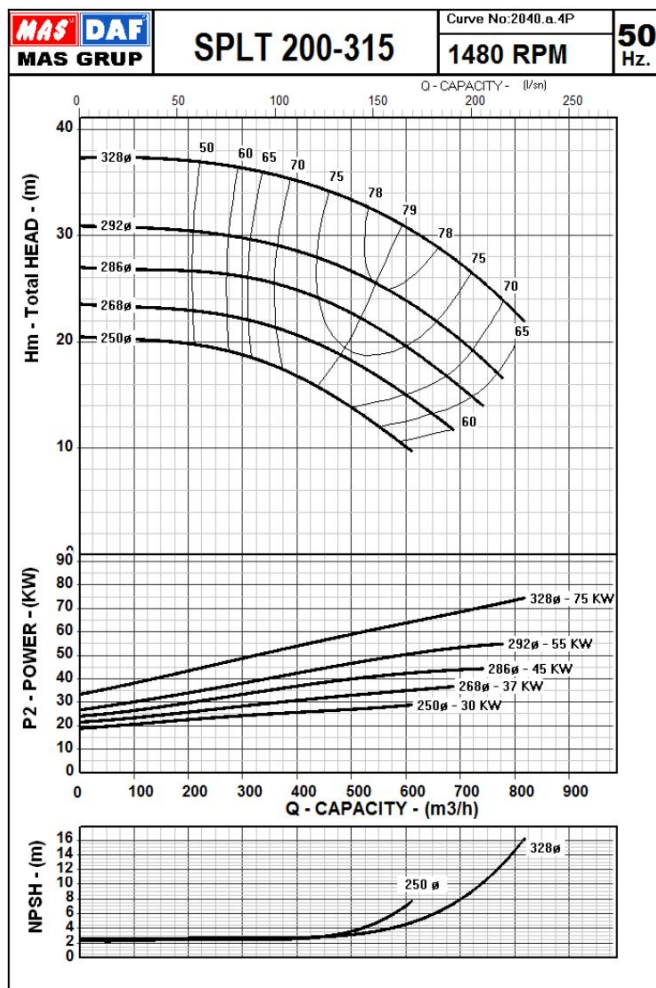
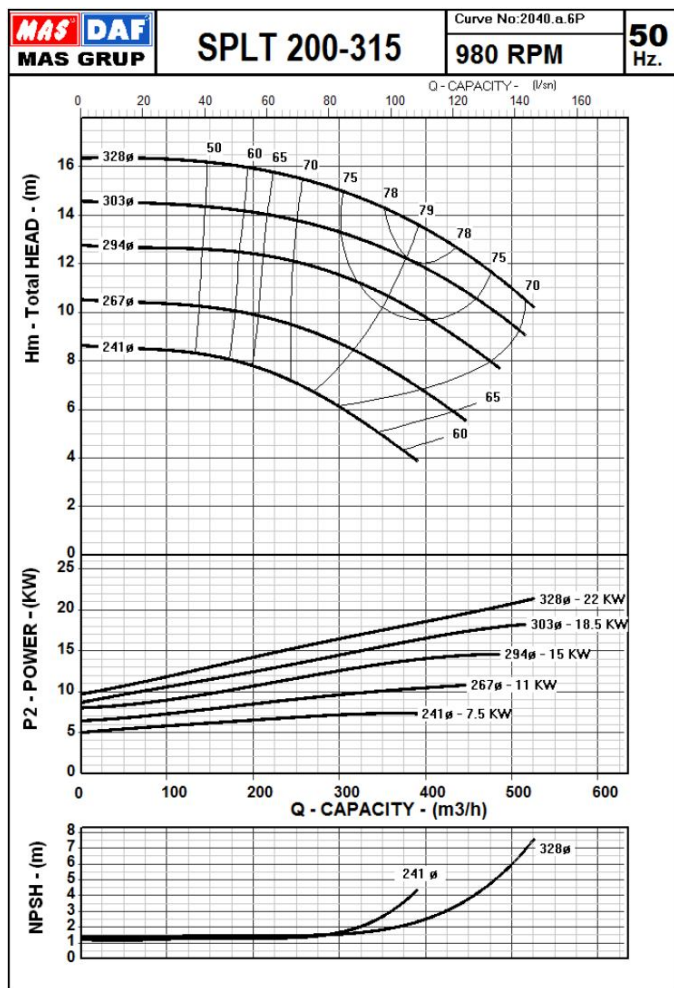

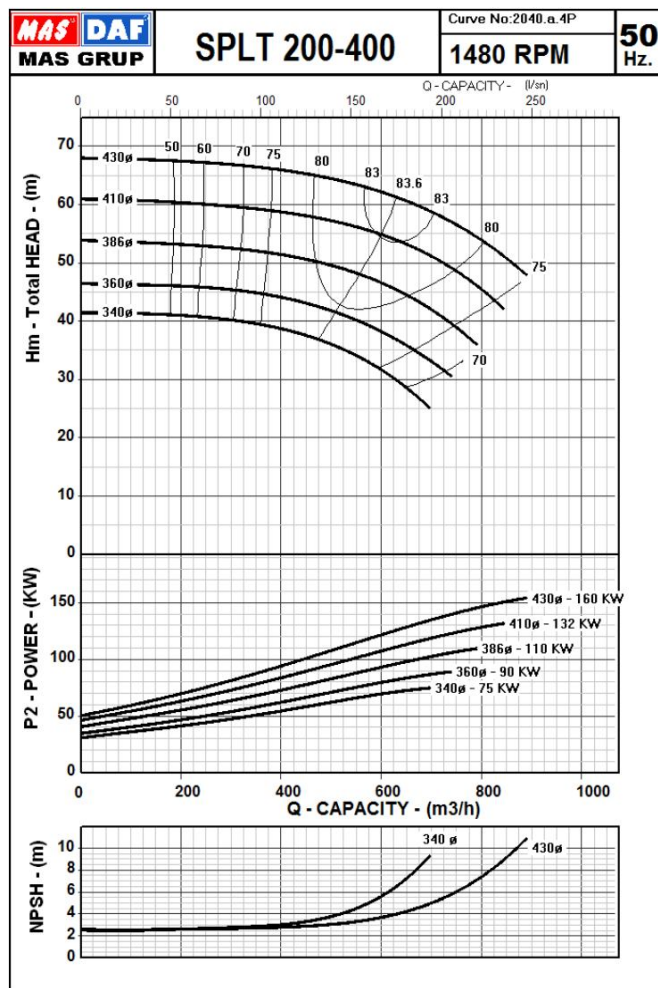
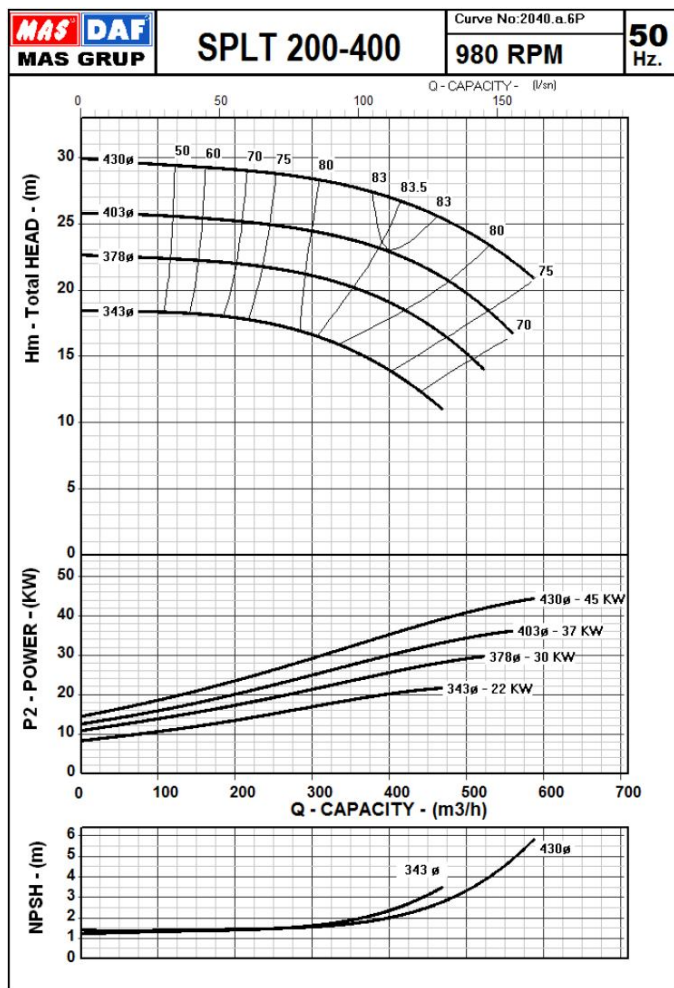

**SPLIT CASE SPLT.M Series**  
Split Case Double Suction Centrifugal Pump  
Performance Range

**SPLT 200-500**



**Mas Grup**

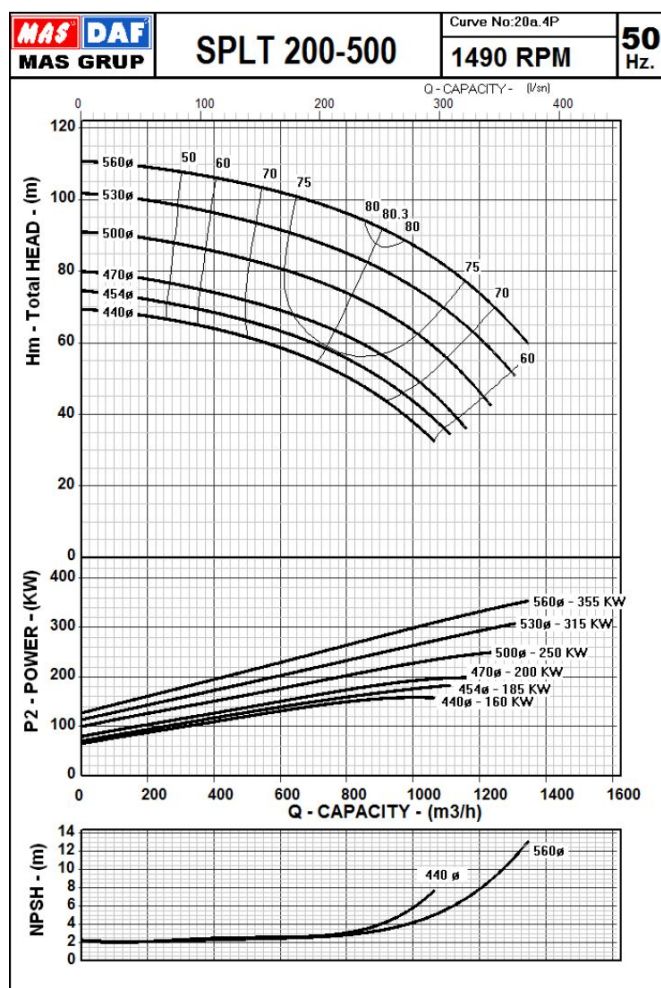
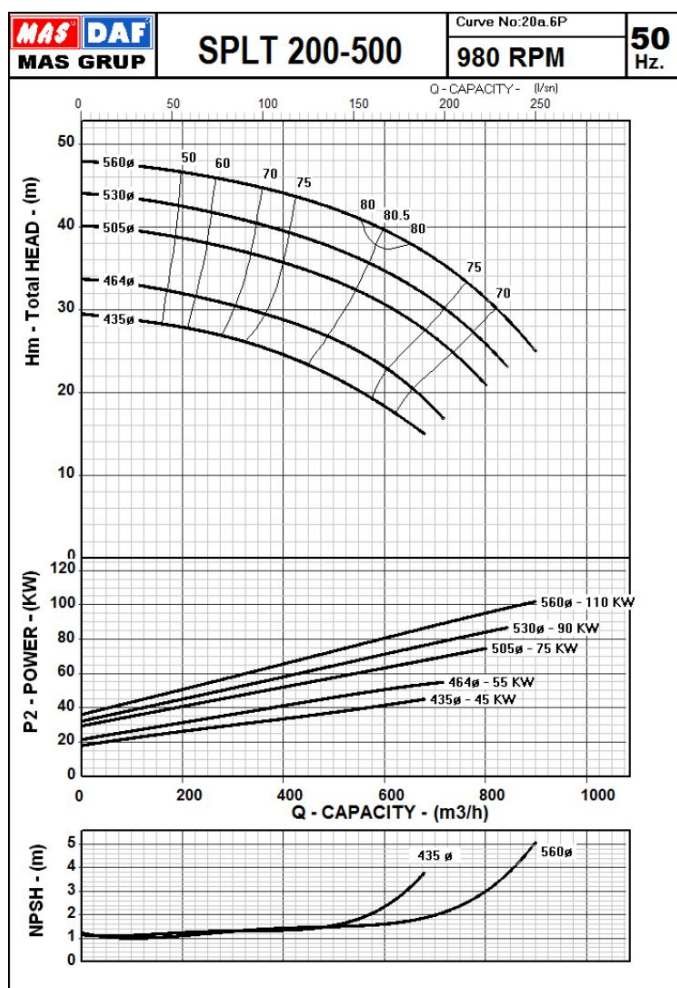

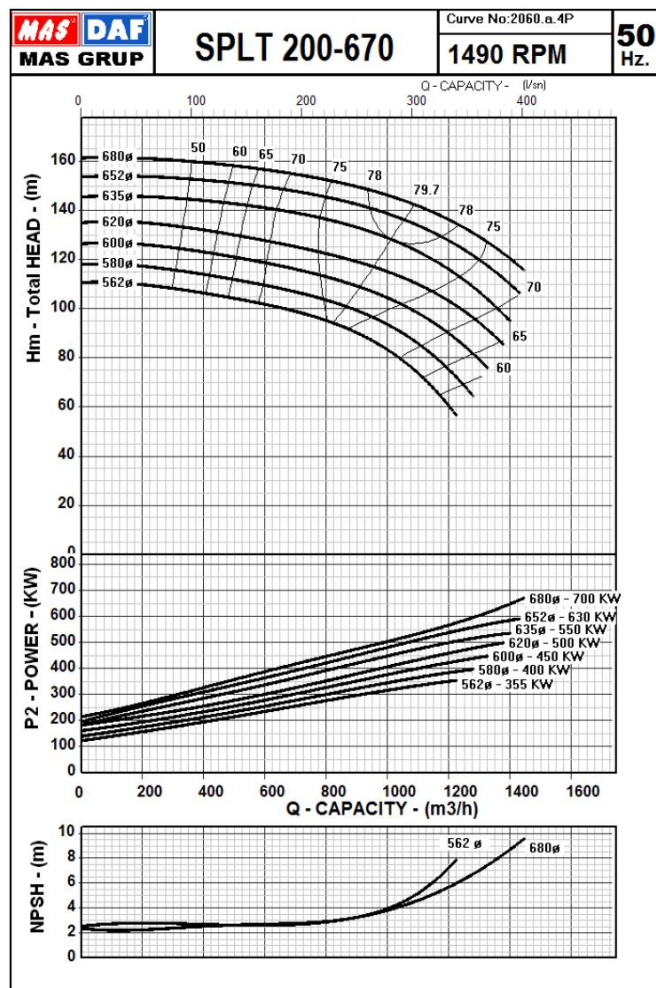
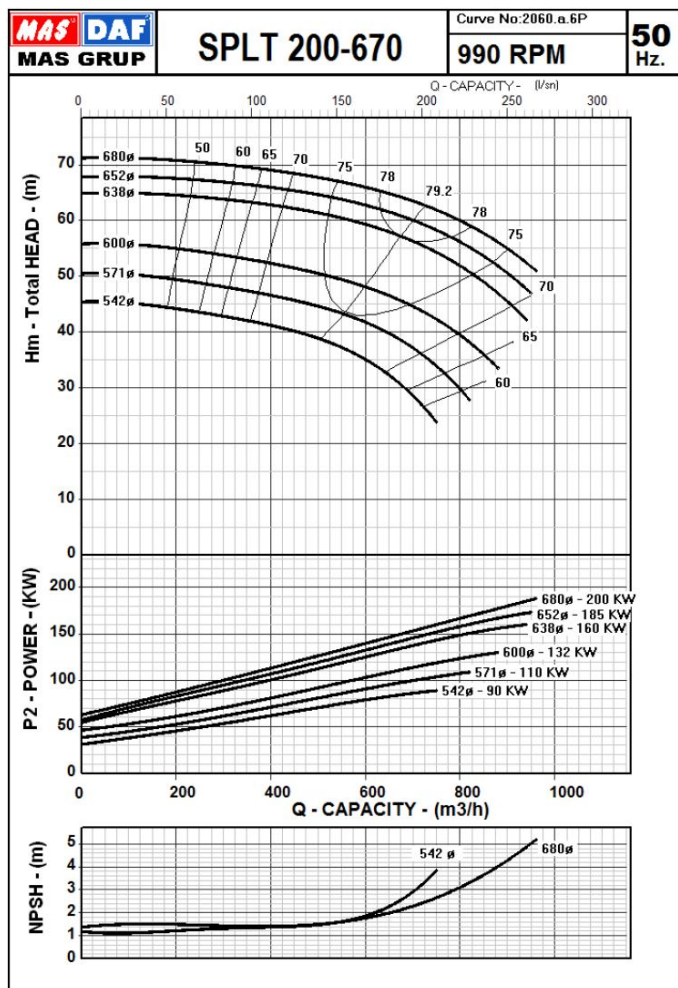

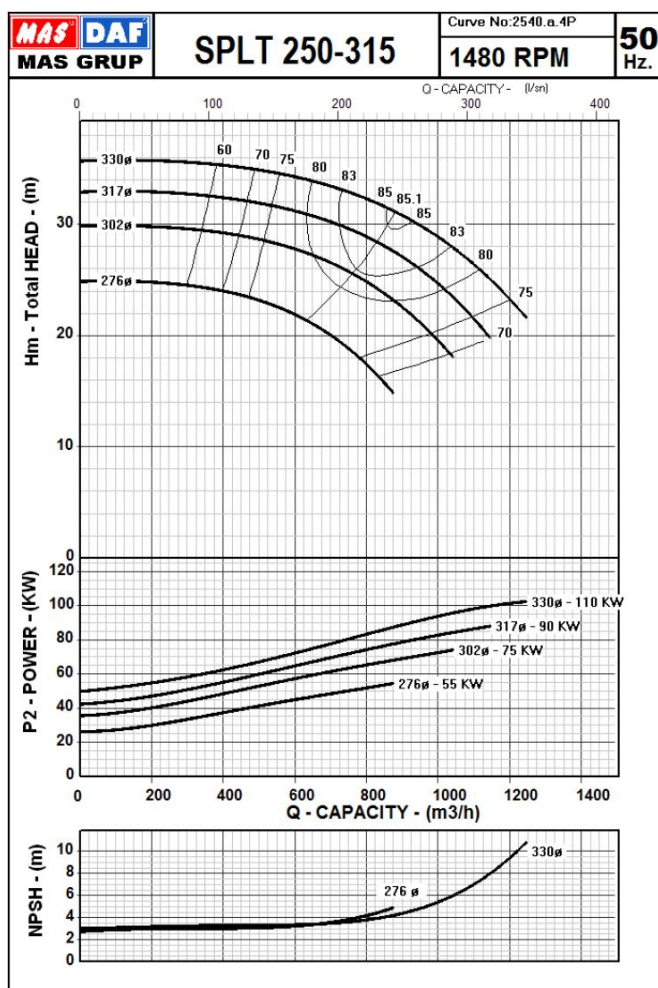
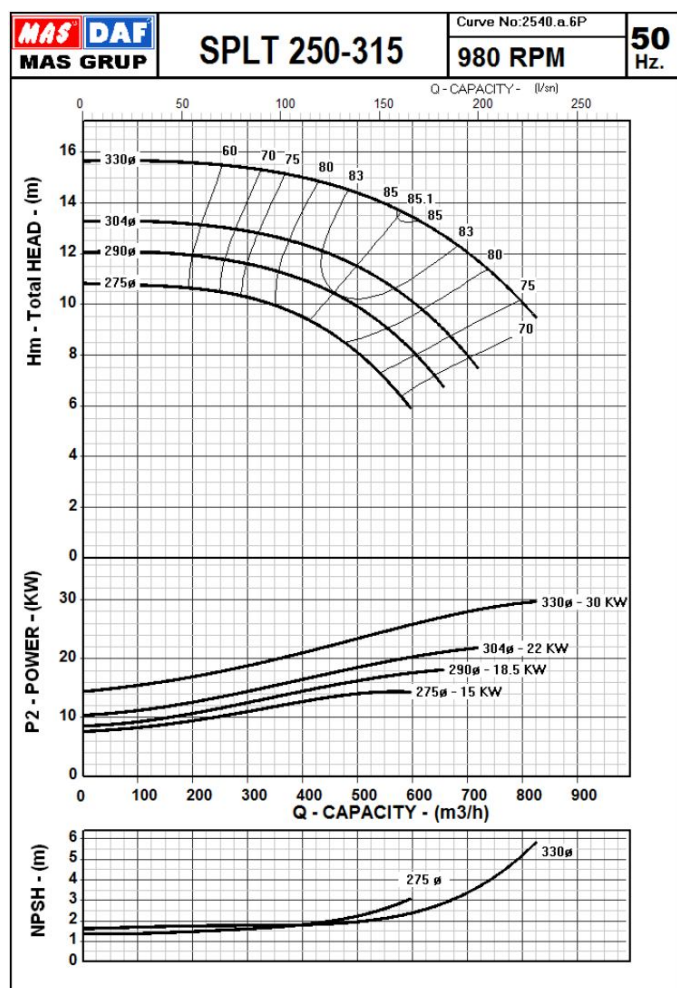

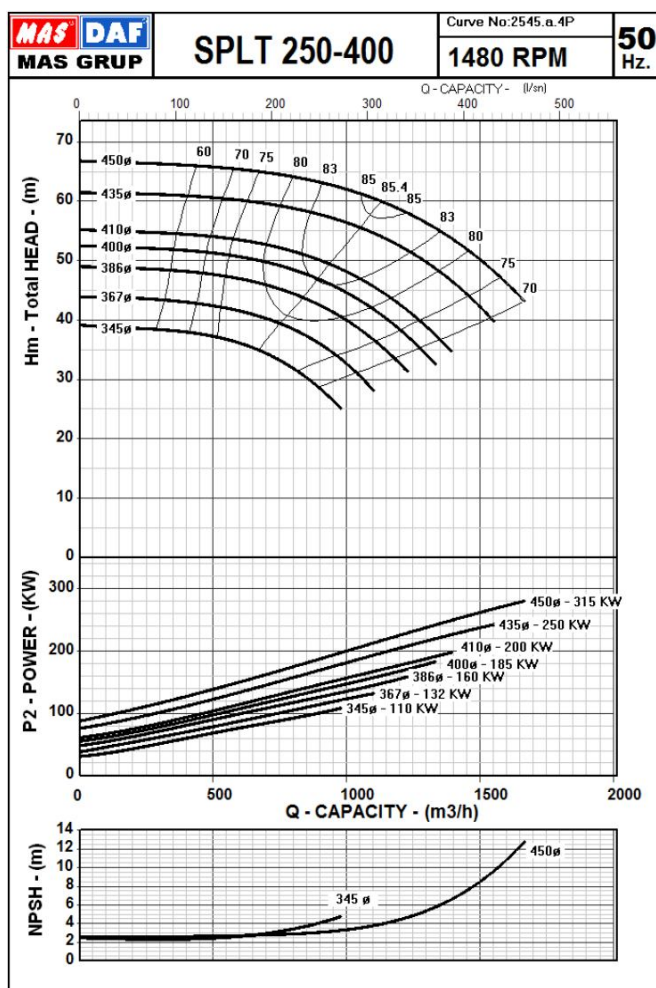
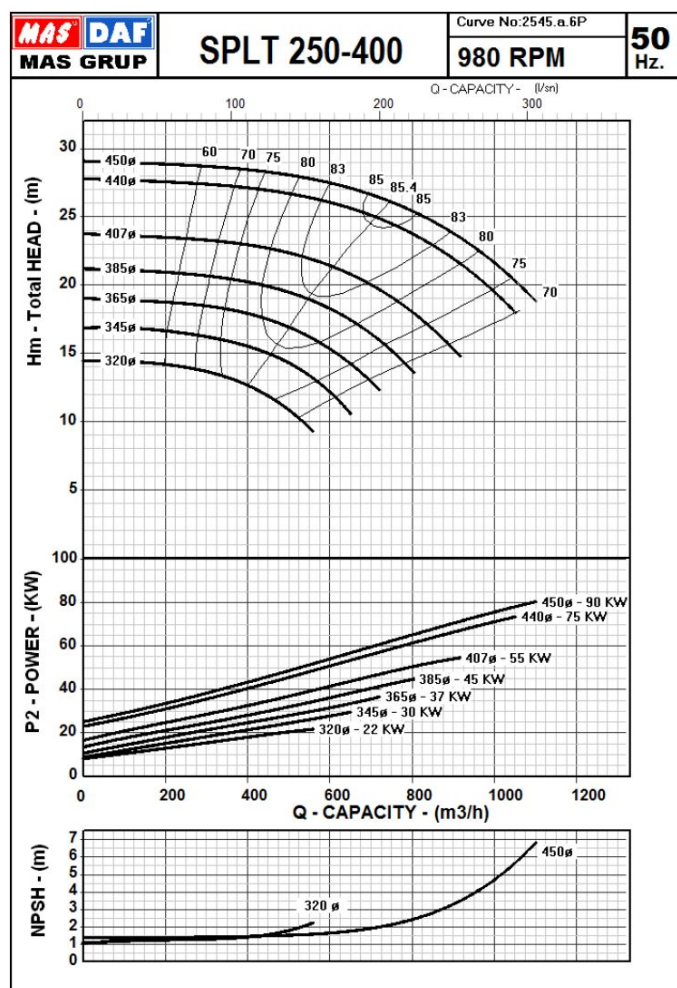



**SPLIT CASE JPLT.M Series**  
Split Case Double Suction Centrifugal Pump  
Performance Range **SPLT 250-500**



**Mas Grup**

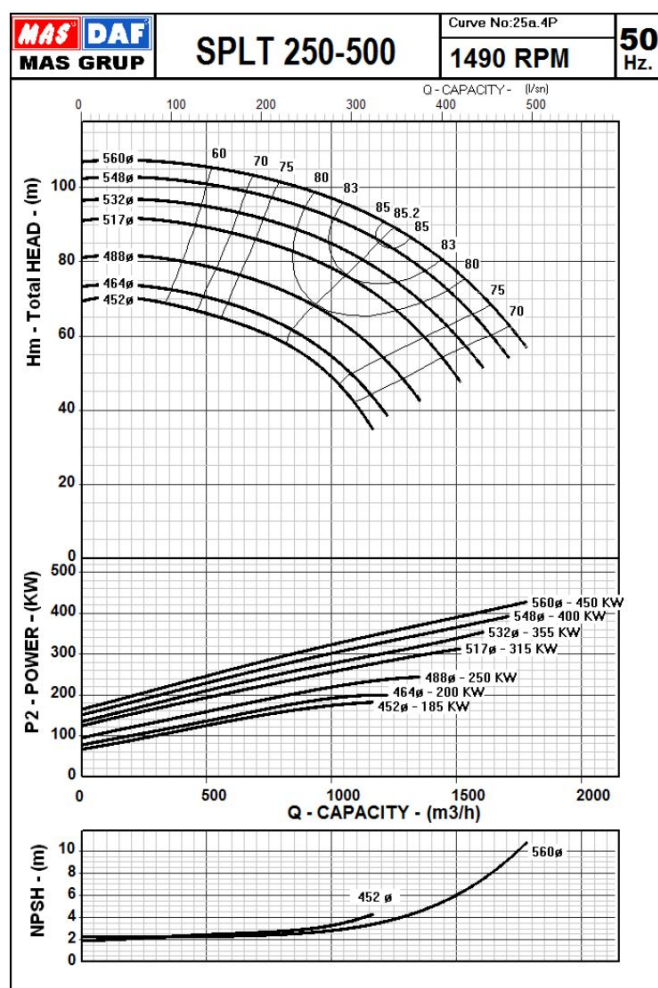
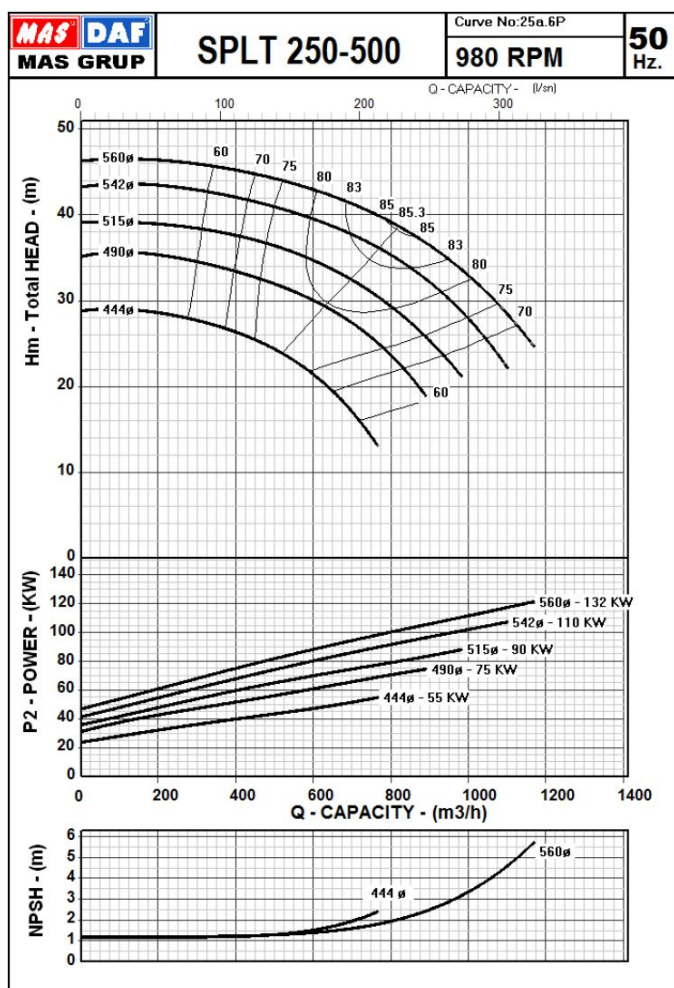

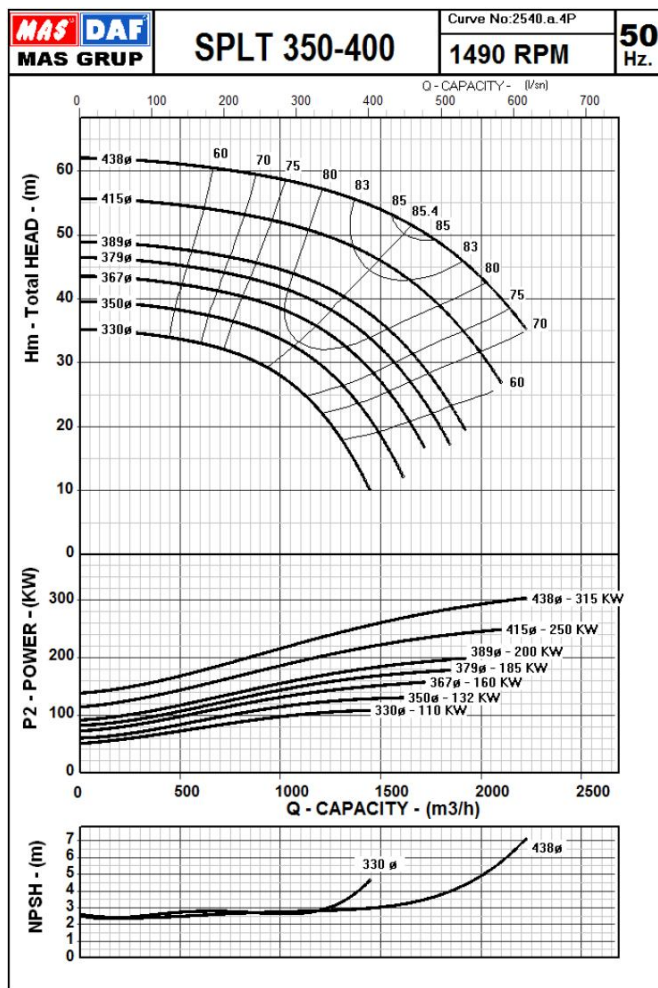
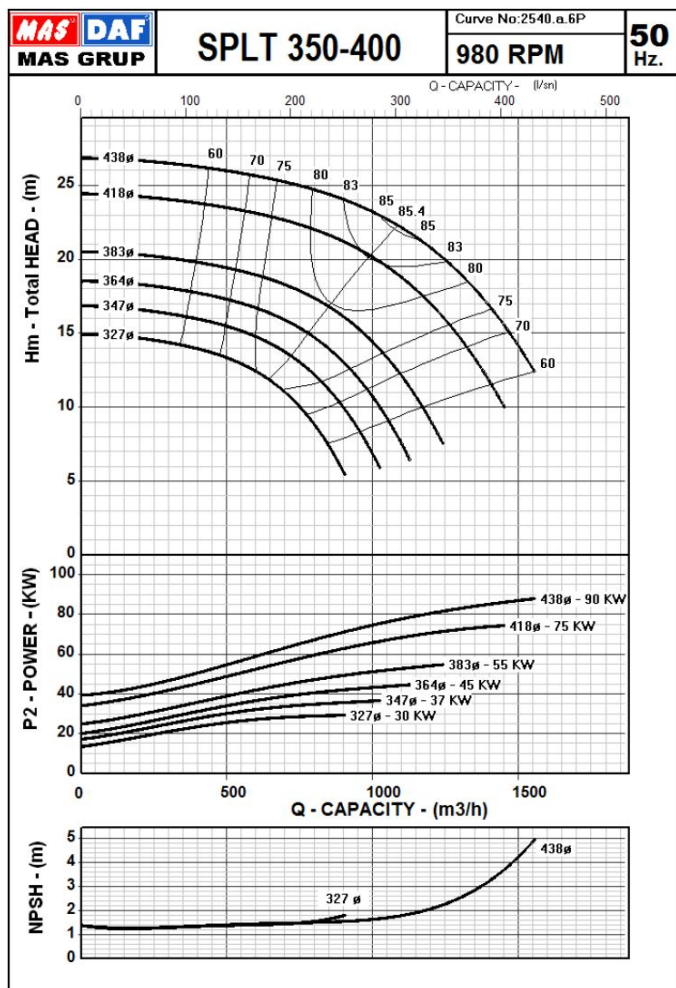

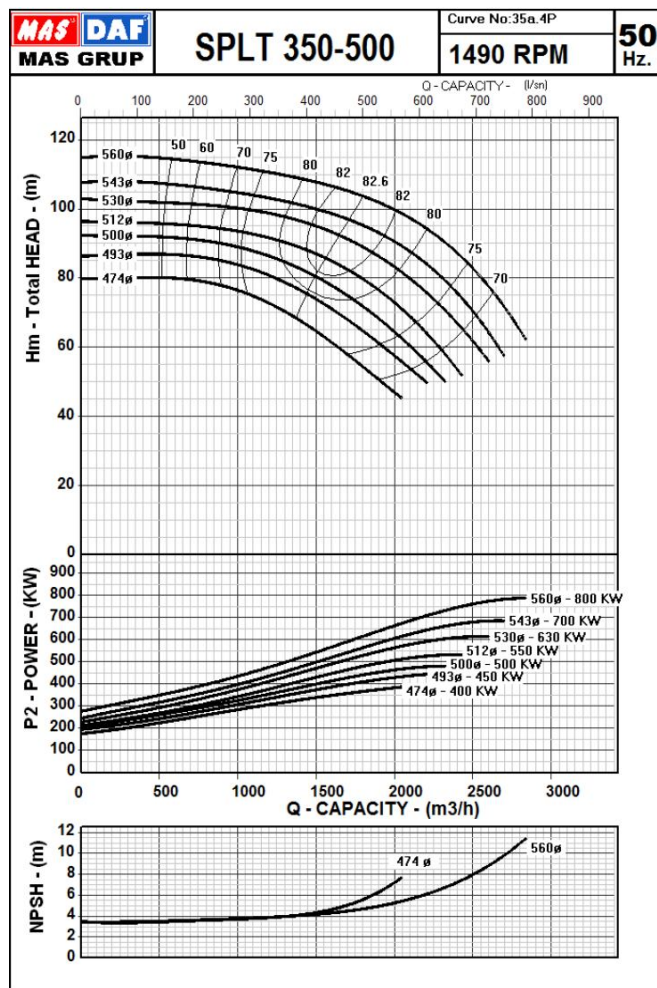
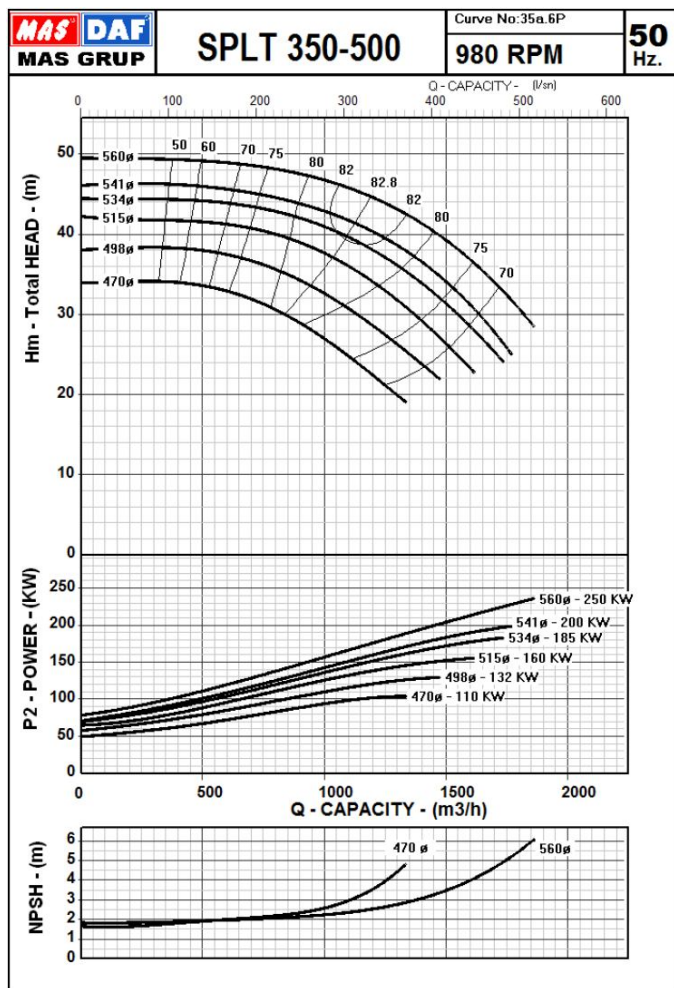

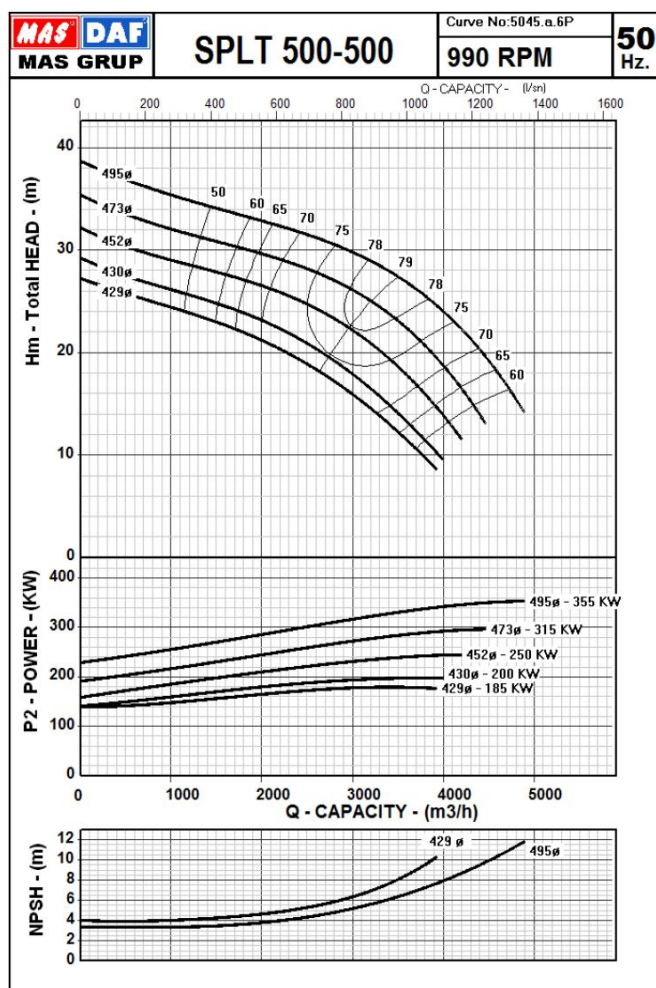
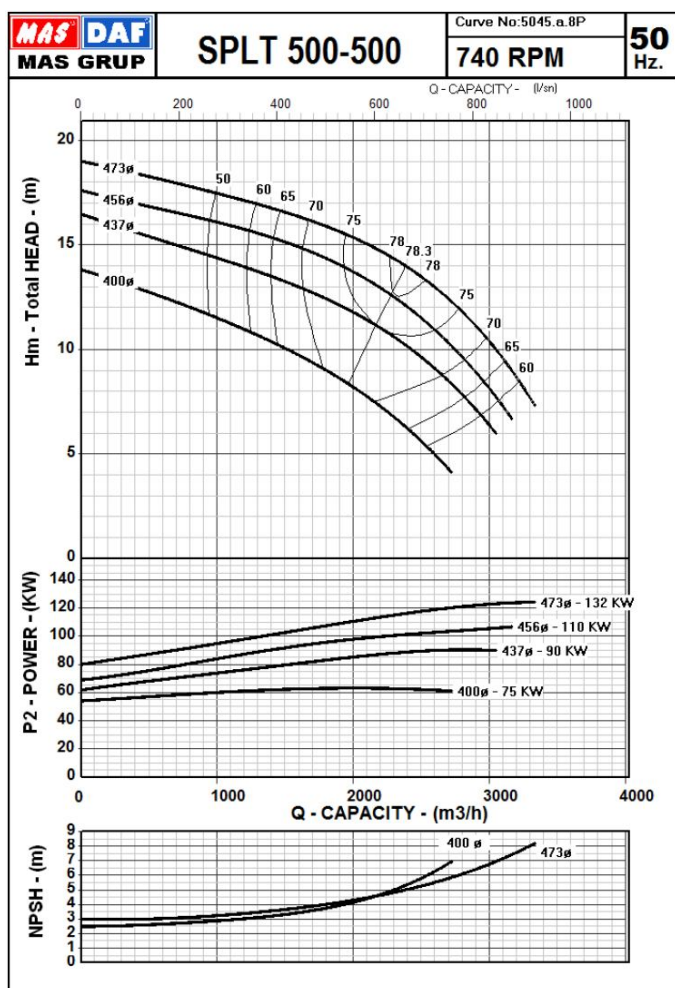

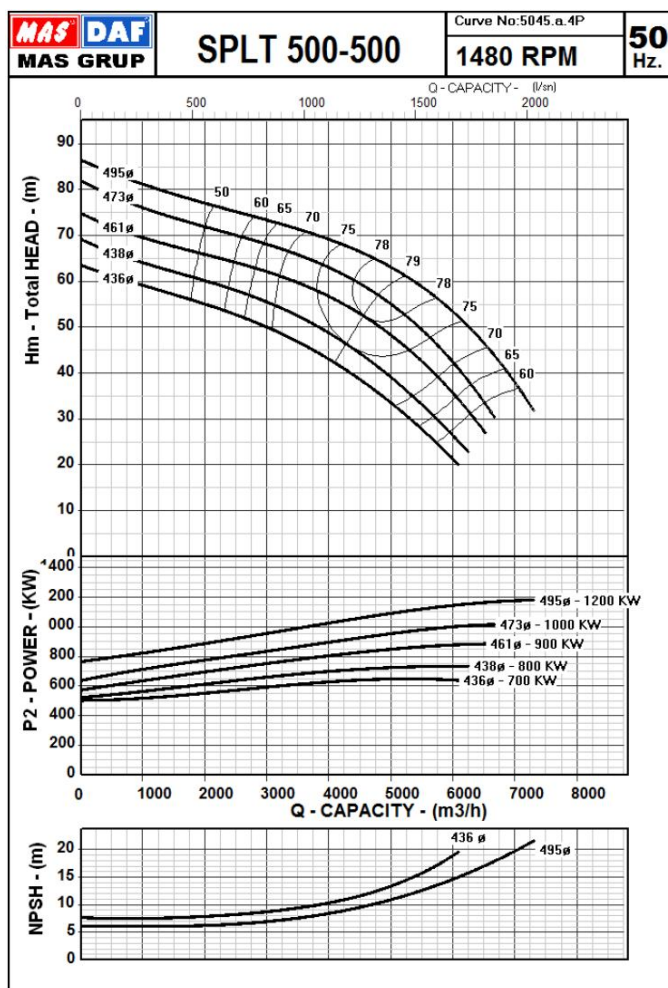

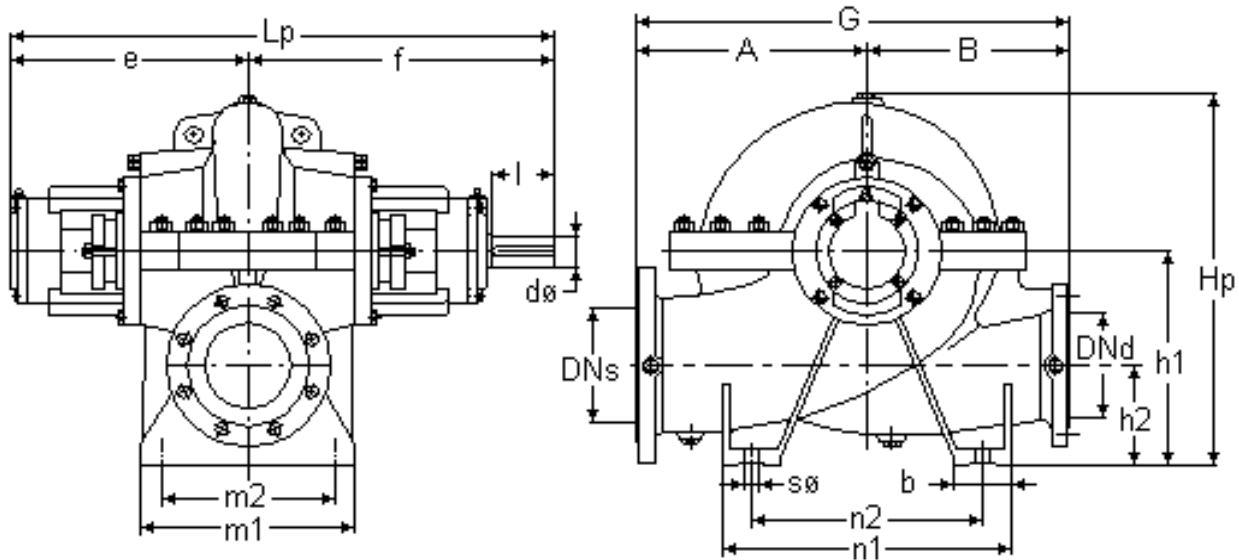

**Dimension of SPTL**

Pump Type	Grup	Flanges		Lp	e	f	h1	h2	Hp	A	B	G	b	m1	m2	n1	n2	Øs	l	Ød
		DNs	DNd																	
65-250	A	100	65	585	260	325	250	115	425	285	225	510	70	240	190	350	275	18	60	28
80-250		125	80	680	300	380	280	140	485	300	275	575	80	234	190	400	330	18	80	35
80-360	B	125	80	680	300	380	315	135	550	325	275	600	80	134	190	400	330	18	80	35
100-250		150	100	715	315	400	315	155	550	325	275	600	80	270	220	400	330	18	80	35
100-315	C	150	100	820	350	470	355	145	585	360	320	680	90	290	230	435	350	23	110	45
150-250		200	150	870	375	495	375	175	635	400	325	725	100	340	270	500	400	23	110	45
125-400	D	150	125	945	415	530	375	175	700	450	400	850	100	370	300	500	400	23	110	55
150-315		200	150	945	415	530	375	175	645	400	350	750	100	370	300	500	400	23	110	55
150-400		200	150	945	415	530	400	200	730	475	400	875	100	370	300	500	400	23	110	55
150-500		200	150	945	415	530	450	250	870	550	500	1050	100	370	300	650	550	23	110	55
200-315		250	200	975	430	545	430	205	730	450	375	825	100	430	360	500	400	23	110	55
200-400		250	200	975	430	545	430	205	790	525	425	950	100	430	360	600	500	23	110	55
200-500	E	250	200	1042	447	595	475	220	870	550	500	1050	100	460	390	650	550	28	140	65
250-315		300	250	1062	457	605	500	225	860	525	450	975	100	480	410	650	550	28	140	65
250-400		300	250	1042	457	595	500	225	865	550	450	1000	100	460	390	650	550	28	140	65
250-500		300	250	1062	457	605	525	240	945	600	500	1100	100	480	410	650	550	28	140	65
350-400	F	400	350	1290	570	720	610	295	1010	600	500	1100	150	600	500	750	600	28	140	75
350-500		400	350	1290	570	720	630	315	1055	650	550	1200	150	600	500	800	650	28	140	75
500-500		500	500	1538	694	844	760	370	1280	750	600	1350	150	700	600	800	650	28	140	75

**Dimension of SPTL.M**

**Note:** SPTL is soft packing design. However, SPTL.M is compact design and only mechanical seal application is possible. All dimensions are in millimeters.

Pump Type	Grup	Flanges		Lp	e	f	h1	h2	Hp	A	B	G	b	m1	m2	n1	n2	Øs	l	Ød
		DNs	DNd																	
65-250	A	100	65	455	195	260	250	115	425	285	225	510	70	240	190	350	275	18	60	28
80-250		125	80	507	212	295	280	140	485	300	275	575	80	234	190	400	330	18	80	32
80-360	B	125	80	507	212	295	315	135	550	325	275	600	80	234	190	400	330	18	80	32
100-250		150	100	545	230	315	315	155	550	325	275	600	80	270	220	400	330	18	80	32
100-315	C	150	100	615	260	355	355	145	585	360	320	680	90	290	230	435	350	23	110	40
150-250		200	150	665	285	380	375	175	635	400	325	725	100	340	270	500	400	23	110	40
125-400	D	150	125	696	300	396	375	175	700	450	400	850	100	370	300	500	400	23	110	50
150-315		200	150	696	300	396	375	175	645	400	350	750	100	370	300	500	400	23	110	50
150-400		200	150	696	300	396	400	200	730	475	400	875	100	370	300	500	400	23	110	50
150-500		200	150	696	300	396	450	250	870	550	500	1050	100	370	300	650	550	23	110	50
200-315		250	200	725	315	410	430	205	730	450	375	825	100	430	360	500	400	23	110	50
200-400		250	200	725	315	410	430	205	790	525	425	950	100	430	360	600	500	23	110	50
200-500	E	250	200	822	337	485	475	220	870	550	500	1050	100	460	390	650	550	28	140	60
250-315		300	250	842	347	495	500	225	860	525	450	975	100	480	410	650	550	28	140	60
250-400		300	250	822	337	485	500	225	865	550	450	1000	100	460	390	650	550	28	140	60
250-500		300	250	842	347	495	525	240	945	600	500	1100	100	480	410	650	550	28	140	60
350-400	F	400	350	1000	435	565	610	295	1010	600	500	1100	150	600	500	750	600	28	140	75

**SPLT & SPLT.M Series**  
Split Case Double Suction Centrifugal Pump  
**SPLT – Exploded View**

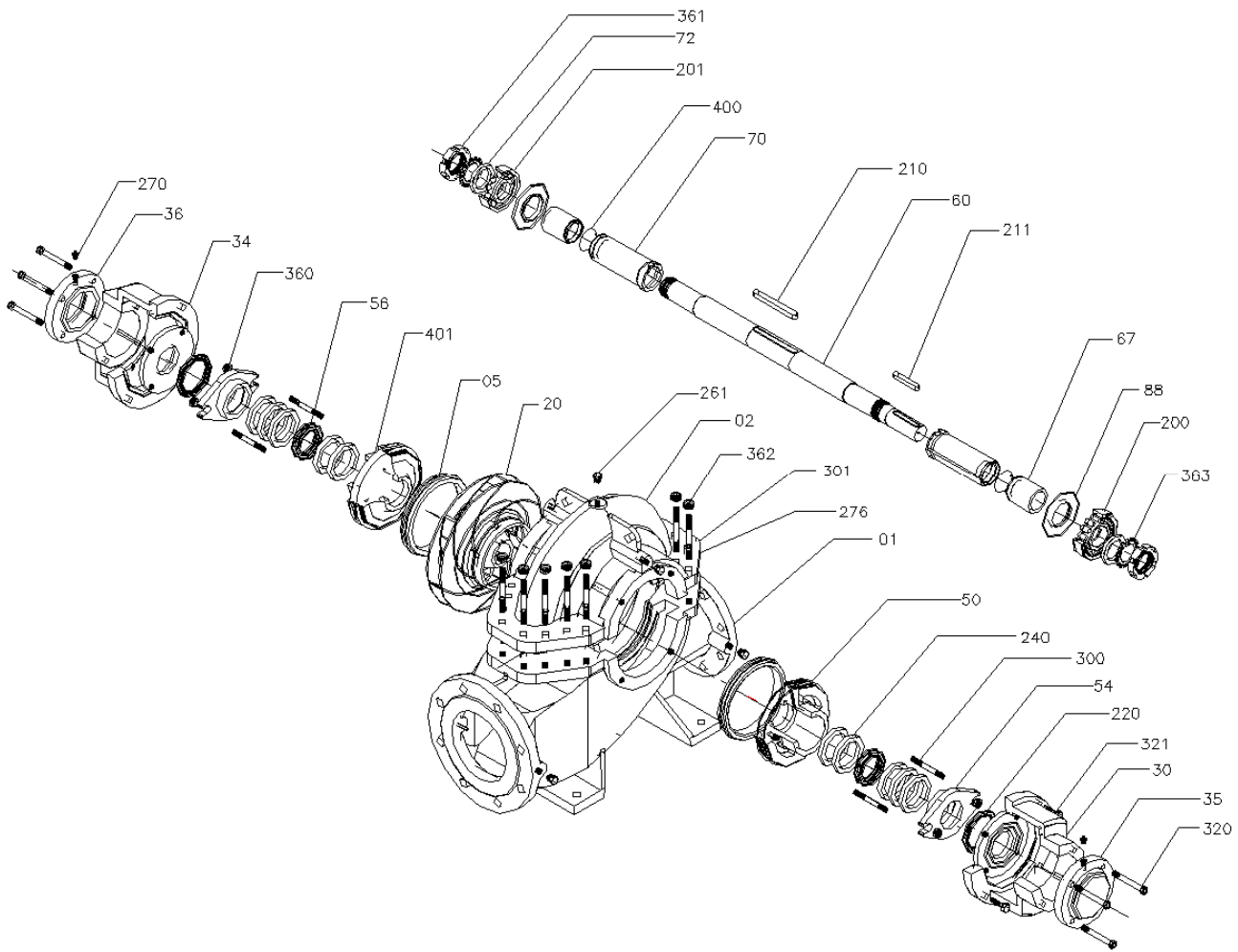

**PART LIST**

PART NO	PART NAME	PART NO	PART NAME
01	Casing Lower Part	201	Roller Bearing
02	Casing Upper Part	210	Key for Impeller
05	Wear Ring	211	Key for Coupling
20	Impeller	220	Oil Seal
30	Bearing Housing	240	Soft Packing
34	Bearing Cover (Dead Side)	260	Plug
35	Bearing Cover (Motor Side)	270	Greaser
36	Bearing Housing Cover	276	Adjusting Tap
50	Stuffing Box	300	Casing Stud
54	Gland	301	Stud for Gland
56	Lantern Ring	320	Hexagonal Bolt
60	Pump Shaft	321	Bolt
70	Seal Sleeve	360	Nut for Casing Stud
72	Ring	361	Nut for Gland
73	Space Sleeve	363	Washer for Bearing
74	Nut for Bearing	400	O-Ring (Stuffing Box)
88	Water Thrower	401	O-Ring (Shaft Sleeve)
200	Ball Bearing		

**SPLT & SPLT.M Series**  
Split Case Double Suction Centrifugal Pump  
**SPLT.M – Exploded View**

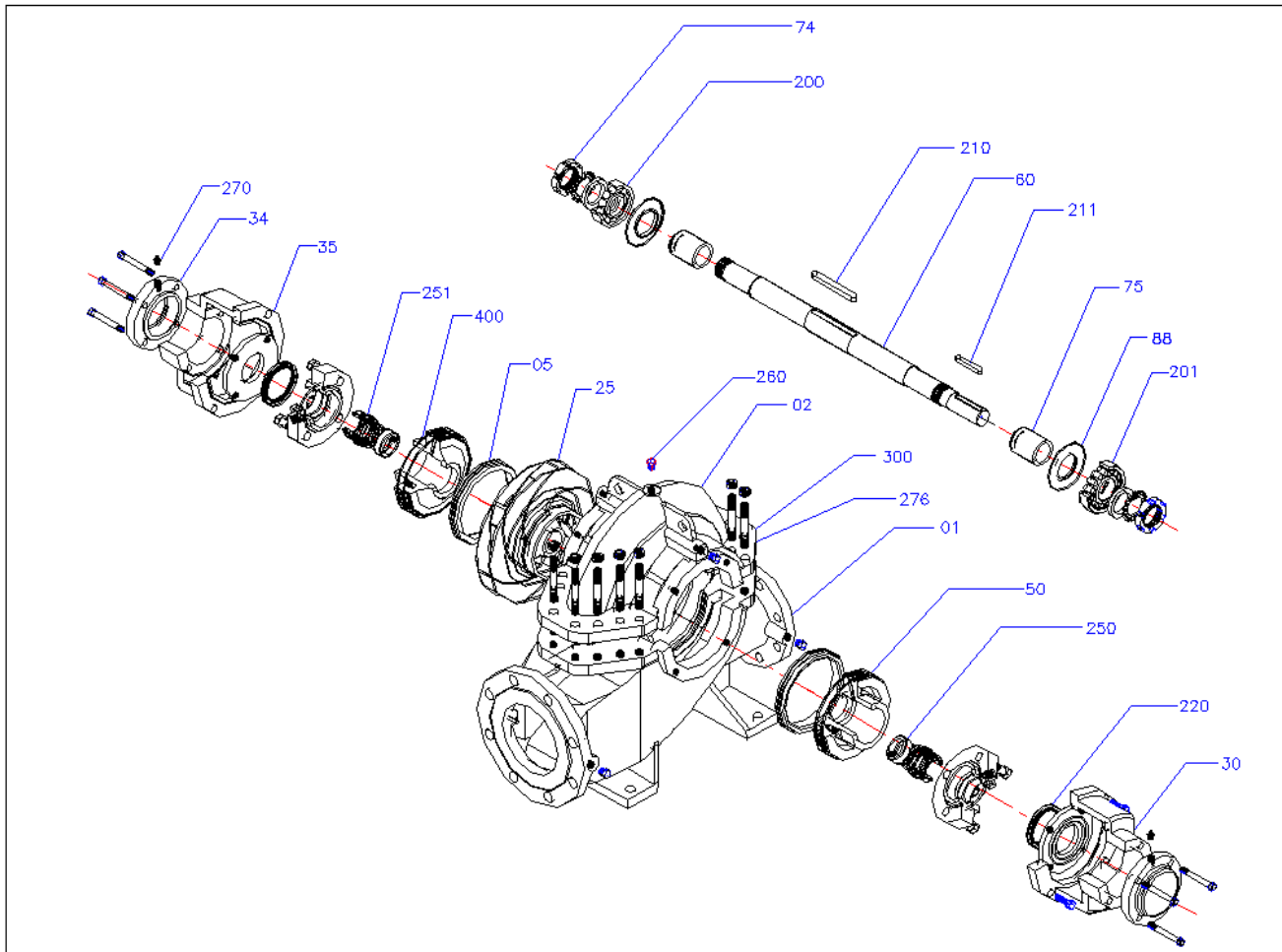

**PART LIST**

PART NO	PART NAME	PART NO	PART NAME
01	Casing Lower Part	200	Ball Bearing
02	Casing Upper Part	201	Roller Bearing
05	Wear Ring	210	Key for Impeller
25	Impeller	211	Key for Coupling
30	Bearing Housing	220	Oil Seal
34	Bearing Housing Cover	250	Mechanical Seal Ring
35	Bearing Cover (Dead Side)	251	Mechanical Seal
50	Stuffing Box	260	Plug
60	Pump Shaft	270	Greaser
74	Nut for Bearing	276	Adjusting Tap
75	Space Sleeve	300	Casing Stud
88	Water Thrower	400	O-Ring (Stuffing Box)





## Mas Grup

### Head Office / Service Center:

Aydınlı Mah. Birlik OSB. 1.No'lu Cadde No:17 Tuzla - İSTANBUL / TURKEY  
Tel: +90 (216) 456 47 00 pbx Fax: +90 (216) 455 14 24

### Ankara Regional Directorate:

Aşağı Öveçler Mah. 1329 Sok. No:6/9 Öveçler ANKARA / TURKEY  
Tel: +90 (312) 472 81 60-67 Fax: +90 (312) 472 82 51

### Factory:

1. Organize Sanayi Bölgesi Parsel 249/5 Beyköy - DÜZCE / TURKEY  
Tel: +90 (380) 553 73 88 Fax: +90 (380) 553 71 29

---

[www.masgrup.com](http://www.masgrup.com) [info@masgrup.com](mailto:info@masgrup.com)