

APPLICAZIONI

Elettropompe centrifughe monoblocco con girante in ghisa. Queste macchine sono adatte per il pompaggio di acqua pulita e di altri liquidi chimicamente e meccanicamente non aggressivi. Adatte per le più svariate esigenze in campo civile, agricolo, industriale o impiantistico in generale. Approvvigionamenti d'acqua, irrigazioni a pioggia o a scorrimento, alimentazioni autoclavi e sopraelevazioni di pressione e in qualsiasi altro impiego che comporta il travaso di liquidi puliti in genere.

APPLICATION

Centrifugal monoblock with cast iron impeller. These machines are ideal for pumping clean water and other chemically and mechanically non-aggressive liquids. Used for a wide variety of applications in civil, agricultural, industrial or general plant uses. Water supply, spray or flowing irrigation, autoclave feed, high pressure system and any other general service requiring transfer of clean liquids.

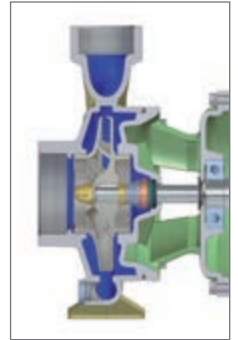

LIMITI D'IMPIEGO

- Temperatura liquido fino a 35°C (per un uso domestico secondo EN 60335-2-41)
- Temperatura max. liquido: 90°C (per altri impieghi)
- Temperatura ambiente fino a 40° C
- Altezza d'aspirazione manometrica fino a 7 mt.
- Servizio continuo

OPERATING CONDITIONS

- Liquid temperature up to 35°C (for home use according to EN 60335-2-41)
- Temperature max. liquid: 90°C (for other uses)
- Ambient temperature up to 40°C
- Total suction lift up to 7 mt.
- Continuous duty

MOTORE

- Monofase 230V-50Hz
- Trifase 230/400V-50Hz
- Motore elettrico ad induzione a 2 poli (n = 2850 min⁻¹)
- Isolamento Classe F
- Protezione IP 55

MOTOR

- Single-phase 230V-50Hz
- Three-phase 230/400V-50Hz
- Two-Pole induction motor (n = 2850 min⁻¹)
- Insulation Class F
- Protection IP 55

MATERIALI

- Corpo pompa Ghisa
- Supporto motore Ghisa
- Girante Ghisa
- Albero motore Acciaio Inox AISI 304
- Tenute meccaniche Ceramica/Grafite/NBR

MATERIALS

- Pump body Cast Iron
- Motor Support Cast Iron
- Impeller Cast Iron
- Shaft with rotor Stainless Steel AISI 304
- Mechanical seal Ceramic/Graphite/NBR

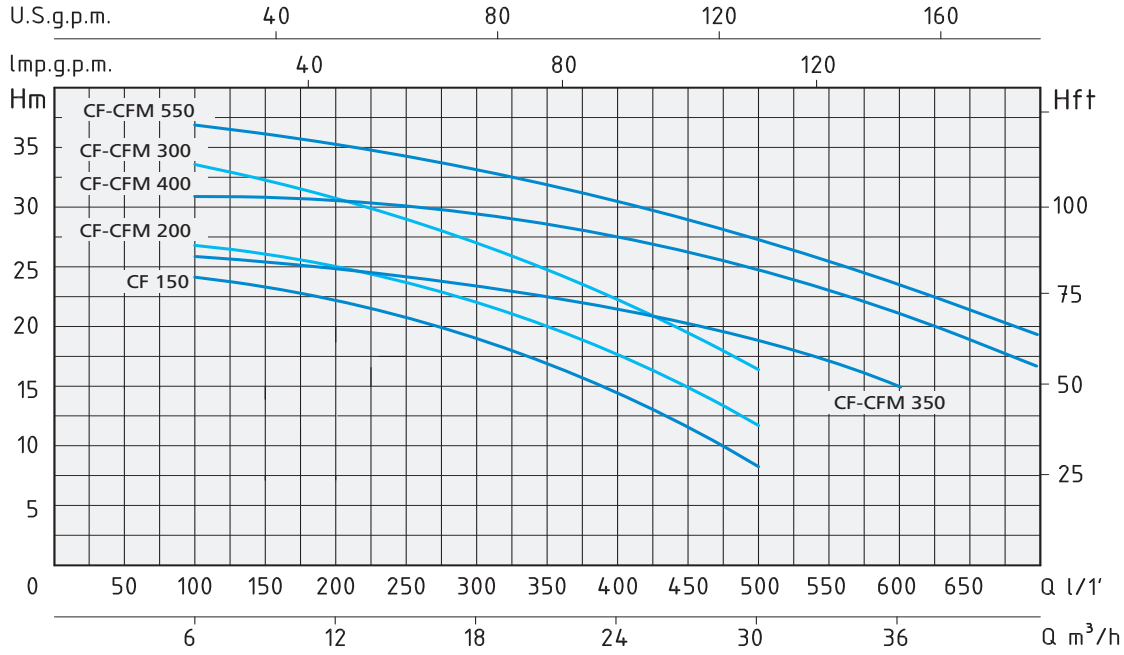

TIPO TYPE		POTENZA NOMINALE NOMINAL POWER		POTENZA ASSORBITA INPUT POWER	AMPERE		Q = PORTATA - CAPACITY										
Monofase Single-phase	Trifase Three-phase	P2		P1	Monofase Single-phase	Trifase Three-phase	m³/h	6	9	12	18	21	24	27	30	36	42
		HP	KW	KW			100	150	200	300	350	400	450	500	600	700	
	CF 150	1,5	1,1	2,25		4,3	Prevalenza manometrica totale in m.C.A. - Total head in meters w.c.										
CFM 200	CF 200	2	1,5	2,7	12	5,1	24	23	21,5	18,5	16,5	14,5	11,5	8,5			
CFM 300	CF 300	3	2,2	3,6	16	5,9	27	26	25	21	19	17	14,5	12			
CFM 350	CF 350	3	2,2	3,6	16	5,9	33,5	32,5	30,5	27	25	22,5	19,5	16,5			
CFM 400	CF 400	4	3	4,5	20	7,3	26	25,5	25	23,5	22,5	21,5	20,5	19	15		
CFM 550	CF 550	5,5	4	5,7	28	9,3	31,5	31,2	31	29,5	28,5	27,5	26	24,5	20,5	16,5	
							37	36	35,5	33,5	32	30,5	29	27,5	24	19	

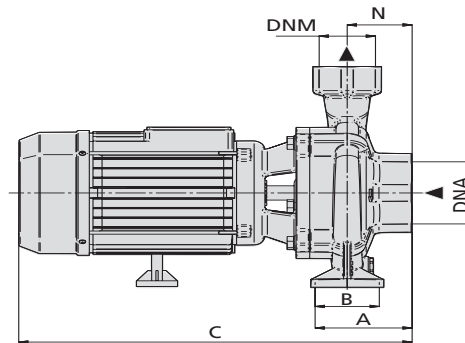
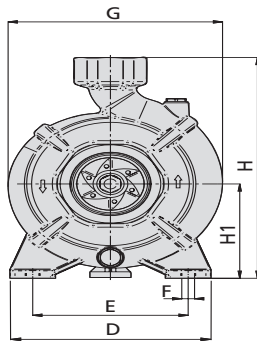

TIPO TYPE		DIMENSIONI mm - DIMENSIONS mm											DIMENSIONI DIMENSIONS mm			PESO WEIGHT	
Monofase Single-phase	Trifase Three-phase	A	B	C	D	E	F	G	H	H1	N	DNA	DNM	P	L	H	Kg
			CF 150	96	55	394	210	165	14	220	286	119	68,5	2"	2"	259	507
CFM 200	CF 200	96	55	394	210	165	14	220	286	119	68,5	2"	2"	259	507	345	27,6
CFM 300	CF 300	96	55	430	210	165	14	220	286	119	68,5	2"	2"	259	507	345	30,7
CFM 350	CF 350	98,5	55	430	220	170	14	237,5	309	132	71	3"	2"	282	490	365	31,6
CFM 400	CF 400	98,5	55	496	220	170	14	237,5	309	132	71	3"	2"	269	540	421	43,3
CFM 550	CF 550	98,5	55	496	220	170	14	237,5	309	132	71	3"	2"	269	540	421	46,6