

Application

- It is applicable to household water supply, equipment support, pipeline pressurization, garden watering, vegetable greenhouse watering, fish farming and poultry raising, industrial and mining, water supply and drainage of enterprises and high-rise buildings, central air conditioner and centralized heating circulation system, etc

Pump

- AISI304 welding shaft
- Max. liquid temperature: +60°C
- Altitude: up to 1000 m
- Max. inlet pressure: limited by Max. operating pressure
- Max. operation pressure: 8 bar
- Liquid PH Value: 6.5 - 8.5

Motor

- IE2 motor
- Motor with copper winding
- Built-in thermal protector for single phase motor
- Insulation class: F
- Protection class: IPX4
- Max. ambient temperature: +40°C

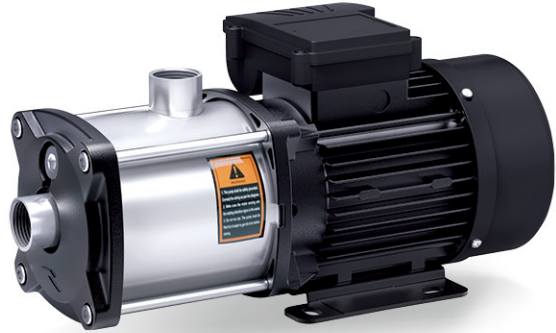

Identification Codes

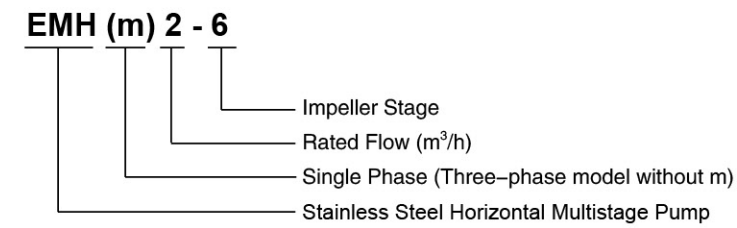

Hydraulic Performance Curves

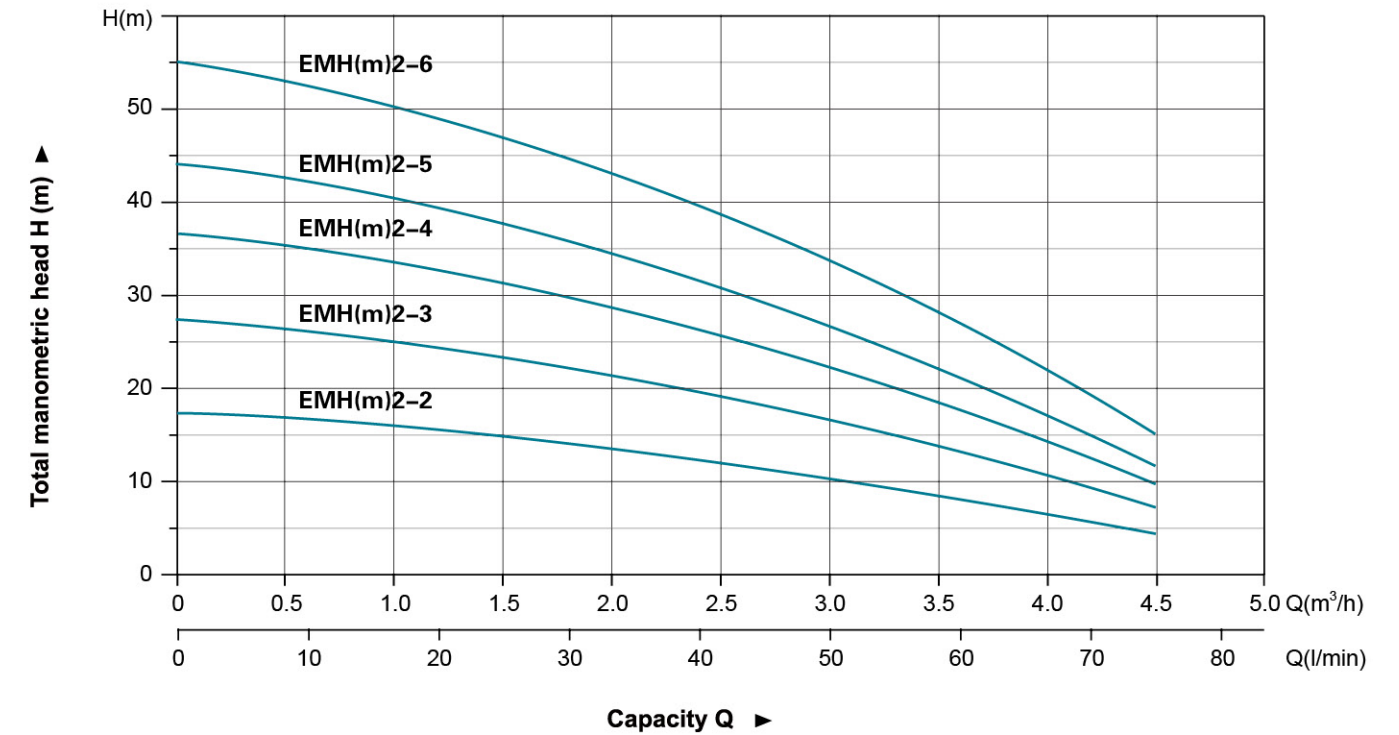

Technical Data

Model	Power		Q (m³/h) Q (l/min)	0	1	1.5	2	2.5	3	3.5	4	4.5
	kW	HP		0	16.7	25	33.3	41.7	50	58.3	66.7	75
EMH(m)2-2	0.25	0.33	H (m)	17	16	14.5	13.5	12	10.5	8.5	7	4.5
EMH(m)2-3	0.37	0.5		27	24.5	23	20.5	19	17	14	11	7
EMH(m)2-4	0.37	0.5		36	33	31	27.5	25.5	22.5	19	14.5	9.5
EMH(m)2-5	0.55	0.75		44	40	37	33.5	30.5	27	22.5	17	11
EMH(m)2-6	0.75	1.0		54	49.5	46	41.5	38.5	34	29	21.5	15

Materials Table

No.	Part	Material
1	Pump cover	ADC 12
2	Pump body	AISI 304
3	Diffuser 1	AISI 304
4	Base	Q235 Steel
5	Diffuser 2	AISI 304
6	Impeller	AISI 304
7	Sleeve	AISI 304
8	Diffuser 3	AISI 304
9	Mechanical seal	SIC/Carbon
10	O-Ring	NBR
11	Bracket cover	AISI 304
12	Bracket	ADC 12
13	Rotor	
14	Terminal Box	
15	Stator	
16	Bearing	
17	Rear cover	ADC 12
18	Fan	PP
19	Fan cover	PP

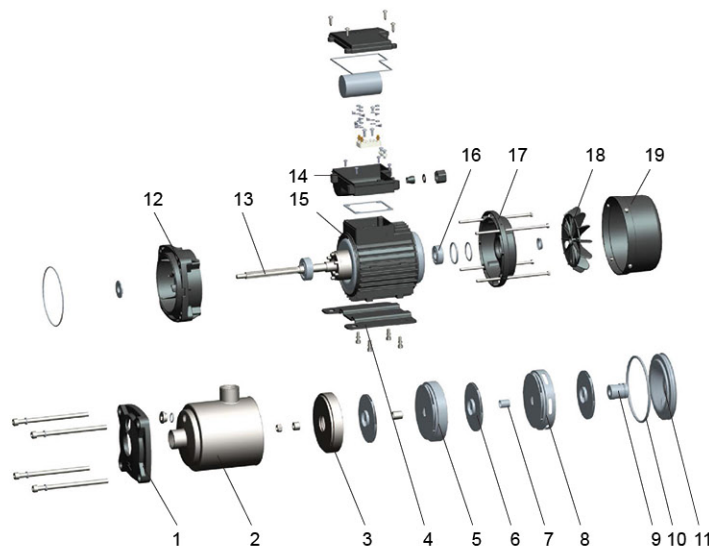

Dimension

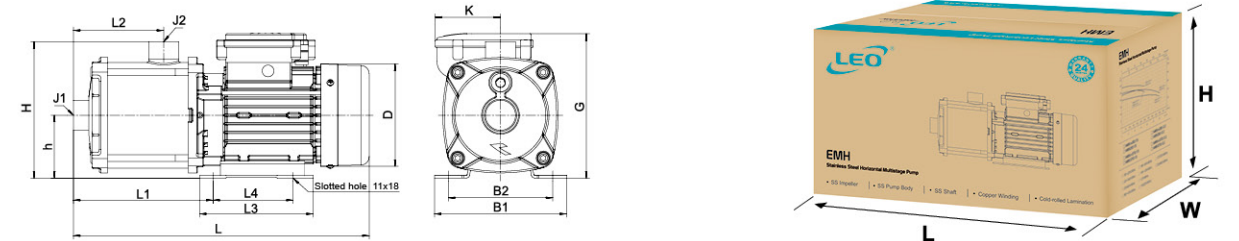

Model	L	L1	L2	L3	L4	H	h	B1	B2	D	G		K	J1/J2	GW(Kgs)		L x W x H (mm)	Quantity (PCS/20 TEU)
											1~ / 3~	1~ / 3~			1~	3~		
EMH(m)2-2	305	131	72	136	96	163	75	158	125	122	163/172.5	-/78	G1/G1	7.6	7.2	344x189x232	1638	
EMH(m)2-3	305	131	72	136	96	163	75	158	125	122	163/172.5	-/78	G1/G1	8.3	7.6	344x189x232	1638	
EMH(m)2-4	323	149	90	136	96	163	75	158	125	122	163/172.5	-/78	G1/G1	9.7	7.7	362x189x232	1530	
EMH(m)2-5	354	167	108	136	96	163	75	158	125	122	163/172.5	-/78	G1/G1	10.3	8.8	392x189x232	1458	
EMH(m)2-6	382	185	126	136	96	163	75	158	125	146.5	172/182.5	-/89	G1/G1	12.4	11.4	420x214x247	1064	

Hydraulic Performance Curves

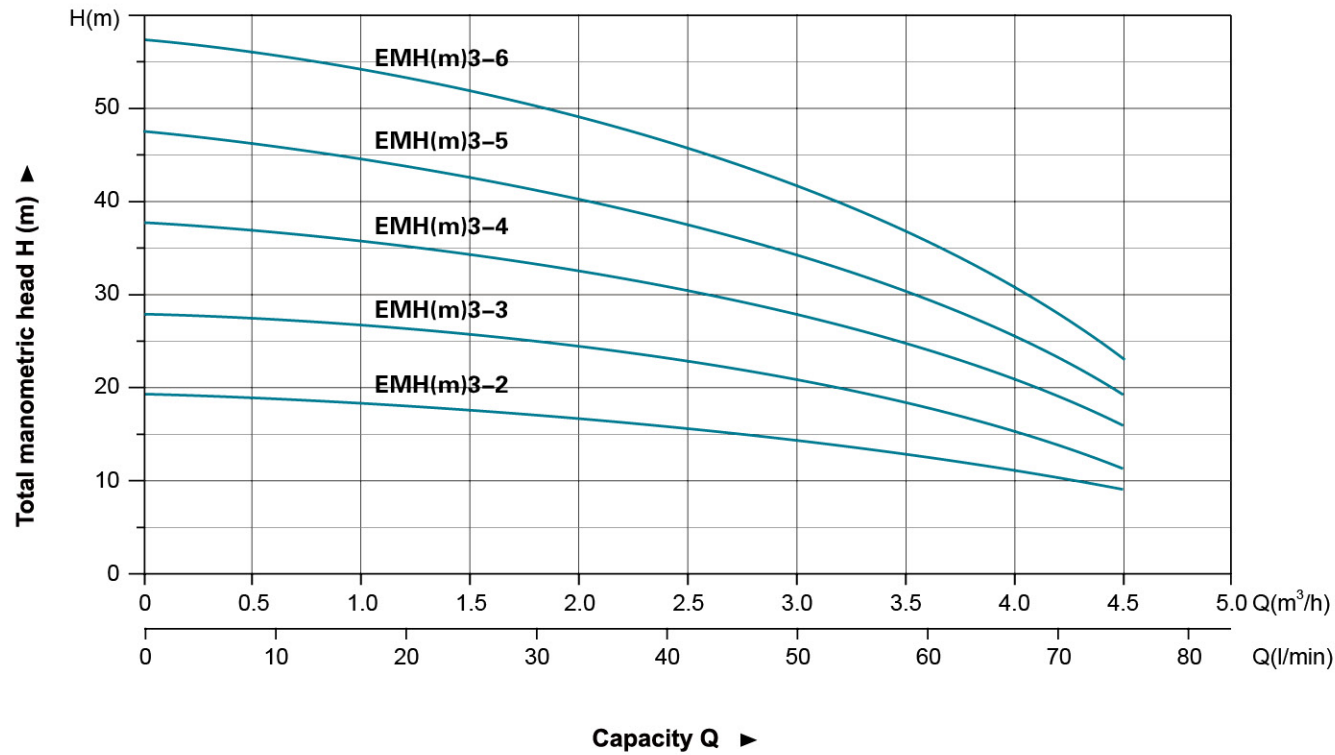

Hydraulic Performance Curves

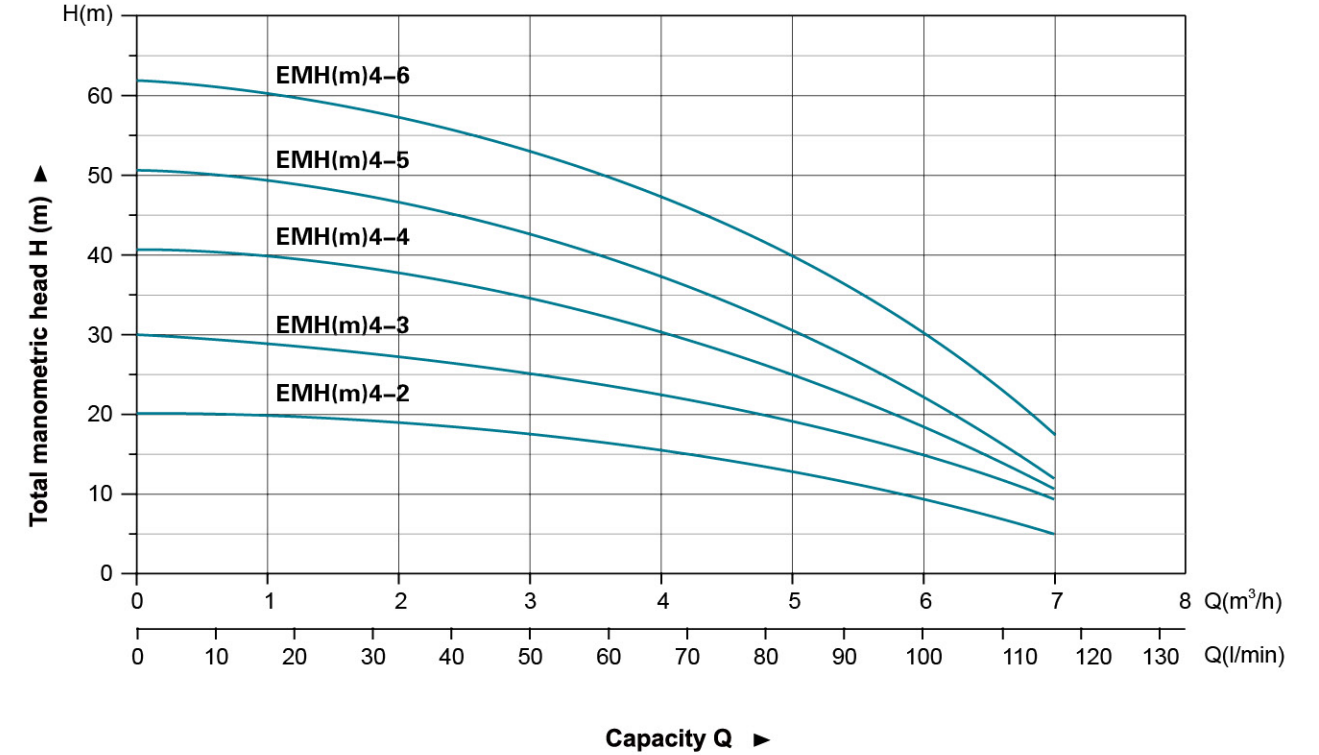

Technical Data

Model	Power		Q (m³/h)	Q (l/min)										
	kW	HP		0	0.5	1	1.5	2	2.5	3	3.5	4	4.5	
EMH(m)3-2	0.25	0.3	19.5	18.5	18	17.5	16.5	15	14.5	13	11	9		
EMH(m)3-3	0.37	0.5	29	27.5	26	25.5	24.5	23	21	18	16	12		
EMH(m)3-4	0.55	0.75	38	36.5	35.5	34	32	30.5	28	25	21	16		
EMH(m)3-5	0.55	0.75	47.5	46	44.5	42.5	40	37.5	34	29	24	19		
EMH(m)3-6	0.75	1.0	57.5	55.5	53.5	52	49	45	42	35	29	23		

Technical Data

Model	Power		Q (m³/h)	Q (l/min)										
	kW	HP		0	1	2	3	4	4.5	5	6	7		
EMH(m)4-2	0.37	0.5	20	19.5	18.5	17	15.5	14.5	13	9.5	5			
EMH(m)4-3	0.55	0.75	30	29	27.4	25	22.5	21	18.5	13	10			
EMH(m)4-4	0.75	1.0	40	38.5	36.5	34.5	30.5	29	26	19	10			
EMH(m)4-5	0.75	1.0	50	47.5	45.5	42.5	37.5	35.5	32	23	12			
EMH(m)4-6	1.1	1.5	61.5	59	56	53	47.5	45	41	30.5	17			

Dimension

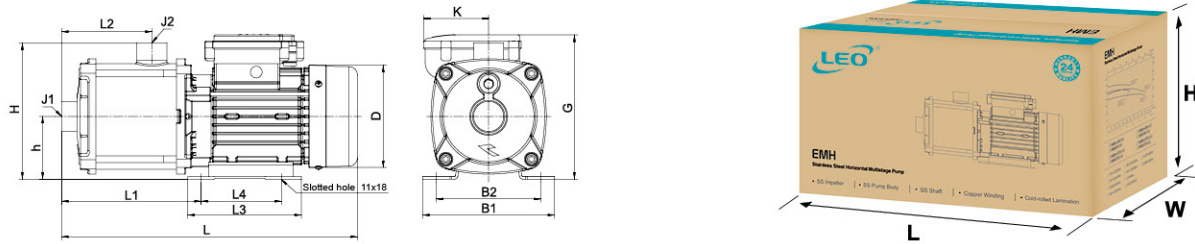

Model	L	L1	L2	L3	L4	H	h	B1	B2	D	G		K	J1/J2	GW(Kgs)		L x W x H (mm)	Quantity (PCS/20' TEU)
											1~ / 3~	1~ / 3~			1~	3~		
EMH(m)3-2	305	131	72	136	96	163	75	158	125	122	163/172.5	-78	G1/G1	7.5	6.9	344×189×232	1638	
EMH(m)3-3	305	131	72	136	96	163	75	158	125	122	163/172.5	-78	G1/G1	7.9	7.9	344×189×232	1638	
EMH(m)3-4	336	149	90	136	96	163	75	158	125	122	163/172.5	-78	G1/G1	9.1	8.5	374×189×232	1485	
EMH(m)3-5	354	167	108	136	96	163	75	158	125	122	163/172.5	-78	G1/G1	10.4	9.3	392×189×232	1458	
EMH(m)3-6	382	185	126	136	96	163	75	158	125	146.5	172/182.5	-89	G1/G1	11.7	11.3	420×214×247	1064	

Dimension

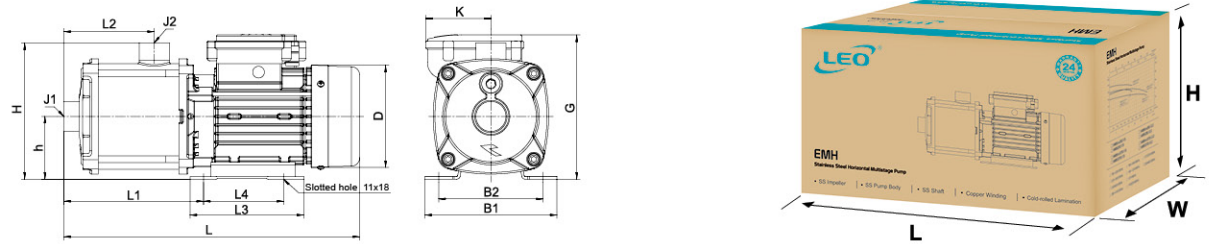

Model	L	L1	L2	L3	L4	H	h	B1	B2	D	G		K	J1/J2	GW(Kgs)		L x W x H (mm)	Quantity (PCS/20' TEU)
											1~ / 3~	1~ / 3~			1~	3~		
EMH(m)4-2	308.5	134	75	136	96	163	75	158	125	122	163/172.5	-78	G1¼/G1	8	7.5	344×189×232	1638	
EMH(m)4-3	321	134	75	136	96	163	75	158	125	122	163/172.5	-78	G1¼/G1	8.7	8	357×189×232	1530	
EMH(m)4-4	349	152	93	136	96	163	75	158	125	146.5	172/182.5	-89	G1¼/G1	11	9.9	384×214×247	1136	
EMH(m)4-5	367	170	111	136	96	163	75	158	125	146.5	172/182.5	-89	G1¼/G1	12.2	10.8	402×214×247	1104	
EMH(m)4-6	411	188	129	155	125	178	90	178	140	167	203/212	-105.5	G1¼/G1	16.5	13.1	446×244×272	864	