

APPLICAZIONI

Elettropompe sommerse multistadio per pozzi profondi da 4" (DN 100 mm). Particolarmente adatte per applicazioni civili e industriali, alimentazione getti d'acqua e fontane, impianti antincendio, l'irrigazione in generale e per l'approvvigionamento di acqua pulita.

APPLICATION

Multistage submersible water pumps for 4" deep wells (DN 100 mm). Particularly suitable for civil and industrial purposes, for sprinkler and food irrigation plants, in fire installations and generally speaking for clean water supplying.

LIMITI D'IMPIEGO

- Profondità max. di immersione 150 mt
- Temperatura liquido fino a 35°C (per un uso domestico secondo EN 60335-2-41)
- Temperatura max. liquido: 35°C (per altri impieghi)
- Contenuto di sabbia max. 50 g/m³
- Partenza /ora 20 max.

MOTORE

- Motore elettrico ad induzione a 2 poli (n=2850 min⁻¹)
- Motore sommerso in bagno d'olio
- Isolamento Classe F
- Protezione IP 68
- Servizio continuo

MATERIALI MOTORE

- Camicia esterna Acciaio inox AISI 304
- Albero motore Acciaio inox AISI 304
- Supporto superiore Ghisa zincata
- Tenuta meccanica Ceramica/Grafite

MATERIALI POMPE

- Camicia esterna Acciaio inox AISI 304
- Albero motore Acciaio inox AISI 304
- Stadi e giranti Acciaio inox AISI 304

OPERATING CONDITIONS

- Max. depth of immersion 150 mt
- Liquid temperature up to 35°C (for home use according to EN 60335-2-41)
- Temperature max. liquid: 35°C (for other uses)
- Sand content max. 50 g/m³
- Start/hour 20 max.

MOTOR

- Two-pole induction motor (n=2850 min⁻¹)
- Submersible motor in oil bath
- Class F Insulation
- IP 68 Protection
- Continuous duty

MOTOR MATERIALS

- External casing Stainless steel AISI 304
- Motor shaft Stainless steel AISI 304
- Upper bracket Zinc plated Cast Iron
- Mechanical seal Ceramic/Graphite

PUMP MATERIALS

- External casing Stainless steel AISI 304
- Motor shaft Stainless steel AISI 304
- Stages and impellers Stainless steel AISI 304

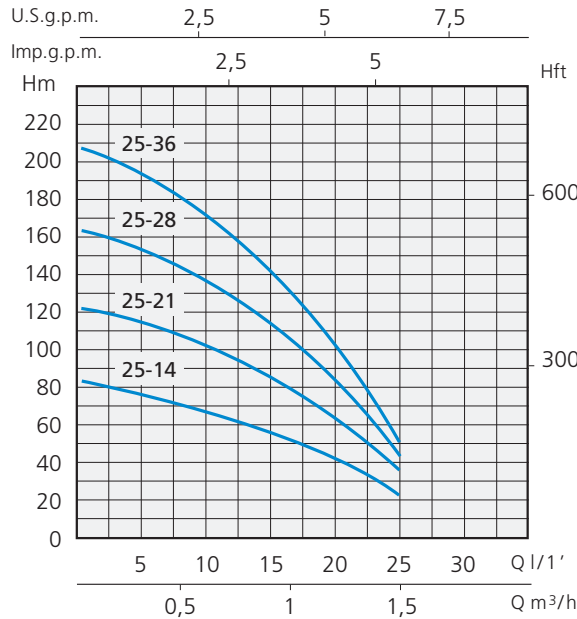

TIPO TYPE	DIMENSIONI mm - DIMENSIONS mm		
	A	B	C
SXM-SXT 25-14	346	461	807
SXM-SXT 25-21	365	608	973
SXM-SXT 25-28	380	755	1135
SXM-SXT 25-36	405	946	1351

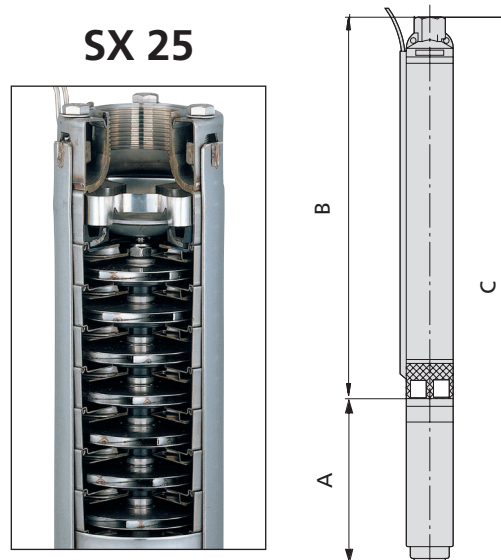

TIPO - TYPE		POTENZA NOMINALE NOMINAL POWER		STADI STAGES	Q = PORTATA - CAPACITY						DNM	
Monofase Single-phase	Trifase Three-phase	P2			m ³ /h	0	0,3	0,6	0,9	1,2		1,5
230V-50Hz	400V-50Hz	HP	kW		lt/1'	0	5	10	15	20	25	
					Prevalenza manometrica totale in m.C.A. - Total head in meters w.c.							
SXM 25-14	SXT 25-14	0,5	0,37	14	H (m)	82	76	70	56	41	21	1" 1/4
SXM 25-21	SXT 25-21	0,75	0,55	21		121	112	101	81	58	36	1" 1/4
SXM 25-28	SXT 25-28	1	0,75	28		162	153	138	111	73	42	1" 1/4
SXM 25-36	SXT 25-36	1,5	1,1	36		207	195	171	139	93	50	1" 1/4

INOX MULTISTAGE SUBMERSIBLE PUMPS FOR 4" WELLS



APPLICAZIONI

Elettropompe sommerse multistadio per pozzi profondi da 4" (DN 100 mm). Particolarmente adatte per applicazioni civili e industriali, alimentazione getti d'acqua e fontane, impianti antincendio, l'irrigazione in generale e per l'approvvigionamento di acqua pulita.

APPLICATION

Multistage submersible water pumps for 4" deep wells (DN 100 mm). Particularly suitable for civil and industrial purposes, for sprinkler and food irrigation plants, in fire installations and generally speaking for clean water supplying.

LIMITI D'IMPIEGO

- Profondità max. di immersione 150 mt
- Temperatura liquido fino a 35°C (per un uso domestico secondo EN 60335-2-41)
- Temperatura max. liquido: 35°C (per altri impieghi)
- Contenuto di sabbia max. 50 g/m³
- Partenza /ora 20 max.

MOTORE

- Motore elettrico ad induzione a 2 poli (n=2850 min⁻¹)
- Motore sommerso in bagno d'olio
- Isolamento Classe F
- Protezione IP 68
- Servizio continuo

MATERIALI MOTORE

- Camicia esterna: Acciaio inox AISI 304
- Albero motore: Acciaio inox AISI 304
- Supporto superiore: Ghisa zincata
- Tenuta meccanica: Ceramica/Grafite

MATERIALI POMPE

- Camicia esterna: Acciaio inox AISI 304
- Albero motore: Acciaio inox AISI 304
- Stadi e giranti: Acciaio inox AISI 304

OPERATING CONDITIONS

- Max. depth of immersion 150 mt
- Liquid temperature up to 35°C (for home use according to EN 60335-2-41)
- Temperature max. liquid: 35°C (for other uses)
- Sand content max. 50 g/m³
- Start/hour 20 max.

MOTOR

- Two-pole induction motor (n=2850 min⁻¹)
- Submersible motor in oil bath
- Class F Insulation
- IP 68 Protection
- Continuous duty

MOTOR MATERIALS

- External casing: Stainless steel AISI 304
- Motor shaft: Stainless steel AISI 304
- Upper bracket: Zinc plated Cast Iron
- Mechanical seal: Ceramic/Graphite

PUMP MATERIALS

- External casing: Stainless steel AISI 304
- Motor shaft: Stainless steel AISI 304
- Stages and impellers: Stainless steel AISI 304

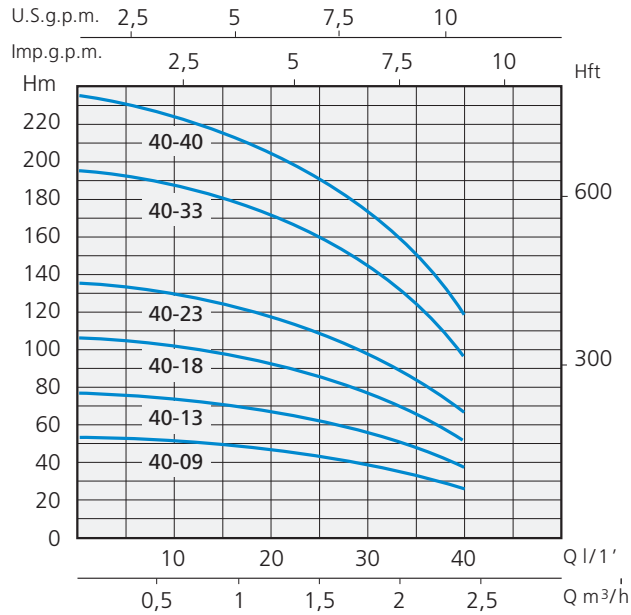

TIPO TYPE	DIMENSIONI mm - DIMENSIONS mm		
	A	B	C
SXM-SXT 40-09	346	356	702
SXM-SXT 40-13	365	440	805
SXM-SXT 40-18	380	545	925
SXM-SXT 40-23	405	650	1055
SXM-SXT 40-33	440	883	1323
SXM-SXT 40-40	495	1030	1525

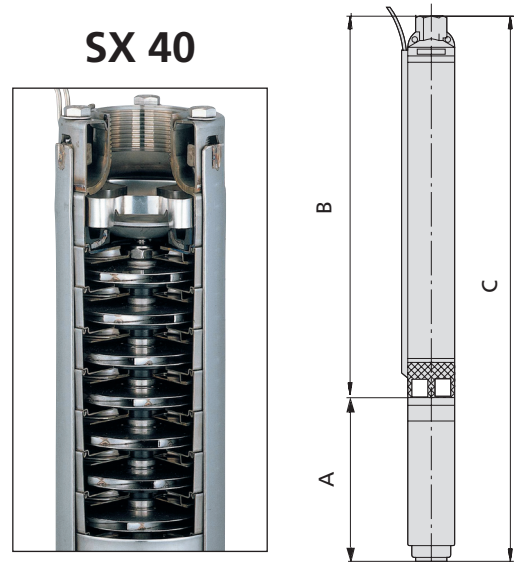

TIPO - TYPE		POTENZA NOMINALE NOMINAL POWER		STADI STAGES	Q = PORTATA - CAPACITY									
Monofase Single-phase	Trifase Three-phase	P2			m ³ /h	0	0,3	0,6	0,9	1,2	1,5	1,8	2,1	2,4
230V-50Hz	400V-50Hz	HP	kW	lt/1'	0	5	10	15	20	25	30	35	40	
Prevalenza manometrica totale in m.C.A. - Total head in meters w.c.														
SXM 40-09	SXT 40-09	0,5	0,37	9	53	52	51	50	47	42	38	33	26	1" 1/4
SXM 40-13	SXT 40-13	0,75	0,55	13	77	75	73	71	68	61	56	48	38	1" 1/4
SXM 40-18	SXT 40-18	1	0,75	18	106	104	102	98	92	84	77	66	51	1" 1/4
SXM 40-23	SXT 40-23	1,5	1,1	23	136	133	130	124	118	108	98	84	67	1" 1/4
SXM 40-33	SXT 40-33	2	1,5	33	195	191	186	181	171	157	141	120	97	1" 1/4
SXM 40-40	SXT 40-40	3	2,2	40	236	230	225	218	205	190	170	142	119	1" 1/4

APPLICAZIONI

Elettropompe sommerse multistadio per pozzi profondi da 4" (DN 100 mm). Particolarmente adatte per applicazioni civili e industriali, alimentazione getti d'acqua e fontane, impianti antincendio, l'irrigazione in generale e per l'approvvigionamento di acqua pulita.

APPLICATION

Multistage submersible water pumps for 4" deep wells (DN 100 mm). Particularly suitable for civil and industrial purposes, for sprinkler and food irrigation plants, in fire installations and generally speaking for clean water supplying.

LIMITI D'IMPIEGO

- Profondità max. di immersione 150 mt
- Temperatura liquido fino a 35°C (per un uso domestico secondo EN 60335-2-41)
- Temperatura max. liquido: 35°C (per altri impieghi)
- Contenuto di sabbia max. 50 g/m³
- Partenza/ora 20 max.

MOTORE

- Motore elettrico ad induzione a 2 poli (n=2850 min⁻¹)
- Motore sommerso in bagno d'olio
- Isolamento Classe F
- Protezione IP 68
- Servizio continuo

MATERIALI MOTORE

- Camicia esterna Acciaio inox AISI 304
- Albero motore Acciaio inox AISI 304
- Supporto superiore Ghisa zincata
- Tenuta meccanica Ceramica/Grafite

MATERIALI POMPE

- Camicia esterna Acciaio inox AISI 304
- Albero motore Acciaio inox AISI 304
- Stadi e giranti Acciaio inox AISI 304

OPERATING CONDITIONS

- Max. depth of immersion 150 mt
- Liquid temperature up to 35°C (for home use according to EN 60335-2-41)
- Temperature max. liquid: 35°C (for other uses)
- Sand content max. 50 g/m³
- Start/hour 20 max.

MOTOR

- Two-pole induction motor (n=2850 min⁻¹)
- Submersible motor in oil bath
- Class F Insulation
- IP 68 Protection
- Continuous duty

MOTOR MATERIALS

- External casing Stainless steel AISI 304
- Motor shaft Stainless steel AISI 304
- Upper bracket Zinc plated Cast Iron
- Mechanical seal Ceramic/Graphite

PUMP MATERIALS

- External casing Stainless steel AISI 304
- Motor shaft Stainless steel AISI 304
- Stages and impellers Stainless steel AISI 304

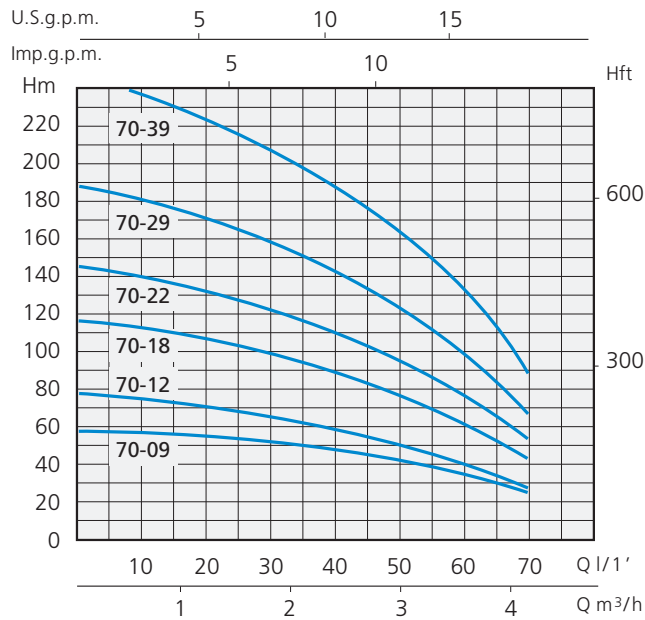

TIPO TYPE	DIMENSIONI mm - DIMENSIONS mm		
	A	B	C
SXM-SXT 70-09	365	356	721
SXM-SXT 70-12	380	419	799
SXM-SXT 70-18	405	545	950
SXM-SXT 70-22	440	629	1069
SXM-SXT 70-29	495	776	1271
SXT 70-39	607	1009	1616

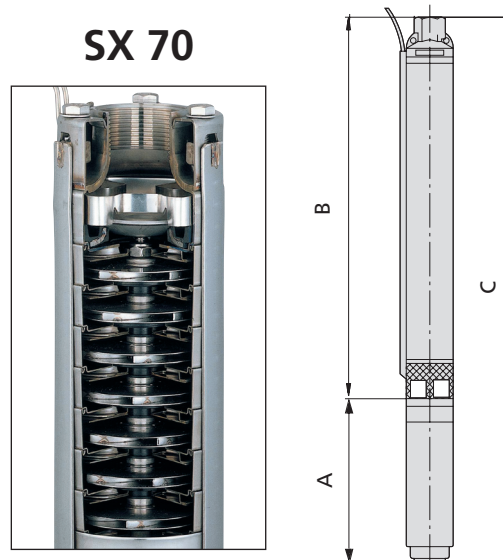

TIPO - TYPE		POTENZA NOMINALE NOMINAL POWER		STADI STAGES	Q = PORTATA - CAPACITY												DNM
Monofase Single-phase	Trifase Three-phase	P2			m³/h	0	0,9	1,2	1,5	1,8	2,1	2,4	2,7	3	3,6	4,2	
230V-50Hz	400V-50Hz	HP	kW	lt/1'	0	15	20	25	30	35	40	45	50	60	70		
Prevalenza manometrica totale in m.C.A. - Total head in meters w.c.																	
SXM 70-09	SXT 70-09	0,75	0,55	9	H (m)	58	57	55	54	52	49	48	47	43	36	25	1" 1/4
SXM 70-12	SXT 70-12	1	0,75	12		78	74	70	67	65	62	59	56	52	42	28	1" 1/4
SXM 70-18	SXT 70-18	1,5	1,1	18		117	114	108	101	98	93	89	83	78	64	42	1" 1/4
SXM 70-22	SXT 70-22	2	1,5	22		143	136	130	123	120	115	110	103	96	77	52	1" 1/4
SXM 70-29	SXT 70-29	3	2,2	29		188	180	170	162	155	149	142	133	122	98	67	1" 1/4
	SXT 70-39	4	3	39		250	240	225	215	208	199	190	179	165	136	89	1" 1/4

INOX MULTISTAGE SUBMERSIBLE PUMPS FOR 4" WELLS



APPLICAZIONI

Elettropompe sommerse multistadio per pozzi profondi da 4" (DN 100 mm). Particolarmente adatte per applicazioni civili e industriali, alimentazione getti d'acqua e fontane, impianti antincendio, l'irrigazione in generale e per l'approvvigionamento di acqua pulita.

APPLICATION

Multistage submersible water pumps for 4" deep wells (DN 100 mm). Particularly suitable for civil and industrial purposes, for sprinkler and food irrigation plants, in fire installations and generally speaking for clean water supplying.

LIMITI D'IMPIEGO

- Profondità max. di immersione 150 mt
- Temperatura liquido fino a 35°C (per un uso domestico secondo EN 60335-2-41) Temperatura max. liquido: 35°C (per altri impieghi)
- Contenuto di sabbia max. 50 g/m³
- Partenza/ora 20 max.

MOTORE

- Motore elettrico ad induzione a 2 poli (n=2850 min⁻¹)
- Motore sommerso in bagno d'olio
- Isolamento Classe F
- Protezione IP 68
- Servizio continuo

MATERIALI MOTORE

- Camicia esterna Acciaio inox AISI 304
- Albero motore Acciaio inox AISI 304
- Supporto superiore Ghisa zincata
- Tenuta meccanica Ceramica/Grafite

MATERIALI POMPE

- Camicia esterna Acciaio inox AISI 304
- Albero motore Acciaio inox AISI 304
- Stadi e giranti Acciaio inox AISI 304

OPERATING CONDITIONS

- Max. depth of immersion 150 mt
- Liquid temperature up to 35°C (for home use according to EN 60335-2-41) Temperature max. liquid: 35°C (for other uses)
- Sand content max. 50 g/m³
- Start/hour 20 max.

MOTOR

- Two-pole induction motor (n=2850 min⁻¹)
- Submersible motor in oil bath
- Class F Insulation
- IP 68 Protection
- Continuous duty

MOTOR MATERIALS

- External casing Stainless steel AISI 304
- Motor shaft Stainless steel AISI 304
- Upper bracket Zinc plated Cast Iron
- Mechanical seal Ceramic/Graphite

PUMP MATERIALS

- External casing Stainless steel AISI 304
- Motor shaft Stainless steel AISI 304
- Stages and impellers Stainless steel AISI 304

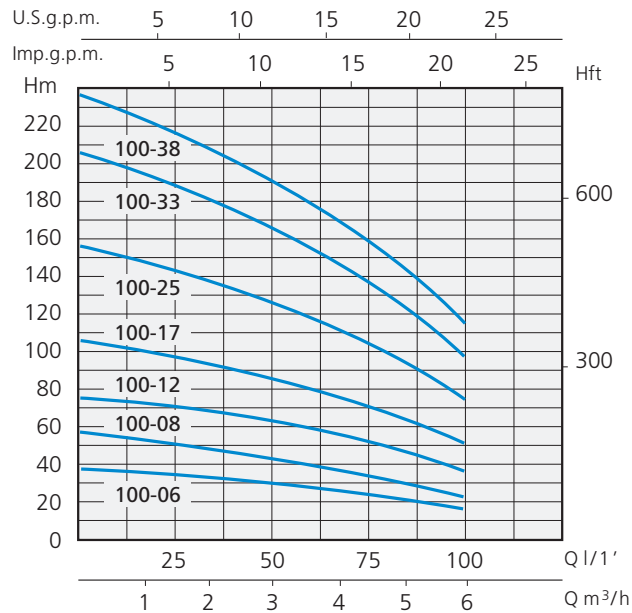

TIPO - TYPE	DIMENSIONI mm - DIMENSIONS mm		
	A	B	C
SXM-SXT 100-06	365	293	658
SXM-SXT 100-08	380	335	715
SXM-SXT 100-12	405	419	824
SXM-SXT 100-17	440	524	964
SXM-SXT 100-25	495	692	1187
SXT 100-33	607	868	1475
SXT 100-38	683	973	1656

SX 100

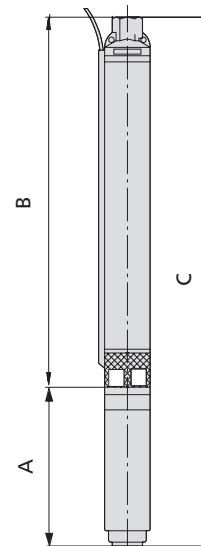

TIPO - TYPE		POTENZA NOMINALE NOMINAL POWER		STADI STAGES	Q = PORTATA - CAPACITY												DNM										
Monofase Single-phase	Trifase Three-phase	P2			m ³ /h	0	1,8	2,1	2,4	2,7	3	3,6	4,2	4,8	5,4	6		lt/1'	0	30	35	40	45	50	60	70	80
230V-50Hz	400V-50Hz	HP	kW	Prevalenza manometrica totale in m.C.A. - Total head in meters w.c.																							
SXM 100-06	SXT 100-06	0,75	0,55	6	38	34	33	32	31	30	28	26	24	21	17	1"½											
SXM 100-08	SXT 100-08	1	0,75	8	57	44	43	42	41	40	38	35	32	28	22	1"½											
SXM 100-12	SXT 100-12	1,5	1,1	12	75	68	66	65	64	63	58	53	49	42	36	1"½											
SXM 100-17	SXT 100-17	2	1,5	17	106	95	92	90	87	85	79	73	67	58	50	1"½											
SXM 100-25	SXT 100-25	3	2,2	25	156	140	136	131	129	127	118	110	100	90	74	1"½											
	SXT 100-33	4	3	33	206	182	178	173	170	165	155	142	130	115	98	1"½											
	SXT 100-38	5,5	4	38	237	210	205	199	195	190	178	165	151	135	113	1"½											

APPLICAZIONI

Elettropompe sommerse multistadio per pozzi profondi da 4" (DN 100 mm). Particolarmente adatte per applicazioni civili e industriali, alimentazione getti d'acqua e fontane, impianti antincendio, l'irrigazione in generale e per l'approvvigionamento di acqua pulita.

APPLICATION

Multistage submersible water pumps for 4" deep wells (DN 100 mm). Particularly suitable for civil and industrial purposes, for sprinkler and food irrigation plants, in fire installations and generally speaking for clean water supplying.

LIMITI D'IMPIEGO

- Profondità max. di immersione 150 mt
- Temperatura liquido fino a 35°C (per un uso domestico secondo EN 60335-2-41)
- Temperatura max. liquido: 35°C (per altri impieghi)
- Contenuto di sabbia max. 50 g/m³
- Partenza /ora 20 max.

MOTORE

- Motore elettrico ad induzione a 2 poli (n=2850 min⁻¹)
- Motore sommerso in bagno d'olio
- Isolamento Classe F
- Protezione IP 68
- Servizio continuo

MATERIALI MOTORE

- Camicia esterna: Acciaio inox AISI 304
- Albero motore: Acciaio inox AISI 304
- Supporto superiore: Ghisa zincata
- Tenuta meccanica: Ceramica/Grafite

MATERIALI POMPE

- Camicia esterna: Acciaio inox AISI 304
- Albero motore: Acciaio inox AISI 304
- Stadi e giranti: Acciaio inox AISI 304

OPERATING CONDITIONS

- Max. depth of immersion 150 mt
- Liquid temperature up to 35°C (for home use according to EN 60335-2-41)
- Temperature max. liquid: 35°C (for other uses)
- Sand content max. 50 g/m³
- Start/hour 20 max.

MOTOR

- Two-pole induction motor (n=2850 min⁻¹)
- Submersible motor in oil bath
- Class F Insulation
- IP 68 Protection
- Continuous duty

MOTOR MATERIALS

- External casing: Stainless steel AISI 304
- Motor shaft: Stainless steel AISI 304
- Upper bracket: Zinc plated Cast Iron
- Mechanical seal: Ceramic/Graphite

PUMP MATERIALS

- External casing: Stainless steel AISI 304
- Motor shaft: Stainless steel AISI 304
- Stages and impellers: Stainless steel AISI 304

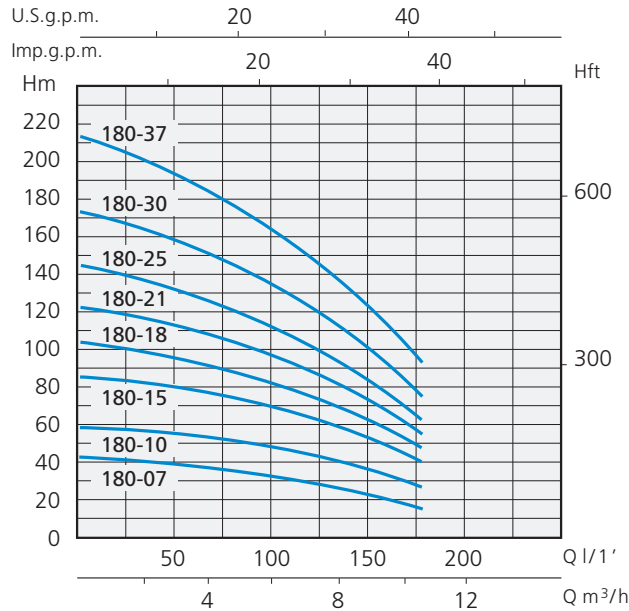

TIPO - TYPE	DIMENSIONI mm - DIMENSIONS mm		
	A	B	C
SXM-SXT 180-07	405	496	901
SXM-SXT 180-10	440	622	1062
SXM-SXT 180-15	495	832	1327
SXT 180-18	607	958	1565
SXT 180-21	683	1084	1767
SXT 180-25	683	1252	1935
SXT 180-30	683	1462	2145
SXT 180-37	783	1753	2536

SX 180

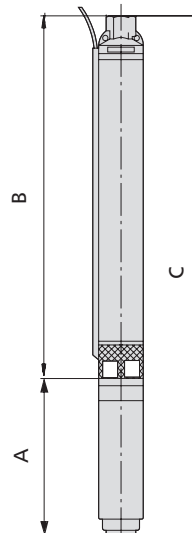

TIPO - TYPE		POTENZA NOMINALE NOMINAL POWER		STADI STAGES	Q = PORTATA - CAPACITY													DNM	
Monofase Single-phase	Trifase Three-phase	P2			m³/h	0	2,4	2,7	3	3,6	4,2	4,8	5,4	6	7,2	8,4	9,6		10,8
230V-50Hz	400V-50Hz	HP	kW	lt/1'	0	40	45	50	60	70	80	90	100	120	140	160	180		
Prevalenza manometrica totale in m.C.A. - Total head in meters w.c.																			
SXM 180-07	SXT 180-07	1,5	1,1	7	H (m)	41	36	35	34	34	33	33	32	32	29	25	20	15	2"
SXM 180-10	SXT 180-10	2	1,5	10		58	52	52	51	51	50	50	49	49	46	40	34	27	2"
SXM 180-15	SXT 180-15	3	2,2	15		86	79	78	77	76	75	73	72	70	66	60	50	40	2"
	SXT 180-18	4	3	18		103	91	90	89	88	87	85	83	81	77	70	60	48	2"
	SXT 180-21	5	3,7	21		121	111	110	108	106	104	102	100	98	91	82	71	54	2"
	SXT 180-25	5,5	4	25		144	131	130	128	126	122	119	116	113	107	97	81	61	2"
	SXT 180-30	7,5	5,5	30		173	155	153	151	149	147	143	139	136	127	114	97	74	2"
	SXT 180-37	10	7,5	37		213	192	190	188	184	180	175	170	165	154	139	118	92	2"

INOX MULTISTAGE SUBMERSIBLE PUMPS FOR 4" WELLS



APPLICAZIONI

Elettropompe sommerse multistadio per pozzi profondi da 4" (DN 100 mm). Particolarmente adatte per applicazioni civili e industriali, alimentazione getti d'acqua e fontane, impianti antincendio, l'irrigazione in generale e per l'approvvigionamento di acqua pulita.

APPLICATION

Multistage submersible water pumps for 4" deep wells (DN 100 mm). Particularly suitable for civil and industrial purposes, for sprinkler and food irrigation plants, in fire installations and generally speaking for clean water supplying.

LIMITI D'IMPIEGO

- Profondità max. di immersione 150 mt
- Temperatura liquido fino a 35°C (per un uso domestico secondo EN 60335-2-41)
- Temperatura max. liquido: 35°C (per altri impieghi)
- Contenuto di sabbia max. 50 g/m³
- Partenza /ora 20 max.

MOTORE

- Motore elettrico ad induzione a 2 poli (n=2850 min⁻¹)
- Motore sommerso in bagno d'olio
- Isolamento Classe F
- Protezione IP 68
- Servizio continuo

MATERIALI MOTORE

- Camicia esterna: Acciaio inox AISI 304
- Albero motore: Acciaio inox AISI 304
- Supporto superiore: Ghisa zincata
- Tenuta meccanica: Ceramica/Grafite

MATERIALI POMPE

- Camicia esterna: Acciaio inox AISI 304
- Albero motore: Acciaio inox AISI 304
- Stadi e giranti: Acciaio inox AISI 304

OPERATING CONDITIONS

- Max. depth of immersion 150 mt
- Liquid temperature up to 35°C (for home use according to EN 60335-2-41)
- Temperature max. liquid: 35°C (for other uses)
- Sand content max. 50 g/m³
- Start/hour 20 max.

MOTOR

- Two-pole induction motor (n=2850 min⁻¹)
- Submersible motor in oil bath
- Class F Insulation
- IP 68 Protection
- Continuous duty

MOTOR MATERIALS

- External casing: Stainless steel AISI 304
- Motor shaft: Stainless steel AISI 304
- Upper bracket: Zinc plated Cast Iron
- Mechanical seal: Ceramic/Graphite

PUMP MATERIALS

- External casing: Stainless steel AISI 304
- Motor shaft: Stainless steel AISI 304
- Stages and impellers: Stainless steel AISI 304

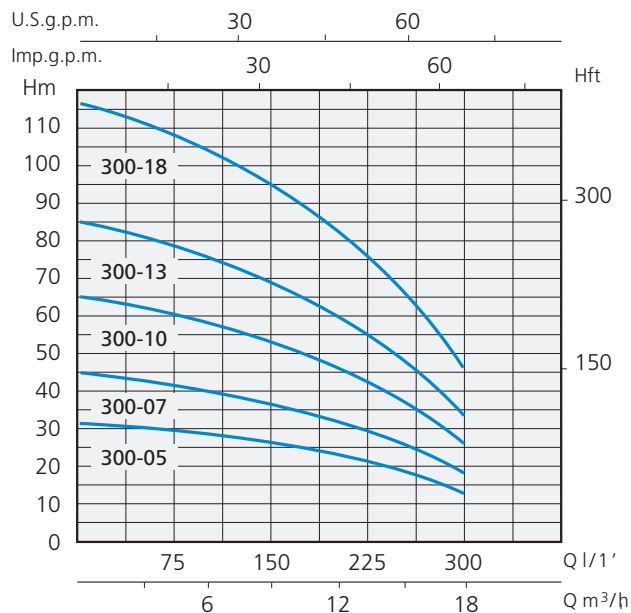

TIPO TYPE	DIMENSIONI mm - DIMENSIONS mm		
	A	B	C
SXM-SXT 300-05	440	505	945
SXM-SXT 300-07	495	635	1130
SXT 300-10	607	830	1437
SXT 300-13	683	1025	1708
SXT 300-18	683	1350	2033

SX 300

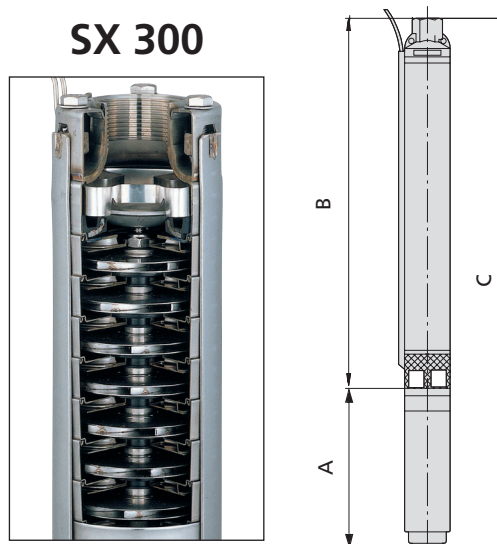

TIPO - TYPE		POTENZA NOMINALE NOMINAL POWER		STADI STAGES	Q = PORTATA - CAPACITY											DNM
Monofase Single-phase	Trifase Three-phase	P2			m³/h	0	3,6	5,4	6	7,2	8,4	9,6	10,8	12	15	
230V-50Hz	400V-50Hz	HP	KW		lt/1'	0	60	90	100	120	140	160	180	200	250	300
SXM 300-05	SXT 300-05	2	1,5	5	Prevalenza manometrica totale in m.C.A. - Total head in meters w.c.											
				H (m)	32	31	30	29	28	27	26	25	23	19	13	2"
					45	44	42	40	39	37	36	35	32	26	18	2"
					65	63	61	58	56	54	52	50	46	38	26	2"
					85	83	78	75	72	70	67	65	60	49	34	2"
					117	114	110	104	100	97	93	90	83	68	46	2"