

Koyo[®]

Torrington[®] Needle Roller Bearings

Needle Roller Bearings



JTEKT

JTEKT CORPORATION

JTEKT

Koyo | **TOYODA**

CAT. NO. B2016E-4

★ The contents of this catalog are subject to change without prior notice. Every possible effort has been made to ensure that the data herein is correct; however, JTEKT cannot assume responsibility for any errors or omissions.

Reproduction of this catalog without written consent is strictly prohibited

INDEX

A

ENGINEERING

Introduction	A-3
Bearing Types and Cages	A-4
Bearing Reactions, Dynamic Equivalent Loads and Bearing Life	A-4
System Life and Weighted Average Life	A-11
Bearing Tolerances, Inch and Metric	A-12
Mounting Designs	A-25
Shaft Designs	A-27
Housing Designs	A-28
Lubrication and Seals	A-29
Limiting Speed	A-35
Torque	A-36

B

NEEDLE ROLLER BEARINGS

Radial Needle Roller and Cage Assemblies	B-3
Drawn Cup Needle Roller Bearings	B-41
Drawn Cup Roller Clutches	B-123
Heavy-Duty Needle Roller Bearings	B-143
Track Rollers	B-205
Thrust Bearings, Assemblies, Washers	B-267
Combined Needle Roller Bearings	B-327
Needle Rollers, Accessories	B-347

C

NEEDLE BEARING APPLICATIONS

Automatic Transmissions	C-4
Manual Transmissions	C-6
Valvetrain Components	C-8
Steering Columns	C-9
Automotive Accessories	C-10
Drivetrain Components	C-12
Power Transmissions	C-13
Sport Vehicles	C-14
Marine Applications	C-16
Power Tools	C-18
Consumer Products	C-19
Mechanical Pumps	C-20
Industrial Machinery	C-21

D

SUPPLEMENTARY TABLES

Conversion Table	D-4
Designation Suffixes	D-8
Symbols and Terms	D-9
Index	D-11

PRODUCT BREADTH

A complete line of needle roller bearing designs ranging from 3 to 160 mm bore ($\frac{1}{8}$ to $6\frac{1}{4}$ in) is offered.

DRAWN CUP NEEDLE ROLLER BEARINGS, available in 3 mm to 140 mm bore ($\frac{1}{8}$ to $5\frac{1}{2}$ in), are designed to support radial loads and reduce friction between rotating components. The low cross section of the drawn cup bearing provides maximum load-carrying capability with minimum space required.

DRAWN CUP ROLLER CLUTCHES AND BEARING ASSEMBLIES, available in 3 to 30 mm bore ($\frac{1}{8}$ to $1\frac{1}{4}$ in), are designed to transmit torque between the shaft and housing in one direction and allow free overrun in the opposite direction. When transmitting torque, either the shaft or the housing can be the input member.

ROLLER AND CAGE ASSEMBLIES, available in 3 mm to 165 mm bore ($\frac{1}{8}$ to $6\frac{1}{2}$ in), consist of a complement of needle rollers held in place by a cage. With no inner or outer ring, the low cross section provides maximum load-carrying capability within the smallest envelope. The mating shaft and housing are normally used as inner and outer raceways.

THRUST BEARING ASSEMBLIES AND WASHERS, available in 5 mm to 160 mm ($\frac{3}{16}$ to $6\frac{1}{4}$ in) bore, consist of a complement of needle rollers held in place by a cage.

Needle roller and cage thrust assemblies are complements of small diameter needle rollers arranged in a spoke-like configuration. Needle rollers are equally spaced by means of a cage whose web section separates the rollers and provides guidance to keep them tracking in an orbital path. The purpose of these assemblies is to transmit a thrust load between two relatively rotating objects while greatly reducing friction.

Needle roller and cage thrust assemblies also can be unitized with lipped washers which service as raceway surfaces for the needle rollers. Washers can be supplied separately or can be mechanically unitized to the needle roller thrust assemblies for ease of handling.

HEAVY-DUTY NEEDLE ROLLER BEARINGS, available in 5 mm to 100 mm bore ($\frac{3}{16}$ to 4 in), consist of a machined and ground channel-shaped outer ring with a complement of needle rollers retained and guided by a cage. The thick outer ring provides maximum load capacity and shock resistance with a relatively small radial cross section.

TRACK ROLLERS/CAM FOLLOWERS, available in 10 mm to 300 mm O.D. ($\frac{3}{8}$ to $4\frac{1}{4}$ in), are characterized by their thick-walled outer rings that run directly on a track. The thick outer rings permit high load-carrying capability while minimizing distortion and bending stresses.

ENGINE BEARINGS include a full line of advanced bearing assemblies for automotive engine valve trains. These assemblies help reduce friction and optimize performance in both overhead valve and overhead cam engines. They include roller rocker arms for overhead valve (pushrod) engines, roller finger followers for overhead cam engines, valve lifter rollers for overhead valve and overhead cam engines.

PRECISION NEEDLE ROLLERS have multiple uses in a variety of industries including automotive, truck, farm and construction equipment, two-cycle engines, outboard engines and consumer durables. Needle rollers are mainly used as bearing rolling elements to transmit torque and reduce friction. They also can serve as precision shafts or as precision locating pins.

PLANETARY GEAR SHAFTS have multiple uses in a variety of industries including automotive, truck and farm and construction equipment. The shafts are used in planetary gear sets, differentials and engine valve trains.

PRECISION PINS AND SHAFTS are crafted from the highest quality steel within a TS16949/ISO9000/AS9100-certified manufacturing facility. Pins and shafts come in a larger variety of configurations and materials and flexible product volumes. These pins and shafts are found in applications such as gasoline fuel systems components, diesel systems components, aerospace rollers and precision rollers (DFAR-compliant), planet pins, racing applications, rollers for bearing assemblies, gear shafts and steering column pins.

NEEDLE ROLLER BEARINGS

To identify: NEEDLE ROLLER AND CAGE RADIAL ASSEMBLY

As a general rule, there are no identifiable markings on needle roller and cage radial assemblies to indicate the bearing part number. Parts are specified by bore diameter, outside diameter and width (e.g. K24x28x10H).



To identify: STUD-TYPE TRACK ROLLERS

The complete bearing part number is marked on the stud face or stamped on the face of the outer ring (e.g. KRE22.2RS). Yoke-type track rollers (without stud, not shown) have the part stamped on the face of the inner or outer ring.

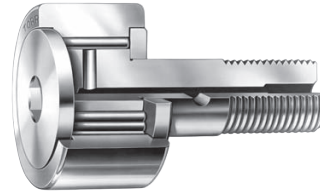

To identify: NEEDLE ROLLER THRUST BEARINGS

As a general rule, there are no identifiable markings on needle roller and cage radial assemblies to indicate the bearing part number. Parts are specified by bore diameter and outside diameter (e.g. AXK1024).



To identify: COMBINATION BEARINGS

As a general rule, there are no identifiable markings on combination bearings to indicate the bearing part number. Parts are specified by the product series and bore diameter (e.g. RAXZ510).



To identify: DRAWN CUP NEEDLE ROLLER BEARINGS AND DRAWN CUP ROLLER CLUTCHES

The complete bearing part number is stamped on the face of the outer ring (e.g. HK1412, FCL-10-K). Also, on clutch assemblies, the mounted clutch assembly engages when the housing is rotated relative to the shaft in the direction of the arrow and the word LOCK stamped on the outer ring.



To identify: NEEDLE/CYLINDRICAL ROLLERS

As a general rule, there are no identifiable markings on loose rollers to indicate the part number. They are packaged in bulk or in strips. Loose rollers are specified by the product series, end geometry, diameter and nominal length (e.g. NRO.B 1.5x11.8 G2).





ENGINEERING

A

A ENGINEERING

<i>Introduction</i>	A-3
<i>Bearing Types and Cages</i>	A-4
<i>Bearing Reactions, Dynamic Equivalent Loads and Bearing Life</i>	A-4
<i>System Life and Weighted Average Life</i>	A-11
<i>Bearing Tolerances, Inch and Metric</i>	A-12
<i>Mounting Designs</i>	A-25
<i>Shaft Designs</i>	A-27
<i>Housing Designs</i>	A-28
<i>Lubrication and Seals</i>	A-29
<i>Limiting Speeds</i>	A-35
<i>Torque</i>	A-36

A

ENGINEERING

A

INTRODUCTION

Where more complex bearing applications are involved, your representative should be consulted. The following topics are covered within this section:

- Bearing types.
- Cages.
- Internal clearances.
- Tolerances.
- Shaft and housing fits and shoulders.
- Load ratings and life calculations.
- Lubrication.
- Materials.
- Speed ratings.

NEEDLE ROLLER BEARING SELECTION

Because of the possible combinations of roller complement orientation, bearing cross section thickness and raceway construction needle roller bearings should be given extra

consideration for roller bearing applications selection. The table below should be used as a general guideline for the application of needle roller bearings.

Table A-1. Needle roller bearing capability comparison based on suitable oil lubrication

Bearing type/ design capability	Radial needle roller and cage assembly	Drawn cup needle roller bearing caged	Drawn cup roller bearing full complement	Needle roller bearing and inner ring	Track roller	Thrust needle roller and cage assembly	Needle rollers	Combination bearing radial/thrust
Radial load	High	Moderate	High	High	Moderate	None	Very high	High
Axial load	None	None	None	None	Low	Very high	None	High
Limiting speed	Very high	High	Moderate	Very high	Moderate	High	Moderate	Moderate
Slope tolerance	Moderate	Moderate	Very low	Moderate	Moderate ⁽¹⁾	Low	Very low	Low
Grease life	High	High	Low	High	Moderate	Low	Low	Low
Friction	Very low	Very low	High	Very low	Low ⁽²⁾	Moderate	High	Moderate
Precision	Very high	Moderate	Moderate	High	High	High	Very high	High
Cross section	Very low	Low	Low	Moderate	High	Very low	Very low	High
Cost	Low	Low	Low	High	High	Moderate	Very low	Very high

⁽¹⁾ "Moderate" for full complement track rollers

⁽²⁾ "Low" for full complement track rollers



**Radial needle roller
and cage assembly**



Drawn cup needle roller



Heavy-duty needle roller

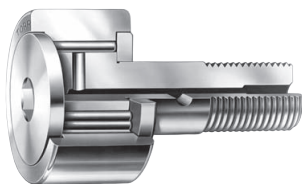

Track roller



**Thrust needle roller
and cage assembly**



Combined radial/thrust



Drawn cup roller clutch

BEARING TYPES AND CAGES

NEEDLE ROLLER BEARINGS

Needle roller bearings are an economical alternative for applications requiring minimal space to carry a given load at a desired speed. Needle roller bearings can be an ideal choice because of their ability to handle a given level of speed and load capacity, yet have the smallest cross section of all roller bearing types.

We offer both inch and metric nominal bearings in popular designs such as: drawn cups, radial caged needle rollers, machined ring, track rollers, thrust bearings, combined bearings, and drawn cup roller clutches. Most of these bearing types can be operated directly on a machined shaft of suitable quality, or with a matching inner ring where this requirement cannot be conventionally satisfied.

Radial Needle Roller and Cage Assemblies

Radial needle roller and cage assemblies have a steel cage that provides both inward and outward retention for the needle rollers. The designs provide maximum cage strength consistent with the inherently high load ratings of needle roller bearings. Accurate guidance of the needle rollers by the cage bars allows for operation at high speeds. Also available are needle roller and cage assemblies using molded, one-piece glass-reinforced engineered polymer cages. Needle roller and cage assemblies are manufactured with either one or two rows of needle rollers.

Drawn Cup Bearings

The outer ring in the form of a cup is accurately drawn and no subsequent machining is performed to build the outer raceway. Drawn cup needle roller bearings are available in open ends or single, closed-end designs. They also are available with one or two integral seals. Other options include a single lubricating hole and matching inner ring.

Heavy-Duty (Machined) Needle Roller Bearings

These bearings are available in a wide range of inch and metric sizes plus an array of design features including: integral seals, side flanges (or separate end washers), inner rings, oil holes and single or double caged sets (or full complement) of rollers.

Track Rollers

Track rollers listed in this catalog are designed with outer rings of large radial cross section to withstand heavy rolling and shock loads on track-type or cam-controlled equipment. The outside diameters of the outer rings are either profiled or cylindrical. Profiled track rollers are designed to alleviate uneven bearing loading resulting from deflection, bending or misalignment in mounting. Stud-type track rollers are available with or without lip contact seals, or with shields. Yoke-type track rollers are designed for straddle mounting. Each yoke-type is available with either radial needle roller and cage assemblies, or with a single (or double) full complement row of cylindrical or needle rollers.

Thrust Bearings

Thrust needle roller and cage assemblies are available in a variety of inch or metric sizes. All types have very small cross sections. If the back up surfaces cannot be used as raceways, hardened washers are available. Thrust bearings are available with needle rollers or heavier cylindrical rollers for high load-carrying capacity.

Combined (Radial and Thrust) Bearings

Combined bearings consist of a radial bearing (needle roller bearing) and a thrust bearing (ball or roller bearing). Some combined bearings are constructed similar to drawn cups, but with an added thrust bearing component. Like other needle roller bearings, these combined bearings can be matched with an optional inner ring or thrust washer as the opposing raceway.

BEARING REACTIONS, DYNAMIC EQUIVALENT LOADS AND BEARING LIFE

DEFINITION OF LOAD RATINGS

Basic Dynamic Load Rating

The "basic dynamic load rating" (C) for a radial roller bearing is that calculated, constant, radial load, which a group of apparently identical bearings with stationary outer ring can theoretically endure for a rating life of one million revolutions of the inner ring. For a thrust roller bearing (C) is that calculated, constant, centric thrust load, which a group of apparently identical bearings can theoretically endure for a rating life of one million revolutions of one of the bearing washers. The basic dynamic load rating is a reference value only, the base value of one million revolutions has been chosen for ease of calculation. Since applied loading as great as the basic dynamic load tends to cause local plastic deformation of the rolling surfaces, it is not anticipated that such heavy loading would normally be applied.

Basic Static Load Rating

Basic static load rating for a radial roller bearing suitably manufactured from a good quality hardened alloy steel, the static radial load rating (C_0) is that uniformly distributed static radial bearing load, which produces a maximum contact stress of 4000 megapascals (580,000 psi) acting at the center of contact of the most heavily loaded rolling element. The static axial load rating (C_{0a}) is that uniformly distributed static centric axial load, which produces a maximum contact stress of 4000 megapascals (580,000 psi) acting at the center of contact of each rolling element.

Note: For a contact stress of 4000 megapascals (580,000 psi) a total permanent deformation of roller and raceway occurs, which is approximately 0.0001 of the roller diameter.

EQUIVALENT DYNAMIC RADIAL BEARING LOADS (P_R)

To calculate the L_{10} life, it is necessary to calculate a dynamic equivalent radial load, designated by P_r . The dynamic equivalent radial load is defined as a single radial load that, if applied to the bearing, will result in the same life as the combined loading under which the bearing operates.

$$P_r = XF_r + YF_a$$

Where:

- P_r = Dynamic equivalent radial load
- F_r = Applied radial load
- F_a = Applied axial load
- X = Radial load factor
- Y = Axial load factor

Radial needle roller bearings are designed to carry radial load with zero thrust load under normal conditions. With the thrust load equal to zero, equivalent radial load (P_r) is equal to the design radial load (F_r). Your representative should be consulted on any applications where thrust load is involved (as the resulting increase in internal friction may require cooling to prevent increased operating temperatures).

MINIMUM BEARING LOAD

Slippage can occur if loads are too light and, if accompanied by inadequate lubrication, can cause damage to the bearings. The minimum load for radial cylindrical, spherical and full complement needle roller bearings is: $P/C = 0.04$ (P is the dynamic load and C is the basic dynamic load rating).

Thrust needle roller bearings also have an added design requirement such that the minimum thrust load is satisfied to prevent the rollers from skidding on the raceway. The equation for the thrust loading force is different for needle rollers versus cylindrical rollers as noted:

$$\begin{aligned} \text{(needle rollers)} \quad F_{a \min} &= C_0/2200 \text{ kN} \\ \text{(cylindrical rollers)} \quad F_{a \min} &= 0.1C_0/2200 \text{ kN} \end{aligned}$$

STATIC RADIAL AND/OR AXIAL EQUIVALENT LOADS

The static equivalent radial and/or axial loading is dependent on the bearing type selected. For bearings designed to accommodate only radial or thrust loading, the static equivalent load is equal to the applied load.

For all bearings, the maximum contact stress can be approximated using the static equivalent load and the static rating.

For roller bearings:

$$\sigma_0 = 4000 \times \left(\frac{P_0}{C_0} \right)^{1/2} \text{ MPa}$$

$$\sigma_0 = 580 \times \left(\frac{P_0}{C_0} \right)^{1/2} \text{ ksi}$$

Needle Roller Bearings

Because radial needle roller bearings are not designed to accept thrust loading, their equation to determine static radial equivalent load is:

$$P_{0r} = F_r$$

Thrust needle roller bearings are not designed to accept radial loading, so their equation to determine static thrust equivalent load is:

$$P_{0a} = F_a$$

The determination of the static load safety factor (f_0) serves to ascertain that a bearing with adequate static load rating has been selected.

$$f_0 = \frac{C_0}{P_0}$$

Where:

- f_0 = Static load safety factor
- C_0 = Basic static load rating (kN or lbf)
- P_0 = Maximum applied static load (kN or lbf)

f_0 is a safety factor against permanent deformation of the contact areas of the rolling elements and raceways. Higher f_0 values are required for particularly smooth operation. The following values are generally suggested.

- $f_0 = 1.5 \dots 2.5$ for particularly smooth operation
- $f_0 = 1.0 \dots 1.5$ for smooth operation
- $f_0 = 0.7 \dots 1.0$ for less smooth operation

For drawn cup needle roller bearings, f_0 should be ≥ 3 .

BEARING LIFE

Many different performance criteria exist that dictate how a bearing should be selected. These include bearing fatigue life, rotational precision, power requirements, temperature limits, speed capabilities, sound, etc. This publication deals primarily with bearing life as related to material-associated fatigue. Bearing life is defined here as the length of time, or number of revolutions, until a fatigue spall of 6 mm² (0.0100 in²) develops. Since metal fatigue is a statistical phenomenon, the life of an individual bearing is impossible to precisely predetermine. Bearings that may appear to be identical can exhibit considerable life scatter when tested under identical conditions. Thus, it is necessary to base life predictions on a statistical evaluation of a large number of bearings operating under similar conditions. The Weibull distribution function is commonly used to predict the life of a population of bearings at any given reliability level.

RATING LIFE

Rating life, L₁₀, is the life that 90 percent of a group of apparently identical bearings will complete or exceed before a fatigue spall develops. The L₁₀ life also is associated with 90 percent reliability for a single bearing under a certain load.

BEARING LIFE EQUATIONS

Traditionally, the L₁₀ life has been calculated as follows for bearings under radial or combined loading where the dynamic equivalent radial load, P_r, has been determined:

$$L_{10} = \left(\frac{C}{P_r} \right)^{10/3} (1 \times 10^6) \text{ revolutions}$$

or,

$$L_{10} = \left(\frac{C}{P_r} \right)^{10/3} \left(\frac{1 \times 10^6}{60n} \right) \text{ hours}$$

Where:

n = speed (min⁻¹)

For thrust bearings, the above equations change to the following:

$$L_{10} = \left(\frac{C_a}{P_a} \right)^{10/3} (1 \times 10^6) \text{ revolutions}$$

or,

$$L_{10} = \left(\frac{C_a}{P_a} \right)^{10/3} \left(\frac{1 \times 10^6}{60n} \right) \text{ hours}$$

As the first set of equations for radial bearings with dynamic ratings based on one million revolutions is the most common form of the equations, this will be used through the rest of this section. The equivalent dynamic load equations and the life adjustment factors are applicable to all forms of the life equation.

With increased emphasis on the relationship between the reference conditions and the actual environment in which the bearing operates in the machine, the traditional life equations were expanded to include certain additional variables that affect bearing performance. The approach whereby these factors are considered in the bearing analysis and selection has been termed Bearing Systems Analysis (BSA).

The ISO/ABMA expanded bearing life equation is:

$$L_{na} = a_1 a_2 a_3 L_{10}$$

Where:

- a₁ = Reliability life factor
- a₂ = Material life factor
- a₃ = Operating condition life factor
(to be specified by the manufacturer)

The expanded bearing life equation is:

$$L_{na} = a_1 a_2 a_{3h} a_{3k} a_{3l} a_{3m} a_{3p} \left(\frac{C}{P_r} \right)^{10/3} (1 \times 10^6)$$

Where:

- a₁ = Reliability life factor
- a₂ = Material life factor
- a_{3h} = Hardness life factor
- a_{3k} = Load zone life factor
- a_{3l} = Lubrication life factor
- a_{3m} = Misalignment life factor
- a_{3p} = Low load life factor
- c = Dynamic radial load rating
- P_r = Dynamic equivalent radial load

Reliability Life Factor (a_1)

The equation for the life adjustment factor for reliability is:

$$a_1 = 4.26 \times \left(\ln \frac{100}{R} \right)^{2/3} + 0.05$$

ln = natural logarithm (base e)

To adjust the calculated L_{10} life for reliability, multiply by the a_1 factor. If 90 (90 percent reliability) is substituted for R in the above equation, $a_1 = 1$. For R = 99 (99 percent reliability), $a_1 = 0.25$. The following table lists the reliability factor for commonly used reliability values.

Table A-2. Reliability factors

R (percent)	L_n	a_1
90	L_{10}	1.00
95	L_5	0.64
96	L_4	0.55
97	L_3	0.47
98	L_2	0.37
99	L_1	0.25
99.5	$L_{0.5}$	0.175
99.9	$L_{0.1}$	0.093

Note that the equation for reliability adjustment assumes there is a short minimum life below which the probability of bearing damage is minimal (e.g., zero probability of bearing damage producing a short life). Extensive bearing fatigue life testing has shown the minimum life, below which the probability of bearing damage is negligible, to be larger than shown. For a more accurate prediction of bearing lives at high levels of reliability, consult your representative.

Material Life Factor (a_2)

The life adjustment factor for bearing material (a_2) for standard bearings manufactured from bearing quality steel, is 1.0. Bearings also are manufactured from premium steels, containing fewer and smaller inclusion impurities than standard steels and providing the benefit of extending bearing fatigue life. Application of the material life factor requires that fatigue life is limited by nonmetallic inclusions, that contact stresses are approximately less than 2400 MPa (350 ksi), and adequate lubrication is provided. It is important to note that improvements in material cannot offset poor lubrication in an operating bearing system. Consult your representative for applicability of the material factor.

Hardness Life Factor (a_{3h})

Both the dynamic and static load ratings of bearings are based on a minimum raceway hardness equivalent to 58 on the Rockwell C scale (HRC) [ASTM E-18]. If the raceway hardness must be decreased, these load ratings also will be decreased. For bearings supplied as a full assembly, the hardness life factor will be unity. For bearing applications designed to use the shaft or housing surfaces as raceways, this factor can be used to estimate performance when the required 58 HRC minimum hardness cannot be achieved.

The effective raceway hardness affects the life of a bearing application as shown in the following table. If values for raceway hardness below 45 HRC are required, consult your representative.

Table A-3. Raceway hardness factor for life equation

Raceway hardness (HRC)	a_{3h}
58	1.00
57	0.81
56	0.66
55	0.53
54	0.43
53	0.35
52	0.28
51	0.22
50	0.18
49	0.14
48	0.11
47	0.09
46	0.07
45	0.06

Table A-4. Hardness factors to modify basic static load rating (C_0/HF_s)

Raceway hardness (HRC)	Hardness factor (HFs)
58	1.00
57	1.06
56	1.13
55	1.21
54	1.29
53	1.37
52	1.46
51	1.55
50	1.65
49	1.76
48	1.88
47	2.00
46	2.13
45	2.27
44	2.41
43	2.57
42	2.74
41	2.92
40	3.10

Load Zone Life Factor (a_{3k})

The fatigue life of a bearing is a function of the stresses in rollers and raceways and the number of stress cycles that the loaded bearing surfaces experience in one bearing revolution. The stresses depend on applied load and on how many rollers support that load. The number of stress cycles depends on bearing geometry and, again, on how many rollers support the load. Therefore, life for a given external load is related to the loaded arc, or load zone, of the bearing.

The load zone in a bearing is dominated by the internal clearance, either radial or axial depending on the bearing type. Without considering preload, less clearance in a bearing results in a larger load zone and subsequently longer bearing life.

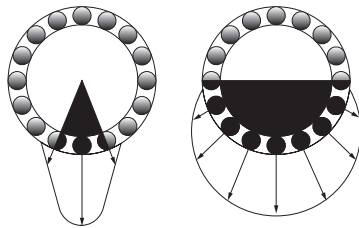

Fig. A-1. Bearing load zones and roller-raceway contact loading

If a more accurate assessment of the load zone adjusted life is necessary (e.g., including the effects of internal clearance or fitting practice), consult your representative.

Lubrication Life Factor (a_{3l})

The influence of lubrication film due to elastohydrodynamic (EHL) lubrication on bearing performance is related to the reduction or prevention of asperity (metal-metal) contact between the bearing surfaces. It has been found that the roller and raceway surface finish, relative to lubricant film thickness, has the most notable effect on improving bearing performance. Factors such as bearing geometry, material, loads and load zones also play an important role in bearing performance.

The following equation provides a method to calculate the lubrication factor for a more accurate prediction of the influence of lubrication on bearing life (L_{10a}).

$$a_{3l} = C_g \times C_\ell \times C_j \times C_s \times C_v \times C_{gr}$$

Where:

- C_g = Geometry factor
- C_ℓ = Load factor
- C_j = Load zone factor
- C_s = Speed factor
- C_v = Viscosity factor
- C_{gr} = Grease lubrication factor

Where:

- $C_{gr} = 0.79$ for grease
- 1.00 for oil

Please note that the a_{3l} maximum is 2.88 for all bearings. The a_{3l} minimum is 0.200 for case-hardened bearings and 0.126 for through hardened bearings.

A lubricant contamination factor is not included in the lubrication factor because endurance tests are typically run with a 0.040 mm (0.00157 in) filter to provide a realistic level of lubricant cleanness for most applications.

Geometry Factor (C_g)

C_g is given for most part numbers in the bearing tables. The geometry factor also includes the material effects and load zone considerations for non-tapered roller bearings, as these also are inherent to the bearing design. However, it should be noted that the primary effect of the load zone is on roller load distributions and contact stresses within the bearing, which are not quantified within the lubrication factor. Refer to the previous section, Load Zone Life Factor, a_{3k} , for more information.

Load Factor (C_ℓ)

The C_ℓ factor is obtained from the following figure. Note that the factor is different based on the type of bearing utilized. P_r is the equivalent load applied to the bearing in Newtons and is determined in the Equivalent Bearing Loads (P_r) section.

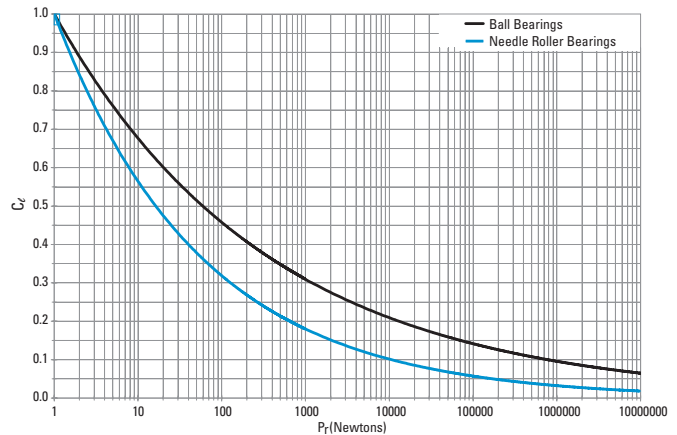

Fig. A-2. Load factor (C_ℓ) vs. equivalent bearing load (P_r)

Load Zone Factor (C_j)

For all non-tapered roller bearings, the load zone factor is unity.

Speed Factor (C_s)

C_s is determined from the following figure, where rev/min (min^{-1}) is the rotational speed of the inner ring relative to the outer ring.

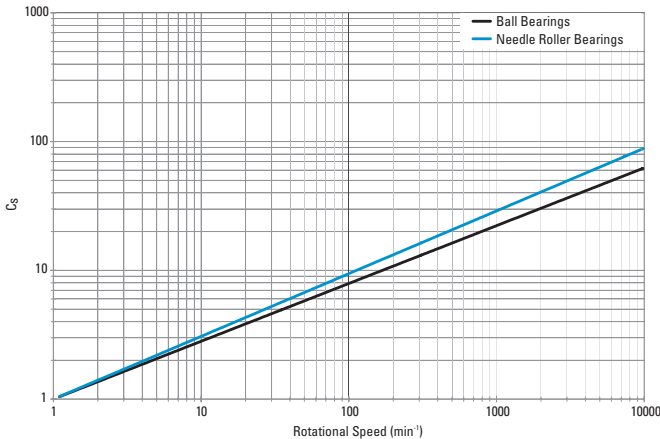

Fig. A-3. Speed factor (C_s) vs. rotational speed

Viscosity Factor (C_v)

The lubricant kinematic viscosity [centistokes (cSt)] is taken at the operating temperature of the bearing. The operating viscosity can be estimated by using the figure in the Lubricant and Seals section. The viscosity factor (C_v) can then be determined from the following figure.

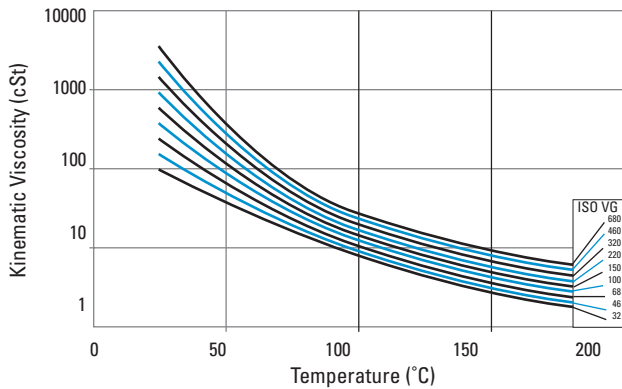

Fig. A-4. Kinematic viscosity vs. temperature

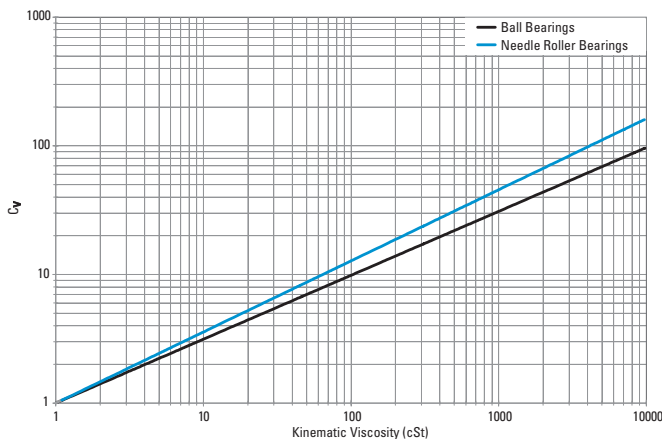

Fig. A-5. Viscosity factor (C_v) vs. kinematic viscosity

Misalignment Life Factor (a_{3m})

The effect of bearing life depends on the magnitude of the angle of misalignment, on the internal bearing geometry, and on the applied loads.

For needle roller bearings, the following table gives the misalignment limitations based on bearing width.

Table A-5. Misalignment limitations based on bearing width

Bearing width		Maximum slope	
mm	in	Caged	Full complement
>50.8	>2	0.0005	0.0005
25.4 - 50.8	1 - 2	0.0010	0.0005
<25.4	<1	0.0015	0.0010

Performance of all bearings under various levels of misalignment, radial and axial load can be predicted using sophisticated computer programs. Using these programs, engineers can design special bearing contact profiles to accommodate the conditions of radial load, axial load and/or bearing misalignment in your application. Consult your representative for more information.

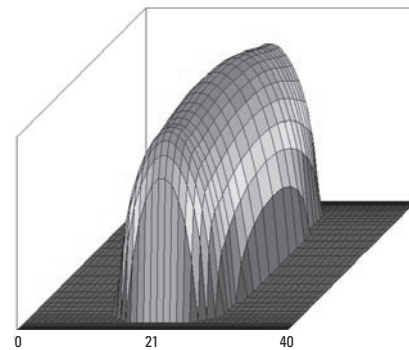

Fig. A-6. Roller-inner raceway contact stress without misalignment

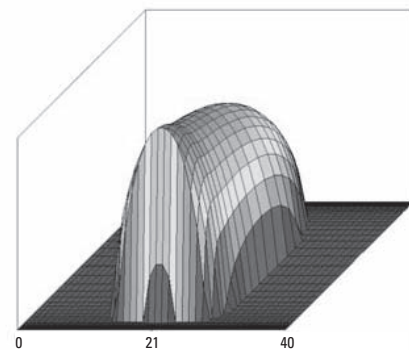

Fig. A-7. Roller-inner raceway contact stress with high misalignment and special profile

Needle Rollers With Relieved Ends

Needle roller bearing life is affected by the distribution of contact stress between roller and raceways. Even when non-profiled needle rollers are loaded under conditions of ideal alignment, the contact stress is not uniform along the length of the rollers, but rather is concentrated toward the ends. Misalignment causes even greater roller contact stress. This effect is illustrated below.

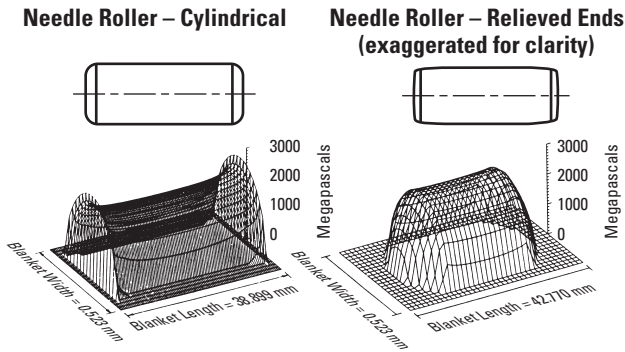

Fig. A-8. Comparative Stress Patterns

The use of needle rollers with relieved ends helps to reduce stress concentration at the ends of rollers, both under misalignment or ideal alignment, and results in more uniform stress distribution and optimum bearings performance.

Low Load Life Factor (a_{3p})

Bearing life tests have shown greatly extended bearing fatigue life performance is achievable when the bearing contact stresses are low and the lubricant film is sufficient to fully separate the micro-scale textures of the contacting surfaces. Mating the test data with sophisticated computer programs for predicting bearing performance, engineers developed a low load factor for use in the

catalog to predict the life increase expected when operating under low bearing loads. The following figure shows the low load factor (a_{3p}) as a function of the lubricant life factor (a_{3l}) and the ratio of bearing dynamic rating to the bearing equivalent load.

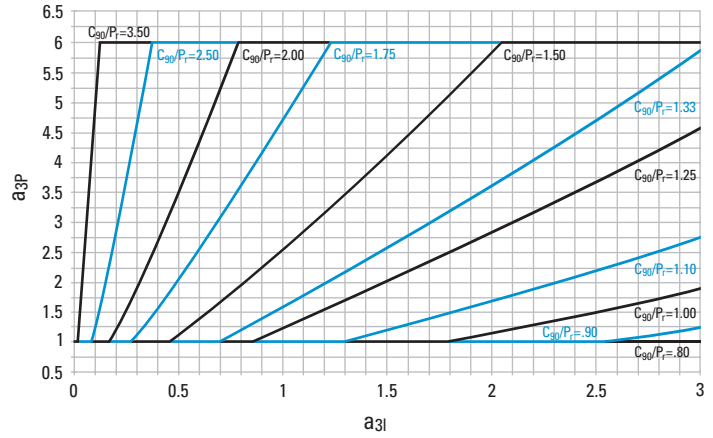

Fig. A-9. Low-load factor (a_{3p}) vs. lubricant life factor (a_{3l}) and C_{90}/P_1 ratio

APPLIED DYNAMIC LOAD

Maximum Bearing Load

When the applied load is greater than one-third of the basic dynamic load rating, the above load-life relationship is no longer valid. Therefore, for most applications, it should be the maximum load applied on a bearing when calculating the basic rating life.

Equivalent Bearing Load Under Variable Loads and Speeds

When a bearing constant is subjected to varying loads and speeds, the equivalent (constant) load (P) on the bearing can be determined using the following formula:

$$P = \left(\frac{P_1^{10/3} \times n_1 \times t_1 + P_2^{10/3} \times n_2 \times t_2 + P_3^{10/3} \times n_3 \times t_3 + \dots}{N} \right)^{3/10}$$

Where P_1 , P_2 , and P_3 represent loads acting at speeds n_1 , n_2 and n_3 and t_1 , t_2 and t_3 represent the decimal portion of the total time that P_1 is acting at n_1 , P_2 is acting at n_2 and P_3 is acting at n_3 . The weighted $\text{min}^{-1} N$ is the numerical summation of $t_1 n_1$ plus $t_2 n_2$ plus ... $t_n n_n$.

Equivalent Bearing Load Under Variable Loads, but Constant Speed

$$P = (P_1^{10/3} \times t_1 + P_2^{10/3} \times t_2 + \dots)^{3/10}$$

SYSTEM LIFE AND WEIGHTED AVERAGE LIFE

SYSTEM LIFE

System reliability is the probability that all of several bearings in a system will attain or exceed some required life. Systems reliability is the product of the individual bearing reliabilities in the system:

$$R_{(\text{system})} = R_A R_B R_C \dots R_n$$

In an application, the L_{10} system life for a number of bearings each having a different L_{10} life is:

$$L_{10(\text{system})} = \left[\left(\frac{1}{L_{10A}} \right)^{3/2} + \left(\frac{1}{L_{10B}} \right)^{3/2} + \dots + \left(\frac{1}{L_{10n}} \right)^{3/2} \right]^{-2/3}$$

WEIGHTED AVERAGE LIFE

To allow for varying lubrication conditions in a load cycle it is necessary to perform the weighted average life calculation:

Weighted average life:

$$L_{10wt} = \frac{1}{\frac{T_1}{(L_{10})_1} + \frac{T_2}{(L_{10})_2} + \dots + \frac{T_n}{(L_{10})_n}}$$

Where, during a load cycle:

T = Proportion of total time

L_{10} = Calculated L_{10} bearing life for each condition

TOLERANCES OF NEEDLE ROLLER BEARINGS

The tolerances given in the following table apply to inner rings of metric series needle roller radial bearing types in which their rings are precision-finished.

TOLERANCE TERMS, SYMBOLS AND DEFINITIONS
Axes, planes etc.

Inner ring (or shaft washer) axis: Axis of the cylinder inscribed in a basically cylindrical bore. The inner ring (or shaft washer) axis also is the bearing axis.

Outer ring (or housing washer) axis: Axis of the cylinder circumscribed around a basically cylindrical outside surface.

Radial plane: Plane perpendicular to the bearing or ring axis. It is, however, acceptable to consider radial planes referred to in the definitions as being parallel with the plane tangential to the reference face of a ring or the back face of a thrust bearing washer.

Radial direction: Direction through the bearing or ring axis in a radial plane.

Axial plane: Plane containing the bearing or ring axis.

Axial direction: Direction parallel with the bearing or ring axis. It is, however, acceptable to consider axial directions referred to in the definitions as being perpendicular to the plane tangential to the reference face of a ring or back face of a thrust bearing washer.

Reference face: Face designated by the manufacturer of the bearings and which may be the datum for measurements.

The reference face for measurement is generally taken as the unmarked face. In case of symmetrical rings, when it is not possible to identify the reference face, the tolerances are deemed to comply relative to either face, but not both. The reference face of a shaft and housing washer as a thrust bearing is that face intended to support axial load and is generally opposite the raceway face.

Outer ring flange back face: That side of an outer ring flange which is intended to support axial load.

Middle of raceway: Point or line on a raceway surface, halfway between the two edges of the raceway.

Raceway contact diameter: Diameter of the theoretical circle through the nominal points of contact between the rolling elements and raceway.

NOTE: For roller bearings, the nominal point of contact is generally at the middle of the roller.

Diameter deviation near ring faces: In radial planes, nearer the face of a ring than 1.2 times the maximum (axial direction) ring chamfer, only the maximum material limits apply.

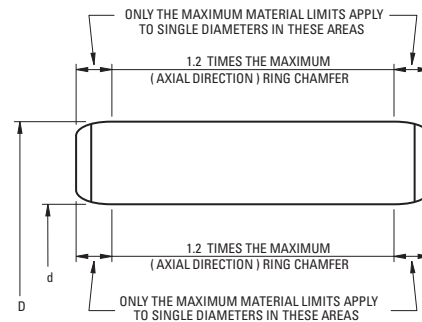

ABMA / ISO Symbols - Inner Ring

- Δd_{mp} Single plane mean bore diameter deviation from basic bore diameter, e.g., bore tolerance for a basically tapered bore, Δd_{mp} refers only to the theoretical small bore end of the bore.
- V_{dsp} Difference between the largest and the smallest of the single bore diameters in a single radial plane.
- V_{dmp} Difference between the largest and smallest of the mean bore diameters in a single radial plane of an individual ring.

ABMA / ISO Symbols - Outer Ring

- ΔD_{mp} Single plane mean outside diameter deviation from basic outside diameter, e.g., O.D. tolerance.
- V_{Dsp} Difference between the largest and smallest of the single outside diameters in a single radial plane.

The following tables provide standard ISO tolerance information. They are provided for general use and are referenced throughout this catalog.

ISO Tolerances for Holes – Metric													
Diameters mm		Deviations mm						Deviations mm					
>	≤	B10		B11		B12		C9		C10		C11	
		Max.	Min.	Max.	Min.	Max.	Min.	Max.	Min.	Max.	Min.	Max.	Min.
3	6	0.188	0.140	0.215	0.140	0.260	0.140	0.100	0.070	0.118	0.070	0.145	0.070
6	10	0.208	0.150	0.240	0.150	0.300	0.150	0.116	0.080	0.138	0.080	0.170	0.080
10	18	0.220	0.150	0.260	0.150	0.330	0.150	0.138	0.095	0.165	0.095	0.205	0.095
18	30	0.244	0.160	0.290	0.160	0.370	0.160	0.162	0.110	0.194	0.110	0.240	0.110
30	40	0.270	0.170	0.330	0.170	0.420	0.170	0.182	0.120	0.220	0.120	0.280	0.120
40	50	0.280	0.180	0.340	0.180	0.430	0.180	0.192	0.130	0.230	0.130	0.290	0.130
50	65	0.310	0.190	0.380	0.190	0.490	0.190	0.214	0.140	0.260	0.140	0.330	0.140
65	80	0.320	0.200	0.390	0.200	0.500	0.200	0.224	0.150	0.270	0.150	0.340	0.150
80	100	0.360	0.220	0.440	0.220	0.570	0.220	0.257	0.170	0.310	0.170	0.390	0.170
100	120	0.380	0.240	0.460	0.240	0.590	0.240	0.267	0.180	0.320	0.180	0.400	0.180
120	140	0.420	0.260	0.510	0.260	0.660	0.260	0.300	0.200	0.360	0.200	0.450	0.200
140	160	0.440	0.280	0.530	0.280	0.680	0.280	0.310	0.210	0.370	0.210	0.460	0.210
160	180	0.470	0.310	0.560	0.310	0.710	0.310	0.330	0.230	0.390	0.230	0.480	0.230
180	200	0.525	0.340	0.630	0.340	0.800	0.340	0.355	0.240	0.425	0.240	0.530	0.240
200	225	0.565	0.380	0.670	0.380	0.840	0.380	0.375	0.260	0.445	0.260	0.550	0.260
225	250	0.605	0.420	0.710	0.420	0.880	0.420	0.395	0.280	0.465	0.280	0.570	0.280
250	280	0.690	0.480	0.800	0.480	1.000	0.480	0.430	0.300	0.510	0.300	0.620	0.300
280	315	0.750	0.540	0.860	0.540	1.060	0.540	0.460	0.330	0.540	0.330	0.650	0.330
315	355	0.830	0.600	0.960	0.600	1.170	0.600	0.500	0.360	0.590	0.360	0.720	0.360
355	400	0.910	0.680	1.040	0.680	1.250	0.680	0.540	0.400	0.630	0.400	0.760	0.400
400	450	1.010	0.760	1.160	0.760	1.390	0.760	0.595	0.440	0.690	0.440	0.840	0.440
450	500	1.090	0.840	1.240	0.840	1.470	0.840	0.635	0.480	0.730	0.480	0.880	0.480

Diameters mm		Deviations mm									
>	≤	E9		E10		E11		E12		E13	
		Max.	Min.	Max.	Min.	Max.	Min.	Max.	Min.	Max.	Min.
3	6	0.050	0.020	0.068	0.020	0.095	0.020	0.140	0.020	0.200	0.020
6	10	0.061	0.025	0.083	0.025	0.115	0.025	0.175	0.025	0.245	0.025
10	18	0.075	0.032	0.102	0.032	0.142	0.032	0.212	0.032	0.302	0.032
18	30	0.092	0.040	0.124	0.040	0.170	0.040	0.250	0.040	0.370	0.040
30	50	0.112	0.050	0.150	0.050	0.210	0.050	0.300	0.050	0.440	0.050
50	80	0.134	0.060	0.180	0.060	0.250	0.060	0.360	0.060	0.520	0.060
80	120	0.159	0.072	0.212	0.072	0.292	0.072	0.422	0.072	0.612	0.072
120	180	0.185	0.085	0.245	0.085	0.335	0.085	0.485	0.085	0.715	0.085
180	250	0.215	0.100	0.285	0.100	0.390	0.100	0.560	0.100	0.820	0.100
250	315	0.240	0.110	0.320	0.110	0.430	0.110	0.630	0.110	0.920	0.110
315	400	0.265	0.125	0.355	0.125	0.485	0.125	0.695	0.125	1.015	0.125
400	500	0.290	0.135	0.385	0.135	0.535	0.135	0.765	0.135	1.105	0.135

Diameters mm		Deviations mm							
>	≤	F5		F6		F7		F8	
		Max.	Min.	Max.	Min.	Max.	Min.	Max.	Min.
3	6	0.015	0.010	0.018	0.010	0.022	0.010	0.028	0.010
6	10	0.019	0.013	0.022	0.013	0.028	0.013	0.035	0.013
10	18	0.024	0.016	0.027	0.016	0.034	0.016	0.043	0.016
18	30	0.029	0.020	0.033	0.020	0.041	0.020	0.053	0.020
30	50	0.036	0.025	0.041	0.025	0.050	0.025	0.064	0.025
50	80	0.043	0.030	0.049	0.030	0.060	0.030	0.076	0.030
80	120	0.051	0.036	0.058	0.036	0.071	0.036	0.090	0.036
120	180	0.061	0.043	0.068	0.043	0.083	0.043	0.106	0.043
180	250	0.070	0.050	0.079	0.050	0.096	0.050	0.122	0.050
250	315	0.079	0.056	0.088	0.056	0.108	0.056	0.137	0.056
315	400	0.087	0.062	0.098	0.062	0.119	0.062	0.151	0.062
400	500	0.095	0.068	0.108	0.068	0.131	0.068	0.165	0.068

ISO Tolerances for Holes – Metric

Diameter mm		Deviations mm					
>	≤	G5		G6		G7	
		Max.	Min.	Max.	Min.	Max.	Min.
3	6	0.009	0.004	0.012	0.004	0.016	0.004
6	10	0.011	0.005	0.014	0.005	0.020	0.005
10	18	0.014	0.006	0.017	0.006	0.024	0.006
18	30	0.016	0.007	0.020	0.007	0.028	0.007
30	50	0.020	0.009	0.025	0.009	0.034	0.009
50	80	0.023	0.010	0.029	0.010	0.040	0.010
80	120	0.027	0.012	0.034	0.012	0.047	0.012
120	180	0.032	0.014	0.039	0.014	0.054	0.014
180	250	0.035	0.015	0.044	0.015	0.061	0.015
250	315	0.040	0.017	0.049	0.017	0.069	0.017
315	400	0.043	0.018	0.054	0.018	0.075	0.018
400	500	0.047	0.020	0.060	0.020	0.083	0.020

Diameters mm		Deviations mm									
>	≤	H4		H5		H6		H7		H8	
		Max.	Min.	Max.	Min.	Max.	Min.	Max.	Min.	Max.	Min.
3	6	0.004	0.000	0.005	0.000	0.008	0.000	0.012	0.000	0.018	0.000
6	10	0.004	0.000	0.006	0.000	0.009	0.000	0.015	0.000	0.022	0.000
10	18	0.005	0.000	0.008	0.000	0.011	0.000	0.018	0.000	0.027	0.000
18	30	0.006	0.000	0.009	0.000	0.013	0.000	0.021	0.000	0.033	0.000
30	50	0.007	0.000	0.011	0.000	0.016	0.000	0.025	0.000	0.039	0.000
50	80	0.008	0.000	0.013	0.000	0.019	0.000	0.030	0.000	0.046	0.000
80	120	0.010	0.000	0.015	0.000	0.022	0.000	0.035	0.000	0.054	0.000
120	180	0.012	0.000	0.018	0.000	0.025	0.000	0.040	0.000	0.063	0.000
180	250	0.014	0.000	0.020	0.000	0.029	0.000	0.046	0.000	0.072	0.000
250	315	0.016	0.000	0.023	0.000	0.032	0.000	0.052	0.000	0.081	0.000
315	400	0.018	0.000	0.025	0.000	0.036	0.000	0.057	0.000	0.089	0.000
400	500	0.020	0.000	0.027	0.000	0.040	0.000	0.063	0.000	0.097	0.000

Diameters mm		Deviations mm							
>	≤	H9		H10		H11		H12	
		Max.	Min.	Max.	Min.	Max.	Min.	Max.	Min.
3	6	0.030	0.000	0.048	0.000	0.075	0.000	0.120	0.000
6	10	0.036	0.000	0.058	0.000	0.090	0.000	0.150	0.000
10	18	0.043	0.000	0.070	0.000	0.110	0.000	0.180	0.000
18	30	0.052	0.000	0.084	0.000	0.130	0.000	0.210	0.000
30	50	0.062	0.000	0.100	0.000	0.160	0.000	0.250	0.000
50	80	0.074	0.000	0.120	0.000	0.190	0.000	0.300	0.000
80	120	0.087	0.000	0.140	0.000	0.220	0.000	0.350	0.000
120	180	0.100	0.000	0.160	0.000	0.250	0.000	0.400	0.000
180	250	0.115	0.000	0.185	0.000	0.290	0.000	0.460	0.000
250	315	0.130	0.000	0.210	0.000	0.320	0.000	0.520	0.000
315	400	0.140	0.000	0.230	0.000	0.360	0.000	0.570	0.000
400	500	0.155	0.000	0.250	0.000	0.400	0.000	0.630	0.000

ISO Tolerances for Holes – Metric													
Diameters mm		Deviations mm						Deviations mm					
>	≤	J6		J7		J8		K6		K7		K8	
		Max.	Min.	Max.	Min.	Max.	Min.	Max.	Min.	Max.	Min.	Max.	Min.
3	6	0.005	-0.003	0.006	-0.006	0.010	-0.008	0.002	-0.006	0.003	-0.009	0.005	-0.013
6	10	0.005	-0.004	0.008	-0.007	0.012	-0.010	0.002	-0.007	0.005	-0.010	0.006	-0.016
10	18	0.006	-0.005	0.010	-0.008	0.015	-0.012	0.002	-0.009	0.006	-0.012	0.008	-0.019
18	30	0.008	-0.005	0.012	-0.009	0.020	-0.013	0.002	-0.011	0.006	-0.015	0.010	-0.023
30	50	0.010	-0.006	0.014	-0.011	0.024	-0.015	0.003	-0.013	0.007	-0.018	0.012	-0.027
50	80	0.013	-0.006	0.018	-0.012	0.028	-0.018	0.004	-0.015	0.009	-0.021	0.014	-0.032
80	120	0.016	-0.006	0.022	-0.013	0.034	-0.020	0.004	-0.018	0.010	-0.025	0.016	-0.038
120	180	0.018	-0.007	0.026	-0.014	0.041	-0.022	0.004	-0.021	0.012	-0.028	0.020	-0.043
180	250	0.022	-0.007	0.030	-0.016	0.047	-0.025	0.005	-0.024	0.013	-0.033	0.022	-0.050
250	315	0.025	-0.007	0.036	-0.016	0.055	-0.026	0.005	-0.027	0.016	-0.036	0.025	-0.056
315	400	0.029	-0.007	0.039	-0.018	0.060	-0.029	0.007	-0.029	0.017	-0.040	0.028	-0.061
400	500	0.033	-0.007	0.043	-0.020	0.066	-0.031	0.008	-0.032	0.018	-0.045	0.029	-0.068

ISO Tolerances for Holes – Metric													
Diameters mm		Deviations mm						Deviations mm					
>	≤	M5		M6		M7		N6		N7		N8	
		Max.	Min.	Max.	Min.	Max.	Min.	Max.	Min.	Max.	Min.	Max.	Min.
3	6	-0.003	-0.008	-0.001	-0.009	0.000	-0.012	-0.005	-0.013	-0.004	-0.016	-0.002	-0.020
6	10	-0.004	-0.010	-0.003	-0.012	0.000	-0.015	-0.007	-0.016	-0.004	-0.019	-0.003	-0.025
10	18	-0.004	-0.012	-0.004	-0.015	0.000	-0.018	-0.009	-0.020	-0.005	-0.023	-0.003	-0.030
18	30	-0.005	-0.014	-0.004	-0.017	0.000	-0.021	-0.011	-0.024	-0.007	-0.028	-0.003	-0.036
30	50	-0.005	-0.016	-0.004	-0.020	0.000	-0.025	-0.012	-0.028	-0.008	-0.033	-0.003	-0.042
50	80	-0.006	-0.019	-0.005	-0.024	0.000	-0.030	-0.014	-0.033	-0.009	-0.039	-0.004	-0.050
80	120	-0.008	-0.023	-0.006	-0.028	0.000	-0.035	-0.016	-0.038	-0.010	-0.045	-0.004	-0.058
120	180	-0.009	-0.027	-0.008	-0.033	0.000	-0.040	-0.020	-0.045	-0.012	-0.052	-0.004	-0.067
180	250	-0.011	-0.031	-0.008	-0.037	0.000	-0.046	-0.022	-0.051	-0.014	-0.060	-0.005	-0.077
250	315	-0.013	-0.036	-0.009	-0.041	0.000	-0.052	-0.025	-0.057	-0.014	-0.066	-0.005	-0.086
315	400	-0.014	-0.039	-0.010	-0.046	0.000	-0.057	-0.026	-0.062	-0.016	-0.073	-0.005	-0.094
400	500	-0.016	-0.043	-0.010	-0.050	0.000	-0.063	-0.027	-0.067	-0.017	-0.080	-0.006	-0.103

ISO Tolerances for Holes – Metric													
Diameters mm		Deviations mm						Deviations mm					
>	≤	P6		P7		R6		R7		R8		Max.	Min.
		Max.	Min.	Max.	Min.	Max.	Min.	Max.	Min.	Max.	Min.		
3	6	-0.009	-0.017	-0.008	-0.020	-0.012	-0.020	-0.011	-0.023	-0.015	-0.033		
6	10	-0.012	-0.021	-0.009	-0.024	-0.016	-0.025	-0.013	-0.028	-0.019	-0.041		
10	18	-0.015	-0.026	-0.011	-0.029	-0.020	-0.031	-0.016	-0.034	-0.023	-0.050		
18	30	-0.018	-0.031	-0.014	-0.035	-0.024	-0.037	-0.020	-0.041	-0.028	-0.061		
30	50	-0.021	-0.037	-0.017	-0.042	-0.029	-0.045	-0.025	-0.050	-0.034	-0.073		
50	65	-0.026	-0.045	-0.021	-0.051	-0.035	-0.054	-0.030	-0.060	-0.041	-0.087		
65	80	-0.026	-0.045	-0.021	-0.051	-0.037	-0.056	-0.032	-0.062	-0.043	-0.089		
80	100	-0.030	-0.052	-0.024	-0.059	-0.044	-0.066	-0.038	-0.073	-0.051	-0.105		
100	120	-0.030	-0.052	-0.024	-0.059	-0.047	-0.069	-0.041	-0.076	-0.054	-0.108		
120	140	-0.037	-0.061	-0.028	-0.068	-0.056	-0.081	-0.048	-0.088	-0.063	-0.126		
140	160	-0.036	-0.061	-0.028	-0.068	-0.058	-0.083	-0.050	-0.090	-0.065	-0.128		
160	180	-0.036	-0.061	-0.028	-0.068	-0.061	-0.086	-0.053	-0.093	-0.068	-0.131		
180	200	-0.041	-0.070	-0.033	-0.079	-0.068	-0.097	-0.060	-0.106	-0.077	-0.149		
200	225	-0.041	-0.070	-0.033	-0.079	-0.071	-0.100	-0.063	-0.109	-0.080	-0.152		
225	250	-0.041	-0.070	-0.033	-0.079	-0.075	-0.104	-0.067	-0.113	-0.084	-0.156		
250	280	-0.047	-0.079	-0.036	-0.088	-0.085	-0.117	-0.074	-0.126	-0.094	-0.175		
280	315	-0.047	-0.079	-0.036	-0.088	-0.089	-0.121	-0.078	-0.130	-0.098	-0.179		
315	355	-0.051	-0.087	-0.041	-0.098	-0.097	-0.133	-0.087	-0.144	-0.108	-0.197		
355	400	-0.051	-0.087	-0.041	-0.098	-0.103	-0.139	-0.093	-0.150	-0.114	-0.203		
400	450	-0.055	-0.095	-0.045	-0.108	-0.113	-0.153	-0.103	-0.166	-0.126	-0.223		
450	500	-0.055	-0.095	-0.045	-0.108	-0.119	-0.159	-0.109	-0.172	-0.132	-0.229		

ISO Tolerances for Shafts – Metric

Diameters mm		Deviations mm							
>	≤	a10		a11		a12		a13	
		Max.	Min.	Max.	Min.	Max.	Min.	Max.	Min.
—	3	-0.270	-0.310	-0.270	-0.330	-0.270	-0.370	-0.270	-0.410
3	6	-0.270	-0.318	-0.270	-0.345	-0.270	-0.390	-0.270	-0.450
6	10	-0.280	-0.338	-0.280	-0.370	-0.280	-0.430	-0.280	-0.500
10	18	-0.290	-0.360	-0.290	-0.400	-0.290	-0.470	-0.290	-0.560
18	30	-0.300	-0.384	-0.300	-0.430	-0.300	-0.510	-0.300	-0.630
30	40	-0.310	-0.410	-0.310	-0.470	-0.310	-0.560	-0.310	-0.700
40	50	-0.320	-0.420	-0.320	-0.480	-0.320	-0.570	-0.320	-0.710
50	65	-0.340	-0.460	-0.340	-0.530	-0.340	-0.640	-0.340	-0.800
65	80	-0.360	-0.480	-0.360	-0.550	-0.360	-0.660	-0.360	-0.820
80	100	-0.380	-0.520	-0.380	-0.600	-0.380	-0.730	-0.380	-0.920
100	120	-0.410	-0.550	-0.410	-0.630	-0.410	-0.760	-0.410	-0.950
120	140	-0.460	-0.620	-0.460	-0.710	-0.460	-0.860	-0.460	-1.090
140	160	-0.520	-0.680	-0.520	-0.770	-0.520	-0.920	-0.520	-1.150
160	180	-0.580	-0.740	-0.580	-0.830	-0.580	-0.980	-0.580	-1.210
180	200	-0.660	-0.845	-0.660	-0.950	-0.660	-1.120	-0.660	-1.380
200	225	-0.740	-0.925	-0.740	-1.030	-0.740	-1.200	-0.740	-1.460
225	250	-0.820	-1.005	-0.820	-1.110	-0.820	-1.280	-0.820	-1.540
250	280	-0.920	-1.130	-0.920	-1.240	-0.920	-1.440	-0.920	-1.730
280	315	-1.050	-1.260	-1.050	-1.370	-1.050	-1.570	-1.050	-1.860
315	355	-1.200	-1.430	-1.200	-1.560	-1.200	-1.770	-1.200	-2.090
355	400	-1.350	-1.580	-1.350	-1.710	-1.350	-1.920	-1.350	-2.240

Diameters mm		Deviations mm						Deviations mm					
>	≤	c11		c12		c13		e11		e12		e13	
		Max.	Min.	Max.	Min.	Max.	Min.	Max.	Min.	Max.	Min.	Max.	Min.
—	3	-0.060	-0.120	-0.060	-0.160	-0.060	-0.200	-0.014	-0.074	-0.014	-0.114	-0.014	-0.154
3	6	-0.070	-0.145	-0.070	-0.190	-0.070	-0.250	-0.020	-0.095	-0.020	-0.140	-0.020	-0.200
6	10	-0.080	-0.170	-0.080	-0.230	-0.080	-0.300	-0.025	-0.115	-0.025	-0.175	-0.025	-0.245
10	18	-0.095	-0.205	-0.095	-0.275	-0.095	-0.365	-0.032	-0.142	-0.032	-0.212	-0.032	-0.302
18	30	-0.110	-0.240	-0.110	-0.320	-0.110	-0.440	-0.040	-0.170	-0.040	-0.250	-0.040	-0.370
30	40	-0.120	-0.280	-0.120	-0.370	-0.120	-0.510	-0.050	-0.210	-0.050	-0.300	-0.050	-0.440
40	50	-0.130	-0.290	-0.130	-0.380	-0.130	-0.520	-0.050	-0.210	-0.050	-0.300	-0.050	-0.440
50	65	-0.140	-0.330	-0.140	-0.440	-0.140	-0.600	-0.060	-0.250	-0.060	-0.360	-0.060	-0.520
65	80	-0.150	-0.340	-0.150	-0.450	-0.150	-0.610	-0.060	-0.250	-0.060	-0.360	-0.060	-0.520
80	100	-0.170	-0.390	-0.170	-0.520	-0.170	-0.710	-0.072	-0.292	-0.072	-0.422	-0.072	-0.612
100	120	-0.180	-0.400	-0.180	-0.530	-0.180	-0.720	-0.072	-0.292	-0.072	-0.422	-0.072	-0.612
120	140	-0.200	-0.450	-0.200	-0.600	-0.200	-0.830	-0.085	-0.335	-0.085	-0.485	-0.085	-0.715
140	160	-0.210	-0.460	-0.210	-0.610	-0.210	-0.840	-0.085	-0.335	-0.085	-0.485	-0.085	-0.715
160	180	-0.230	-0.480	-0.230	-0.630	-0.230	-0.860	-0.085	-0.335	-0.085	-0.485	-0.085	-0.715
180	200	-0.240	-0.530	-0.240	-0.700	-0.240	-0.960	-0.100	-0.390	-0.100	-0.560	-0.100	-0.820
200	225	-0.260	-0.550	-0.260	-0.720	-0.260	-0.980	-0.100	-0.390	-0.100	-0.560	-0.100	-0.820
225	250	-0.280	-0.570	-0.280	-0.740	-0.280	-1.000	-0.100	-0.390	-0.100	-0.560	-0.100	-0.820
250	280	-0.300	-0.620	-0.300	-0.820	-0.300	-1.110	-0.110	-0.430	-0.110	-0.630	-0.110	-0.920
280	315	-0.330	-0.650	-0.330	-0.850	-0.330	-1.140	-0.110	-0.430	-0.110	-0.630	-0.110	-0.920
315	355	-0.360	-0.720	-0.360	-0.930	-0.360	-1.250	-0.125	-0.485	-0.125	-0.695	-0.125	-1.015
355	400	-0.400	-0.760	-0.400	-0.970	-0.400	-1.290	-0.125	-0.485	-0.125	-0.695	-0.125	-1.015

ISO Tolerances for Shafts – Metric

Diameters mm		Deviations mm						Deviations mm					
>	≤	f5		f6		f7		g5		g6		g7	
		Max.	Min.	Max.	Min.	Max.	Min.	Max.	Min.	Max.	Min.	Max.	Min.
—	3	-0.006	-0.010	-0.006	-0.012	-0.006	-0.016	-0.002	-0.006	-0.002	-0.008	-0.002	-0.012
3	6	-0.010	-0.015	-0.010	-0.018	-0.010	-0.022	-0.004	-0.009	-0.004	-0.012	-0.004	-0.016
6	10	-0.013	-0.019	-0.013	-0.022	-0.013	-0.028	-0.005	-0.011	-0.005	-0.014	-0.005	-0.020
10	18	-0.016	-0.024	-0.016	-0.027	-0.016	-0.034	-0.006	-0.014	-0.006	-0.017	-0.006	-0.024
18	30	-0.020	-0.029	-0.020	-0.033	-0.020	-0.041	-0.007	-0.016	-0.007	-0.020	-0.007	-0.028
30	50	-0.025	-0.036	-0.025	-0.041	-0.025	-0.050	-0.009	-0.020	-0.009	-0.025	-0.009	-0.034
50	80	-0.030	-0.043	-0.030	-0.049	-0.030	-0.060	-0.010	-0.023	-0.010	-0.029	-0.010	-0.040
80	120	-0.036	-0.051	-0.036	-0.058	-0.036	-0.071	-0.012	-0.027	-0.012	-0.034	-0.012	-0.047
120	180	-0.043	-0.061	-0.043	-0.068	-0.043	-0.083	-0.014	-0.032	-0.014	-0.039	-0.014	-0.054
180	250	-0.050	-0.070	-0.050	-0.079	-0.050	-0.096	-0.015	-0.035	-0.015	-0.044	-0.015	-0.061
250	315	-0.056	-0.079	-0.056	-0.088	-0.056	-0.108	-0.017	-0.040	-0.017	-0.049	-0.017	-0.069
315	400	-0.062	-0.087	-0.062	-0.098	-0.062	-0.119	-0.018	-0.043	-0.018	-0.054	-0.018	-0.075

Diameters mm		Deviations mm									
>	≤	h4		h5		h6		h7		h8	
		Max.	Min.	Max.	Min.	Max.	Min.	Max.	Min.	Max.	Min.
—	3	0.000	-0.003	0.000	-0.004	0.000	-0.006	0.000	-0.010	0.000	-0.014
3	6	0.000	-0.004	0.000	-0.005	0.000	-0.008	0.000	-0.012	0.000	-0.018
6	10	0.000	-0.004	0.000	-0.006	0.000	-0.009	0.000	-0.015	0.000	-0.022
10	18	0.000	-0.005	0.000	-0.008	0.000	-0.011	0.000	-0.018	0.000	-0.027
18	30	0.000	-0.006	0.000	-0.009	0.000	-0.013	0.000	-0.021	0.000	-0.033
30	50	0.000	-0.007	0.000	-0.011	0.000	-0.016	0.000	-0.025	0.000	-0.039
50	80	0.000	-0.008	0.000	-0.013	0.000	-0.019	0.000	-0.030	0.000	-0.046
80	120	0.000	-0.010	0.000	-0.015	0.000	-0.022	0.000	-0.035	0.000	-0.054
120	180	0.000	-0.012	0.000	-0.018	0.000	-0.025	0.000	-0.040	0.000	-0.063
180	250	0.000	-0.014	0.000	-0.020	0.000	-0.029	0.000	-0.046	0.000	-0.072
250	315	0.000	-0.016	0.000	-0.023	0.000	-0.032	0.000	-0.052	0.000	-0.081
315	400	0.000	-0.018	0.000	-0.025	0.000	-0.036	0.000	-0.057	0.000	-0.089

Diameters mm		Deviations mm									
>	≤	h9		h10		h11		h12		h13	
		Max.	Min.	Max.	Min.	Max.	Min.	Max.	Min.	Max.	Min.
—	3	0.000	-0.025	0.000	-0.040	0.000	-0.060	0.000	-0.100	0.000	-0.140
3	6	0.000	-0.030	0.000	-0.048	0.000	-0.075	0.000	-0.120	0.000	-0.180
6	10	0.000	-0.036	0.000	-0.058	0.000	-0.090	0.000	-0.150	0.000	-0.220
10	18	0.000	-0.043	0.000	-0.070	0.000	-0.110	0.000	-0.180	0.000	-0.270
18	30	0.000	-0.052	0.000	-0.084	0.000	-0.130	0.000	-0.210	0.000	-0.330
30	50	0.000	-0.062	0.000	-0.100	0.000	-0.160	0.000	-0.250	0.000	-0.390
50	80	0.000	-0.074	0.000	-0.120	0.000	-0.190	0.000	-0.300	0.000	-0.460
80	120	0.000	-0.087	0.000	-0.140	0.000	-0.220	0.000	-0.350	0.000	-0.540
120	180	0.000	-0.100	0.000	-0.160	0.000	-0.250	0.000	-0.400	0.000	-0.630
180	250	0.000	-0.115	0.000	-0.185	0.000	-0.290	0.000	-0.460	0.000	-0.720
250	315	0.000	-0.130	0.000	-0.210	0.000	-0.320	0.000	-0.520	0.000	-0.810
315	400	0.000	-0.140	0.000	-0.230	0.000	-0.360	0.000	-0.570	0.000	-0.890

ISO Tolerances for Shafts – Metric

Diameter mm		Deviations mm						Deviations mm					
>	≤	j5		j6		j7		k5		k6		k7	
		Max.	Min.	Max.	Min.	Max.	Min.	Max.	Min.	Max.	Min.	Max.	Min.
—	3	0.002	-0.002	0.004	-0.002	0.006	-0.004	0.004	0.000	0.006	0.000	0.010	0.000
3	6	0.003	-0.002	0.006	-0.002	0.008	-0.004	0.006	0.001	0.009	0.001	0.013	0.001
6	10	0.004	-0.002	0.007	-0.002	0.010	-0.005	0.007	0.001	0.010	0.001	0.016	0.001
10	18	0.005	-0.003	0.008	-0.003	0.012	-0.006	0.009	0.001	0.012	0.001	0.019	0.001
18	30	0.005	-0.004	0.009	-0.004	0.013	-0.008	0.011	0.002	0.015	0.002	0.023	0.002
30	50	0.006	-0.005	0.011	-0.005	0.015	-0.010	0.013	0.002	0.018	0.002	0.027	0.002
50	80	0.006	-0.007	0.012	-0.007	0.018	-0.012	0.015	0.002	0.021	0.002	0.032	0.002
80	120	0.006	-0.009	0.013	-0.009	0.020	-0.015	0.018	0.003	0.025	0.003	0.038	0.003
120	180	0.007	-0.011	0.014	-0.011	0.022	-0.018	0.021	0.003	0.028	0.003	0.043	0.003
180	250	0.007	-0.013	0.016	-0.013	0.025	-0.021	0.024	0.004	0.033	0.004	0.050	0.004
250	315	0.007	-0.016	0.016	-0.016	0.026	-0.026	0.027	0.004	0.036	0.004	0.056	0.004
315	400	0.007	-0.018	0.018	-0.018	0.029	-0.028	0.029	0.004	0.040	0.004	0.061	0.004

Diameter mm		Deviations mm						Deviations mm					
>	≤	m5		m6		m7		n5		n6		n7	
		Max.	Min.	Max.	Min.	Max.	Min.	Max.	Min.	Max.	Min.	Max.	Min.
—	3	0.006	0.002	0.008	0.002	0.012	0.002	0.008	0.004	0.010	0.004	0.014	0.004
3	6	0.009	0.004	0.012	0.004	0.016	0.004	0.013	0.008	0.016	0.008	0.020	0.008
6	10	0.012	0.006	0.015	0.006	0.021	0.006	0.016	0.010	0.019	0.010	0.025	0.010
10	18	0.015	0.007	0.018	0.007	0.025	0.007	0.020	0.012	0.023	0.012	0.030	0.012
18	30	0.017	0.008	0.021	0.008	0.029	0.008	0.024	0.015	0.028	0.015	0.036	0.015
30	50	0.020	0.009	0.025	0.009	0.034	0.009	0.028	0.017	0.033	0.017	0.042	0.017
50	80	0.024	0.011	0.030	0.011	0.041	0.011	0.033	0.020	0.039	0.020	0.050	0.020
80	120	0.028	0.013	0.035	0.013	0.048	0.013	0.038	0.023	0.045	0.023	0.058	0.023
120	180	0.033	0.015	0.040	0.015	0.055	0.015	0.045	0.027	0.052	0.027	0.067	0.027
180	250	0.037	0.017	0.046	0.017	0.063	0.017	0.051	0.031	0.060	0.031	0.077	0.031
250	315	0.043	0.020	0.052	0.020	0.072	0.020	0.057	0.034	0.066	0.034	0.086	0.034
315	400	0.046	0.021	0.057	0.021	0.078	0.021	0.062	0.037	0.073	0.037	0.094	0.037

Diameter mm		Deviations mm					
>	≤	p6		r6		r7	
		Max.	Min.	Max.	Min.	Max.	Min.
80	100	0.059	0.037	-	-	-	-
100	120	0.059	0.037	-	-	-	-
120	140	0.068	0.043	0.090	0.065	-	-
140	160	0.068	0.043	0.090	0.065	-	-
160	180	0.068	0.043	0.090	0.065	-	-
180	200	0.079	0.050	0.106	0.077	-	-
200	225	0.079	0.050	0.109	0.080	0.126	0.080
225	250	0.079	0.050	0.113	0.084	0.130	0.084
250	280	0.088	0.056	0.126	0.094	0.146	0.094
280	315	0.088	0.056	0.130	0.098	0.150	0.098
315	355	0.098	0.062	0.144	0.108	0.165	0.108
355	400	0.098	0.062	0.150	0.114	0.171	0.114
400	450	0.108	0.068	0.166	0.126	0.189	0.126
450	500	0.108	0.068	0.172	0.132	0.195	0.132

ISO Tolerances for Holes – inch													
Diameter in		Deviations in						Deviations in					
>	≤	B10		B11		B12		C9		C10		C11	
		Max.	Min.	Max.	Min.	Max.	Min.	Max.	Min.	Max.	Min.	Max.	Min.
0.1181	0.2362	+0.0074	+0.0055	+0.0085	+0.0055	+0.0102	+0.0055	+0.0039	+0.0028	+0.0046	+0.0028	+0.0057	+0.0028
0.2362	0.3937	+0.0082	+0.0059	+0.0094	+0.0059	+0.0118	+0.0059	+0.0046	+0.0031	+0.0054	+0.0031	+0.0067	+0.0031
0.3937	0.7087	+0.0087	+0.0059	+0.0102	+0.0059	+0.0130	+0.0059	+0.0054	+0.0037	+0.0065	+0.0037	+0.0081	+0.0037
0.7087	1.1811	+0.0096	+0.0063	+0.0114	+0.0063	+0.0146	+0.0063	+0.0064	+0.0043	+0.0076	+0.0043	+0.0094	+0.0043
1.1811	1.5748	+0.0106	+0.0067	+0.0130	+0.0067	+0.0165	+0.0067	+0.0072	+0.0047	+0.0087	+0.0047	+0.0110	+0.0047
1.5748	1.9685	+0.0110	+0.0071	+0.0134	+0.0071	+0.0169	+0.0071	+0.0076	+0.0051	+0.0091	+0.0051	+0.0114	+0.0051
1.9685	2.5591	+0.0122	+0.0075	+0.0150	+0.0075	+0.0193	+0.0075	+0.0084	+0.0055	+0.0102	+0.0055	+0.0120	+0.0055
2.5591	3.1496	+0.0126	+0.0079	+0.0154	+0.0079	+0.0197	+0.0079	+0.0088	+0.0059	+0.0106	+0.0059	+0.0134	+0.0059
3.1496	3.9370	+0.0142	+0.0087	+0.0173	+0.0087	+0.0224	+0.0087	+0.0101	+0.0067	+0.0122	+0.0067	+0.0154	+0.0067
3.9370	4.7244	+0.0150	+0.0094	+0.0181	+0.0094	+0.0232	+0.0094	+0.0105	+0.0071	+0.0126	+0.0071	+0.0157	+0.0071
4.7244	5.5118	+0.0165	+0.0102	+0.0201	+0.0102	+0.0260	+0.0102	+0.0118	+0.0079	+0.0142	+0.0079	+0.0177	+0.0079
5.5118	6.2992	+0.0173	+0.0110	+0.0209	+0.0110	+0.0268	+0.0110	+0.0122	+0.0083	+0.0146	+0.0083	+0.0181	+0.0083
6.2992	7.0866	+0.0185	+0.0122	+0.0220	+0.0122	+0.0280	+0.0122	+0.0130	+0.0091	+0.0154	+0.0091	+0.0189	+0.0091
7.0866	7.8740	+0.0207	+0.0134	+0.0248	+0.0134	+0.0315	+0.0134	+0.0140	+0.0094	+0.0167	+0.0094	+0.0209	+0.0094
7.8740	8.8583	+0.0222	+0.0150	+0.0264	+0.0150	+0.0331	+0.0150	+0.0148	+0.0102	+0.0175	+0.0102	+0.0217	+0.0102
8.8583	9.8425	+0.0238	+0.0165	+0.0280	+0.0165	+0.0346	+0.0165	+0.0156	+0.0110	+0.0183	+0.0110	+0.0224	+0.0110
9.8425	11.0236	+0.0272	+0.0189	+0.0315	+0.0189	+0.0394	+0.0189	+0.0169	+0.0118	+0.0201	+0.0118	+0.0244	+0.0118
11.0236	12.4016	+0.0295	+0.0213	+0.0339	+0.0213	+0.0417	+0.0213	+0.0181	+0.0130	+0.0213	+0.0130	+0.0256	+0.0130
12.4016	13.9764	+0.0327	+0.0236	+0.0378	+0.0236	+0.0461	+0.0236	+0.0197	+0.0142	+0.0232	+0.0142	+0.0283	+0.0142
13.9764	15.7480	+0.0358	+0.0268	+0.0409	+0.0268	+0.0492	+0.0268	+0.0213	+0.0157	+0.0248	+0.0157	+0.0299	+0.0157
15.7480	17.7165	+0.0398	+0.0299	+0.0457	+0.0299	+0.0547	+0.0299	+0.0234	+0.0173	+0.0272	+0.0173	+0.0331	+0.0173
17.7165	19.6850	+0.0429	+0.0331	+0.0488	+0.0331	+0.0579	+0.0331	+0.0250	+0.0189	+0.0287	+0.0189	+0.0346	+0.0189

Diameter in		Deviations in									
>	≤	E9		E10		E11		E12		E13	
		Max.	Min.	Max.	Min.	Max.	Min.	Max.	Min.	Max.	Min.
0.1181	0.2362	+0.0020	+0.0008	+0.0027	+0.0008	+0.0037	+0.0008	+0.0055	+0.0008	+0.0079	+0.0008
0.2362	0.3937	+0.0024	+0.0010	+0.0033	+0.0010	+0.0045	+0.0010	+0.0069	+0.0010	+0.0096	+0.0010
0.3937	0.7087	+0.0030	+0.0013	+0.0040	+0.0013	+0.0056	+0.0013	+0.0083	+0.0013	+0.0119	+0.0013
0.7087	1.1811	+0.0036	+0.0016	+0.0049	+0.0016	+0.0067	+0.0016	+0.0098	+0.0016	+0.0146	+0.0016
1.1811	1.9685	+0.0044	+0.0020	+0.0059	+0.0020	+0.0083	+0.0020	+0.0118	+0.0020	+0.0173	+0.0020
1.9685	3.1496	+0.0053	+0.0024	+0.0071	+0.0024	+0.0098	+0.0024	+0.0142	+0.0024	+0.0205	+0.0024
3.1496	4.7244	+0.0063	+0.0028	+0.0083	+0.0028	+0.0115	+0.0028	+0.0166	+0.0028	+0.0241	+0.0028
4.7244	7.0866	+0.0073	+0.0033	+0.0096	+0.0033	+0.0132	+0.0033	+0.0191	+0.0033	+0.0281	+0.0033
7.0866	9.8425	+0.0085	+0.0039	+0.0112	+0.0039	+0.0154	+0.0039	+0.0220	+0.0039	+0.0323	+0.0039
9.8425	12.4016	+0.0094	+0.0043	+0.0126	+0.0043	+0.0169	+0.0043	+0.0248	+0.0043	+0.0362	+0.0043
12.4016	15.7480	+0.0104	+0.0049	+0.0140	+0.0049	+0.0191	+0.0049	+0.0274	+0.0049	+0.0400	+0.0049
15.7480	19.6850	+0.0114	+0.0053	+0.0152	+0.0053	+0.0211	+0.0053	+0.0301	+0.0053	+0.0435	+0.0053

Diameter in		Deviations in							
>	≤	F5		F6		F7		F8	
		Max.	Min.	Max.	Min.	Max.	Min.	Max.	Min.
0.1181	0.2362	+0.0006	+0.0004	+0.0007	+0.0004	+0.0009	+0.0004	+0.0011	+0.0004
0.2362	0.3937	+0.0007	+0.0005	+0.0009	+0.0005	+0.0011	+0.0005	+0.0014	+0.0005
0.3937	0.7087	+0.0009	+0.0006	+0.0011	+0.0006	+0.0013	+0.0006	+0.0017	+0.0006
0.7087	1.1811	+0.0011	+0.0008	+0.0013	+0.0008	+0.0016	+0.0008	+0.0021	+0.0008
1.1811	1.9685	+0.0014	+0.0010	+0.0016	+0.0010	+0.0020	+0.0010	+0.0025	+0.0010
1.9685	3.1496	+0.0017	+0.0012	+0.0019	+0.0012	+0.0024	+0.0012	+0.0030	+0.0012
3.1496	4.7244	+0.0020	+0.0014	+0.0023	+0.0014	+0.0028	+0.0014	+0.0035	+0.0014
4.7244	7.0866	+0.0024	+0.0017	+0.0027	+0.0017	+0.0033	+0.0017	+0.0042	+0.0017
7.0866	9.8425	+0.0028	+0.0020	+0.0031	+0.0020	+0.0038	+0.0020	+0.0048	+0.0020
9.8425	12.4016	+0.0031	+0.0022	+0.0035	+0.0022	+0.0043	+0.0022	+0.0054	+0.0022
12.4016	15.7480	+0.0034	+0.0024	+0.0039	+0.0024	+0.0047	+0.0024	+0.0059	+0.0024
15.7480	19.6850	+0.0037	+0.0027	+0.0043	+0.0027	+0.0052	+0.0027	+0.0065	+0.0027

ISO Tolerances for Holes – inch							
Diameter in		Deviations in					
>	≤	G5		G6		G7	
		Max.	Min.	Max.	Min.	Max.	Min.
0.1181	0.2362	+0.0004	+0.0002	+0.0005	+0.0002	+0.0006	+0.0002
0.2362	0.3937	+0.0004	+0.0002	+0.0006	+0.0002	+0.0008	+0.0002
0.3937	0.7087	+0.0006	+0.0002	+0.0007	+0.0002	+0.0009	+0.0002
0.7087	1.1811	+0.0006	+0.0003	+0.0008	+0.0003	+0.0011	+0.0003
1.1811	1.9685	+0.0008	+0.0004	+0.0010	+0.0004	+0.0013	+0.0004
1.9685	3.1496	+0.0009	+0.0004	+0.0011	+0.0004	+0.0016	+0.0004
3.1496	4.7244	+0.0011	+0.0005	+0.0013	+0.0005	+0.0019	+0.0005
4.7244	7.0866	+0.0013	+0.0006	+0.0015	+0.0006	+0.0021	+0.0006
7.0866	9.8425	+0.0014	+0.0006	+0.0017	+0.0006	+0.0024	+0.0006
9.8425	12.4016	+0.0016	+0.0007	+0.0019	+0.0007	+0.0027	+0.0007
12.4016	15.7480	+0.0017	+0.0007	+0.0021	+0.0007	+0.0030	+0.0007
15.7480	19.6850	+0.0019	+0.0008	+0.0024	+0.0008	+0.0033	+0.0008

Diameter in		Deviations in									
>	≤	H4		H5		H6		H7		H8	
		Max.	Min.	Max.	Min.	Max.	Min.	Max.	Min.	Max.	Min.
0.1181	0.2362	+0.0002	0	+0.0002	0	+0.0003	0	+0.0005	0	+0.0007	0
0.2362	0.3937	+0.0002	0	+0.0002	0	+0.0004	0	+0.0006	0	+0.0009	0
0.3937	0.7087	+0.0002	0	+0.0003	0	+0.0004	0	+0.0007	0	+0.0011	0
0.7087	1.1811	+0.0002	0	+0.0004	0	+0.0005	0	+0.0008	0	+0.0013	0
1.1811	1.9685	+0.0003	0	+0.0004	0	+0.0006	0	+0.0010	0	+0.0015	0
1.9685	3.1496	+0.0003	0	+0.0005	0	+0.0007	0	+0.0012	0	+0.0018	0
3.1496	4.7244	+0.0004	0	+0.0006	0	+0.0009	0	+0.0014	0	+0.0021	0
4.7244	7.0866	+0.0005	0	+0.0007	0	+0.0010	0	+0.0016	0	+0.0025	0
7.0866	9.8425	+0.0006	0	+0.0008	0	+0.0011	0	+0.0018	0	+0.0028	0
9.8425	12.4016	+0.0006	0	+0.0009	0	+0.0013	0	+0.0020	0	+0.0032	0
12.4016	15.7480	+0.0007	0	+0.0010	0	+0.0014	0	+0.0022	0	+0.0035	0
15.7480	19.6850	+0.0008	0	+0.0011	0	+0.0016	0	+0.0025	0	+0.0038	0

Diameter in		Deviations in							
>	≤	H9		H10		H11		H12	
		Max.	Min.	Max.	Min.	Max.	Min.	Max.	Min.
0.1181	0.2362	+0.0012	0	+0.0019	0	+0.0030	0	+0.0047	0
0.2362	0.3937	+0.0014	0	+0.0023	0	+0.0035	0	+0.0059	0
0.3937	0.7087	+0.0017	0	+0.0028	0	+0.0043	0	+0.0071	0
0.7087	1.1811	+0.0020	0	+0.0033	0	+0.0051	0	+0.0083	0
1.1811	1.9685	+0.0024	0	+0.0039	0	+0.0063	0	+0.0098	0
1.9685	3.1496	+0.0029	0	+0.0047	0	+0.0075	0	+0.0118	0
3.1496	4.7244	+0.0034	0	+0.0055	0	+0.0087	0	+0.0138	0
4.7244	7.0866	+0.0039	0	+0.0063	0	+0.0098	0	+0.0157	0
7.0866	9.8425	+0.0045	0	+0.0073	0	+0.0114	0	+0.0181	0
9.8425	12.4016	+0.0051	0	+0.0083	0	+0.0126	0	+0.0205	0
12.4016	15.7480	+0.0055	0	+0.0091	0	+0.0142	0	+0.0224	0
15.7480	19.6850	+0.0061	0	+0.0098	0	+0.0157	0	+0.0248	0

ISO Tolerances for Holes – inch													
Diameter in		Deviations in						Deviations in					
>	≤	J6		J7		J8		K6		K7		K8	
		Max.	Min.	Max.	Min.	Max.	Min.	Max.	Min.	Max.	Min.	Max.	Min.
0.1181	0.2362	+0.00020	-0.00012	+0.00024	-0.00024	+0.00039	-0.00031	+0.00008	-0.00024	+0.00012	-0.00035	+0.00020	-0.00051
0.2362	0.3937	+0.00020	-0.00016	+0.00031	-0.00028	+0.00047	-0.00039	+0.00008	-0.00028	+0.00020	-0.00039	+0.00024	-0.00063
0.3937	0.7087	+0.00024	-0.00020	+0.00039	-0.00031	+0.00059	-0.00047	+0.00008	-0.00035	+0.00024	-0.00047	+0.00031	-0.00075
0.7087	1.1811	+0.00031	-0.00020	+0.00047	-0.00035	+0.00079	-0.00051	+0.00008	-0.00043	+0.00024	-0.00059	+0.00039	-0.00091
1.1811	1.9685	+0.00039	-0.00024	+0.00055	-0.00043	+0.00094	-0.00059	+0.00012	-0.00051	+0.00028	-0.00071	+0.00047	-0.00106
1.9685	3.1496	+0.00051	-0.00024	+0.00071	-0.00047	+0.00110	-0.00071	+0.00016	-0.00059	+0.00035	-0.00083	+0.00055	-0.00126
3.1496	4.7244	+0.00063	-0.00024	+0.00087	-0.00051	+0.00134	-0.00079	+0.00016	-0.00071	+0.00039	-0.00098	+0.00063	-0.00150
4.7244	7.0866	+0.00071	-0.00028	+0.00102	-0.00055	+0.00161	-0.00087	+0.00016	-0.00083	+0.00047	-0.00110	+0.00079	-0.00169
7.0866	9.8425	+0.00087	-0.00028	+0.00118	-0.00063	+0.00185	-0.00098	+0.00020	-0.00094	+0.00051	-0.00130	+0.00087	-0.00197
9.8425	12.4016	+0.00098	-0.00028	+0.00142	-0.00063	+0.00217	-0.00102	+0.00020	-0.00106	+0.00063	-0.00142	+0.00098	-0.00220
12.4016	15.7480	+0.00114	-0.00028	+0.00154	-0.00071	+0.00236	-0.00114	+0.00028	-0.00114	+0.00067	-0.00157	+0.00110	-0.00240
15.7480	19.6850	+0.00130	-0.00028	+0.00169	-0.00079	+0.00259	-0.00122	+0.00031	-0.00126	+0.00071	-0.00177	+0.00114	-0.00268

ISO Tolerances for Holes – inch													
Diameter in		Deviations in						Deviations in					
>	≤	M5		M6		M7		N6		N7		N8	
		Max.	Min.	Max.	Min.	Max.	Min.	Max.	Min.	Max.	Min.	Max.	Min.
0.1181	0.2362	-0.00012	-0.00031	-0.00004	-0.00035	0	-0.00047	-0.0002	-0.0005	-0.0002	-0.0006	-0.0001	-0.0008
0.2362	0.3937	-0.00016	-0.00039	-0.00012	-0.00047	0	-0.00059	-0.0003	-0.0006	-0.0002	-0.0007	-0.0001	-0.0010
0.3937	0.7087	-0.00016	-0.00047	-0.00016	-0.00059	0	-0.00071	-0.0004	-0.0008	-0.0002	-0.0009	-0.0001	-0.0012
0.7087	1.1811	-0.00020	-0.00055	-0.00016	-0.00067	0	-0.00083	-0.0004	-0.0009	-0.0003	-0.0011	-0.0001	-0.0014
1.1811	1.9685	-0.00020	-0.00063	-0.00016	-0.00079	0	-0.00098	-0.0005	-0.0011	-0.0003	-0.0013	-0.0001	-0.0017
1.9685	3.1496	-0.00024	-0.00075	-0.00020	-0.00094	0	-0.00118	-0.0006	-0.0013	-0.0004	-0.0015	-0.0002	-0.0020
3.1496	4.7244	-0.00031	-0.00091	-0.00024	-0.00110	0	-0.00138	-0.0006	-0.0015	-0.0004	-0.0018	-0.0002	-0.0023
4.7244	7.0866	-0.00035	-0.00106	-0.00031	-0.00130	0	-0.00157	-0.0008	-0.0018	-0.0005	-0.0020	-0.0002	-0.0026
7.0866	9.8425	-0.00043	-0.00122	-0.00031	-0.00146	0	-0.00181	-0.0009	-0.0020	-0.0006	-0.0024	-0.0002	-0.0030
9.8425	12.4016	-0.00051	-0.00142	-0.00035	-0.00161	0	-0.00205	-0.0000	-0.0022	-0.0006	-0.0026	-0.0002	-0.0034
12.4016	15.7480	-0.00055	-0.00154	-0.00039	-0.00181	0	-0.00224	-0.0010	-0.0024	-0.0006	-0.0029	-0.0002	-0.0037
15.7480	19.6850	-0.00063	-0.00169	-0.00039	-0.00197	0	-0.00248	-0.0011	-0.0026	-0.0007	-0.0031	-0.0002	-0.0041

ISO Tolerances for Holes – inch													
Diameter in		Deviations in						Deviations in					
>	≤	P6		P7		R6		R7		R8			
		Max.	Min.	Max.	Min.	Max.	Min.	Max.	Min.	Max.	Min.		
0.1181	0.2362	-0.0004	-0.0007	-0.0003	-0.0008	-0.0005	-0.0008	-0.0004	-0.0009	-0.0006	-0.0013		
0.2362	0.3937	-0.0005	-0.0008	-0.0004	-0.0009	-0.0006	-0.0010	-0.0005	-0.0011	-0.0007	-0.0016		
0.3937	0.7087	-0.0006	-0.0010	-0.0004	-0.0011	-0.0008	-0.0012	-0.0006	-0.0013	-0.0009	-0.0020		
0.7087	1.1811	-0.0007	-0.0012	-0.0006	-0.0014	-0.0009	-0.0015	-0.0008	-0.0016	-0.0011	-0.0024		
1.1811	1.9685	-0.0008	-0.0015	-0.0007	-0.0017	-0.0011	-0.0018	-0.0010	-0.0020	-0.0013	-0.0029		
1.9685	2.5591	-0.0010	-0.0018	-0.0008	-0.0020	-0.0014	-0.0021	-0.0012	-0.0024	-0.0016	-0.0034		
2.5591	3.1496	-0.0010	-0.0018	-0.0008	-0.0020	-0.0015	-0.0022	-0.0013	-0.0024	-0.0017	-0.0035		
3.1496	3.9370	-0.0012	-0.0020	-0.0009	-0.0023	-0.0017	-0.0026	-0.0015	-0.0029	-0.0020	-0.0041		
3.9370	4.7244	-0.0012	-0.0020	-0.0009	-0.0023	-0.0019	-0.0027	-0.0016	-0.0030	-0.0021	-0.0043		
4.7244	5.5118	-0.0014	-0.0024	-0.0011	-0.0027	-0.0022	-0.0032	-0.0019	-0.0035	-0.0025	-0.0050		
5.5118	6.2992	-0.0014	-0.0024	-0.0011	-0.0027	-0.0023	-0.0033	-0.0020	-0.0035	-0.0026	-0.0050		
6.2992	7.0866	-0.0014	-0.0024	-0.0011	-0.0027	0.0024	-0.0034	-0.0021	-0.0037	-0.0027	-0.0052		
7.0866	7.8740	-0.0016	-0.0028	-0.0013	-0.0031	-0.0027	-0.0038	-0.0024	-0.0042	-0.0030	-0.0059		
7.8740	8.8583	-0.0016	-0.0028	-0.0013	-0.0031	0.0028	-0.0039	-0.0025	-0.0043	-0.0031	-0.0060		
8.8583	9.8425	-0.0016	-0.0028	-0.0013	-0.0031	-0.0030	-0.0041	-0.0026	-0.0044	-0.0033	-0.0061		
9.8425	11.0236	-0.0019	-0.0031	-0.0014	-0.0035	-0.0033	-0.0046	-0.0029	-0.0050	-0.0037	-0.0069		
11.0236	12.4016	-0.0019	-0.0031	-0.0014	-0.0035	-0.0035	-0.0048	-0.0031	-0.0051	-0.0039	-0.0070		
12.4016	13.9764	-0.0020	-0.0034	-0.0016	-0.0039	-0.0038	-0.0052	-0.0034	-0.0057	-0.0043	-0.0078		
13.9764	15.7480	-0.0020	-0.0034	-0.0016	-0.0039	-0.0041	-0.0055	-0.0037	-0.0059	-0.0045	-0.0080		
15.7480	17.7165	-0.0022	-0.0037	-0.0018	-0.0043	-0.0044	-0.0060	-0.0041	-0.0065	-0.0050	-0.0088		
17.7165	19.6850	-0.0022	-0.0037	-0.0018	-0.0043	-0.0047	-0.0063	-0.0043	-0.0068	-0.0052	-0.0090		

ISO Tolerances for Holes – inch									
Diameter in		Deviations in							
>	≤	a10		a11		a12		a13	
		Max.	Min.	Max.	Min.	Max.	Min.	Max.	Min.
—	0.1181	-0.0106	-0.0122	-0.0106	-0.0130	-0.0106	-0.0146	-0.0106	-0.0161
0.1181	0.2362	-0.0106	-0.0125	-0.0106	-0.0136	-0.0106	-0.0154	-0.0106	-0.0177
0.2362	0.3937	-0.0110	-0.0133	-0.0110	-0.0146	-0.0110	-0.0169	-0.0110	-0.0197
0.3937	0.7087	-0.0114	-0.0142	-0.0114	-0.0157	-0.0114	-0.0185	-0.0114	-0.0220
0.7087	1.1811	-0.0118	-0.0151	-0.0118	-0.0169	-0.0118	-0.0201	-0.0118	-0.0248
1.1811	1.5748	-0.0122	-0.0161	-0.0122	-0.0185	-0.0122	-0.0220	-0.0122	-0.0276
1.5748	1.9685	-0.0126	-0.0165	-0.0126	-0.0189	-0.0126	-0.0224	-0.0126	-0.0280
1.9685	2.5591	-0.0134	-0.0181	-0.0134	-0.0209	-0.0134	-0.0252	-0.0134	-0.0315
2.5591	3.1496	-0.0142	-0.0189	-0.0142	-0.0217	-0.0142	-0.0260	-0.0142	-0.0323
3.1496	3.9370	-0.0150	-0.0205	-0.0150	-0.0236	-0.0150	-0.0287	-0.0150	-0.0362
3.9370	4.7244	-0.0161	-0.0217	-0.0161	-0.0248	-0.0161	-0.0299	-0.0161	-0.0374
4.7244	5.5118	-0.0181	-0.0244	-0.0181	-0.0280	-0.0181	-0.0339	-0.0181	-0.0429
5.5118	6.2992	-0.0205	-0.0268	-0.0205	-0.0303	-0.0205	-0.0362	-0.0205	-0.0453
6.2992	7.0866	-0.0228	-0.0291	-0.0228	-0.0327	-0.0228	-0.0386	-0.0228	-0.0476
7.0866	7.8740	-0.0260	-0.0333	-0.0260	-0.0374	-0.0260	-0.0441	-0.0260	-0.0543
7.8740	8.8583	-0.0291	-0.0364	-0.0291	-0.0406	-0.0291	-0.0472	-0.0291	-0.0575
8.8583	9.8425	-0.0323	-0.0396	-0.0323	-0.0437	-0.0323	-0.0504	-0.0323	-0.0606
9.8425	11.0236	-0.0362	-0.0445	-0.0362	-0.0488	-0.0362	-0.0567	-0.0362	-0.0681
11.0236	12.4016	-0.0413	-0.0496	-0.0413	-0.0539	-0.0413	-0.0618	-0.0413	-0.0732
12.4016	13.9764	-0.0472	-0.0563	-0.0472	-0.0614	-0.0472	-0.0697	-0.0472	-0.0823
13.9764	15.7480	-0.0531	-0.0622	-0.0531	-0.0673	-0.0531	-0.0756	-0.0531	-0.0882

Diameter in		Deviations in						Deviations in					
>	≤	c11		c12		c13		e11		e12		e13	
		Max.	Min.	Max.	Min.	Max.	Min.	Max.	Min.	Max.	Min.	Max.	Min.
—	0.1181	-0.0024	-0.0047	-0.0024	-0.0063	-0.0024	-0.0079	-0.0006	-0.0029	-0.0006	-0.0045	-0.0006	-0.0061
0.1181	0.2362	-0.0028	-0.0057	-0.0028	-0.0075	-0.0028	-0.0098	-0.0008	-0.0037	-0.0008	-0.0055	-0.0008	-0.0079
0.2362	0.3937	-0.0031	-0.0067	-0.0031	-0.0091	-0.0031	-0.0118	-0.0010	-0.0045	-0.0010	-0.0069	-0.0010	-0.0096
0.3937	0.7087	-0.0037	-0.0081	-0.0037	-0.0108	-0.0037	-0.0144	-0.0013	-0.0056	-0.0013	-0.0083	-0.0013	-0.0119
0.7087	1.1811	-0.0043	-0.0094	-0.0043	-0.0126	-0.0043	-0.0173	-0.0016	-0.0067	-0.0016	-0.0098	-0.0016	-0.0146
1.1811	1.5748	-0.0047	-0.0110	-0.0047	-0.0146	-0.0047	-0.0201	-0.0020	-0.0083	-0.0020	-0.0118	-0.0020	-0.0173
1.5748	1.9685	-0.0051	-0.0114	-0.0051	-0.0150	-0.0051	-0.0205	-0.0020	-0.0083	-0.0020	-0.0118	-0.0020	-0.0173
1.9685	2.5591	-0.0055	-0.0130	-0.0055	-0.0173	-0.0055	-0.0236	-0.0024	-0.0098	-0.0024	-0.0142	-0.0024	-0.0205
2.5591	3.1496	-0.0059	-0.0134	-0.0059	-0.0177	-0.0059	-0.0240	-0.0024	-0.0098	-0.0024	-0.0142	-0.0024	-0.0205
3.1496	3.9370	-0.0067	-0.0154	-0.0067	-0.0205	-0.0067	-0.0280	-0.0028	-0.0115	-0.0028	-0.0166	-0.0028	-0.0241
3.9370	4.7244	-0.0071	-0.0157	-0.0071	-0.0209	-0.0071	-0.0283	-0.0028	-0.0115	-0.0028	-0.0166	-0.0028	-0.0241
4.7244	5.5118	-0.0079	-0.0177	-0.0079	-0.0236	-0.0079	-0.0327	-0.0033	-0.0132	-0.0033	-0.0191	-0.0033	-0.0281
5.5118	6.2992	-0.0083	-0.0181	-0.0083	-0.0240	-0.0083	-0.0331	-0.0033	-0.0132	-0.0033	-0.0191	-0.0033	-0.0281
6.2992	7.0866	-0.0091	-0.0189	-0.0091	-0.0248	-0.0091	-0.0339	-0.0033	-0.0132	-0.0033	-0.0191	-0.0033	-0.0281
7.0866	7.8740	-0.0094	-0.0209	-0.0094	-0.0276	-0.0094	-0.0378	-0.0039	-0.0154	-0.0039	-0.0220	-0.0039	-0.0323
7.8740	8.8583	-0.0102	-0.0217	-0.0102	-0.0283	-0.0102	-0.0386	-0.0039	-0.0154	-0.0039	-0.0220	-0.0039	-0.0323
8.8583	9.8425	-0.0110	-0.0224	-0.0110	-0.0291	-0.0110	-0.0394	-0.0039	-0.0154	-0.0039	-0.0220	-0.0039	-0.0323
9.8425	11.0236	-0.0118	-0.0244	-0.0118	-0.0323	-0.0118	-0.0437	-0.0043	-0.0169	-0.0043	-0.0248	-0.0043	-0.0362
11.0236	12.4016	-0.0130	-0.0256	-0.0130	-0.0335	-0.0130	-0.0449	-0.0043	-0.0169	-0.0043	-0.0248	-0.0043	-0.0362
12.4016	13.9764	-0.0142	-0.0283	-0.0142	-0.0366	-0.0142	-0.0492	-0.0049	-0.0191	-0.0049	-0.0274	-0.0049	-0.0400
13.9764	15.7480	-0.0157	-0.0299	-0.0157	-0.0382	-0.0157	-0.0508	-0.0049	-0.0191	-0.0049	-0.0274	-0.0049	-0.0400

ISO Tolerances for Shafts – inch													
Diameter in		Deviations in						Deviations in					
>	≤	f5		f6		f7		g5		g6		g7	
		Max.	Min.	Max.	Min.	Max.	Min.	Max.	Min.	Max.	Min.	Max.	Min.
—	0.1181	-0.0002	-0.0004	-0.0002	-0.0005	-0.0002	-0.0006	-0.0001	-0.0002	-0.0001	-0.0003	-0.0001	-0.0005
0.1181	0.2362	-0.0004	-0.0006	-0.0004	-0.0007	-0.0004	-0.0009	-0.0002	-0.0004	-0.0002	-0.0005	-0.0002	-0.0006
0.2362	0.3937	-0.0005	-0.0007	-0.0005	-0.0009	-0.0005	-0.0011	-0.0002	-0.0004	-0.0002	-0.0006	-0.0002	-0.0008
0.3937	0.7087	-0.0006	-0.0009	-0.0006	-0.0011	-0.0006	-0.0013	-0.0002	-0.0006	-0.0002	-0.0007	-0.0002	-0.0009
0.7087	1.1811	-0.0008	-0.0011	-0.0008	-0.0013	-0.0008	-0.0016	-0.0003	-0.0006	-0.0003	-0.0008	-0.0003	-0.0011
1.1811	1.9685	-0.0010	-0.0014	-0.0010	-0.0016	-0.0010	-0.0020	-0.0004	-0.0008	-0.0004	-0.0010	-0.0004	-0.0013
1.9685	3.1496	-0.0012	-0.0017	-0.0012	-0.0019	-0.0012	-0.0024	-0.0004	-0.0009	-0.0004	-0.0011	-0.0004	-0.0016
3.1496	4.7244	-0.0014	-0.0020	-0.0014	-0.0023	-0.0014	-0.0028	-0.0005	-0.0011	-0.0005	-0.0013	-0.0005	-0.0019
4.7244	7.0866	-0.0017	-0.0024	-0.0017	-0.0027	-0.0017	-0.0033	-0.0006	-0.0013	-0.0006	-0.0015	-0.0006	-0.0021
7.0866	9.8425	-0.0020	-0.0028	-0.0020	-0.0031	-0.0020	-0.0038	-0.0006	-0.0014	-0.0006	-0.0017	-0.0006	-0.0024
9.8425	12.4016	-0.0022	-0.0031	-0.0022	-0.0035	-0.0022	-0.0043	-0.0007	-0.0016	-0.0007	-0.0019	-0.0007	-0.0027
12.4016	15.7480	-0.0024	-0.0034	-0.0024	-0.0039	-0.0024	-0.0047	-0.0007	-0.0017	-0.0007	-0.0021	-0.0007	-0.0030

ISO Tolerances for Shafts – inch											
Diameter in		Deviations in									
>	≤	h4		h5		h6		h7		h8	
		Max.	Min.	Max.	Min.	Max.	Min.	Max.	Min.	Max.	Min.
—	0.1181	0	-0.00012	0	-0.00016	0	-0.00024	0	-0.0004	0	-0.0006
0.1181	0.2362	0	-0.00016	0	-0.00020	0	-0.00031	0	-0.0005	0	-0.0007
0.2362	0.3937	0	-0.0002	0	-0.00024	0	-0.0004	0	-0.0006	0	-0.0009
0.3937	0.7087	0	-0.0002	0	-0.00031	0	-0.0004	0	-0.0007	0	-0.0011
0.7087	1.1811	0	-0.0002	0	-0.0004	0	-0.0005	0	-0.0008	0	-0.0013
1.1811	1.9685	0	-0.0003	0	-0.0004	0	-0.0006	0	-0.0010	0	-0.0015
1.9685	3.1496	0	-0.0003	0	-0.0005	0	-0.0007	0	-0.0012	0	-0.0018
3.1496	4.7244	0	-0.0004	0	-0.0006	0	-0.0009	0	-0.0014	0	-0.0021
4.7244	7.0866	0	-0.0005	0	-0.0007	0	-0.0010	0	-0.0016	0	-0.0025
7.0866	9.8425	0	-0.0006	0	-0.0008	0	-0.0011	0	-0.0018	0	-0.0028
9.8425	12.4016	0	-0.0006	0	-0.0009	0	-0.0013	0	-0.0020	0	-0.0032
12.4016	15.7480	0	-0.0007	0	-0.0010	0	-0.0014	0	-0.0022	0	-0.0035

ISO Tolerances for Shafts – inch											
Diameter in		Deviations in									
>	≤	h9		h10		h11		h12		h13	
		Max.	Min.	Max.	Min.	Max.	Min.	Max.	Min.	Max.	Min.
—	0.1181	0	-0.0010	0	-0.0016	0	-0.0024	0	-0.0039	0	-0.0055
0.1181	0.2362	0	-0.0012	0	-0.0019	0	-0.0030	0	-0.0047	0	-0.0071
0.2362	0.3937	0	-0.0014	0	-0.0023	0	-0.0035	0	-0.0059	0	-0.0087
0.3937	0.7087	0	-0.0017	0	-0.0028	0	-0.0043	0	-0.0071	0	-0.0106
0.7087	1.1811	0	-0.0020	0	-0.0033	0	-0.0051	0	-0.0083	0	-0.0130
1.1811	1.9685	0	-0.0024	0	-0.0039	0	-0.0063	0	-0.0098	0	-0.0154
1.9685	3.1496	0	-0.0029	0	-0.0047	0	-0.0075	0	-0.0118	0	-0.0181
3.1496	4.7244	0	-0.0034	0	-0.0055	0	-0.0087	0	-0.0138	0	-0.0213
4.7244	7.0866	0	-0.0039	0	-0.0063	0	-0.0098	0	-0.0157	0	-0.0248
7.0866	9.8425	0	-0.0045	0	-0.0073	0	-0.0114	0	-0.0181	0	-0.0283
9.8425	12.4016	0	-0.0051	0	-0.0083	0	-0.0126	0	-0.0205	0	-0.0319
12.4016	15.7480	0	-0.0055	0	-0.0091	0	-0.0142	0	-0.0224	0	-0.0350

ISO Tolerances for Shafts – inch

Diameter in		Deviations in						Deviations in					
>	≤	j5		j6		j7		k5		k6		k7	
		Max.	Min.	Max.	Min.	Max.	Min.	Max.	Min.	Max.	Min.	Max.	Min.
—	0.1181	+0.00008	-0.00008	+0.00016	-0.00008	+0.00024	-0.00016	+0.00016	0	+0.00024	0	+0.00039	0
0.1181	0.2362	+0.00012	-0.00008	+0.00024	-0.00008	+0.00031	-0.00016	+0.00024	+0.00004	+0.00035	+0.00004	+0.00051	+0.00004
0.2362	0.3937	+0.00016	-0.00008	+0.00028	-0.00008	+0.00039	-0.00020	+0.00028	+0.00004	+0.00039	+0.00004	+0.00063	+0.00004
0.3937	0.7087	+0.00020	-0.00012	+0.00031	-0.00012	+0.00047	-0.00024	+0.00035	+0.00004	+0.00047	+0.00004	+0.00075	+0.00004
0.7087	1.1811	+0.00020	-0.00016	+0.00035	-0.00016	+0.00051	-0.00031	+0.00043	+0.00008	+0.00059	+0.00008	+0.00091	+0.00008
1.1811	1.9685	+0.00024	-0.00020	+0.00043	-0.00020	+0.00059	-0.00039	+0.00051	+0.00008	+0.00071	+0.00008	+0.00106	+0.00008
1.9685	3.1496	+0.00024	-0.00028	+0.00047	-0.00028	+0.00071	-0.00047	+0.00059	+0.00008	+0.00083	+0.00008	+0.00126	+0.00008
3.1496	4.7244	+0.00024	-0.00035	+0.00051	-0.00035	+0.00079	-0.00059	+0.00071	+0.00012	+0.00098	+0.00012	+0.00150	+0.00012
4.7244	7.0866	+0.00028	-0.00043	+0.00055	-0.00043	+0.00087	-0.00071	+0.00083	+0.00012	+0.00110	+0.00012	+0.00169	+0.00012
7.0866	9.8425	+0.00028	-0.00051	+0.00063	-0.00051	+0.00098	-0.00083	+0.00094	+0.00016	+0.00130	+0.00016	+0.00197	+0.00016
9.8425	12.4016	+0.00028	-0.00063	+0.00063	-0.00063	+0.00102	-0.00102	+0.00106	+0.00016	+0.00142	+0.00016	+0.00220	+0.00016
12.4016	15.7480	+0.00028	-0.00071	+0.00071	-0.00071	+0.00114	-0.00110	+0.00114	+0.00016	+0.00157	+0.00016	+0.00240	+0.00016

Diameter in		Deviations in						Deviations in					
>	≤	m5		m6		m7		n5		n6		n7	
		Max.	Min.	Max.	Min.	Max.	Min.	Max.	Min.	Max.	Min.	Max.	Min.
—	0.1181	+0.00024	+0.00008	+0.00031	+0.00008	+0.00047	+0.00008	+0.0003	+0.0002	+0.0004	+0.0002	+0.0006	+0.0002
0.1181	0.2362	+0.00035	+0.00016	+0.00047	+0.00016	+0.00063	+0.00016	+0.0005	+0.0003	+0.0006	+0.0003	+0.0008	+0.0003
0.2362	0.3937	+0.00047	+0.00024	+0.00059	+0.00024	+0.00083	+0.00024	+0.0006	+0.0004	+0.0007	+0.0004	+0.0010	+0.0004
0.3937	0.7087	+0.00059	+0.00028	+0.00071	+0.00028	+0.00098	+0.00028	+0.0008	+0.0005	+0.0009	+0.0005	+0.0012	+0.0005
0.7087	1.1811	+0.00067	+0.00031	+0.00083	+0.00031	+0.00114	+0.00031	+0.0009	+0.0006	+0.0011	+0.0006	+0.0014	+0.0006
1.1811	1.9685	+0.00079	+0.00035	+0.00098	+0.00035	+0.00134	+0.00035	+0.0011	+0.0007	+0.0013	+0.0007	+0.0017	+0.0007
1.9685	3.1496	+0.00094	+0.00043	+0.00118	+0.00043	+0.00161	+0.00043	+0.0013	+0.0008	+0.0015	+0.0008	+0.0020	+0.0008
3.1496	4.7244	+0.00110	+0.00051	+0.00138	+0.00051	+0.00189	+0.00051	+0.0015	+0.0009	+0.0018	+0.0009	+0.0023	+0.0009
4.7244	7.0866	+0.00130	+0.00059	+0.00157	+0.00059	+0.00217	+0.00059	+0.0018	+0.0011	+0.0020	+0.0011	+0.0026	+0.0011
7.0866	9.8425	+0.00146	+0.00067	+0.00181	+0.00067	+0.00248	+0.00067	+0.0020	+0.0012	+0.0024	+0.0012	+0.0030	+0.0012
9.8425	12.4016	+0.00169	+0.00079	+0.00205	+0.00079	+0.00283	+0.00079	+0.0022	+0.0013	+0.0026	+0.0013	+0.0034	+0.0013
12.4016	15.7480	+0.00181	+0.00083	+0.00224	+0.00083	+0.00307	+0.00083	+0.0024	+0.0015	+0.0029	+0.0015	+0.0037	+0.0015

Diameter in		Deviations in					
>	≤	p6		r6		r7	
		Max.	Min.	Max.	Min.	Max.	Min.
3.1496	3.9370	+0.0023	+0.0015	-	-	-	-
3.9370	4.7244	+0.0023	+0.0015	-	-	-	-
4.7244	5.5118	+0.0027	+0.0017	+0.0035	+0.0026	-	-
5.5118	6.2992	+0.0027	+0.0017	+0.0035	+0.0026	-	-
6.2992	7.0866	+0.0027	+0.0017	+0.0035	+0.0026	-	-
7.0866	7.8740	+0.0031	+0.0020	+0.0042	+0.0030	-	-
7.8740	8.8583	+0.0031	+0.0020	+0.0043	+0.0031	+0.0050	+0.0031
8.8583	9.8425	+0.0031	+0.0020	+0.0044	+0.0033	+0.0051	+0.0033
9.8425	11.0236	+0.0035	+0.0022	+0.0050	+0.0037	+0.0057	+0.0037
11.0236	12.4016	+0.0035	+0.0022	+0.0051	+0.0039	+0.0059	+0.0039
12.4016	13.9764	+0.0039	+0.0024	+0.0057	+0.0043	+0.0065	+0.0043
13.9764	15.7480	+0.0039	+0.0024	+0.0059	+0.0045	+0.0067	+0.0045
15.7480	17.7165	+0.0043	+0.0027	+0.0065	+0.0050	+0.0074	+0.0050
17.7165	19.6850	+0.0043	+0.0027	+0.0068	+0.0052	+0.0077	+0.0052

MOUNTING DESIGNS

METRIC SERIES NEEDLE ROLLER BEARINGS (EXCEPT DRAWN CUP BEARINGS)

Metric series needle roller bearings are available with Radial Internal Clearance (RIC) designations per either of the following tables: per "ISO/ABMA 'C' Clearance." Non-standard values also are available by special request. Standard radial internal clearance values are listed in the following tables based on bore size. The clearance required for a given application depends on the desired operating precision, rotational speed of the bearing and the fitting practice used. Most applications use a normal or C0 clearance. Typically, larger clearance reduces the operating zone of the bearing, increases the maximum roller load and reduces the bearing's expected life.

Table A-6. Metric series needle roller bearing radial internal clearance limits

Bore		C2		C0		C3		C4	
		RIC							
over	incl.	Max.	Min.	Max.	Min.	Max.	Min.	Max.	Min.
mm in	mm in	mm in	mm in	mm in	mm in	mm in	mm in	mm in	mm in
-	30.000	0.025	0.000	0.045	0.020	0.060	0.035	0.075	0.050
-	1.1811	0.0010	0.0000	0.0018	0.0008	0.0024	0.0014	0.0030	0.0020
30.000	40.000	0.030	0.005	0.050	0.025	0.070	0.045	0.085	0.060
1.1811	1.5748	0.0012	0.0002	0.0020	0.0010	0.0028	0.0018	0.0033	0.0024
40.000	50.000	0.035	0.005	0.060	0.030	0.080	0.050	0.100	0.070
1.5748	1.9685	0.0014	0.0002	0.0024	0.0012	0.0031	0.0020	0.0039	0.0028
50.000	65.000	0.040	0.010	0.070	0.040	0.090	0.060	0.110	0.080
1.9685	2.5591	0.0016	0.0004	0.0028	0.0016	0.0035	0.0024	0.0043	0.0031
65.000	80.000	0.045	0.010	0.075	0.040	0.100	0.065	0.125	0.090
2.5591	3.1496	0.0018	0.0004	0.0030	0.0016	0.0039	0.0026	0.0049	0.0035
80.000	100.000	0.050	0.015	0.085	0.050	0.110	0.075	0.140	0.105
3.1496	3.9370	0.0020	0.0006	0.0033	0.0020	0.0043	0.0030	0.0055	0.0041
100.000	120.000	0.055	0.015	0.090	0.050	0.125	0.085	0.165	0.125
3.9370	4.7244	0.0022	0.0006	0.0035	0.0020	0.0049	0.0033	0.0065	0.0049
120.000	140.000	0.060	0.015	0.105	0.060	0.145	0.100	0.190	0.145
4.7244	5.5118	0.0024	0.0006	0.0041	0.0024	0.0057	0.0039	0.0075	0.0057
140.000	160.000	0.070	0.020	0.120	0.070	0.165	0.115	0.215	0.165
5.5118	6.2992	0.0028	0.0008	0.0047	0.0028	0.0065	0.0045	0.0085	0.0065
160.000	180.000	0.075	0.025	0.125	0.075	0.170	0.120	0.220	0.170
6.2992	7.0866	0.0030	0.0010	0.0049	0.0030	0.0067	0.0047	0.0087	0.0067
180.000	200.000	0.090	0.035	0.145	0.090	0.195	0.140	0.250	0.195
7.0866	7.8740	0.0035	0.0014	0.0057	0.0035	0.0077	0.0055	0.0098	0.0077
200.000	225.000	0.105	0.045	0.165	0.105	0.220	0.160	0.280	0.220
7.8740	8.8583	0.0041	0.0018	0.0065	0.0041	0.0087	0.0063	0.0110	0.0087
225.000	250.000	0.110	0.045	0.175	0.110	0.235	0.170	0.300	0.235
8.8583	9.8425	0.0043	0.0018	0.0069	0.0043	0.0093	0.0067	0.0118	0.0093
250.000	280.000	0.125	0.055	0.195	0.125	0.260	0.190	0.330	0.260
9.8425	11.0236	0.0049	0.0022	0.0077	0.0049	0.0102	0.0075	0.0130	0.0102
280.000	315.000	0.130	0.055	0.205	0.130	0.275	0.200	0.350	0.275
11.0236	12.4016	0.0051	0.0022	0.0081	0.0051	0.0108	0.0079	0.0138	0.0108
315.000	355.000	0.145	0.065	0.225	0.145	0.305	0.225	0.385	0.305
12.4016	13.9764	0.0057	0.0026	0.0089	0.0057	0.0120	0.0089	0.0152	0.0120
355.000	400.000	0.190	0.100	0.280	0.190	0.370	0.280	0.460	0.370
13.9764	15.7480	0.0075	0.0039	0.0110	0.0075	0.0146	0.0110	0.0181	0.0146
400.000	450.000	0.210	0.110	0.310	0.210	0.410	0.310	0.510	0.410
15.7480	17.7165	0.0083	0.0043	0.0122	0.0083	0.0161	0.0122	0.0201	0.0161
450.000	500.000	0.220	0.110	0.330	0.220	0.440	0.330	0.550	0.440
17.7165	19.6850	0.0087	0.0043	0.0130	0.0087	0.0173	0.0130	0.0217	0.0173

METRIC SERIES BEARING CHAMFER DIMENSIONS

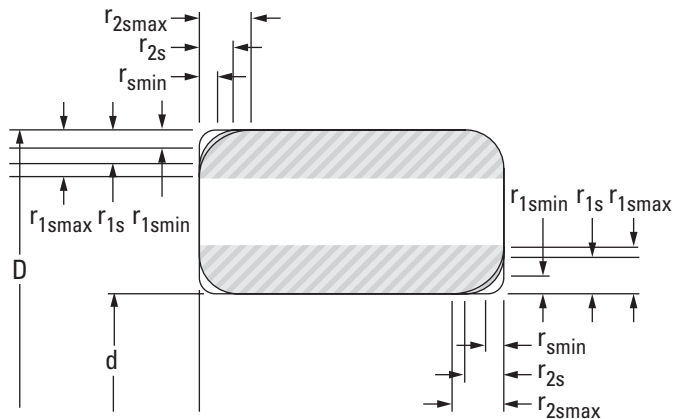

Radial Bearings

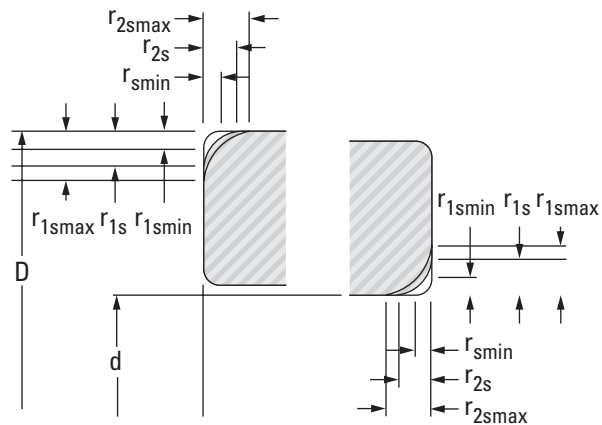

Thrust Bearings

Table A-7. Chamfer dimensions of radial bearings metric series

$r_{s \text{ min}}$	d		$r_{1s \text{ max}}$	$r_{2s \text{ max}}$
	Nominal bore dia.			
mm in	mm in	mm in	mm in	mm in
0.150 0.0059	all		0.300	0.600
	all		0.0118	0.0236
0.200 0.0079	all		0.500	0.800
	all		0.0197	0.0315
0.300 0.0118	≤ 40.000		0.600	1.000
	> 40.000		0.800	1.000
	≤ 1.5748		0.0236	0.0394
	> 1.5748		0.0315	0.0394
0.600 0.0236	≤ 40.000		1.000	2.000
	> 40.000		1.300	2.000
	≤ 1.5748		0.0394	0.0787
	> 1.5748		0.0512	0.0787
1.000 0.0394	≤ 50.000		1.500	3.000
	> 50.000		1.900	3.000
	≤ 1.9685		0.0591	0.1181
	> 1.9685		0.0748	0.1181
1.100 0.0433	≤ 120.000		2.000	3.500
	> 120.000		2.500	4.000
	4.7244		0.0787	0.1378
	4.7244		0.0984	0.1575
1.500 0.0591	≤ 120.000		2.300	4.000
	> 120.000		3.000	5.000
	4.7244		0.09055	0.1575
	4.7244		0.1181	0.19685
2.000 0.0787	≤ 80.000		3.000	4.500
	$> 80.000 \leq 220.000$		3.500	5.000
	> 220.000		3.800	6.000
	≤ 3.1496		0.1181	0.1772
	$> 3.1496 \leq 8.6614$		0.1378	0.19685
2.100 0.0827	≤ 280.000		4.000	6.500
	> 280.000		4.500	7.000
	11.0236		0.1575	0.2559
	11.0236		0.1772	0.2756

Table A-8. Chamfer dimensions of thrust bearings metric series

$r_{s \text{ min}}$	$r_{1s \text{ max}}$	$r_{2s \text{ max}}$
mm in	mm in	mm in
0.300 0.0118	0.800 0.0315	0.800 0.0315
0.600 0.0236	1.500 0.0591	1.500 0.0591
1.000 0.0394	2.200 0.0866	2.200 0.0866
1.100 0.0433	2.700 0.1063	2.700 0.1063
1.500 0.0591	3.500 0.1378	3.500 0.1378
2.000 0.0787	4.000 0.1575	4.000 0.1575

ABMA / ISO Symbols

- d Bearing bore diameter, nominal and shaft-piloted washer bore diameter, nominal.
- D Bearing outside diameter, nominal and housing-piloted washer outside diameter, nominal.
- $r_{s \text{ min}}$ Smallest permissible single chamfer dimension (minimum limit).
- $r_{1s \text{ max}}$ Largest permissible single chamfer dimension in a radial direction.
- $r_{2s \text{ max}}$ Largest permissible single chamfer dimension in an axial direction.

SHAFT DESIGNS

BEARINGS WITHOUT INNER RINGS

When the shaft is used as the inner raceway for needle roller bearings it must have a hardness between 58 and 64 HRC and a wave-free finish in order to realize the full load-carrying capability of the bearing.

- 1. Metallurgy** – either case-hardening or through-hardening grades of good bearing-quality steel are satisfactory for raceways. Steels that are modified for free machining, such as those high in sulfur content and particularly those containing lead, are seldom satisfactory for raceways.

To realize full bearing capacity, the raceway area must be at least surface hard with a reasonable core strength. It is preferred that the case depth be not less than 0.38 mm (0.0150 in). The preferred surface hardness is equivalent to 58 HRC. If the raceway is of lesser hardness, see the modification factors shown in Tables A-3 and A-4 on page A-7.

The minimum effective case depth of hardened and ground raceways, for use with all types of needle roller bearings, depends on the applied load, the diameter of the rolling elements and the core strength of the steel used. To calculate the approximate case depth the following formula may be used:

$$\text{Min case depth} = (0.07 \text{ to } 0.12) \times D_w$$

D_w is the diameter of the rolling element.

The high value should apply to a low core-strength material and/or heavy loads.

The effective case is defined as the distance from the surface, after final grind, to the 50 HRC hardness level.

- 2. Strength** – the shaft must be of sufficient strength to keep the operating deflections within the limits outlined.
- 3. Tolerance** – the suggested shaft diameter tolerances for each type of needle roller bearing are indicated in the appropriate section of this catalog.
- 4. Variation of mean shaft diameter** – within the length of the bearing raceway should not exceed 0.008 mm (0.0003 in), or one-half the diameter tolerance (whichever is smaller).
- 5. Deviation from circular form** – the radial deviation from true circular form of the raceway should not exceed 0.0025 mm (0.0001 in) for diameters up to and including 25.000 mm (1.0000 in). For raceways greater than 25.000 mm (1.0000 in), the allowable radial deviation should not exceed 0.0025 mm (0.0001 in) multiplied by a factor of the raceway diameter divided by 25.000 for mm (1.0000 for in).
- 6. High frequency lobing** – the lobing which occurs 10 or more times around the circumference of a shaft and exceeds 0.0004 mm (0.000015 in) peak-to-valley is defined as chatter. Chatter usually causes undesirable noise and reduces fatigue life.

- 7. Surface finish** – In addition to a wave-free finish, the raceway surface roughness of $R_a \leq 0.2 \mu\text{m}$ (8.0 μin) must be maintained for the bearing to utilize its full load rating. The raceway area also must be free of nicks, burrs, scratches and dents. Oil holes are permissible in the raceway area, but care must be taken to blend the edges gently into the raceway, and if possible, the hole should be located in the unloaded zone of the raceway.

Care also must be taken to prevent grind reliefs, fillets, etc., from extending into the raceway area. If the rollers overhang a grind relief or step on the shaft, there will be high stress concentration with resultant early damage.

- 8. End chamfer** – for the most effective assembly of the shaft into a bearing, the end of the shaft should have a large chamfer or rounding. This should help in preventing damage to the roller complement, scratching of the raceway surface, and nicking of the shaft end.
- 9. Sealing surface** – in some instances, bearings have integral or immediately adjacent seals that operate on the surface ground for the bearing raceway. Here, particular attention should be paid to the pattern of the shaft finish. In no instance should there be a “lead,” or spiral effect, as often occurs with through-feed centerless grinding. Such a “lead” may pump lubricant past the seal.

BEARINGS WITH INNER RINGS

When it is undesirable or impractical to prepare the shaft to be used as a raceway, inner rings are available as listed in the tabular pages. If the shaft is not used directly as a raceway, the following design specifications must be met:

- 1. Strength** – the shaft must be of sufficient strength to keep the operating deflections within the limits outlined.
- 2. Tolerance** – the suggested shaft diameter tolerances for each type of needle roller bearing are indicated in the appropriate section of the catalog.
- 3. Variation of mean shaft raceway diameter and deviation from circular form of the raceway** – should not exceed one-half the shaft diameter tolerance.
- 4. Surface finish** – the surface finish should not exceed R_a 1.6 μm (63 μin).
- 5. Locating shoulders or steps** – locating shoulders or steps in the shaft must be held to close concentricity with the bearing seat to prevent imbalance and resultant vibrations.

HOUSING DESIGNS

BEARINGS WITH OUTER RINGS

For bearings with outer rings, the function of the housing is to locate and support the outer ring. The following specifications must be met:

- 1. Strength** – housings should be designed so that the radial loads placed on the bearings will cause a minimum of deflection or distortion of the housing.
- 2. Variation of mean housing diameter** – within the length of the outer ring should not exceed 0.013 mm (0.0005 in).
- 3. Deviation from circular form** – the housing bore should be round within one-half the housing bore tolerance.
- 4. Parallelism** – when possible, line bore housings that are common to one shaft to obtain parallelism of the housing bores and the shaft axis.
- 5. Surface finish** – The surface finish should not exceed R_a 1.6 μm (63 μin).
- 6. End chamfer** – to permit easy introduction of the bearing into the housing, the end of the housing should have a generous chamfer.

Only heavy-duty needle roller bearings can be installed into housings with a transition fit or a clearance fit. The outer ring should be a transition fit in the housing when it rotates relative to the load. The outer ring may be a clearance fit in the housing when it is stationary relative to the load. In either case, locate the bearings by shoulders, or other locating devices, to prevent axial movement.

Since only the heavy-duty needle roller bearing does not require an interference fit in the housing to round and size it properly, a split housing may be used if desired. Dowels should be used to maintain proper register of the housing sections.

Drawn cup bearings have a thin case-hardened outer ring that is out-of-round from the hardening operation. For proper mounting it must **always** be pressed into the housing. Split housings will not round and size a drawn cup bearing. When split housings must be used, the bearing should first be mounted in a cylindrical sleeve.

The housing should be of sufficient tensile strength and section to round and size the bearing. It must be designed for minimum distortion under load. Steel or cast iron housings are preferred. Housing bores in low tensile strength materials such as aluminum, magnesium, phenolics, etc., should be reduced to provide more interference fit. Thin section cast iron and steel housings may also require reduced bores. Consult your representative for suggestions when working with these lower strength housings.

The housing should be through-bored if possible. When shouldered housing bores are unavoidable, the bearing should be located far enough from the shoulder to avoid the danger of crushing the end of the drawn cup during installation.

When the drawn cup bearing is mounted close to the housing face, care should be taken to mount the bearing at least 0.250 mm (0.0100 in) within the housing face to protect the bearing lip.

BEARINGS WITHOUT OUTER RINGS

In many cases, such as with gear bores, it is desirable to have the housing bore serve as the outer raceway for radial needle roller and cage assemblies or loose needle roller complements. In those instances, as for shafts used as a raceway, the housing bore must have a hardness between 58 and 64 HRC and a roughness $R_a \leq 0.2 \mu\text{m}$ (8.0 μin), so that the full load-carrying capacity of the bearing is realized.

- 1. Strength** – the housing must be of sufficient cross section to maintain proper roundness and running clearance under maximum load.
- 2. Metallurgical** – material selection, hardness and case depth should be consistent with the requirements for inner raceways given in the shaft design.
- 3. Variation of mean housing raceway diameter and deviation from circular form of the raceway** – the raceway out-of-roundness and taper should not exceed 0.008 mm (0.0003 in) or one-half the bore tolerance, whichever is smaller. In addition, the bore diameter must never be smaller at both ends than in the center [sway-back].
- 4. Surface finish** – In addition to a wave-free finish, the raceway surface roughness of $R_a \leq 0.2 \mu\text{m}$ (8.0 μin) must be maintained for the bearing to utilize its full load rating. The raceway area also must be free of nicks, burrs, scratches and dents.
- 5. Grind reliefs** – care must be exercised to ensure that grind reliefs, fillets, etc., do not extend to the raceway. Oil holes in the raceway area are permissible, but the edges must be blended smoothly with the raceway and, if possible, the hole should be located in the unloaded zone of the raceway.

LUBRICATION AND SEALS

To help maintain a rolling bearing's anti-friction characteristics, lubrication is needed to:

- Minimize rolling resistance due to deformation of the rolling elements and raceway under load by separating the mating surfaces.
- Minimize sliding friction occurring between rolling elements, raceways and cage.
- Transfer heat (with oil lubrication).
- Protect from corrosion and, with grease lubrication, from contaminant ingress.

Modern lubricants do this very effectively. Although in many applications, the means by which they accomplish this are extremely complex and not completely understood. Because the principles involved with lubricating rolling element bearings are complex; and do not have to be known to employ lubricants successfully, this discussion will stress the practical rather than the theoretical aspects of lubrication.

LUBRICATION SELECTION

The wide range of bearing types and operating conditions precludes any simple, all-inclusive statement or guideline allowing the selection of the proper lubricant. At the design level, the first consideration is whether oil or grease is best for the particular operation. The advantages of oil and grease are outlined in the table below. When heat must be carried away from the bearing, oil must be used. It is nearly always preferred for very high-speed applications. For limiting speeds of grease and oil-lubricated bearings, refer to the section entitled Torque.

Table A-9. Advantages of oil and grease

Oil	Grease
Carries heat away from the bearings	Simplifies seal design and acts as a sealant
Carries away moisture and particulate matter	Permits prelubrication of sealed or shielded bearings
Easily controlled lubrication	Generally requires less frequent lubrication

LUBRICANT ADDITIVES

Additives are materials, usually chemicals, that improve specific properties when added to lubricants. Additives, when properly formulated into a lubricant, can increase lubricant life, provide greater resistance to corrosion, increase load-carrying capacity and enhance other properties. Additives are very complex and should not be added indiscriminately to lubricants as a cure-all for all lubrication problems.

The more common lubricant additives include:

- Oxidation inhibitors for increasing lubricant service life.
- Rust or corrosion inhibitors to protect surfaces.
- Demulsifiers to promote oil and water separation.
- Viscosity-index improvers to decrease viscosity sensitivity to temperature change.
- Pour-point depressants to lower the pouring point at low temperatures.
- Lubricity agents to modify friction.
- Anti-wear agents to retard wear.
- Extreme pressure (EP) additives to prevent scoring under boundary-lubrication conditions.
- Detergents and dispersants to maintain cleanliness.
- Anti-foam agents to reduce foam.
- Tackiness agents to improve adhesive properties.

Inorganic additives such as molybdenum disulphide, graphite and zinc oxide are sometimes included in lubricants. In most roller bearing applications, inorganic additives are of no significant benefit. Conversely, as long as the concentration is low and the particle size small, they are not harmful.

Recently, the effects of lubricant chemistry on bearing life (as opposed to the purely physical characteristics) have received much emphasis. Rust, oxidation, extreme pressure and anti-wear additive packages are widely used in engine and gear oils. Fatigue testing has shown these additives may – depending on their chemical formulation, concentration and operating temperature – have a positive or negative impact on bearing life.

GUIDANCE FOR OIL/GREASE SELECTION

Oil Lubrication

Oils used for bearing lubrication should be high-quality, non-oxidizing mineral oils or synthetic oils with similar properties. Selection of the proper type of oils depends on bearing speed, load, operating temperature and method of lubrication. Some features and advantages of oil lubrication, in addition to the above, are as follows:

- Oil is a better lubricant for high speeds or high temperatures. It can be cooled to help reduce bearing temperature.
- With oil, it is easier to handle and control the amount of lubricant reaching the bearing. It is harder to retain in the bearing. Lubricant losses may be higher than with grease.
- As a liquid, oil can be introduced to the bearing in many ways, such as drip-feed, wick-feed, pressurized circulating systems, oil bath or air-oil mist. Each is suited for certain types of applications.
- Oil is easier to keep clean for recirculating systems.

Oil may be introduced to the bearing housing in many ways. The most common systems are:

- Oil bath. The housing is designed to provide a sump through which the rolling elements of the bearing will pass. Generally, the oil level should be no higher than the center point of the lowest rolling element. If speed is high, lower oil levels should be used to reduce churning. Gages or controlled elevation drains are used to achieve and maintain the proper oil level.
- Circulating system. This system has the advantages of:
 - An adequate supply of oil for both cooling and lubrication.
 - Metered control of the quantity of oil delivered to each bearing.
 - Removal of contaminants and moisture from the bearing by flushing action.
 - Suitability for multiple bearing installations.
 - Large reservoir, which reduces deterioration. Increased lubricant life provides economical efficiency.
 - Incorporation of oil-filtering devices.
 - Positive control to deliver the lubricant where needed.

A typical circulating oil system consists of an oil reservoir, pump, piping and filter. A cooler may be required.

- Oil-mist lubrication. Oil-mist lubrication systems are used in high-speed, continuous operation applications. This system permits close control of the amount of lubricant reaching the bearings. The oil may be metered, atomized by compressed air and mixed with air, or it may be picked up from a reservoir using a venturi effect. In either case, the air is filtered and supplied under sufficient pressure to assure adequate lubrication of the bearings. Control of this type of lubrication system is accomplished by monitoring the operating temperatures of the bearings being lubricated. The continuous passage of the pressurized air and oil, through the labyrinth seals used in the system, prevents the entrance of contaminants from the atmosphere to the system. The successful operation of this type of system is based upon the following factors: proper location of the lubricant entry ports in relation to the bearings being lubricated, avoidance of excessive pressure drops across void spaces within the system, proper air pressure and oil quantity ratio to suit the particular application, and adequate exhaust of the air-oil mist after lubrication has been accomplished. To ensure “wetting” of the bearings, and to prevent possible damage to the rolling elements and races, it is imperative that the oil-mist system be turned on for several minutes before the equipment is started. The importance of “wetting” the bearing before starting cannot be overstated, and it also has particular significance for equipment that has been idled for extended periods of time.

OIL LUBRICATION GUIDELINES

Oil Lubrication

Lubricating oils are commercially available in many forms for automotive, industrial, aircraft and other uses. Oils are classified as either petroleum types (refined from crude oil) or synthetic types (produced by chemical synthesis).

Petroleum Oils

Petroleum oils are used for nearly all oil-lubricated applications of bearings. These oils have physical and chemical properties that can help in the selection of the correct oil for any bearing application.

Synthetic Oils

Synthetic oils cover a broad range of categories and include polyalphaolefins, silicones, polyglycols and various esters. In general, synthetic oils are less prone to oxidation and can operate at extreme hot or cold temperatures. Physical properties, such as pressure-viscosity coefficients, tend to vary between oil types and caution should be used when making oil selections.

The polyalphaolefins (PAO) have a hydrocarbon chemistry, which parallel petroleum oil both in their chemical structures and pressure-viscosity coefficients. Therefore, PAO oil is mostly used in the oil-lubricated applications of bearings when severe temperature environments (hot and cold) are encountered or when extended lubricant life is required. The silicone, ester and polyglycol oils have an oxygen-based chemistry that is structurally quite different from petroleum oils and PAO oils. This difference has a profound effect on its physical properties where pressure- viscosity coefficients can be lower compared to mineral and PAO oils. This means that these types of synthetic oils may actually generate a smaller EHD film thickness than a mineral or PAO oil of equal viscosity at operating temperature. Reductions in bearing fatigue life and increases in bearing wear could result from this reduction of lubricant film thickness.

Table A-10. Approximate temperature limits for oils

Oil type	° C	° F
Petroleum	149°	300°
Super refined petroleum	177°	350°
Synthetic hydrocarbon	204°	400°
Synthetic esters	204°	400°
Silicones	260°	500°
Polyphenylether	288°	550°
Perfluorinated	316°	600°

CLASSIFICATION

There are several classifications of oils based on viscosity grades. The most familiar are the Society of Automotive Engineers (SAE) classifications for automotive engine and gear oils. The American Society for Testing and Materials (ASTM) and the International Organization for Standardization (ISO) have adopted standard viscosity grades for industrial fluids. Fig. A-10 shows the viscosity comparisons of ISO/ASTM with SAE classification systems at 40° C (104° F).

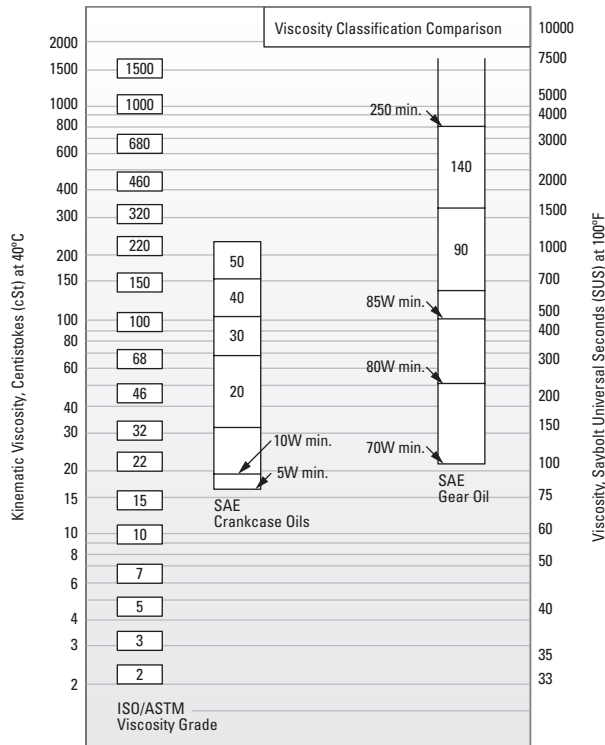

Fig. A-10. Viscosity classification comparison between ISO/ASTM grades (ISO 3448/ASTM D2442) and SAE grades (SAE J 300-80 for crankcase oils, SAE J 306-81 for axle and manual transmission oils)

The figure below can be used to predict the oil's kinematic viscosity versus temperature (use base oil for grease).

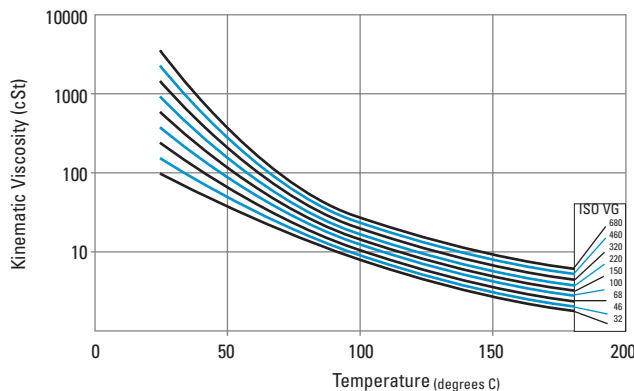

Fig. A-11. Temperature vs. kinematic viscosity

TYPICAL OIL LUBRICATION GUIDELINES

In this section, the properties and characteristics of lubricants for typical needle roller bearing applications are listed. These general characteristics have resulted from long, successful performance in these applications.

General Purpose Rust and Oxidation Lubricating Oil

General purpose rust and oxidation (R&O) inhibited oils are the most common type of industrial lubricant.

Table A-11. Suggested general purpose R&O lubricating oil properties

Properties	
Base stock:	Solvent refined, high viscosity-index petroleum oil
Additives:	Corrosion and oxidation inhibitors
Viscosity index:	80 min.
Pour point:	-10° C max. (14° F)
Viscosity grades:	ISO/ ASTM 32 through 220

Some low-speed and/or high-ambient temperature applications require the higher viscosity grades. And high-speed and/or low-temperature applications require the lower viscosity grades.

Industrial Extreme Pressure (EP) Gear Oil

Extreme pressure gear oils are used to lubricate bearings in all types of heavily loaded industrial equipment. They should be capable of withstanding heavy loads including abnormal shock loads common in heavy-duty equipment.

Table A-12. Suggested industrial EP gear oil properties

Properties	
Base stock:	Solvent refined, high viscosity-index petroleum oil
Additives:	Corrosion and oxidation inhibitors Extreme pressure (EP) additive ⁽¹⁾ - 15.8 kg (35 lb) min.
Viscosity index:	80 min.
Pour point:	-10° C max. (14° F)
Viscosity grades:	ISO/ ASTM 100, 150, 220, 320, 460

⁽¹⁾ ASTM D 2782

Industrial EP gear oils should be composed of a highly refined petroleum oil-based stock plus appropriate inhibitors and additives. They should not contain materials that are corrosive or abrasive to bearings. The inhibitors should provide long-term protection from oxidation and protect the bearing from corrosion in the presence of moisture. The oils should resist foaming in service and have good water separation properties. An EP additive protects against scoring under boundary-lubrication conditions. The viscosity grades suggested represent a wide range. High-temperature and/or slow-speed applications generally require the higher viscosity grades. Low temperatures and/or high speeds require the use of lower viscosity grades.

LUBRICATING GREASES

Definition

According to the ASTM definition, lubricating grease is a “solid to semi-fluid product of the dispersion of a thickening agent in a liquid lubricant; other ingredients imparting special properties may be included.” If this definition were applied in the manner a chemist would use to illustrate a chemical reaction, the composition of a grease could be described by the formula below.

Table A-13. Composition of grease

Fluids	+Thickening agents	+Special ingredients	= Lubricating grease
Mineral oils Esters Organic esters Glycols Silicones	Soaps Lithium, sodium Barium, calcium Strontium Non-soap (inorganic) Microgel (clay) Carbon black Silica-gel Non-soap (organic) Urea compounds Terephthamate Organic dyes	Oxidation inhibitors Rust inhibitors VI improver Tackiness Perfumes Dyes Metal deactivator	

At this time, there is no known universal anti-friction bearing grease. Each individual grease has certain limiting properties and characteristics.

Synthetic lubricating fluids, such as esters, organic esters and silicones are used with conventional thickeners or chemical additives to provide greases capable of performing over an extremely wide range of temperatures, from as low as -73° C (-100° F) to a high of 288° C (550° F).

The successful use of lubricating grease in roller bearings depends on the physical and chemical properties of the lubricant pertaining to the bearing, its application, installation and general environmental factors. Because the choice of a lubricating grease for a particular bearing under certain service conditions is often difficult to make, your representative should be consulted for proper suggestions.

Grease Lubrication

The simplest lubrication system for any bearing application is grease. Conventionally, greases used in bearing applications are petroleum oils of some specific viscosity that are thickened to the desired consistency by some form of metallic soap. Greases are available in many soap types such as sodium, calcium, lithium, calcium-complex and aluminium-complex. Organic and inorganic type non-soap thickeners also are used in some products.

Soap Type

Calcium greases have good water resistance. Sodium greases generally have good stability and will operate at higher temperatures, but they absorb water and cannot be used where moisture is present. Lithium, calcium-complex and aluminium-complex greases generally combine the higher temperature properties and stability of sodium grease with the water resistance of calcium grease. These greases are often referred to as multi-purpose greases since they combine the two most important lubricant advantages into one product.

CHARACTERISTICS AND OPERATING ENVIRONMENTS

Listed below are the general characteristics of prominent rolling bearing greases.

Table A-14. General characteristics of prominent rolling bearing greases

Thickener	Typical Dropping PT		Usable ⁽¹⁾ Temperature		Typical Water Resistance
	° C	° F	° C	° F	
Sodium Soap	260+	500+	121	250	Poor
Lithium Soap	193	380	104	220	Good
Polyurea	238	460	149	300	Excellent
Lithium Complex Soap	260+	500+	163	325	Good

⁽¹⁾ Continuous operation with no relubrication. Depending upon the formulation the service limits may vary. The usable limit can be extended significantly with relubrication.

Polyurea as a thickener for lubricating fluids is one of the most significant lubrication developments in more than 30 years. Polyurea grease performance in a wide range of bearing applications is outstanding and in a relatively short time it has gained acceptance as a factory-packed lubricant for ball bearings.

Consistency

Greases may vary in consistency from semi-fluids, hardly thicker than a viscous oil, to solid grades almost as hard as a soft wood.

Consistency is measured by a penetrometer in which a standard weighted cone is dropped into the grease. The distance the cone penetrates (measured in tenths of a millimeter in a specific time) is the penetration number.

The National Lubricating Grease Institute (N.L.G.I.) classification of grease consistency is shown below:

Table A-15. NLGI Classifications

NLGI grease grades	Penetration number
0	355-385
1	310-340
2	265-295
3	220-250
4	175-205
5	130-160
6	85-115

Low Temperatures

Starting torque in a grease-lubricated bearing at low temperatures can be critical. Some greases may function adequately as long as the bearing is operating, but resistance to initial movement is such that the starting torque is excessive. In certain smaller machines starting is impossible when very cold. Under such operating circumstances, the greases containing low-temperature characteristic oils are generally required.

If the operating temperature range is wide, synthetic fluid greases offer definite advantages. Greases are available to provide very low starting and running torque at temperatures as low as -73°C (-100°F). In certain instances, these greases perform better in this respect than oil.

An important point concerning lubricating greases is that the starting torque is not necessarily a function of the consistency or the channel properties of the grease. It appears to be more a function of the individual properties of the particular grease and is difficult to measure. Experience alone will indicate whether one grease is superior to another.

High Temperatures

The high temperature limit for modern grease is generally a function of the thermal and oxidation stability of the fluid and the effectiveness of the oxidation inhibitors. The graph to the right was prepared using military-specification greases to illustrate the thermal limitations of mineral oil, ester, silicone, and fluorinated ether greases. The limits as shown, apply only to prelubricated bearings or to applications where relubrication is not possible. Where provisions have been made for relubrication, the temperature limits may be extended, provided the interval between cycles is reduced accordingly.

A rule of thumb, developed from years of testing grease-lubricated bearings, indicates that grease life is halved for every 10°C (18°F) increase in temperature. For example, if a particular grease is providing 2000 hours of life at 90°C (194°F), by raising the temperature to 100°C (212°F), reduction in life to approximately 1000 hours would result. On the other hand, 4000 hours could be expected by lowering the temperature to 80°C (176°F).

It becomes obvious that the reactions started by the normal reaction of lubricant with oxygen increases rapidly at higher temperatures. The lubricants undergo a series of chemical reactions that ultimately result in the development of viscous or hard residues that interfere with the operation of the bearing.

Thermal stability, oxidation resistance and temperature limitations must be considered when selecting greases for high-temperature applications. In non-relubricatable applications, highly refined mineral oils or chemically stable synthetic fluids are required as the oil component of greases for operation at temperatures above 121°C (250°F).

Table A-16. Approximate temperature limits for grease thickeners

Grease thickener	$^{\circ}\text{C}$	$^{\circ}\text{F}$
Soaps	121°	250°
Complexes	177°	350°
Polyureas	177°	350°
Non-soap	>260°	>500°

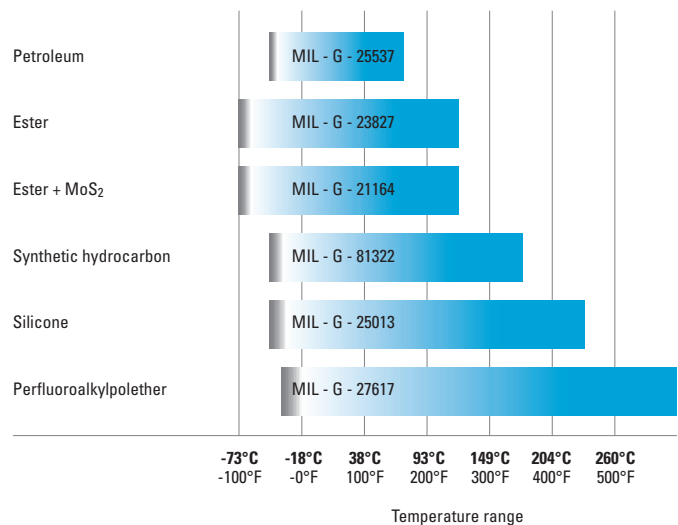

Fig. A-12. Lubrication grease temperature ranges

⚠ WARNING

Failure to observe the following warnings could create a risk of serious bodily harm.

Proper maintenance and handling practices are critical. Failure to follow installation instructions and to maintain proper lubrication can result in equipment failure.

Never spin a bearing with compressed air. The rolling elements may be forcefully expelled.

WARNING

Mixing grease types can cause the lubricant to become ineffective, which can result in equipment failure, creating a risk of serious bodily harm.

Table A-17. Grease compatibility chart

	Al Complex	Ba Complex	Ca Stearate	Ca 12 Hydroxy	Ca Complex	Ca Sulfonate	Clay Non-Soap	Li Stearate	Li 12 Hydroxy	Li Complex	Polyurea	Polyurea S S
Aluminum Complex	Best Choice	Incompatible	Incompatible	Compatible	Incompatible	Borderline	Incompatible	Incompatible	Incompatible	Compatible	Incompatible	Compatible
Barium Complex	Incompatible	Best Choice	Incompatible	Compatible	Incompatible	Compatible	Incompatible	Incompatible	Incompatible	Incompatible	Incompatible	Borderline
Calcium Stearate	Incompatible	Incompatible	Best Choice	Compatible	Incompatible	Compatible	Compatible	Compatible	Borderline	Compatible	Incompatible	Compatible
Calcium 12 Hydroxy	Compatible	Compatible	Compatible	Best Choice	Borderline	Borderline	Compatible	Compatible	Compatible	Compatible	Incompatible	Compatible
Calcium Complex	Incompatible	Incompatible	Incompatible	Borderline	Best Choice	Incompatible	Incompatible	Incompatible	Incompatible	Compatible	Compatible	Compatible
Calcium Sulfonate	Borderline	Compatible	Compatible	Borderline	Incompatible	Best Choice	Incompatible	Borderline	Borderline	Compatible	Incompatible	Compatible
Clay Non-Soap	Incompatible	Incompatible	Compatible	Compatible	Incompatible	Incompatible	Best Choice	Incompatible	Incompatible	Incompatible	Incompatible	Borderline
Lithium Stearate	Incompatible	Incompatible	Compatible	Compatible	Incompatible	Borderline	Incompatible	Best Choice	Compatible	Compatible	Incompatible	Compatible
Lithium 12 Hydroxy	Incompatible	Incompatible	Borderline	Compatible	Incompatible	Borderline	Incompatible	Compatible	Best Choice	Compatible	Incompatible	Compatible
Lithium Complex	Compatible	Incompatible	Compatible	Compatible	Compatible	Incompatible	Incompatible	Compatible	Compatible	Best Choice	Incompatible	Compatible
Polyurea Conventional	Incompatible	Incompatible	Incompatible	Incompatible	Compatible	Incompatible	Incompatible	Incompatible	Incompatible	Incompatible	Best Choice	Compatible
Polyurea Shear Stable	Compatible	Borderline	Compatible	Compatible	Compatible	Compatible	Borderline	Compatible	Compatible	Compatible	Compatible	Best Choice

WET CONDITIONS

Water and moisture can be particularly conducive to bearing damage. Lubricating greases may provide a measure of protection from this contamination. Certain greases, the calcium, lithium and non-soap type, for example, are highly water-resistant. However, these greases exhibit poor rust-preventative characteristics unless properly inhibited.

Sodium-soap greases emulsify with small amounts of moisture that may be present and prevent the moisture from coming in contact with the bearing surfaces. In certain applications, this characteristic may be advantageous; however, emulsions are generally considered undesirable.

Many bearing applications require lubricants with special properties or lubricants formulated specifically for certain environments, such as:

- Friction oxidation (fretting corrosion).
- Chemical and solvent resistance.
- Food handling.
- Quiet running.
- Space and/or vacuum.
- Electrical conductivity.

For assistance with these or other areas requiring special lubricants, consult your representative.

CONTAMINATION

Abrasive Particles

When needle roller bearings operate in a clean environment, the primary cause of damage is the eventual fatigue of the surfaces where rolling contact occurs. However, when particle contamination enters the bearing system, it is likely to cause damage such as bruising, which can shorten bearing life.

When dirt from the environment or metallic wear debris from some component in the application is allowed to contaminate the lubricant, wear can become the predominant cause of bearing damage. If, due to particle contamination of the lubricant, bearing wear becomes significant, changes will occur to critical bearing dimensions that could adversely affect machine operation.

Bearings operating in a contaminated lubricant exhibit a higher initial rate of wear than those running in an uncontaminated lubricant. With no further contaminant ingress, this wear rate quickly diminishes. The contamination particles are reduced in size as they pass through the bearing contact area during normal operation.

Water

Either dissolved or suspended water in lubricating oils can exert a detrimental influence on bearing fatigue life. Water can cause bearing etching that also can reduce bearing fatigue life. The exact mechanism by which water lowers fatigue life is not fully understood. It has been suggested that water enters micro-cracks in the bearing races that are caused by repeated stress cycles. This leads to corrosion and hydrogen embrittlement in the micro-cracks, reducing the time required for these cracks to propagate to an unacceptable-sized spall.

Water-base fluids such as water, glycol and invert emulsions also have shown a reduction in bearing fatigue life. Although water from these sources is not the same as contamination, the results support the previous discussion concerning water-contaminated lubricants.

GREASES - APPLICATIONS AND LUBRICATING METHODS

Grease lubrication is generally applicable to the following conditions, and features low-to-moderate speed applications within operating temperature limits of the grease:

- Easily confined in the housing. This is important in the food, textile and chemical industries.
- Bearing enclosure and seal design simplified.
- Improves the efficiency of external mechanical seals to give better protection to the bearing.
- Successfully used for integrally-sealed, prelubricated ball bearings.

Advantages of Prelubricated Bearings

Prelubricated shielded and sealed bearings are extensively used with much success in applications where:

- Grease might be injurious to other parts of the mechanism.
- Cost and space limitations preclude the use of a grease filled housing.
- Housings cannot be kept free of dirt and grit, water or other contaminants.
- Relubrication is impossible or would be a hazard to satisfactory use.

Prelubricated bearings are pre-packed with greases that have chemical and mechanical stability, and have demonstrated long-life characteristics in rotating bearings. Greases are filtered several times to remove all harmful material, and accurately metered so that each bearing receives the proper amount of grease.

LIMITING SPEEDS

In addition to the bearing load ratings, the tabular pages also list the limiting speed values which are the maximum speeds at which the bearings may operate. These speeds have been calculated for unsealed and sealed bearings of conventional design, tolerances and internal clearances, properly mounted with low applied loads using normal splash, drip feed or other methods of lubrication which will provide adequate cooling of the bearings. A bearing may operate at a speed higher than the listed limiting speed with the use of a clean, good quality oil and after prior consultation with Torrington's Engineering Department. With high speeds and high acceleration rates, the ratio of P/C should not fall below 0.02 to prevent skidding of the rolling elements.

Also the bearing should not be subjected to uneven stress distribution due to the effects of misalignment between the bearing housings, deformation of the shaft or housing.

Speeds Inadequate for Elastohydrodynamic Lubricating Film

International Standard **ISO 281** which covers calculation of dynamic load ratings and rating life states that at exceptionally low rotational speeds (i.e. the product of speed and pitch diameter (D_{pw}) in mm is less than 10000) the generated lubricant film is unlikely to be adequate to separate the rolling element/raceway contacts. At such operating conditions it may be inappropriate to calculate the bearing life although practical improvement in life, may be achieved with the use of lubricants of higher kinematic viscosity or containing EP additives.

NEEDLE ROLLER BEARINGS

Empirical torque equations for radial and thrust needle roller bearings were developed:

$$M = d_m (4.5 \times 10^{-7} v^{0.3} n^{0.6} + 0.12 F_r^{0.4})$$

v = Lubricant kinematic viscosity cSt

n = Rotational speed, min^{-1}

F_r = Radial load

d_m = Mean diameter

Testing also showed that full complement radial needle roller bearings operate at 1.5 to 2 times the torque determined for caged radial needle roller bearings. Similarly, the running torque of thrust needle roller bearings is given:

$$M = 4.5 \times 10^{-7} v^{0.3} n^{0.6} d_m + 0.016 F_a l$$

F_a = Axial load

l = Roller length

In both equations, the mean diameter d_m is the average of the bore and O.D. of the bearings, while the length (l) in the thrust bearing torque equation can be approximated using the bearing's radial section (e.g., $l = 1/2 [E_a - E_b]$).

E_a is raceway contact dimensions, outer.

E_b is raceway contact dimensions, inner.

The viscosity is in units of centistokes. A typical conversion factor for mineral oil is $1 \text{cSt} = 0.875 \text{cP}$.

Both of the aforementioned equations were determined for circulating oil lubrication systems. For grease lubrication, the viscosity of the base oil should be used to estimate the running torque.

NEEDLE ROLLER BEARINGS

B

B

B NEEDLE ROLLER BEARINGS

<i>Radial Needle Roller and Cage Assemblies</i>	B-3
<i>Drawn Cup Needle Roller Bearings</i>	B-41
<i>Drawn Cup Roller Clutches</i>	B-123
<i>Heavy-Duty Needle Roller Bearings</i>	B-143
<i>Track Rollers</i>	B-205
<i>Thrust Bearings, Assemblies, Washers</i>	B-267
<i>Combined Needle Roller Bearings</i>	B-327
<i>Needle Rollers, Accessories</i>	B-347

NEEDLE ROLLER BEARINGS

B

RADIAL NEEDLE ROLLER AND CAGE ASSEMBLIES

Overview: Needle roller and cage assemblies feature a complement of needles held in place by a cage with no inner or outer ring. The minimal cross section provides maximum load-carrying capability within the smallest envelope.

- **Sizes:** 3 mm – 165 mm (0.1181 in – 6.4961 in) bore.
- **Markets:** Automotive and truck transmissions, agricultural and construction equipment, two-cycle engines, pumps and compressors.
- **Features and Benefits:**
 - Unitized design simplifies handling and installation while allowing for increased lube flow.
 - Split and segmented designs allow mounting at difficult positions on crankshafts and gear shafts.
 - Controlled contour rollers optimize contact stress distribution.
 - Special manufacturing processes help increase roller fatigue resistance and minimize axial drift effects in critical applications.
 - Optimized cage piloting geometry minimizes pressure velocity effects.
 - Steel or polymer cages are available to suit your application requirements.
 - Coatings are available to help avoid corrosion and improve wear resistance.





Radial Needle Roller and Cage Assemblies – Metric Nominal Dimensions

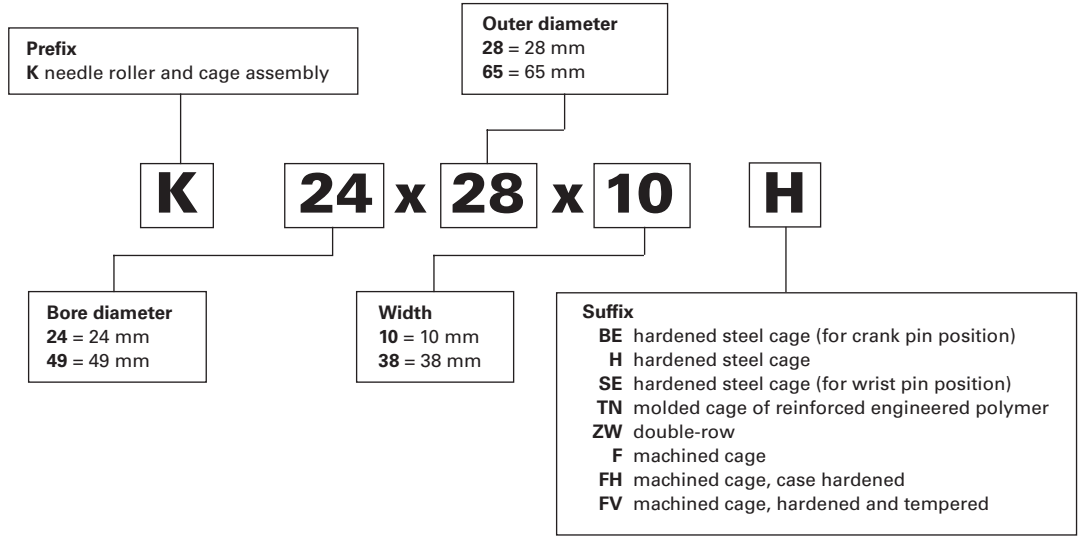

Radial Needle Roller and Cage Assemblies – Inch Nominal Dimensions

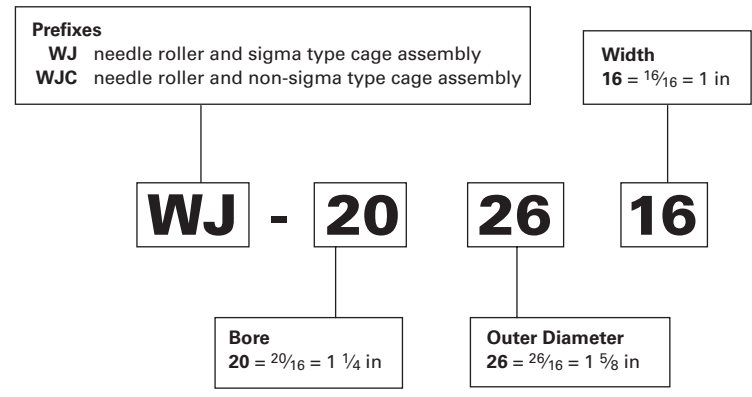

Radial Needle Roller and Cage Assemblies

Page

Introduction B-6

Single-Row, Double-Row Assemblies – Metric Series B-8

Radial Needle Roller and Cage Assemblies
for Connecting Rod Applications – Metric Series B-26

Assemblies for Crank Pin End Applications – Metric Series . . . B-31

Assemblies for Wrist Pin End Applications – Metric Series . . . B-33

Radial Needle Roller and Cage Assemblies – Inch Series . . . B-35

Single-Row Assemblies – Inch Series B-37



RADIAL NEEDLE ROLLER AND CAGE ASSEMBLIES

METRIC SERIES

Metric series radial needle roller and cage assemblies are available in a variety of sizes and designs. This catalog includes the most popular, standardized designs.

REFERENCE STANDARDS ARE:

- **ISO 3030** – needle roller bearings – radial needle roller and cage assemblies – boundary dimensions and tolerances.
- **DIN 5405 Part 1** – rolling bearings – needle roller bearings – radial needle roller and cage assemblies.
- **ANSI/ABMA 18.1** – needle roller bearings – radial, metric design.

Before selecting specific metric series radial needle roller and cage assemblies, the engineering section should be reviewed.

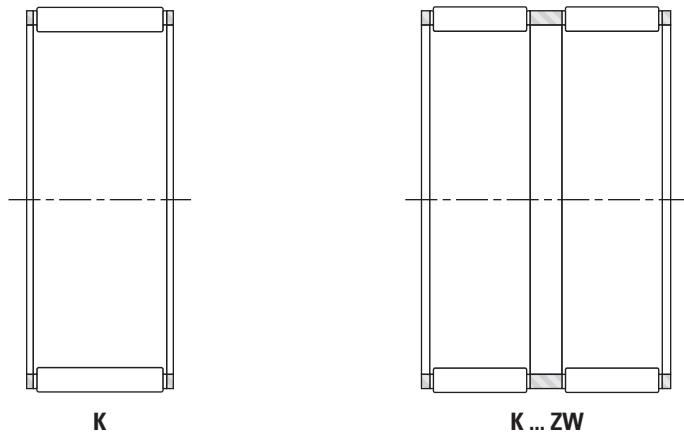

Fig. B-1. Types of Metric Series Radial Needle Roller and Cage Assemblies

Suffixes

TN	molded cage of reinforced engineered polymer
ZW	double-row
H	hardened steel cage
F	machined cage
FH	machined cage, case hardened
FV	machined cage, hardened and tempered

CONSTRUCTION

Radial needle roller and cage assemblies have a steel cage that provides both inward and outward retention for the needle rollers. The designs provide maximum cage strength consistent with the inherent high load-ratings of needle roller bearings. Accurate guidance of the needle rollers by the cage bars allows for operation at high speeds. Needle roller and cage assemblies have either one or two rows of needle rollers.

Also listed are metric series needle roller and cage assemblies using molded, one-piece glass-reinforced engineered polymer cages (suffix TN). These operate well at temperatures up to

120° C (250° F) over extended periods. However, care should be exercised when these assemblies are lubricated with oils containing additives as service life may be reduced if the operating temperature exceeds 100° C (212° F). At such high temperatures oil can deteriorate with time and it is suggested that oil change intervals are observed.

Needle rollers with relieved ends used in these assemblies are made of high-carbon chrome steel, through-hardened, ground and lapped to close tolerances for diameter and roundness. See the engineering section for further discussion of relieved end rollers.

DIMENSIONAL ACCURACY

NEEDLE ROLLER GROUPS (GAGES)

Metric series radial needle roller and cage assemblies are supplied with needle roller complements subdivided into groups (gages) shown in Table B-1. This is in accordance with Grade G2 specified in ISO 3096 standard (see needle rollers, page B-353). The group limits of the needle rollers are indicated on the package. Labels of identifying colors show the group limits of the needle rollers. The needle roller and cage assemblies of one shipment usually contain needle rollers with group limits of between 0.000 to -0.002 mm (0.0000 to -0.00008 in) and -0.005 to -0.007 mm (-0.0002 to -0.0003 in) [colors red, blue and white]. For additional information on needle roller and cage assemblies with needle rollers of different group limits contact your representative.

Table B-1. Needle roller group limits (Grade G2)

Group tolerance		Marking gage	Identifying color on label or on package
mm in	mm in		
0.000 0.0000	-0.002 -0.00008	P0M2	Red
-0.001 -0.00004	-0.003 -0.00012	M1M3	Red
-0.002 -0.00008	-0.004 -0.0002	M2M4	Blue
-0.003 -0.00012	-0.005 -0.0002	M3M5	Blue
-0.004 -0.0002	-0.006 -0.0002	M4M6	White (gray)
-0.005 -0.0002	-0.007 -0.0003	M5M7	White (gray)
-0.006 -0.0002	-0.008 -0.0003	M6M8	Green
-0.007 -0.0003	-0.009 -0.0004	M7M9	Green
-0.008 -0.0003	-0.010 -0.0004	M8M10	Yellow
-0.009 -0.0004	-0.011 -0.0004	M9M11	Yellow

In the marking of the gages, P identifies zero (0) or plus (+), M identifies minus (-).

MOUNTING DIMENSIONS

DESIGN OF RACEWAYS

Radial needle roller and cage assemblies use the housing bore as the outer raceway and the shaft as the inner raceway. To realize full bearing load rating and life, the housing bore and the shaft raceways must have the correct geometric and metallurgical characteristics. The housing should be of sufficient cross section to maintain adequate roundness and running clearance under load. Additional design details for housings and shafts used as outer and inner raceways can be found in the engineering section. The only limit to precision of the radial clearance of a mounted assembly is the capability of the user to hold close tolerances on the inner and outer raceways. The suggested shaft tolerances listed in Table B-2 are based on housing bore tolerance G6 and apply to metric series radial needle roller and cage assemblies with needle rollers of group limits between P0M2 and M5M7.

Table B-2. Suggested shaft tolerances for housing bores machined to G6

Nominal shaft diameter in mm	≤ 80	> 80
Radial clearance	Shaft tolerance	
Smaller than normal	j5	h5
Normal	h5	g5
Larger than normal	g6	f6

AXIAL GUIDANCE REQUIREMENTS

Radial needle roller and cage assembly must be axially guided by shoulders or other suitable means. The end guiding surfaces should be hardened to minimize wear and must provide sufficient axial clearance to prevent end-locking of the assembly. Length tolerance H11 is suggested.

If end guidance is provided by a housing shoulder at one end and by a shaft shoulder at the other end, the shaft must be axially positioned to prevent end-locking of needle roller and cage assembly. The housing and shaft shoulder heights should be 70 percent to 90 percent of the needle roller diameter to provide proper axial guidance.

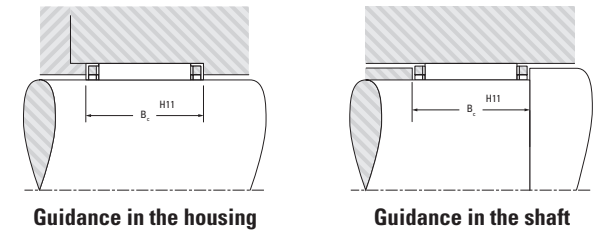

Fig. B-2. Axial guidance requirements

MOUNTING IN SETS

Radial needle roller and cage assemblies that are mounted side by side must have needle rollers of the same group limits to ensure uniform load distribution.

LUBRICATION

Oil is the preferred lubricant for most applications. In critical applications involving high speeds, ample oil flow must be provided. Where assemblies are subjected to high centrifugal forces – such as in epicyclic gearing, or inertia forces, as in the small end of a connecting rod – the contact pressure between the cage and the raceway guiding surface becomes critical. The allowable contact pressure depends on a combination of the induced force and the relative velocity between the cage and raceway and the rate of lubricant flow. Consult your representative when cages will be subjected to high induced forces.

SPECIAL DESIGNS

Radial needle roller and cage assemblies made to special dimensions or configurations – such as those which are split to assemble around a one-piece crankshaft – can be made available on special order. Special coated or plated cages to enhance life, under conditions of marginal lubrication and high induced forces, also can be made available.



SINGLE-ROW,
DOUBLE-ROW
ASSEMBLIES

METRIC SERIES

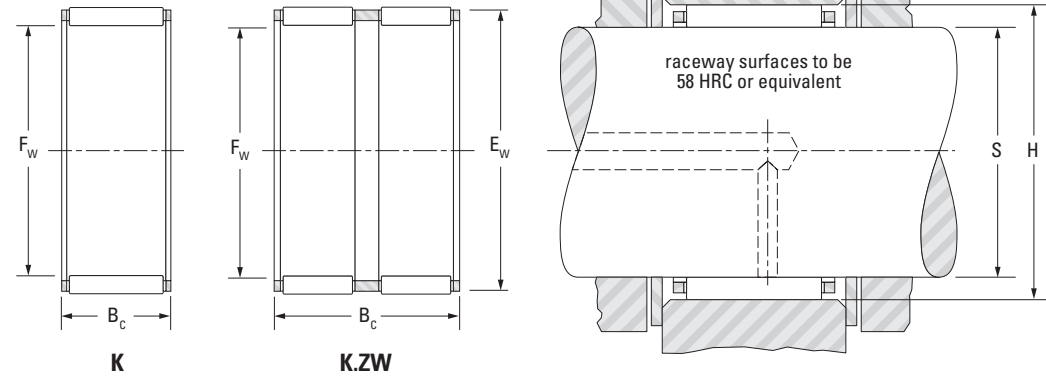

Shaft Dia.	F _w	E _w	B _c	Assembly Designation	C	C ₀	Speed Rating		C _g	S		H		Wt.
							Grease	Oil		Mounting Dimension		Max.	Min.	
										mm in	mm in			
mm in	mm in	mm in	mm in		kN lbf		min ⁻¹		mm in	mm in	mm in	mm in	kg lbs	
3 0.1181	3 0.1181	5 0.1969	7 0.2756	K3X5X7TN	1.56 351	1.29 290	48000	74000	—	3.000 0.1181	2.996 0.1180	5.004 0.1970	5.012 0.1973	0.0002 0.0004
4 0.1575	4 0.1575	7 0.2756	7 0.276	K4X7X7TN	1.83 411	1.32 297	34000	52000	—	4.000 0.1575	3.995 0.1573	7.014 0.2761	7.005 0.2758	0.0005 0.001
5 0.1969	5 0.1969	8 0.3150	8 0.315	K5X8X8TN	2.18 490	1.71 384	31000	47000	—	5.000 0.1969	4.995 0.1967	8.014 0.3155	8.005 0.3152	0.0007 0.002
	5 0.1969	8 0.3150	10 0.394	K5X8X10TN	3.04 683	2.63 591	31000	47000	—	5.000 0.1969	4.995 0.1967	8.014 0.3155	8.005 0.3152	0.0008 0.002
	5 0.1969	9 0.3543	13 0.512	K5X9X13TN	4.29 964	3.55 798	26000	40000	—	5.000 0.1969	4.995 0.1967	9.014 0.3549	9.005 0.3545	0.002 0.004
6 0.2362	6 0.2362	9 0.3543	8 0.315	K6X9X8H	3.19 717	2.90 652	29000	44000	0.0116	6.000 0.2362	5.995 0.2360	9.014 0.3549	9.005 0.3545	0.0008 0.002
	6 0.2362	9 0.3543	8 0.315	K6X9X8TN	2.47 555	2.07 465	29000	44000	—	6.000 0.2362	5.995 0.2360	9.014 0.3549	9.005 0.3545	0.001 0.002
	6 0.2362	9 0.3543	10 0.394	K6X9X10TN	3.07 690	2.74 616	29000	44000	—	6.000 0.2362	5.995 0.2360	9.014 0.3549	9.005 0.3545	0.001 0.002
7 0.2756	7 0.2756	10 0.3937	8 0.315	K7X10X8TN	2.74 616	2.44 549	28000	42000	—	7.000 0.2756	6.994 0.2754	10.014 0.3943	10.005 0.3939	0.001 0.002
	7 0.2756	10 0.3937	10 0.394	K7X10X10TN	3.40 764	3.22 724	28000	42000	—	7.000 0.2756	6.994 0.2754	10.014 0.3943	10.005 0.3939	0.001 0.002
	7 0.2756	11 0.4331	15 0.591	K7X11X15TN	6.44 1450	6.24 1400	23000	35000	—	7.000 0.2756	6.994 0.2754	11.017 0.4337	11.006 0.4333	0.003 0.007
8 0.3150	8 0.3150	11 0.4331	8 0.315	K8X11X8FV	3.23 726	3.11 699	26000	41000	0.0132	8.000 0.3150	7.994 0.3147	11.017 0.4337	11.006 0.4333	0.002 0.004
	8 0.3150	11 0.4331	8 0.315	K8X11X8TN	2.34 526	2.05 461	26000	41000	—	8.000 0.3150	7.994 0.3147	11.017 0.4337	11.006 0.4333	0.001 0.002
	8 0.3150	11 0.4331	10 0.394	K8X11X10H	4.57 1030	4.89 1100	26000	41000	0.0148	8.000 0.3150	7.994 0.3147	11.017 0.4337	11.006 0.4333	0.002 0.004
	8 0.3150	11 0.4331	10 0.394	K8X11X10FV	4.01 901	4.11 924	26000	41000	0.0142	8.000 0.3150	7.994 0.3147	11.017 0.4337	11.006 0.4333	0.002 0.004
	8 0.3150	11 0.4331	10 0.394	K8x11x10TN	3.84 864	3.91 880	26000	41000	—	8.000 0.3150	7.994 0.3147	11.006 0.4333	11.017 0.4337	0.001 0.002
	8 0.3150	11 0.4331	13 0.512	K8x11x13TN	5.18 1170	5.75 1290	26000	41000	—	8.000 0.3150	7.994 0.3147	11.006 0.4333	11.017 0.4337	0.002 0.004

Shaft Dia.	F _w	E _w	B _c	Assembly Designation	C	C ₀	Speed Rating		C _g	S		H		Wt.
							Grease	Oil		Mounting Dimension		Max.	Min.	
										mm in	mm in			
mm in	mm in	mm in	mm in		kN lbf		min ⁻¹		mm in	mm in	mm in	mm in	kg lbs	
8 0.3150	8 0.3150	11 0.4331	13 0.512	K8X11X13H	5.22 1170	5.78 1300	26000	41000	0.0154	8.000 0.3150	7.994 0.3147	11.017 0.4337	11.006 0.4333	0.003 0.007
9 0.3543	9 0.3543	12 0.4724	10 0.394	K9X12X10FH	4.27 960	4.60 1030	26000	40000	0.0153	9.000 0.3543	8.994 0.3541	12.017 0.4731	12.006 0.4727	0.003 0.007
	9 0.3543	12 0.4724	10 0.394	K9X12X10FV	4.27 960	4.60 1030	26000	40000	0.0153	9.000 0.3543	8.994 0.3541	12.017 0.4731	12.006 0.4727	0.002 0.004
	9 0.3543	12 0.4724	13 0.512	K9X12X13FH	5.57 1250	6.47 1450	26000	40000	0.0167	9.000 0.3543	8.994 0.3541	12.017 0.4731	12.006 0.4727	0.003 0.007
	9 0.3543	12 0.4724	13 0.512	K9X12X13FV	5.57 1250	6.47 1450	26000	40000	0.0167	9.000 0.3543	8.994 0.3541	12.017 0.4731	12.006 0.4727	0.003 0.007
	9 0.3543	13 0.5118	8 0.315	K9X13X8H	3.96 890	3.50 787	21000	32000	0.0139	9.000 0.3543	8.994 0.3541	13.017 0.5125	13.006 0.5120	0.003 0.007
10 0.3937	10 0.3937	13 0.5118	10 0.394	K10X13X10H	5.40 1210	6.43 1450	25000	39000	0.0174	10.000 0.3937	9.994 0.3935	13.017 0.5125	13.006 0.5120	0.002 0.004
	10 0.3937	13 0.5118	10 0.394	K10X13X10TN	4.29 964	4.77 1070	25000	39000	—	10.000 0.3937	9.994 0.3935	13.017 0.5125	13.006 0.5120	0.002 0.004
	10 0.3937	13 0.5118	13 0.512	K10X13X13	5.90 1330	7.16 1610	25000	39000	0.0178	10.000 0.3937	9.994 0.3935	13.017 0.5125	13.006 0.5120	0.003 0.007
	10 0.3937	13 0.5118	16 0.630	K10X13X16	7.43 1670	9.64 2170	25000	39000	0.0192	10.000 0.3937	9.994 0.3935	13.017 0.5125	13.006 0.5120	0.004 0.009
	10 0.3937	14 0.5512	10 0.394	K10X14X10H	6.12 1380	6.29 1410	20000	31000	0.0167	10.000 0.3937	9.994 0.3935	14.017 0.5519	14.006 0.5514	0.003 0.007
	10 0.3937	14 0.5512	13 0.512	K10X14X13H	7.88 1770	8.71 1960	20000	31000	0.0181	10.000 0.3937	9.994 0.3935	14.017 0.5519	14.006 0.5514	0.004 0.009
	10 0.3937	16 0.6299	12 0.472	K10X16X12F	8.39 1890	7.47 1680	15000	24000	0.0168	10.000 0.3937	9.994 0.3935	16.017 0.6306	16.006 0.6302	0.006 0.013
	10 0.3937	16 0.6299	12 0.472	K10X16X12TN	7.50 1690	6.40 1440	15000	24000	—	10.000 0.3937	9.994 0.3935	16.017 0.6306	16.006 0.6302	0.005 0.011
12 0.4724	12 0.4724	15 0.5906	10 0.394	K12X15X10H	5.85 1320	7.51 1690	24000	37000	0.0195	12.000 0.4724	11.992 0.4721	15.017 0.5912	15.006 0.5908	0.003 0.007
	12 0.4724	15 0.5906	13 0.512	K12X15X13H	6.78 1520	9.03 2030	24000	37000	0.0204	12.000 0.4724	11.992 0.4721	15.017 0.5912	15.006 0.5908	0.004 0.009
	12 0.4724	16 0.6299	13 0.512	K12X16X13H	7.49 1680	8.51 1910	19000	30000	0.0194	12.000 0.4724	11.992 0.4721	16.017 0.6306	16.006 0.6302	0.006 0.013
	12 0.4724	17 0.6693	13 0.512	K12X17X13	8.93 2010	9.29 2090	16000	25000	0.0194	12.000 0.4724	11.992 0.4721	17.017 0.6700	17.006 0.6695	0.008 0.018
	12 0.4724	18 0.7087	12 0.472	K12X18X12H	9.76 2190	9.40 2110	14000	22000	0.0191	12.000 0.4724	11.992 0.4721	18.017 0.7093	18.006 0.7089	0.009 0.020
13 0.5118	13 0.5118	17 0.6693	10 0.394	K13X17X10	7.22 1620	8.33 1870	19000	29000	0.0199	13.000 0.5118	12.992 0.5115	17.017 0.6700	17.006 0.6695	0.004 0.009
	13 0.5118	18 0.7087	15 0.591	K13X18X15F	10.8 2430	12.1 2720	16000	25000	0.0213	13.000 0.5118	12.992 0.5115	18.017 0.7093	18.006 0.7089	0.008 0.01
14 0.5512	14 0.5512	18 0.7087	8 0.315	K14X18X8	5.39 1210	5.82 1310	19000	29000	0.0188	14.000 0.5512	13.992 0.5509	18.017 0.7093	18.006 0.7089	0.004 0.009
	14 0.5512	18 0.7087	10 0.394	K14X18X10	7.17 1610	8.41 1890	19000	29000	0.0206	14.000 0.5512	13.992 0.5509	18.017 0.7093	18.006 0.7089	0.005 0.011
	14 0.5512	18 0.7087	13 0.512	K14X18X13	9.73 2190	12.5 2810	19000	29000	0.0227	14.000 0.5512	13.992 0.5509	18.017 0.7093	18.006 0.7089	0.006 0.013

Continued on next page.



SINGLE-ROW,
DOUBLE-ROW
ASSEMBLIES –

continued

METRIC SERIES

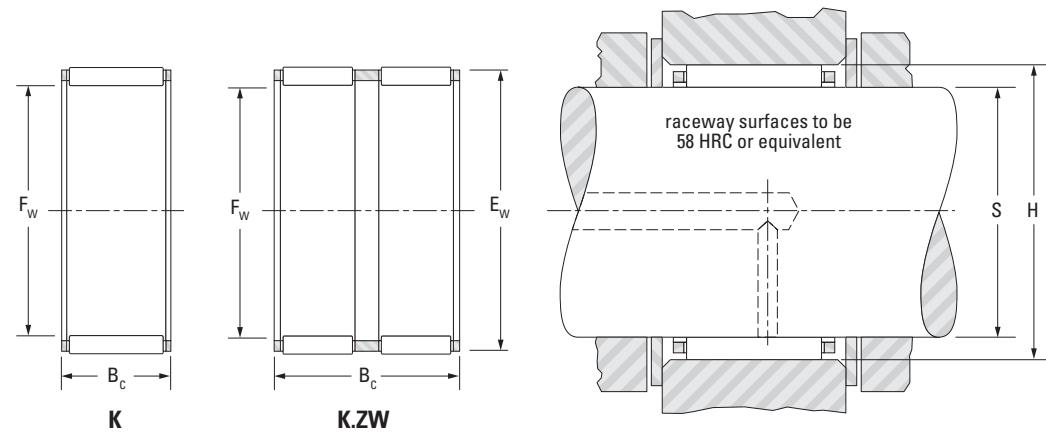

Shaft Dia.	F _w	E _w	B _c -0.20 -0.008 -0.55 -0.022	Assembly Designation	C		Speed Rating		C _g	S				Ht.
					Load Ratings		Grease	Oil		Mounting Dimension				
					kN lbf					min ⁻¹	Max.	Min.	Max.	
mm in	mm in	mm in	mm in		kN	lbf	min ⁻¹	mm in	mm in	mm in	mm in	kg lbs		
14 0.5512	14 0.5512	18 0.7087	15 0.591	K14X18X15	10.5 2360	13.8 3100	19000	29000	0.0233	14.000 0.5512	13.992 0.5509	18.017 0.7093	18.006 0.7089	0.007 0.015
14 0.5512	14 0.5512	18 0.7087	17 0.669	K14X18X17H	12.4 2790	17.1 3840	19000	29000	0.0246	14.000 0.5512	13.992 0.5509	18.017 0.7093	18.006 0.7089	0.008 0.018
14 0.5512	14 0.5512	19 0.7480	13 0.512	K14X19X13H	10.2 2290	11.4 2560	16000	24000	0.0217	14.000 0.5512	13.992 0.5509	19.020 0.7488	19.007 0.7483	0.008 0.018
14 0.5512	14 0.5512	19 0.7480	18 0.709	K14X19X18F	13.2 2970	16.0 3600	16000	24000	0.0236	14.000 0.5512	13.992 0.5509	19.020 0.7488	19.007 0.7483	0.011 0.024
14 0.5512	14 0.5512	20 0.7874	12 0.472	K14X20X12	10.5 2360	10.6 2380	14000	21000	0.0209	14.000 0.5512	13.992 0.5509	20.020 0.7882	20.007 0.7877	0.009 0.020
15 0.5906	15 0.5906	18 0.7087	14 0.551	K15X18X14TN	7.92 1780	11.9 2680	13000	23000	—	15.000 0.5906	14.992 0.5902	18.017 0.7093	18.006 0.7089	0.003 0.007
15 0.5906	15 0.5906	18 0.7087	16 0.630	K15X18X16F	8.36 1880	12.6 2830	13000	23000	0.0244	15.000 0.5906	14.992 0.5902	18.017 0.7093	18.006 0.7089	0.005 0.011
15 0.5906	15 0.5906	18 0.7087	17 0.669	K15X18X17	8.08 1820	12.1 2720	23000	36000	0.0241	15.000 0.5906	14.992 0.5902	18.017 0.7093	18.006 0.7089	0.005 0.011
15 0.5906	15 0.5906	19 0.7480	10 0.394	K15X19X10	7.87 1770	9.69 2180	18000	28000	0.0220	15.000 0.5906	14.992 0.5902	19.020 0.7488	19.007 0.7483	0.005 0.011
15 0.5906	15 0.5906	19 0.7480	13 0.512	K15X19X13	9.66 2170	12.6 2830	18000	28000	0.0235	15.000 0.5906	14.992 0.5902	19.020 0.7488	19.007 0.7483	0.007 0.015
15 0.5906	15 0.5906	19 0.7480	17 0.669	K15X19X17H	12.3 2770	17.2 3870	18000	28000	0.0254	15.000 0.5906	14.992 0.5902	19.020 0.7488	19.007 0.7483	0.009 0.020
15 0.5906	15 0.5906	19 0.7480	22 0.866	K15X19X22ZW	12.2 2740	17.0 3820	18000	28000	0.0253	15.000 0.5906	14.992 0.5902	19.020 0.7488	19.007 0.7483	0.010 0.022
15 0.5906	15 0.5906	20 0.7874	13 0.512	K15X20X13H	9.93 2230	11.3 2540	16000	24000	0.0222	15.000 0.5906	14.992 0.5902	20.020 0.7882	20.007 0.7877	0.008 0.018
15 0.5906	15 0.5906	21 0.8268	15 0.591	K15X21X15	13.4 3010	14.8 3330	14000	21000	0.0233	15.000 0.5906	14.992 0.5902	21.020 0.8276	21.007 0.8270	0.013 0.029
15 0.5906	15 0.5906	21 0.8268	21 0.827	K15X21X21H	18.0 4050	21.7 4880	14000	21000	0.0256	15.000 0.5906	14.992 0.5902	21.020 0.8276	21.007 0.8270	0.018 0.040
16 0.6299	16 0.6299	20 0.7874	8 0.315	K16X20X8F	6.37 1430	7.51 1690	18000	28000	0.0212	16.000 0.6299	15.992 0.6296	20.020 0.7882	20.007 0.7877	0.005 0.011
16 0.6299	16 0.6299	20 0.7874	10 0.394	K16X20X10H	7.82 1760	9.76 2190	18000	28000	0.0226	16.000 0.6299	15.992 0.6296	20.020 0.7882	20.007 0.7877	0.006 0.013

Shaft Dia.	F _w	E _w	B _c -0.20 -0.008 -0.55 -0.022	Assembly Designation	C		Speed Rating		C _g	S				Ht.
					Load Ratings		Grease	Oil		Mounting Dimension				
					kN lbf					min ⁻¹	Max.	Min.	Max.	
mm in	mm in	mm in	mm in		kN	lbf	min ⁻¹	mm in	mm in	mm in	mm in	kg lbs		
16 0.6299	16 0.6299	20 0.7874	13 0.512	K16X20X13	10.1 2270	13.5 3030	18000	28000	0.0245	16.000 0.6299	15.992 0.6296	20.020 0.7882	20.007 0.7877	0.007 0.015
16 0.6299	16 0.6299	20 0.7874	14 0.551	K16X20X14	10.8 2430	14.8 3330	18000	28000	0.0251	16.000 0.6299	15.992 0.6296	20.020 0.7882	20.007 0.7877	0.007 0.015
16 0.6299	16 0.6299	20 0.7874	17 0.669	K16X20X17H	12.9 2900	18.5 4160	18000	28000	0.0265	16.000 0.6299	15.992 0.6296	20.020 0.7882	20.007 0.7877	0.008 0.018
16 0.6299	16 0.6299	20 0.7874	20 0.787	K16X20X20	13.4 3010	19.5 4380	18000	28000	0.0269	16.000 0.6299	15.992 0.6296	20.020 0.7882	20.007 0.7877	0.011 0.024
16 0.6299	16 0.6299	22 0.8661	12 0.472	K16X22X12	11.2 2520	11.9 2680	19000	29000	0.0227	16.000 0.6299	15.992 0.6296	22.020 0.8669	22.007 0.8664	0.010 0.022
16 0.6299	16 0.6299	22 0.8661	16 0.630	K16X22X16H	14.9 3350	17.2 3870	19000	29000	0.0248	16.000 0.6299	15.992 0.6296	22.020 0.8669	22.007 0.8664	0.014 0.031
16 0.6299	16 0.6299	22 0.8661	20 0.787	K16X22X20	18.6 4180	22.9 5150	19000	29000	0.0267	16.000 0.6299	15.992 0.6296	22.020 0.8669	22.007 0.8664	0.017 0.037
16 0.6299	16 0.6299	24 0.9449	20 0.787	K16X24X20	20.2 4540	21.4 4810	20000	30000	0.0255	16.000 0.6299	15.992 0.6296	24.020 0.9457	24.007 0.9452	0.025 0.055
17 0.6693	17 0.6693	20 0.7874	10 0.394	K17X20X10	5.96 1340	8.53 1920	16000	25000	0.0234	17.000 0.6693	16.992 0.6690	20.020 0.7882	20.007 0.7877	0.004 0.009
17 0.6693	17 0.6693	21 0.8268	10 0.394	K17X21X10	8.12 1830	10.4 2340	17000	26000	0.0236	17.000 0.6693	16.992 0.6690	21.020 0.8276	21.007 0.8270	0.006 0.013
17 0.6693	17 0.6693	21 0.8268	12.8 0.504	K17X21X13H	10.5 2360	14.5 3260	17000	26000	0.0256	17.000 0.6693	16.992 0.6690	21.020 0.8276	21.007 0.8270	0.008 0.018
17 0.6693	17 0.6693	21 0.8268	15 0.591	K17X21X15	11.4 2560	16.1 3620	17000	26000	0.0263	17.000 0.6693	16.992 0.6690	21.020 0.8276	21.007 0.8270	0.008 0.018
17 0.6693	17 0.6693	21 0.8268	17 0.669	K17X21X17H	13.4 3010	19.8 4450	17000	26000	0.0277	17.000 0.6693	16.992 0.6690	21.020 0.8276	21.007 0.8270	0.011 0.024
17 0.6693	17 0.6693	22 0.8661	20 0.787	K17X22X20FH	17.0 3820	23.3 5240	17000	27000	0.0280	17.000 0.6693	16.992 0.6690	22.020 0.8669	22.007 0.8664	0.015 0.033
17 0.6693	17 0.6693	23 0.9055	15 0.591	K17X23X15F	14.1 3170	16.3 3660	18000	27000	0.0251	17.000 0.6693	16.992 0.6690	23.020 0.9063	23.007 0.9058	0.010 0.022
18 0.7087	18 0.7087	22 0.8661	8 0.315	K18X22X8F	6.32 1420	7.70 1730	16000	24000	0.0224	18.000 0.7087	17.992 0.7083	22.020 0.8669	22.007 0.8664	0.005 0.011
18 0.7087	18 0.7087	22 0.8661	10 0.394	K18X22X10H	8.41 1890	11.1 2500	16000	24000	0.0246	18.000 0.7087	17.992 0.7083	22.020 0.8669	22.007 0.8664	0.006 0.013
18 0.7087	18 0.7087	22 0.8661	13 0.512	K18X22X13H	10.8 2430	15.4 3460	16000	24000	0.0266	18.000 0.7087	17.992 0.7083	22.020 0.8669	22.007 0.8664	0.008 0.018
18 0.7087	18 0.7087	22 0.8661	14 0.551	K18X22X14	11.6 2610	16.8 3780	16000	24000	0.0272	18.000 0.7087	17.992 0.7083	22.020 0.8669	22.007 0.8664	0.009 0.020
18 0.7087	18 0.7087	22 0.8661	14 0.551	K18X22X14FV	11.3 2540	16.3 3660	16000	24000	0.0270	18.000 0.7087	17.992 0.7083	22.020 0.8669	22.007 0.8664	0.009 0.020
18 0.7087	18 0.7087	22 0.8661	17 0.669	K18X22X17H	13.3 2990	19.9 4470	16000	24000	0.0284	18.000 0.7087	17.992 0.7083	22.020 0.8669	22.007 0.8664	0.009 0.020
18 0.7087	18 0.7087	22 0.8661	20 0.787	K18X22X20F	15.0 3370	23.4 5260	16000	24000	0.0296	18.000 0.7087	17.992 0.7083	22.020 0.8669	22.007 0.8664	0.011 0.024
18 0.7087	18 0.7087	24 0.9449	12 0.472	K18X24X12	11.8 2650	13.1 2940	17000	25000	0.0243	18.000 0.7087	17.992 0.7083	24.020 0.9457	24.007 0.9452	0.011 0.024
18 0.7087	18 0.7087	24 0.9449	20 0.787	K18X24X20H	19.4 4360	24.9 5600	16000	25000	0.0285	18.000 0.7087	17.992 0.7083	24.020 0.9457	24.007 0.9452	0.019 0.042

Continued on next page.



**SINGLE-ROW,
DOUBLE-ROW
ASSEMBLIES –**

continued

METRIC SERIES

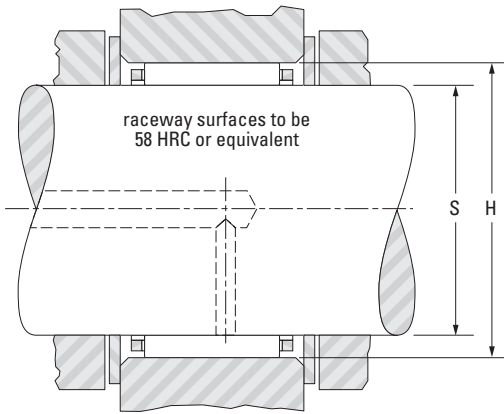
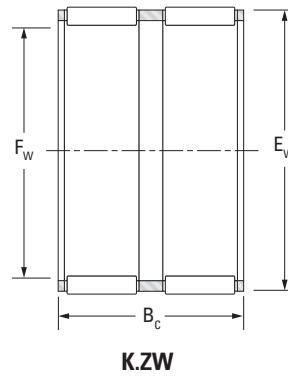
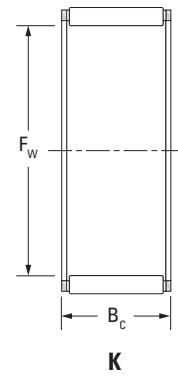

Shaft Dia.	F _w	E _w	B _c -0.20 -0.008 -0.55 -0.022	Assembly Designation	C		Speed Rating		C _g	S				H	Wt.
					Load Ratings		Grease	Oil		Mounting Dimension					
					kN lbf					min ⁻¹	Max.	Min.	Max.		
18 0.7087	18 0.7087	25 0.9843	22 0.866	K18X25X22H	23.3 5240	28.6 6430	17000	26000	0.0291	18.000 0.7087	17.992 0.7083	25.020 0.9850	25.007 0.9845	0.025 0.055	
18 0.7087	18 0.7087	26 1.0236	12 0.472	K18X26X12FV	13.8 3100	13.5 3030	11000	17000	0.0238	18.000 0.7087	17.992 0.7083	26.020 1.0244	26.007 1.0239	0.020 0.044	
18 0.7087	18 0.7087	26 1.0236	20 0.787	K18X26X20F	21.7 4880	24.1 5420	17000	26000	0.0275	18.000 0.7087	17.992 0.7083	26.020 1.0244	26.007 1.0239	0.027 0.060	
19 0.7480	19 0.7480	23 0.9055	13 0.512	K19X23X13	10.8 2430	15.5 3480	15000	23000	0.0273	19.000 0.7480	18.991 0.7477	23.020 0.9063	23.007 0.9058	0.008 0.018	
19 0.7480	19 0.7480	23 0.9055	17 0.669	K19X23X17	13.4 3010	20.6 4630	15000	23000	0.0293	19.000 0.7480	18.991 0.7477	23.020 0.9063	23.007 0.9058	0.011 0.024	
20 0.7874	20 0.7874	24 0.9449	8 0.315	K20X24X8F	7.31 1640	9.60 2160	14000	22000	0.0248	20.000 0.7874	19.991 0.7870	24.020 0.9457	24.007 0.9452	0.005 0.011	
20 0.7874	20 0.7874	24 0.9449	10 0.394	K20X24X10H	8.97 2020	12.5 2810	14000	22000	0.0265	20.000 0.7874	19.991 0.7870	24.020 0.9457	24.007 0.9452	0.006 0.013	
20 0.7874	20 0.7874	24 0.9449	12 0.472	K20X24X12	10.7 2410	15.7 3530	14000	22000	0.0280	20.000 0.7874	19.991 0.7870	24.020 0.9457	24.007 0.9452	0.008 0.018	
20 0.7874	20 0.7874	24 0.9449	13 0.512	K20X24X13H	11.5 2590	17.3 3890	14000	22000	0.0287	20.000 0.7874	19.991 0.7870	24.020 0.9457	24.007 0.9452	0.009 0.020	
20 0.7874	20 0.7874	24 0.9449	14 0.551	K20X24X14	12.4 2790	18.9 4250	14000	22000	0.0293	20.000 0.7874	19.991 0.7870	24.020 0.9457	24.007 0.9452	0.009 0.020	
20 0.7874	20 0.7874	24 0.9449	17 0.669	K20X24X17H	14.8 3330	23.7 5330	14000	22000	0.0310	20.000 0.7874	19.991 0.7870	24.020 0.9457	24.007 0.9452	0.011 0.024	
20 0.7874	20 0.7874	26 1.0236	12 0.472	K20X26X12	13.0 2920	15.3 3440	15000	23000	0.0264	20.000 0.7874	19.991 0.7870	26.020 1.0244	26.007 1.0239	0.012 0.026	
20 0.7874	20 0.7874	26 1.0236	13 0.512	K20X26X13H	13.4 3010	15.9 3570	15000	23000	0.0267	20.000 0.7874	19.991 0.7870	26.020 1.0244	26.007 1.0239	0.014 0.031	
20 0.7874	20 0.7874	26 1.0236	17 0.669	K20X26X17H	19.3 4340	25.5 5730	15000	23000	0.0300	20.000 0.7874	19.991 0.7870	26.020 1.0244	26.007 1.0239	0.017 0.037	
20 0.7874	20 0.7874	26 1.0236	20 0.787	K20X26X20	20.3 4560	27.2 6110	15000	23000	0.0305	20.000 0.7874	19.991 0.7870	26.020 1.0244	26.007 1.0239	0.020 0.044	
20 0.7874	20 0.7874	28 1.1024	20 0.787	K20X28X20H	24.6 5530	29.0 6520	15000	23000	0.0300	20.000 0.7874	19.991 0.7870	28.020 1.1031	28.007 1.1026	0.028 0.062	
20 0.7874	20 0.7874	28 1.1024	25 0.984	K20X28X25H	29.7 6680	37.0 8320	15000	23000	0.0319	20.000 0.7874	19.991 0.7870	28.020 1.1031	28.007 1.1026	0.036 0.079	

Shaft Dia.	F _w	E _w	B _c -0.20 -0.008 -0.55 -0.022	Assembly Designation	C		Speed Rating		C _g	S				H	Wt.
					Load Ratings		Grease	Oil		Mounting Dimension					
					kN lbf					min ⁻¹	Max.	Min.	Max.		
20 0.7874	20 0.7874	30 1.1811	30 1.181	K20X30X30H	38.9 8750	45.8 10300	16000	24000	0.0329	20.000 0.7874	19.991 0.7870	30.020 1.1819	30.007 1.1814	0.055 0.121	
	20 0.7874	32 1.2598	36 1.417	K20X32X36H	49.9 11220	57.0 12810	16000	25000	0.0344	20.000 0.7874	19.991 0.7870	32.025 1.2608	32.009 1.2602	0.082 0.181	
21 0.8268	21 0.8268	25 0.9843	17 0.669	K21X25X17H	14.3 3210	23.1 5190	14000	21000	0.0315	21.000 0.8268	20.991 0.8264	25.020 0.9850	25.007 0.9845	0.013 0.029	
22 0.8661	22 0.8661	26 1.0236	10 0.394	K22X26X10H	9.81 2210	14.5 3260	13000	20000	0.0291	22.000 0.8661	21.991 0.8658	26.020 1.0244	26.007 1.0239	0.007 0.015	
	22 0.8661	26 1.0236	13 0.512	K22X26X13H	11.8 2650	18.3 4110	13000	20000	0.0303	22.000 0.8661	21.991 0.8658	26.020 1.0244	26.007 1.0239	0.012 0.026	
	22 0.8661	26 1.0236	17 0.669	K22X26X17H	15.6 3510	26.3 5910	13000	20000	0.0332	22.000 0.8661	21.991 0.8658	26.020 1.0244	26.007 1.0239	0.012 0.026	
	22 0.8661	26 1.0236	18 0.709	K22X26X18H	15.3 3440	25.5 5730	13000	20000	0.0329	22.000 0.8661	21.991 0.8658	26.020 1.0244	26.007 1.0239	0.017 0.037	
	22 0.8661	28 1.1024	13 0.512	K22X28X13	13.9 3120	17.1 3840	13000	20000	0.0283	22.000 0.8661	21.991 0.8658	28.020 1.1031	28.007 1.1026	0.015 0.033	
	22 0.8661	28 1.1024	17 0.669	K22X28X17H	18.2 4090	24.2 5440	13000	20000	0.0308	22.000 0.8661	21.991 0.8658	28.020 1.1031	28.007 1.1026	0.020 0.044	
	22 0.8661	30 1.1811	15 0.591	K22X30X15H	19.7 4430	22.3 5010	14000	21000	0.0292	22.000 0.8661	21.991 0.8658	30.020 1.1819	30.007 1.1814	0.023 0.051	
	22 0.8661	30 1.1811	20 0.787	K22X30X20FV	24.4 5490	29.4 6610	14000	21000	0.0313	22.000 0.8661	21.991 0.8658	30.020 1.1819	30.007 1.1814	0.031 0.068	
	22 0.8661	32 1.2598	24 0.945	K22X32X24F	33.1 7440	37.9 8520	14000	22000	0.0326	22.000 0.8661	21.991 0.8658	32.025 1.2608	32.009 1.2602	0.046 0.101	
	22 0.8661	32 1.2598	30 1.181	K22X32X30H	41.8 9400	51.3 11530	14000	22000	0.0351	22.000 0.8661	21.991 0.8658	32.025 1.2608	32.009 1.2602	0.057 0.126	
23 0.9055	23 0.9055	28 1.1024	24 0.945	K23X28X24F	22.4 5040	36.2 8140	12000	19000	0.0355	23.000 0.9055	22.991 0.9052	28.020 1.1031	28.007 1.1026	0.023 0.051	
	23 0.9055	35 1.3780	16 0.630	K23X35X16H	25.9 5820	25.1 5640	14000	21000	0.0294	23.000 0.9055	22.991 0.9052	35.025 1.3789	35.009 1.3783	0.040 0.088	
24 0.9449	24 0.9449	28 1.1024	10 0.394	K24X28X10H	9.67 2170	14.6 3280	12000	18000	0.0298	24.000 0.9449	23.991 0.9445	28.020 1.1031	28.007 1.1026	0.027 0.060	
	24 0.9449	28 1.1024	13 0.512	K24X28X13H	12.5 2810	20.2 4540	12000	18000	0.0323	24.000 0.9449	23.991 0.9445	28.020 1.1031	28.007 1.1026	0.010 0.022	
	24 0.9449	28 1.1024	16 0.630	K24X28X16F						24.000 0.9449	23.991 0.9445	28.020 1.1031	28.007 1.1026		
	24 0.9449	28 1.1024	17 0.669	K24X28X17H	15.4 3460	26.4 5930	12000	18000	0.0345	24.000 0.9449	23.991 0.9445	28.020 1.1031	28.007 1.1026	0.013 0.029	
	24 0.9449	30 1.1811	10 0.394	K24X30X10TN	11.3 2540	13.5 3030	12000	19000	—	24.000 0.9449	23.991 0.9445	30.020 1.1819	30.007 1.1814	0.008 0.018	
	24 0.9449	30 1.1811	17 0.669	K24X30X17H	19.8 4450	27.7 6230	12000	19000	0.0331	24.000 0.9449	23.991 0.9445	30.020 1.1819	30.007 1.1814	0.020 0.044	
	24 0.9449	30 1.1811	22 0.866	K24X30X22	25.0 5620	37.3 8390	12000	19000	0.0356	24.000 0.9449	23.991 0.9445	30.020 1.1819	30.007 1.1814	0.024 0.053	
	24 0.9449	36 1.4173	23 0.906	K24X36X23H	37.1 8340	40.1 9010	13000	20000	0.0336	24.000 0.9449	23.991 0.9445	36.025 1.4183	36.009 1.4177	0.070 0.154	
25 0.9843	25 0.9843	29 1.1417	10 0.394	K25X29X10H	9.61 2160	14.6 3280	11000	17000	0.0303	25.000 0.9843	24.991 0.9839	29.020 1.1425	29.007 1.1420	0.008 0.018	

Continued on next page.



**SINGLE-ROW,
DOUBLE-ROW
ASSEMBLIES –**

continued

METRIC SERIES

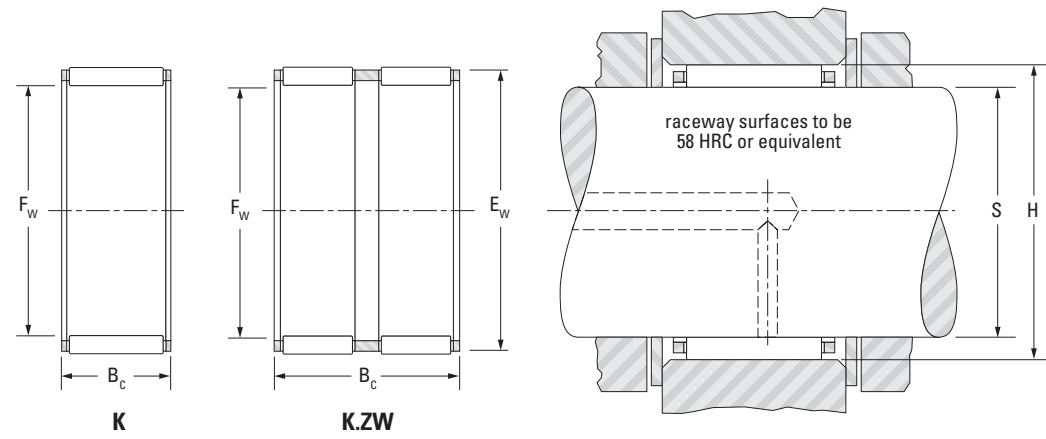

Shaft Dia.	F _w	E _w	B _c -0.20 -0.008 -0.55 -0.022	Assembly Designation	C		Speed Rating		C _g	S				Ht.
					Load Ratings		Grease	Oil		Mounting Dimension				
					kN lbf					min ⁻¹	Max.	Min.	Max.	
mm in	mm in	mm in	mm in		kN lbf	min ⁻¹		mm in	mm in	mm in	mm in	mm in	kg lbs	
25 0.9843	25 0.9843	29 1.1417	13 0.512	K25X29X13H	12.8 2880	21.1 4740	11000	17000	0.0332	25.000 0.9843	24.991 0.9839	29.020 1.1425	29.007 1.1420	0.010 0.022
25 0.9843	25 0.9843	29 1.1417	17 0.669	K25X29X17H	15.1 3390	26.2 5890	11000	17000	0.0351	25.000 0.9843	24.991 0.9839	29.020 1.1425	29.007 1.1420	0.016 0.035
25 0.9843	25 0.9843	30 1.1811	13 0.512	K25X30X13	14.6 3280	21.4 4810	11000	17000	0.0323	25.000 0.9843	24.991 0.9839	30.020 1.1819	30.007 1.1814	0.012 0.026
25 0.9843	25 0.9843	30 1.1811	17 0.669	K25X30X17H	18.8 4230	29.8 6700	11000	17000	0.0351	25.000 0.9843	24.991 0.9839	30.020 1.1819	30.007 1.1814	0.016 0.035
25 0.9843	25 0.9843	30 1.1811	18 0.709	K25X30X18	20.6 4630	33.4 7510	11000	17000	0.0361	25.000 0.9843	24.991 0.9839	30.020 1.1819	30.007 1.1814	0.017 0.037
25 0.9843	25 0.9843	30 1.1811	20 0.787	K25X30X20H	21.9 4920	36.1 8120	11000	17000	0.0368	25.000 0.9843	24.991 0.9839	30.020 1.1819	30.007 1.1814	0.019 0.042
25 0.9843	25 0.9843	30 1.1811	24 0.945	K25X30X24H	24.8 5580	42.4 9530	11000	17000	0.0383	25.000 0.9843	24.991 0.9839	30.020 1.1819	30.007 1.1814	0.024 0.053
25 0.9843	25 0.9843	30 1.1811	26 1.024	K25X30X26ZW	23.0 5170	38.6 8680	11000	17000	0.0374	25.000 0.9843	24.991 0.9839	30.020 1.1819	30.007 1.1814	0.027 0.060
25 0.9843	25 0.9843	31 1.2205	14 0.551	K25X31X14H	16.8 3780	22.7 5100	12000	18000	0.0320	25.000 0.9843	24.991 0.9839	31.025 1.2215	31.009 1.2208	0.017 0.037
25 0.9843	25 0.9843	31 1.2205	17 0.669	K25X31X17H	19.7 4430	27.8 6250	12000	18000	0.0337	25.000 0.9843	24.991 0.9839	31.025 1.2215	31.009 1.2208	0.020 0.044
25 0.9843	25 0.9843	31 1.2205	21 0.827	K25X31X21H	25.1 5640	38.0 8540	12000	18000	0.0364	25.000 0.9843	24.991 0.9839	31.025 1.2215	31.009 1.2208	0.026 0.057
25 0.9843	25 0.9843	31 1.2205	24 0.945	K25X31X24FH	25.3 5690	38.5 8660	12000	18000	0.0365	25.000 0.9843	24.991 0.9839	31.025 1.2215	31.009 1.2208	0.031 0.068
25 0.9843	25 0.9843	32 1.2598	16 0.630	K25X32X16	19.8 4450	25.3 5690	12000	18000	0.0323	25.000 0.9843	24.991 0.9839	32.025 1.2608	32.009 1.2602	0.027 0.060
25 0.9843	25 0.9843	33 1.2992	20 0.787	K25X33X20H	28.8 6470	37.6 8450	12000	18000	0.0350	25.000 0.9843	24.991 0.9839	33.025 1.3002	33.009 1.2996	0.035 0.077
25 0.9843	25 0.9843	33 1.2992	24 0.945	K25X33X24H	32.3 7260	43.5 9780	12000	18000	0.0363	25.000 0.9843	24.991 0.9839	33.025 1.3002	33.009 1.2996	0.038 0.084
25 0.9843	25 0.9843	33 1.2992	25 0.984	K25X33X25H	33.0 7420	44.6 10030	12000	18000	0.0365	25.000 0.9843	24.991 0.9839	33.025 1.3002	33.009 1.2996	0.041 0.090
25 0.9843	25 0.9843	35 1.3780	23.7 0.933	K25X35X23.7H	35.9 8070	42.3 9510	12000	19000	0.0354	25.000 0.9843	24.991 0.9839	35.025 1.3789	35.009 1.3783	0.050 0.110

Shaft Dia.	F _w	E _w	B _c -0.20 -0.008 -0.55 -0.022	Assembly Designation	C		Speed Rating		C _g	S				Ht.
					Load Ratings		Grease	Oil		Mounting Dimension				
					kN lbf					min ⁻¹	Max.	Min.	Max.	
mm in	mm in	mm in	mm in		kN lbf	min ⁻¹		mm in	mm in	mm in	mm in	mm in	kg lbs	
25 0.9843	25 0.9843	35 1.3780	25 0.984	K25X35X25H	37.8 8500	46.2 10390	12000	19000	0.0360	25.000 0.9843	24.991 0.9839	35.025 1.3789	35.009 1.3783	0.054 0.119
	25 0.9843	35 1.3780	30 1.181	K25X35X30H	44.6 10030	57.2 12860	12000	19000	0.0379	25.000 0.9843	24.991 0.9839	35.025 1.3789	35.009 1.3783	0.060 0.132
	25 0.9843	35 1.3780	36 1.417	K25X35X36H	52.4 11780	70.4 15830	12000	19000	0.0399	25.000 0.9843	24.991 0.9839	35.025 1.3789	35.009 1.3783	0.074 0.163
	25 0.9843	37 1.4567	20 0.787	K25X37X20H	32.5 7310	34.1 7670	12000	19000	0.0328	25.000 0.9843	24.991 0.9839	37.025 1.4577	37.009 1.4570	0.055 0.121
26 1.0236	26 1.0236	30 1.1811	10 0.394	K26X30X10F	9.46 2130	14.5 3260	11000	16000	0.0308	26.000 1.0236	25.991 1.0233	30.020 1.1819	30.007 1.1814	0.007 0.015
	26 1.0236	30 1.1811	13 0.512	K26X30X13	12.3 2770	20.4 4590	10000	16000	0.0335	26.000 1.0236	25.991 1.0233	30.020 1.1819	30.007 1.1814	0.011 0.024
	26 1.0236	30 1.1811	17 0.669	K26X30X17	15.0 3370	26.3 5910	10000	16000	0.0357	26.000 1.0236	25.991 1.0233	30.020 1.1819	30.007 1.1814	0.014 0.031
	26 1.0236	30 1.1811	22 0.866	K26X30X22ZW	16.7 3750	30.2 6790	10000	16000	0.0370	26.000 1.0236	25.991 1.0233	30.020 1.1819	30.007 1.1814	0.018 0.040
28 1.1024	28 1.1024	32 1.2598	21 0.827	K28X32X21F	18.7 4200	35.7 8030	9900	15000	0.0398	28.000 1.1024	27.991 1.1020	32.025 1.2608	32.009 1.2602	0.018 0.040
	28 1.1024	33 1.2992	13 0.512	K28X33X13F	14.1 3170	21.4 4810	10000	15000	0.0339	28.000 1.1024	27.991 1.1020	33.025 1.3002	33.009 1.2996	0.015 0.033
	28 1.1024	33 1.2992	17 0.669	K28X33X17H	19.8 4450	33.0 7420	10000	15000	0.0378	28.000 1.1024	27.991 1.1020	33.025 1.3002	33.009 1.2996	0.018 0.040
	28 1.1024	33 1.2992	27 1.063	K28X33X27	29.0 6520	53.8 12090	10000	15000	0.0427	28.000 1.1024	27.991 1.1020	33.025 1.3002	33.009 1.2996	0.027 0.060
	28 1.1024	34 1.3386	17 0.669	K28X34X17	21.1 4740	31.5 7080	10000	16000	0.0364	28.000 1.1024	27.991 1.1020	34.025 1.3396	34.009 1.3389	0.022 0.049
	28 1.1024	34 1.3386	20 0.787	K28X34X20H	24.4 5490	37.8 8500	10000	16000	0.0381	28.000 1.1024	27.991 1.1020	34.025 1.3396	34.009 1.3389	0.025 0.055
	28 1.1024	35 1.3780	15 0.591	K28X35X15H	19.5 4380	25.6 5760	10000	16000	0.0339	28.000 1.1024	27.991 1.1020	35.025 1.3789	35.009 1.3783	0.025 0.055
	28 1.1024	35 1.3780	16 0.630	K28X35X16H	21.5 4830	29.1 6540	10000	16000	0.0350	28.000 1.1024	27.991 1.1020	35.025 1.3789	35.009 1.3783	0.026 0.057
	28 1.1024	35 1.3780	27 1.063	K28X35X27H	35.2 7910	54.7 12300	10000	16000	0.0409	28.000 1.1024	27.991 1.1020	35.025 1.3789	35.009 1.3783	0.042 0.093
	28 1.1024	36 1.4173	20 0.787	K28X36X20FV	27.8 6250	37.0 8320	10000	16000	0.0365	28.000 1.1024	27.991 1.1020	36.025 1.4183	36.009 1.4177	0.039 0.086
	28 1.1024	38 1.4961	25 1.004	K28X38X25.5	40.9 9190	52.7 11850	11000	16000	0.0389	28.000 1.1024	27.991 1.1020	38.025 1.4970	38.009 1.4964	0.059 0.130
	28 1.1024	40 1.5748	18 0.709	K28X40X18H	33.6 7550	36.5 8210	11000	17000	0.0349	28.000 1.1024	27.991 1.1020	40.025 1.5758	40.009 1.5752	0.060 0.132
	28 1.1024	40 1.5748	25 0.984	K28X40X25H	45.5 10230	54.0 12140	11000	17000	0.0384	28.000 1.1024	27.991 1.1020	40.025 1.5758	40.009 1.5752	0.072 0.159
	28 1.1024	40 1.5748	30 1.181	K28X40X30H	54.3 12210	67.8 15240	11000	17000	0.0406	28.000 1.1024	27.991 1.1020	40.025 1.5758	40.009 1.5752	0.100 0.220
	28 1.1024	41 1.6142	25 0.984	K28X41X25H	49.2 11060	57.1 12840	11000	17000	0.0386	28.000 1.1024	27.991 1.1020	41.025 1.6152	41.009 1.6145	0.082 0.181
29 1.1417	29 1.1417	34 1.3386	27 1.063	K29X34X27F	28.9 6500	54.0 12140	9700	15000	0.0434	29.000 1.1417	28.991 1.1414	34.025 1.3396	34.009 1.3389	0.033 0.073

Continued on next page.



**SINGLE-ROW,
DOUBLE-ROW
ASSEMBLIES –**

continued

METRIC SERIES

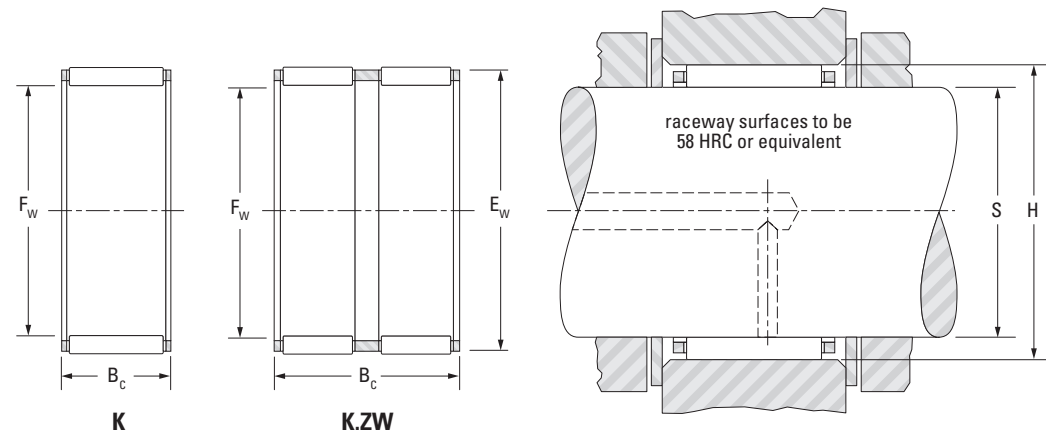

Shaft Dia.	F _w	E _w	B _c	Assembly Designation	C	C ₀	Speed Rating		C _g	S		H		Wt.
							Grease	Oil		Mounting Dimension		Max.	Min.	
										Max.	Min.			
mm in	mm in	mm in	mm in		kN lbf		min ⁻¹		mm in	mm in	mm in	mm in	kg lbs	
30 1.1811	30 1.1811	34 1.3386	13 0.512	K30X34X13	13.5 3030	24.1 5420	9200	14000	0.0372	30.000 1.1811	29.991 1.1807	34.025 1.3396	34.009 1.3389	0.011 0.024
30 1.1811	30 1.1811	35 1.3780	13 0.512	K30X35X13H	15.6 3510	24.9 5600	9300	14000	0.0363	30.000 1.1811	29.991 1.1807	35.025 1.3789	35.009 1.3783	0.017 0.037
30 1.1811	30 1.1811	35 1.3780	17 0.669	K30X35X17H	20.2 4540	34.6 7780	9300	14000	0.0394	30.000 1.1811	29.991 1.1807	35.025 1.3789	35.009 1.3783	0.022 0.049
30 1.1811	30 1.1811	35 1.3780	20 0.787	K30X35X20H	23.5 5280	41.9 9420	9300	14000	0.0413	30.000 1.1811	29.991 1.1807	35.025 1.3789	35.009 1.3783	0.023 0.051
30 1.1811	30 1.1811	35 1.3780	22.8 0.898	K30X35X23F	25.6 5760	46.8 10520	9300	14000	0.0425	30.000 1.1811	29.991 1.1807	35.025 1.3789	35.009 1.3783	0.028 0.062
30 1.1811	30 1.1811	35 1.3780	27 1.063	K30X35X27H	30.6 6880	59.0 13260	9300	14000	0.0450	30.000 1.1811	29.991 1.1807	35.025 1.3789	35.009 1.3783	0.032 0.071
30 1.1811	30 1.1811	35 1.3780	27 1.063	K30X35X27HZW	19.9 4470	33.6 7550	9300	14000	0.0391	30.000 1.1811	29.991 1.1807	35.025 1.3789	35.009 1.3783	0.033 0.073
30 1.1811	30 1.1811	36 1.4173	14 0.551	K30X36X14	18.0 4050	26.2 5890	9500	15000	0.0358	30.000 1.1811	29.991 1.1807	36.025 1.4183	36.009 1.4177	0.020 0.044
30 1.1811	30 1.1811	37 1.4567	17.8 0.701	K30X37X18	24.3 5460	34.8 7820	9600	15000	0.0377	30.000 1.1811	29.991 1.1807	37.025 1.4577	37.009 1.4570	0.033 0.073
30 1.1811	30 1.1811	40 1.5748	30 1.181	K30X40X30H	49.2 11060	67.8 15240	9900	15000	0.0426	30.000 1.1811	29.991 1.1807	40.025 1.5758	40.009 1.5752	0.077 0.170
30 1.1811	30 1.1811	42 1.6535	30 1.181	K30X42X30H	54.2 12180	68.6 15420	10000	16000	0.0419	30.000 1.1811	29.991 1.1807	42.025 1.6545	42.009 1.6539	0.096 0.212
30 1.1811	30 1.1811	44 1.7323	26 1.024	K30X44X26H	52.4 11780	59.9 13470	10000	16000	0.0399	30.000 1.1811	29.991 1.1807	44.025 1.7333	44.009 1.7326	0.095 0.209
32 1.2598	32 1.2598	36 1.4173	15 0.591	K32X36X15F	11.6 2610	20.2 4540	8600	13000	0.0367	32.000 1.2598	31.989 1.2594	36.025 1.4183	36.009 1.4177	0.015 0.033
32 1.2598	32 1.2598	37 1.4567	13 0.512	K32X37X13	15.2 3420	24.4 5490	8700	13000	0.0372	32.000 1.2598	31.989 1.2594	37.025 1.4577	37.009 1.4570	0.018 0.040
32 1.2598	32 1.2598	37 1.4567	17 0.669	K32X37X17H	20.0 4500	34.8 7820	8700	13000	0.0406	32.000 1.2598	31.989 1.2594	37.025 1.4577	37.009 1.4570	0.020 0.044
32 1.2598	32 1.2598	37 1.4567	27 1.063	K32X37X27	29.3 6590	56.8 12770	8700	13000	0.0459	32.000 1.2598	31.989 1.2594	37.025 1.4577	37.009 1.4570	0.035 0.077
32 1.2598	32 1.2598	38 1.4961	20 0.787	K32X38X20H	27.3 6140	45.7 10270	8800	14000	0.0423	32.000 1.2598	31.989 1.2594	38.025 1.4970	38.009 1.4964	0.030 0.066

Shaft Dia.	F _w	E _w	B _c	Assembly Designation	C	C ₀	Speed Rating		C _g	S		H		Wt.
							Grease	Oil		Mounting Dimension		Max.	Min.	
										Max.	Min.			
mm in	mm in	mm in	mm in		kN lbf		min ⁻¹		mm in	mm in	mm in	mm in	kg lbs	
32 1.2598	32 1.2598	38 1.4961	26 1.024	K32X38X26H	33.2 7460	58.8 13220	8800	14000	0.0451	32.000 1.2598	31.989 1.2594	38.025 1.4970	38.009 1.4964	0.037 0.082
	32 1.2598	39 1.5354	16 0.630	K32X39X16H	23.0 5170	33.0 7420	8900	14000	0.0382	32.000 1.2598	31.989 1.2594	39.025 1.5364	39.009 1.5358	0.030 0.066
	32 1.2598	39 1.5354	18 0.709	K32X39X18H	25.8 5800	38.2 8590	8900	14000	0.0397	32.000 1.2598	31.989 1.2594	39.025 1.5364	39.009 1.5358	0.033 0.073
	32 1.2598	40 1.5748	25 0.984	K32X40X25H	37.9 8520	57.2 12860	9000	14000	0.0431	32.000 1.2598	31.989 1.2594	40.025 1.5758	40.009 1.5752	0.052 0.115
	32 1.2598	40 1.5748	36 1.417	K32X40X36H	52.3 11760	86.4 19420	9000	14000	0.0477	32.000 1.2598	31.989 1.2594	40.025 1.5758	40.009 1.5752	0.080 0.176
	32 1.2598	42 1.6535	42 1.654	K32X42X42H	69.2 15560	108 24280	9200	14000	0.0491	32.000 1.2598	31.989 1.2594	42.025 1.6545	42.009 1.6539	0.110 0.243
	32 1.2598	46 1.8110	18 0.709	K32X46X18H	39.2 8810	41.9 9420	9600	15000	0.0374	32.000 1.2598	31.989 1.2594	46.025 1.8120	46.009 1.8114	0.075 0.165
	32 1.2598	46 1.8110	32 1.260	K32X46X32H	67.0 15060	83.4 18750	9600	15000	0.0444	32.000 1.2598	31.989 1.2594	46.025 1.8120	46.009 1.8114	0.140 0.309
	32 1.2598	46 1.8110	40 1.575	K32X46X40H	81.7 18370	108 24280	9600	15000	0.0473	32.000 1.2598	31.989 1.2594	46.025 1.8120	46.009 1.8114	0.158 0.348
33 1.2992	33 1.2992	51 2.0079	23 0.906	K33X51X23H	55.9 12570	57.6 12950	9600	15000	0.0401	33.000 1.2992	32.989 1.2988	51.029 2.0090	51.010 2.0083	0.140 0.309
34 1.3386	34 1.3386	38 1.4961	11 0.433	K34X38X11	12.2 2740	21.9 4920	8100	12000	0.0385	34.000 1.3386	33.989 1.3381	38.025 1.4970	38.009 1.4964	0.011 0.024
	34 1.3386	44 1.7323	26 1.024	K34X44X26FH	42.9 9640	58.9 13240	8600	13000	0.0433	34.000 1.3386	33.989 1.3381	44.025 1.7333	44.009 1.7326	0.080 0.176
35 1.3780	35 1.3780	40 1.5748	13 0.512	K35X40X13H	16.2 3640	27.2 6110	7900	12000	0.0398	35.000 1.3780	34.989 1.3775	40.025 1.5758	40.009 1.5752	0.018 0.040
	35 1.3780	40 1.5748	17 0.669	K35X40X17H	22.1 4970	40.8 9170	7900	12000	0.0440	35.000 1.3780	34.989 1.3775	40.025 1.5758	40.009 1.5752	0.025 0.055
	35 1.3780	40 1.5748	19 0.748	K35X40X19H	23.2 5220	43.2 9710	7900	12000	0.0446	35.000 1.3780	34.989 1.3775	40.025 1.5758	40.009 1.5752	0.025 0.055
	35 1.3780	40 1.5748	25 0.984	K35X40X25H	28.4 6380	56.2 12630	7900	12000	0.0476	35.000 1.3780	34.989 1.3775	40.025 1.5758	40.009 1.5752	0.035 0.077
	35 1.3780	40 1.5748	27 1.063	K35X40X27H	29.8 6700	59.6 13400	7900	12000	0.0483	35.000 1.3780	34.989 1.3775	40.025 1.5758	40.009 1.5752	0.037 0.082
	35 1.3780	42 1.6535	16 0.630	K35X42X16AH	24.5 5510	36.8 8270	8100	12000	0.0408	35.000 1.3780	34.989 1.3775	42.025 1.6545	42.009 1.6539	0.031 0.068
	35 1.3780	42 1.6535	18 0.709	K35X42X18	27.5 6180	42.6 9580	8100	12000	0.0423	35.000 1.3780	34.989 1.3775	42.025 1.6545	42.009 1.6539	0.035 0.077
	35 1.3780	42 1.6535	20 0.787	K35X42X20H	30.4 6830	48.5 10900	8100	12000	0.0437	35.000 1.3780	34.989 1.3775	42.025 1.6545	42.009 1.6539	0.037 0.082
	35 1.3780	42 1.6535	30 1.181	K35X42X30FH	40.5 9100	70.0 15740	8100	12000	0.0479	35.000 1.3780	34.989 1.3775	42.025 1.6545	42.009 1.6539	0.061 0.134
	35 1.3780	45 1.7717	20 0.787	K35X45X20FH	36.5 8210	49.9 11220	8400	13000	0.0421	35.000 1.3780	34.989 1.3775	45.025 1.7726	45.009 1.7720	0.059 0.130
	35 1.3780	45 1.7717	30 1.181	K35X45X30F	51.2 11510	74.5 16750	8400	13000	0.0465	35.000 1.3780	34.989 1.3775	45.025 1.7726	45.009 1.7720	0.100 0.220
	35 1.3780	45 1.7717	35 1.378	K35X45X35H	62.1 13960	95.5 21470	8400	13000	0.0494	35.000 1.3780	34.989 1.3775	45.025 1.7726	45.009 1.7720	0.085 0.187

Continued on next page.



**SINGLE-ROW,
DOUBLE-ROW
ASSEMBLIES –**

continued

METRIC SERIES

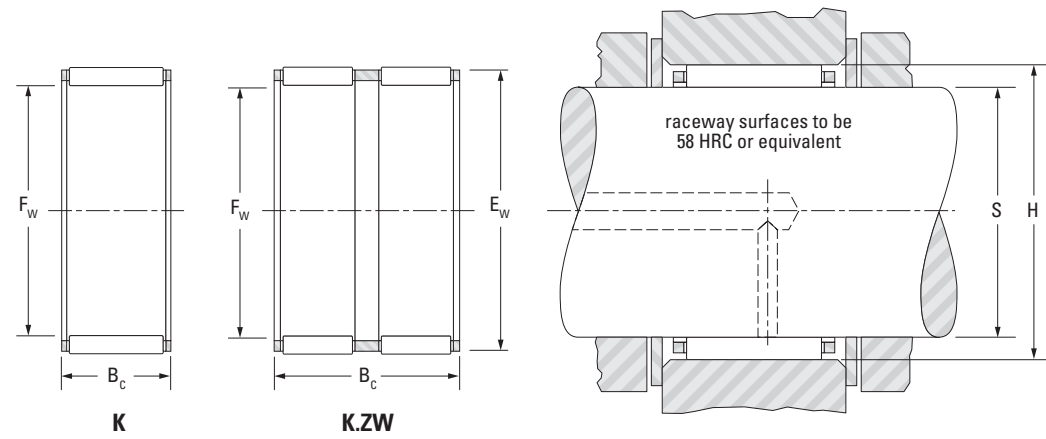

Shaft Dia.	F _w	E _w	B _c -0.20 -0.008 -0.55 -0.022	Assembly Designation	C	C ₀	Speed Rating		C _g	S				Ht.
							Grease	Oil		Mounting Dimension				
										Max.	Min.	Max.	Min.	
mm in	mm in	mm in	mm in		kN lbf		min ⁻¹		mm in	mm in	mm in	mm in	kg lbs	
35 1.3780	35 1.3780	45 1.7717	41 1.614	K35X45X41	70.8 15920	113 25400	8400	13000	0.0515	35.000 1.3780	34.989 1.3775	45.025 1.7726	45.009 1.7720	0.120 0.265
	35 1.3780	45 1.7717	49 1.929	K35X45X49H	82.5 18550	138 31020	8400	13000	0.0541	35.000 1.3780	34.989 1.3775	45.025 1.7726	45.009 1.7720	0.143 0.315
	35 1.3780	45 1.7717	49 1.929	K35X45X49HZW	71.8 16140	115 25850	8400	13000	0.0518	35.000 1.3780	34.989 1.3775	45.025 1.7726	45.009 1.7720	0.143 0.315
	35 1.3780	50 1.9685	40 1.575	K35X50X40F	79.7 17920	102 22930	8700	13000	0.0480	35.000 1.3780	34.989 1.3775	50.025 1.9695	50.009 1.9689	0.200 0.441
36 1.4173	36 1.4173	40 1.5748	29 1.142	K36X40X29TN	21.2 4770	45.2 10160	7600	12000	—	36.000 1.4173	35.989 1.4169	40.025 1.5758	40.009 1.5752	0.029 0.064
	36 1.4173	42 1.6535	16 0.630	K36X42X16	22.8 5130	37.7 8480	7800	12000	0.0425	36.000 1.4173	35.989 1.4169	42.025 1.6545	42.009 1.6539	0.027 0.060
37 1.4567	37 1.4567	42 1.6535	13 0.512	K37X42X13H	16.9 3800	29.4 6610	7500	11000	0.0416	37.000 1.4567	36.989 1.4563	42.025 1.6545	42.009 1.6539	0.017 0.037
	37 1.4567	42 1.6535	17 0.669	K37X42X17H	21.9 4920	41.0 9220	7500	11000	0.0451	37.000 1.4567	36.989 1.4563	42.025 1.6545	42.009 1.6539	0.025 0.055
	37 1.4567	42 1.6535	27 1.063	K37X42X27F	32.1 7220	66.9 15040	7500	11000	0.0510	37.000 1.4567	36.989 1.4563	42.025 1.6545	42.009 1.6539	0.039 0.086
	37 1.4567	44 1.7323	19 0.748	K37X44X19H	29.7 6680	48.0 10790	7600	12000	0.0447	37.000 1.4567	36.989 1.4563	44.025 1.7333	44.009 1.7326	0.039 0.086
38 1.4961	38 1.4961	41 1.6142	9 0.354	K38X41X9TN	5.93 1330	11.0 2470	7100	11000	—	38.000 1.4961	37.989 1.4956	41.025 1.6152	41.009 1.6145	0.004 0.009
	38 1.4961	43 1.6929	17 0.669	K38X43X17H	21.8 4900	41.0 9220	7300	11000	0.0457	38.000 1.4961	37.989 1.4956	43.025 1.6939	43.009 1.6933	0.032 0.071
	38 1.4961	43 1.6929	27 1.063	K38X43X27	31.9 7170	67.0 15060	7300	11000	0.0516	38.000 1.4961	37.989 1.4956	43.025 1.6939	43.009 1.6933	0.041 0.090
	38 1.4961	46 1.8110	19.8 0.780	K38X46X20H	33.3 7490	51.0 11470	7500	12000	0.0450	38.000 1.4961	37.989 1.4956	46.025 1.8120	46.009 1.8114	0.055 0.121
	38 1.4961	46 1.8110	32 1.260	K38X46X32H	55.2 12410	98.1 22050	7500	12000	0.0530	38.000 1.4961	37.989 1.4956	46.025 1.8120	46.009 1.8114	0.090 0.198
	38 1.4961	50 1.9685	25 0.984	K38X50X25	53.0 11910	70.8 15920	7800	12000	0.0464	38.000 1.4961	37.989 1.4956	50.025 1.9695	50.009 1.9689	0.100 0.220
	38 1.4961	50 1.9685	33 1.299	K38X50X33H	68.3 15350	98.2 22080	7800	12000	0.0504	38.000 1.4961	37.989 1.4956	50.025 1.9695	50.009 1.9689	0.126 0.278

Shaft Dia.	F _w	E _w	B _c -0.20 -0.008 -0.55 -0.022	Assembly Designation	C	C ₀	Speed Rating		C _g	S				Ht.
							Grease	Oil		Mounting Dimension				
										Max.	Min.	Max.	Min.	
mm in	mm in	mm in	mm in		kN lbf		min ⁻¹		mm in	mm in	mm in	mm in	kg lbs	
38 1.4961	38 1.4961	50 1.9685	40 1.575	K38X50X40FH	76.2 17130	113 25400	7800	12000	0.0521	38.000 1.4961	37.989 1.4956	50.025 1.9695	50.009 1.9689	0.170 0.375
40 1.5748	40 1.5748	45 1.7717	13 0.512	K40X45X13H	17.6 3960	31.7 7130	6900	11000	0.0438	40.000 1.5748	39.989 1.5744	45.025 1.7726	45.009 1.7720	0.022 0.049
	40 1.5748	45 1.7717	18 0.709	K40X45X18H	25.1 5640	50.4 11330	6900	11000	0.0492	40.000 1.5748	39.989 1.5744	45.025 1.7726	45.009 1.7720	0.031 0.068
	40 1.5748	45 1.7717	21 0.827	K40X45X21H	23.3 5240	45.2 10160	6900	11000	0.0479	40.000 1.5748	39.989 1.5744	45.025 1.7726	45.009 1.7720	0.033 0.073
	40 1.5748	45 1.7717	27 1.063	K40X45X27H	32.7 7350	70.2 15780	6900	11000	0.0534	40.000 1.5748	39.989 1.5744	45.025 1.7726	45.009 1.7720	0.040 0.088
	40 1.5748	45 1.7717	27 1.063	K40X45X27TN	33.3 7490	72.1 16210	6900	11000	0.0538	40.000 1.5748	39.989 1.5744	45.025 1.7726	45.009 1.7720	0.030 0.066
	40 1.5748	45 1.7717	29 1.142	K40X45X29H	34.7 7800	75.9 17060	6900	11000	0.0545	40.000 1.5748	39.989 1.5744	45.025 1.7726	45.009 1.7720	0.050 0.110
	40 1.5748	46 1.8110	17 0.669	K40X46X17	25.2 5670	44.0 9890	7000	11000	0.0464	40.000 1.5748	39.989 1.5744	46.025 1.8120	46.009 1.8114	0.033 0.073
	40 1.5748	47 1.8504	18 0.709	K40X47X18	28.0 6290	45.6 10250	7000	11000	0.0456	40.000 1.5748	39.989 1.5744	47.025 1.8514	47.009 1.8507	0.041 0.090
	40 1.5748	47 1.8504	20 0.787	K40X47X20	31.1 6990	52.1 11710	7000	11000	0.0472	40.000 1.5748	39.989 1.5744	47.025 1.8514	47.009 1.8507	0.042 0.093
	40 1.5748	48 1.8898	20 0.787	K40X48X20FV1	35.5 7980	56.3 12660	7100	11000	0.0472	40.000 1.5748	39.989 1.5744	48.025 1.8907	48.009 1.8901	0.052 0.115
	40 1.5748	48 1.8898	20 0.787	K40X48X20H	35.5 7980	56.3 12660	7100	11000	0.0472	40.000 1.5748	39.989 1.5744	48.025 1.8907	48.009 1.8901	0.050 0.110
	40 1.5748	48 1.8898	35 1.378	K40X48X35H	57.3 12880	104 23380	7100	11000	0.0550	40.000 1.5748	39.989 1.5744	48.025 1.8907	48.009 1.8901	0.098 0.216
	40 1.5748	50 1.9685	27 1.063	K40X50X27H	53.0 11910	81.0 18210	7200	11000	0.0502	40.000 1.5748	39.989 1.5744	50.025 1.9695	50.009 1.9689	0.084 0.185
	40 1.5748	55 2.1654	45 1.772	K40X55X45H	103 23160	146 32820	7500	12000	0.0554	40.000 1.5748	39.989 1.5744	55.029 2.1665	55.010 2.1657	0.221 0.487
	40 1.5748	56 2.2047	26 1.024	K40X56X26H	63.7 14320	75.7 17020	7600	12000	0.0467	40.000 1.5748	39.989 1.5744	56.029 2.2059	56.010 2.2051	0.138 0.304
41 1.6142	41 1.6142	48 1.8898	31 1.220	K41X48X31HZW	38.0 8540	68.1 15310	6800	11000	0.0510	41.000 1.6142	40.989 1.6137	48.025 1.8907	48.009 1.8901	0.067 0.148
42 1.6535	42 1.6535	47 1.8504	13 0.512	K42X47X13H	18.7 4200	34.9 7850	6500	10000	0.0459	42.000 1.6535	41.989 1.6531	47.025 1.8514	47.009 1.8507	0.027 0.060
	42 1.6535	47 1.8504	17 0.669	K42X47X17H	22.8 5130	45.2 10160	6500	10000	0.0490	42.000 1.6535	41.989 1.6531	47.025 1.8514	47.009 1.8507	0.028 0.062
	42 1.6535	47 1.8504	27 1.063	K42X47X27H	33.8 7600	74.7 16790	6500	10000	0.0555	42.000 1.6535	41.989 1.6531	47.025 1.8514	47.009 1.8507	0.041 0.090
	42 1.6535	48 1.8898	24 0.945	K42X48X24F	33.1 7440	63.9 14370	6600	10000	0.0519	42.000 1.6535	41.989 1.6531	48.025 1.8907	48.009 1.8901	0.046 0.101
	42 1.6535	50 1.9685	13 0.512	K42X50X13H	20.9 4700	28.9 6500	6700	10000	0.0409	42.000 1.6535	41.989 1.6531	50.025 1.9695	50.009 1.9689	0.035 0.077
	42 1.6535	50 1.9685	20 0.787	K42X50X20H	35.2 7910	56.6 12720	6700	10000	0.0483	42.000 1.6535	41.989 1.6531	50.025 1.9695	50.009 1.9689	0.054 0.119
	42 1.6535	50 1.9685	30 1.181	K42X50X30H	51.3 11530	91.9 20660	6700	10000	0.0545	42.000 1.6535	41.989 1.6531	50.025 1.9695	50.009 1.9689	0.080 0.176

Continued on next page.



SINGLE-ROW,
DOUBLE-ROW
ASSEMBLIES –

continued

METRIC SERIES

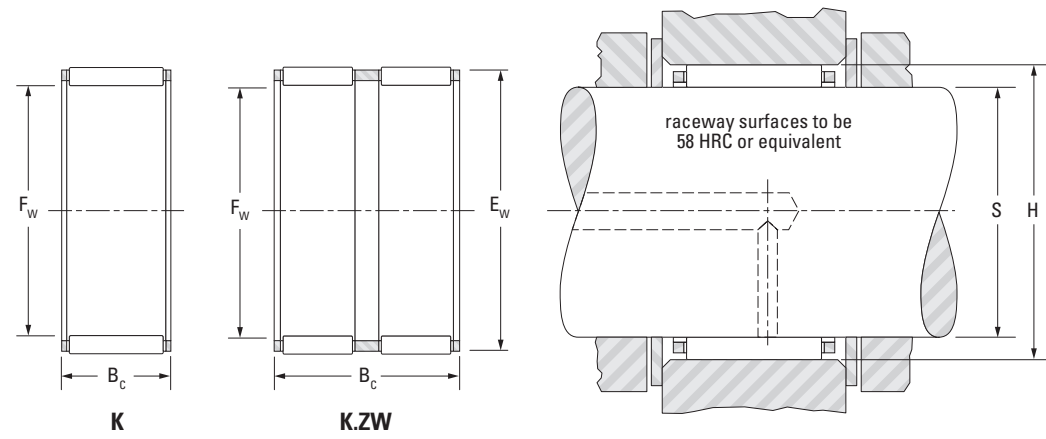

Shaft Dia.	F _w	E _w	B _c -0.20 -0.008 -0.55 -0.022	Assembly Designation	C		Speed Rating		C _g	S				Ht.
					Load Ratings		Grease	Oil		Mounting Dimension				
					kN lbf					min ⁻¹	Max.	Min.	Max.	
mm in	mm in	mm in	mm in		kN	lbf	min ⁻¹	mm in	mm in	mm in	mm in	kg lbs		
43 1.6929	43 1.6929	48 1.8898	17 0.669	K43X48X17FH	23.0 5170	45.8 10300	6400	9800	0.0496	43.000 1.6929	42.989 1.6925	48.025 1.8907	48.009 1.8901	0.036 0.079
	43 1.6929	48 1.8898	27 1.063	K43X48X27H	34.8 7820	78.0 17540	6400	9800	0.0567	43.000 1.6929	42.989 1.6925	48.025 1.8907	48.009 1.8901	0.050 0.110
44 1.7323	44 1.7323	50 1.9685	22 0.866	K44X50X22H	31.6 7100	60.6 13620	6400	9900	0.0523	44.000 1.7323	43.989 1.7319	50.025 1.9695	50.009 1.9689	0.046 0.101
	44 1.7323	50 1.9685	30 1.201	K44X50X30,5HZW	35.5 7980	70.5 15850	6400	9900	0.0543	44.000 1.7323	43.989 1.7319	50.025 1.9695	50.009 1.9689	0.068 0.150
45 1.7717	45 1.7717	50 1.9685	13 0.512	K45X50X13H	18.4 4140	35.1 7890	6100	9400	0.0474	45.000 1.7717	44.989 1.7712	50.025 1.9695	50.009 1.9689	0.022 0.049
	45 1.7717	50 1.9685	15 0.591	K45X50X15H	19.4 4360	37.3 8390	6100	9400	0.0482	45.000 1.7717	44.989 1.7712	50.025 1.9695	50.009 1.9689	0.028 0.062
	45 1.7717	50 1.9685	17 0.669	K45X50X17H	24.9 5600	51.8 11650	6100	9400	0.0523	45.000 1.7717	44.989 1.7712	50.025 1.9695	50.009 1.9689	0.030 0.066
	45 1.7717	50 1.9685	20 0.787	K45X50X20F	27.0 6070	57.4 12900	6100	9400	0.0536	45.000 1.7717	44.989 1.7712	50.025 1.9695	50.009 1.9689	0.040 0.088
	45 1.7717	50 1.9685	21 0.827	K45X50X21CH	24.6 5530	50.4 11330	6100	9400	0.0519	45.000 1.7717	44.989 1.7712	50.025 1.9695	50.009 1.9689	0.036 0.079
	45 1.7717	50 1.9685	27 1.063	K45X50X27FH	34.2 7690	77.4 17400	6100	9400	0.0577	45.000 1.7717	44.989 1.7712	50.025 1.9695	50.009 1.9689	0.043 0.095
	45 1.7717	50 1.9685	27 1.063	K45X50X27TN	31.8 7150	70.7 15890	6100	9400	—	45.000 1.7717	44.989 1.7712	50.025 1.9695	50.009 1.9689	0.048 0.106
	45 1.7717	52 2.0472	18 0.709	K45X52X18H	30.1 6770	52.0 11690	6200	9500	0.0497	45.000 1.7717	44.989 1.7712	52.029 2.0484	52.010 2.0476	0.045 0.099
	45 1.7717	52 2.0472	21 0.827	K45X52X21F	35.0 7870	63.2 14210	6200	9500	0.0521	45.000 1.7717	44.989 1.7712	52.029 2.0484	52.010 2.0476	0.055 0.121
	45 1.7717	53 2.0866	20 0.787	K45X53X20H	36.0 8090	59.5 13380	6200	9600	0.0504	45.000 1.7717	44.989 1.7712	53.029 2.0878	53.010 2.0870	0.054 0.119
	45 1.7717	53 2.0866	24.8 0.976	K45X53X25H	45.9 10320	81.5 18320	6200	9600	0.0545	45.000 1.7717	44.989 1.7712	53.029 2.0878	53.010 2.0870	0.072 0.159
	45 1.7717	53 2.0866	25 0.984	K45X53X25F	42.5 9550	73.7 16570	6200	9600	0.0531	45.000 1.7717	44.989 1.7712	53.029 2.0878	53.010 2.0870	0.075 0.165
	45 1.7717	53 2.0866	28 1.102	K45X53X28H	49.3 11080	89.2 20050	6200	9600	0.0557	45.000 1.7717	44.989 1.7712	53.029 2.0878	53.010 2.0870	0.078 0.172

Shaft Dia.	F _w	E _w	B _c -0.20 -0.008 -0.55 -0.022	Assembly Designation	C		Speed Rating		C _g	S				Ht.
					Load Ratings		Grease	Oil		Mounting Dimension				
					kN lbf					min ⁻¹	Max.	Min.	Max.	
mm in	mm in	mm in	mm in		kN	lbf	min ⁻¹	mm in	mm in	mm in	mm in	kg lbs		
45 1.7717	45 1.7717	55 2.1654	20 0.787	K45X55X20H	42.0 9440	62.2 13980	6400	9800	0.0494	45.000 1.7717	44.989 1.7712	55.029 2.1665	55.010 2.1657	0.074 0.163
	45 1.7717	59 2.3228	18 0.709	K45X59X18H	47.8 10750	58.9 13240	6600	10000	0.0467	45.000 1.7717	44.989 1.7712	59.029 2.3240	59.010 2.3232	0.107 0.236
	45 1.7717	59 2.3228	18 0.709	K45X59X18TN	45.7 10270	55.4 12450	6600	10000	—	45.000 1.7717	44.989 1.7712	59.029 2.3240	59.010 2.3232	0.097 0.214
	45 1.7717	59 2.3228	36 1.417	K45X59X36H	82.4 18520	118 26530	6600	10000	0.0555	45.000 1.7717	44.989 1.7712	59.029 2.3240	59.010 2.3232	0.181 0.399
	45 1.7717	60 2.3622	30 1.181	K45X60X30H	75.5 16970	101 22710	6600	10000	0.0530	45.000 1.7717	44.989 1.7712	60.029 2.3633	60.010 2.3626	0.171 0.377
	45 1.7717	60 2.3622	45 1.772	K45X60X45H	108 24280	160 35970	6600	10000	0.0594	45.000 1.7717	44.989 1.7712	60.029 2.3633	60.010 2.3626	0.280 0.617
46 1.8110	46 1.8110	53 2.0866	36 1.417	K46X53X36HZW	48.6 10930	96.7 21740	6100	9300	0.0585	46.000 1.8110	45.989 1.8106	53.029 2.0878	53.010 2.0870	0.100 0.220
47 1.8504	47 1.8504	52 2.0472	15 0.591	K47X52X15FH	20.1 4520	39.8 8950	5800	8900	0.0499	47.000 1.8504	46.989 1.8500	52.029 2.0484	52.010 2.0476	0.030 0.066
	47 1.8504	52 2.0472	17 0.669	K47X52X17H	24.2 5440	50.4 11330	5800	8900	0.0529	47.000 1.8504	46.989 1.8500	52.029 2.0484	52.010 2.0476	0.032 0.071
	47 1.8504	52 2.0472	27 1.063	K47X52X27H	36.6 8230	85.9 19310	5800	8900	0.0604	47.000 1.8504	46.989 1.8500	52.029 2.0484	52.010 2.0476	0.045 0.099
	47 1.8504	55 2.1654	28 1.102	K47X55X28FV1	48.9 10990	89.5 20120	6000	9200	0.0568	47.000 1.8504	46.989 1.8500	55.029 2.1665	55.010 2.1657	0.092 0.203
48 1.8898	48 1.8898	53 2.0866	17 0.669	K48X53X17H	25.7 5780	54.9 12340	5700	8700	0.0546	48.000 1.8898	47.989 1.8893	53.029 2.0878	53.010 2.0870	0.032 0.071
	48 1.8898	54 2.1260	19 0.748	K48X54X19H	30.9 6950	61.2 13760	5700	8800	0.0545	48.000 1.8898	47.989 1.8893	54.029 2.1271	54.010 2.1264	0.042 0.093
49 1.9291	49 1.9291	55 2.1654	32 1.260	K49X55X32HZW	40.2 9040	86.4 19420	5600	8600	0.0599	49.000 1.9291	48.989 1.9287	55.029 2.1665	55.010 2.1657	0.080 0.176
	49 1.9291	65 2.5591	38 1.496	K49X65X38H	100 22480	142 31920	6100	9300	0.0593	49.000 1.9291	48.989 1.9287	65.029 2.5602	65.010 2.5594	0.244 0.538
50 1.9685	50 1.9685	55 2.1654	17 0.669	K50X55X17H	25.5 5730	55.0 12360	5400	8400	0.0557	50.000 1.9685	49.989 1.9681	55.029 2.1665	55.010 2.1657	0.032 0.071
	50 1.9685	55 2.1654	20 0.787	K50X55X20H	30.2 6790	68.5 15400	5400	8400	0.0588	50.000 1.9685	49.989 1.9681	55.029 2.1665	55.010 2.1657	0.038 0.084
	50 1.9685	55 2.1654	30 1.181	K50X55X30	38.2 8590	92.4 20770	5400	8400	0.0633	50.000 1.9685	49.989 1.9681	55.029 2.1665	55.010 2.1657	0.057 0.120
	50 1.9685	55 2.1654	30 1.181	K50X55X30FV1	38.2 8590	92.4 20770	5400	8400	0.0633	50.000 1.9685	49.989 1.9681	55.029 2.1665	55.010 2.1657	0.057 0.126
	50 1.9685	56 2.2047	23 0.906	K50X56X23	35.5 7980	74.1 16660	5500	8500	0.0582	50.000 1.9685	49.989 1.9681	56.029 2.2059	56.010 2.2051	0.051 0.112
	50 1.9685	57 2.2441	18 0.709	K50X57X18FH	31.3 7040	56.4 12680	5500	8500	0.0531	50.000 1.9685	49.989 1.9681	57.029 2.2452	57.010 2.2445	0.050 0.110
	50 1.9685	58 2.2835	20 0.787	K50X58X20H	38.8 8720	67.8 15240	5600	8600	0.0545	50.000 1.9685	49.989 1.9681	58.029 2.2846	58.010 2.2839	0.065 0.143
	50 1.9685	58 2.2835	25 0.984	K50X58X25H	46.5 10450	85.6 19240	5600	8600	0.0577	50.000 1.9685	49.989 1.9681	58.029 2.2846	58.010 2.2839	0.081 0.179
	50 1.9685	58 2.2835	35 1.378	K50X58X35H	64.9 14590	131 29450	5600	8600	0.0642	50.000 1.9685	49.989 1.9681	58.029 2.2846	58.010 2.2839	0.105 0.231

Continued on next page.



SINGLE-ROW,
DOUBLE-ROW
ASSEMBLIES –

continued

METRIC SERIES

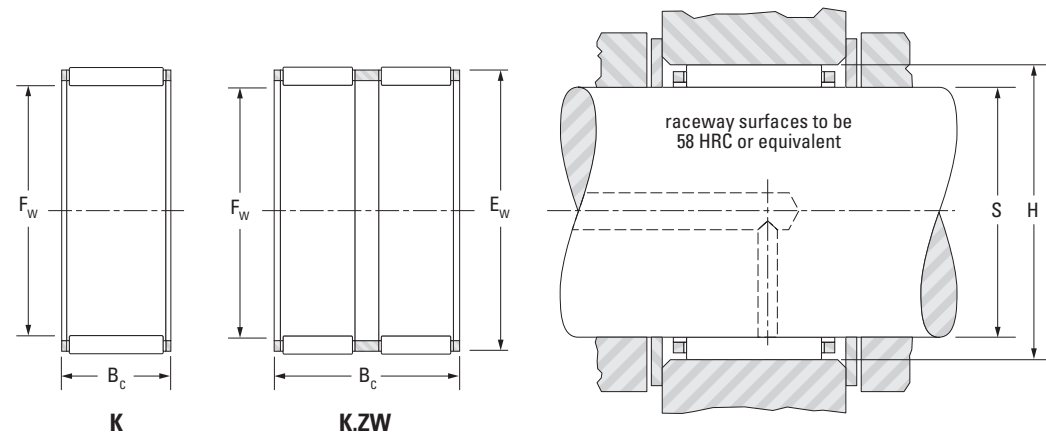

Shaft Dia.	F _w	E _w	B _c -0.20 -0.008 -0.55 -0.022	Assembly Designation	C		Speed Rating		C _g	S				H	Wt.
					Load Ratings		Grease	Oil		Mounting Dimension					
					kN lbf					min ⁻¹		Max.	Min.		
mm in	mm in	mm in	mm in		kN	lbf	min ⁻¹	min ⁻¹		mm in	mm in	mm in	mm in	kg lbs	
50 1.9685	50 1.9685	62 2.4409	30 1.181	K50X62X30H	64.6 14520	98.1 22050	5800	8900	0.0565	50.000 1.9685	49.989 1.9681	62.029 2.4421	62.010 2.4413	0.136 0.300	
	50 1.9685	66 2.5984	30 1.181	K50X66X30H	80.9 18190	109 24500	5900	9100	0.0559	50.000 1.9685	49.989 1.9681	66.029 2.5996	66.010 2.5988	0.192 0.423	
	50 1.9685	70 2.7559	32 1.260	K50X70X32H	103 23160	129 29000	6100	9300	0.0569	50.000 1.9685	49.989 1.9681	70.029 2.7570	70.010 2.7563	0.224 0.494	
52 2.0472	52 2.0472	57 2.2441	12 0.472	K52X57X12	18.4 4140	36.7 8250	5200	8000	0.0512	52.000 2.0472	51.987 2.0467	57.029 2.2452	57.010 2.2445	0.022 0.049	
	52 2.0472	57 2.2441	17 0.669	K52X57X17H	21.4 4810	44.3 9960	5200	8000	0.0537	52.000 2.0472	51.987 2.0467	57.029 2.2452	57.010 2.2445	0.035 0.077	
	52 2.0472	60 2.3622	24 0.945	K52X60X24	47.1 10600	88.3 19900	5400	8200	0.0592	52.000 2.0472	51.987 2.0467	60.029 2.3633	60.010 2.3626	0.078 0.172	
55 2.1654	55 2.1654	60 2.3622	17 0.669	K55X60X17	26.0 5850	58.3 13100	4900	7600	0.0590	55.000 2.1654	54.987 2.1648	60.029 2.3633	60.010 2.3626	0.037 0.082	
	55 2.1654	60 2.3622	20 0.787	K55X60X20H	30.7 6900	72.4 16300	4900	7600	0.0622	55.000 2.1654	54.987 2.1648	60.029 2.3633	60.010 2.3626	0.042 0.093	
	55 2.1654	60 2.3622	27 1.063	K55X60X27H	40.1 9010	102 22900	4900	7600	0.0677	55.000 2.1654	54.987 2.1648	60.029 2.3633	60.010 2.3626	0.055 0.121	
	55 2.1654	60 2.3622	30 1.181	K55X60X30FH	40.6 9130	103 23200	4900	7600	0.0680	55.000 2.1654	54.987 2.1648	60.029 2.3633	60.010 2.3626	0.068 0.150	
	55 2.1654	61 2.4016	26 1.024	K55X61X26H	44.3 9960	102 22900	5000	7600	0.0657	55.000 2.1654	54.987 2.1648	61.029 2.4027	61.010 2.4020	0.063 0.139	
	55 2.1654	62 2.4409	18 0.709	K55X62X18H	33.2 7460	62.8 14100	5000	7700	0.0569	55.000 2.1654	54.987 2.1648	62.029 2.4421	62.010 2.4413	0.055 0.121	
	55 2.1654	63 2.4803	15 0.591	K55X63X15F	30.5 6860	51.5 11600	5000	7800	0.0531	55.000 2.1654	54.987 2.1648	63.029 2.4815	63.010 2.4807	0.054 0.119	
	55 2.1654	63 2.4803	20 0.787	K55X63X20	40.3 9060	73.5 16500	5000	7800	0.0580	55.000 2.1654	54.987 2.1648	63.029 2.4815	63.010 2.4807	0.072 0.159	
	55 2.1654	63 2.4803	25 0.984	K55X63X25	49.8 11200	96.5 21700	5000	7800	0.0621	55.000 2.1654	54.987 2.1648	63.029 2.4815	63.010 2.4807	0.080 0.176	
	55 2.1654	63 2.4803	32 1.260	K55X63X32	62.3 14000	129 29000	5000	7800	0.0667	55.000 2.1654	54.987 2.1648	63.029 2.4815	63.010 2.4807	0.108 0.238	
58 2.2835	58 2.2835	63 2.4803	17 0.669	K58X63X17F	27.0 6070	62.6 14100	4700	7200	0.0615	58.000 2.2835	57.987 2.2830	63.029 2.4815	63.010 2.4807	0.037 0.082	

Shaft Dia.	F _w	E _w	B _c -0.20 -0.008 -0.55 -0.022	Assembly Designation	C		Speed Rating		C _g	S				H	Wt.
					Load Ratings		Grease	Oil		Mounting Dimension					
					kN lbf					min ⁻¹		Max.	Min.		
mm in	mm in	mm in	mm in		kN	lbf	min ⁻¹	min ⁻¹		mm in	mm in	mm in	mm in	kg lbs	
58 2.2835	58 2.2835	64 2.5197	19 0.748	K58X64X19H	32.9 7400	70.6 15900	4700	7200	0.0615	58.000 2.2835	57.987 2.2830	64.029 2.5208	64.010 2.5201	0.037 0.082	
	58 2.2835	65 2.5591	18 0.709	K58X65X18H	34.3 7710	67.1 15100	4700	7300	0.0593	58.000 2.2835	57.987 2.2830	65.029 2.5602	65.010 2.5594	0.058 0.128	
60 2.3622	60 2.3622	65 2.5591	20 0.787	K60X65X20H	31.9 7170	78.1 17600	4500	6900	0.0660	60.000 2.3622	59.987 2.3617	65.029 2.5602	65.010 2.5594	0.046 0.101	
	60 2.3622	65 2.5591	26.8 1.055	K60X65X27FH	39.5 8880	103 23200	4500	6900	0.0707	60.000 2.3622	59.987 2.3617	65.029 2.5602	65.010 2.5594	0.059 0.130	
	60 2.3622	65 2.5591	29.8 1.173	K60X65X30FH	42.9 9640	114 25600	4500	6900	0.0726	60.000 2.3622	59.987 2.3617	65.029 2.5602	65.010 2.5594	0.085 0.187	
	60 2.3622	65 2.5591	30 1.181	K60X65X30	42.9 9640	114 25600	4500	6900	0.0726	60.000 2.3622	59.987 2.3617	65.029 2.5602	65.010 2.5594	0.070 0.154	
	60 2.3622	68 2.6772	17 0.669	K60X68X17F	34.2 7690	61.4 13800	4600	7100	0.0577	60.000 2.3622	59.987 2.3617	68.029 2.6783	68.010 2.6776	0.066 0.146	
	60 2.3622	68 2.6772	20 0.787	K60X68X20H	41.8 9400	79.2 17800	4600	7100	0.0614	60.000 2.3622	59.987 2.3617	68.029 2.6783	68.010 2.6776	0.066 0.146	
	60 2.3622	68 2.6772	23 0.906	K60X68X23H	49.0 11000	97.2 21900	4600	7100	0.0646	60.000 2.3622	59.987 2.3617	68.029 2.6783	68.010 2.6776	0.089 0.196	
	60 2.3622	68 2.6772	25 0.984	K60X68X25	51.6 11600	104 23400	4600	7100	0.0657	60.000 2.3622	59.987 2.3617	68.029 2.6783	68.010 2.6776	0.091 0.201	
	60 2.3622	68 2.6772	30 1.181	K60X68X30ZW	46.4 10400	90.1 20300	4600	7100	0.0634	60.000 2.3622	59.987 2.3617	68.029 2.6783	68.010 2.6776	0.119 0.262	
63 2.4803	63 2.4803	71 2.7953	20 0.787	K63X71X20	41.4 9310	79.4 17800	4400	6700	0.0628	63.000 2.4803	62.987 2.4798	71.029 2.7964	71.010 2.7957	0.070 0.154	
64 2.5197	64 2.5197	70 2.7559	16 0.630	K64X70X16	26.4 5930	55.1 12400	4200	6500	0.0605	64.000 2.5197	63.987 2.5192	70.029 2.7570	70.010 2.7563	0.049 0.108	
65 2.5591	65 2.5591	70 2.7559	20 0.787	K65X70X20CH	28.6 6430	69.2 15600	4100	6400	0.0665	65.000 2.5591	64.987 2.5585	70.029 2.7570	70.010 2.7563	0.050 0.110	
	65 2.5591	70 2.7559	30 1.181	K65X70X30	44.4 9980	123 27700	4100	6400	0.0766	65.000 2.5591	64.987 2.5585	70.029 2.7570	70.010 2.7563	0.075 0.165	
	65 2.5591	73 2.8740	23 0.906	K65X73X23H	48.2 10800	97.7 22000	4200	6500	0.0671	65.000 2.5591	64.987 2.5585	73.029 2.8752	73.010 2.8744	0.091 0.201	
	65 2.5591	73 2.8740	30 1.181	K65X73X30H	60.1 13500	129 29100	4200	6500	0.0719	65.000 2.5591	64.987 2.5585	73.029 2.8752	73.010 2.8744	0.116 0.256	
68 2.6772	68 2.6772	74 2.9134	20 0.787	K68X74X20FH	37.5 8430	88.1 19800	4000	6100	0.0699	68.000 2.6772	67.987 2.6767	74.029 2.9145	74.010 2.9138	0.062 0.137	
	68 2.6772	74 2.9134	28 1.102	K68X74X28CH	44.8 10100	110 24700	4000	6100	0.0739	68.000 2.6772	67.987 2.6767	74.029 2.9145	74.010 2.9138	0.082 0.181	
	68 2.6772	74 2.9134	30 1.181	K68X74X30H	47.6 10700	119 26800	4000	6100	0.0754	68.000 2.6772	67.987 2.6767	74.029 2.9145	74.010 2.9138	0.098 0.216	
	68 2.6772	74 2.9134	35 1.378	K68X74X35HZW	45.1 10100	111 25000	4000	6100	0.0740	68.000 2.6772	67.987 2.6767	74.029 2.9145	74.010 2.9138	0.120 0.265	
	68 2.6772	76 2.9921	20 0.787	K68X76X20	43.8 9850	87.8 19700	4000	6200	0.0667	68.000 2.6772	67.987 2.6767	76.029 2.9933	76.010 2.9925	0.086 0.190	
70 2.7559	70 2.7559	76 2.9921	20 0.787	K70X76X20	36.1 8120	84.7 19000	3900	5900	0.0702	70.000 2.7559	69.987 2.7554	76.029 2.9933	76.010 2.9925	0.065 0.143	
	70 2.7559	76 2.9921	30 1.181	K70X76X30	51.6 11600	134.0 30100	3900	5900	0.0786	70.000 2.7559	69.987 2.7554	76.029 2.9933	76.010 2.9925	0.097 0.214	

Continued on next page.



**SINGLE-ROW,
DOUBLE-ROW
ASSEMBLIES –**

continued

METRIC SERIES

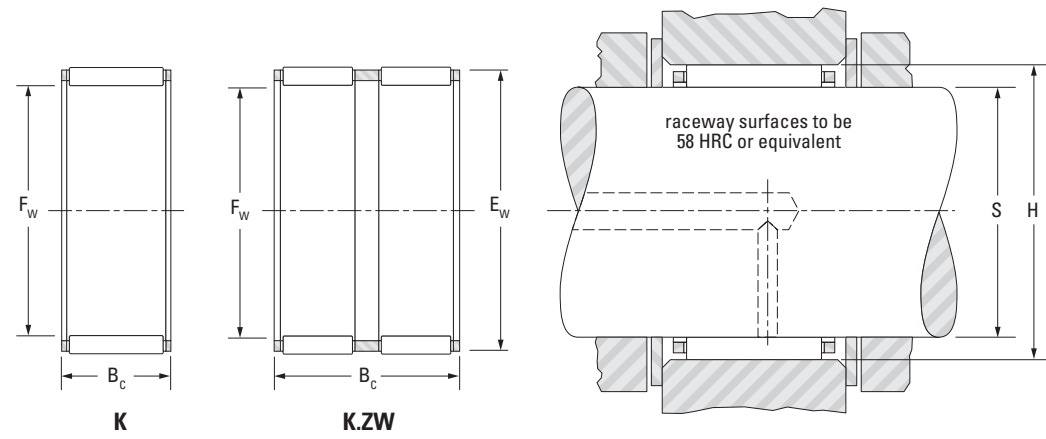

Shaft Dia.	F _w	E _w	B _c -0.20 -0.008 -0.55 -0.022	Assembly Designation	C	C ₀	Speed Rating		C _g	S				H	Wt.
							Grease	Oil		Mounting Dimension					
										Max.	Min.	Max.	Min.		
mm in	mm in	mm in	mm in		kN lbf		min ⁻¹		mm in	mm in	mm in	mm in	kg lbs		
70 2.7559	70 2.7559	78 3.0709	20 0.787	K70X78X20H	43.6 9800	87.9 19800	3900	6000	0.0676	70.000 2.7559	69.987 2.7554	78.029 3.0720	78.010 3.0713	0.090 0.198	
	70 2.7559	78 3.0709	23 0.906	K70X78X23F	49.8 11200	104.0 23400	3900	6000	0.0705	70.000 2.7559	69.987 2.7554	78.029 3.0720	78.010 3.0713	0.115 0.254	
	70 2.7559	78 3.0709	24.8 0.976	K70X78X25F	49.8 11200	104.0 23400	3900	6000	0.0705	70.000 2.7559	69.987 2.7554	78.029 3.0720	78.010 3.0713	0.115 0.254	
	70 2.7559	78 3.0709	30 1.181	K70X78X30H	62.2 14000	139.0 31200	3900	6000	0.0757	70.000 2.7559	69.987 2.7554	78.029 3.0720	78.010 3.0713	0.140 0.309	
	70 2.7559	78 3.0709	46 1.811	K70X78X46ZW	78.4 17600	187.0 42000	3900	6000	0.0815	70.000 2.7559	69.987 2.7554	78.029 3.0720	78.010 3.0713	0.188 0.414	
	70 2.7559	85 3.3465	40 1.575	K70X85X40F	118 26500	203 45600	4100	6300	0.0758	70.000 2.7559	69.987 2.7554	85.034 3.3478	85.012 3.3469	0.338 0.745	
	70 2.7559	88 3.4646	30 1.181	K70X88X30H	115 25900	175 39300	4100	6400	0.0714	70.000 2.7559	69.987 2.7554	88.034 3.4659	88.012 3.4650	0.205 0.452	
72 2.8346	72 2.8346	80 3.1496	20 0.787	K72X80X20	44.4 9980	90.7 20400	3800	5800	0.0690	72.000 2.8346	71.987 2.8341	80.029 3.1507	80.010 3.1500	0.084 0.185	
73 2.8740	73 2.8740	79 3.1102	20 0.787	K73X79X20	37.0 8320	88.7 19900	3700	5700	0.0723	73.000 2.8740	72.987 2.8735	79.029 3.1114	79.010 3.1106	0.068 0.150	
75 2.9528	75 2.9528	81 3.1890	20 0.787	K75X81X20F	37.4 8410	90.7 20400	3600	5500	0.0737	75.000 2.9528	74.987 2.9522	81.034 3.1903	81.012 3.1894	0.075 0.165	
	75 2.9528	83 3.2677	23 0.906	K75X83X23	52.5 11800	114.0 25600	3600	5600	0.0744	75.000 2.9528	74.987 2.9522	83.034 3.2691	83.012 3.2682	0.104 0.229	
	75 2.9528	83 3.2677	30 1.181	K75X83X30	60.9 13700	138 31000	3600	5600	0.0780	75.000 2.9528	74.987 2.9522	83.034 3.2691	83.012 3.2682	0.141 0.311	
	75 2.9528	83 3.2677	30 1.181	K75X83X30FH	60.9 13700	138 31000	3600	5600	0.0780	75.000 2.9528	74.987 2.9522	83.034 3.2691	83.012 3.2682	0.141 0.311	
80 3.1496	80 3.1496	86 3.3858	20 0.787	K80X86X20H	38.6 8680	96.7 21700	3400	5200	0.0771	80.000 3.1496	79.987 3.1491	86.034 3.3872	86.012 3.3863	0.072 0.159	
	80 3.1496	88 3.4646	25 0.984	K80X88X25FV1	54.0 12100	121 27200	3400	5200	0.0778	80.000 3.1496	79.987 3.1491	88.034 3.4659	88.012 3.4650	0.134 0.295	
	80 3.1496	88 3.4646	30 1.181	K80X88X30	67.5 15200	161 36200	3400	5200	0.0835	80.000 3.1496	79.987 3.1491	88.034 3.4659	88.012 3.4650	0.153 0.337	
85 3.3465	85 3.3465	92 3.6220	20 0.787	K85X92X20H	39.9 8970	91.7 20600	3200	4900	0.0763	84.988 3.3460	84.973 3.3454	92.034 3.6234	92.012 3.6225	0.085 0.187	

Shaft Dia.	F _w	E _w	B _c -0.20 -0.008 -0.55 -0.022	Assembly Designation	C	C ₀	Speed Rating		C _g	S				H	Wt.
							Grease	Oil		Mounting Dimension					
										Max.	Min.	Max.	Min.		
mm in	mm in	mm in	mm in		kN lbf		min ⁻¹		mm in	mm in	mm in	mm in	kg lbs		
85 3.3465	85 3.3465	93 3.6614	25 0.984	K85X93X25F	58.8 13219	138 31024	3200	4900	—	84.988 3.3460	84.973 3.3454	93.034 3.6628	93.012 3.6619	0.000 0.000	
	85 3.3465	93 3.6614	30 1.181	K85X93X30H	31024* 15600	3200 38200	4900	4900	0.0870	84.988 3.3460	84.973 3.3454	93.034 3.6628	93.012 3.6619	0.166 0.366	
90 3.5433	90 3.5433	97 3.8189	20 0.787	K90X97X20	46.3 10400	114 25600	3000	4600	0.0827	89.988 3.5428	89.973 3.5422	97.034 3.8202	97.012 3.8194	0.095 0.209	
	90 3.5433	98 3.8583	25 0.984	K90X98X25F	54.8 12300	128 28800	3000	4600	0.0832	89.988 3.5428	89.973 3.5422	98.034 3.8596	98.012 3.8587	0.134 0.295	
	90 3.5433	98 3.8583	30 1.181	K90X98X30	63.6 14300	155 34800	3000	4600	0.0873	89.988 3.5428	89.973 3.5422	98.034 3.8596	98.012 3.8587	0.168 0.370	
95 3.7402	95 3.7402	103 4.0551	20 0.787	K95X103X20	49.3 11100	114 25600	2800	4400	0.0829	94.988 3.7397	94.973 3.7391	103.034 4.0565	103.012 4.0556	0.130 0.287	
	95 3.7402	103 4.0551	30 1.181	K95X103X30F	71.0 16000	183 41100	2800	4400	0.0932	94.988 3.7397	94.973 3.7391	103.034 4.0565	103.012 4.0556	0.180 0.39	
100 3.9370	100 3.9370	108 4.2520	30 1.181	K100X108X30	72.4 16300	191 42900	2700	4200	0.0965	99.988 3.9365	99.973 3.9359	108.034 4.2533	108.012 4.2524	0.210 0.463	
110 4.3307	110 4.3307	118 4.6457	24 0.945	K110X118X24	64.0 14400	168 37800	2400	3800	0.0977	109.988 4.3302	109.973 4.3296	118.034 4.6470	118.012 4.6461	0.165 0.364	
	110 4.3307	118 4.6457	30 1.181	K110X118X30H	75.3 16900	207 46500	2400	3800	0.1029	109.988 4.3302	109.973 4.3296	118.034 4.6470	118.012 4.6461	0.200 0.441	



RADIAL NEEDLE ROLLER AND CAGE ASSEMBLIES FOR CONNECTING ROD APPLICATIONS

METRIC SERIES

Connecting rods have two bearing positions: the crank pin or big end, and the wrist pin or small end.

In the crank pin position there may be severe operating conditions due to centrifugal forces, internal forces, accelerations and high rotational speeds, requiring the use of special radial needle roller and cage assemblies.

Similarly, in the wrist pin position the reciprocating inertia loads and high oscillating speeds dictate the use of special cage designs.

Needle roller and cage assembly for crank pin applications

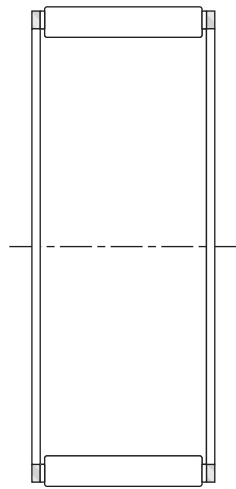

K.BE

Needle roller and cage assembly for wrist pin applications

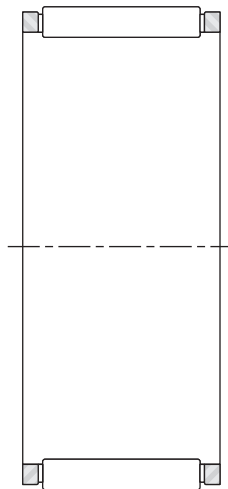

K.SE

Fig. B-3. Types of metric series radial needle roller and cage assemblies

Suffixes

BE	steel cage, heat treated, for crank pin position
SE	steel cage, heat treated, for wrist pin position

CONSTRUCTION

METRIC SERIES RADIAL NEEDLE ROLLER AND CAGE ASSEMBLIES FOR CRANK PIN POSITIONS

Needle roller and cage assemblies for use in crank pin positions have cages with a large outside cylindrical surface to ensure optimum radial guidance in the connecting rod bore. Due to the inherent low weight and strength of the heat-treated cages, the needle roller and cage assemblies are well-suited for high-speed engine applications. When necessary, silver plating and copper plating can be applied for optimum performance during operation at high speeds.

METRIC SERIES RADIAL NEEDLE ROLLER AND CAGE ASSEMBLIES FOR WRIST PIN POSITIONS

Reciprocating inertia loads and oscillating speeds require the cages used in the wrist pin positions to be heat-treated and to guide on the wrist pin.

These cages are available in a variety of widths to allow the selection of a needle roller and cage assembly with the length of needle rollers to match the connecting rod width.

SIZE SELECTION

In most instances, selection of a suitable size of a needle roller and cage assembly for typical connecting rod positions may be based on the cylinder displacement of the engine which in turn, dictates the crank pin and wrist pin diameters.

Suggestions, based on engine displacements, are listed in the following table.

Table B-3. Crank pin and wrist pin diameters, determined by the cylinder displacement of the engine

		Cylinder displacement in cm ³						
Cylinder	>	40	60	100	150	200	300	
Displacement	≤	40	60	100	150	200	300	
		Diameter						
		mm in	mm in	mm in	mm in	mm in	mm in	
Crank pin		12/14 0.4724/0.5512	15/16/18 0.5906/0.6299/0.7087	18/20 0.7087/0.7874	18/20/22 0.7087/0.7874/0.8661	24/25/28 0.9449/0.9843/1.1024	28/30 1.1024/1.1811	35/40 1.3780/1.5748
Wrist pin		10/11 0.3937/0.4331	12/13 0.4724/0.5118	14/15 0.5512/0.5906	15/16 0.5906/0.6299	18 0.7087	20 0.7874	20 0.7874



CONNECTING ROD GUIDANCE ARRANGEMENTS

End guidance of a connecting rod can be provided either at the crank pin or at the wrist pin end. Connecting-rod guidance is achieved at the crank pin end using a small clearance between the crank counterweights. Guidance at the wrist pin end is controlled by a small clearance between the piston bosses.

CRANK PIN END GUIDANCE

With crank pin end guidance, care must be taken that an adequate amount of lubricant is supplied to the crank pin bearing and the surfaces that guide the connecting rod. For this purpose, grooves in the connecting rod end faces, or slots in the connecting rod bore aligned with the incoming lubrication path, should be provided. Occasionally, bronze or hardened steel washers may be used for end guidance of the connecting rod.

At the wrist pin end, the needle roller and cage assembly is located axially between the piston bosses. It may be both economical and effective to machine the connecting rod at the wrist pin end and at the crank pin end to the same width. It is suggested that, at the wrist

pin end, the needle roller length does not overhang the connecting rod width. Otherwise, the load rating of the needle roller and cage assembly will be reduced.

WRIST PIN END GUIDANCE

Wrist pin end will get the most effective axial guidance between the piston bosses. Grooves in the bottom of the piston bosses and a chamfer of small angle – on each side of the upper portion of the connecting rod small end – can improve the oil flow to the needle roller and cage assembly and its guiding surfaces.

The length of the needle roller and cage assembly and the connecting rod width at the crank pin end should be identical to ensure best possible radial piloting of cage in the bore of the connecting rod. The crank counterweights are recessed to allow proper axial alignment of the connecting rod. As a rule, it is not necessary to have an additional supply of lubricant. Only in engines with sparse lubrication should consideration be given to provide lubricating slots in the connecting rod bores as with crank pin end guidance.

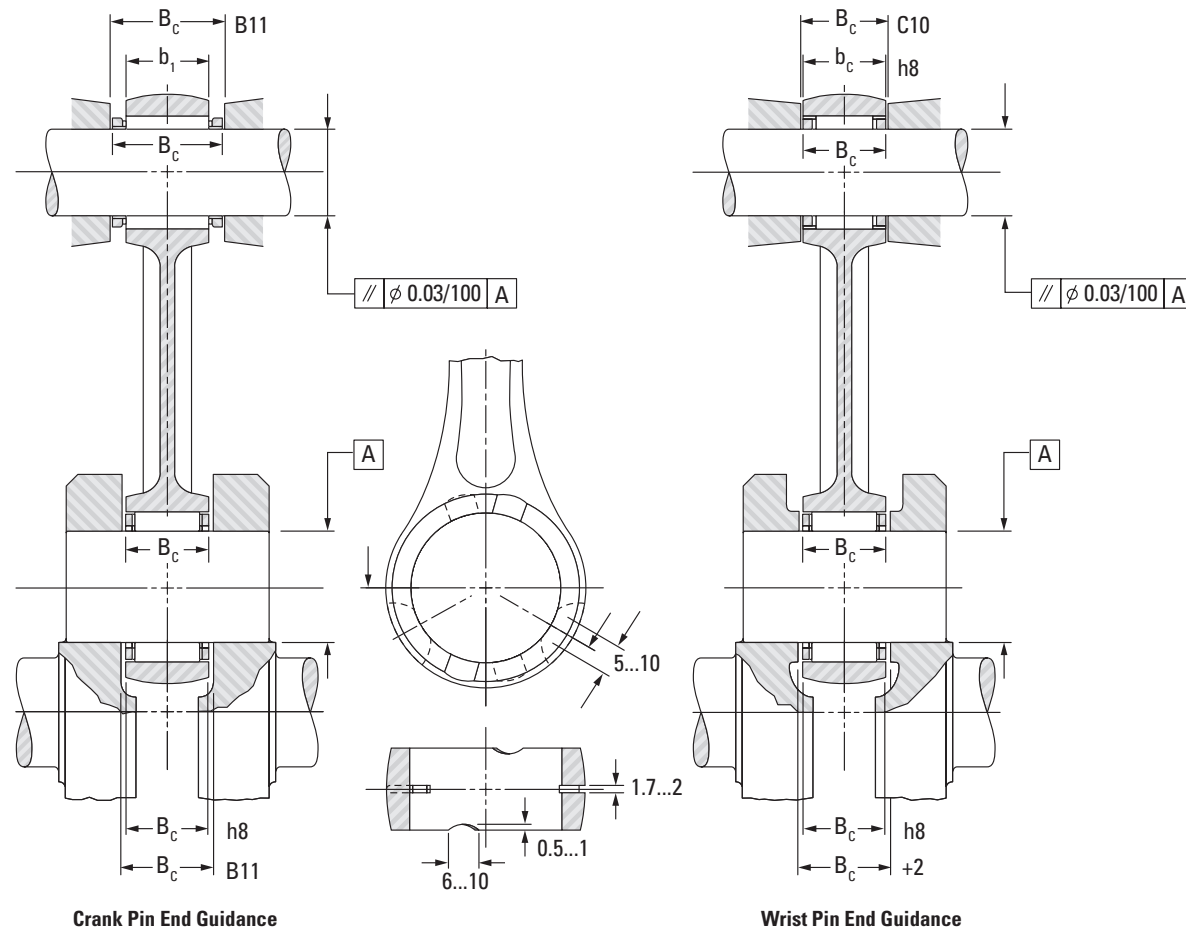

Fig. B-4. Crank pin and wrist pin end guidance

SUITABLE MATERIALS AND HEAT TREATMENT

Connecting rod crank pin end and wrist pin end bores serve as raceways:

a case-hardening steel such as 15 CrNi 6, 17 MnCr 5 or AISI 8620.

Crank pins:

e.g., case-hardening steel 15 Cr 3, AISI 8620, AISI 1018 or through-hardening steel 100 Cr 6, AISI 52100.

Wrist pins:

e.g., case-hardening steel Ck 15, 15 Cr 3 or through-hardening steel 100 Cr 6, AISI 52100.

The effective case depth (50 HRC) of the raceways should be 0.5 mm (0.0197 in) minimum, and the surface hardness should be 60 HRC or 700 HV minimum.

After hardening, the connecting rods must be stress-relieved.

The connecting rod raceway bores, as well as the crank pins and the wrist pins, must be precision-ground or preferably honed to a surface finish Ra not exceeding 0.16 μm.

FORM TOLERANCES

The form tolerances for crank pins, wrist pins and connecting rod bores are listed in Table B-4.

Table B-4. Form tolerances

		Dimension in mm				
Nominal pin diameter	>	10	14	18	25	30
	≤	14	18	25	30	40
		Tolerances in μm				
Parallelism ⁽¹⁾	wrist pin & crank pin	1	1	2	2	3
	rod bore	2	3	3	4	4
Circularity (DIN ISO 1101)	wrist pin & crank pin	1	1	1.5	1.5	2
	rod bore	1.5	2	2	2.5	2.5

⁽¹⁾ The parallelism values are valid for the needle roller length L_W.

It is suggested that the parallelism of the wrist pin axis and the crank pin axis be within a tolerance zone of 0.03 mm (0.0012 in) diameter over a distance of 100 mm (3.9370 in).

RADIAL CLEARANCE

METRIC SERIES CRANK PIN BEARINGS

The high speeds of modern production engines dictate the need for crank pin bearings with a relatively large radial clearance. As an approximation, the minimum clearance can be taken as the crank pin diameter/1000. The maximum radial clearance would be a result of the sorting plan shown in Table B-5(1) on page B-30.

As shown in the example of the matching scheme, the suggested mounting diameters for the crank pin position are G6 for the connecting rod bore diameters and h5 for the crank pin diameters. Axial location of the cage is shown on the crank pin end guidance arrangement.

Racing and sport engines operate at even higher speeds than production engines, requiring 50 percent larger radial clearances in the crank pin bearings. The larger radial clearances also should be used in bores of split connecting rods to avoid the danger of distortion – resulting from the unavoidable connecting rod deformation occurring in operation. Consult your representative for advice on such applications.

METRIC SERIES WRIST PIN BEARINGS

The radial clearance in wrist pin bearings should be held as small as possible. The minimum clearance should be aimed at 2 μm with the maximum clearance resulting from the proposed sorting plan in Table B-5(2) on page B-30. The maximum clearance should be held as close as possible to 12 μm for all wrist pin bearings based on sorting wrist pins made to a tolerance h5, small end bore diameter tolerance of K6 and needle roller grades as shown in Table B-5(2) on page B-30.



METRIC SERIES RADIAL NEEDLE ROLLER AND CAGE ASSEMBLIES FOR CONNECTING ROD APPLICATIONS

MATCHING SCHEME FOR A CRANK PIN BEARING ARRANGEMENT
(three diameter ranges are specified for the connecting rod and crank pin)

Example: Satisfy conditions of Radial clearance 20 μm – 33 μm
 Crank pin diameter 20 mm, tolerance h5
 Connecting rod bore diameter 26 mm, tolerance G6
 Needle roller and cage assembly K20x26x12BE

Table B-5(1). Radial clearance

	Connecting Rod Crank Pin End Bore Diameter 26 mm Tolerance range						
	+7 – +12		+12 – +16		+16 – +20		
	Needle Roller Tolerance	Radial Clearance	Needle Roller Tolerance	Radial Clearance	Needle Roller Tolerance	Radial Clearance	
Crank Pin Diameter 20 mm Tolerance range	-3 – 0	-9 – -7	21 – 33	-6 – -4 -7 – -5	20 – 31 22 – 33	-4 – -2 -5 – -3	20 – 31 22 – 33
	-6 – -3	-7 – -5	20 – 32	-5 – -3	21 – 32	-3 – -1	21 – 32
	-9 – -6	-6 – -4	21 – 33	-3 – -1 -4 – -2	20 – 31 22 – 33	-2 – 0	22 – 33

MATCHING SCHEME FOR A WRIST PIN BEARING ARRANGEMENT
(three diameter ranges are specified for the connecting rod and wrist pin)

Example: Satisfy conditions of Radial clearance 2 μm – 16 μm
 Wrist pin diameter 16 mm, tolerance h5
 Connecting rod bore diameter 20 mm, tolerance K6
 Needle roller and cage assembly K16x20x20SE

Table B-5(2). Radial clearance

	Wrist Pin End Bore Diameter 20 mm Tolerance range						
	-11 – -6		-6 – -2		-2 – +2		
	Needle Roller Tolerance	Radial Clearance	Needle Roller Tolerance	Radial Clearance	Needle Roller Tolerance	Radial Clearance	
Wrist Pin Diameter 16 mm Tolerance range	-3 – 0		-6 – -4 -7 – -5	2 – 13 4 – 15	-4 – -2 -5 – -3	2 – 13 4 – 15	
	-6 – -3	-7 – -5	2 – 14	-5 – -3 -6 – -4	3 – 14 5 – 16	-3 – -1 -4 – -2	3 – 14 5 – 16
	-8 – -6	-6 – -4 -7 – -5	3 – 14 5 – 16	-3 – -1 -4 – -2	2 – 12 4 – 14	-2 – 0	4 – 10

ASSEMBLIES FOR CRANK PIN END APPLICATIONS

METRIC SERIES

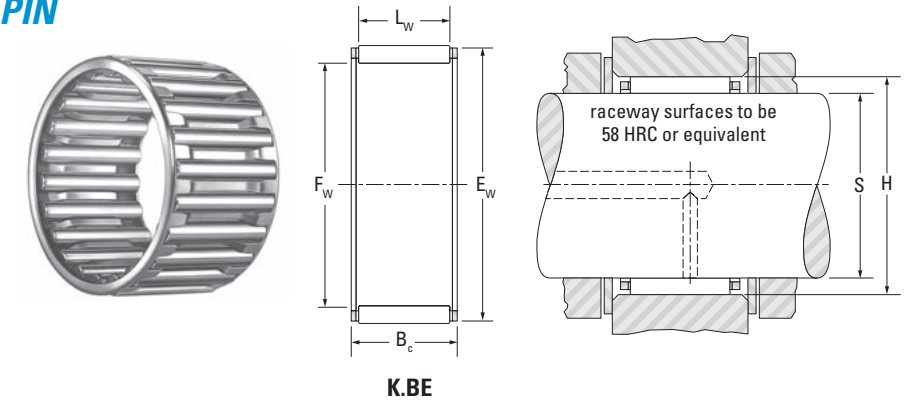

Shaft Dia.	F _w	E _w	B _c		L _w	Assembly Designation	C		C ₀	C _g	Mounting Dimensions (non-high performance engines)				Wt.
			Load Ratings				S	H							
			Max.	Min.				Max.			Min.				
mm in	mm in	mm in	-0.2 -0.008 -0.55 -0.022	mm in	mm in	kN lbf		mm in	mm in	mm in	mm in	kg lbs			
12 0.4724	12 0.4724	16 0.6299	10 0.394	7.8 0.307	K12X16X10BE	6.21 1400	6.70 1510	—	12.000 0.4724	11.992 0.4721	16.017 0.6306	16.006 0.6302	0.004 0.009		
	12 0.4724	17 0.6693	10 0.394	7.8 0.307	K12X17X10BE	7.32 1650	7.21 1620	—	12.000 0.4724	11.992 0.4721	17.017 0.6700	17.006 0.6695	0.005 0.011		
14 0.5512	14 0.5512	18 0.7087	10 0.394	7.8 0.307	K14X18X10BE	6.89 1550	7.98 1790	—	14.000 0.5512	13.992 0.5509	18.017 0.7093	18.006 0.7089	0.005 0.011		
	14 0.5512	20 0.7874	10 0.394	7.8 0.307	K14X20X10BE	8.90 2000	8.61 1940	0.0198	14.000 0.5512	13.992 0.5509	20.020 0.7882	20.007 0.7877	0.007 0.015		
	14 0.5512	20 0.7874	12 0.472	9.5 0.374	K14X20X12BE	10.50 2360	10.60 2380	0.0209	14.000 0.5512	13.992 0.5509	20.020 0.7882	20.007 0.7877	0.009 0.020		
16 0.6299	16 0.6299	21 0.8268	10 0.394	7.8 0.307	K16X21X10BE	8.17 1840	8.90 2000	0.0215	16.000 0.6299	15.992 0.6296	21.020 0.8276	21.007 0.8270	0.007 0.015		
	16 0.6299	22 0.8661	12 0.472	9.5 0.374	K16X22X12BE	11.20 2520	11.90 2680	0.0227	16.000 0.6299	15.992 0.6296	22.020 0.8669	22.007 0.8664	0.011 0.024		
18 0.7087	18 0.7087	24 0.9449	12 0.472	9.5 0.374	K18X24X12BE	11.80 2650	13.10 2940	0.0243	18.000 0.7087	17.992 0.7083	24.020 0.9457	24.007 0.9452	0.011 0.024		
	18 0.7087	24 0.9449	13 0.512	10.5 0.413	WK18X24X13BE	12.80 2880	14.60 3280	0.0250	18.000 0.7087	17.992 0.7083	24.020 0.9457	24.007 0.9452	0.011 0.024		
	18 0.7087	24 0.9449	15 0.591	11.8 0.465	K18X24X15BE	13.30 2990	15.20 3420	0.0253	18.000 0.7087	17.992 0.7083	24.020 0.9457	24.007 0.9452	0.014 0.031		
19 0.7480	19 0.7480	25 0.9843	15 0.591	12.5 0.492	K19X25X15BE	14.70 3300	17.60 3960	0.0268	19.000 0.7480	18.991 0.7477	25.020 0.9850	25.007 0.9845	0.014 0.031		
20 0.7874	20 0.7874	26 1.0236	12 0.472	9.8 0.386	K20X26X12BE	13.30 2990	15.80 3550	0.0267	20.000 0.7874	19.991 0.7870	26.020 1.0244	26.007 1.0239	0.013 0.029		
	20 0.7874	26 1.0236	17 0.669	13.8 0.543	K20X26X17BE	14.90 3350	18.20 4090	0.0276	20.000 0.7874	19.991 0.7870	26.020 1.0244	26.007 1.0239	0.017 0.037		
22 0.8661	22 0.8661	28 1.1024	13 0.512	9.8 0.386	K22X28X13BE	13.90 3120	17.10 3840	0.0283	22.000 0.8661	21.991 0.8658	28.020 1.1031	28.007 1.1026	0.015 0.033		
	22 0.8661	29 1.1417	16 0.630	12.8 0.504	K22X29X16BE	18.50 4160	22.30 5010	0.0296	22.000 0.8661	21.991 0.8658	29.020 1.1425	29.007 1.1420	0.021 0.046		
24 0.9449	24 0.9449	30 1.1811	13 0.512	9.8 0.386	K24X30X13BE	14.40 3240	18.40 4140	0.0298	24.000 0.9449	23.991 0.9445	30.020 1.1819	30.007 1.1814	0.016 0.035		
	24 0.9449	30 1.1811	15 0.591	11.8 0.465	K24X30X15BE	15.30 3440	19.70 4430	0.0304	24.000 0.9449	23.991 0.9445	30.020 1.1819	30.007 1.1814	0.018 0.040		

Continued on next page.



ASSEMBLIES FOR CRANK PIN
END APPLICATIONS –

continued

METRIC SERIES

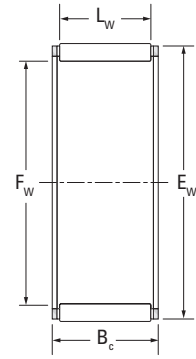

K.BE

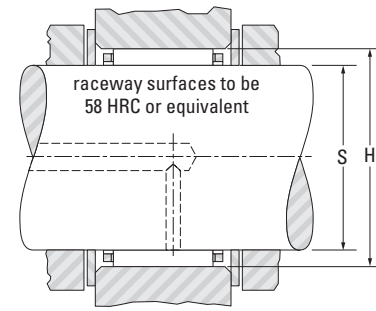

Shaft Dia.	F _w	E _w	B _c	L _w	Assembly Designation	C		C _g	S		H		Wt.
						Load Ratings			Mounting Dimensions (non-high performance engines)				
						Max.	Min.		Max.	Min.	Max.	Min.	
24 0.9449	24 0.9449	30 1.1811	-0.2 -0.008 -0.55 -0.022 17 0.669	13.8 0.543	K24X30X17BE	19.00 4270	26.30 5910	0.0326	24.000 0.9449	23.991 0.9445	30.020 1.1819	30.007 1.1814	0.021 0.040
25 0.9843	25 0.9843	31 1.2205	19.8 0.780	17.8 0.701	WK25X31X20BE	23.30 5240	34.50 7760	0.0355	25.000 0.9843	24.991 0.9839	31.025 1.2215	31.009 1.2208	0.024 0.053
	25 0.9843	32 1.2598	16 0.630	12.8 0.504	K25X32X16BE	19.20 4320	24.30 5460	0.0319	25.000 0.9843	24.991 0.9839	32.025 1.2608	32.009 1.2602	0.022 0.049
	25 0.9843	32 1.2598	24 0.945	19.8 0.780	K25X32X24BE	27.50 6180	38.50 8660	0.0358	25.000 0.9843	24.991 0.9839	32.025 1.2608	32.009 1.2602	0.035 0.077
30 1.1811	30 1.1811	37 1.4567	16 0.630	12.8 0.504	K30X37X16BE	21.60 4860	29.80 6700	0.0363	30.000 1.1811	29.991 1.1807	37.025 1.4577	37.009 1.4570	0.029 0.064
35 1.3780	35 1.3780	42 1.6535	20 0.787	16.8 0.661	K35X42X20BE	29.70 6680	47.00 10600	0.0434	35.000 1.3780	34.989 1.3775	42.025 1.6545	42.009 1.6539	0.039 0.086

ASSEMBLIES FOR WRIST PIN
END APPLICATIONS

METRIC SERIES

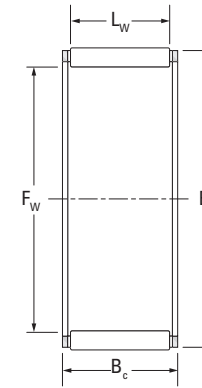

K.SE

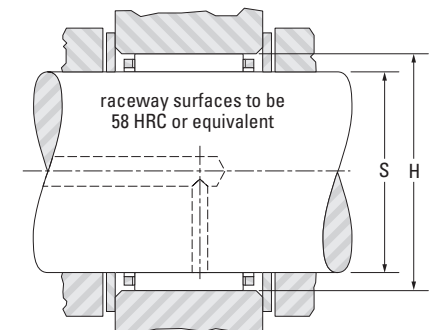

Shaft Dia.	F _w	E _w	B _c	L _w	Assembly Designation	C		C _g	S		H		Wt.
						Load Ratings			Mounting Dimensions (non-high performance engines)				
						Max.	Min.		Max.	Min.	Max.	Min.	
9 0.3543	9 0.3543	12 0.4724	-0.20 -0.008 -0.55 -0.022 11.5 0.453	8.4 0.331	K9X12X11,5SE	4.23 951	4.53 1020	0.0296	9.000 0.3543	8.994 0.3541	12.017 0.4731	12.006 0.4727	0.003 0.007
	9 0.3543	13 0.5118	12.5 0.492	9.8 0.386	K9X13X12,5SE	5.58 1250	5.41 1220	0.0306	9.000 0.3543	8.994 0.3541	13.017 0.5125	13.006 0.5120	0.005 0.011
10 0.3937	10 0.3937	13 0.5118	14.5 0.571	11.8 0.465	K10X13X14,5SE	5.93 1330	7.20 1620	0.0152	10.000 0.3937	9.994 0.3935	13.017 0.5125	13.006 0.5120	0.004 0.009
	10 0.3937	14 0.5512	10.0 0.394	7.0 0.276	K10X14X10SE	4.62 1040	4.36 980	0.0155	10.000 0.3937	9.994 0.3935	14.017 0.5519	14.006 0.5514	0.004 0.009
12 0.4724	12 0.4724	15 0.5906	13.0 0.512	9.8 0.386	K12X15X13SE	6.00 1350	7.72 1740	0.0179	12.000 0.4724	11.992 0.4721	15.017 0.5912	15.006 0.5908	0.004 0.009
	12 0.4724	15 0.5906	15.0 0.591	11.8 0.465	K12X15X15SE	6.97 1570	9.36 2100	0.0153	12.000 0.4724	11.992 0.4721	15.017 0.5912	15.006 0.5908	0.005 0.011
	12 0.4724	15 0.5906	17.5 0.689	12.8 0.504	K12X15X17,5SE	7.45 1670	10.2 2290	0.0196	12.000 0.4724	11.992 0.4721	15.017 0.5912	15.006 0.5908	0.006 0.013
	12 0.4724	16 0.6299	13.0 0.512	9.8 0.386	K12X16X13SE	6.03 1360	6.38 1430	0.0206	12.000 0.4724	11.992 0.4721	16.017 0.6306	16.006 0.6302	0.006 0.013
	12 0.4724	17 0.6693	13.0 0.512	9.8 0.386	K12X17X13SE	7.61 1710	7.54 1700	0.0210	12.000 0.4724	11.992 0.4721	17.017 0.6700	17.006 0.6695	0.007 0.015
	12 0.4724	17 0.6693	15.0 0.591	12.5 0.492	K12X17X15SE	9.30 2090	9.75 2190	0.0181	12.000 0.4724	11.992 0.4721	17.017 0.6700	17.006 0.6695	0.007 0.015
13 0.5118	13 0.5118	16 0.6299	14.0 0.551	9.8 0.386	K13X16X14SE	5.62 1260	7.23 1630	0.0184	13.000 0.5118	12.992 0.5115	16.017 0.6306	16.006 0.6302	0.005 0.011
	13 0.5118	17 0.6693	17.7 0.697	13.8 0.543	K13X17X17,7SE	9.80 2200	12.3 2770	0.0196	13.000 0.5118	12.992 0.5115	17.017 0.6700	17.006 0.6695	0.008 0.018
	13 0.5118	18 0.7087	15.0 0.591	12.5 0.492	K13X18X15SE	9.28 2090	9.88 2220	0.0200	13.000 0.5118	12.992 0.5115	18.017 0.7093	18.006 0.7089	0.008 0.018
14 0.5512	14 0.5512	18 0.7087	13.0 0.512	9.8 0.386	K14X18X13SE	7.39 1660	8.69 1950	0.0220	14.000 0.5512	13.992 0.5509	18.017 0.7093	18.006 0.7089	0.007 0.015
	14 0.5512	18 0.7087	17.0 0.669	11.8 0.465	K14X18X17SE	8.59 1930	10.5 2360	0.0203	14.000 0.5512	13.992 0.5509	18.017 0.7093	18.006 0.7089	0.009 0.020
	14 0.5512	18 0.7087	21.0 0.827	14.8 0.583	K14X18X21SE	10.3 2320	13.3 2990	0.0208	14.000 0.5512	13.992 0.5509	18.017 0.7093	18.006 0.7089	0.011 0.024
15 0.5906	15 0.5906	19 0.7480	17.0 0.669	11.8 0.465	K15X19X17SE	9.05 2030	11.5 2590	0.0218	15.000 0.5906	14.992 0.5902	19.020 0.7488	19.007 0.7483	0.009 0.020

Continued on next page.



ASSEMBLIES FOR WRIST PIN
END APPLICATIONS – continued

METRIC SERIES

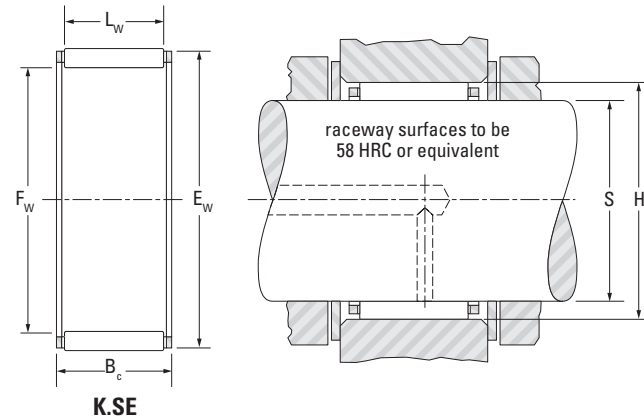

Shaft Dia.	F _w	E _w	B _c		L _w	Assembly Designation	C		C ₀	C _g	Mounting Dimensions (non-high performance engines)				Wt.
			Load Ratings				S				H				
			mm	in			mm	in			Max.	Min.	Max.	Min.	
15 0.5906	15 0.5906	19 0.7480	19.5 0.768	15.8 0.622	K15X19X19,5SE	10.8 2430	14.3 3210	0.0231	15.000 0.5906	14.992 0.5902	19.020 0.7488	19.007 0.7483	0.010 0.022		
	15 0.5906	19 0.7480	20.0 0.787	15.8 0.622	K15X19X20SE	10.8 2430	14.3 3210	0.0229	15.000 0.5906	14.992 0.5902	19.020 0.7488	19.007 0.7483	0.010 0.022		
16 0.6299	16 0.6299	20 0.7874	20.0 0.787	15.8 0.622	K16X20X20SE	12.0 2700	16.9 3800	0.0242	16.000 0.6299	15.992 0.6296	20.020 0.7882	20.007 0.7877	0.011 0.024		
	16 0.6299	20 0.7874	22.0 0.866	15.8 0.622	K16X20X22SE	12.0 2700	16.9 3800	0.0242	16.000 0.6299	15.992 0.6296	20.020 0.7882	20.007 0.7877	0.013 0.029		
	16 0.6299	20 0.7874	23.0 0.906	15.8 0.622	K16X20X23SE	10.7 2410	14.5 3260	0.0259	16.000 0.6299	15.992 0.6296	20.020 0.7882	20.007 0.7877	0.013 0.029		
18 0.7087	18 0.7087	22 0.8661	22.0 0.866	17.8 0.701	K18X22X22SE	14.4 3240	22.0 4950	0.0259	18.000 0.7087	17.992 0.7083	22.020 0.8669	22.007 0.8664	0.016 0.035		
	18 0.7087	23 0.9055	20.0 0.787	15.8 0.622	K18X23X20SE	13.6 3060	17.6 3960	0.0249	18.000 0.7087	17.992 0.7083	23.020 0.9063	23.007 0.9058	0.015 0.033		
	18 0.7087	23 0.9055	23.0 0.906	17.8 0.701	K18X23X23SE	15.9 3570	21.6 4860	0.0291	18.000 0.7087	17.992 0.7083	23.020 0.9063	23.007 0.9058	0.018 0.040		
19 0.7480	19 0.7480	24 0.9449	25.5 1.004	17.8 0.701	K19X24X25,5SE	16.7 3750	23.4 5260	0.0268	19.000 0.7480	18.991 0.7477	24.020 0.9457	24.007 0.9452	0.022 0.049		
20 0.7874	20 0.7874	24 0.9449	23.0 0.906	17.8 0.701	K20X24X23SE	14.8 3330	23.7 5330	0.0282	20.000 0.7874	19.991 0.7870	24.020 0.9457	24.007 0.9452	0.017 0.037		
	20 0.7874	25 0.9843	22.0 0.866	16.8 0.661	K20X25X22SE	15.9 3570	22.2 4990	0.0294	20.000 0.7874	19.991 0.7870	25.020 0.9850	25.007 0.9845	0.020 0.044		
	20 0.7874	25 0.9843	23.0 0.906	17.8 0.701	K20X25X23SE	17.5 3930	25.2 5670	0.0310	20.000 0.7874	19.991 0.7870	25.020 0.9850	25.007 0.9845	0.025 0.055		

RADIAL NEEDLE ROLLER AND CAGE ASSEMBLIES

INCH SERIES

Inch series radial needle roller and cage assemblies are available in a variety of sizes and designs. This catalog includes the most popular, standardized designs.

REFERENCE STANDARDS:

- ANSI/ABMA 18.2 – needle roller bearings – radial, inch design.

Before selecting specific inch series radial needle roller and cage assemblies, the engineering section should be reviewed.

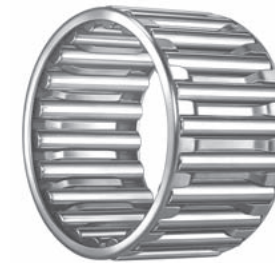

WJ

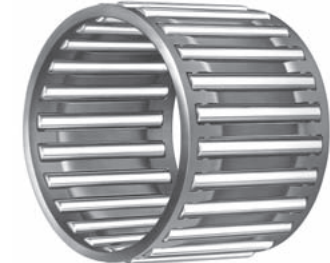

WJC

Fig. B-5. Types of inch series radial needle roller and cage assemblies

There are two primary constructions of inch series needle roller and cage assemblies. WJ assemblies are heavy-duty compared to WJC assemblies due to the nature of the roller diameter.

CONSTRUCTION

Radial needle roller and cage assemblies have a steel cage that provides both inward and outward retention for the needle rollers. The designs provide maximum cage strength consistent with the inherent high load-ratings of needle roller bearings.

Accurate guidance of the needle rollers by the cage bars allows for operation at high speeds. Needle roller and cage assemblies have either one or two rows of needle rollers.

Also available (by request) are needle roller and cage assemblies using molded, one-piece glass-reinforced engineered polymer cages. These operate well at temperatures up to 250° F (120° C) over extended periods. However, care should be exercised when bearings are lubricated with oils containing additives, as service life may be reduced if the operating temperature exceeds 212° F (100° C). At such high temperatures, oil can deteriorate with time and it is suggested that oil change intervals are observed.

Needle rollers with relieved ends – used in these assemblies are made of high carbon chrome steel through-hardened, ground and lapped to close tolerances for diameter and roundness. See the engineering section for further discussion of relieved end rollers.

DIMENSIONAL ACCURACY

The nominal inch assemblies, WJ and WJC, contain needle rollers manufactured to only one diameter grade. Within any one assembly, the needle rollers have a total diameter tolerance of 0.0001 in (0.003 mm).

The limit to precision of the radial clearance of mounted needle roller and cage assemblies is the capability of the user to hold close tolerances on the inner and outer raceways.

The tolerance of the overall width of these assemblies is given in the bearing tables of this section.

MOUNTING DIMENSIONS

The needle roller and cage assembly normally uses the shaft and housing as the inner and outer raceways. To realize full bearing load rating and life, the shaft and housing must have the correct geometric and metallurgical characteristics.

The tables of dimensions for these assemblies list the suggested diameters for the shaft when used as the inner raceway. These are consistent with ISO h5 shaft raceway tolerances. Additional design details for shafts used as inner raceways can be found in the engineering section.

Since the housing normally serves as the outer raceway, it should be of sufficient cross section to maintain adequate roundness and running clearance under load. The tables of dimensions



also list the suggested diameters for the housings when used as outer raceways. These are consistent with ISO G6 housing bore tolerances. Additional design details for housings used as outer raceways can be found in the engineering section.

The suggested mounting diameter tolerances for these needle roller and cage assemblies will provide correct running clearance for most applications.

The needle roller and cage assembly must be axially located by shoulders or other suitable means. End locating surfaces should be hardened to minimize wear. For satisfactory operation, minimum axial clearance should be 0.008 in (0.203 mm). When using type WJ assembly, fillets adjacent to the assembly must not exceed 0.03 in (0.762 mm) radius. When it is necessary to use fillets adjacent to WJC assembly, please consult your representative for suggestions.

LUBRICATION

Oil is the preferred lubricant for most applications. In critical applications involving high speeds, ample oil flow must be provided. Where assemblies are subjected to high centrifugal forces, such as in epicyclic gearing, or inertia forces, as in the small end of a connecting rod, the contact pressure between the cage and the raceway guiding surface becomes critical. The allowable contact pressure depends on a combination of the induced force and the relative velocity between the cage and the raceway and the rate of lubricant flow. Consult your representative when cages will be subjected to high induced forces.

SPECIAL DESIGNS

Needle roller and cage assemblies made to special dimensions or configurations, such as those that are split to assemble around a one-piece crankshaft, can be made available on special order where quantities permit. Special plated cages to enhance life under conditions of high induced forces can also be made available.

SINGLE-ROW ASSEMBLIES

INCH SERIES

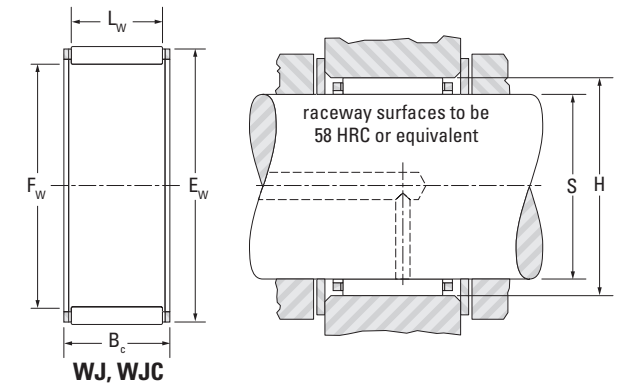

Shaft Dia.	F _w	E _w	B _c +0 +0 -0.38 -0.015	Assembly Designation	C	C ₀	Grease	Oil	C _g	S (ISO h5)		H (ISO G6)		Wt.
										Mounting Dimensions				
										Max.	Min.	Max.	Min.	
in	mm in	mm in	mm in		kN lbf			min ⁻¹		mm in	mm in	mm in	mm in	kg lbs
3/8	9.525 0.3750	12.700 0.5000	9.53 0.375	WJC-060806	3.87 870	4.00 900	24000	37000	0.0170	9.525 0.3750	9.520 0.3748	12.715 0.5006	12.705 0.5002	0.003 0.006
1/2	12.700 0.5000	15.875 0.6250	12.70 0.500	WJC-081008	6.23 1400	8.01 1800	23000	35000	0.0227	12.700 0.5000	12.692 0.4997	15.890 0.6256	15.880 0.6252	0.005 0.010
9/16	14.288 0.5625	17.463 0.6875	12.70 0.500	WJC-091108	6.81 1530	9.25 2080	22000	34000	0.0247	14.288 0.5625	14.280 0.5622	17.478 0.6881	17.468 0.6877	0.006 0.013
5/8	15.875 0.6250	19.050 0.7500	12.70 0.500	WJC-101208	7.03 1580	9.96 2240	18000	27000	0.0264	15.875 0.6250	15.867 0.6247	19.070 0.7508	19.058 0.7503	0.006 0.013
	15.875 0.6250	22.225 0.8750	15.88 0.625	WJ-101410	15.6 3510	17.8 3990	19000	29000	0.0280	15.875 0.6250	15.867 0.6247	22.245 0.8758	22.233 0.8753	0.012 0.027
	15.875 0.6250	22.225 0.8750	22.23 0.875	WJ-101414	21.3 4780	26.4 5940	19000	29000	0.0309	15.875 0.6250	15.867 0.6247	22.245 0.8758	22.233 0.8753	0.017 0.038
3/4	19.050 0.7500	25.400 1.0000	25.40 1.000	WJ-121616	26.8 6020	37.2 8370	16000	24000	0.0362	19.050 0.7500	19.040 0.7496	25.420 1.0008	25.408 1.0003	0.023 0.051
13/16	20.638 0.8125	26.988 1.0625	22.23 0.875	WJ-131714	25.1 5650	35.0 7880	14000	22000	0.0368	20.638 0.8125	20.627 0.8121	27.008 1.0633	26.995 1.0628	0.021 0.046
7/8	22.225 0.8750	28.575 1.1250	25.40 1.000	WJ-141816	29.2 6570	43.5 9770	13000	20000	0.0401	22.225 0.8750	22.215 0.8746	28.595 1.1258	28.583 1.1253	0.026 0.058
1	25.400 1.0000	33.338 1.3125	19.05 0.750	WJ-162112	28.1 6320	37.1 8340	12000	18000	0.0397	25.400 1.0000	25.390 0.9996	33.363 1.3135	33.348 1.3129	0.029 0.063
	25.400 1.0000	33.338 1.3125	25.40 1.000	WJ-162116	36.8 8270	52.5 11800	12000	18000	0.0432	25.400 1.0000	25.390 0.9996	33.363 1.3135	33.348 1.3129	0.038 0.084
	25.400 1.0000	33.338 1.3125	31.75 1.250	WJ-162120	44.5 10000	67.2 15100	12000	18000	0.0460	25.400 1.0000	25.390 0.9996	33.363 1.3135	33.348 1.3129	0.048 0.105
1 1/8	28.575 1.1250	38.100 1.5000	25.40 1.000	WJ-182416	42.4 9520	57.8 13000	10000	16000	0.0455	28.575 1.1250	28.565 1.1246	38.125 1.5010	38.110 1.5004	0.041 0.090
	28.575 1.1250	38.100 1.5000	31.75 1.250	WJ-182420	52 11700	74.7 16800	10000	16000	0.0485	28.575 1.1250	28.565 1.1246	38.125 1.5010	38.110 1.5004	0.065 0.143
1 1/4	31.750 1.2500	41.275 1.6250	19.05 0.750	WJ-202612	33.4 7520	43.7 9830	9300	14000	0.0443	31.750 1.2500	31.740 1.2496	41.300 1.6260	41.285 1.6254	0.043 0.094
	31.750 1.2500	41.275 1.6250	25.40 1.000	WJ-202616	44.1 9910	62.3 14000	9300	14000	0.0484	31.750 1.2500	31.740 1.2496	41.300 1.6260	41.285 1.6254	0.061 0.134
	31.750 1.2500	41.275 1.6250	31.75 1.250	WJ-202620	53.8 12100	81.0 18200	9300	14000	0.0517	31.750 1.2500	31.740 1.2496	41.300 1.6260	41.285 1.6254	0.071 0.156

Load ratings are based on a minimum raceway hardness of 58 HRC or equivalent.

Minimum axial clearance should be 0.02 mm (0.008 in).

Continued on next page.



Shaft Dia.	F _w	E _w	B _c +0 -0.38 -0.015	Assembly Designation	C	C ₀	Grease	Oil	C _g	S (ISO h5)		H (ISO G6)		Wt.
										Mounting Dimensions				
										Max.	Min.	Max.	Min.	
in	mm in	mm in	mm in		kN lbf		min ⁻¹			mm in	mm in	mm in	mm in	kg lbs
1¼	31.750 1.2500	41.275 1.6250	38.10 1.500	WJ-202624	63.6 14300	99.6 22400	9300	14000	0.0544	31.750 1.2500	31.740 1.2496	41.300 1.6260	41.285 1.6254	0.085 0.188
1⅝	34.925 1.3750	44.450 1.7500	25.40 1.000	WJ-222816	45.8 10300	67.2 15100	8300	13000	0.0513	34.925 1.3750	34.915 1.3746	44.475 1.7510	44.460 1.7504	0.067 0.147
	34.925 1.3750	44.450 1.7500	31.75 1.250	WJ-222820	56.0 12600	87.2 19600	8300	13000	0.0547	34.925 1.3750	34.915 1.3746	44.475 1.7510	44.460 1.7504	0.077 0.170
1½	38.100 1.5000	47.625 1.8750	25.40 1.000	WJ-243016	47.2 10600	71.6 16100	7600	12000	0.0541	38.100 1.5000	38.090 1.4996	47.650 1.8760	47.635 1.8754	0.078 0.172
	38.100 1.5000	47.625 1.8750	31.75 1.250	WJ-243020	57.8 13000	93.0 20900	7600	12000	0.0577	38.100 1.5000	38.090 1.4996	47.650 1.8760	47.635 1.8754	0.083 0.184
	38.100 1.5000	47.625 1.8750	38.10 1.500	WJ-243024	68.1 15300	114.8 25800	7600	12000	0.0608	38.100 1.5000	38.090 1.4996	47.650 1.8760	47.635 1.8754	0.100 0.220
	38.100 1.5000	47.625 1.8750	44.45 1.750	WJ-243028	77.4 17400	135.7 30500	7600	12000	0.0634	38.100 1.5000	38.090 1.4996	47.650 1.8760	47.635 1.8754	0.134 0.295
1¾	44.450 1.7500	53.975 2.1250	19.05 0.750	WJ-283412	39.5 8870	59.6 13400	6400	9900	0.0552	44.450 1.7500	44.440 1.7496	54.003 2.1261	53.985 2.1254	0.058 0.127
	44.450 1.7500	53.975 2.1250	25.40 1.000	WJ-283416	52.0 11700	85.0 19100	6400	9900	0.0603	44.450 1.7500	44.440 1.7496	54.003 2.1261	53.985 2.1254	0.084 0.185
	44.450 1.7500	53.975 2.1250	38.10 1.500	WJ-283424	74.7 16800	136 30600	6400	9900	0.0677	44.450 1.7500	44.440 1.7496	54.003 2.1261	53.985 2.1254	0.115 0.253
2	50.800 2.0000	60.325 2.3750	19.05 0.750	WJ-323812	42.8 9610	69 15500	5600	8600	0.0606	50.800 2.0000	50.787 1.9995	60.353 2.3761	60.335 2.3754	0.065 0.143
	50.800 2.0000	60.325 2.3750	25.40 1.000	WJ-323816	56.5 12700	98 22100	5600	8600	0.0662	50.800 2.0000	50.787 1.9995	60.353 2.3761	60.335 2.3754	0.105 0.231
	50.800 2.0000	60.325 2.3750	31.75 1.250	WJ-323820	69.0 15500	127 28700	5600	8600	0.0707	50.800 2.0000	50.787 1.9995	60.353 2.3761	60.335 2.3754	0.108 0.238
	50.800 2.0000	60.325 2.3750	38.10 1.500	WJ-323824	81.0 18200	157 35300	5600	8600	0.0744	50.800 2.0000	50.787 1.9995	60.353 2.3761	60.335 2.3754	0.130 0.286
2⅛	52.388 2.0625	61.913 2.4375	25.40 1.000	WJ-333916	57.8 13000	102 23100	5400	8300	0.0678	52.388 2.0625	52.375 2.0620	61.940 2.4386	61.923 2.4379	0.099 0.218
2⅞	53.975 2.1250	63.500 2.5000	25.40 1.000	WJ-344016	52.5 11800	92.08 20700	5200	8000	0.0668	53.975 2.1250	53.962 2.1245	63.528 2.5011	63.510 2.5004	0.089 0.196
	53.975 2.1250	63.500 2.5000	38.10 1.500	WJ-344024	78.3 17600	153 34500	5200	8000	0.0759	53.975 2.1250	53.962 2.1245	63.528 2.5011	63.510 2.5004	0.137 0.302
2⅜	55.563 2.1875	65.088 2.5625	19.05 0.750	WJ-354112	44.5 10000	75.17 16900	5000	7800	0.0644	55.563 2.1875	55.550 2.1870	65.115 2.5636	65.098 2.5629	0.070 0.155
	55.563 2.1875	65.088 2.5625	25.40 1.000	WJ-354116	57.8 13000	107 24100	5000	7800	0.0704	55.563 2.1875	55.550 2.1870	65.115 2.5636	65.098 2.5629	0.094 0.207
2¼	57.150 2.2500	66.675 2.6250	25.40 1.000	WJ-364216	53.8 12100	96.08 21600	4900	7500	0.0693	57.150 2.2500	57.137 2.2495	66.703 2.6261	66.685 2.6254	0.096 0.212
	57.150 2.2500	66.675 2.6250	31.75 1.250	WJ-364220	67.6 15200	128 28900	4900	7500	0.0745	57.150 2.2500	57.137 2.2495	66.703 2.6261	66.685 2.6254	0.120 0.265
2⅝	60.325 2.3750	69.850 2.7500	38.10 1.500	WJ-384424	81.4 18300	167 37600	4600	7100	0.0815	60.325 2.3750	60.312 2.3745	69.878 2.7511	69.860 2.7504	0.151 0.334
2½	63.500 2.5000	73.025 2.8750	25.40 1.000	WJ-404616	55.6 12500	104 23400	4400	6700	0.0741	63.500 2.5000	63.487 2.4995	73.053 2.8761	73.035 2.8754	0.106 0.234

Load ratings are based on a minimum raceway hardness of 58 HRC or equivalent.

Minimum axial clearance should be 0.02 mm (0.008 in).

Shaft Dia.	F _w	E _w	B _c +0 -0.38 -0.015	Assembly Designation	C	C ₀	Grease	Oil	C _g	S (ISO h5)		H (ISO G6)		Wt.
										Mounting Dimensions				
										Max.	Min.	Max.	Min.	
in	mm in	mm in	mm in		kN lbf		min ⁻¹			mm in	mm in	mm in	mm in	kg lbs
2½	63.500 2.5000	73.025 2.8750	31.75 1.250	WJ-404620	69.8 15700	139 31400	4400	6700	0.0797	63.500 2.5000	63.487 2.4995	73.053 2.8761	73.035 2.8754	0.132 0.292
	63.500 2.5000	73.025 2.8750	38.10 1.500	WJ-404624	83.2 18700	173 39100	4400	6700	0.0842	63.500 2.5000	63.487 2.4995	73.053 2.8761	73.035 2.8754	0.179 0.395
2¾	69.850 2.7500	79.375 3.1250	25.40 1.000	WJ-445016	57.8 13000	112.54 25300	4000	6100	0.0788	69.850 2.7500	69.837 2.7495	79.403 3.1261	79.385 3.1254	0.116 0.256
3	76.200 3.0000	85.725 3.3750	25.40 1.000	WJ-485416	59.6 13400	120.55 27100	3600	5600	0.0833	76.200 3.0000	76.187 2.9995	85.761 3.3764	85.738 3.3755	0.126 0.278
	76.200 3.0000	85.725 3.3750	38.10 1.500	WJ-485424	85.4 19200	191.72 43100	3600	5600	0.0935	76.200 3.0000	76.187 2.9995	85.761 3.3764	85.738 3.3755	0.189 0.416
3¼	82.550 3.2500	92.075 3.6250	25.40 1.000	WJ-525816	61.4 13800	128.55 28900	3300	5100	0.0878	82.550 3.2500	82.535 3.2494	92.111 3.6264	92.088 3.6255	0.136 0.299
	82.550 3.2500	92.075 3.6250	38.10 1.500	WJ-525824	88.1 19800	204.62 46000	3300	5100	0.0985	82.550 3.2500	82.535 3.2494	92.111 3.6264	92.088 3.6255	0.220 0.486
3½	88.900 3.5000	98.425 3.8750	25.40 1.000	WJ-566216	63.2 14200	136.56 30700	3100	4700	0.0922	88.900 3.5000	88.885 3.4994	98.461 3.8764	98.438 3.8755	0.146 0.321
	88.900 3.5000	101.600 4.0000	25.40 1.000	WJ-566416	79.6 17900	150.35 33800	3100	4800	0.0903	88.900 3.5000	88.885 3.4994	101.636 4.0014	101.613 4.0005	0.197 0.435
	88.900 3.5000	101.600 4.0000	38.10 1.500	WJ-566424	113 25600	237.53 53400	3100	4800	0.1011	88.900 3.5000	88.885 3.4994	101.636 4.0014	101.613 4.0005	0.296 0.653
4	101.600 4.0000	114.300 4.5000	25.40 1.000	WJ-647216	83.6 18800	166.59 37450	2700	4200	0.0983	101.600 4.0000	101.585 3.9994	114.336 4.5014	114.313 4.5005	0.224 0.493
	101.600 4.0000	114.300 4.5000	38.10 1.500	WJ-647224	119 26800	263.33 59200	2700	4200	0.1102	101.600 4.0000	101.585 3.9994	114.336 4.5014	114.313 4.5005	0.335 0.739
5	127.000 5.0000	152.400 6.0000	38.10 1.500	WJ-809624	211 47600	365.20 82100	2200	3400	0.1196	127.000 5.0000	126.982 4.9993	152.438 6.0015	152.415 6.0006	1.018 2.244



NOTES

DRAWN CUP NEEDLE ROLLER BEARINGS

Overview: Drawn cup needle roller bearings support radial loads and reduce friction between rotating components, with a drawn outer shell serving as a raceway for the rollers. The small cross section of the drawn cup bearing provides high load-carrying capability with minimum required space. Drawn cup bearings are easily installed with a press fit in the housing.

- **Sizes:** 3 mm – 139.7 mm (0.1181 in – 5.5000 in) bore.
- **Markets:** Transmissions, transfer cases, engines, valve trains, steering and braking systems, axle supports, outboard engines, power tools, copiers, fax machines, paper-moving equipment and appliances.
- **Features:** Available in two basic designs: full complement and caged.
- **Benefits:** Full complement bearings handle high radial load-carrying capability. Caged bearings provide high speed and maximum lubricant-retention capability.

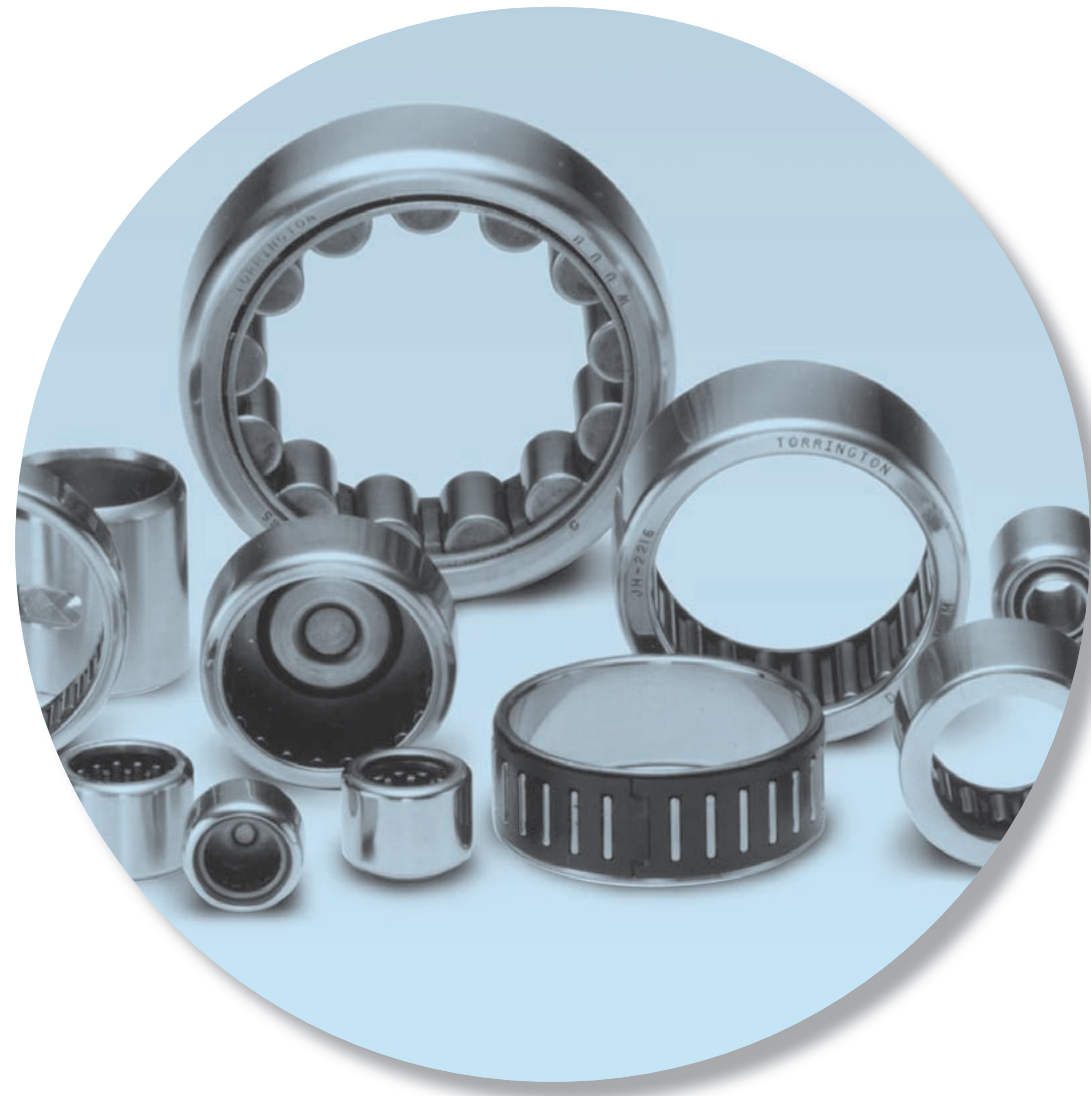

Drawn Cup Needle Roller Bearings – Metric Nominal Dimensions

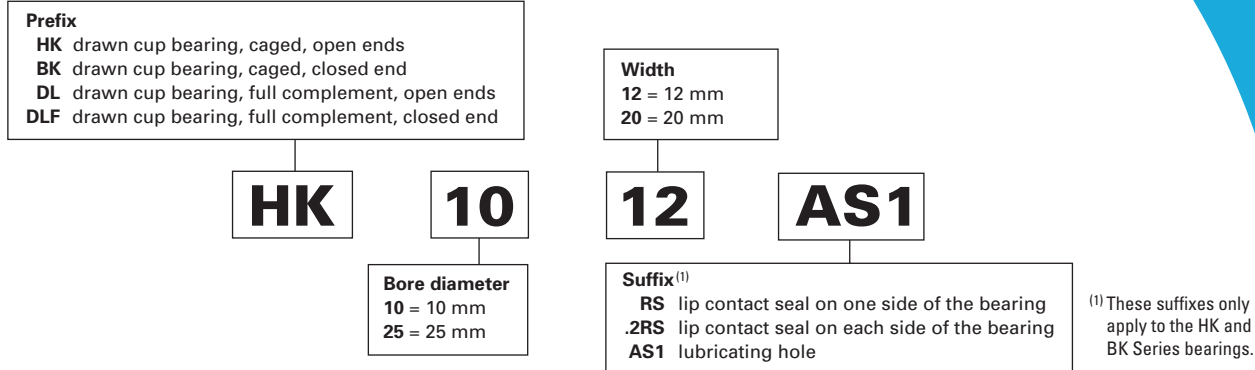

Inner Rings – Metric Nominal Dimensions

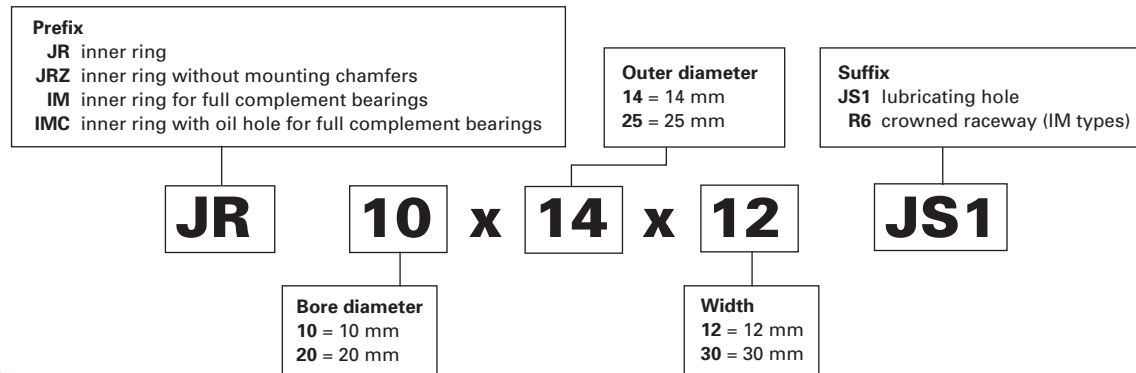

Drawn Cup Needle Roller Bearings – Inch Nominal Dimensions

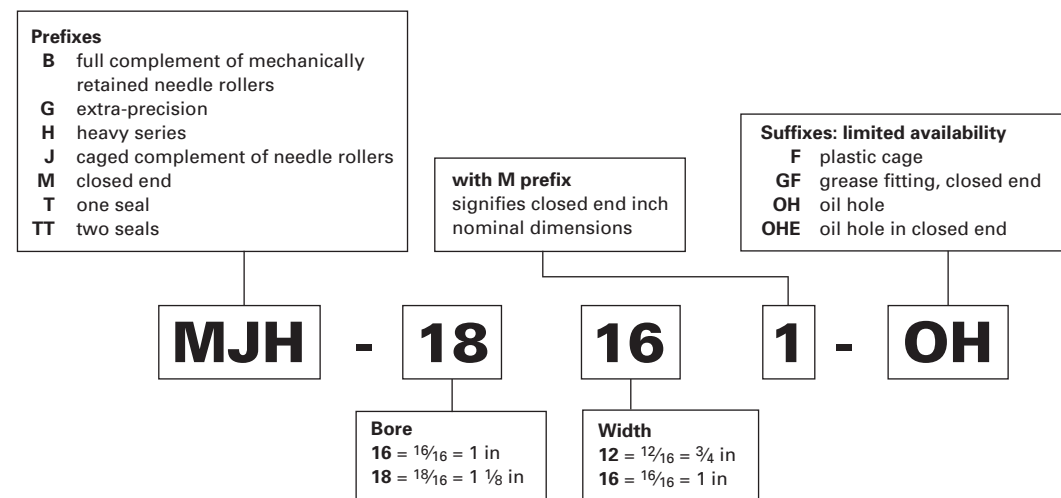

Inner Rings (with four-digit number) Inch Nominal Dimensions

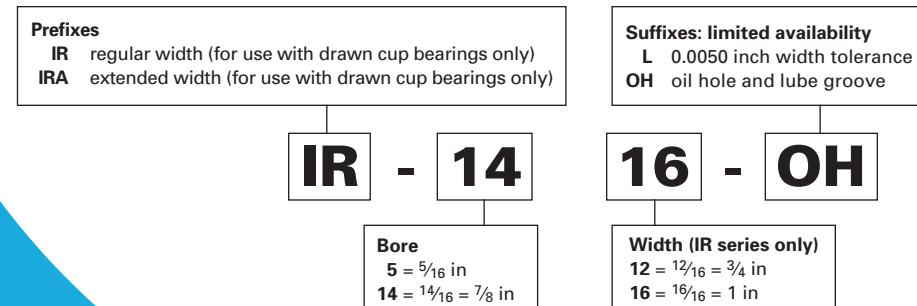

Drawn Cup Needle Roller Bearings

	<i>Page</i>
Introduction	B-44
Open Ends, Closed One End – Metric Series	B-50
Sealed Bearings – Metric Series.....	B-60
Inner Rings – Metric Series.....	B-64
Full Complement Open Ends, Closed One End – Metric Series	B-76
Inner Rings for Full Complement Drawn cup Needle Roller Bearings – Metric Series	B-82
Drawn Cup Needle Roller Bearings – Inch Series.....	B-85
Full Complement Bearings, Open Ends, Closed One End – Inch Series	B-92
Extra-Precision Bearings – Inch Series	B-106
Caged Bearings – Open Ends, Closed One End – Inch Series	B-110
Sealed Drawn Cup Bearings – Inch Series	B-118
Inner Rings for Inch Series Drawn Cup Bearings	B-120



DRAWN CUP NEEDLE ROLLER BEARINGS

METRIC SERIES

When a rolling bearing is needed for a compact and economic design and where it is not practical to harden and grind the housing bore, or where the housing materials are of low rigidity such as cast iron, aluminum or even plastics – drawn cup needle roller bearings should be considered.

REFERENCE STANDARDS ARE:

- ISO 3245 – rolling bearings – needle roller bearings, drawn cup, without inner ring, boundary dimensions and tolerances.
ANSI/ABMA 18.1 – needle roller bearings – radial, metric design.
DIN 618 – needle roller bearings with cage – drawn cups with open end, drawn cup with closed end.

Before selecting specific drawn cup needle roller bearings, please review the engineering section of this catalog.

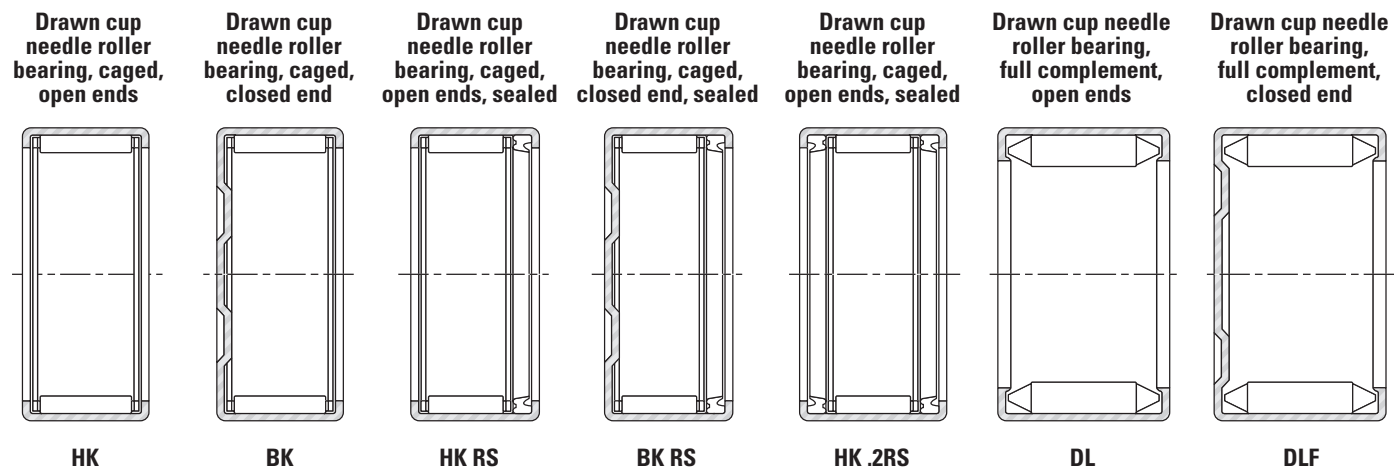

Fig. B-6. Types of metric series drawn cup needle roller bearings

Table with 2 columns: Suffixes and description. Rows include AS1 (lubricating hole), RS (lip contact seal on one side of the bearing), and .2RS (lip contact seal on each side of the bearing).

CONSTRUCTION

The prefix letters in metric series drawn cup bearing designations denote whether the bearings are made with a full complement of needle rollers or caged needle rollers. The use of a full complement of needle rollers is indicated by the prefix code letters DL or DLF, and for use of caged needle rollers by the prefix code letters HK or BK.

The outer ring, in the form of a cup, is accurately drawn and no subsequent machining is performed. Drawn cup needle roller bearings of series HK and DL have open ends. The HK series also are available with one seal, HK RS, and with two seals, HK .2RS. The stamped lip of a drawn cup needle roller bearing of series HK RS is at the seal end.

Drawn cup needle roller bearings of series BK and DLF are closed at one end. They are used for shaft-end mounting. The open end is typically not sealed.

The one-piece steel cage used in HK and BK series drawn cup bearings is designed to provide rigidity and minimize wear. This cage design separates the needle roller guiding and retention functions.

Drawn cup needle roller bearings also are available with two needle roller and cage assemblies. They have a lubricating hole in the outer ring. Metric series drawn cup bearings with one needle roller and cage assembly may be made available on request with a lubricating hole, indicated by suffix AS1.

SEALED BEARINGS

The HK series drawn cup bearings are offered with integral seals. The tables of dimensions on pages B-60 to B-63, indicate those sizes available with lip contact seals. The seal lip design achieves a light and constant contact with the inner raceway throughout the range of mounted bearing clearances, thereby ensuring positive sealing and low frictional drag.

Sealed drawn cup bearings are intended to retain grease or non-pressurized oil within a bearing while also preventing contaminants from entering the raceway area.

Details of shaft design for sealed bearings are given in the engineering section of this catalog.

The standard lip contact seals are compatible with common lubricating oils and petroleum based fuels; but, they are adversely affected by certain fire-resistant hydraulic fluids and most common solvents. Sealed drawn cup bearings are normally filled with a high-quality lithium soap-based general purpose grease. The seal material and grease properties limit the bearing operating temperature between -30° C and +100° C (-22° F and +212° F).

If the operating temperature must be outside of the range for the seals mentioned here, or if the seals are exposed to unusual fluids, please consult your representative.

BEARING MOUNTING FITS AND INTERNAL CLEARANCE

Drawn cup bearings are manufactured to a degree of precision that will satisfy the radial clearance requirements of most applications. The total radial clearance for an installed drawn cup bearing results from the buildup of manufacturing tolerances of the housing bore, the inner raceway diameter and the bearing, as well as the minimum radial clearance required for the application (reference Table B-6 on page B-46).

For metric series caged drawn cup bearings requiring close control of radial internal clearance, the suggested housing bore tolerance is N6 and h5 tolerance for the inner raceway diameter. When such exacting close control of radial internal clearance is not required, the user may select N7 housing bore and h6 inner raceway diameter tolerances.

For metric series full complement drawn cup bearings requiring close control of radial internal clearance, the suggested housing bore tolerance is H6 and h5 tolerance for the inner raceway diameter. When such exacting close control of radial internal clearance is not required, the user may select H7 housing bore and h6 inner raceway diameter tolerances.

TOLERANCES FOR HOUSING MATERIALS OF LOW RIGIDITY

The suggested housing bore tolerance for metric series caged drawn cup bearings used in housings made from materials of low rigidity or steel housings of small section is R6. To maintain normal radial internal clearance, the inner raceway diameter tolerance should be h5. When such exacting close control of radial internal clearance is not required, the user may select R7 housing bore and h6 inner raceway diameter tolerances.

The suggested housing bore tolerance for metric series full complement drawn cup bearings used in housings made from materials of low rigidity or steel housings of small section is M6. To maintain normal radial internal clearance, the inner raceway diameter tolerance should be h5. When such exacting close control of radial internal clearance is not required, the user may select M7 housing bore and h6 inner raceway diameter tolerances.

OUTER RING ROTATION

For metric series caged drawn cup bearing applications where the outer ring rotates with respect to the load, it is suggested that both the housing bore and the inner raceway diameter be reduced using R6 and f5 tolerance practice respectively. The user may select R7 housing bore and f6 inner raceway diameter tolerance when such exacting close control of radial internal clearance is not required.

For metric series full complement drawn cup bearings applications where the outer ring rotates with respect to the load, it is suggested that both the housing bore and the inner raceway diameter tolerance be reduced using is M6 and f5 tolerance practice respectively. The user may select M7 housing bore and f6 inner raceway diameter tolerances when such exacting close control of radial internal clearance is not required.

OSCILLATING MOTION

Metric series drawn cup bearing applications involving oscillating motion may require reduced radial internal clearances. This reduction may be accomplished by increasing the inner raceway diameter using j5 tolerance. When such exacting close control of radial clearance is not required, the user may select j6 inner raceway diameter tolerances.



Table B-6. Metric mounting fits

Bearing type	Operating condition	Shaft fit (recommended internal radial clearances)	Housing fit (recommended internal radial clearances)
HK, BK, HKRS, HK.2RS	One piece heavy section steel or cast iron housing	h5 (h6)	N6 (N7)
DL, DLF	One piece heavy section steel or cast iron housing	h5 (h6)	H6 (H7)
HK, BK, HKRS, HK.2RS	Housing material of low rigidity	h5 (h6)	R6 (R7)
DL, DLF	Housing material of low rigidity	h5 (h6)	M6 (M7)
HK, BK, HKRS, HK.2RS	Outer ring rotation (one piece heavy section steel or cast iron housing)	f5 (f6)	R6 (R7)
DL, DLF	Outer ring rotation (one piece heavy section steel or cast iron housing)	f5 (f6)	M6 (M7)
HK, BK, HKRS, HK.2RS	Oscillating motion	j5 (j6)	(1)
DL, DLF	Oscillating Motion	j5 (j6)	(1)

(1) Tolerance dependent on housing design.

INNER RINGS

When it becomes impractical to meet the shaft raceway design requirements (hardness, case depth, surface finish, etc.) outlined in the engineering section of this catalog, standard inner rings may be used with metric series drawn cup bearings. It is suggested that when metric series inner rings are used with metric series drawn cup bearings, they should be mounted with a loose transition fit on the shaft using g5 shaft diameter tolerance. The inner ring should be end-clamped against a shoulder. If a tight transition fit must be used (shaft diameter tolerance h5) to keep the inner ring from rotating relative to the shaft, the inner ring outer diameter, as mounted, must not exceed the raceway diameter required by the drawn cup bearing for the particular application. In case the outer diameter of the inner ring, when mounted on the shaft, exceeds the required raceway diameter for the matching drawn cup bearing, it should be ground to proper diameter while mounted on the shaft. When such exacting close control of radial internal clearance is not required the user may select g6 or h5 shaft diameter tolerances.

LOAD RATING FACTORS

DYNAMIC LOADS

Drawn cup needle roller bearings can accommodate only radial loads.

$$P = F_r$$

P = The maximum dynamic radial load that may be applied to a drawn cup bearing based on the dynamic load rating, C given in the bearing tables. This load should be $\leq C/3$.

STATIC LOADS

$$f_0 = \frac{C_0}{P_0}$$

f₀ = static load safety factor

C₀ = basic static load rating (kN)

P₀ = maximum applied static load (kN)

To ensure satisfactory operation of drawn cup needle roller bearings, under all types of conditions, the static load safety factor f₀ should be ≥ 3 .

ADJUSTED RATING LIFE

When application data includes details of operating temperature, oil viscosity, operating speed and the applied load meets the $\leq C/3$ condition adjusted rating life may be evaluated using the information given in the engineering section.

INSPECTION OF DRAWN CUP NEEDLE ROLLER BEARINGS

Although the bearing cup is accurately drawn from strip steel, because of its fairly thin section, it may go out-of-round during heat treatment. When the bearing is pressed into a true round housing, or ring gage of correct size and wall thickness, it becomes round and is sized properly. *For this reason, it is incorrect to inspect an unmounted drawn cup bearing by measuring the outer diameter.*

The correct method for inspecting the bearing size is to:

1. Press the bearing into a ring gage of proper size.
2. Plug the bearing bore with the appropriate "go" and "no go" gages, or measure it with a tapered arbor (lathe mandrel).

The "go" gage size is the minimum needle roller complement bore diameter. The "no go" gage size is larger than the maximum needle roller complement bore diameter by 0.002 mm (0.0001 in).

NOTE

SPECIAL BEARINGS. There are bearings available with other cage designs, and materials such as reinforced engineered polymer for use where operating conditions permit.

Table B-7. Caged bearing gage sizes

Nominal bore diameter	Ring gage ⁽¹⁾	Needle roller complement bore diameter	
		Max.	Min.
mm in	mm in	mm in	mm in
3.000 0.1181	6.484 0.2553	3.024 0.1191	3.006 0.1183
4.000 0.1575	7.984 0.3143	4.028 0.1586	4.010 0.1579
5.000 0.1969	8.984 0.3537	5.028 0.1980	5.010 0.1972
6.000 0.2362	9.984 0.3931	6.028 0.2373	6.010 0.2366
7.000 0.2756	10.980 0.4323	7.031 0.2768	7.013 0.2761
8.000 0.3150	11.980 0.4717	8.031 0.3162	8.013 0.3155
9.000 0.3543	12.980 0.5110	9.031 0.3555	9.013 0.3548
10.000 0.3937	13.980 0.5504	10.031 0.3949	10.013 0.3942
12.000 0.4724	15.980 0.6291	12.034 0.4738	12.016 0.4731
12.000 0.4724	17.980 0.7079	12.034 0.4738	12.016 0.4731
13.000 0.5118	18.976 0.7471	13.034 0.5131	13.016 0.5124
14.000 0.5512	19.976 0.7865	14.034 0.5525	14.016 0.5518
15.000 0.5906	20.976 0.8258	15.034 0.5919	15.016 0.5912
16.000 0.6299	21.976 0.8652	16.034 0.6313	16.016 0.6306
17.000 0.6693	22.976 0.9046	17.034 0.6706	17.016 0.6699
18.000 0.7087	23.976 0.9439	18.034 0.7100	18.016 0.7093
20.000 0.7874	25.976 1.0227	20.041 0.7890	20.020 0.7882
22.000 0.8661	27.976 1.1014	22.041 0.8678	22.020 0.8669
25.000 0.9843	31.972 1.2587	25.041 0.9859	25.020 0.9850
28.000 1.1024	34.972 1.3769	28.041 1.1040	28.020 1.1031
30.000 1.1811	36.972 1.4556	30.041 1.1827	30.020 1.1819
35.000 1.3780	41.972 1.6524	35.050 1.3799	35.025 1.3789
40.000 1.5750	46.972 1.8493	40.050 1.5768	40.025 1.5758
45.000 1.7717	51.967 2.0459	45.050 1.7736	45.025 1.7726
50.000 1.9685	57.967 2.2822	50.050 1.9705	50.025 1.9695
60.000 2.3622	67.967 2.6759	60.060 2.3646	60.030 2.3634

(1) The ring gage sizes are in accordance with ISO N6 lower limit.

Table B-8. Full complement bearing gage sizes

Nominal bore diameter	Ring gage	Needle roller complement bore diameter	
		Max.	Min.
mm in	mm in	mm in	mm in
6.000 0.2362	12.000 0.4724	6.034 0.2376	6.009 0.2366
8.000 0.3150	14.000 0.5512	8.034 0.3163	8.009 0.3153
9.000 0.3543	14.000 0.5512	9.034 0.3557	9.009 0.3547
10.000 0.3937	16.000 0.6299	10.034 0.3950	10.009 0.3941
12.000 0.4724	18.000 0.7087	10.033 0.3950	10.009 0.3941
13.000 0.5118	19.000 0.7480	13.033 0.5131	13.009 0.5122
14.000 0.5512	20.000 0.7874	14.033 0.5525	14.009 0.5515
15.000 0.5906	21.000 0.8268	15.033 0.5919	15.009 0.5909
16.000 0.6299	22.000 0.8661	16.033 0.6312	16.009 0.6303
17.000 0.6693	23.000 0.9055	17.033 0.6706	17.009 0.6696
18.000 0.7087	24.000 0.9449	18.033 0.7100	18.009 0.7090
20.000 0.7874	26.000 1.0236	20.033 0.7887	20.009 0.7878
22.000 0.8661	28.000 1.1024	22.033 0.8674	22.009 0.8665
25.000 0.9843	33.000 1.2992	25.039 0.9858	25.015 0.9848
28.000 1.1024	36.000 1.4173	28.039 1.1039	28.015 1.1030
30.000 1.1811	38.000 1.4961	30.039 1.1826	30.015 1.1817
35.000 1.3780	43.000 1.6929	35.039 1.3795	35.015 1.3785
40.000 1.5748	48.000 1.8898	40.039 1.5763	40.015 1.5754
44.000 1.7323	52.000 2.0472	44.039 1.7338	44.015 1.7329
47.000 1.8504	55.000 2.1654	47.039 1.8519	47.015 1.8510
50.000 1.9685	58.000 2.2835	50.039 1.9700	50.015 1.9691
55.000 2.1654	63.000 2.4803	55.039 2.1669	55.015 2.1659



INSTALLATION PROCEDURES

GENERAL INSTALLATION REQUIREMENTS

- A drawn cup bearing must be pressed into its housing.
- An installation tool, similar to the ones illustrated must be used in conjunction with a standard press.
- The bearing must not be hammered into its housing, even in conjunction with the proper assembly mandrel.
- The bearing must not be pressed tightly against a shoulder in the housing.
- If it is necessary to use a shouldered housing, the depth of the housing bore must be sufficient to ensure that the housing shoulder fillet, as well as the shoulder face, clears the bearing.
- The installation tool must be coaxial with the housing bore.

INSTALLATION OF OPEN ENDS CAGED BEARINGS

It is advisable to utilize a positive stop on the press tool to locate the bearing properly in the housing. The assembly tool should have a leader or a pilot, as shown, to aid in starting the bearing true in the housing. The "O" ring shown on the drawing may be used to assist in holding the bearing on the installation tool. The bearing should be installed with the stamped end (the end with the identification markings) against the angled shoulder of the pressing tool.

- A – 0.40 mm (0.016 in) less than housing bore
- B – 0.08 mm (0.003 in) less than shaft diameter
- C – distance bearing will be inset into housing, minimum of 0.20 mm (0.008 in)
- D – pilot length should be length of bearing less 0.80 mm (0.030 in)
- E – approximately 1/2 D

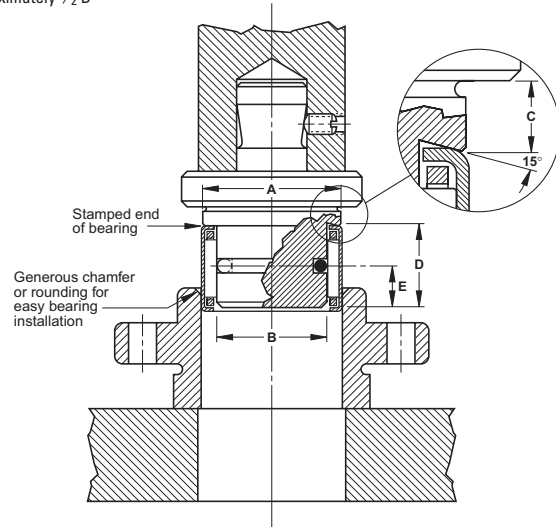

INSTALLATION OF CLOSED END CAGED BEARINGS

Bearing can be piloted from below for installation.

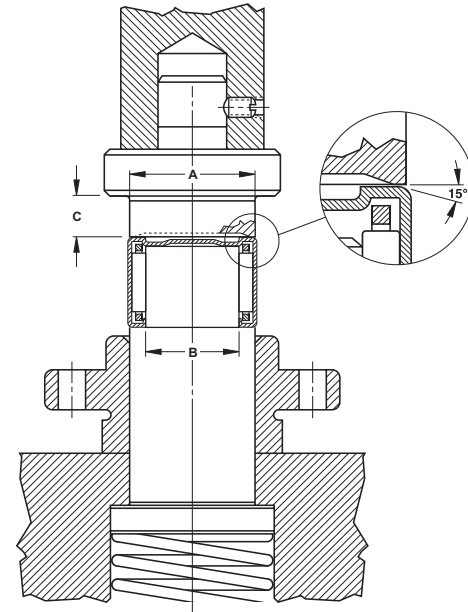

EXTRACTION FROM A STRAIGHT HOUSING (CAGED AND FULL COMPLEMENT BEARINGS)

Bearing can be extracted by pushing it through the housing. After extraction, the drawn cup bearing should not be reused.

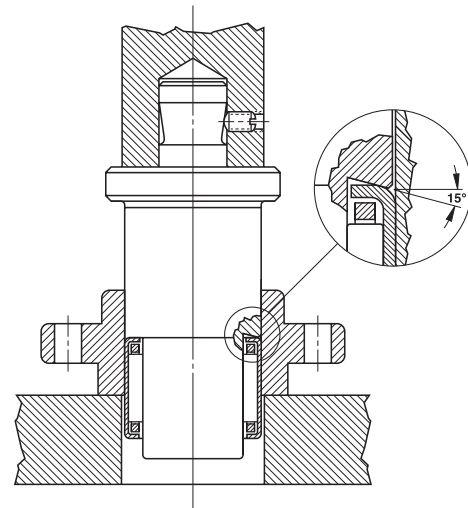

INSTALLATION OF OPEN ENDS FULL COMPLEMENT BEARINGS

It is advisable to utilize a positive stop on the press tool to locate the bearing properly in the housing. The assembly tool should have a leader or a pilot, as shown, to aid in starting the bearing true in the housing. The ball detent shown on the drawing is used to assist in aligning the rollers of a full complement bearing during installation and to hold the bearing on the installation tool. The bearing should be installed with the marked end (the end with identification markings) against the angled shoulder of the pressing tool.

- A – 0.40 mm (0.016 in) less than housing bore
- B – 0.08 mm (0.003 in) less than shaft diameter
- C – distance bearing will be inset into housing, minimum of 0.20 mm (0.008 in)
- D – pilot length should be length of bearing less 0.80 mm (0.030 in)
- E – approximately 1/2 D

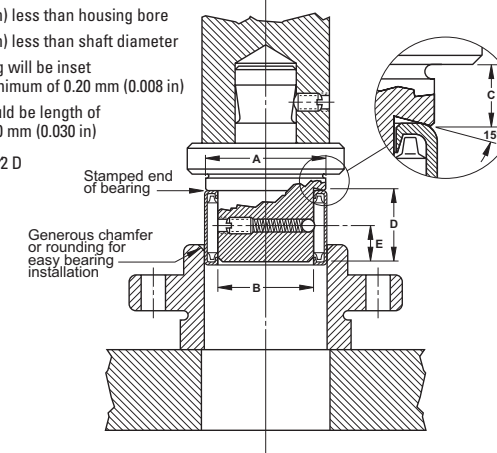

EXTRACTION FROM A SHOULDERED OR DEAD END HOUSING (CAGED AND FULL COMPLEMENT BEARINGS) (with space between the bearing and the housing shoulder)

Bearings may be extracted from shouldered or dead end housings with a common bearing puller tool as shown. This type of tool is slotted in two places at right angles to form four prongs. The four puller prongs are pressed together and inserted into the space between the end of the bearing and the shoulder. The prongs are forced outward by inserting the expansion rod, and then the bearing is extracted. Do not reuse the bearing after extraction.

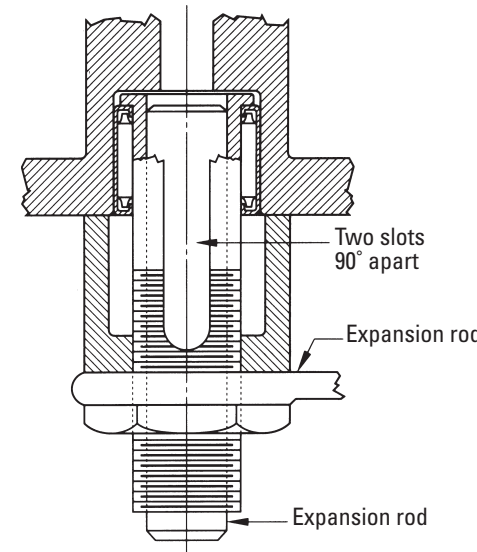

INSTALLATION OF CLOSED END FULL COMPLEMENT BEARINGS

The installation tool combines all the features of the tool used to install open end bearings, but the pilot is spring loaded and is part of the press bed.

The angled shoulder of the pressing tool should bear against the closed end with the bearing held on the pilot to aid in starting the bearing true in the housing.

- A – 0.40 mm (0.016 in) less than housing bore
- B – 0.08 mm (0.003 in) less than shaft diameter
- C – distance bearing will be inset into housing, minimum of 0.20 mm (0.008 in)

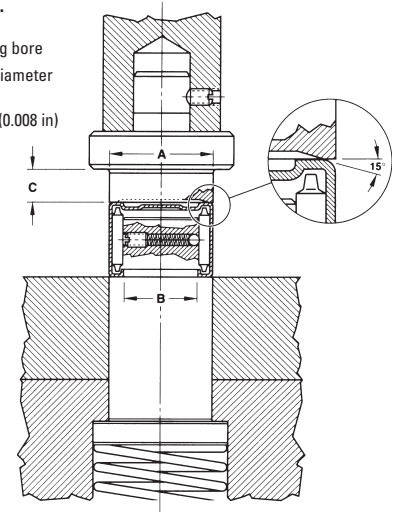

EXTRACTION FROM A SHOULDERED HOUSING (CAGED AND FULL COMPLEMENT BEARINGS) (with bearing pressed up close to the shoulder)

The tool to be used, as shown, is of a similar type described for a shouldered or dead end housing, but the rollers must first be removed from the bearing.

The four segment puller jaws are collapsed and slipped into the empty cup. The jaws are then forced outward into the cup bore by means of the tapered expansion rod. The jaws should bear on the lip as near as possible to the cup bore. The cup is then pressed out from the top.

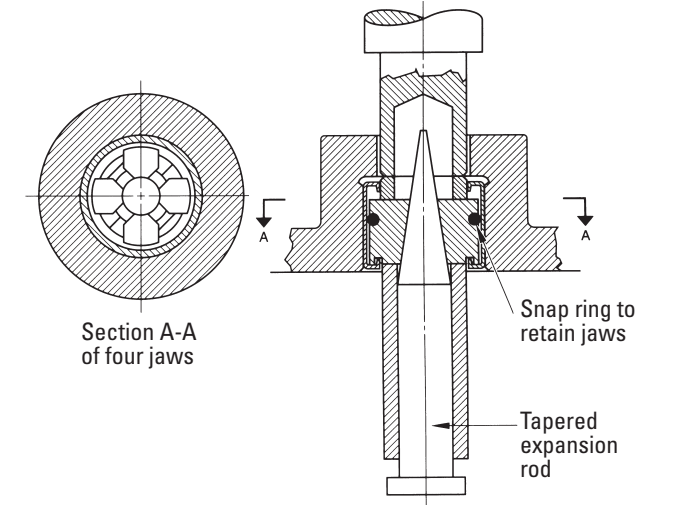



NEEDLE ROLLER BEARINGS

**OPEN ENDS,
CLOSED ONE END**

METRIC SERIES

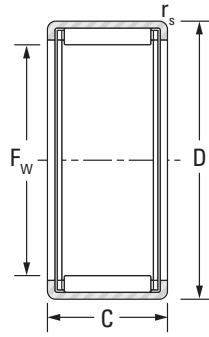

HK

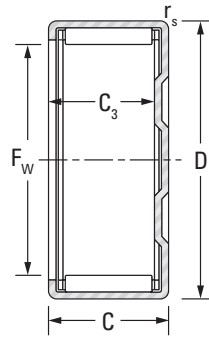

BK

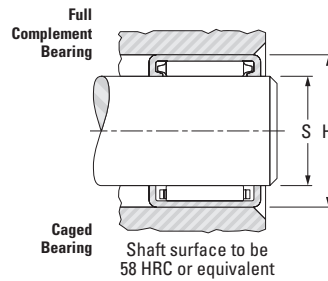

See Engineering section for discussion of shaft and housing design.

Shaft Dia.	F _w	D	C	C _{3 min}	r _{s min}	Bearing Designation	Load Ratings		Speed Rating		C _g
							Dynamic	Static	Grease	Oil	
							C	C ₀			
3 0.1181	3 0.1181	6.5 0.2559	6 0.236	5.20 0.205	0.30 0.012	BK0306	1.20 270	0.78 175	30000	46000	0.0065
	3 0.1181	6.5 0.2559	6 0.236	—	0.30 0.012	HK0306	1.60 360	1.14 256	30000	46000	0.0065
4 0.1575	4 0.1575	8 0.3150	8 0.315	6.40 0.252	0.40 0.016	BK0408	1.83 411	1.32 297	25000	39000	0.0083
	4 0.1575	8 0.3150	8 0.315	—	0.40 0.016	HK0408	1.88 423	1.38 310	25000	39000	0.0083
5 0.1969	5 0.1969	9 0.3543	9 0.354	7.40 0.291	0.40 0.016	BK0509	2.52 567	2.07 465	23000	36000	0.0100
	5 0.1969	9 0.3543	9 0.354	—	0.40 0.016	HK0509	2.52 567	2.07 465	23000	36000	0.0100
6 0.2362	6 0.2362	10 0.3937	8 0.315	6.40 0.252	0.40 0.016	BK0608	2.34 526	1.95 438	22000	33000	0.0105
	6 0.2362	10 0.3937	8 0.315	—	0.40 0.016	HK0608	2.34 526	1.95 438	22000	33000	0.0105
	6 0.2362	10 0.3937	9 0.354	7.40 0.291	0.40 0.016	BK0609	3.14 706	2.85 641	22000	33000	0.0116
	6 0.2362	10 0.3937	9 0.354	—	0.40 0.016	HK0609	3.14 706	2.85 641	22000	33000	0.0116
7 0.2756	7 0.2756	11 0.4331	9 0.354	7.40 0.291	0.40 0.016	BK0709	3.24 728	3.10 697	21000	32000	0.0125
	7 0.2756	11 0.4331	9 0.354	—	0.40 0.016	HK0709	3.23 726	3.05 686	21000	32000	0.0125
8 0.3150	8 0.3150	12 0.4724	8 0.315	6.40 0.252	0.40 0.016	BK0808	2.90 652	2.73 614	20000	31000	0.0128
	8 0.3150	12 0.4724	8 0.315	—	0.40 0.016	HK0808	2.90 652	2.73 614	20000	31000	0.0128
	8 0.3150	12 0.4724	10 0.394	8.40 0.331	0.40 0.016	BK0810	3.93 883	4.14 931	20000	31000	0.0184
	8 0.3150	12 0.4724	10 0.394	—	0.40 0.016	HK0810	3.95 888	4.07 915	20000	31000	0.0186
9 0.3543	9 0.3543	13 0.5118	10 0.394	8.40 0.331	0.40 0.016	BK0910	4.57 1030	5.07 1140	19000	30000	0.0206
	9 0.3543	13 0.5118	10 0.394	—	0.40 0.016	HK0910	4.57 1030	5.07 1140	19000	30000	0.0206
	9 0.3543	13 0.5118	12 0.472	10.40 0.409	0.40 0.016	BK0912	5.65 1270	6.65 1490	19000	30000	0.0220
	9 0.3543	13 0.5118	12 0.472	—	0.40 0.016	HK0912	5.65 1270	6.65 1490	19000	30000	0.0220
10 0.3937	10 0.3937	14 0.5512	10 0.394	8.40 0.331	0.40 0.016	BK1010	4.78 1070	5.51 1240	19000	29000	0.0219
	10 0.3937	14 0.5512	10 0.394	—	0.40 0.016	HK1010	4.78 1070	5.51 1240	19000	29000	0.0219
	10 0.3937	14 0.5512	12 0.472	10.40 0.409	0.40 0.016	BK1012	5.90 1330	7.23 1630	19000	29000	0.0239
	10 0.3937	14 0.5512	12 0.472	—	0.40 0.016	HK1012	5.90 1330	7.23 1630	19000	29000	0.0235

Drawn Cup Needle Roller Bearings

Wt.	S (h5)		H (N6)		Inspection		C _g	Mounting Inner Ring (pg B-65 to B-74)	Shaft Dia.	
	Recommended Mounting Dimension				Ring Gage	Plug Gage				
	Max.	Min.	Max.	Min.		Go				No Go
kg lbs	mm in	mm in	mm in	mm in					mm in	
0.001 0.002	3 0.1181	2.996 0.118	6.493 0.2556	6.484 0.2553	6.484 0.2553	3.006 0.1183	3.026 0.1191		3 0.1181	
0.001 0.002	3 0.1181	2.996 0.118	6.493 0.2556	6.484 0.2553	6.484 0.2553	3.006 0.1183	3.026 0.1191		3 0.1181	
0.002 0.004	4 0.1575	3.995 0.1573	7.993 0.3147	7.984 0.3143	7.984 0.3143	4.010 0.1579	4.030 0.1587		4 0.1575	
0.002 0.004	4 0.1575	3.995 0.1573	7.993 0.3147	7.984 0.3143	7.984 0.3143	4.010 0.1579	4.030 0.1587		4 0.1575	
0.002 0.004	5 0.1969	4.995 0.1967	8.993 0.3541	8.984 0.3537	8.984 0.3537	5.010 0.1972	5.030 0.1980		5 0.1969	
0.002 0.004	5 0.1969	4.995 0.1967	8.993 0.3541	8.984 0.3537	8.984 0.3537	5.010 0.1972	5.030 0.1980		5 0.1969	
0.002 0.004	6 0.2362	5.995 0.236	9.993 0.3934	9.984 0.3931	9.984 0.3931	6.010 0.2366	6.030 0.2374		6 0.2362	
0.002 0.004	6 0.2362	5.995 0.236	9.993 0.3934	9.984 0.3931	9.984 0.3931	6.010 0.2366	6.030 0.2374		6 0.2362	
0.003 0.007	6 0.2362	5.995 0.236	9.993 0.3934	9.984 0.3931	9.984 0.3931	6.010 0.2366	6.030 0.2374		6 0.2362	
0.002 0.004	6 0.2362	5.995 0.236	9.993 0.3934	9.984 0.3931	9.984 0.3931	6.010 0.2366	6.030 0.2374		6 0.2362	
0.003 0.007	7 0.2756	6.994 0.2754	10.991 0.4327	10.980 0.4323	10.980 0.4323	7.013 0.2761	7.033 0.2769		7 0.2756	
0.003 0.007	7 0.2756	6.994 0.2754	10.991 0.4327	10.980 0.4323	10.980 0.4323	7.013 0.2761	7.033 0.2769		7 0.2756	
0.003 0.007	8 0.315	7.994 0.3147	11.991 0.4721	11.980 0.4717	11.980 0.4717	8.013 0.3155	8.033 0.3163		8 0.315	
0.003 0.007	8 0.315	7.994 0.3147	11.991 0.4721	11.980 0.4717	11.980 0.4717	8.013 0.3155	8.033 0.3163		8 0.315	
0.004 0.009	8 0.315	7.994 0.3147	11.991 0.4721	11.980 0.4717	11.980 0.4717	8.013 0.3155	8.033 0.3163	0.0241	JR5x8x12	
0.004 0.009	8 0.315	7.994 0.3147	11.991 0.4721	11.980 0.4717	11.980 0.4717	8.013 0.3155	8.033 0.3163	0.0244	JR5x8x12	
0.004 0.009	9 0.3543	8.994 0.3541	12.991 0.5115	12.980 0.5110	12.980 0.5110	9.013 0.3548	9.033 0.3556	0.0270	JR6x9x12	
0.004 0.009	9 0.3543	8.994 0.3541	12.991 0.5115	12.980 0.5110	12.980 0.5110	9.013 0.3548	9.033 0.3556	0.0270	JR6x9x12	
0.005 0.011	9 0.3543	8.994 0.3541	12.991 0.5115	12.980 0.5110	12.980 0.5110	9.013 0.3548	9.033 0.3556	0.0289	JR6x9x12	
0.005 0.011	9 0.3543	8.994 0.3541	12.991 0.5115	12.980 0.5110	12.980 0.5110	9.013 0.3548	9.033 0.3556	0.0289	JR6x9x12	
0.004 0.009	10 0.3937	9.994 0.3935	13.991 0.5508	13.980 0.5504	13.980 0.5504	10.013 0.3942	10.033 0.3950	0.0287	JR7x10x10,5	
0.004 0.009	10 0.3937	9.994 0.3935	13.991 0.5508	13.980 0.5504	13.980 0.5504	10.013 0.3942	10.033 0.3950	0.0287	JR7x10x10,5	
0.006 0.013	10 0.3937	9.994 0.3935	13.991 0.5508	13.980 0.5504	13.980 0.5504	10.013 0.3942	10.033 0.3950	0.0314	JR7x10x12	
0.005 0.011	10 0.3937	9.994 0.3935	13.991 0.5508	13.980 0.5504	13.980 0.5504	10.013 0.3942	10.033 0.3950	0.0308	JR7x10x12	

Continued on next page.



NEEDLE ROLLER BEARINGS

OPEN ENDS, CLOSED ONE END

— continued

METRIC SERIES

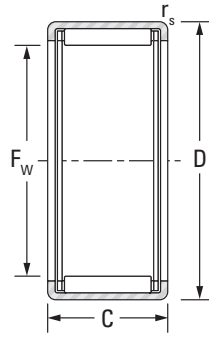

HK

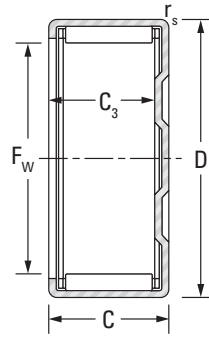

BK

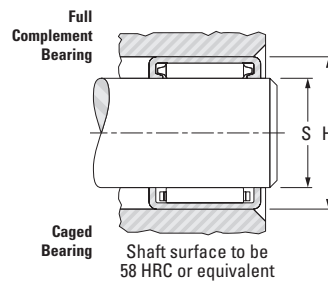

Shaft Dia.	F _w	D	C	C _{3 min}	r _{s min}	Bearing Designation	Load Ratings		Speed Rating		C _g
							Dynamic	Static	Grease	Oil	
							C	C ₀			
mm in	mm in	mm in	-0.3, -0.012	mm in	mm in		kN lbf		min ⁻¹		
10 0.3937	10 0.3937	14 0.5512	15 0.591	13.40 0.528	0.40 0.016	BK1015	7.49 1680	9.81 2210	19000	29000	0.0253
	10 0.3937	14 0.5512	15 0.591	—	0.40 0.016	HK1015	7.49 1680	9.81 2210	19000	29000	0.0253
12 0.4724	12 0.4724	16 0.6299	10 0.394	8.40 0.331	0.4 0.016	BK1210	4.96 1120	6.08 1370	18000	28000	0.0243
	12 0.4724	16 0.6299	10 0.394	—	0.4 0.016	HK1210	4.96 1120	6.08 1370	18000	28000	0.0243
	12 0.4724	18 0.7087	12 0.472	9.30 0.366	1 0.039	BK1212	6.61 1490	7.29 1640	14000	22000	0.0245
	12 0.4724	18 0.7087	12 0.472	—	1 0.039	HK1212	6.61 1490	7.29 1640	14000	22000	0.0245
13 0.5118	13 0.5118	19 0.7480	12 0.472	9.30 0.366	1 0.039	BK1312	6.92 1560	7.89 1770	14000	22000	0.0258
	13 0.5118	19 0.7480	12 0.472	—	1 0.039	HK1312	6.92 1560	7.89 1770	14000	22000	0.0258
14 0.5512	14 0.5512	20 0.7874	12 0.472	9.30 0.366	1 0.039	BK1412	7.21 1620	8.50 1910	14000	21000	0.0271
	14 0.5512	20 0.7874	12 0.472	—	1 0.039	HK1412	7.21 1620	8.50 1910	14000	21000	0.0271
15 0.5906	15 0.5906	21 0.8268	12 0.472	9.30 0.366	1 0.039	BK1512	7.16 1610	8.57 1930	14000	21000	0.0284
	15 0.5906	21 0.8268	12 0.472	—	1 0.039	HK1512	7.49 1680	9.11 2050	14000	21000	0.0284
	15 0.5906	21 0.8268	16 0.630	13.30 0.524	1 0.039	BK1516	10.70 2410	14.4 3240	14000	21000	0.0318
	15 0.5906	21 0.8268	16 0.630	—	1 0.039	HK1516	10.70 2410	14.4 3240	14000	21000	0.0318
	15 0.5906	21 0.8268	22 0.866	19.30 0.760	1 0.039	BK1522 ⁽¹⁾	13.50 3030	19.4 4360	14000	21000	0.0288
	15 0.5906	21 0.8268	22 0.866	—	1 0.039	HK1522 ⁽¹⁾	13.50 3030	19.4 4360	14000	21000	0.0288
16 0.6299	16 0.6299	22 0.8661	12 0.472	9.30 0.366	1 0.039	BK1612	7.76 1740	9.72 2190	14000	21000	0.0297
	16 0.6299	22 0.8661	12 0.472	—	1 0.039	HK1612	7.76 1740	9.72 2190	14000	21000	0.0297
	16 0.6299	22 0.8661	16 0.630	13.30 0.524	1 0.039	BK1616	11.1 2500	15.3 3440	14000	21000	0.0332
	16 0.6299	22 0.8661	16 0.630	—	1 0.039	HK1616	11.1 2500	15.3 3440	14000	21000	0.0332
	16 0.6299	22 0.8661	22 0.866	19.30 0.760	1 0.039	BK1622 ⁽¹⁾	13.4 3010	19.5 4380	14000	21000	0.0297
	16 0.6299	22 0.8661	22 0.866	—	1 0.039	HK1622 ⁽¹⁾	13.40 3010	19.5 4380	14000	21000	0.0297
17 0.6693	17 0.6693	23 0.9055	12 0.472	9.30 0.366	1 0.039	BK1712	8.12 1830	10.4 2340	13000	20000	0.0236
	17 0.6693	23 0.9055	12 0.472	—	1 0.039	HK1712	8.12 1830	10.4 2340	13000	20000	0.0236

See Engineering section for discussion of shaft and housing design.

⁽¹⁾ Drawn cup needle roller bearings with two needle roller and cage assemblies and one lubricating hole.

Drawn Cup Needle Roller Bearings

Wt.	S (h5)		H (N6)		Inspection		C _g	Mounting Inner Ring (pg B-65 to B-74)	Shaft Dia.	
	Recommended Mounting Dimension				Ring Gage	Plug Gage				
	Max.	Min.	Max.	Min.		Go				No Go
kg lbs	mm in	mm in	mm in	mm in					mm in	
0.006 0.013	10 0.3937	9.994 0.3935	13.991 0.5508	13.980 0.5504	13.980 0.5504	10.013 0.3942	10.033 0.3950	0.0332	JR7x10x16	10 0.3937
0.006 0.013	10 0.3937	9.994 0.3935	13.991 0.5508	13.980 0.5504	13.980 0.5504	10.013 0.3942	10.033 0.3950	0.0332	JR7x10x16	
0.006 0.013	12 0.4724	11.992 0.4721	15.991 0.6296	15.980 0.6291	15.980 0.6291	12.016 0.4731	12.036 0.4739	0.0319	JR8x12x10,5	12 0.4724
0.006 0.013	12 0.4724	11.992 0.4721	15.991 0.6296	15.980 0.6291	15.980 0.6291	12.016 0.4731	12.036 0.4739	0.0319	JR8x12x10,5	
0.012 0.026	12 0.4724	11.992 0.4721	17.991 0.7083	17.980 0.7079	17.980 0.7079	12.016 0.4731	12.036 0.4739	0.0321	JR8x12x12,5	
0.01 0.022	12 0.4724	11.992 0.4721	17.991 0.7083	17.980 0.7079	17.980 0.7079	12.016 0.4731	12.036 0.4739	0.0321	JR8x12x12,5	12 0.4724
0.012 0.026	13 0.5118	12.992 0.5115	18.989 0.7476	18.976 0.7471	18.976 0.7471	13.016 0.5124	13.036 0.5132	0.0338	JR10x13x12,5	13 0.5118
0.01 0.022	13 0.5118	12.992 0.5115	18.989 0.7476	18.976 0.7471	18.976 0.7471	13.016 0.5124	13.036 0.5132	0.0338	JR10x13x12,5	
0.014 0.031	14 0.5512	13.992 0.5509	19.989 0.7870	19.976 0.7865	19.976 0.7865	14.016 0.5518	14.036 0.5526	0.0356	JR10x14x12	14 0.5512
0.011 0.024	14 0.5512	13.992 0.5509	19.989 0.7870	19.976 0.7865	19.976 0.7865	14.016 0.5518	14.036 0.5526	0.0356	JR10x14x12	
0.015 0.033	15 0.5906	14.992 0.5902	20.989 0.8263	20.976 0.8258	20.976 0.8258	15.016 0.5912	15.036 0.5920	0.0373	JR12x15x12,5	15 0.5906
0.012 0.026	15 0.5906	14.992 0.5902	20.989 0.8263	20.976 0.8258	20.976 0.8258	15.016 0.5912	15.036 0.5920	0.0373	JR12x15x12,5	
0.019 0.042	15 0.5906	14.992 0.5902	20.989 0.8263	20.976 0.8258	20.976 0.8258	15.016 0.5912	15.036 0.5920	0.0417	JR12x15x16,5	
0.018 0.040	15 0.5906	14.992 0.5902	20.989 0.8263	20.976 0.8258	20.976 0.8258	15.016 0.5912	15.036 0.5920	0.0417	JR12x15x16,5	
0.022 0.049	15 0.5906	14.992 0.5902	20.989 0.8263	20.976 0.8258	20.976 0.8258	15.016 0.5912	15.036 0.5920	0.0378	JR12x15x22,5	
0.024 0.053	15 0.5906	14.992 0.5902	20.989 0.8263	20.976 0.8258	20.976 0.8258	15.016 0.5912	15.036 0.5920	0.0378	JR12x15x22,5	
0.016 0.035	16 0.6299	15.992 0.6296	21.989 0.8657	21.976 0.8652	21.976 0.8652	16.016 0.6306	16.036 0.6313	0.0390	JR12x16x12	16 0.6299
0.012 0.026	16 0.6299	15.992 0.6296	21.989 0.8657	21.976 0.8652	21.976 0.8652	16.016 0.6306	16.036 0.6313	0.0390	JR12x16x12	
0.02 0.044	16 0.6299	15.992 0.6296	21.989 0.8657	21.976 0.8652	21.976 0.8652	16.016 0.6306	16.036 0.6313	0.0436	JR12x16x16	
0.016 0.035	16 0.6299	15.992 0.6296	21.989 0.8657	21.976 0.8652	21.976 0.8652	16.016 0.6306	16.036 0.6313	0.0436	JR12x16x16	
0.028 0.062	16 0.6299	15.992 0.6296	21.989 0.8657	21.976 0.8652	21.976 0.8652	16.016 0.6306	16.036 0.6313	0.0390	JR12x16x22	
0.022 0.049	16 0.6299	15.992 0.6296	21.989 0.8657	21.976 0.8652	21.976 0.8652	16.016 0.6306	16.036 0.6313	0.0390	JR12x16x22	
0.018 0.040	17 0.6693	16.992 0.6690	22.989 0.9051	22.976 0.9046	22.976 0.9046	17.016 0.6699	17.036 0.6707			17 0.6693
0.013 0.029	17 0.6693	16.992 0.6690	22.989 0.9051	22.976 0.9046	22.976 0.9046	17.016 0.6699	17.036 0.6707			

Continued on next page.



NEEDLE ROLLER BEARINGS

OPEN ENDS, CLOSED ONE END

— continued

METRIC SERIES

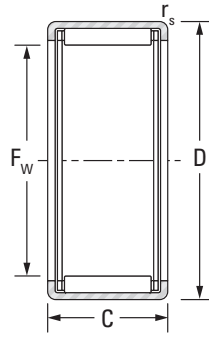

HK

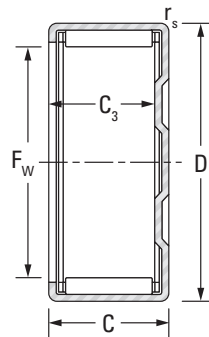

BK

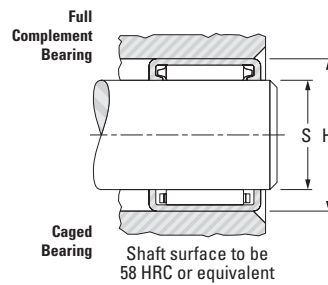

See Engineering section for discussion of shaft and housing design.

Shaft Dia. mm in	F _w mm in	D mm in	C mm in	C _{3 min} mm in	r _{s min} mm in	Bearing Designation	Load Ratings		Speed Rating		C _g
							Dynamic	Static	Grease	Oil	
							C	C ₀			
18 0.7087	18 0.7087	24 0.9449	12 0.472	9.30 0.366	1 0.039	BK1812	8.41 1890	11.11 2500	12000	18000	0.0246
	18 0.7087	24 0.9449	12 0.472	—	1 0.039	HK1812	8.41 1890	11.11 2500	12000	18000	0.0246
	18 0.7087	24 0.9449	16 0.630	13.30 0.524	1 0.039	BK1816	11.6 2610	16.8 3780	12000	18000	0.0357
	18 0.7087	24 0.9449	16 0.630	—	1 0.039	HK1816	11.6 2610	16.8 3780	12000	18000	0.0357
20 0.7874	20 0.7874	26 1.0236	12 0.472	9.3 0.366	1 0.039	BK2012	8.97 2020	12.5 2810	11000	16000	0.0347
	20 0.7874	26 1.0236	12 0.472	—	1 0.039	HK2012	8.97 2020	12.5 2810	11000	16000	0.0347
	20 0.7874	26 1.0236	16 0.630	13.3 0.524	1 0.039	BK2016	12.40 2790	18.90 4250	11000	16000	0.0385
20 0.7874	20 0.7874	26 1.0236	16 0.630	—	1 0.039	HK2016	12.40 2790	18.90 4250	11000	16000	0.0385
	20 0.7874	26 1.0236	20 0.787	17.3 0.681	1 0.039	BK2020	15.50 3480	25.30 5690	11000	16000	0.0414
	20 0.7874	26 1.0236	20 0.787	—	1 0.039	HK2020	15.90 3570	26.20 5890	11000	16000	0.0414
	20 0.7874	26 1.0236	30 1.181	27.3 1.075	1 0.039	BK2030 ⁽¹⁾	21.20 4770	37.80 8500	11000	16000	0.0385
	20 0.7874	26 1.0236	30 1.181	—	1 0.039	HK2030 ⁽¹⁾	21.20 4770	37.80 8500	11000	16000	0.0385
22 0.8661	22 0.8661	28 1.1024	10 0.394	9.3 0.366	1 0.039	BK2210	7.06 1587	9.49 2133	9600	15000	
	22 0.8661	28 1.1024	10 0.394	—	1 0.039	HK2210	7.06 1587	9.49 2133	9600	15000	
	22 0.8661	28 1.1024	12 0.472	9.3 0.366	1 0.039	BK2212	9.81 2210	14.50 3260	9600	15000	0.0375
	22 0.8661	28 1.1024	12 0.472	—	1 0.039	HK2212	9.81 2210	14.50 3260	9600	15000	0.0382
	22 0.8661	28 1.1024	16 0.630	13.3 0.524	1 0.039	BK2216	13.10 2940	20.90 4700	9600	15000	0.0412
	22 0.8661	28 1.1024	16 0.630	—	1 0.039	HK2216	13.10 2940	20.90 4700	9600	15000	0.0412
	22 0.8661	28 1.1024	20 0.787	17.3 0.681	1 0.039	BK2220	15.30 3440	25.50 5730	9600	15000	0.0432
	22 0.8661	28 1.1024	20 0.787	—	1 0.039	HK2220	15.30 3440	25.50 5730	9600	15000	0.0432
25 0.9843	25 0.9843	32 1.2598	12 0.472	9.30 0.366	1 0.039	BK2512	10.90 2450	14.70 3300	8500	13000	0.0295
	25 0.9843	32 1.2598	12 0.472	—	1 0.039	HK2512	10.90 2450	14.70 3300	8500	13000	0.0295
	25 0.9843	32 1.2598	16 0.630	13.3 0.524	1 0.039	BK2516	15.60 3510	23.50 5280	8500	13000	0.0434
	25 0.9843	32 1.2598	16 0.630	—	1 0.039	HK2516	15.60 3510	23.50 5280	8500	13000	0.0434

⁽¹⁾ Drawn cup needle roller bearings with two needle roller and cage assemblies and one lubricating hole.

Drawn Cup Needle Roller Bearings

Wt. kg lbs	S (h5)		H (N6)		Inspection		C _g	Mounting Inner Ring (pg B-65 to B-74)	Shaft Dia. mm in	
	Recommended Mounting Dimension				Ring Gage	Plug Gage				
	Max.	Min.	Max.	Min.		Go				No Go
0.017 0.037	18 0.7087	17.992 0.7083	23.989 0.9444	23.976 0.9439	23.976 0.9439	18.016 0.7093	18.036 0.7101		18 0.7087	
0.015 0.033	18 0.7087	17.992 0.7083	23.989 0.9444	23.976 0.9439	23.976 0.9439	18.016 0.7093	18.036 0.7101			
0.022 0.049	18 0.7087	17.992 0.7083	23.989 0.9444	23.976 0.9439	23.976 0.9439	18.016 0.7093	18.036 0.7101	0.0468	JR15x18x16,5	
0.018 0.040	18 0.7087	17.992 0.7083	23.989 0.9444	23.976 0.9439	23.976 0.9439	18.016 0.7093	18.036 0.7101	0.0468	JR15x18x16,5	
0.017 0.037	20 0.7874	19.991 0.7870	25.989 1.0232	25.976 1.0227	25.976 1.0227	20.020 0.7882	20.043 0.7891	0.0455	JR15x20x12	
0.015 0.033	20 0.7874	19.991 0.7870	25.989 1.0232	25.976 1.0227	25.976 1.0227	20.020 0.7882	20.043 0.7891	0.0455	JR15x20x12	
0.024 0.053	20 0.7874	19.991 0.7870	25.989 1.0232	25.976 1.0227	25.976 1.0227	20.020 0.7882	20.043 0.7891	0.0505	JR17x20x16,5	
0.022 0.049	20 0.7874	19.991 0.7870	25.989 1.0232	25.976 1.0227	25.976 1.0227	20.020 0.7882	20.043 0.7891	0.0505	JR17x20x16,5	
0.027 0.060	20 0.7874	19.991 0.7870	25.989 1.0232	25.976 1.0227	25.976 1.0227	20.020 0.7882	20.043 0.7891	0.0543	JR17x20x20,5	
0.025 0.055	20 0.7874	19.991 0.7870	25.989 1.0232	25.976 1.0227	25.976 1.0227	20.020 0.7882	20.043 0.7891	0.0543	JR17x20x20,5	
0.043 0.095	20 0.7874	19.991 0.7870	25.989 1.0232	25.976 1.0227	25.976 1.0227	20.020 0.7882	20.043 0.7891	0.0505	JR17x20x30,5	
0.041 0.090	20 0.7874	19.991 0.7870	25.989 1.0232	25.976 1.0227	25.976 1.0227	20.020 0.7882	20.043 0.7891	0.0505	JR17x20x30,5	
0.013 0.029	22 0.8661	21.991 0.8658	27.989 1.1019	27.976 1.1014	27.976 1.1014	22.020 0.8669	22.043 0.8678		22 0.8661	
0.013 0.029	22 0.8661	21.991 0.8658	27.989 1.1019	27.976 1.1014	27.976 1.1014	22.020 0.8669	22.043 0.8678			
0.02 0.044	22 0.8661	21.991 0.8658	27.989 1.1019	27.976 1.1014	27.976 1.1014	22.020 0.8669	22.043 0.8678	0.0492	JR17x22x13	
0.015 0.033	22 0.8661	21.991 0.8658	27.989 1.1019	27.976 1.1014	27.976 1.1014	22.020 0.8669	22.043 0.8678	0.0501	JR17x22x13	
0.027 0.060	22 0.8661	21.991 0.8658	27.989 1.1019	27.976 1.1014	27.976 1.1014	22.020 0.8669	22.043 0.8678	0.0541	JR17x22x16	
0.022 0.049	22 0.8661	21.991 0.8658	27.989 1.1019	27.976 1.1014	27.976 1.1014	22.020 0.8669	22.043 0.8678	0.0541	JR17x22x16	
0.028 0.062	22 0.8661	21.991 0.8658	27.989 1.1019	27.976 1.1014	27.976 1.1014	22.020 0.8669	22.043 0.8678	0.0567	JR17x22x23	
0.026 0.057	22 0.8661	21.991 0.8658	27.989 1.1019	27.976 1.1014	27.976 1.1014	22.020 0.8669	22.043 0.8678	0.0567	JR17x22x23	
0.025 0.055	25 0.9843	24.991 0.9839	31.988 1.2594	31.972 1.2587	31.972 1.2587	25.020 0.9850	25.043 0.9859		25 0.9843	
0.021 0.046	25 0.9843	24.991 0.9839	31.988 1.2594	31.972 1.2587	31.972 1.2587	25.020 0.985	25.043 0.9859			
0.031 0.068	25 0.9843	24.991 0.9839	31.988 1.2594	31.972 1.2587	31.972 1.2587	25.020 0.9850	25.043 0.9859	0.0569	JR20x25x17	
0.028 0.062	25 0.9843	24.991 0.9839	31.988 1.2594	31.972 1.2587	31.972 1.2587	25.020 0.9850	25.043 0.9859	0.0569	JR20x25x17	

Continued on next page.



NEEDLE ROLLER BEARINGS

**OPEN ENDS,
CLOSED ONE END**

— continued

METRIC SERIES

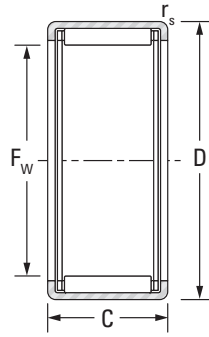

HK

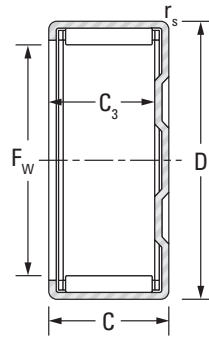

BK

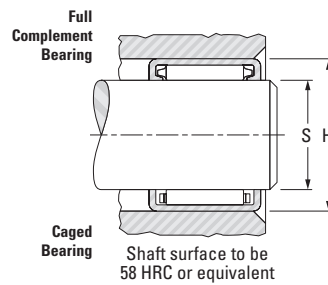

See Engineering section for discussion of shaft and housing design.

Shaft Dia.	F _w	D	C	C _{3 min}	r _{s min}	Bearing Designation	Load Ratings		Speed Rating		C _g
							Dynamic	Static	Grease	Oil	
							C	C ₀			
mm in	mm in	mm in	mm in	mm in	mm in		kN lbf	min ⁻¹			
25 0.9843	25 0.9843	32 1.2598	20 0.787	17.3 0.681	1 0.039	BK2520	20.60 4630	33.40 7510	8500	13000	0.0474
						HK2520	20.60 4630	33.40 7510			
						BK2526	25.70 5780	44.40 9980			
						HK2526	25.70 5780	44.40 9980			
						BK2538 ⁽¹⁾	35.30 7940	66.90 15000			
						HK2538 ⁽¹⁾	35.30 7940	66.90 15000			
28 1.1024	28 1.1024	35 1.3780	16 0.630	13.30 0.524	1 0.039	BK2816	15.9 3570	24.9 5600	7500	12000	0.0462
						HK2816	15.9 3570	24.9 5600			
						BK2820	20.9 4700	35.3 7940			
						HK2820	20.9 4700	35.3 7940			
						BK3012	11.6 2610	16.8 3780			
						HK3012	12.0 2700	17.7 3980			
30 1.1811	30 1.1811	37 1.4567	12 0.472	9.3 0.366	1 0.039	BK3016	16.8 3780	27.3 6140	7000	11000	0.0488
						HK3016	16.8 3780	27.3 6140			
						BK3020	22.4 5040	39.6 8900			
						HK3020	22.4 5040	39.6 8900			
						BK3026	27.4 6160	51.2 11500			
						HK3026	27.4 6160	51.2 11500			
30 1.1811	30 1.1811	37 1.4567	16 0.630	13.30 0.524	1 0.039	BK3038 ⁽¹⁾	38.4 8630	79.2 17800	7000	11000	0.0535
						HK3038 ⁽¹⁾	38.4 8630	79.2 17800			
						BK3512	13.0 2920	20.6 4630			
						HK3512	13.0 2920	20.6 4630			
						BK3516	17.4 3910	29.9 6720			
						HK3516	17.4 3910	29.9 6720			
35 1.3780	35 1.3780	42 1.6535	12 0.472	—	1 0.039	BK3520	24.5 5510	46.8 10520	5900	9100	0.0597
						HK3520	24.5 5510	46.8 10520			
						BK3520	24.5 5510	46.8 10520			
						HK3520	24.5 5510	46.8 10520			

⁽¹⁾ Drawn cup needle roller bearings with two needle roller and cage assemblies and one lubricating hole.

Drawn Cup Needle Roller Bearings

Wt.	S (h5)		H (N6)		Inspection		C _g	Mounting Inner Ring (pg B-65 to B-74)	Shaft Dia.	
	Recommended Mounting Dimension				Ring Gage	Plug Gage				
	Max.	Min.	Max.	Min.		Go				No Go
kg lbs	mm in	mm in	mm in	mm in					mm in	
0.043 0.095	25 0.9843	24.991 0.9839	31.988 1.2594	31.972 1.2587	31.972 1.2587	25.020 0.9850	25.043 0.9859	0.0622	JR20x25x20,5	25 0.9843
0.051 0.112	25 0.9843	24.991 0.9839	31.988 1.2594	31.972 1.2587	31.972 1.2587	25.020 0.9850	25.043 0.9859	0.0666	JR20x25x26,5	
0.077 0.170	25 0.9843	24.991 0.9839	31.988 1.2594	31.972 1.2587	31.972 1.2587	25.020 0.985	25.043 0.9859	0.0622	JR20x25x38,5	
0.038 0.084	28 1.1024	27.991 1.1020	34.988 1.3775	34.972 1.3769	34.972 1.3769	28.020 1.1031	28.043 1.1041	0.0606	JR22x28x17	28 1.1024
0.047 0.104	28 1.1024	27.991 1.1020	34.988 1.3775	34.972 1.3769	34.972 1.3769	28.020 1.1031	28.043 1.1041	0.0661	JR22x28x20,5	
0.031 0.068	30 1.1811	29.991 1.1807	36.988 1.4562	36.972 1.4556	36.972 1.4556	30.020 1.1819	30.043 1.1828	0.0640	JR25x30x17	30 1.1811
0.041 0.090	30 1.1811	29.991 1.1807	36.988 1.4562	36.972 1.4556	36.972 1.4556	30.020 1.1819	30.043 1.1828	0.0640	JR25x30x17	
0.053 0.117	30 1.1811	29.991 1.1807	36.988 1.4562	36.972 1.4556	36.972 1.4556	30.020 1.1819	30.043 1.1828	0.0705	JR25x30x20,5	
0.067 0.148	30 1.1811	29.991 1.1807	36.988 1.4562	36.972 1.4556	36.972 1.4556	30.020 1.1819	30.043 1.1828	0.0748	JR25x30x26,5	
0.093 0.205	30 1.1811	29.991 1.1807	36.988 1.4562	36.972 1.4556	36.972 1.4556	30.020 1.1819	30.043 1.1828	0.0702	JR25x30x38,5	
0.028 0.062	35 1.3780	34.989 1.3775	41.988 1.6531	41.972 1.6524	41.972 1.6524	35.025 1.3789	35.052 1.3800	0.0701	JR30x35x17	35 1.3780
0.065 0.143	35 1.3780	34.989 1.3775	41.988 1.6531	41.972 1.6524	41.972 1.6524	35.025 1.3789	35.052 1.3800	0.0783	JR30x35x20,5	

Continued on next page.



NEEDLE ROLLER BEARINGS

**OPEN ENDS,
CLOSED ONE END**

— continued

METRIC SERIES

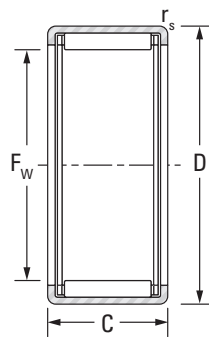

HK

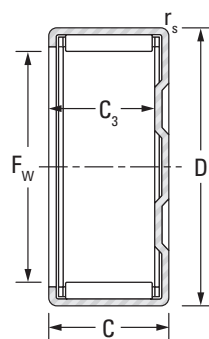

BK

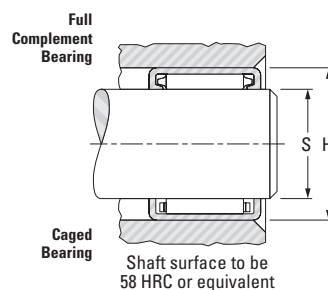

Shaft Dia.	F _w	D	C	C _{3 min}	r _{s min}	Bearing Designation	Load Ratings		Speed Rating		C _g
							Dynamic	Static	Grease	Oil	
							C	C ₀			
mm in	mm in	mm in	mm in	mm in	mm in		kN lbf	min ⁻¹			
			-0.3, -0.012								
40 1.5748	40 1.5748	47 1.8504	12 0.472	—	1 0.039	HK4012	14.7 3300	25.3 5690	5200	7900	0.0402
	40 1.5748	47 1.8504	16 0.630	—	1 0.039	HK4016	18.9 4250	34.8 7820	5200	7900	0.0589
	40 1.5748	47 1.8504	20 0.787	17.3 0.681	1 0.039	BK4020	25.1 5640	50.4 11300	5200	7900	0.0646
	40 1.5748	47 1.8504	20 0.787	—	1 0.039	HK4020	25.1 5640	50.4 11300	5200	7900	0.0646
45 1.7717	45 1.7717	52 2.0472	12 0.472	—	1 0.039	HK4512	14.1 3170	24.8 5580	4600	7000	0.0435
	45 1.7717	52 2.0472	16 0.630	—	1 0.039	HK4516	19.8 4450	38.5 8660	4600	7000	0.0637
	45 1.7717	52 2.0472	20 0.787	17.3 0.681	1 0.039	BK4520	26.3 5910	55.4 12500	4600	7000	0.0697
	45 1.7717	52 2.0472	20 0.787	—	1 0.039	HK4520	27.2 6110	58.2 13100	4600	7000	0.0697
50 1.9685	50 1.9685	58 2.2835	12 0.472	—	1 0.039	HK5012	17.0 3822	28.7 6452	4100	6300	
	50 1.9685	58 2.2835	20 0.787	—	1 0.039	HK5020	30.9 6950	62.2 14000	4100	6300	0.0714
	50 1.9685	58 2.2835	25 0.984	—	1 0.039	HK5025	35.5 7980	74.1 16700	4100	6300	0.0764
55 2.1654	55 2.1654	63 2.4803	20 0.787	—	1 0.039	HK5520	31.0 6969	64.4 14478	3700	5700	
60 2.3622	60 2.3622	68 2.6772	12 0.472	—	1 0.039	HK6012	17.2 3870	31.2 7010	3400	5200	0.0523
	60 2.3622	68 2.6772	20 0.787	—	1 0.039	HK6020	35.6 8003	79.5 17872	3400	5200	

Drawn Cup Needle Roller Bearings

Wt.	S (h5)		H (N6)		Inspection		C _g	Mounting Inner Ring (pg B-65 to B-74)	Shaft Dia.	
	Recommended Mounting Dimension				Ring Gage	Plug Gage				
	Max.	Min.	Max.	Min.		Go				No Go
kg lbs	mm in	mm in	mm in	mm in					mm in	
0.033 0.073	40 1.5748	39.989 1.5744	46.988 1.8499	46.972 1.8493	46.972 1.8493	40.025 1.5758	40.052 1.5769		40 1.5748	
0.042 0.093	40 1.5748	39.989 1.5744	46.988 1.8499	46.972 1.8493	46.972 1.8493	40.025 1.5758	40.052 1.5769	0.0773	JR35x40x17	
0.070 0.154	40 1.5748	39.989 1.5744	46.988 1.8499	46.972 1.8493	46.972 1.8493	40.025 1.5758	40.052 1.5769	0.0848	JR35x40x20,5	
0.060 0.132	40 1.5748	39.989 1.5744	46.988 1.8499	46.972 1.8493	46.972 1.8493	40.025 1.5758	40.052 1.5769	0.0848	JR35x40x20,5	
0.036 0.079	45 1.7717	44.989 1.7712	51.986 2.0467	51.967 2.0459	51.967 2.0459	45.025 1.7726	45.052 1.7737		45 1.7717	
0.048 0.106	45 1.7717	44.989 1.7712	51.986 2.0467	51.967 2.0459	51.967 2.0459	45.025 1.7726	45.052 1.7737	0.0836	JR40x45x17	
0.079 0.174	45 1.7717	44.989 1.7712	51.986 2.0467	51.967 2.0459	51.967 2.0459	45.025 1.7726	45.052 1.7737	0.0914	JR40x45x20,5	
0.059 0.130	45 1.7717	44.989 1.7712	51.986 2.0467	51.967 2.0459	51.967 2.0459	45.025 1.7726	45.052 1.7737	0.0914	JR40x45x20,5	
0.045 0.099	50 1.9685	49.989 1.9681	57.986 2.2829	57.967 2.2822	57.967 2.2822	50.025 1.9695	50.052 1.9706		50 1.9685	
0.072 0.159	50 1.9685	49.989 1.9681	57.986 2.2829	57.967 2.2822	57.967 2.2822	50.025 1.9695	50.052 1.9706	0.0937	JR45x50x20	
0.092 0.203	50 1.9685	49.989 1.9681	57.986 2.2829	57.967 2.2822	57.967 2.2822	50.025 1.9695	50.052 1.9706	0.1002	JR45x50x25,5	
0.079 0.174	55 2.1654	54.987 2.1648	62.986 2.4798	62.967 2.4790	62.967 2.4790	55.030 2.1665	55.062 2.1678		55 2.1654	
0.060 0.132	60 2.3622	59.987 2.3617	67.986 2.6766	67.967 2.6759	67.967 2.6759	60.030 2.3634	60.062 2.3646		60 2.3622	
0.090 0.198	60 2.3622	59.987 2.3617	67.986 2.6766	67.967 2.6759	67.967 2.6759	60.030 2.3634	60.062 2.3646		60 2.3622	
									JR50x60x20	

See Engineering section for discussion of shaft and housing design.



NEEDLE ROLLER BEARINGS

SEALED BEARINGS

METRIC SERIES

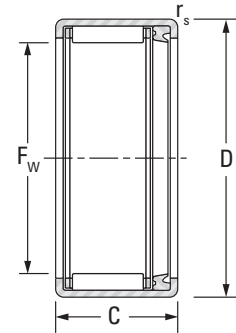

HK RS

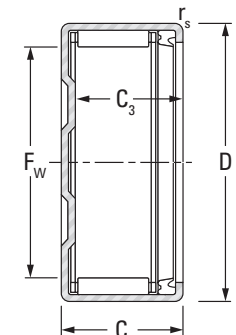

BK RS

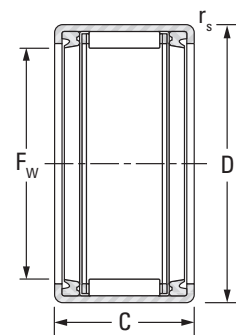

HK.2RS

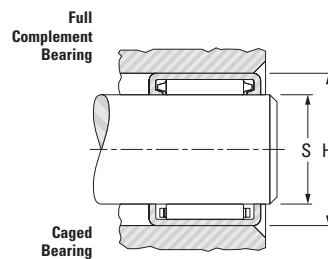

Shaft surface to be 58 HRC or equivalent

See Engineering section for discussion of shaft and housing design.

Shaft Dia.	F _w	D	C	C _{3 min}	r _{s min}	Bearing Designation	Load Ratings		Speed Rating Approx. Grease	C _g
							Dynamic	Static		
							C	C ₀		
mm in	mm in	mm in	-0.3, -0.012	mm in	mm in		kN lbf	min ⁻¹		
8 0.3150	8 0.3150	12 0.4724	10 0.394	—	0.4 0.016	HK0810RS	2.90 650	2.73 610	20000	0.0128
10 0.3937	10 0.3937	14 0.5512	12 0.472	—	0.4 0.016	HK1012RS	4.78 1070	5.51 1240	19000	0.0167
12 0.4724	12 0.4724	18 0.7087	14 0.551	—	1 0.039	HK1214RS	6.61 1490	7.29 1640	14000	0.0189
	12 0.4724	18 0.7087	16 0.630	—	1 0.039	HK1216.2RS	6.87 1540	7.65 1720	14000	0.0189
14 0.5512	14 0.5512	20 0.7874	14 0.551	11.6 0.457	1 0.039	BK1414RS	7.17 1610	8.41 1890	14000	0.0206
	14 0.5512	20 0.7874	14 0.551	—	1 0.039	HK1414RS	7.17 1610	8.41 1890	14000	0.0271
	14 0.5512	20 0.7874	16 0.630	—	1 0.039	HK1416.2RS	7.17 1610	8.41 1890	14000	0.0271
15 0.5906	15 0.5906	21 0.8268	14 0.551	11.3 0.445	1 0.039	BK1514RS	7.87 1770	9.69 2180	13000	0.0288
	15 0.5906	21 0.8268	14 0.551	—	1 0.039	HK1514RS	7.87 1770	9.69 2180	13000	0.0288
	15 0.5906	21 0.8268	16 0.630	—	1 0.039	HK1516.2RS	7.87 1770	9.69 2180	13000	0.0288
16 0.6299	16 0.6299	22 0.8661	14 0.551	—	1 0.039	HK1614RS	7.82 1760	9.76 2190	12000	0.0297
	16 0.6299	22 0.8661	16 0.630	—	1 0.039	HK1616.2RS	7.82 1760	9.76 2190	12000	0.0297
18 0.7087	18 0.7087	24 0.9449	14 0.551	—	1 0.039	HK1814RS	8.41 1890	11.10 2500	11000	0.0246
	18 0.7087	24 0.9449	16 0.630	—	1 0.039	HK1816.2RS	8.41 1890	11.10 2500	11000	0.0322
20 0.7874	20 0.7874	26 1.0236	16 0.630	—	1 0.039	HK2016.2RS	8.97 2020	12.50 2810	9700	0.0347
	20 0.7874	26 1.0236	18 0.709	—	1 0.039	HK2018RS	12.40 2790	18.90 4250	9700	0.0385
	20 0.7874	26 1.0236	20 0.787	—	1 0.039	HK2020.2RS	12.40 2790	18.90 4250	9700	0.0385
22 0.7874	22 0.7874	28 1.1024	16 0.630	—	1 0.039	HK2216.2RS	9.81 2210	14.50 3260	8800	0.0286
	22 0.8661	28 1.1024	18 0.709	—	1 0.039	HK2218RS	13.10 2950	20.90 4700	8800	0.0412
	22 0.8661	28 1.1024	20 0.787	—	1 0.039	HK2220.2RS	13.10 2950	20.90 4700	8800	0.0412
25 0.9843	25 0.9843	32 1.2598	16 0.630	—	1 0.039	HK2516.2RS	11.10 2500	15.10 3390	7800	0.0389
	25 0.9843	32 1.2598	18 0.709	—	1 0.039	HK2518RS	16.20 3640	24.60 5530	7800	0.0439
	25 0.9843	32 1.2598	20 0.787	—	1 0.039	HK2520.2RS	16.20 3640	24.60 5530	7800	0.0439
	25 0.9843	32 1.2598	22 0.866	—	1 0.039	HK2522RS	20.60 4630	33.40 7510	7800	0.0474

Drawn Cup Needle Roller Bearings

Wt.	S (h5)		H (N6)		Inspection		C _g	Mounting Inner Ring (pg B-65 to B-74)	Shaft Dia.	
	Recommended Mounting Dimension				Ring Gage	Plug Gage				
	Max.	Min.	Max.	Min.		Go				No Go
kg lbs	mm in	mm in	mm in	mm in					mm in	
0.004 0.009	8 0.3150	7.994 0.3147	11.991 0.4721	11.980 0.4717	11.980 0.4717	8.013 0.3155	8.033 0.3163		8 0.315	
0.006 0.013	10 0.3937	9.994 0.3935	13.991 0.5508	13.980 0.5504	13.980 0.5504	10.013 0.3942	10.033 0.3950		10 0.3937	
0.013 0.029	12 0.4724	11.992 0.4721	17.991 0.7083	17.980 0.7079	17.980 0.7079	12.016 0.4731	12.036 0.4739		12 0.4724	
0.016 0.035	12 0.4724	11.992 0.4721	17.991 0.7083	17.980 0.7079	17.980 0.7079	12.016 0.4731	12.036 0.4739			
0.014 0.031	14 0.5512	13.992 0.5509	19.989 0.7870	19.976 0.7865	19.976 0.7865	14.016 0.5518	14.036 0.5526		14 0.5512	
0.015 0.033	14 0.5512	13.992 0.5509	19.989 0.7870	19.976 0.7865	19.976 0.7865	14.016 0.5518	14.036 0.5526	0.0356	JR10x14x16	
0.014 0.031	14 0.5512	13.992 0.5509	19.989 0.7870	19.976 0.7865	19.976 0.7865	14.016 0.5518	14.036 0.5526	0.0356	JR10x14x20	
0.017 0.037	15 0.5906	14.992 0.5902	20.989 0.8263	20.976 0.8258	20.976 0.8258	15.016 0.5912	15.036 0.5920	0.0378	JR12x15x16,5	
0.016 0.035	15 0.5906	14.992 0.5902	20.989 0.8263	20.976 0.8258	20.976 0.8258	15.016 0.5912	15.036 0.5920	0.0378	JR12x15x16,5	
0.019 0.042	15 0.5906	14.992 0.5902	20.989 0.8263	20.976 0.8258	20.976 0.8258	15.016 0.5912	15.036 0.5920	0.0378	JR12x15x16,5	
0.014 0.031	16 0.6299	15.992 0.6296	21.989 0.8657	21.976 0.8652	21.976 0.8652	16.016 0.6306	16.036 0.6313	0.0390	JR12x16x16	
0.015 0.033	16 0.6299	15.992 0.6296	21.989 0.8657	21.976 0.8652	21.976 0.8652	16.016 0.6306	16.036 0.6313	0.0390	JR12x16x20	
0.018 0.040	18 0.7087	17.992 0.7083	23.989 0.9444	23.976 0.9439	23.976 0.9439	18.016 0.7093	18.036 0.7101	0.0321	JR15x18x16,5	
0.017 0.037	18 0.7087	17.992 0.7083	23.989 0.9444	23.976 0.9439	23.976 0.9439	18.016 0.7093	18.036 0.7101	0.0422	JR15x18x16,5	
0.023 0.051	20 0.7874	19.991 0.7870	25.989 1.0232	25.976 1.0227	25.976 1.0227	20.020 0.7882	20.043 0.7891	0.0455	JR17x20x16,5	
0.025 0.055	20 0.7874	19.991 0.7870	25.989 1.0232	25.976 1.0227	25.976 1.0227	20.020 0.7882	20.043 0.7891	0.0505	JR17x20x20,5	
0.028 0.062	20 0.7874	19.991 0.7870	25.989 1.0232	25.976 1.0227	25.976 1.0227	20.020 0.7882	20.043 0.7891	0.0505	JR17x20x20,5	
0.025 0.055	22 0.8661	21.991 0.8658	27.989 1.1019	27.976 1.1014	27.976 1.1014	22.020 0.8669	22.043 0.8678		22 0.7874	
0.027 0.060	22 0.8661	21.991 0.8658	27.989 1.1019	27.976 1.1014	27.976 1.1014	22.020 0.8669	22.043 0.8678	0.0541	JR17x22x23	
0.026 0.057	22 0.8661	21.991 0.8658	27.989 1.1019	27.976 1.1014	27.976 1.1014	22.020 0.8669	22.043 0.8678	0.0541	JR17x22x23	
0.030 0.066	25 0.9843	24.991 0.9839	31.988 1.2594	31.972 1.2587	31.972 1.2587	25.020 0.9850	25.043 0.9859	0.0510	JR20x25x17	
0.034 0.075	25 0.9843	24.991 0.9839	31.988 1.2594	31.972 1.2587	31.972 1.2587	25.020 0.9850	25.043 0.9859	0.0576	JR20x25x20,5	
0.033 0.073	25 0.9843	24.991 0.9839	31.988 1.2594	31.972 1.2587	31.972 1.2587	25.020 0.9850	25.043 0.9859	0.0576	JR20x25x20,5	
0.042 0.093	25 0.9843	24.991 0.9839	31.988 1.2594	31.972 1.2587	31.972 1.2587	25.020 0.9850	25.043 0.9859	0.0622	JR20x25x26	

Continued on next page.



NEEDLE ROLLER BEARINGS

SEALED BEARINGS

— continued

METRIC SERIES

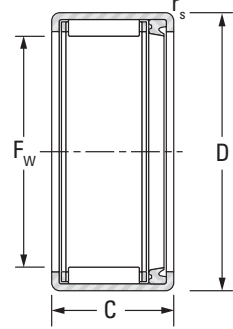

HK RS

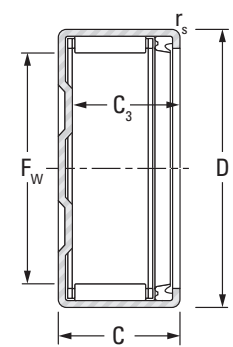

BK RS

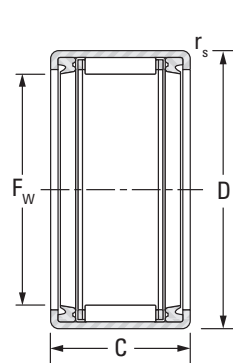

HK.2RS

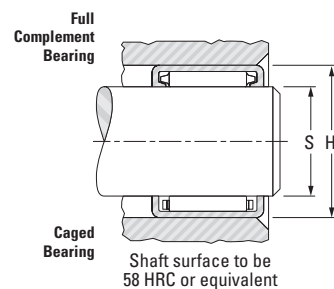

See Engineering section for discussion of shaft and housing design.

Shaft Dia.	F _w	D	C	C _{3 min}	r _{s min}	Bearing Designation	Load Ratings		Speed Rating Approx. Grease	C _g
							Dynamic	Static		
							C	C ₀		
mm in	mm in	mm in	-0.3, -0.012	mm in	mm in		kN lbf		min ⁻¹	
25 0.9843	25 0.9843	32 1.2598	24 0.945	—	1 0.039	HK2524.2RS	20.6 4630	33.4 7510	7800	0.0474
28 1.1024	28 1.1024	35 1.3780	20 0.787	—	1 0.039	HK2820.2RS	15.9 3570	24.9 5600	6900	0.0462
30 1.1811	30 1.1811	37 1.4567	16 0.63	—	1 0.039	HK3016.2RS	11.6 2610	16.8 3780	6500	0.0432
	30 1.1811	37 1.4567	18 0.709	—	1 0.039	HK3018RS	16.8 3780	27.3 6140	6500	0.0488
	30 1.1811	37 1.4567	20 0.787	—	1 0.039	HK3020.2RS	16.8 3780	27.3 6140	6500	0.0488
	30 1.1811	37 1.4567	22 0.866	—	1 0.039	HK3022RS	22.4 5040	39.6 8900	6500	0.0535
	30 1.1811	37 1.4567	24 0.945	—	1 0.039	HK3024.2RS	22.4 5040	39.6 8900	6500	0.0535
35 1.3780	35 1.3780	42 1.6535	16 0.630	—	1 0.039	HK3516.2RS	14.2 3190	23.2 5220	5500	0.0492
	35 1.3780	42 1.6535	18 0.709	—	1 0.039	HK3518RS	17.4 3910	29.9 6720	5500	0.0534
	35 1.3780	42 1.6535	20 0.787	—	1 0.039	HK3520.2RS	17.4 3910	29.9 6720	5500	0.0534
40 1.5748	40 1.5748	47 1.8504	16 0.630	—	1 0.039	HK4016.2RS	13.4 3010	22.4 5040	4900	0.0528
	40 1.5748	47 1.8504	18 0.709	—	1 0.039	HK4018RS	18.9 4250	34.8 7820	4900	0.0589
	40 1.5748	47 1.8504	20 0.787	—	1 0.039	HK4020.2RS	18.9 4250	34.8 7820	4900	0.0589
45 1.7717	45 1.7717	52 2.0472	18 0.709	—	1 0.039	HK4518RS	19.8 4450	38.5 8660	4300	0.0637
	45 1.7717	52 2.0472	20 0.787	—	1 0.039	HK4520.2RS	19.8 4450	38.5 8660	4300	0.0637
50 1.9685	50 1.9685	58 2.2835	22 0.866	—	1 0.039	HK5022RS	28.8 6470	56.6 12700	3900	0.0714
	50 1.9685	58 2.2835	24 0.945	—	1 0.039	HK5024.2RS	28.8 6470	56.6 12700	3900	0.0714

Drawn Cup Needle Roller Bearings

Wt.	S (h5)		H (N6)		Inspection		C _g	Mounting Inner Ring (pg B-65 to B-74)	Shaft Dia.	
	Recommended Mounting Dimension				Ring Gage	Plug Gage				
	Max.	Min.	Max.	Min.		Go				No Go
kg lbs	mm in	mm in	mm in	mm in					mm in	
0.047 0.104	25 0.9843	24.991 0.9839	31.988 1.2594	31.972 1.2587	31.972 1.2587	25.020 0.9850	25.043 0.9859	0.0622	JR20x25x26 25 0.9843	
0.042 0.093	28 1.1024	27.991 1.1020	34.988 1.3775	34.972 1.3769	34.972 1.3769	28.020 1.1031	28.043 1.1041	0.0606	JR22x28x20,5 28 1.1024	
0.030 0.066	30 1.1811	29.991 1.1807	36.988 1.4562	36.972 1.4556	36.972 1.4556	30.020 1.1819	30.043 1.1828	0.0567	JR25x30x17 30 1.1811	
0.042 0.093	30 1.1811	29.991 1.1807	36.988 1.4562	36.972 1.4556	36.972 1.4556	30.020 1.1819	30.043 1.1828	0.0640	JR25x30x20,5	
0.040 0.088	30 1.1811	29.991 1.1807	36.988 1.4562	36.972 1.4556	36.972 1.4556	30.020 1.1819	30.043 1.1828	0.0640	JR25x30x20,5	
0.051 0.112	30 1.1811	29.991 1.1807	36.988 1.4562	36.972 1.4556	36.972 1.4556	30.020 1.1819	30.043 1.1828	0.0702	JR25x30x26	
0.057 0.126	30 1.1811	29.991 1.1807	36.988 1.4562	36.972 1.4556	36.972 1.4556	30.020 1.1819	30.043 1.1828	0.0702	JR25x30x26	
0.047 0.104	35 1.3780	34.989 1.3775	41.988 1.6531	41.972 1.6524	41.972 1.6524	35.025 1.3789	35.052 1.3800	0.0646	JR30x35x17 35 1.3780	
0.054 1.119	35 1.3780	34.989 1.3775	41.988 1.6531	41.972 1.6524	41.972 1.6524	35.025 1.3789	35.052 1.3800	0.0701	JR30x35x20,5	
0.044 0.097	35 1.3780	34.989 1.3775	41.988 1.6531	41.972 1.6524	41.972 1.6524	35.025 1.3789	35.052 1.3800	0.0701	JR30x35x20,5	
0.037 0.082	40 1.5748	39.989 1.5744	46.988 1.8499	46.972 1.8493	46.972 1.8493	40.025 1.5758	40.052 1.5769	0.0693	JR35x40x20 40 1.5748	
0.057 0.126	40 1.5748	39.989 1.5744	46.988 1.8499	46.972 1.8493	46.972 1.8493	40.025 1.5758	40.052 1.5769	0.0773	JR35x40x20,5	
0.053 0.117	40 1.5748	39.989 1.5744	46.988 1.8499	46.972 1.8493	46.972 1.8493	40.025 1.5758	40.052 1.5769	0.0773	JR35x40x20,5	
0.064 0.141	45 1.7717	44.989 1.7712	51.986 2.0467	51.967 2.0459	51.967 2.0459	45.025 1.7726	45.052 1.7737	0.0836	JR40x45x20,5 45 1.7717	
0.055 0.121	45 1.7717	44.989 1.7712	51.986 2.0467	51.967 2.0459	51.967 2.0459	45.025 1.7726	45.052 1.7737	0.0836	JR40x45x20,5	
0.097 0.214	50 1.9685	49.989 1.9681	57.986 2.2829	57.967 2.2822	57.967 2.2822	50.025 1.9695	50.052 1.9706	0.0937	JR45x50x25,5 50 1.9685	
0.083 0.183	50 1.9685	49.989 1.9681	57.986 2.2829	57.967 2.2822	57.967 2.2822	50.025 1.9695	50.052 1.9706	0.0937	JR45x50x25,5	



INNER RINGS

METRIC SERIES

When it is impractical to meet the shaft raceway design requirements (hardness, surface finish, case depth, etc.) outlined in the engineering section of this catalog, standard inner rings may be used.

Inner rings are made of rolling bearing steel and after hardening, their bores, raceways and end surfaces are ground. Metric series inner rings may be used to provide inner raceway surfaces for metric series radial needle roller and cage assemblies, metric series needle roller bearings and metric series drawn cup needle roller bearings. The extended inner rings are suitable for use with bearings containing lip contact seals and for applications in which axial movement may be present.

CONSTRUCTION

Metric series inner rings are available in four basic designs and differ only by the chamfers at the ends of the raceway surfaces, the lubricant access holes and the raceway profile. Inner rings of series JR have chamfers to assist in bearing installation but are without lubricating holes. Inner rings of series JR and IM have bearing installation chamfers and lubricating holes (bore diameters 5 to 180 mm [0.1969 in to 7.0866 in]). Inner rings of series JRZ.JS1 are without installation chamfers, allowing for maximum possible raceway contact.

DIMENSIONAL ACCURACY

The tolerances of size, form, and runout for metric series inner rings meet the requirements of ISO normal tolerance class for radial bearings (see the engineering section). Most metric series inner rings are produced with outside diameter raceway tolerance in accordance with h5 which, in most cases, is suitable for combining the metric series needle roller bearings to give the normal clearance class, and for use with drawn cup bearings. Other raceway tolerances may also be found on inner rings for combining with needle roller bearings to give one of the clearance requirement.

MOUNTING OF INNER RINGS

Inner rings may be mounted on the shaft with either a loose transition fit or an interference fit. These fits used in conjunction with the proper fit of the bearing outer ring, will provide the correct operating clearances for most applications.

Regardless of the fit of the inner ring on the shaft, the inner ring should be axially located by shaft shoulders or other positive means. The shaft shoulder diameter adjacent to the inner ring must not exceed the inner ring outside diameter (per suggestions on pages B-151 and B-152 of the metric series needle roller bearing section).

When metric series inner rings are to be used with the metric series needle roller bearings, appropriate shaft tolerances should be selected from Table B-19 on page B-151 in the metric series needle roller bearing section. When Metric series inner rings are to be used with drawn cup bearings the suggested shaft tolerances are given in the "Inner ring" discussion on page B-46 of the "metric series drawn cup needle roller bearings" section of this catalog.

INCH SERIES INNER RINGS

Inch series inner rings for use with inch series drawn cup bearings are tabulated on page B-120 of this catalog.

INNER RINGS

METRIC SERIES

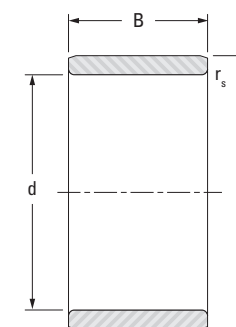

JR, IM..P

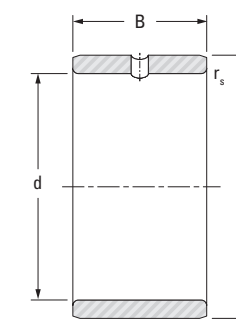

JR.JS1

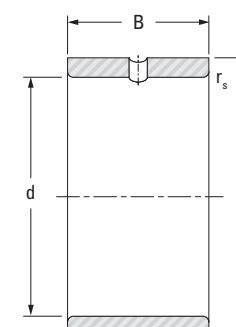

JRZ.JS1

Table with 7 columns: Shaft Dia. (mm/in), d (mm/in), F(1) (mm/in), B (mm/in), r_s min (mm/in), Inner Ring Designation, and Wt. (kg/lbs). Rows list various inner ring models like JR5x8x8JS1, JR5x8x12, JR5x8x16, JR6x9x8JS1, JR6x9x12, JR6x9x16, JR6x10x10, JR6x10x10JS1, JRZ6x10x12JS1, JR7x10x10,5, JR7x10x12, JR7x10x16, JR8x12x10, JR8x12x10JS1, JR8x12x10,5, JRZ8x12x12JS1, JR8x12x12,5, IM 8 12 16 P, JR9x12x12, JR9x12x16, JR10x13x12,5, JR10x14x11JS1, JR10x14x12, and JR10x14x12JS1.

(1) Inner rings for metric full complement needle roller bearings are produced with outside diameter tolerance g5.

Continued on next page.



INNER RINGS — continued

METRIC SERIES

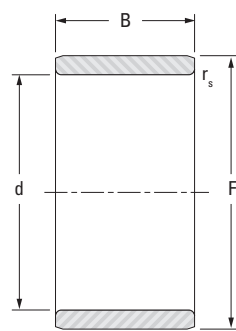

JR, IM..P

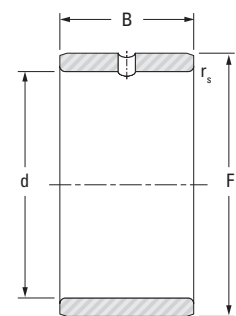

JR.JS1

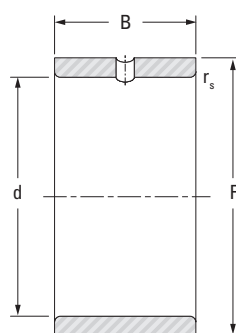

JRZ.JS1

Shaft Dia.	d	F ⁽¹⁾	B	r _s min	Inner Ring Designation	Wt.
mm in	mm in	mm in	mm in	mm in		kg lbs
10 0.3937	10 0.3937	14 0.5512	13 0.512	0.3 0.01	JR10x14x13	0.007 0.015
	10 0.3937	14 0.5512	14 0.551	0.3 0.01	JRZ10x14x14JS1	0.008 0.018
	10 0.3937	14 0.5512	16 0.630	0.3 0.01	JR10x14x16	0.009 0.020
	10 0.3937	14 0.5512	20 0.787	0.3 0.01	JR10x14x20	0.012 0.026
12 0.4724	12 0.4724	15 0.5906	12.5 0.492	0.3 0.01	JR12x15x12,5	0.006 0.013
	12 0.4724	15 0.5906	16 0.630	0.3 0.01	JR12x15x16	0.008 0.018
	12 0.4724	15 0.5906	16.5 0.650	0.3 0.01	JR12x15x16,5	0.008 0.018
	12 0.4724	15 0.5906	18.5 0.728	0.3 0.01	JR12x15x18,5	0.009 0.020
	12 0.4724	15 0.5906	22.4 0.882	0.2 0.01	IM 12 15 22,4 P	0.011 0.024
	12 0.4724	15 0.5906	22.5 0.886	0.3 0.01	JR12x15x22,5	0.011 0.024
	12 0.4724	16 0.6299	12 0.472	0.3 0.01	JR12x16x12	0.008 0.018
	12 0.4724	16 0.6299	12 0.472	0.3 0.01	JR12x16x12JS1	0.008 0.018
	12 0.4724	16 0.6299	13 0.512	0.3 0.01	JR12x16x13	0.008 0.018
	12 0.4724	16 0.6299	14 0.551	0.3 0.01	JRZ12x16x14JS1	0.010 0.022
	12 0.4724	16 0.6299	16 0.630	0.3 0.01	JR12x16x16	0.011 0.024
	12 0.4724	16 0.6299	20 0.787	0.3 0.01	JR12x16x20	0.014 0.031
	12 0.4724	16 0.6299	22 0.866	0.3 0.01	JR12x16x22	0.015 0.033
13 0.5118	13 0.5118	18 0.7087	16 0.630	0.35 0.014	IM 13 18 16 P	0.015 0.033
14 0.5512	14 0.5512	17 0.6693	17 0.669	0.3 0.01	JR14x17x17	0.009 0.020
15 0.5906	15 0.5906	18 0.7087	16.5 0.650	0.3 0.01	JR15x18x16,5	0.010 0.022
	15 0.5906	19 0.7480	16 0.630	0.3 0.01	JR15x19x16	0.013 0.029
	15 0.5906	19 0.7480	20 0.787	0.3 0.01	JR15x19x20	0.017 0.037
	15 0.5906	20 0.7874	12 0.472	0.3 0.01	JR15x20x12	0.012 0.026
	15 0.5906	20 0.7874	12 0.472	0.3 0.01	JR15x20x12JS1	0.012 0.026

⁽¹⁾ Inner rings for metric full complement needle roller bearings are produced with outside diameter tolerance g5.

Continued on next page.

INNER RINGS — continued

METRIC SERIES

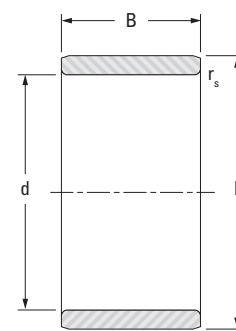

JR, IM..P

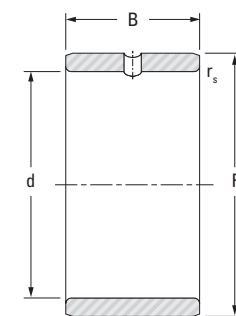

JR.JS1

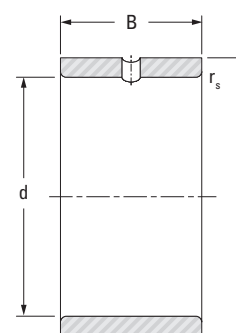

JRZ.JS1

Shaft Dia.	d	F ⁽¹⁾	B	r _s min	Inner Ring Designation	Wt.
mm in	mm in	mm in	mm in	mm in		kg lbs
15 0.5906	15 0.5906	20 0.7874	13 0.512	0.3 0.01	JR15x20x13	0.014 0.031
	15 0.5906	20 0.7874	14 0.551	0.3 0.01	JRZ15x20x14JS1	0.015 0.033
	15 0.5906	20 0.7874	16 0.630	0.3 0.01	JR15x20x16	0.017 0.037
	15 0.5906	20 0.7874	20 0.787	0.35 0.014	IM 15 20 20 P	0.021 0.045
	15 0.5906	20 0.7874	23 0.906	0.3 0.01	JR15x20x23	0.025 0.055
	15 0.5906	20 0.7874	26 1.024	0.3 0.01	JR15x20x26	0.028 0.062
17 0.6693	17 0.6693	20 0.7874	16.5 0.650	0.3 0.01	JR17x20x16,5	0.011 0.024
	17 0.6693	20 0.7874	20 0.787	0.3 0.01	JR17x20x20	0.014 0.031
	17 0.6693	20 0.7874	20.5 0.807	0.3 0.01	JR17x20x20,5	0.014 0.031
	17 0.6693	20 0.7874	30.5 1.201	0.3 0.01	JR17x20x30,5	0.021 0.046
	17 0.6693	21 0.8268	16 0.630	0.3 0.01	JR17x21x16	0.015 0.033
	17 0.6693	21 0.8268	20 0.787	0.3 0.01	JR17x21x20	0.019 0.042
	17 0.6693	22 0.8661	13 0.512	0.3 0.01	JR17x22x13	0.015 0.033
	17 0.6693	22 0.8661	13 0.512	0.35 0.014	IM 4903	0.015 0.033
	17 0.6693	22 0.8661	16 0.630	0.3 0.01	JR17x22x16	0.019 0.042
	17 0.6693	22 0.8661	16 0.630	0.3 0.01	JR17x22x16JS1	0.019 0.042
	17 0.6693	22 0.8661	16 0.630	0.3 0.01	JRZ17x22x16JS1	0.019 0.042
	17 0.6693	22 0.8661	20 0.787	0.35 0.014	IM 17 22 20 P	0.023 0.051
	17 0.6693	22 0.8661	23 0.906	0.3 0.01	JR17x22x23	0.028 0.062
	17 0.6693	22 0.8661	26 1.024	0.3 0.01	JR17x22x26	0.031 0.068
	17 0.6693	22 0.8661	32 1.260	0.3 0.01	JR17x22x32	0.038 0.084
20 0.7874	20 0.7874	24 0.9449	16 0.630	0.3 0.01	JR20x24x16	0.018 0.040
	20 0.7874	24 0.9449	20 0.787	0.3 0.01	JR20x24x20	0.022 0.049
	20 0.7874	25 0.9843	16 0.630	0.3 0.01	JR20x25x16	0.022 0.049

⁽¹⁾ Inner rings for metric full complement needle roller bearings are produced with outside diameter tolerance g5.

Continued on next page.



INNER RINGS – continued

METRIC SERIES

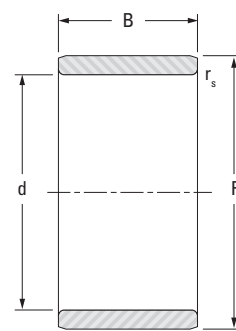

JR, IM..P

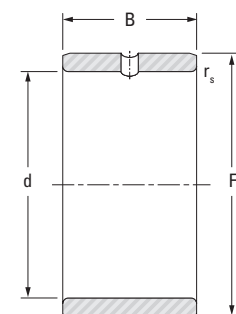

JR.JS1

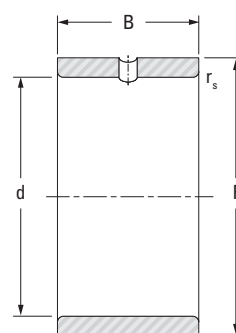

JRZ.JS1

Shaft Dia.	d	F ⁽¹⁾	B	r _s min	Inner Ring Designation	Wt.
mm in	mm in	mm in	mm in	mm in		kg lbs
20 0.7874	20 0.7874	25 0.9843	16 0.630	0.3 0.01	JR20x25x16JS1	0.022 0.049
	20 0.7874	25 0.9843	17 0.669	0.3 0.01	JR20x25x17	0.023 0.051
	20 0.7874	25 0.9843	18 0.709	0.3 0.01	JRZ20x25x18JS1	0.025 0.055
	20 0.7874	25 0.9843	20 0.787	0.3 0.01	JR20x25x20	0.028 0.062
	20 0.7874	25 0.9843	20.5 0.807	0.3 0.01	JR20x25x20,5	0.029 0.064
	20 0.7874	25 0.9843	26 1.024	0.3 0.01	JR20x25x26	0.036 0.079
	20 0.7874	25 0.9843	26.5 1.043	0.3 0.01	JR20x25x26,5	0.037 0.082
	20 0.7874	25 0.9843	30 1.181	0.3 0.01	JR20x25x30	0.042 0.093
	20 0.7874	25 0.9843	32 1.260	0.3 0.01	JR20x25x32	0.044 0.097
	20 0.7874	25 0.9843	38.5 1.516	0.3 0.01	JR20x25x38,5	0.054 0.119
22 0.8661	22 0.8661	26 1.0236	16 0.630	0.3 0.01	JR22x26x16	0.019 0.042
	22 0.8661	26 1.0236	20 0.787	0.3 0.01	JR22x26x20	0.023 0.051
	22 0.8661	28 1.1024	17 0.669	0.3 0.01	JR22x28x17	0.030 0.066
	22 0.8661	28 1.1024	20.5 0.807	0.3 0.01	JR22x28x20,5	0.038 0.084
	22 0.8661	28 1.1024	30 1.181	0.3 0.01	JR22x28x30	0.056 0.123
23 0.9055	23 0.9055	28 1.1024	20 0.787	0.35 0.014	IM 23 28 20 P	0.030 0.066
	25 0.9843	29 1.1417	20 0.787	0.3 0.01	JR25x29x20	0.027 0.060
	25 0.9843	29 1.1417	30 1.181	0.3 0.01	JR25x29x30	0.040 0.088
	25 0.9843	30 1.1811	16 0.630	0.3 0.01	JR25x30x16	0.027 0.060
	25 0.9843	30 1.1811	16 0.630	0.3 0.01	JR25x30x16JS1	0.027 0.060
	25 0.9843	30 1.1811	17 0.669	0.3 0.01	JR25x30x17	0.028 0.062
	25 0.9843	30 1.1811	18 0.709	0.3 0.01	JRZ25x30x18JS1	0.031 0.068
	25 0.9843	30 1.1811	20 0.787	0.3 0.01	JR25x30x20	0.034 0.075
	25 0.9843	30 1.1811	20.5 0.807	0.3 0.01	JR25x30x20,5	0.035 0.077

⁽¹⁾ Inner rings for metric full complement needle roller bearings are produced with outside diameter tolerance g5.

Continued on next page.

INNER RINGS – continued

METRIC SERIES

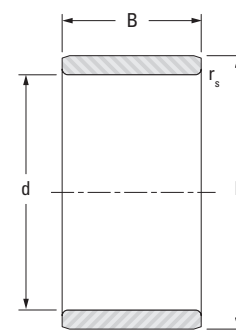

JR, IM..P

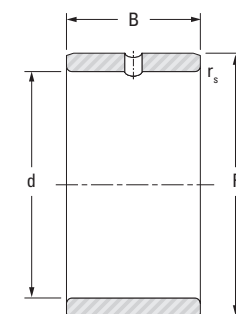

JR.JS1

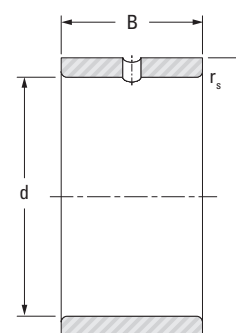

JRZ.JS1

Shaft Dia.	d	F ⁽¹⁾	B	r _s min	Inner Ring Designation	Wt.
mm in	mm in	mm in	mm in	mm in		kg lbs
25 0.9843	25 0.9843	30 1.1811	26 1.024	0.3 0.01	JR25x30x26	0.044 0.097
	25 0.9843	30 1.1811	26.5 1.043	0.3 0.01	JR25x30x26,5	0.045 0.099
	25 0.9843	30 1.1811	30 1.181	0.3 0.01	JR25x30x30	0.051 0.112
	25 0.9843	30 1.1811	32 1.260	0.3 0.01	JR25x30x32	0.054 0.119
	25 0.9843	30 1.1811	38.5 1.516	0.3 0.01	JR25x30x38,5	0.066 0.146
28 1.1024	28 1.1024	32 1.2598	17 0.669	0.3 0.01	JR28x32x17	0.028 0.062
	28 1.1024	32 1.2598	20 0.787	0.3 0.01	JR28x32x20	0.030 0.066
	28 1.1024	32 1.2598	30 1.181	0.3 0.01	JR28x32x30	0.044 0.097
30 1.1811	30 1.1811	35 1.3780	16 0.630	0.3 0.01	JR30x35x16	0.031 0.068
	30 1.1811	35 1.3780	17 0.669	0.3 0.01	JR30x35x17	0.033 0.073
	30 1.1811	35 1.3780	17 0.669	0.35 0.014	IM 4906	0.033 0.073
	30 1.1811	35 1.3780	18 0.709	0.3 0.01	JR30x35x18JS1	0.036 0.079
	30 1.1811	35 1.3780	20 0.787	0.3 0.01	JR30x35x20	0.039 0.086
	30 1.1811	35 1.3780	20 0.787	0.3 0.01	JRZ30x35x20JS1	0.039 0.086
	30 1.1811	35 1.3780	20.5 0.807	0.3 0.01	JR30x35x20,5	0.040 0.088
	30 1.1811	35 1.3780	26 1.024	0.3 0.01	JR30x35x26	0.054 0.119
	30 1.1811	35 1.3780	30 1.181	0.3 0.01	JR30x35x30	0.057 0.126
	30 1.1811	35 1.3780	32 1.260	0.3 0.01	JR30x35x32	0.062 0.137
	30 1.1811	38 1.4961	20 0.787	0.6 0.02	JR30x38x20JS1	0.067 0.148
32 1.2598	32 1.2598	37 1.4567	20 0.787	0.3 0.01	JR32x37x20	0.043 0.095
	32 1.2598	37 1.4567	30 1.181	0.3 0.01	JR32x37x30	0.064 0.141
	32 1.2598	40 1.5748	20 0.787	0.6 0.02	JR32x40x20	0.069 0.152
	32 1.2598	40 1.5748	36 1.417	0.6 0.02	JR32x40x36	0.128 0.282
35 1.3780	35 1.3780	40 1.5748	17 0.669	0.3 0.01	JR35x40x17	0.040 0.088

⁽¹⁾ Inner rings for metric full complement needle roller bearings are produced with outside diameter tolerance g5.

Continued on next page.



INNER RINGS – continued

METRIC SERIES

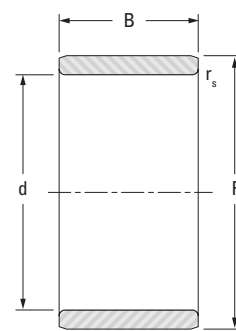

JR, IM..P

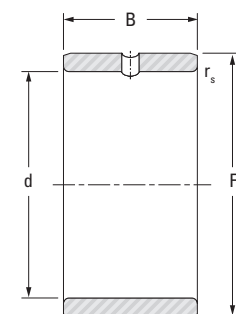

JR.JS1

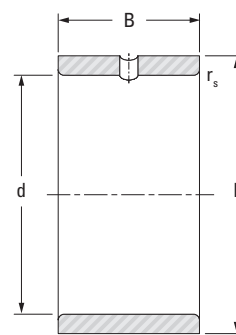

JRZ.JS1

Shaft Dia.	d	F ⁽¹⁾	B	r _s min	Inner Ring Designation	Wt.
mm in	mm in	mm in	mm in	mm in		kg lbs
35 1.3780	35 1.3780	40 1.5748	20 0.787	0.3 0.01	JR35x40x20	0.046 0.101
	35 1.3780	40 1.5748	20.5 0.807	0.3 0.01	JR35x40x20,5	0.049 0.108
	35 1.3780	40 1.5748	22 0.866	0.3 0.01	JR35x40x22	0.052 0.115
	35 1.3780	40 1.5748	30 1.181	0.3 0.01	JR35x40x30	0.071 0.157
	35 1.3780	40 1.5748	34 1.339	0.3 0.01	JR35x40x34	0.080 0.176
	35 1.3780	40 1.5748	40 1.575	0.3 0.01	JR35x40x40	0.094 0.207
	35 1.3780	42 1.6535	20 0.787	0.6 0.02	JR35x42x20	0.065 0.143
	35 1.3780	42 1.6535	20 0.787	0.6 0.02	JR35x42x20JS1	0.065 0.143
	35 1.3780	42 1.6535	23 0.906	0.6 0.02	JRZ35x42x23JS1	0.074 0.163
	35 1.3780	42 1.6535	36 1.417	0.6 0.02	JR35x42x36	0.122 0.269
	35 1.3780	44 1.7323	22 0.866	0.6 0.02	JR35x44x22	0.097 0.214
37 1.4567	37 1.4567	42 1.6535	20 0.787	0.35 0.014	IM 37 42 20 P	0.046 0.101
	38 1.4961	43 1.6929	20 0.787	0.3 0.01	JR38x43x20	0.050 0.110
	38 1.4961	43 1.6929	30 1.181	0.3 0.01	JR38x43x30	0.075 0.165
	40 1.5748	45 1.7717	17 0.669	0.3 0.01	JR40x45x17	0.044 0.097
	40 1.5748	45 1.7717	20 0.787	0.3 0.01	JR40x45x20	0.052 0.115
	40 1.5748	45 1.7717	20.5 0.807	0.3 0.01	JR40x45x20,5	0.054 0.119
	40 1.5748	45 1.7717	25 0.984	0.35 0.014	IM 40 45 25 P	0.062 0.137
	40 1.5748	45 1.7717	30 1.181	0.3 0.01	JR40x45x30	0.078 0.172
	40 1.5748	45 1.7717	34 1.339	0.3 0.01	JR40x45x34	0.089 0.196
	40 1.5748	45 1.7717	40 1.575	0.3 0.01	JR40x45x40	0.115 0.254
	40 1.5748	48 1.8898	22 0.866	0.6 0.02	JR40x48x22	0.094 0.207
	40 1.5748	48 1.8898	23 0.906	0.6 0.02	JRZ40x48x23JS1	0.100 0.220
	40 1.5748	48 1.8898	40 1.575	0.6 0.02	JR40x48x40	0.173 0.381

⁽¹⁾ Inner rings for metric full complement needle roller bearings are produced with outside diameter tolerance g5.

Continued on next page.

INNER RINGS – continued

METRIC SERIES

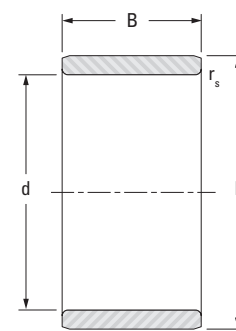

JR, IM..P

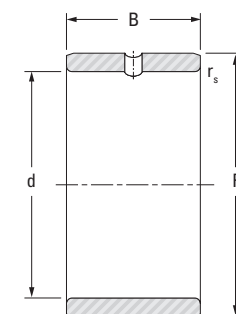

JR.JS1

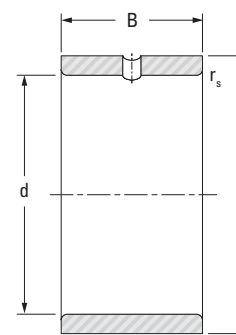

JRZ.JS1

Shaft Dia.	d	F ⁽¹⁾	B	r _s min	Inner Ring Designation	Wt.
mm in	mm in	mm in	mm in	mm in		kg lbs
40 1.5748	40 1.5748	50 1.9685	20 0.787	1 0.04	JR40x50x20	0.110 0.243
	42 1.6535	47 1.8504	20 0.787	0.3 0.01	JR42x47x20	0.055 0.121
	42 1.6535	47 1.8504	30 1.181	0.3 0.01	JR42x47x30	0.083 0.183
	45 1.7717	50 1.9685	20 0.787	0.3 0.01	JR45x50x20	0.058 0.128
	45 1.7717	50 1.9685	25 0.984	0.6 0.02	JR45x50x25	0.073 0.161
	45 1.7717	50 1.9685	25.5 1.004	0.3 0.01	JR45x50x25,5	0.075 0.165
	45 1.7717	50 1.9685	35 1.378	0.6 0.02	JR45x50x35	0.103 0.227
	45 1.7717	50 1.9685	40 1.575	0.3 0.01	JR45x50x40	0.117 0.258
	45 1.7717	52 2.0472	22 0.866	0.6 0.02	JR45x52x22	0.090 0.198
	45 1.7717	52 2.0472	22 0.866	0.85 0.033	IM 4909	0.087 0.192
	45 1.7717	52 2.0472	23 0.906	0.6 0.02	JR45x52x23	0.096 0.212
	45 1.7717	52 2.0472	23 0.906	0.6 0.02	JRZ45x52x23JS1	0.096 0.212
	45 1.7717	52 2.0472	40 1.575	0.6 0.02	JR45x52x40	0.167 0.368
	45 1.7717	55 2.1654	20 0.787	1 0.04	JR45x55x20	0.133 0.293
	45 1.7717	55 2.1654	20 0.787	1 0.04	JR45x55x20JS1	0.133 0.293
	45 1.7717	55 2.1654	22 0.866	1 0.04	JR45x55x22	0.135 0.298
	45 1.7717	55 2.1654	40 1.575	1 0.04	JR45x55x40	0.247 0.545
50 1.9685	50 1.9685	55 2.1654	20 0.787	0.3 0.01	JR50x55x20	0.065 0.143
	50 1.9685	55 2.1654	25 0.984	0.6 0.02	JR50x55x25	0.081 0.179
	50 1.9685	55 2.1654	35 1.378	0.65 0.026	IM 50 55 35 P	0.107 0.236
	50 1.9685	55 2.1654	35 1.378	0.6 0.02	JR50x55x35	0.113 0.249
	50 1.9685	55 2.1654	40 1.575	0.3 0.01	JR50x55x40	0.130 0.287
	50 1.9685	58 2.2835	22 0.866	0.6 0.02	JR50x58x22	0.117 0.258
	50 1.9685	58 2.2835	23 0.906	0.6 0.02	JRZ50x58x23JS1	0.122 0.269

⁽¹⁾ Inner rings for metric full complement needle roller bearings are produced with outside diameter tolerance g5.

Continued on next page.



INNER RINGS – continued

METRIC SERIES

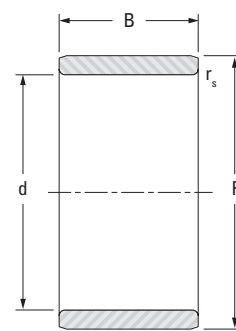

JR, IM..P

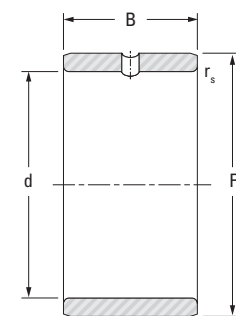

JR, JS1

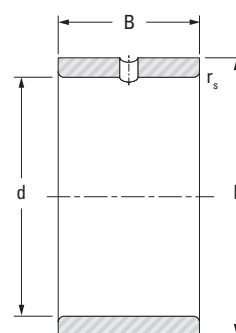

JRZ, JS1

Shaft Dia.	d	F ⁽¹⁾	B	r _s min	Inner Ring Designation	Wt.
mm in	mm in	mm in	mm in	mm in		kg lbs
50 1.9685	50 1.9685	58 2.2835	40 1.575	0.6 0.02	JR50x58x40	0.213 0.470
	50 1.9685	60 2.3622	20 0.787	1 0.04	JR50x60x20	0.155 0.342
	50 1.9685	60 2.3622	20 0.787	1 0.04	JR50x60x20JS1	0.155 0.342
	50 1.9685	60 2.3622	25 0.984	1 0.04	JR50x60x25	0.170 0.375
55 2.1654	50 1.9685	60 2.3622	40 1.575	1 0.04	JR50x60x40	0.310 0.683
	55 2.1654	60 2.3622	25 0.984	0.6 0.02	JR55x60x25	0.088 0.194
	55 2.1654	60 2.3622	35 1.378	0.65 0.026	IM 55 60 35 P	0.118 0.260
	55 2.1654	60 2.3622	35 1.378	0.6 0.02	JR55x60x35	0.124 0.273
55 2.1654	55 2.1654	63 2.4803	25 0.984	1 0.04	JR55x63x25	0.141 0.311
	55 2.1654	63 2.4803	45 1.772	1 0.04	JR55x63x45	0.286 0.631
	55 2.1654	65 2.5591	30 1.181	1 0.04	JR55x65x30	0.222 0.489
	55 2.1654	65 2.5591	60 2.362	1 0.04	JR55x65x60	0.444 0.979
58 2.2835	58 2.2835	65 2.5591	25 0.984	0.85 0.033	IM 58 65 25 P	0.125 0.276
	60 2.3622	60 2.3622	68 2.6772	25 0.984	0.6 0.02	JR60x68x25
60 2.3622		68 2.6772	35 1.378	0.6 0.02	JR60x68x35	0.220 0.485
60 2.3622		68 2.6772	45 1.772	1 0.04	JR60x68x45	0.284 0.626
60 2.3622		70 2.7559	25 0.984	1 0.04	JR60x70x25	0.200 0.441
60 2.3622	60 2.3622	70 2.7559	30 1.181	1 0.04	JR60x70x30	0.240 0.529
	60 2.3622	70 2.7559	35 1.378	0.85 0.033	IM 60 70 35 P	0.280 0.616
60 2.3622	60 2.3622	70 2.7559	60 2.362	1 0.04	JR60x70x60	0.480 1.058
	65 2.5591	65 2.5591	72 2.8346	25 0.984	1 0.04	JR65x72x25
65 2.5591		72 2.8346	45 1.772	1 0.04	JR65x72x45	0.266 0.586
65 2.5591	65 2.5591	73 2.8740	25 0.984	0.6 0.02	JR65x73x25	0.170 0.375
	65 2.5591	73 2.8740	35 1.378	0.6 0.02	JR65x73x35	0.240 0.529

⁽¹⁾ Inner rings for metric full complement needle roller bearings are produced with outside diameter tolerance g5.

Continued on next page.

INNER RINGS – continued

METRIC SERIES

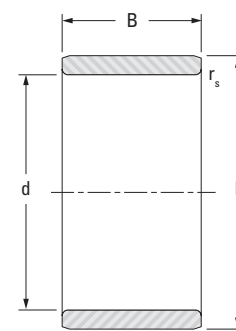

JR, IM..P

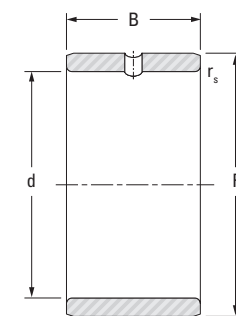

JR, JS1

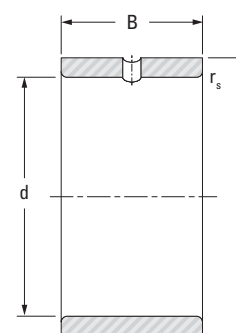

JRZ, JS1

Shaft Dia.	d	F ⁽¹⁾	B	r _s min	Inner Ring Designation	Wt.	
mm in	mm in	mm in	mm in	mm in		kg lbs	
65 2.5591	65 2.5591	75 2.9528	28 1.102	1 0.04	JR65x75x28	0.240 0.529	
	65 2.5591	75 2.9528	30 1.181	1 0.04	JR65x75x30	0.260 0.573	
65 2.5591	65 2.5591	75 2.9528	60 2.362	1 0.04	JR65x75x60	0.520 1.146	
	70 2.7559	70 2.7559	80 3.1496	25 0.984	1 0.04	JR70x80x25	0.230 0.507
70 2.7559		80 3.1496	30 1.181	1 0.04	JR70x80x30	0.270 0.595	
70 2.7559	70 2.7559	80 3.1496	35 1.378	1 0.04	JR70x80x35	0.320 0.705	
	70 2.7559	80 3.1496	54 2.126	1 0.04	JR70x80x54	0.500 1.102	
	70 2.7559	80 3.1496	60 2.362	1 0.04	JR70x80x60	0.556 1.226	
	75 2.9528	75 2.9528	85 3.3465	25 0.984	1 0.04	JR75x85x25	0.240 0.529
75 2.9528		85 3.3465	30 1.181	1 0.04	JR75x85x30	0.289 0.637	
75 2.9528	75 2.9528	85 3.3465	35 1.378	1 0.04	JR75x85x35	0.338 0.745	
	75 2.9528	85 3.3465	54 2.126	1 0.04	JR75x85x54	0.530 1.168	
	80 3.1496	80 3.1496	90 3.5433	25 0.984	1 0.04	JR80x90x25	0.260 0.573
		80 3.1496	90 3.5433	30 1.181	1 0.04	JR80x90x30	0.306 0.675
80 3.1496	80 3.1496	90 3.5433	35 1.378	1 0.04	JR80x90x35	0.355 0.783	
	80 3.1496	90 3.5433	54 2.126	1 0.04	JR80x90x54	0.565 1.246	
85 3.3465	85 3.3465	95 3.7402	26 1.024	1 0.04	JR85x95x26	0.290 0.639	
	85 3.3465	95 3.7402	30 1.181	1 0.04	JR85x95x30	0.334 0.736	
85 3.3465	85 3.3465	95 3.7402	36 1.417	1 0.04	JR85x95x36	0.397 0.875	
	85 3.3465	100 3.9370	35 1.378	1.1 0.04	JR85x100x35	0.595 1.312	
85 3.3465	85 3.3465	100 3.9370	63 2.480	1.1 0.04	JR85x100x63	1.080 2.381	
	90 3.5433	90 3.5433	100 3.9370	26 1.024	1 0.04	JR90x100x26	0.300 0.661
90 3.5433		100 3.9370	30 1.181	1 0.04	JR90x100x30	0.350 0.772	
90 3.5433	100 3.9370	36 1.417	1 0.04	JR90x100x36	0.422 0.930		

⁽¹⁾ Inner rings for metric full complement needle roller bearings are produced with outside diameter tolerance g5.

Continued on next page.



INNER RINGS — continued

METRIC SERIES

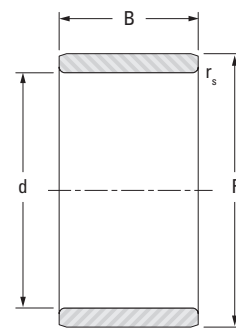

JR, IM..P

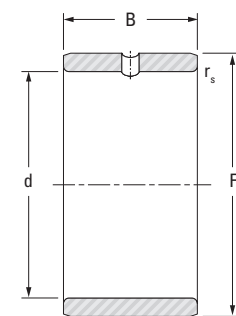

JR.JS1

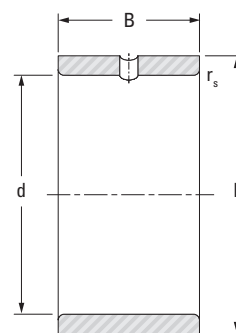

JRZ.JS1

Shaft Dia.	d	F ⁽¹⁾	B	r _s min	Inner Ring Designation	Wt.
mm in	mm in	mm in	mm in	mm in		kg lbs
90 3.5433	90 3.5433	105 4.1339	32 1.260	1.1 0.04	JR90x105x32	0.580 1.279
90 3.5433	90 3.5433	105 4.1339	35 1.378	1.1 0.04	JR90x105x35	0.624 1.376
	90 3.5433	105 4.1339	63 2.480	1.1 0.04	JR90x105x63	1.140 2.513
95 3.7402	95 3.7402	105 4.1339	26 1.024	1 0.04	JR95x105x26	0.310 0.683
	95 3.7402	105 4.1339	36 1.417	1 0.04	JR95x105x36	0.430 0.948
	95 3.7402	110 4.3307	35 1.378	1.1 0.04	JR95x110x35	0.653 1.440
	95 3.7402	110 4.3307	63 2.480	1.1 0.04	JR95x110x63	1.200 2.646
100 3.9370	100 3.9370	110 4.3307	30 1.181	1.1 0.04	JR100x110x30	0.384 0.847
	100 3.9370	110 4.3307	40 1.575	1.1 0.04	JR100x110x40	0.510 1.124
	100 3.9370	115 4.5276	40 1.575	1.1 0.04	JR100x115x40	0.790 1.742
110 4.3307	110 4.3307	120 4.7244	30 1.181	1 0.04	JR110x120x30	0.425 0.937
	110 4.3307	125 4.9213	40 1.575	1.1 0.04	JR110x125x40	0.870 1.918
120 4.7244	120 4.7244	130 5.1181	30 1.181	1 0.04	JR120x130x30	0.460 1.014
	120 4.7244	135 5.3150	45 1.772	1.1 0.04	JR120x135x45	1.060 2.337
130 5.1181	130 5.1181	145 5.7087	35 1.378	1.1 0.04	JR130x145x35	0.890 1.962
	130 5.1181	150 5.9055	50 1.969	1.5 0.06	JR130x150x50	1.730 3.814
140 5.5118	140 5.5118	155 6.1024	35 1.378	1.1 0.04	JR140x155x35	0.955 2.105
	140 5.5118	160 6.2992	50 1.969	1.5 0.06	JR140x160x50	1.860 4.101
150 5.9055	150 5.9055	165 6.4961	40 1.575	1.1 0.04	JR150x165x40	1.170 2.579
160 6.2992	160 6.2992	175 6.8898	40 1.575	1.1 0.04	JR160x175x40	1.240 2.734
170 6.6929	170 6.6929	185 7.2835	45 1.772	1.1 0.04	JR170x185x45	1.480 3.263
180 7.0866	180 7.0866	195 7.6772	45 1.772	1.1 0.04	JR180x195x45	1.560 3.439

⁽¹⁾ Inner rings for metric full complement needle roller bearings are produced with outside diameter tolerance g5.

NOTES



NEEDLE ROLLER BEARINGS

**FULL
COMPLEMENT
OPEN ENDS,
CLOSED ONE END
METRIC SERIES**

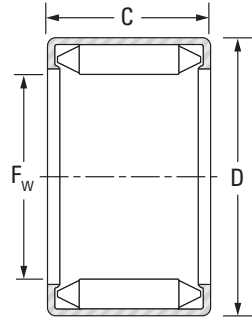

DL

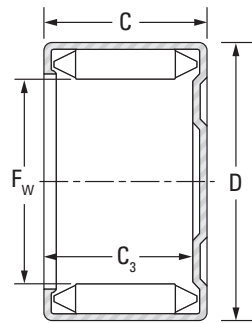

DLF

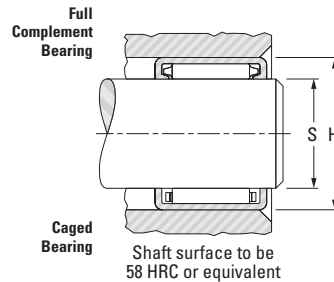

Shaft surface to be 58 HRC or equivalent

See Engineering section for discussion of shaft and housing design.

Shaft Dia.	F _w	D	C	C _{3 min}	Bearing Designation	Load Ratings		Speed Rating		C _g
						Dynamic	Static	Grease	Oil	
						C	C ₀			
6 0.2362	6 0.2362	12 0.4724	10 0.394	-	DL 6 10	2.90 650	3.80 850	33000	50000	0.0120
	6 0.2362	12 0.4724	10 0.394	7.7 0.303	DLF 6 10	2.90 650	3.80 850	33000	50000	0.0120
8 0.3150	8 0.3150	14 0.5512	10 0.394	-	DL 8 10	4.50 1010	6.50 1460	24000	37500	0.0145
	8 0.3150	14 0.5512	10 0.394	7.7 0.303	DLF 8 10	4.50 1010	6.50 1460	24000	37500	0.0145
9 0.3543	9 0.3543	14 0.5512	12 0.472	-	DL 9 14 12	6.10 1370	9.20 1270	21000	33000	0.0176
	9 0.3547	14 0.5512	12 0.472	9.70 0.382	DLF 9 14 12	6.10 1370	9.20 1270	21000	33000	0.0176
10 0.3937	10 0.3937	16 0.6299	12 0.472	-	DL 10 12	7.00 1570	10.9 2450	20000	30000	0.0180
	10 0.3937	16 0.6299	12 0.472	9.7 0.382	DLF 10 12	7.00 1570	10.9 2450	20000	30000	0.0180
12 0.4724	12 0.4724	18 0.7087	10 0.394	-	DL 12 10	6.00 1350	9.70 2180	16000	25000	0.0195
	12 0.4724	18 0.7087	10 0.394	7.70 0.303	DLF 12 10	6.00 1350	9.7 2180	16000	25000	0.0195
	12 0.4724	18 0.7087	12 0.472	-	DL 12 12	7.00 1570	11.5 2590	16000	25000	0.0206
	12 0.4724	18 0.7087	12 0.472	9.7 0.382	DLF 12 12	7.00 1570	11.5 2590	16000	25000	0.0206
13 0.5118	13 0.5118	19 0.7480	12 0.472	-	DL 13 12	8.50 1910	14.2 3190	15000	23000	0.0217
	13 0.5118	19 0.7480	12 0.472	9.7 0.382	DLF 13 12	8.50 1910	14.2 3190	15000	23000	0.0217
14 0.5512	14 0.5512	20 0.7874	12 0.472	-	DL 14 12	7.90 1780	13.5 3030	14000	21500	0.0229
	14 0.5512	20 0.7874	12 0.472	9.7 0.382	DLF 14 12	7.90 1780	13.5 3030	14000	21500	0.0229
15 0.5906	15 0.5906	21 0.8268	12 0.472	-	DL 15 12	9.40 2110	16.4 3690	13000	20000	0.0238
	15 0.5906	21 0.8268	12 0.472	9.7 0.382	DLF 15 12	9.40 2110	16.4 3690	13000	20000	0.0238
16 0.6299	16 0.6299	22 0.8661	12 0.472	-	DL 16 12	8.70 1960	15.5 3480	12000	18500	0.0251
	16 0.6299	22 0.8661	12 0.472	9.7 0.382	DLF 16 12	8.70 1960	15.5 3480	12000	18500	0.0251
17 0.6693	17 0.6693	23 0.9055	12 0.472	-	DL 17 12	9.00 2020	16.2 3640	11000	17500	0.0260
	17 0.6693	23 0.9055	12 0.472	9.7 0.382	DLF 17 12	9.00 2020	16.2 3640	11000	17500	0.0260
18 0.7087	18 0.7087	24 0.9449	12 0.472	-	DL 18 12	10.7 2410	19.5 4380	11000	16500	0.0272
	18 0.7087	24 0.9449	12 0.472	9.7 0.382	DLF 18 12	10.7 2410	19.5 4380	11000	16500	0.0272
	18 0.7087	24 0.9449	16 0.630	-	DL 18 16	16.0 3600	29.5 6630	11000	16500	0.0304
	18 0.7087	24 0.9449	16 0.630	13.7 0.539	DLF 18 16	16.0 3600	29.5 6630	11000	16500	0.0304

Drawn Cup Needle Roller Bearings

Wt.	S (h5)		H (H6)		Inspection		C _g	Mounting Inner Ring (pg B-82 to B-84)	Shaft Dia.	
	Recommended Mounting Dimension				Ring Gage	Plug Gage				
	Max.	Min.	Max.	Min.		Go				No Go
kg lbs	mm in	mm in	mm in	mm in					mm in	
0.004 0.009	6.000 0.2362	5.995 0.2360	12.011 0.4729	12.000 0.4724	12.000 0.4724	6.009 0.2366	6.036 0.2376		6 0.2362	
0.004 0.010	6.000 0.2362	5.995 0.2360	12.011 0.4729	12.000 0.4724	12.000 0.4724	6.009 0.2366	6.036 0.2376			
0.005 0.012	8.000 0.3150	7.994 0.3147	14.011 0.5516	14.000 0.5512	14.000 0.5512	8.009 0.3153	8.036 0.3164		8 0.3150	
0.006 0.013	8.000 0.3150	7.994 0.3147	14.011 0.5516	14.000 0.5512	14.000 0.5512	8.009 0.3153	8.036 0.3164			
0.006 0.013	9.000 0.3543	8.994 0.3541	14.011 0.5516	14.000 0.5512	14.000 0.5512	9.009 0.3547	9.036 0.3557		9 0.3543	
0.007 0.015	9.000 0.3543	8.994 0.3541	14.011 0.5516	14.000 0.5512	14.000 0.5512	9.009 0.3547	9.036 0.3557			
0.008 0.018	10.000 0.3937	9.994 0.3935	16.011 0.6304	16.000 0.6299	16.000 0.6299	10.009 0.3941	10.036 0.3951		10 0.3937	
0.009 0.020	10.000 0.3937	9.994 0.3935	16.011 0.6304	16.000 0.6299	16.000 0.6299	10.009 0.3941	10.036 0.3951			
0.008 0.017	12.000 0.4724	11.992 0.4721	18.011 0.7091	18.000 0.7087	18.000 0.7087	12.009 0.4728	12.035 0.4738		12 0.4724	
0.008 0.018	12.000 0.4724	11.992 0.4721	18.011 0.7091	18.000 0.7087	18.000 0.7087	12.009 0.4728	12.035 0.4738			
0.009 0.021	12.000 0.4724	11.992 0.4721	18.011 0.7091	18.000 0.7087	18.000 0.7087	12.009 0.4728	12.035 0.4738	0.0270	IM 8 12 12,4	
0.010 0.022	12.000 0.4724	11.992 0.4721	18.011 0.7091	18.000 0.7087	18.000 0.7087	12.009 0.4728	12.035 0.4738	0.0270	IM 8 12 12,4	
0.010 0.022	13.000 0.5118	12.992 0.5115	19.013 0.7485	19.000 0.7480	19.000 0.7480	13.009 0.5122	13.035 0.5132	0.0285	IM 9 13 12,4	
0.011 0.024	13.000 0.5118	12.992 0.5115	19.013 0.7485	19.000 0.7480	19.000 0.7480	13.009 0.5122	13.035 0.5132	0.0285	IM 9 13 12,4	
0.011 0.023	14.000 0.5512	13.992 0.5509	20.013 0.7879	20.000 0.7874	20.000 0.7874	14.009 0.5515	14.035 0.5526	0.0300	IM 10 14 12,4	
0.012 0.026	14.000 0.5512	13.992 0.5509	20.013 0.7879	20.000 0.7874	20.000 0.7874	14.009 0.5515	14.035 0.5526	0.0300	IM 10 14 12,4	
0.011 0.024	15.000 0.5906	14.992 0.5902	21.013 0.8273	21.000 0.8268	21.000 0.8268	15.009 0.5909	15.035 0.5919	0.0312	IM 12 15 12,4	
0.012 0.026	15.000 0.5906	14.992 0.5902	21.013 0.8273	21.000 0.8268	21.000 0.8268	15.009 0.5909	15.035 0.5919	0.0312	IM 12 15 12,4	
0.012 0.026	16.000 0.6299	15.992 0.6296	22.013 0.8667	22.000 0.8661	22.000 0.8661	16.009 0.6303	16.035 0.6313	0.0329	IM 12 16 12,4	
0.013 0.029	16.000 0.6299	15.992 0.6296	22.013 0.8667	22.000 0.8661	22.000 0.8661	16.009 0.6303	16.035 0.6313	0.0329	IM 12 16 12,4	
0.013 0.029	17.000 0.6693	16.992 0.6690	23.013 0.9060	23.000 0.9055	23.000 0.9055	17.009 0.6696	17.035 0.6707	0.0341	IM 13 17 12,4	
0.013 0.029	17.000 0.6693	16.992 0.6690	23.013 0.9060	23.000 0.9055	23.000 0.9055	17.009 0.6696	17.035 0.6707	0.0341	IM 13 17 12,4	
0.014 0.031	18.000 0.7087	17.992 0.7083	24.013 0.9454	24.000 0.9449	24.000 0.9449	18.009 0.7090	18.035 0.7100	0.0357	IM 13 18 12,4	
0.014 0.031	18.000 0.7087	17.992 0.7083	24.013 0.9454	24.000 0.9449	24.000 0.9449	18.009 0.7090	18.035 0.7100	0.0357	IM 13 18 12,4	
0.016 0.035	18.000 0.7087	17.992 0.7083	24.013 0.9454	24.000 0.9449	24.000 0.9449	18.009 0.7090	18.035 0.7100	0.0357	IM 13 18 12,4	
0.019 0.042	18.000 0.7087	17.992 0.7083	24.013 0.9454	24.000 0.9449	24.000 0.9449	18.009 0.7090	18.035 0.7100	0.0399	IM 13 18 16,4	
0.021 0.046	18.000 0.7087	17.992 0.7083	24.013 0.9454	24.000 0.9449	24.000 0.9449	18.009 0.7090	18.035 0.7100	0.0399	IM 13 18 16,4	

Continued on next page.



NEEDLE ROLLER BEARINGS

**FULL
COMPLEMENT
OPEN ENDS,
CLOSED ONE END**

— continued

METRIC SERIES

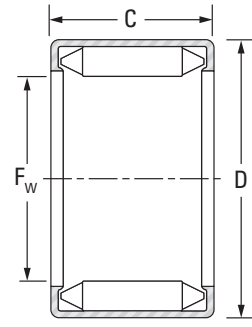

DL

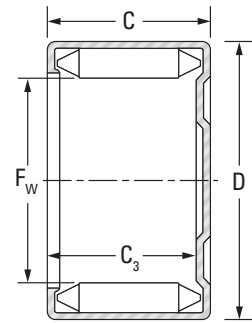

DLF

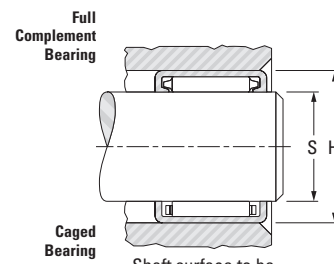

Shaft surface to be 58 HRC or equivalent

See Engineering section for discussion of shaft and housing design.

Shaft Dia. mm in	F _w mm in	D mm in	C mm in	C _{3 min} mm in	Bearing Designation	Load Ratings		Speed Rating		C _g
						Dynamic	Static	Grease	Oil	
						C	C ₀	min ⁻¹		
20 0.7874	20 0.7874	26 1.0236	12 0.472	—	DL 20 12	10.2 2290	19.5 4380	10000	15000	0.0292
	20 0.7874	26 1.0236	12 0.472	9.7 0.382	DLF 20 12	10.2 2290	19.5 4380	10000	15000	0.0292
	20 0.7874	26 1.0236	16 0.630	—	DL 20 16	16.0 3600	30.5 6860	10000	15000	0.0327
	20 0.7874	26 1.0236	16 0.630	13.7 0.539	DLF 20 16	16.0 3600	30.5 6860	10000	15000	0.0327
22 0.8661	22 0.8661	28 1.1024	16 0.630	—	DL 22 16	17.0 3820	33.0 7420	8800	13500	0.0349
	22 0.8661	28 1.1024	16 0.630	13.7 0.539	DLF 22 16	17.0 3820	33.0 7420	8800	13500	0.0349
25 0.9843	25 0.9843	33 1.2992	16 0.630	—	DL 25 16	16.0 3600	32.5 7310	7800	12000	0.0348
	25 0.9843	33 1.2992	16 0.630	13.7 0.539	DLF 25 16	16.0 3600	32.5 7310	7800	12000	0.0348
	25 0.9843	33 1.2992	20 0.787	—	DL 25 20	22.8 5130	46.0 10300	7800	12000	0.0379
	25 0.9843	33 1.2992	20 0.787	17.7 0.697	DLF 25 20	22.8 5130	46.0 10300	7800	12000	0.0379
28 1.1024	28 1.1024	36 1.4173	20 0.787	—	DL 28 20	24.5 5510	52.0 11700	7200	11000	0.0417
	28 1.1024	36 1.4173	20 0.787	17.70 0.697	DLF 28 20	24.5 5510	52.0 11700	7200	11000	0.0417
30 1.1811	30 1.1811	38 1.4961	16 0.630	—	DL 30 16	21.7 4880	46.5 10500	6500	10000	0.0403
	30 1.1811	38 1.4961	16 0.630	13.70 0.539	DLF 30 16	21.7 4880	46.5 10500	6500	10000	0.0403
	30 1.1811	38 1.4961	20 0.787	—	DL 30 20	26.0 5850	56.0 12600	6500	10000	0.0437
	30 1.1811	38 1.4961	20 0.787	17.70 0.697	DLF 30 20	26.0 5850	56.0 12600	6500	10000	0.0437
	30 1.1811	38 1.4961	25 0.984	—	DL 30 25	35.5 7980	76.0 17100	6500	10000	0.0470
	30 1.1811	38 1.4961	25 0.984	22.70 0.894	DLF 30 25	35.5 7980	76.0 17100	6500	10000	0.0470
35 1.3780	35 1.3780	43 1.6929	16 0.630	—	DL 35 16	24.0 5400	54.0 12100	5500	8500	0.0437
	35 1.3780	43 1.6929	16 0.630	13.70 0.539	DLF 35 16	24.0 5400	54.0 12100	5500	8500	0.0437
	35 1.3780	43 1.6929	20 0.787	—	DL 35 20	29.0 6520	65.0 14600	5500	8500	0.0477
	35 1.3780	43 1.6929	20 0.787	17.70 0.697	DLF 35 20	29.0 6520	65.0 14600	5500	8500	0.0477
40 1.5748	40 1.5748	48 1.8898	16 0.630	—	DL 40 16	26.5 5960	62.0 13900	4900	7500	0.0479
	40 1.5748	48 1.8898	16 0.630	13.70 0.539	DLF 40 16	26.5 5960	62.0 13900	4900	7500	0.0479
	40 1.5748	48 1.8898	20 0.787	—	DL 40 20	36.0 8090	84.0 18900	4900	7500	0.0523
	40 1.5748	48 1.8898	20 0.787	17.7 0.697	DLF 40 20	36.0 8090	84.0 18900	4900	7500	0.0523

Drawn Cup Needle Roller Bearings

Wt. kg lbs	S (h5)		H (H6)		Inspection		C _g	Mounting Inner Ring (pg B-82 to B-84)	Shaft Dia. mm in	
	Recommended Mounting Dimension				Ring Gage	Plug Gage				
	Max.	Min.	Max.	Min.	Go	No Go				
0.015 0.033	20.000 0.7874	19.991 0.7870	26.013 1.0241	26.000 1.0236	26.000 1.0236	20.009 0.7878	20.035 0.7888	0.0383	IM 15 20 12,4	20 0.7874
0.017 0.037	20.000 0.7874	19.991 0.7870	26.013 1.0241	26.000 1.0236	26.000 1.0236	20.009 0.7878	20.035 0.7888	0.0383	IM 15 20 12,4	
0.020 0.044	20.000 0.7874	19.991 0.7870	26.013 1.0241	26.000 1.0236	26.000 1.0236	20.009 0.7878	20.035 0.7888	0.0429	IM 15 20 16,4	
0.022 0.049	20.000 0.7874	19.991 0.7870	26.013 1.0241	26.000 1.0236	26.000 1.0236	20.009 0.7878	20.035 0.7888	0.0429	IM 15 20 16,4	
0.022 0.049	22.000 0.8661	21.991 0.8658	28.013 1.1029	28.000 1.1024	28.000 1.1024	20.009 0.7878	20.035 0.7888	0.0458	IM 17 22 16,4	22 0.8661
0.025 0.055	22.000 0.8661	21.991 0.8658	28.013 1.1029	28.000 1.1024	28.000 1.1024	20.009 0.7878	20.035 0.7888	0.0458	IM 17 22 16,4	
0.035 0.077	25.000 0.9843	24.991 0.9839	33.016 1.2998	33.000 1.2992	33.000 1.2992	22.009 0.8665	22.035 0.8675	0.0457	IM 20 25 16,4	25 0.9843
0.039 0.086	25.000 0.9843	24.991 0.9839	33.016 1.2998	33.000 1.2992	33.000 1.2992	22.009 0.8665	22.035 0.8675	0.0457	IM 20 25 16,4	
0.043 0.095	25.000 0.9843	24.991 0.9839	33.016 1.2998	33.000 1.2992	33.000 1.2992	25.015 0.9848	25.041 0.9859	0.0497	IM 20 25 20,4	
0.047 0.104	25.000 0.9843	24.991 0.9839	33.016 1.2998	33.000 1.2992	33.000 1.2992	25.015 0.9848	25.041 0.9859	0.0497	IM 20 25 20,4	
0.047 0.104	28.000 1.1024	27.991 1.1020	36.016 1.4180	36.000 1.4173	36.000 1.4173	28.015 1.1030	28.041 1.1040	0.0547	IM 23 28 20,4	28 1.1024
0.051 0.112	28.000 1.1024	27.991 1.1020	36.016 1.4180	36.000 1.4173	36.000 1.4173	28.015 1.1030	28.041 1.1040	0.0547	IM 23 28 20,4	
0.040 0.088	30.000 1.1811	29.991 1.1807	38.016 1.4967	38.000 1.4961	38.000 1.4961	30.015 1.1817	30.041 1.1827	0.0529	IM 25 30 16,4	30 1.1811
0.045 0.099	30.000 1.1811	29.991 1.1807	38.016 1.4967	38.000 1.4961	38.000 1.4961	30.015 1.1817	30.041 1.1827	0.0529	IM 25 30 16,4	
0.050 0.110	30.000 1.1811	29.991 1.1807	38.016 1.4967	38.000 1.4961	38.000 1.4961	30.015 1.1817	30.041 1.1827	0.0573	IM 25 30 20,4	
0.055 0.121	30.000 1.1811	29.991 1.1807	38.016 1.4967	38.000 1.4961	38.000 1.4961	30.015 1.1817	30.041 1.1827	0.0573	IM 25 30 20,4	
0.063 0.139	30.000 1.1811	29.991 1.1807	38.016 1.4967	38.000 1.4961	38.000 1.4961	30.015 1.1817	30.041 1.1827	0.0617	IM 25 30 25	
0.068 0.150	30.000 1.1811	29.991 1.1807	38.016 1.4967	38.000 1.4961	38.000 1.4961	30.015 1.1817	30.041 1.1827	0.0617	IM 25 30 25	
0.046 0.101	35.000 1.3780	34.989 1.3775	43.016 1.6935	43.000 1.6929	43.000 1.6929	35.015 1.3785	35.041 1.3796	0.0573	IM 30 35 16,4	35 1.3780
0.053 0.117	35.000 1.3780	34.989 1.3775	43.016 1.6935	43.000 1.6929	43.000 1.6929	35.015 1.3785	35.041 1.3796	0.0573	IM 30 35 16,4	
0.057 0.126	35.000 1.3780	34.989 1.3775	43.016 1.6935	43.000 1.6929	43.000 1.6929	35.015 1.3785	35.041 1.3796	0.0626	IM 30 35 20,4	
0.064 0.141	35.000 1.3780	34.989 1.3775	43.016 1.6935	43.000 1.6929	43.000 1.6929	35.015 1.3785	35.041 1.3796	0.0626	IM 30 35 20,4	
0.051 0.112	40.000 1.5748	39.989 1.5744	48.016 1.8904	48.000 1.8898	48.000 1.8898	40.015 1.5754	40.041 1.5764	0.0628	IM 35 40 16,4	40 1.5748
0.061 0.134	40.000 1.5748	39.989 1.5744	48.016 1.8904	48.000 1.8898	48.000 1.8898	40.015 1.5754	40.041 1.5764	0.0628	IM 35 40 16,4	
0.064 0.141	40.000 1.5748	39.989 1.5744	48.016 1.8904	48.000 1.8898	48.000 1.8898	40.015 1.5754	40.041 1.5764	0.0686	IM 35 40 20,4	
0.074 0.163	40.000 1.5748	39.989 1.5744	48.016 1.8904	48.000 1.8898	48.000 1.8898	40.015 1.5754	40.041 1.5764	0.0686	IM 35 40 20,4	

Continued on next page.



NEEDLE ROLLER BEARINGS

**FULL
COMPLEMENT
OPEN ENDS,
CLOSED ONE END**

— continued

METRIC SERIES

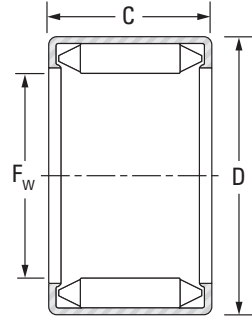

DL

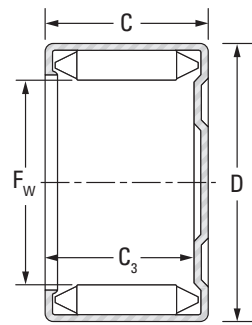

DLF

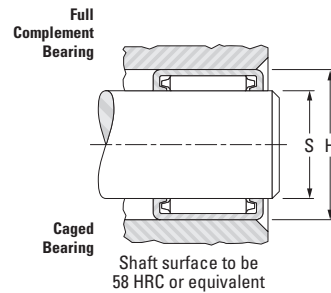

Shaft Dia. mm in	F _w mm in	D mm in	C mm in	C _{3 min} mm in	Bearing Designation	Load Ratings		Speed Rating		C _g
						Dynamic	Static	Grease	Oil	
						C	C ₀			
44 1.7323	44 1.7323	52 2.0472	16 0.630	—	DL 44 16	23.80 5350	57.00 12800	4400	6800	0.0512
	44 1.7323	52 2.0472	16 0.630	13.70 0.539	DLF 44 16	23.80 5350	57.00 12800	4400	6800	0.0512
47 1.8504	47 1.8504	55 2.1654	16 0.630	—	DL 47 16	25.00 5620	61.00 13700	4200	6400	0.0536
	47 1.8504	55 2.1654	16 0.630	13.70 0.539	DLF 47 16	25.00 5620	61.00 13700	4200	6400	0.0536
50 1.9685	50 1.9685	58 2.2835	12 0.472	—	DL 50 12	20.00 4500	50.00 11200	3900	6000	0.0508
	50 1.9685	58 2.2835	12 0.472	9.70 0.382	DLF 50 12	20.00 4500	50.00 11200	3900	6000	0.0508
	50 1.9685	58 2.2835	18 0.709	—	DL 50 18	36.50 8210	92.00 20700	3900	6000	0.0587
	50 1.9685	58 2.2835	18 0.709	15.70 0.618	DLF 50 18	36.50 8210	92.00 20700	3900	6000	0.0587
	50 1.9685	58 2.2835	20 0.787	—	DL 50 20	37.00 8320	93.00 20900	3900	6000	0.0611
	50 1.9685	58 2.2835	20 0.787	17.70 0.697	DLF 50 20	37.00 8320	93.00 20900	3900	6000	0.0611
55 2.1654	55 2.1654	63 2.4803	20 0.787	—	DL 55 20	39.5 8880	102.0 22900	3600	5500	0.0653
	55 2.1654	63 2.4803	20 0.787	17.70 0.697	DLF 55 20	39.5 8880	102.0 22900	3600	5500	0.0653

Drawn Cup Needle Roller Bearings

Wt. kg lbs	S (h5)		H (H6)		Inspection		C _g	Mounting Inner Ring (pg B-82 to B-84)	Shaft Dia. mm in	
	Recommended Mounting Dimension				Ring Gage	Plug Gage				
	Max.	Min.	Max.	Min.		Go				No Go
0.056 0.123	44.000 1.7323	43.989 1.7319	52.019 2.0480	52.000 2.0472	52.000 2.0472	44.015 1.7329	44.041 1.7339	0.0672	IM 40 44 16,4	44 1.7323
0.066 0.146	44.000 1.7323	43.989 1.7319	52.019 2.0480	52.000 2.0472	52.000 2.0472	44.015 1.7329	44.041 1.7339	0.0672	IM 40 44 16,4	
0.060 0.132	47.000 1.8504	46.989 1.8500	55.019 2.1661	55.000 2.1654	55.000 2.1654	47.015 1.8510	47.041 1.8520			47 1.8504
0.071 0.157	47.000 1.8504	46.989 1.8500	55.019 2.1661	55.000 2.1654	55.000 2.1654	47.015 1.8510	47.041 1.8520			
0.047 0.104	50.000 1.9685	49.989 1.9681	58.019 2.2842	58.000 2.2835	58.000 2.2835	50.015 1.9691	50.041 1.9701			50 1.9685
0.061 0.134	50.000 1.9685	49.989 1.9681	58.019 2.2842	58.000 2.2835	58.000 2.2835	50.015 1.9691	50.041 1.9701			
0.071 0.157	50.000 1.9685	49.989 1.9681	58.019 2.2842	58.000 2.2835	58.000 2.2835	50.015 1.9691	50.041 1.9701			
0.085 0.187	50.000 1.9685	49.989 1.9681	58.019 2.2842	58.000 2.2835	58.000 2.2835	50.015 1.9691	50.041 1.9701			
0.077 0.170	50.000 1.9685	49.989 1.9681	58.019 2.2842	58.000 2.2835	58.000 2.2835	50.015 1.9691	50.041 1.9701	0.0802	IM 45 50 20,4	
0.091 0.201	50.000 1.9685	49.989 1.9681	58.019 2.2842	58.000 2.2835	58.000 2.2835	50.015 1.9691	50.041 1.9701	0.0802	IM 45 50 20,4	
0.086 0.190	55.000 2.1654	54.987 2.1648	63.019 2.4811	63.000 2.4803	63.000 2.4803	55.015 2.1659	55.041 2.1670	0.0857	IM 50 55 20,4	55 2.1654
0.102 0.225	55.000 2.1654	54.987 2.1648	63.019 2.4811	63.000 2.4803	63.000 2.4803	55.015 2.1659	55.041 2.1670	0.0857	IM 50 55 20,4	

See Engineering section for discussion of shaft and housing design.



INNER RINGS FOR FULL COMPLEMENT DRAWN CUP NEEDLE ROLLER BEARINGS

METRIC SERIES

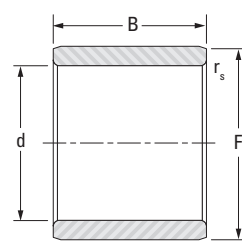

IM

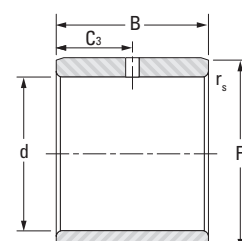

IMC

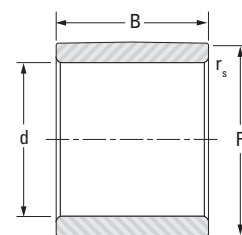

IM...R6

Table with 8 columns: Shaft Dia., d, F (1), B, Hole Location C3, r_s min, Inner Ring Designation, Wt. (kg/lbs). Rows include IM 8 12 12,4, IM 9 13 12,4, IM 9 13 12,4 R6, IM 10 14 12,4, IM 10 14 16,4, IM 11 15 12,4, IM 12 15 12,4, IM 12 16 12,4, IM 12 16 12,4 R6, IMC 12 16 12,4, IM 13 17 12,4, IM 13 18 12,4, IM 13 18 12,4 R6, IM 13 18 16,4, IM 15 20 12,4, IM 15 20 16,4, IM 17 22 16,4, IM 17 22 16,4 R6, IMC 17 22 16,4, IM 20 25 16,4, IM 20 25 16,4 R6, IMC 20 25 16,4, IM 20 25 20,4.

(1) Call for O.D. tolerance

Continued on next page.

INNER RINGS FOR FULL COMPLEMENT DRAWN CUP NEEDLE ROLLER BEARINGS - continued

METRIC SERIES

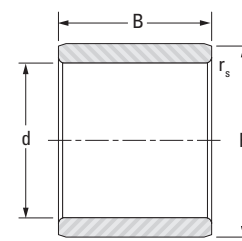

IM

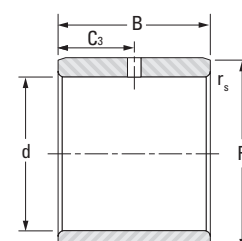

IMC

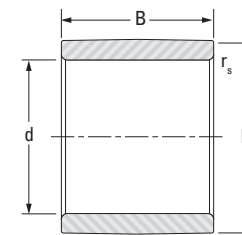

IM...R6

Table with 8 columns: Shaft Dia., d, F (1), B, Hole Location C3, r_s min, Inner Ring Designation, Wt. (kg/lbs). Rows include IMC 20 25 20,4, IM 20 25 25, IM 23 28 20,4, IM 25 30 16,4, IM 25 30 16,4 R6, IMC 25 30 16,4, IM 25 30 20,4, IMC 25 30 20,4, IM 25 30 25, IM 30 35 16,4, IM 30 35 16,4 R6, IMC 30 35 16,4, IM 30 35 20,4, IM 30 35 20,4 R6, IMC 30 35 20,4, IM 30 35 25, IM 35 40 16,4, IM 35 40 16,4 R6, IM 35 40 20,4, IM 35 40 20,4 R6, IMC 35 40 20,4, IM 35 40 25, IM 40 44 16,4.

(1) Call for O.D. tolerance

Continued on next page.



INNER RINGS FOR FULL COMPLEMENT DRAWN CUP NEEDLE ROLLER BEARINGS – continued

METRIC SERIES

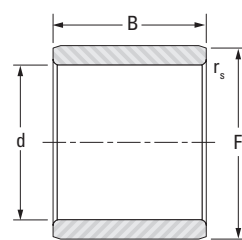

IM

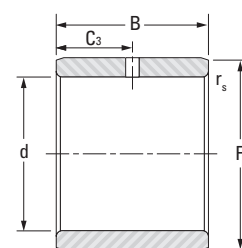

IMC

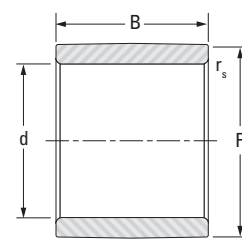

IM...R6

Shaft Dia.	d	F (1)	B	Hole Location C ₃	r _s min	Inner Ring Designation	Wt.
mm in	mm in	mm in	mm in	mm in	mm in		kg lbs
40 1.5748	40 1.5748	44 1.7323	16.4 0.646		0.3 0.01	IM 40 44 16,4 R6	0.032 0.071
	40 1.5748	44 1.7323	16.4 0.646	8.2 0.32	0.3 0.01	IMC 40 44 16,4	0.032 0.071
	40 1.5748	45 1.7717	20.4 0.803		0.35 0.014	IM 40 45 20,4	0.051 0.112
	40 1.5748	44 1.7323	20.4 0.803	10.2 0.40	0.35 0.014	IMC 40 45 20,4	0.051 0.112
45 1.7717	45 1.7717	50 1.9685	20.4 0.803		0.65 0.026	IM 45 50 20,4	0.056 0.123
	45 1.7717	50 1.9685	20.4 0.803		0.65 0.026	IM 45 50 20,4 R6	0.056 0.123
	45 1.7717	50 1.9685	25 0.984		0.65 0.026	IM 45 50 25	0.069 0.152
	45 1.7717	60 2.3622	25 0.984		0.65 0.026	IM 45 50 25 R6	0.069 0.152
50 1.9685	50 1.9685	55 2.1654	20.4 0.803		0.65 0.026	IM 50 55 20,4 R6	0.062 0.137
	50 1.9685	55 2.1654	20.4 0.803		0.65 0.026	IM 50 55 20,4	0.062 0.137

(1) Call for O.D. tolerance

DRAWN CUP NEEDLE ROLLER BEARINGS

INCH SERIES

When a rolling bearing is needed for a compact and economical design, where it is not practical to harden and grind the housing bore, or where the housing materials are of low rigidity such as cast iron, aluminum or even plastics – drawn cup needle roller bearings should be considered.

REFERENCE STANDARDS

- ANSI/ABMA 18.2 – needle roller bearings - radial, inch design.
- ASTM F2162 – standard specification for bearing, roller, needle: drawn outer ring, full complement, without inner ring, open and closed end, standard type.



Full complement bearings

Caged bearings

Fig. B-7. Types of inch series drawn cup needle roller bearings

IDENTIFICATION

The prefix letter, or letters in inch series drawn cup bearing designation, denote whether the bearings are made with a full complement of needle rollers or caged needle rollers. The use of a full complement of needle rollers is indicated by the prefix code letter **B**, and for use of caged needle rollers by the prefix code letter **J**.

Inch bearings are available in either of two radial cross sections. The larger cross section is indicated by the prefix code letter **H**. Absence of the letter **H** indicates the smaller radial cross section.

These major features of dimension and construction are summarized in Table B-9.

In addition, there can be other identifying letters which cover special modification. Please consult your representative when special modifications are required.

Because the entire identification code in the bearing designation may not appear on the bearing itself, the manufacturer's parts list (or another reliable source) should always be consulted when ordering bearings for service or field replacement.

Table B-9. Prefix letter in bearing designations

	Prefix letters in bearing designation	
	Smaller roller	Larger roller
Full complement (mechanically retained)	B	BH
Caged	J	JH



CONSTRUCTION

FULL COMPLEMENT BEARINGS

The original drawn cup needle roller bearing employs a full complement of needle rollers. The full complement drawn cup bearing combines maximum load-carrying capability with the advantages of the drawn outer ring.

The inward turned lips of the cup are used to mechanically retain the full complement of needle rollers, providing their positive radial retention – even though it may be necessary to remove the shaft repeatedly during servicing of the mechanism employing the bearing.

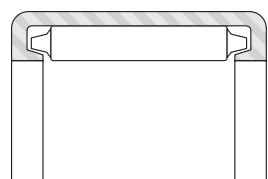

Fig. B-8. Full complement bearing

CAGED BEARINGS

The one-piece steel cage, used in most caged drawn cup bearings, is designed to provide rigidity and minimize wear. This cage design separates the roller guiding and roller retention functions. The portions of the cage that retain the rollers cannot contact the rollers while the bearing is operating. Thus, there is no wear which might affect roller retention.

The cage contacts the rollers only near their ends at the roller pitch line, so accurate guidance is achieved with least effort. Pitch line guidance at the ends of the rollers prevents skewing and assures roller stability, with little stress on the cage itself. The design minimizes the contact area and force required for roller guidance, and thus minimizes drag between cage and rollers.

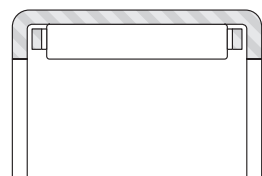

Fig. B-9. Caged bearing

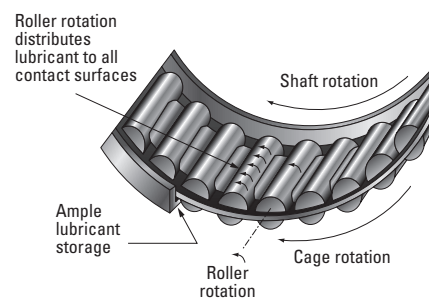

Fig. B-10. Cage design

The same design feature that assures no contact between roller retention bars and rollers while the bearing is operating, also provides ample clearance along the length of the roller to enhance the circulation of lubricant.

There are bearings with other cage designs. Bearings with engineered polymer cages are for use where operating conditions permit. Before applying bearings with engineered polymer cages, please consult your representative.

SEALED BEARINGS

Drawn cup caged needle roller bearings are offered with integral seals. The tables of dimensions on pages B-118 and B-119 indicate those sizes available with lip contact seals which limit the bearing operating temperature between -30° C and 110° C (-25° F and 225° F). The seal lip design achieves a light and constant contact with the shaft throughout the range of mounting bearing clearances thereby ensuring positive sealing and low frictional drag.

Sealed drawn cup bearings are intended to retain grease or non-pressurized oil within a bearing while also preventing contaminants from entering the raceway area.

Details of shaft design for sealed bearings are given in the engineering section.

The standard lip contact seals are compatible with common lubricating oils and petroleum based fuels. But they are adversely affected by certain fire-resistant hydraulic fluids and most common solvents.

If the operating temperature must be outside of the specified range, or if the seals are exposed to unusual fluids, please consult your representative.

DIMENSIONAL ACCURACY AND MOUNTING DIMENSIONS

MANUFACTURING TOLERANCES AND RESULTING CLEARANCES

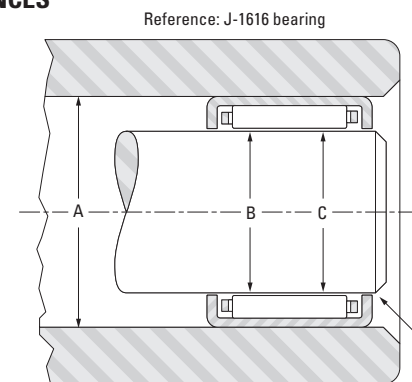

- A. Housing bore tolerance 0.025 mm (0.0010in)
B. Manufacturing tolerance for bearing 0.023 mm (0.0009 in)
C. Shaft diameter tolerance 0.013 mm (0.0005 in)
D. Min. Initial radial clearance 0.013 mm (0.0005 in)

Fig. B-11. Manufacturing tolerances and resulting clearances

BEARING MOUNTING FITS AND RADIAL INTERNAL CLEARANCE

Drawn cup bearings are manufactured to a degree of precision that will satisfy the radial clearance requirements of most applications. The total radial clearance of an installed drawn cup bearing results from the buildup of manufacturing tolerances of the housing bore, inner raceway O.D., and the bearing – as well as the minimum radial clearance required for the application.

For bearings of nominal inch dimensions, the suggested mounting dimensions will provide correct running clearance for most applications. Closer control of radial clearance would be governed by the user's capability of holding housing and shaft raceway dimensional tolerances tighter than the limits shown in the bearing tables.

The drawing illustrates the manufacturing tolerances and resulting clearances applying to medium size drawn cup bearings, in rotating applications, when using the suggested tabulated mounting dimensions.

Radial clearance in a mounted bearing may be more closely controlled by reducing the manufacturing tolerances of the housing bore and inner raceway diameter. Where extremely close control of radial clearance is required for bearings of nominal inch dimensions, extra-precision full complement bearings are available (see page B-106).

TOLERANCES FOR HOUSING MATERIALS OF LOW RIGIDITY

For housing materials of low rigidity, or steel housings of small section, it is suggested that for initial trial the housing bore diameters given in the bearing tables be reduced by the amounts shown in Table B-10. To maintain normal radial internal clearance, the inner raceway diameter tolerance given in the bearing tables should be used.

Table B-10. Low Rigidity Housing Bore

Table with 6 columns: Over, Incl., Over, Incl., Subtract (mm, in). Rows show nominal housing bore values from 0.0 to 76.2 mm.

OUTER RING ROTATION

For applications where the outer ring rotates with respect to the load, it is suggested that both the housing bore and inner raceway diameter be reduced. Bearings of nominal inch dimensions should have the housing bore and inner raceway diameters reduced by 0.013 mm (0.0005 in)

OSCILLATING MOTION

Applications involving oscillating motion often require reduced radial clearances. This reduction is accomplished by increasing the shaft raceway diameters as shown in Table B-11.

Table B-11. Nominal inch bearing oscillating shaft size

Table with 4 columns: Shaft size (mm, in), Add (mm, in). Rows show shaft size ranges from 2.38 to 4.76 mm.



INNER RINGS

Where it becomes impractical to meet the shaft raceway design requirements (hardness, case depth, surface finish, etc.) outlined in the engineering section, standard inner rings for drawn cup bearings are available. These are tabulated on pages B-120 to B-122 of the drawn cup section.

Inner rings for drawn cup bearings are designed to be a loose transition fit on the shaft and should be clamped against a shoulder. If a tight transition fit must be used to keep the inner ring from rotating relative to the shaft, the inner ring O.D., as mounted, must not exceed the raceway diameters required by the drawn cup bearing for the particular application.

LUBRICATION

Inch series drawn cup bearings can be furnished with an oil hole (centered in the drawn cup) to facilitate re-lubrication. If desired, specify in order by adding an -OH suffix to the bearing designation.

LOAD RATING FACTORS

Dynamic Loads

Drawn cup needle roller bearings can accommodate only radial loads.

$$P = F_r$$

P = The maximum dynamic radial load that may be applied to a drawn cup bearing based on the dynamic load rating, C given in the bearing tables. This load should be $\leq C/3$.

Static Loads

$$f_0 = \frac{C_0}{P_0}$$

f_0 = static load safety factor

C_0 = basic static load rating

P_0 = maximum applied static load

To ensure satisfactory operation of drawn cup needle roller bearings under all types of conditions the static load safety factor f_0 should be ≥ 3 .

ADJUSTED RATING LIFE

When application data includes details of operating temperature, oil viscosity, operating speed and the applied load meets the $\leq C/3$ condition, adjusted rating life may be evaluated using the information given in the engineering section of this catalog.

INSPECTION PROCEDURES

Although the bearing cup (outer ring) is accurately drawn from strip steel it may go out of round during heat treatment. When the bearing is pressed into a true, round housing or ring gage of correct size and wall thickness, it becomes round and is sized properly. For this reason, it is incorrect to inspect an unmounted drawn cup bearing by measuring the O.D. The correct method for inspecting the bearing size is to:

1. Press the bearing into a ring gage of proper size.
2. Plug the bearing bore with the appropriate "go" and "no go" gages.

Table B-12 on page B-89 provides the correct ring and plug gage diameters for inspecting Torrington drawn cup needle roller bearings. When the letter **H** appears in the columns headed "Bearing Bore Designation" and "Nominal Shaft Diameter," the gage sizes listed are for the larger cross section bearings which include **H** in their bearing designation prefix.

Example

Find the ring gage and plug gage dimensions for a BH-68 bearing.

The nominal bore diameter (F_w) for this bearing, as shown in the table of dimensions on page B-89, is 9.525 mm (0.3750 in). Since the letter H appears in the bearing designation, the following information will be found opposite H6 9.525 mm (0.3750 in) in Table B-12 on page B-89.

	in
ring gage	0.6255
diameter under needle rollers, min.	0.3765
diameter under needle rollers, max.	0.3774

The "go" plug gage is the same size as the minimum needle roller complement bore diameter and the "no go" plug gage size is 0.002 mm (0.0001 in) larger than the maximum bore diameter. Therefore the correct ring and plug gage dimensions are:

	in
ring gage	0.6255
plug gage, "go"	0.3765
plug gage, "no go"	0.3775

These same gage dimensions also apply to JH-68.

Table B-12. Ring and plug gage dimensions

Bearing bore designation	Nominal shaft diameter	Nominal bore diameter	Ring gage	Needle roller complement bore diameter	
				Max.	Min.
	mm in	mm in	mm in	mm in	mm in
2	3.175 1/8	3.175 0.1250	6.363 0.2505	3.218 0.1267	3.195 0.1258
2 1/2	3.970 5/32	3.967 0.1562	7.155 0.2817	4.013 0.1580	3.99 0.1571
3	4.763 3/16	4.763 0.1875	8.730 0.3437	4.806 0.1892	4.783 0.1883
4	6.350 1/4	6.350 0.2500	11.125 0.4380	6.411 0.2524	6.388 0.2515
5	7.938 5/16	7.938 0.3125	12.713 0.5005	7.998 0.3149	7.976 0.3140
H 5	H 7.938 H 5/16	7.938 0.3125	14.300 0.5630	7.998 0.3149	7.976 0.3140
6	9.525 3/8	9.525 0.3750	14.300 0.5630	9.586 0.3774	9.563 0.3765
H 6	H 9.525 H 3/8	9.525 0.3750	15.888 0.6255	9.586 0.3774	9.563 0.3765
7	11.113 7/16	11.113 0.4375	15.888 0.6255	11.174 0.4399	11.151 0.4390
H 7	H 11.113 H 7/16	11.113 0.4375	17.475 0.6880	11.174 0.4399	11.151 0.4390
8	12.700 1/2	12.700 0.5000	17.475 0.6880	12.761 0.5024	12.738 0.5015
H 8	H 12.700 H 1/2	12.700 0.5000	19.063 0.7505	12.761 0.5024	12.738 0.5015
9	14.288 9/16	14.288 0.5625	19.063 0.7505	14.349 0.5649	14.326 0.5640
H 9	H 14.288 H 9/16	14.288 0.5625	20.650 0.8130	14.349 0.5649	14.326 0.5640
10	15.875 5/8	15.875 0.6250	20.650 0.8130	14.349 0.6274	15.913 0.6265
H 10	H 15.875 H 5/8	15.875 0.6250	22.238 0.8755	14.349 0.6274	15.913 0.6265
11	17.463 1 1/16	17.463 0.6875	22.238 0.8755	17.524 0.6899	17.501 0.6890
H 11	H 17.463 H 1 1/16	17.463 0.6875	23.825 0.9380	17.524 0.6899	17.501 0.6890
12	19.050 3/4	19.050 0.7500	25.387 0.9995	19.086 0.7514	19.063 0.7505
H 12	H 19.050 H 3/4	19.050 0.7500	26.975 1.0620	19.086 0.7514	19.063 0.7505
13	20.638 13/16	20.638 0.8125	26.975 1.0620	20.673 0.8139	20.650 0.8130
H 13	H 20.638 H 13/16	20.638 0.8125	28.562 1.1245	20.673 0.8139	20.650 0.8130
14	22.225 7/8	22.225 0.8750	28.562 1.1245	22.261 0.8764	22.238 0.8755
H 14	H 22.225 H 7/8	22.225 0.8750	30.150 1.1870	22.261 0.8764	22.238 0.8755
15	23.813 19/16	23.813 0.9375	30.150 1.1870	23.848 0.9389	23.825 0.9380
16	25.400 1	25.400 1.0000	31.737 1.2495	25.436 1.0014	25.413 1.0005
H 16	H 25.400 H 1	25.400 1.0000	33.325 1.3120	25.436 1.0014	25.413 1.0005
17	26.988 1 1/16	26.988 1.0625	33.325 1.3120	27.023 1.0639	27.000 1.0630
18	28.575 1 1/8	28.575 1.1250	34.912 1.3745	28.611 1.1264	28.588 1.1255
H 18	H 28.575 H 1 1/8	28.575 1.1250	38.087 1.4995	28.611 1.1264	28.588 1.1255
19	30.163 1 3/16	30.163 1.1875	38.087 1.4995	30.198 1.1889	30.175 1.1880
20	31.750 1 1/4	31.750 1.2500	38.087 1.4995	31.786 1.2514	31.763 1.2505
H 20	H 31.750 H 1 1/4	31.750 1.2500	41.262 1.6245	31.786 1.2514	31.763 1.2505
21	33.338 1 3/16	33.338 1.3125	41.262 1.6245	33.376 1.3140	33.350 1.3130
22	34.925 1 3/8	34.925 1.3750	41.262 1.6245	34.963 1.3765	34.938 1.3755
H 22	H 34.925 H 1 3/8	34.925 1.3750	44.437 1.7495	34.963 1.3765	34.938 1.3755
24	38.100 1 1/2	38.100 1.5000	47.612 1.8745	38.141 1.5016	38.113 1.5005
26	41.275 1 5/8	41.275 1.6250	50.787 1.9995	41.316 1.6266	41.288 1.6255
28	44.450 1 3/4	44.450 1.7500	53.962 2.1245	44.493 1.7517	44.463 1.7505
30	47.625 1 7/8	47.625 1.8750	57.137 2.2495	47.668 1.8767	47.638 1.8755
32	50.800 2	50.800 2.0000	60.312 2.3745	50.846 2.0018	50.815 2.0006
H 33	H 52.388 H 2 1/16	52.388 2.0625	64.280 2.5307	52.436 2.0644	52.400 2.0630
34	53.975 2 1/8	53.975 2.1250	63.487 2.4995	54.026 2.1270	53.990 2.1256
36	57.150 2 1/4	57.150 2.2500	66.662 2.6245	57.201 2.2520	57.165 2.2506
42	66.675 2 5/8	66.675 2.6250	76.187 2.9995	66.736 2.6274	66.700 2.6260
44	69.850 2 3/4	69.850 2.7500	79.362 3.1245	69.911 2.7524	69.875 2.7510
56	88.900 3 1/2	88.900 3.5000	101.587 3.9995	88.961 3.5024	88.925 3.5010
88	139.700 5 1/2	139.700 5.5000	152.375 5.9990	139.774 5.5029	139.725 5.5010

Bearing bore should be checked with "go" and "no go" plug gages. The "go" gage size is the minimum needle roller complement bore diameter. The "no go" gage size is larger than the maximum needle roller complement bore diameter by 0.0001 in



INSTALLATION OF DRAWN CUP BEARINGS

GENERAL INSTALLATION REQUIREMENTS

- A drawn cup bearing must be pressed into its housing.
- An installation tool, similar to the ones shown, must be used in conjunction with a standard press.
- The bearing must not be hammered into its housing – even in conjunction with the proper assembly mandrel.
- The bearing must not be pressed tightly against a shoulder in the housing.
- If it is necessary to use a shouldered housing, the depth of the housing bore must be sufficient to ensure the housing shoulder fillet, and the shoulder face, clear the bearing.
- The installation tool must be coaxial with the housing bore.

INSTALLATION OF OPEN END BEARINGS

It is advisable to utilize a positive stop on the press tool to locate the bearing properly in the housing. The assembly tool should have a leader or a pilot, as shown, to aid in starting the bearing true in the housing. The ball detent shown on the drawing is used to assist in aligning the rollers of a full complement bearing during installation and to hold the bearing on the installation tool. A caged-type drawn cup bearing does not require a ball detent to align its rollers. The ball detent may still be used to hold the bearing on the installation tool or an "O" ring may be used as shown in the drawing on this page. The bearing should be installed with the marked end (the end with identification markings) against the angled shoulder of the pressing tool.

- A – 0.40 mm (0.016 in) less than housing bore
- B – 0.08 mm (0.003 in) less than shaft diameter
- C – distance bearing will be inset into housing, minimum of 0.20 mm (0.008 in)
- D – pilot length should be length of bearing less 0.80 mm (0.030 in)
- E – approximately 1/2 D

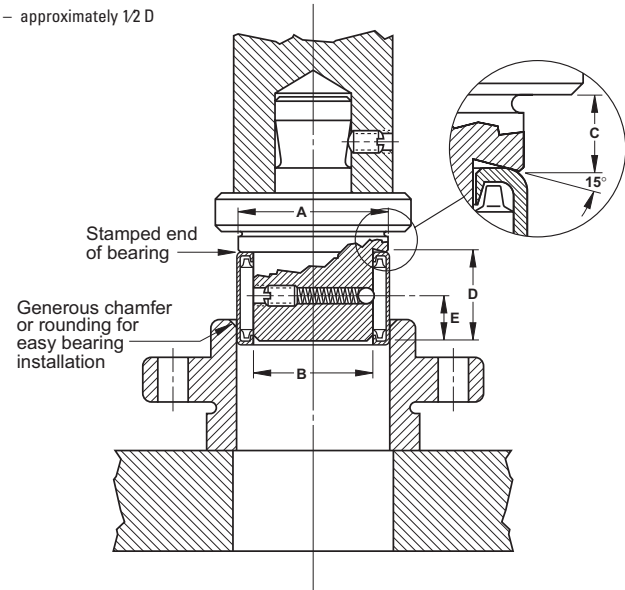

Fig. B-12. Installation of open ends caged bearings

- A – 0.40 mm (0.016 in) less than housing bore
- B – 0.08 mm (0.003 in) less than shaft diameter
- C – distance bearing will be inset into housing, minimum of 0.20 mm (0.008 in)
- D – pilot length should be length of bearing less 0.80 mm (0.030 in)
- E – approximately 1/2 D

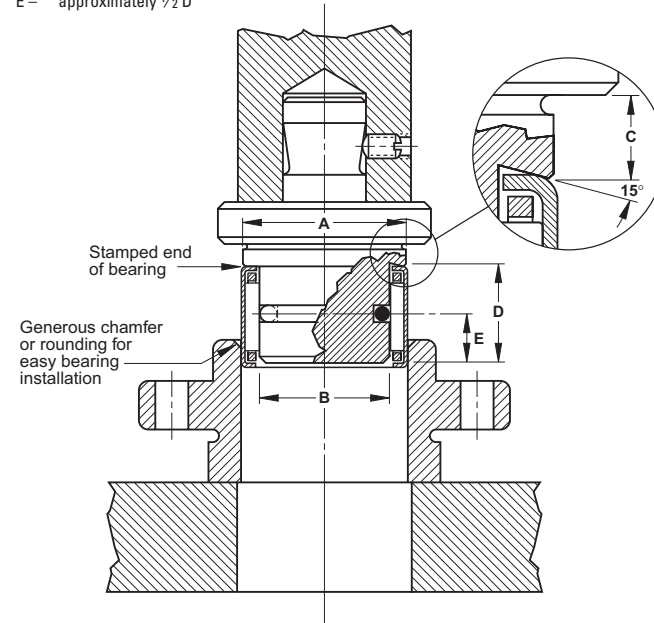

Fig. B-13. Installation of open ends full complement bearings

INSTALLATION OF CLOSED END BEARINGS

The installation tool combines all the features of the tool used to install open end bearings. But the pilot is spring loaded and is part of the press bed.

The angled shoulder of the pressing tool should bear against the closed end, with the bearing held on the pilot, to aid in starting the bearing true in the housing.

- A – 0.40 mm (0.016 in) less than housing bore
- B – 0.08 mm (0.003 in) less than shaft diameter
- C – distance bearing will be inset into housing, minimum of 0.20 mm (0.008 in)

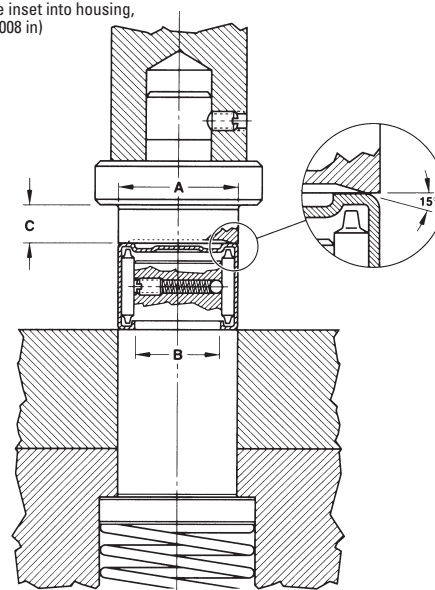

Fig. B-14. Installation of closed end bearings

EXTRACTION OF DRAWN CUP BEARINGS

The need to extract a drawn cup bearing does not arise often. Standard extractor tools may be purchased from a reputable manufacturer. Customers may produce the special extraction tools at their own facilities. After extraction, the drawn cup bearing should not be reused.

EXTRACTION FROM A STRAIGHT HOUSING

When it is necessary to extract a drawn cup bearing from a straight housing, a similar tool to the installation tool – but without the stop – may be used. To avoid damage to the bearing, pressure should be applied against the marked end of the bearing, just as it is done at installation.

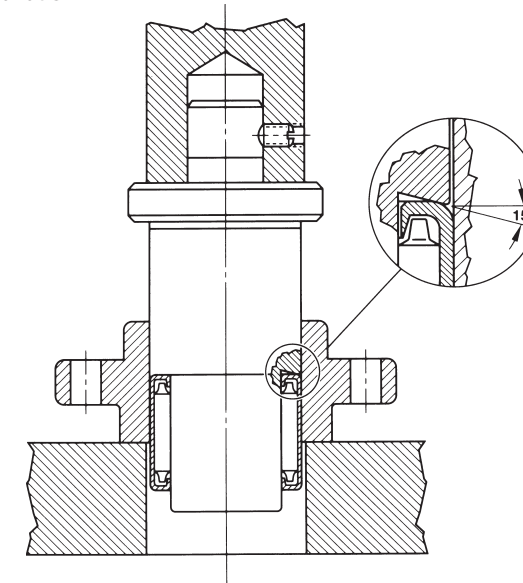

Fig. B-15. Extraction from a straight housing

EXTRACTION FROM A SHOULDERED HOUSING

(with bearing pressed up close to the shoulder)

The tool to be used, as shown, is of a similar type described for a shouldered or dead end housing. But the rollers must first be removed from the bearing.

The four segment puller jaws are collapsed and slipped into the empty cup. The jaws are then forced outward into the cup bore, by means of the tapered expansion rod. The jaws should bear on the lip as near as possible to the cup bore. The cup is then pressed out from the top.

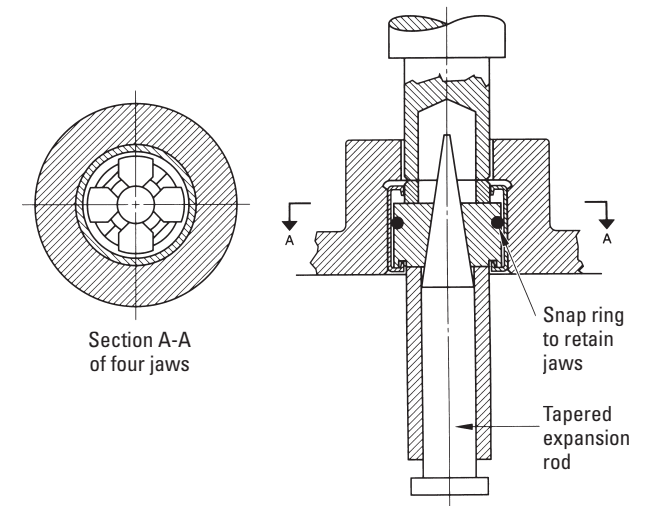

Fig. B-16. Extraction from a shouldered housing

EXTRACTION FROM A SHOULDERED OR DEAD END HOUSING

(with space between the bearing and the housing shoulder)

Bearings may be extracted from shouldered or dead end housings with a common bearing puller tool as shown. This type of tool is slotted in two places, at right angles, to form four prongs. The four puller prongs are pressed together and inserted into the space between the end of the bearing and the shoulder. The prongs are forced outward by inserting the expansion rod, and then the bearing is extracted. Do not reuse the bearing after extraction.

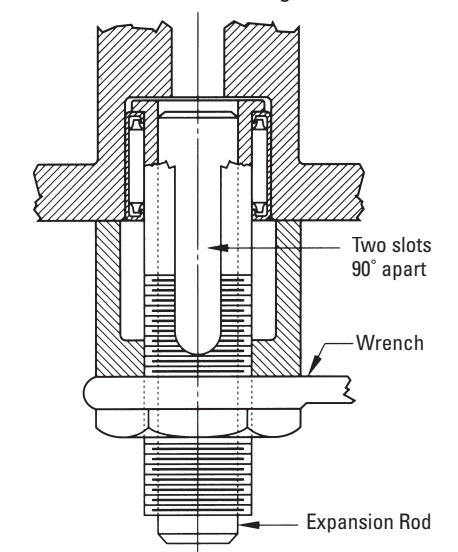
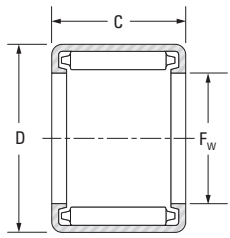

Fig. B-17. Extraction from a shouldered or dead end housing



FULL COMPLEMENT BEARINGS, OPEN ENDS, CLOSED ONE END

INCH SERIES



B, BH

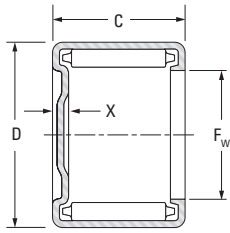

M-1, MH-1

Full Complement Bearing

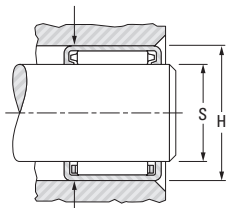

Caged Bearing

Shaft surface to be 58 HRC or equivalent

Drawn cup bearings of nominal inch dimensions, with one closed end, that are not tabulated, may be made available upon request.

Mounting dimensions are based on the inner ring rotating and the outer ring being stationary, relative to the load. The housing should be of high strength material.

See Engineering section for discussion of shaft and housing design.

Table with columns for Shaft Dia., Fw, D, C, X, Bearing Designation, Load Ratings (Dynamic, Static), Speed Rating (Grease, Oil), and Cg. Rows list various bearing models like B-24, B-2 1/2 4, B-2 1/2 5, B-34, B-36, B-44, B-45, B-46, B-47, B-55, B-56, B-57, B-59, BH-57, BH-59, B-65, B-66, B-67, B-68, B-69, B-610, BH-68, B-76, B-77, B-78.

Table with columns for Approx. Wt. (Open Ends, Closed End), S (Max., Min.), H (Max., Min.), Inspection (Ring Gage, Plug Gage), Mounting Inner Ring, and Shaft Dia. Rows list various bearing models with their respective weight and dimension values.

Continued on next page.



FULL COMPLEMENT BEARINGS,
OPEN ENDS, CLOSED ONE END – continued

INCH SERIES

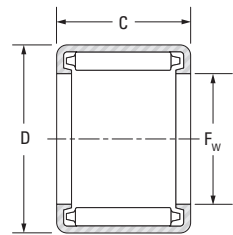

B, BH

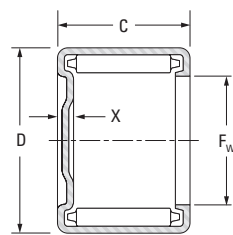

M-1, MH-1

Full Complement Bearing

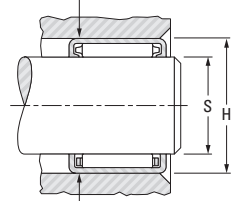

Caged Bearing

Shaft surface to be 58 HRC or equivalent

Drawn cup bearings of nominal inch dimensions, with one closed end, that are not tabulated, may be made available upon request.

Mounting dimensions are based on the inner ring rotating and the outer ring being stationary, relative to the load. The housing should be of high strength material.

See Engineering section for discussion of shaft and housing design.

Shaft Dia.	F _w	D	C		X (max.)	Bearing Designation	Load Ratings		Speed Rating		C _g
			+0 +0.000	-0.3 -0.010			Dynamic	Static	Grease	Oil	
			mm	mm			C	C ₀			
in	mm in	mm in	mm in	mm in			kN lbf		min ⁻¹		
5/8	15.875 0.6250	20.638 0.8125	19.05 0.750	2.03 0.080	B-1012	M-10121	16.6 3720	33.7 7580	3000	4500	0.0314
	15.875 0.6250	22.212 0.8745	12.70 0.500	2.29 0.090	BH-108	MH-1081	12.7 2860	18.3 4110	4200	6500	0.0256
	15.875 0.6250	22.212 0.8745	15.88 0.625	—	BH-1010	—	16.4 3680	25.3 5680	4200	6500	0.0278
	15.875 0.6250	22.212 0.8745	19.05 0.750	—	BH-1012	—	19.8 4450	32.3 7250	4200	6500	0.0295
	15.875 0.6250	22.212 0.8745	25.40 1.000	—	BH-1016	—	26.2 5890	46.3 10400	4200	6500	0.0322
11/16	17.463 0.6875	22.212 0.8745	9.53 0.375	2.03 0.080	B-116	M-1161	8.18 1840	14.0 3140	2700	4200	0.0263
	17.463 0.6875	22.212 0.8745	12.70 0.500	2.03 0.080	B-118	M-1181	11.5 2580	21.7 4880	2700	4200	0.0293
	17.463 0.6875	22.212 0.8745	15.88 0.625	2.03 0.080	B-1110	M-11101	14.6 3270	29.4 6610	2700	4200	0.0316
	17.463 0.6875	22.212 0.8745	19.05 0.750	2.03 0.080	B-1112	M-11121	17.4 3920	37.1 8340	2700	4200	0.0335
	17.463 0.6875	23.813 0.9375	11.13 0.438	—	BH-117	—	11.4 2560	16.2 3650	3900	6000	0.0259
	17.463 0.6875	23.813 0.9375	15.88 0.625	2.29 0.090	BH-1110	MH-11101	17.3 3890	27.8 6250	3900	6000	0.0296
	17.463 0.6875	23.813 0.9375	19.05 0.750	—	BH-1112	—	20.9 4700	35.5 7980	3900	6000	0.0314
3/4	19.050 0.7500	25.400 1.0000	9.53 0.375	2.29 0.090	B-126	M-1261	9.7 2180	13.6 3050	3600	5600	0.0256
	19.050 0.7500	25.400 1.0000	12.70 0.500	2.29 0.090	B-128	M-1281	14.1 3170	22.0 4940	3600	5600	0.0289
	19.050 0.7500	25.400 1.0000	15.88 0.625	2.29 0.090	B-1210	M-12101	18.2 4080	30.3 6820	3600	5600	0.0313
	19.050 0.7500	25.400 1.0000	19.05 0.750	2.29 0.090	B-1212	M-12121	21.9 4930	38.7 8710	3600	5600	0.0333
13/16	20.638 0.8125	26.988 1.0625	9.53 0.375	—	B-136	—	10.1 2280	14.7 3300	3400	5200	0.0271
	20.638 0.8125	26.988 1.0625	12.70 0.500	2.29 0.090	B-138	M-1381	14.8 3320	23.8 5350	3400	5200	0.0305
	20.638 0.8125	26.988 1.0625	22.23 0.875	2.29 0.090	B-1314	M-13141	26.7 6010	51.2 11500	3400	5200	0.0369
	20.638 0.8125	26.988 1.0625	25.40 1.000	2.29 0.090	B-1316	M-13161	30.3 6820	60.1 13500	3400	5200	0.0384
	20.638 0.8125	26.988 1.0625	31.75 1.250	—	B-1320	—	37.3 8380	78.3 17600	3500	5200	0.0410
	20.643 0.8125	28.575 1.1250	12.70 0.500	2.79 0.110	BH-138	MH-1381	14.9 3340	20.8 4680	4100	6300	0.0287
	20.638 0.8125	28.575 1.1250	15.88 0.625	2.79 0.110	BH-1310	MH-13101	19.7 4430	29.9 6720	4100	6300	0.0314
	20.638 0.8125	28.575 1.1250	19.05 0.750	2.79 0.110	BH-1312	MH-13121	24.2 5440	39.0 8760	4100	6300	0.0336
7/8	22.225 0.8750	28.575 1.1250	9.53 0.375	2.29 0.090	B-146	M-1461	10.5 2370	15.8 3560	3100	4800	0.0285

Approx. Wt.		S		H		Inspection			Mounting Inner Ring (pg B-120 to B-122)	Shaft Dia.
Open Ends	Closed End	Recommended Mounting Dimension				Ring Gage	Plug Gage			
		Max.	Min.	Max.	Min.		Go	No Go		
kg lbs	kg lbs	mm in	mm in	mm in	mm in					in
0.015 0.034	0.017 0.038	15.875 0.6250	15.862 0.6245	20.650 0.8130	20.625 0.8120	20.650 0.8130	15.913 0.6265	15.939 0.6275	IR-612-1	5/8
0.014 0.031	0.016 0.035	15.875 0.6250	15.862 0.6245	22.238 0.8755	22.212 0.8745	22.238 0.8755	15.913 0.6265	15.939 0.6275	IR-68-1	
0.018 0.039	—	15.875 0.6250	15.862 0.6245	22.238 0.8755	22.212 0.8745	22.238 0.8755	15.913 0.6265	15.939 0.6275	IR-612-1	
0.021 0.047	—	15.875 0.6250	15.862 0.6245	22.238 0.8755	22.212 0.8745	22.238 0.8755	15.913 0.6265	15.939 0.6275	IR-612-1	
0.028 0.062	—	15.875 0.6250	15.862 0.6245	22.238 0.8755	22.212 0.8745	22.238 0.8755	15.913 0.6265	15.939 0.6275		
0.008 0.018	0.009 0.020	17.463 0.6875	17.450 0.6870	22.238 0.8755	22.212 0.8745	22.238 0.8755	17.501 0.6890	17.526 0.6900		11/16
0.011 0.024	0.012 0.027	17.463 0.6875	17.450 0.6870	22.238 0.8755	22.212 0.8745	22.238 0.8755	17.501 0.6890	17.526 0.6900		
0.014 0.030	0.015 0.034	17.463 0.6875	17.450 0.6870	22.238 0.8755	22.212 0.8745	22.238 0.8755	17.501 0.6890	17.526 0.6900		
0.016 0.036	0.019 0.041	17.463 0.6875	17.450 0.6870	22.238 0.8755	22.212 0.8745	22.238 0.8755	17.501 0.6890	17.526 0.6900		
0.014 0.030	—	17.463 0.6875	17.450 0.6870	23.825 0.9380	23.800 0.9370	23.825 0.9380	17.501 0.6890	17.526 0.6900		
0.019 0.042	0.021 0.047	17.463 0.6875	17.450 0.6870	23.825 0.9380	23.800 0.9370	23.825 0.9380	17.501 0.6890	17.526 0.6900		
0.023 0.051	—	17.463 0.6875	17.450 0.6870	23.825 0.9380	23.800 0.9370	23.825 0.9380	17.501 0.6890	17.526 0.6900		
0.012 0.027	0.014 0.031	19.050 0.7500	19.037 0.7495	25.413 1.0005	25.387 0.9995	25.387 0.9995	19.063 0.7505	19.088 0.7515	IR-88	3/4
0.016 0.036	0.019 0.041	19.050 0.7500	19.037 0.7495	25.413 1.0005	25.387 0.9995	25.387 0.9995	19.063 0.7505	19.088 0.7515	IR-88	
0.020 0.045	0.024 0.052	19.050 0.7500	19.037 0.7495	25.413 1.0005	25.387 0.9995	25.387 0.9995	19.063 0.7505	19.088 0.7515	IR-812 ⁽¹⁾	
0.024 0.054	0.028 0.062	19.050 0.7500	19.037 0.7495	25.413 1.0005	25.387 0.9995	25.387 0.9995	19.063 0.7505	19.088 0.7515	IR-812 ⁽¹⁾	
0.013 0.029	—	20.638 0.8125	20.625 0.8120	27.000 1.0630	26.975 1.0620	26.975 1.0620	20.650 0.8130	20.676 0.8140		13/16
0.018 0.039	0.020 0.044	20.638 0.8125	20.625 0.8120	27.000 1.0630	26.975 1.0620	26.975 1.0620	20.650 0.8130	20.676 0.8140		
0.031 0.068	0.035 0.077	20.638 0.8125	20.625 0.8120	27.000 1.0630	26.975 1.0620	26.975 1.0620	20.650 0.8130	20.676 0.8140		
0.035 0.078	0.040 0.088	20.638 0.8125	20.625 0.8120	27.000 1.0630	26.975 1.0620	26.975 1.0620	20.650 0.8130	20.676 0.8140		
0.044 0.098	—	20.638 0.8125	29.625 0.8120	27.000 1.0630	26.975 1.0620	26.975 1.0620	20.650 0.8130	20.676 0.8140		
0.023 0.050	0.026 0.057	20.638 0.8125	20.625 0.8120	28.588 1.1255	28.562 1.1245	28.562 1.1245	20.650 0.8130	20.676 0.8140		
0.029 0.063	0.032 0.071	20.638 0.8125	20.625 0.8120	28.588 1.1255	28.562 1.1245	28.562 1.1245	20.650 0.8130	20.676 0.8140		
0.034 0.076	0.039 0.086	20.638 0.8125	20.625 0.8120	28.588 1.1255	28.562 1.1245	28.562 1.1245	20.650 0.8130	20.676 0.8140		
0.014 0.031	0.016 0.035	22.225 0.8750	22.212 0.8745	28.588 1.1255	28.562 1.1245	28.562 1.1245	22.238 0.8755	22.263 0.8765		7/8

⁽¹⁾ IRA inner ring provides additional length if required.

Continued on next page.



FULL COMPLEMENT BEARINGS, OPEN ENDS, CLOSED ONE END - continued

INCH SERIES

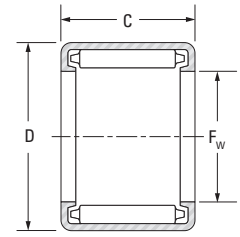

B, BH

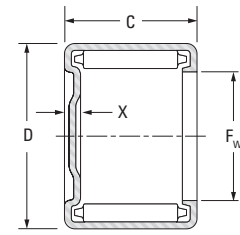

M-1, MH-1

Full Complement Bearing

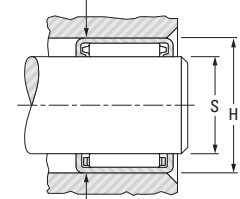

Caged Bearing

Shaft surface to be 58 HRC or equivalent

Drawn cup bearings of nominal inch dimensions, with one closed end, that are not tabulated, may be made available upon request.

Mounting dimensions are based on the inner ring rotating and the outer ring being stationary, relative to the load. The housing should be of high strength material.

See Engineering section for discussion of shaft and housing design.

Table with columns for Shaft Dia., Fw, D, C, X, Bearing Designation, Load Ratings (Dynamic/Static), Speed Rating (Grease/Oil), and Cg. Rows include various bearing models like B-148, B-1412, B-1416, B-1418, BH-1410, BH-1412, BH-1416, B-158, B-1516, B-166, B-167, B-168, B-1610, B-1612, B-1616, BH-168, BH-1610, BH-1612, BH-1614, BH-1616, BH-1620, BH-1624, B-1710, BH-1712, and B-186.

Table with columns for Approx. Wt. (Open/Closed Ends), S (Max./Min.), H (Max./Min.), Inspection (Ring Gage, Plug Gage), Mounting Inner Ring, and Shaft Dia. Rows include various bearing models like B-019, B-028, B-038, B-043, B-030, B-036, B-049, B-020, B-040, B-016, B-019, B-021, B-026, B-032, B-043, B-027, B-034, B-041, B-048, B-054, B-068, B-082, B-028, B-035, and B-018.

(1) IRA inner ring provides additional length if required.

Continued on next page.



**FULL COMPLEMENT BEARINGS,
OPEN ENDS, CLOSED ONE END – continued**

INCH SERIES

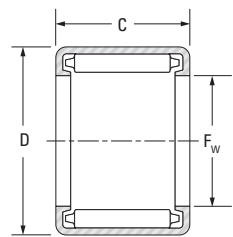

B, BH

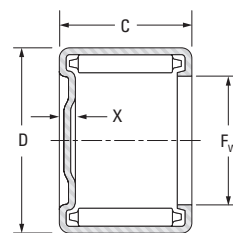

M-1, MH-1

Full Complement Bearing

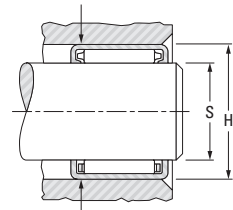

Caged Bearing

Shaft surface to be 58 HRC or equivalent

Drawn cup bearings of nominal inch dimensions, with one closed end, that are not tabulated, may be made available upon request.

Mounting dimensions are based on the inner ring rotating and the outer ring being stationary, relative to the load. The housing should be of high strength material.

See Engineering section for discussion of shaft and housing design.

Shaft Dia.	F _w	D	C		X (max.)	Bearing Designation	Load Ratings		Speed Rating		C ₉			
			+0.000 -0.3 -0.010	mm			mm	mm	mm	Dynamic		Static	Grease	Oil
										C		C ₀		
in	mm in	mm in	mm in	mm in			kN lbf		min ⁻¹					
	28.575 1.1250	34.925 1.3750	12.70 0.500	2.29 0.090	B-188	M-1881	17.6 3950	33.0 7420	2500	3800	0.0381			
	28.575 1.1250	34.925 1.3750	15.88 0.625	—	B-1810	—	22.6 5080	45.8 10300	2500	3800	0.0413			
	28.575 1.1250	34.925 1.3750	19.05 0.750	2.29 0.090	B-1812	M-18121	27.3 6140	58.3 13100	2500	3800	0.0438			
	28.575 1.1250	34.925 1.3750	25.40 1.000	2.29 0.090	B-1816	M-18161	36.2 8130	83.6 18800	2500	3800	0.0479			
	28.575 1.1250	38.100 1.5000	19.05 0.750	3.05 0.120	BH-1812	MH-18121	31.5 7090	52.9 11900	3600	5600	0.0405			
	28.575 1.1250	38.100 1.5000	25.40 1.000	3.05 0.120	BH-1816	MH-18161	42.5 9560	77.8 17500	3600	5600	0.0446			
	28.575 1.1250	38.100 1.5000	31.75 1.250	3.05 0.120	BH-1820	MH-18201	52.9 11900	103.2 23200	3600	5600	0.0479			
1 3/16	30.163 1.1875	38.100 1.5000	15.88 0.625	2.79 0.110	B-1910	M-19101	24.1 5420	43.8 9840	2900	4400	0.0406			
	30.163 1.1875	38.100 1.5000	25.40 1.000	—	B-1916	—	40.0 8980	83.6 18800	2900	4400	0.0477			
1 1/4	31.750 1.2500	38.100 1.5000	12.70 0.500	2.29 0.090	B-208	M-2081	18.6 4170	36.6 8240	2300	3500	0.0409			
	31.750 1.2500	38.100 1.5000	15.88 0.625	2.29 0.090	B-2010	M-20101	23.9 5370	50.7 11400	2300	3500	0.0444			
	31.750 1.2500	38.100 1.5000	19.05 0.750	2.29 0.090	B-2012	M-20121	28.9 6490	64.5 14500	2300	3500	0.0471			
	31.750 1.2500	38.100 1.5000	25.40 1.000	2.29 0.090	B-2016	M-20161	38.2 8590	92.5 20800	2300	3500	0.0515			
	31.750 1.2500	38.100 1.5000	31.75 1.250	2.29 0.090	B-2020	M-20201	47.2 10600	121.0 27200	2300	3500	0.0550			
	31.750 1.2500	41.275 1.6250	12.70 0.500	3.05 0.120	BH-208	MH-2081	19.7 4420	30.0 6750	3300	5000	0.0369			
	31.750 1.2500	41.275 1.6250	19.05 0.750	3.05 0.120	BH-2012	MH-20121	33.1 7440	58.7 13200	3300	5000	0.0435			
	31.750 1.2500	41.275 1.6250	25.40 1.000	3.05 0.120	BH-2016	MH-20161	44.9 10100	86.7 19500	3300	5000	0.0480			
	31.750 1.2500	41.275 1.6250	31.75 1.250	3.05 0.120	BH-2020	MH-20201	56.0 12600	115.0 25800	3300	5000	0.0515			
1 5/16	33.338 1.3125	41.275 1.6250	12.70 0.500	2.79 0.110	B-218	M-2181	19.3 4330	33.7 7570	2600	4100	0.0397			
	33.338 1.3125	41.275 1.6250	15.88 0.625	2.79 0.110	B-2110	M-21101	25.5 5740	48.5 10900	2600	4100	0.0435			
	33.338 1.3125	41.275 1.6250	31.75 1.250	—	B-2120	—	52.5 11800	122.0 27500	2600	4100	0.0547			
1 3/8	34.925 1.3750	41.275 1.6250	12.70 0.500	2.29 0.090	B-228	M-2281	19.5 4390	40.4 9070	2100	3200	0.0437			
	34.925 1.3750	41.275 1.6250	19.05 0.750	2.29 0.090	B-2212	M-22121	30.4 6830	71.2 16000	2100	3200	0.0504			
	34.925 1.3750	41.275 1.6250	25.40 1.000	2.29 0.090	B-2216	M-22161	40.2 9030	102.0 22900	2100	3200	0.0551			
	34.925 1.3750	41.275 1.6250	31.75 1.250	2.29 0.090	B-2220	M-22201	49.4 11100	133.0 29900	2100	3200	0.0588			

Approx. Wt.		S		H		Inspection			Mounting Inner Ring (pg B-120 to B-122)	Shaft Dia. in
Open Ends	Closed End	Recommended Mounting Dimension				Ring Gage	Plug Gage			
		Max.	Min.	Max.	Min.		Go	No Go		
kg lbs	kg lbs	mm in	mm in	mm in	mm in					
0.024 0.052	0.027 0.059	28.575 1.1250	28.562 1.1245	34.938 1.3755	34.912 1.3745	34.912 1.3745	28.588 1.1255	28.613 1.1265	IR-1416 ⁽¹⁾	
0.029 0.065	—	28.575 1.1250	28.562 1.1245	34.938 1.3755	34.912 1.3745	34.912 1.3745	28.588 1.1255	28.613 1.1265	IR-1416 ⁽¹⁾	
0.035 0.078	0.040 0.088	28.575 1.1250	28.562 1.1245	34.938 1.3755	34.912 1.3745	34.912 1.3745	28.588 1.1255	28.613 1.1265	IR-1416 ⁽¹⁾	
0.047 0.104	0.054 0.118	28.575 1.1250	28.562 1.1245	34.938 1.3755	34.912 1.3745	34.912 1.3745	28.588 1.1255	28.613 1.1265	IR-1416 ⁽¹⁾	
0.056 0.123	0.063 0.138	28.575 1.1250	28.562 1.1245	38.113 1.5005	38.087 1.4995	38.087 1.4995	28.588 1.1255	28.613 1.1265	IR-1416 ⁽¹⁾	
0.074 0.164	0.084 0.186	28.575 1.1250	28.562 1.1245	38.113 1.5005	38.087 1.4995	38.087 1.4995	28.588 1.1255	28.613 1.1265	IR-1416 ⁽¹⁾	
0.093 0.205	0.105 0.232	28.575 1.1250	28.562 1.1245	38.113 1.5005	38.087 1.4995	38.087 1.4995	28.588 1.1255	28.613 1.1265		
0.040 0.088	0.045 0.099	30.163 1.1875	30.150 1.1870	38.113 1.5005	38.087 1.4995	38.087 1.4995	30.175 1.1880	30.201 1.1890		1 3/16
0.064 0.140	—	30.163 1.1875	30.150 1.1870	38.113 1.5005	38.087 1.4995	38.087 1.4995	30.175 1.1880	30.201 1.1890		
0.026 0.057	0.029 0.065	31.750 1.2500	31.737 1.2495	38.113 1.5005	38.087 1.4995	38.087 1.4995	31.763 1.2505	31.788 1.2515	IR-1612	1 1/4
0.032 0.071	0.044 0.097	31.750 1.2500	31.737 1.2495	38.113 1.5005	38.087 1.4995	38.087 1.4995	31.763 1.2505	31.788 1.2515	IR-1612	
0.039 0.086	0.045 0.099	31.750 1.2500	31.737 1.2495	38.113 1.5005	38.087 1.4995	38.087 1.4995	31.763 1.2505	31.788 1.2515	IR-1612	
0.052 0.114	0.059 0.130	31.750 1.2500	31.737 1.2495	38.113 1.5005	38.087 1.4995	38.087 1.4995	31.763 1.2505	31.788 1.2515	IR-1616 ⁽¹⁾	
0.065 0.143	0.073 0.162	31.750 1.2500	31.737 1.2495	38.113 1.5005	38.087 1.4995	38.087 1.4995	31.763 1.2505	31.788 1.2515		
0.041 0.090	0.046 0.102	31.750 1.2500	31.737 1.2495	41.288 1.6255	41.262 1.6245	41.262 1.6245	31.763 1.2505	31.788 1.2515	IR-1612	
0.061 0.135	0.069 0.153	31.750 1.2500	31.737 1.2495	41.288 1.6255	41.262 1.6245	41.262 1.6245	31.763 1.2505	31.788 1.2515	IR-1612	
0.081 0.179	0.092 0.203	31.750 1.2500	31.737 1.2495	41.288 1.6255	41.262 1.6245	41.262 1.6245	31.763 1.2505	31.788 1.2515	IR-1616 ⁽¹⁾	
0.102 0.224	0.115 0.254	31.750 1.2500	31.737 1.2495	41.288 1.6255	41.262 1.6245	41.262 1.6245	31.763 1.2505	31.788 1.2515		
0.034 0.076	0.039 0.086	33.338 1.3125	33.325 1.3120	41.288 1.6255	41.262 1.6245	41.262 1.6245	33.350 1.3130	33.378 1.3141		1 5/16
0.043 0.095	0.049 0.108	33.338 1.3125	33.325 1.3120	41.288 1.6255	41.262 1.6245	41.262 1.6245	33.350 1.3130	33.378 1.3141		
0.087 0.191	—	33.338 1.3125	33.325 1.3120	41.288 1.6255	41.262 1.6245	41.262 1.6245	33.350 1.3130	33.378 1.3141		
0.028 0.062	0.032 0.070	34.925 1.3750	34.912 1.3745	41.288 1.6255	41.262 1.6245	41.262 1.6245	34.938 1.3755	34.966 1.3766	IR-1812	1 3/8
0.043 0.094	0.049 0.107	34.925 1.3750	34.912 1.3745	41.288 1.6255	41.262 1.6245	41.262 1.6245	34.938 1.3755	34.966 1.3766	IR-1812	
0.057 0.125	0.064 0.142	34.925 1.3750	34.912 1.3745	41.288 1.6255	41.262 1.6245	41.262 1.6245	34.938 1.3755	34.966 1.3766	IR-1816	
0.071 0.156	0.080 0.177	34.925 1.3750	34.912 1.3745	41.288 1.6255	41.262 1.6245	41.262 1.6245	34.938 1.3755	34.966 1.3766	IR-1820	

⁽¹⁾ IRA inner ring provides additional length if required.

Continued on next page.



**FULL COMPLEMENT BEARINGS,
OPEN ENDS, CLOSED ONE END – continued**

INCH SERIES

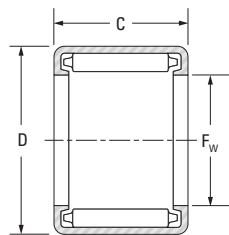

B, BH

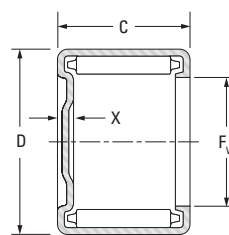

M-1, MH-1

Full Complement Bearing

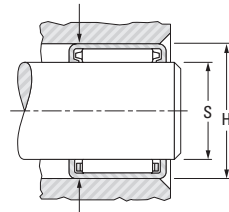

Caged Bearing

Shaft surface to be 58 HRC or equivalent

Drawn cup bearings of nominal inch dimensions, with one closed end, that are not tabulated, may be made available upon request.

Mounting dimensions are based on the inner ring rotating and the outer ring being stationary, relative to the load. The housing should be of high strength material.

See Engineering section for discussion of shaft and housing design.

Shaft Dia.	F _w	D	C		X (max.)	Bearing Designation	Load Ratings		Speed Rating		C ₉
			+0 +0.000	-0.3 -0.010			Dynamic	Static	Grease	Oil	
			mm	mm			C	C ₀			
in	mm in	mm in	mm in	mm in			kN lbf		min ⁻¹		
	34.925 1.3750	44.450 1.7500	12.70 0.500	—	BH-228	—	21.2 4770	33.5 7540	3000	4700	0.0394
	34.925 1.3750	44.450 1.7500	15.88 0.625	—	BH-2210	—	28.5 6410	48.9 11000	3000	4700	0.0432
	34.925 1.3750	44.450 1.7500	19.05 0.750	3.05 0.120	BH-2212	MH-22121	35.3 7930	64.5 14500	3000	4700	0.0463
	34.925 1.3750	44.450 1.7500	25.40 1.000	3.05 0.120	BH-2216	MH-22161	47.6 10700	94.8 21300	3000	4700	0.0509
	34.925 1.3750	44.450 1.7500	31.75 1.250	—	BH-2220	—	59.6 13400	126.0 28300	3000	4700	0.0547
1 1/2	38.100 1.5000	47.625 1.8750	12.70 0.500	3.05 0.120	B-248	M-2481	22.3 5020	37.1 8340	2800	4300	0.0420
	38.100 1.5000	47.625 1.8750	15.88 0.625	3.05 0.120	B-2410	M-24101	29.8 6710	53.8 12100	2800	4300	0.0460
	38.100 1.5000	47.625 1.8750	19.05 0.750	3.05 0.120	B-2412	M-24121	36.9 8290	70.7 15900	2800	4300	0.0493
	38.100 1.5000	47.625 1.8750	22.23 0.875	3.05 0.120	B-2414	M-24141	43.5 9780	87.6 19700	2800	4300	0.0519
	38.100 1.5000	47.625 1.8750	25.40 1.000	3.05 0.120	B-2416	M-24161	49.8 11200	103.0 23300	2800	4300	0.0542
	38.100 1.5000	47.625 1.8750	31.75 1.250	3.05 0.120	B-2420	M-24201	61.8 13900	138.0 31000	2800	4300	0.0581
1 5/8	41.275 1.6250	50.800 2.0000	12.70 0.500	—	B-268	—	22.8 5120	39.2 8820	2600	3900	0.0441
	41.275 1.6250	50.800 2.0000	15.88 0.625	3.05 0.120	B-2610	M-26101	30.6 6890	57.4 12900	2600	3900	0.0485
	41.275 1.6250	50.800 2.0000	25.40 1.000	—	B-2616	—	51.6 11600	112.0 25200	2600	3900	0.0573
	41.275 1.6250	50.800 2.0000	31.75 1.250	3.05 0.120	B-2620	M-26201	64.0 14400	149.0 33400	2600	3900	0.0614
1 3/4	44.450 1.7500	53.975 2.1250	19.05 0.750	3.05 0.120	B-2812	M-28121	39.3 8830	81.4 18300	2400	3700	0.0547
	44.450 1.7500	53.975 2.1250	25.40 1.000	3.05 0.120	B-2816	M-28161	53.4 12000	121.0 27100	2400	3700	0.0603
	44.450 1.7500	53.975 2.1250	31.75 1.250	—	B-2820	—	66.3 14900	160.0 36000	2400	3700	0.0647
	44.450 1.7500	53.975 2.1250	38.10 1.500	3.05 0.120	B-2824	M-26241	78.7 17700	199.0 44800	2400	3700	0.0683
1 7/8	47.625 1.8750	57.150 2.2500	12.70 0.500	3.05 0.120	B-308	M-3081	25.1 5650	46.3 10400	2300	3500	0.0489
	47.625 1.8750	57.150 2.2500	15.888 0.625	—	B-3010	—	33.6 7550	67.6 15200	2300	3500	0.0537
	47.625 1.8750	57.150 2.2500	19.05 0.750	—	B-3012	—	41.5 9330	88.5 19900	2300	3500	0.0574
	47.625 1.8750	57.150 2.2500	25.40 1.000	3.05 0.120	B-3016	M-30161	56.0 12600	130.0 29200	2300	3500	0.0632
2	50.800 2.0000	60.325 2.3750	12.70 0.500	3.05 0.120	B-328	M-3281	25.4 5710	48.0 10800	2100	3300	0.0509
	50.800 2.0000	60.325 2.3750	15.88 0.625	—	B-3210	—	34.2 7680	70.7 15900	2100	3300	0.0560

Approx. Wt.		S		H		Inspection			Mounting Inner Ring (pg B-120 to B-122)	Shaft Dia. in
Open Ends	Closed End	Recommended Mounting Dimension				Ring Gage	Plug Gage			
		Max.	Min.	Max.	Min.		Go	No Go		
kg lbs	kg lbs	mm in	mm in	mm in	mm in					
0.044 0.098	—	34.925 1.3750	34.912 1.3745	44.463 1.7505	44.437 1.7495	44.437 1.7495	34.938 1.3755	34.966 1.3766	IR-1812	
0.055 0.122	—	34.925 1.3750	34.912 1.3745	44.463 1.7505	44.437 1.7495	44.437 1.7495	34.938 1.3755	34.966 1.3766	IR-1812	
0.066 0.146	0.075 0.165	34.925 1.3750	34.912 1.3745	44.463 1.7505	44.437 1.7495	44.437 1.7495	34.938 1.3755	34.966 1.3766	IR-1812	
0.088 0.195	0.100 0.221	34.925 1.3750	34.912 1.3745	44.463 1.7505	44.437 1.7495	44.437 1.7495	34.938 1.3755	34.966 1.3766	IR-1816	
0.111 0.244	0.125 0.276	34.925 1.3750	34.912 1.3745	44.463 1.7505	44.437 1.7495	44.437 1.7495	34.938 1.3755	34.966 1.3766	IR-1820	
0.048 0.105	0.054 0.119	38.100 1.5000	38.087 1.4995	47.638 1.8755	47.612 1.8745	47.612 1.8745	38.113 1.5005	38.143 1.5017	IR-1916	1 1/2
0.060 0.132	0.068 0.150	38.100 1.5000	38.087 1.4995	47.638 1.8755	47.612 1.8745	47.612 1.8745	38.113 1.5005	38.143 1.5017	IR-1916	
0.072 0.158	0.081 0.179	38.100 1.5000	38.087 1.4995	47.638 1.8755	47.612 1.8745	47.612 1.8745	38.113 1.5005	38.143 1.5017	IR-1916	
0.083 0.184	0.095 0.209	38.100 1.5000	38.087 1.4995	47.638 1.8755	47.612 1.8745	47.612 1.8745	38.113 1.5005	38.143 1.5017	IR-1916	
0.096 0.211	0.108 0.239	38.100 1.5000	38.087 1.4995	47.638 1.8755	47.612 1.8745	47.612 1.8745	38.113 1.5005	38.143 1.5017	IR-1916	
0.119 0.263	0.135 0.298	38.100 1.5000	38.087 1.4995	47.638 1.8755	47.612 1.8745	47.612 1.8745	38.113 1.5005	38.143 1.5017	IR-1920	
0.051 0.113	—	41.275 1.6250	41.262 1.6245	50.813 2.0005	50.787 1.9995	50.787 1.9995	41.288 1.6255	41.318 1.6267	IR-2020 ⁽¹⁾	1 5/8
0.064 0.141	0.073 0.160	41.275 1.6250	41.262 1.6245	50.813 2.0005	50.787 1.9995	50.787 1.9995	41.288 1.6255	41.318 1.6267	IR-2020 ⁽¹⁾	
0.103 0.226	—	41.275 1.6250	41.262 1.6245	50.813 2.0005	50.787 1.9995	50.787 1.9995	41.288 1.6255	41.318 1.6267	IR-2020 ⁽¹⁾	
0.128 0.282	0.145 0.320	41.275 1.6250	41.262 1.6245	50.813 2.0005	50.787 1.9995	50.787 1.9995	41.288 1.6255	41.318 1.6267	IR-2220 ⁽¹⁾	
0.082 0.181	0.093 0.205	44.450 1.7500	44.437 1.7495	53.988 2.1255	53.962 2.1245	53.962 2.1245	44.463 1.7505	44.496 1.7518	IR-2316	1 3/4
0.110 0.242	0.124 0.274	44.450 1.7500	44.437 1.7495	53.988 2.1255	53.962 2.1245	53.962 2.1245	44.463 1.7505	44.496 1.7518	IR-2316	
0.137 0.302	—	44.450 1.7500	44.437 1.7495	53.988 2.1255	53.962 2.1245	53.962 2.1245	44.463 1.7505	44.496 1.7518	IR-2324	
0.165 0.363	0.186 0.411	44.450 1.7500	44.437 1.7495	53.988 2.1255	53.962 2.1245	53.962 2.1245	44.463 1.7505	44.496 1.7518	IR-2324	
0.059 0.129	0.066 0.146	47.625 1.8750	47.612 1.8745	57.163 2.2505	57.137 2.2495	57.137 2.2495	47.638 1.8755	47.671 1.8768		1 7/8
0.073 0.161	—	47.625 1.8750	47.612 1.8745	57.163 2.2505	57.137 2.2495	57.137 2.2495	47.638 1.8755	47.671 1.8768		
0.088 0.193	—	47.625 1.8750	47.612 1.8745	57.163 2.2505	57.137 2.2495	57.137 2.2495	47.638 1.8755	47.671 1.8768		
0.117 0.258	0.132 0.292	47.625 1.8750	47.612 1.8745	57.163 2.2505	57.137 2.2495	57.137 2.2495	47.638 1.8755	47.671 1.8768		
0.062 0.136	0.070 0.154	50.800 2.0000	50.785 1.9994	60.338 2.3755	60.312 2.3745	60.312 2.3745	50.815 2.0006	50.848 2.0019		2
0.078 0.171	—	50.800 2.0000	50.785 1.9994	60.335 2.3755	60.312 2.3745	60.312 2.3745	50.815 2.0006	50.848 2.0019		

⁽¹⁾ IRA inner ring provides additional length if required.

Continued on next page.



FULL COMPLEMENT BEARINGS,
OPEN ENDS, CLOSED ONE END – continued

INCH SERIES

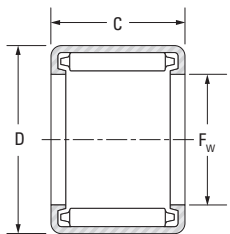

B, BH

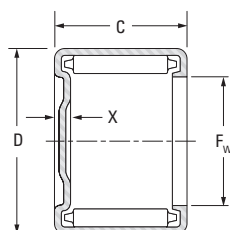

M-1, MH-1

Full Complement Bearing

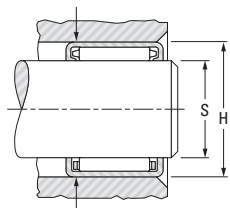

Caged Bearing

Shaft surface to be 58 HRC or equivalent

Drawn cup bearings of nominal inch dimensions, with one closed end, that are not tabulated, may be made available upon request.

Mounting dimensions are based on the inner ring rotating and the outer ring being stationary, relative to the load. The housing should be of high strength material.

See Engineering section for discussion of shaft and housing design.

Shaft Dia.	F _w	D	C		X (max.)	Bearing Designation	Load Ratings		Speed Rating		C ₉
			+0 +0.000	-0.3 -0.010			Dynamic	Static	Grease	Oil	
			mm	mm			C	C ₀			
in	mm in	mm in	mm in	mm in			kN lbf		min ⁻¹		
	50.800 2.0000	60.325 2.3750	22.23 0.875	—	B-3214	—	54.3 11300	115.0 26000	2100	3300	0.0632
	50.800 2.0000	60.325 2.3750	25.40 1.000	3.05 0.120	B-3216	M-32161	57.4 12900	138.0 31000	2100	3300	0.0661
	50.800 2.0000	60.325 2.3750	31.75 1.250	3.05 0.120	B-3220	M-32201	71.6 16100	183.0 41100	2100	3300	0.0708
	50.800 2.0000	60.325 2.3750	38.10 1.500	3.05 0.120	B-3224	M-32241	85.0 19100	228.0 51200	2100	3300	0.0748
	50.800 2.0000	60.325 2.3750	44.45 1.750	3.05 0.120	B-3228	M-32281	97.4 21900	273.0 61300	2100	3300	0.0782
2 1/16	52.388 2.0625	64.292 2.5312	19.05 0.750	—	BH-3312	—	46.3 10400	86.7 19500	2600	4100	0.0574
	52.388 2.0625	64.292 2.5312	25.40 1.000	3.56 0.140	BH-3316	MH-33161	64.0 14400	133.0 29900	2600	4100	0.0639
	52.388 2.0625	64.292 2.5312	38.10 1.500	3.56 0.140	BH-3324	MH-33241	97.0 21800	226.0 50700	2600	4100	0.0728
2 1/8	53.975 2.1250	63.500 2.5000	12.70 0.500	—	B-348	—	26.1 5870	51.2 11500	2000	3100	0.0531
	53.975 2.1250	63.500 2.5000	19.05 0.750	—	B-3412	—	43.6 9790	99.2 22300	2000	3100	0.0626
	53.975 2.1250	63.500 2.5000	25.40 1.000	3.05 0.120	B-3416	M-34161	59.2 13300	147.0 33000	2000	3100	0.0690
	53.975 2.1250	63.500 2.5000	31.75 1.250	—	B-3420	—	73.4 16500	194.0 43700	2000	3100	0.0740
	53.975 2.1250	63.500 2.5000	38.10 1.500	3.05 0.120	B-3424	M-34241	87.2 19600	242.0 54400	2000	3100	0.0781
2 1/4	57.150 2.2500	66.675 2.6250	19.05 0.750	3.30 0.130	B-3612	M-36121	45.8 10300	105.0 23700	2000	3000	0.0648
	57.150 2.2500	66.675 2.6250	25.40 1.000	—	B-3616	—	62.2 14000	155.6 35000	2000	3000	0.0715
	57.150 2.2500	66.675 2.6250	31.75 1.250	—	B-3620	—	77.4 17400	206.0 46400	2000	3000	0.0766
	57.150 2.2500	66.675 2.6250	38.10 1.500	3.30 0.130	B-3624	M-36241	92.1 20700	257.0 57700	2000	3000	0.0809
2 5/8	66.675 2.6250	76.200 3.0000	25.40 1.000	3.30 0.130	B-4216	M-42161	66.7 15000	182.0 40900	1700	2500	0.0799
2 3/4	69.850 2.7500	79.375 3.1250	15.88 0.625	—	B-4410	—	41.0 9210	98.0 22000	1600	2500	0.0698
	69.850 2.7500	79.375 3.1250	19.050 0.7500	—	B-4412	—	50.7 11400	129.0 29000	1600	2500	0.0747
	69.850 2.7500	79.375 3.1250	25.40 1.000	—	B-4416	—	69.0 15500	190.0 42800	1600	2500	0.0824
	69.850 2.7500	79.375 3.1250	31.75 1.250	3.30 0.130	B-4420	M-44201	85.4 19200	252.0 56700	1600	2500	0.0883
3 1/2	88.900 3.5000	101.600 4.0000	19.05 0.750	—	B-5612	—	64.9 14600	150.0 33700	1800	2700	0.0819
5 1/2	139.700 5.5000	152.400 6.0000	19.05 0.750	—	B-8812	—	77.0 17300	231.0 52000	1000	1600	0.1140

Approx. Wt.		S		H		Inspection		Mounting Inner Ring (pg B-120 to B-122)	Shaft Dia. in	
Open Ends	Closed End	Recommended Mounting Dimension				Ring Gage	Plug Gage			
		Max.	Min.	Max.	Min.		Go			No Go
kg lbs	kg lbs	mm in	mm in	mm in	mm in					
0.108 0.239	—	50.800 2.0000	50.785 1.9994	60.338 2.3755	60.312 2.3745	60.312 2.3745	50.815 2.0006	50.848 2.0019		
0.124 0.273	0.140 0.309	50.800 2.0000	50.785 1.9994	60.338 2.3755	60.312 2.3745	60.312 2.3745	50.815 2.0006	50.848 2.0019		
0.155 0.341	0.175 0.386	50.800 2.0000	50.785 1.9994	60.338 2.3755	60.312 2.3745	60.312 2.3745	50.815 2.0006	50.848 2.0019		
0.186 0.410	0.211 0.465	50.800 2.0000	50.785 1.9994	60.338 2.3755	60.312 2.3745	60.312 2.3745	50.815 2.0006	50.848 2.0019		
0.217 0.478	0.245 0.541	50.800 2.0000	50.785 1.9994	60.338 2.3755	60.312 2.3745	60.312 2.3745	50.815 2.0006	50.848 2.0019		
0.122 0.269	—	52.388 2.0625	52.372 2.0619	64.305 2.5317	64.280 2.5307	64.280 2.5307	52.413 2.0635	52.451 2.0650	IR-2916	
0.162 0.358	0.184 0.406	52.388 2.0625	52.372 2.0619	64.305 2.5317	64.280 2.5307	64.280 2.5307	52.413 2.0635	52.451 2.0650	IR-2916	
0.244 0.537	0.276 0.609	52.388 2.0625	52.372 2.0619	64.305 2.5317	64.280 2.5307	64.280 2.5307	52.413 2.0635	52.451 2.0650	IR-2924	
0.065 0.144	—	53.975 2.1250	53.960 2.1244	63.513 2.5005	63.487 2.4995	63.487 2.4995	53.990 2.1256	54.028 2.1271	IR-3024	
0.098 0.216	—	53.975 2.1250	53.960 2.1244	63.513 2.5005	63.487 2.4995	63.487 2.4995	53.990 2.1256	54.028 2.1271	IR-3024	
0.131 0.289	0.148 0.327	53.975 2.1250	53.960 2.1244	63.513 2.5005	63.487 2.4995	63.487 2.4995	53.990 2.1256	54.028 2.1271	IR-3024	
0.164 0.361	—	53.975 2.1250	53.960 2.1244	63.513 2.5005	63.487 2.4995	63.487 2.4995	53.990 2.1256	54.028 2.1271	IR-3024	
0.196 0.433	0.223 0.491	53.975 2.1250	53.960 2.1244	63.513 2.5005	63.487 2.4995	63.487 2.4995	53.990 2.1256	54.028 2.1271	IR-3024	
0.103 0.228	0.117 0.258	57.150 2.2500	57.135 2.2494	66.688 2.6255	66.662 2.6245	66.662 2.6245	57.165 2.2506	57.203 2.2521	2 1/4	
0.138 0.304	—	57.150 2.2500	57.135 2.2494	66.688 2.6255	66.662 2.6245	66.662 2.6245	57.165 2.2506	57.203 2.2521		
0.172 0.380	—	57.150 2.2500	57.135 2.2494	66.688 2.6255	66.662 2.6245	66.662 2.6245	57.165 2.2506	57.203 2.2521		
0.207 0.456	0.235 0.517	57.150 2.2500	57.135 2.2494	66.688 2.6255	66.662 2.6245	66.662 2.6245	57.165 2.2506	57.203 2.2521		
0.159 0.351	0.181 0.398	66.675 2.6250	66.660 2.6244	76.213 3.0005	76.187 2.9995	76.187 2.9995	66.700 2.6260	66.739 2.6275	2 5/8	
0.104 0.229	—	69.850 2.7500	69.835 2.7494	79.388 3.1255	79.362 3.1245	79.362 3.1245	69.875 2.7510	69.914 2.7525	IR-4016	
0.124 0.274	—	69.850 2.7500	69.835 2.7494	79.388 3.1255	79.362 3.1245	79.362 3.1245	69.875 2.7510	69.914 2.7525	IR-4016	
0.166 0.366	—	69.850 2.7500	69.835 2.7494	79.388 3.1255	79.362 3.1245	79.362 3.1245	69.875 2.7510	69.914 2.7525	IR-4016	
0.208 0.458	0.235 0.519	69.850 2.7500	69.835 2.7494	79.388 3.1255	79.362 3.1245	79.362 3.1245	69.875 2.7510	69.914 2.7525		
0.212 0.468	—	88.900 3.5000	88.885 3.4994	101.613 4.0005	101.587 3.9995	101.587 3.9995	88.925 3.5010	88.964 3.5025	3 1/2	
0.325 0.717	—	139.700 5.5000	139.682 5.4993	152.425 6.0010	152.375 5.9990	152.375 5.9990	139.725 5.5010	139.776 5.5030	5 1/2	



EXTRA-PRECISION BEARINGS

INCH SERIES

Open-end full-complement mechanically retained drawn cup needle roller bearings, manufactured to inch standards, are offered with extra-precision specifications. The manufacturing tolerance of these bearings is one-third that of the standard precision bearings. In production operations, using closer tolerances on shaft and housing, they will assemble with consistently lower radial internal clearances than can be expected with the standard precision series bearings.

Extra-precision bearings are suitable for those applications requiring close control of radial play and eccentricity. They are also preferred when two bearings are mounted adjacent to each other because greater accuracy in manufacture will provide better load distribution between the bearings.

Nominal dimensions, load ratings, speed ratings and other general specifications for extra-precision bearings are the same as for the corresponding "B" or "BH" sizes of drawn cup needle roller bearings. Consequently, the data on pages B-92 to B-105 can be used in bearing size selection.

When ordering an extra-precision bearing, add the prefix letter "G" to the bearing designation. For example, after following the size selection procedure outlined in the engineering section, bearing B-1212 is selected – but extra-precision tolerances are required. These are designated by ordering a GB-1212 bearing.

To realize the advantages of the expected closer radial internal clearance of the extra-precision bearing, the user must have the capability of producing housing bore and shaft raceway diameters to the close tolerances indicated by the bearing tables on page B-108.

The resulting total radial internal clearance, within the installed GB-1212 extra-precision drawn cup needle roller bearing, will lie in the range from 0.005 mm to 0.030 mm (0.0002 in to 0.0012 in)

Inspection dimensions for the extra-precision bearings are given in Table B-13 on page B-107. Note that these bearings must be inspected while mounted in the specified ring gage. Bearing bores are checked with "go" and "no go" plug gages. The "go" gage size is the minimum diameter inside the needle rollers. The "no go" gage size is 0.002 mm (0.0001 in) larger than the maximum diameter inside the needle rollers.

Procedures for selecting ring and plug gage dimensions are the same as for those involving standard precision needle roller bearings – except that the ring gage diameters and diameters inside the needle rollers must be drawn from the table on page B-107.

Table B-13. Inspection for extra-precision drawn cup needle roller bearings – inch series

Table with 4 columns: Nominal shaft diameter, Ring gage, Diameter inside needle rollers (Max., Min.), and their corresponding values in mm and inches for various bearing sizes.



Table B-14. Mounting dimensions for extra-precision drawn cup needle roller bearings – inch series

Bearing bore designation	Mounting					
	Nominal bore	Nominal O.D.	Shaft raceway diameter		Housing bore	
			Max.	Min.	Max.	Min.
mm in	mm in	mm in	mm in	mm in	mm in	
GB-2	3.175 0.1250	6.350 0.2500	3.178 0.1251	3.170 0.1248	6.281 0.2473	6.274 0.2470
GB-2 1/2	3.967 0.1562	7.142 0.2812	3.973 0.1564	3.965 0.1561	7.074 0.2785	7.066 0.2782
GB-3	4.763 0.1875	8.733 0.3438	4.765 0.1876	4.757 0.1873	8.611 0.3390	8.603 0.3387
GB-4	6.350 0.2500	11.113 0.4375	6.353 0.2501	6.345 0.2498	10.993 0.4328	10.986 0.4325
GB-5	7.938 0.3125	12.700 0.5000	7.940 0.3126	7.932 0.3123	12.581 0.4953	12.573 0.4950
GBH-5	7.938 0.3125	14.288 0.5625	7.940 0.3126	7.932 0.3123	14.168 0.5578	14.161 0.5575
GB-6	9.525 0.3750	14.288 0.5625	9.528 0.3751	9.520 0.3748	14.168 0.5578	14.161 0.5575
GBH-6	9.525 0.3750	15.875 0.6250	9.528 0.3751	9.520 0.3748	15.756 0.6203	15.748 0.6200
GB-7	11.113 0.4375	15.875 0.6250	11.115 0.4376	11.107 0.4373	15.756 0.6203	15.748 0.6200
GBH-7	11.113 0.4375	17.463 0.6875	11.115 0.4376	11.107 0.4373	17.343 0.6828	17.336 0.6825
GB-8	12.700 0.5000	17.463 0.6875	12.703 0.5001	12.695 0.4998	17.343 0.6828	17.336 0.6825
GBH-8	12.700 0.5000	19.050 0.7500	12.703 0.5001	12.695 0.4998	18.931 0.7453	18.923 0.7450
GB-9	14.288 0.5625	19.050 0.7500	14.290 0.5626	14.282 0.5623	18.931 0.7453	18.923 0.7450
GBH-9	14.288 0.5625	20.638 0.8125	14.290 0.5626	14.282 0.5623	20.518 0.8078	20.511 0.8075
GB-10	15.875 0.6250	20.638 0.8125	14.878 0.6251	15.870 0.6248	20.518 0.8078	20.511 0.8075
GBH-10	15.875 0.6250	22.225 0.8750	14.878 0.6251	15.870 0.6248	22.106 0.8703	22.098 0.8700
GB-11	17.463 0.6875	22.225 0.8750	17.465 0.6876	17.457 0.6873	22.106 0.8703	22.098 0.8700
GBH-11	17.463 0.6875	23.813 0.9375	17.465 0.6876	17.457 0.6873	23.693 0.9328	23.686 0.9325
GB-12	19.050 0.7500	25.400 1.0000	19.053 0.7501	19.045 0.7498	25.281 0.9953	25.273 0.9950
GBH-12	19.050 0.7500	26.988 1.0625	19.053 0.7501	19.045 0.7498	26.868 1.0578	26.861 1.0575
GB-13	20.638 0.8125	26.988 1.0625	20.640 0.8126	20.632 0.8123	26.868 1.0578	26.861 1.0575
GBH-13	20.638 0.8125	28.575 1.1250	20.640 0.8126	20.632 0.8123	28.456 1.1203	28.448 1.1200
GB-14	22.225 0.8750	28.575 1.1250	22.228 0.8751	22.220 0.8748	28.456 1.1203	28.448 1.1200
GBH-14	22.225 0.8750	30.163 1.1875	22.228 0.8751	22.220 0.8748	30.046 1.1829	30.036 1.1825
GB-15	23.813 0.9375	30.163 1.1875	23.815 0.9376	23.807 0.9373	30.046 1.1829	30.036 1.1825
GB-16	25.400 1.0000	31.750 1.2500	25.403 1.0001	25.395 0.9998	31.633 1.2454	31.623 1.2450
GBH-16	25.400 1.0000	33.338 1.3125	25.403 1.0001	25.395 0.9998	33.221 1.3079	33.211 1.3075
GB-17	26.988 1.0625	33.338 1.3125	26.990 1.0626	26.982 1.0623	33.221 1.3079	33.211 1.3075
GB-18	28.575 1.1250	34.925 1.3750	28.578 1.1251	28.570 1.1248	34.808 1.3704	34.798 1.3700
GBH-18	28.575 1.1250	38.100 1.5000	28.578 1.1251	28.570 1.1248	37.986 1.4955	37.973 1.4950
GB-19	30.163 1.1875	38.100 1.5000	30.165 1.1876	30.157 1.1873	37.986 1.4955	37.973 1.4950
GB-20	31.750 1.2500	38.100 1.5000	31.753 1.2501	31.745 1.2498	37.986 1.4955	37.973 1.4950
GBH-20	31.750 1.2500	41.275 1.6250	31.753 1.2501	31.745 1.2498	41.161 1.6205	41.148 1.6200
GB-21	33.338 1.3125	41.275 1.6250	33.340 1.3126	33.332 1.3123	41.161 1.6205	41.148 1.6200
GB-22	34.925 1.3750	41.275 1.6250	34.925 1.3750	34.917 1.3747	41.161 1.6205	41.148 1.6200
GBH-22	34.925 1.3750	44.450 1.7500	34.925 1.3750	34.917 1.3747	44.336 1.7455	44.323 1.7450
GB-24	38.100 1.5000	47.625 1.8750	38.100 1.5000	38.092 1.4997	47.511 1.8705	47.498 1.8700
GB-26	41.275 1.6250	50.800 2.0000	41.275 1.6250	41.267 1.6247	50.686 1.9955	50.673 1.9950
GB-28	44.450 1.7500	53.975 2.1250	44.450 1.7500	44.442 1.7497	53.861 2.1205	53.848 2.1200
GB-30	47.625 1.8750	57.150 2.2500	47.625 1.8750	47.617 1.8747	57.036 2.2455	57.023 2.2450
GB-32	50.800 2.0000	60.325 2.3750	50.800 2.0000	50.792 1.9997	60.211 2.3705	60.198 2.3700
GBH-33	52.388 2.0625	64.293 2.5312	52.385 2.0624	52.377 2.0621	64.178 2.5267	64.166 2.5262
GB-34	53.975 2.1250	63.500 2.5000	53.973 2.1249	53.965 2.1246	63.386 2.4955	63.373 2.4950
GB-36	57.150 2.2500	66.675 2.6250	57.148 2.2499	57.140 2.2496	66.561 2.6205	66.548 2.6200
GB-42	66.675 2.6250	76.200 3.0000	66.670 2.6248	66.662 2.6245	76.088 2.9956	76.073 2.9950
GB-44	69.850 2.7500	79.375 3.1250	69.848 2.7498	69.837 2.7495	79.263 3.1206	79.248 3.1200
GB-56	88.900 3.5000	101.600 4.0000	88.895 3.4998	88.887 3.4995	101.488 3.9956	101.473 3.9950

NOTE

Check for availability as not every size may be in production.

NOTES



CAGED BEARINGS – OPEN ENDS, CLOSED ONE END

INCH SERIES

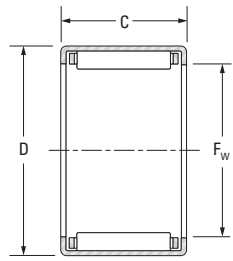

J, JH

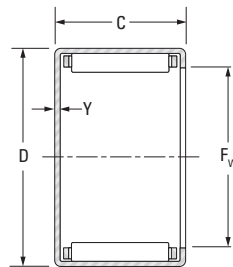

MJ-1, MJH-1

Full Complement Bearing

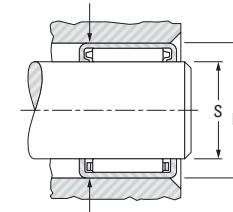

Caged Bearing

Shaft surface to be 58 HRC or equivalent

Drawn cup bearings of nominal inch dimensions, with one closed end, that are not tabulated, may be made available upon request.

Mounting dimensions are based on the inner ring rotating and the outer ring being stationary, relative to the load. The housing should be of high strength material.

See Engineering section for discussion of shaft and housing design.

Shaft Dia.	F _w	D	C		Y (max.)	Bearing Designation	Load Ratings		Speed Rating		C _g
			+0 +0.000	-0.3 -0.010			Dynamic	Static	Grease	Oil	
			mm	mm			C	C ₀			
in	mm	mm	mm	mm	mm		kN	lbf	min ⁻¹		
1/8	3.175 0.1250	6.350 0.2500	4.78 0.188	—	—	JP-23-F	0.89 200	0.62 140	33000	51000	0.0064
	3.175 0.1250	6.350 0.2500	6.35 0.250	—	—	JP-24-F	1.33 300	1.02 230	33000	51000	0.0072
5/32	3.970 0.1563	7.142 0.2812	4.78 0.188	—	—	JP-2 1/2 3F	0.93 210	0.62 140	31000	47000	0.0070
3/16	4.763 0.1875	8.733 0.3438	4.77 0.188	—	—	JP-33-F	1.07 240	0.71 160	25000	38000	0.0076
	4.763 0.1875	8.733 0.3438	6.35 0.250	—	—	JP-34-F	1.60 360	1.25 280	25000	38000	0.0087
	4.763 0.1875	8.733 0.3438	9.53 0.375	1.02 0.040	—	J-36	2.27 510	1.91 430	25000	38000	0.0097
1/4	6.350 0.2500	11.113 0.4375	7.92 0.312	1.02 0.040	—	J-45	2.22 500	1.73 390	20000	30000	0.0103
	6.350 0.2500	11.113 0.4375	11.13 0.438	1.02 0.040	—	J-47	3.38 760	3.02 680	20000	30000	0.0119
5/16	7.938 0.3125	12.700 0.5000	7.92 0.312	—	—	J-55	2.40 540	2.00 450	18000	28000	0.0117
	7.938 0.3125	12.700 0.5000	11.13 0.438	1.02 0.040	—	J-57	4.05 910	3.91 880	18000	28000	0.0130
	7.938 0.3125	14.288 0.5625	11.13 0.438	1.02 0.040	—	JH-57	4.63 1040	3.78 850	14000	22000	0.0132
3/8	9.525 0.3750	14.288 0.5625	7.92 0.312	1.02 0.040	—	J-65	2.76 620	2.49 560	18000	27000	0.0133
	9.525 0.3750	14.288 0.5625	9.53 0.375	1.02 0.040	—	J-66	3.51 790	3.47 780	18000	27000	0.0144
	9.525 0.3750	14.288 0.5625	12.70 0.500	1.02 0.040	—	J-68	5.20 1170	5.74 1290	18000	27000	0.0163
	9.525 0.3750	15.875 0.6250	12.70 0.500	—	—	JH-68	6.58 1480	6.09 1370	13000	20000	0.0159
7/16	11.113 0.4375	15.875 0.6250	12.70 0.500	1.02 0.040	—	J-78	6.36 1430	7.70 1730	17000	26000	0.0187
	11.113 0.4375	17.463 0.6875	12.70 0.500	—	—	JH-78	7.12 1600	6.89 1550	13000	19000	0.0174
1/2	12.700 0.5000	17.463 0.6875	7.92 0.312	1.02 0.040	—	J-85	3.47 780	3.65 820	16000	25000	0.0164
	12.700 0.5000	17.463 0.6875	9.53 0.375	1.02 0.040	—	J-86	4.67 1050	5.38 1210	16000	25000	0.0181
	12.700 0.5000	17.463 0.6875	12.70 0.500	1.02 0.040	—	J-88	6.32 1420	7.92 1780	16000	25000	0.0199
	12.700 0.5000	17.463 0.6875	19.05 0.750	—	—	J-812	10.23 2300	14.72 3310	16000	25000	0.0232
	12.700 0.5000	19.050 0.7500	11.13 0.438	1.02 0.040	—	JH-87	6.41 1440	6.18 1390	12000	19000	0.0179
	12.700 0.5000	19.050 0.7500	12.70 0.500	1.02 0.040	—	JH-88	7.56 1700	7.70 1730	12000	19000	0.0189

Approx. Wt.		S		H		Inspection			Mounting Inner Ring (pg B-120 to B-122)	Shaft Dia. in
Open Ends	Closed End	Recommended Mounting Dimension				Ring Gage	Plug Gage			
		Max.	Min.	Max.	Min.		go	no go		
kg lbs	kg lbs	mm in	mm in	mm in	mm in					
0.001 0.001	—	3.175 0.1250	3.167 0.1247	6.363 0.2505	6.350 0.2500	6.363 0.2505	3.195 0.1258	3.221 0.1268		1/8
0.001 0.001	—	3.175 0.1250	3.167 0.1247	6.363 0.2505	6.350 0.2500	6.363 0.2505	3.195 0.1258	3.221 0.1268		
0.001 0.001	—	3.970 0.1563	3.962 0.1560	7.155 0.2817	7.142 0.2812	7.155 0.2817	3.990 0.1571	4.016 0.1581		5/32
0.001 0.002	—	4.763 0.1875	4.755 0.1872	8.730 0.3437	8.717 0.3432	8.730 0.3437	4.783 0.1883	4.808 0.1893		3/16
0.001 0.002	—	4.763 0.1875	4.755 0.1872	8.730 0.3437	8.717 0.3432	8.730 0.3437	4.783 0.1883	4.808 0.1893		3/16
0.002 0.004	0.002 0.005	4.763 0.1875	4.755 0.1872	8.730 0.3437	8.717 0.3432	8.730 0.3437	4.783 0.1883	4.808 0.1893		
0.003 0.006	0.003 0.007	6.350 0.2500	6.337 0.2495	11.125 0.4380	11.100 0.4370	11.125 0.4380	6.388 0.2515	6.414 0.2525		1/4
0.004 0.008	0.004 0.009	6.350 0.2500	6.337 0.2495	11.125 0.4380	11.100 0.4370	11.125 0.4380	6.388 0.2515	6.414 0.2525		
0.003 0.007	—	7.938 0.3125	7.925 0.3120	12.713 0.5005	12.687 0.4995	12.713 0.5005	7.976 0.3140	8.001 0.3150		5/16
0.004 0.009	0.005 0.011	7.938 0.3125	7.925 0.3120	12.713 0.5005	12.687 0.4995	12.713 0.5005	7.976 0.3140	8.001 0.3150		
0.006 0.013	0.007 0.016	7.938 0.3125	7.925 0.3120	14.300 0.5630	14.275 0.5620	14.300 0.5630	7.976 0.3140	8.001 0.3150		
0.004 0.008	0.004 0.009	9.525 0.3750	9.512 0.3745	14.300 0.5630	14.275 0.5620	14.300 0.5630	9.563 0.3765	9.589 0.3775	IRA-3	3/8
0.004 0.009	0.005 0.010	9.525 0.3750	9.512 0.3745	14.300 0.5630	14.275 0.5620	14.300 0.5630	9.563 0.3765	9.589 0.3775	IRA-3	
0.005 0.012	0.006 0.013	9.525 0.3750	9.512 0.3745	14.300 0.5630	14.275 0.5620	14.300 0.5630	9.563 0.3765	9.589 0.3775	IRA-3	
0.008 0.017	—	9.525 0.3750	9.512 0.3745	15.888 0.6255	15.862 0.6245	15.888 0.6255	9.563 0.3765	9.589 0.3775	IRA-3	
0.006 0.014	0.007 0.016	11.113 0.4375	11.100 0.4370	15.888 0.6255	15.862 0.6245	15.888 0.6255	11.151 0.4390	11.176 0.4400		7/16
0.009 0.019	—	11.113 0.4375	11.100 0.4370	17.475 0.6880	17.450 0.6870	17.475 0.6880	11.151 0.4390	11.176 0.4400		
0.005 0.010	0.005 0.012	12.700 0.5000	12.687 0.4995	17.475 0.6880	17.450 0.6870	17.475 0.6880	12.738 0.5015	12.764 0.5025	IRA-5	1/2
0.005 0.011	0.006 0.013	12.700 0.5000	12.687 0.4995	17.475 0.6880	17.450 0.6870	17.475 0.6880	12.738 0.5015	12.764 0.5025	IRA-5	
0.007 0.015	0.008 0.018	12.700 0.5000	12.687 0.4995	17.475 0.6880	17.450 0.6870	17.475 0.6880	12.738 0.5015	12.764 0.5025	IRA-5	
0.010 0.023	—	12.700 0.5000	12.687 0.4995	17.475 0.6880	17.450 0.6870	17.475 0.6880	12.738 0.5015	12.764 0.5025		
0.009 0.019	0.010 0.023	12.700 0.5000	12.687 0.4995	19.063 0.7505	19.037 0.7495	19.063 0.7505	12.738 0.5015	12.764 0.5025	IRA-5	
0.010 0.022	0.012 0.026	12.700 0.5000	12.687 0.4995	19.063 0.7505	19.037 0.7495	19.063 0.7505	12.738 0.5015	12.764 0.5025	IRA-5	

Continued on next page.



CAGED BEARINGS –
OPEN ENDS, CLOSED ONE END – continued

INCH SERIES

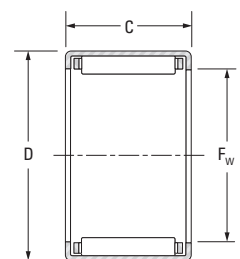

J, JH

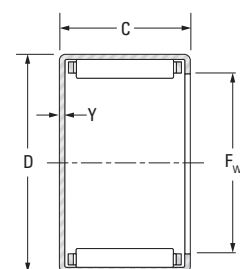

MJ-1, MJH-1

Full Complement Bearing

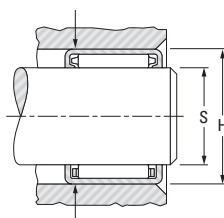

Caged Bearing

Shaft surface to be
58 HRC or equivalent

Drawn cup bearings of
nominal inch dimensions,
with one closed end,
that are not tabulated,
may be made available
upon request.

Mounting dimensions are
based on the inner ring
rotating and the outer ring
being stationary,
relative to the load.
The housing should be of
high strength material.

See Engineering section
for discussion of shaft
and housing design.

Shaft Dia.	F _w	D	C		Y (max.)	Bearing Designation	Load Ratings		Speed Rating		C _g
			+0 +0.000	-0.3 -0.010			Dynamic	Static	Grease	Oil	
			mm in	mm in			C	C ₀			
in	mm in	mm in	mm in	mm in			kN lbf		min ⁻¹		
	12.700 0.5000	19.050 0.7500	19.05 0.750	—	JH-812	—	12.32 2770	14.41 3240	12000	19000	0.0221
9/16	14.288 0.5625	19.050 0.750	11.13 0.438	1.02 0.040	J-97	MJ-971	5.47 1230	6.81 1530	16000	25000	0.0201
	14.288 0.5625	19.050 0.7500	12.70 0.500	1.02 0.040	J-98	MJ-981	6.23 1400	8.01 1800	16000	25000	0.0210
	14.288 0.5625	19.050 0.7500	15.88 0.625	—	J-910	—	5.83 1310	7.21 1620	16000	25000	0.0205
	14.288 0.5625	20.638 0.8125	12.70 0.500	1.02 0.040	JH-98	MJH-981	8.01 1800	8.50 1910	12000	18000	0.0203
5/8	15.875 0.6250	20.638 0.8125	12.70 0.500	1.02 0.040	J-108	MJ-1081	6.72 1510	9.12 2050	13000	21000	0.0227
	15.875 0.6250	20.638 0.8125	15.88 0.625	1.02 0.040	J-1010	MJ-10101	8.81 1980	12.94 2910	13000	21000	0.0247
	15.875 0.6250	20.638 0.8125	19.05 0.750	1.02 0.040	J-1012	MJ-10121	11.74 2640	18.86 4240	13000	21000	0.0272
	15.875 0.6250	22.212 0.8745	15.88 0.625	1.02 0.040	JH-1010	MJH-10101	11.57 2600	14.10 3170	14000	21000	0.0240
	15.875 0.6250	22.212 0.8745	25.40 1.000	1.02 0.040	JH-1016	MJH-10161	19.79 4450	28.11 6320	14000	21000	0.0285
11/16	17.463 0.6875	22.212 0.8745	19.05 0.750	1.02 0.040	J-1112	MJ-11121	12.46 2800	20.91 4700	12000	19000	0.0290
	17.463 0.6875	23.813 0.9375	15.88 0.625	1.02 0.040	JH-1110	MJH-11101	12.05 2710	15.21 3420	13000	19000	0.0255
	17.463 0.6875	23.813 0.9375	19.05 0.750	—	JH-1112	—	16.15 3630	22.20 4990	13000	19000	0.0280
3/4	19.050 0.7500	25.400 1.0000	9.53 0.375	—	J-126	—	6.49 1460	7.03 1580	11000	18000	0.0218
	19.050 0.7500	25.400 1.0000	12.70 0.500	—	J-128	—	9.92 2230	12.19 2740	11000	18000	0.0250
	19.050 0.7500	25.400 1.0000	15.88 0.625	1.02 0.040	J-1210	MJ-12101	12.50 2810	16.32 3670	11000	18000	0.0269
	19.050 0.7500	25.400 1.0000	19.05 0.750	1.02 0.040	J-1212	MJ-12121	15.52 3490	21.62 4860	11000	18000	0.0288
	19.050 0.7500	26.988 1.0625	19.05 0.750	1.02 0.040	JH-1212	MJH-12121	19.08 4290	23.58 5300	12000	18000	0.0285
13/16	20.638 0.8125	26.988 1.0625	22.23 0.875	—	J-1314	—	19.31 4340	29.31 6590	10000	16000	0.0321
	20.638 0.8125	28.575 1.1250	19.05 0.750	1.27 0.050	JH-1312	MJH-13121	18.77 4220	24.55 5520	11000	16000	0.0299
7/8	22.225 0.8750	28.575 1.1250	9.53 0.375	—	J-146	—	7.21 1620	8.41 1890	9700	15000	0.0243
	22.225 0.8750	28.575 1.1250	12.70 0.500	—	J-148	—	10.94 2460	14.50 3260	9700	15000	0.0270
	22.225 0.8750	28.575 1.1250	19.05 0.750	1.02 0.040	J-1412	MJ-14121	17.88 4020	27.18 6110	9700	15000	0.0325

Approx. Wt.		S		H		Inspection		Mounting Inner Ring (pg B-120 to B-122)	Shaft Dia.	
Open Ends	Closed End	Recommended Mounting Dimension				Ring Gage	Plug Gage			
		Max.	Min.	Max.	Min.		go			no go
kg lbs	kg lbs	mm in	mm in	mm in	mm in				in	
0.015 0.032	—	12.700 0.5000	12.687 0.4995	19.063 0.7505	19.037 0.7495	19.063 0.7505	12.738 0.5015	12.764 0.5025		
0.007 0.016	0.009 0.019	14.288 0.5625	14.275 0.5620	19.063 0.7505	19.037 0.7495	19.063 0.7505	14.326 0.5640	14.351 0.5650	IR-68 9/16	
0.008 0.017	0.009 0.020	14.288 0.5625	14.275 0.5620	19.063 0.7505	19.037 0.7495	19.063 0.7505	14.326 0.5640	14.351 0.5650	IR-68	
0.010 0.021	—	14.288 0.5625	14.275 0.5620	19.063 0.7505	19.037 0.7495	19.063 0.7505	14.326 0.5640	14.351 0.5650	IR-612 ⁽¹⁾	
0.011 0.025	0.014 0.030	14.288 0.5625	14.275 0.5620	20.650 0.8130	20.625 0.8120	20.650 0.8130	14.326 0.5640	14.351 0.5650	IR-68	
0.009 0.019	0.010 0.023	15.875 0.6250	15.862 0.6245	20.650 0.8130	20.625 0.8120	20.650 0.8130	15.913 0.6265	15.939 0.6275	IR-68-1 5/8	
0.010 0.023	0.013 0.028	15.875 0.6250	15.862 0.6245	20.650 0.8130	20.625 0.8120	20.650 0.8130	15.913 0.6265	15.939 0.6275	IR-612-1	
0.013 0.028	0.015 0.033	15.875 0.6250	15.862 0.6245	20.650 0.8130	20.625 0.8120	20.650 0.8130	15.913 0.6265	15.939 0.6275	IR-612-1	
0.015 0.032	0.017 0.037	15.875 0.6250	15.862 0.6245	22.238 0.8755	22.212 0.8745	22.238 0.8755	15.913 0.6265	15.939 0.6275	IR-612-1	
0.024 0.052	0.028 0.062	15.875 0.6250	15.862 0.6245	22.238 0.8755	22.212 0.8745	22.238 0.8755	15.913 0.6265	15.939 0.6275		
0.014 0.030	0.016 0.036	17.463 0.6875	17.450 0.6870	22.238 0.8755	22.212 0.8745	22.238 0.8755	17.501 0.6890	17.526 0.6900	11/16	
0.016 0.035	0.019 0.042	17.463 0.6875	17.450 0.6870	23.825 0.9380	23.800 0.9370	23.825 0.9380	17.501 0.6890	17.526 0.6900		
0.019 0.042	—	17.463 0.6875	17.450 0.6870	23.825 0.9380	23.800 0.9370	23.825 0.9380	17.501 0.6890	17.526 0.6900		
0.010 0.022	—	19.050 0.7500	19.037 0.7495	25.413 1.0005	25.387 0.9995	25.387 0.9995	19.063 0.7505	19.088 0.7515	IR-88 3/4	
0.014 0.030	—	19.050 0.7500	19.037 0.7495	25.413 1.0005	25.387 0.9995	25.387 0.9995	19.063 0.7505	19.088 0.7515	IR-88	
0.017 0.038	0.020 0.045	19.050 0.7500	19.037 0.7495	25.413 1.0005	25.387 0.9995	25.387 0.9995	19.063 0.7505	19.088 0.7515	IR-812 ⁽¹⁾	
0.020 0.045	0.025 0.054	19.050 0.7500	19.037 0.7495	25.413 1.0005	25.387 0.9995	25.387 0.9995	19.063 0.7505	19.088 0.7515	IR-812 ⁽¹⁾	
0.026 0.058	0.031 0.069	19.050 0.7500	19.037 0.7495	27.000 1.0630	26.975 1.0620	26.975 1.0620	19.063 0.7505	19.088 0.7515	IR-812 ⁽¹⁾	
0.025 0.056	—	20.638 0.8125	20.625 0.8120	27.000 1.0630	26.975 1.0620	26.975 1.0620	20.650 0.8130	20.676 0.8140	13/16	
0.028 0.062	0.034 0.074	20.638 0.8125	20.625 0.8120	28.588 1.1255	28.562 1.1245	28.562 1.1245	20.650 0.8130	20.676 0.8140		
0.012 0.026	—	22.225 0.8750	22.212 0.8745	28.588 1.1255	28.562 1.1245	28.562 1.1245	22.238 0.8755	22.263 0.8765	IR-1012 ⁽¹⁾ 7/8	
0.015 0.034	—	22.225 0.8750	22.212 0.8745	28.588 1.1255	28.562 1.1245	28.562 1.1245	22.238 0.8755	22.263 0.8765	IR-1012 ⁽¹⁾	
0.024 0.052	0.028 0.062	22.225 0.8750	22.212 0.8745	28.588 1.1255	28.562 1.1245	28.562 1.1245	22.238 0.8755	22.263 0.8765	IR-1012 ⁽¹⁾	

⁽¹⁾ IRA inner ring provides additional length if required.

Continued on next page.



CAGED BEARINGS – OPEN ENDS, CLOSED ONE END – continued

INCH SERIES

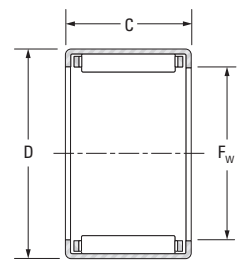

J, JH

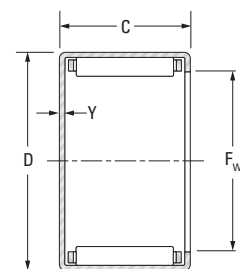

MJ-1, MJH-1

Full Complement Bearing

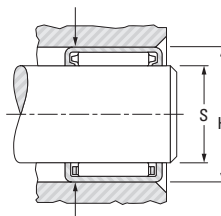

Caged Bearing

Shaft surface to be 58 HRC or equivalent

Drawn cup bearings of nominal inch dimensions, with one closed end, that are not tabulated, may be made available upon request.

Mounting dimensions are based on the inner ring rotating and the outer ring being stationary, relative to the load. The housing should be of high strength material.

See Engineering section for discussion of shaft and housing design.

Shaft Dia.	F _w	D	C		Y (max.)	Bearing Designation	Load Ratings		Speed Rating		C _g
			+0 +0.000	-0.3 -0.010			Dynamic	Static	Grease	Oil	
			mm in	mm in			C	C ₀			
in	mm in	mm in	mm in	mm in			kN lbf		min ⁻¹		
	22.225 0.8750	28.575 1.1250	25.40 1.000	1.02 0.040	J-1416	MJ-14161	23.66 5320	38.97 8760	9700	15000	0.0356
	22.225 0.8750	30.163 1.1875	19.05 0.750	1.27 0.050	JH-1412	MJH-14121	18.33 4120	24.55 5520	9800	15000	0.0309
	22.225 0.8750	30.163 1.1875	25.40 1.000	1.27 0.050	JH-1416	MJH-14161	25.40 5710	37.37 8400	9800	15000	0.0343
1	25.400 1.0000	31.750 1.2500	19.05 0.750	—	J-1612	—	18.15 4080	28.82 6480	8400	13000	0.0350
	25.400 1.0000	31.750 1.2500	25.40 1.000	1.02 0.040	J-1616	MJ-16161	24.95 5610	43.41 9760	8400	13000	0.0387
	25.400 1.0000	33.338 1.3125	19.05 0.750	1.27 0.050	JH-1612	MJH-16121	20.68 4650	29.58 6650	8500	13000	0.0342
	25.400 1.0000	33.338 1.3125	25.40 1.000	1.27 0.050	JH-1616	MJH-16161	27.58 6200	42.88 9640	8500	13000	0.0375
1 1/8	28.575 1.1250	34.925 1.3750	12.70 0.500	1.02 0.040	J-188	MJ-1881	11.65 2620	16.95 3810	7400	11000	0.0323
	28.575 1.1250	34.925 1.3750	19.05 0.750	1.02 0.040	J-1812	MJ-18121	19.04 4280	31.76 7140	7400	11000	0.0377
	28.575 1.1250	34.925 1.3750	25.40 1.000	1.02 0.040	J-1816	MJ-18161	26.16 5880	48.04 10800	7400	11000	0.0418
	28.575 1.1250	38.100 1.5000	19.05 0.750	1.27 0.050	JH-1812	MJH-18121	23.35 5250	31.32 7040	7600	12000	0.0356
	28.575 1.1250	38.100 1.5000	25.40 1.000	1.27 0.050	JH-1816	MJH-18161	33.14 7450	49.38 11100	7600	12000	0.0398
	28.575 1.1250	38.100 1.5000	28.58 1.125	1.27 0.050	JH-1818	MJH-18181	36.30 8160	55.16 12400	7600	12000	0.0410
1 1/4	31.750 1.2500	38.100 1.5000	19.05 0.750	1.02 0.040	J-2012	MJ-20121	19.84 4460	34.70 7800	6600	10000	0.0404
	31.750 1.2500	38.100 1.5000	25.40 1.000	1.02 0.040	J-2016	MJ-20161	28.82 6480	56.49 12700	6600	10000	0.0455
	31.750 1.2500	41.275 1.6250	19.05 0.750	—	JH-2012	—	24.11 5420	33.94 7630	6800	10000	0.0380
	31.750 1.2500	41.275 1.6250	25.40 1.000	—	JH-2016	—	33.94 7630	52.93 11900	6800	10000	0.0424
	31.750 1.2500	41.275 1.6250	31.75 1.250	—	JH-2020	—	43.37 9750	72.51 16300	6800	10000	0.0459
1 3/8	34.925 1.3750	41.275 1.6250	12.70 0.500	1.02 0.040	J-228	MJ-2281	13.97 3140	22.91 5150	6000	9200	0.0380
	34.925 1.3750	41.275 1.6250	19.05 0.750	—	J-2212	—	22.82 5130	42.97 9660	6000	9200	0.0444
	34.925 1.3750	44.450 1.7500	19.05 0.750	1.27 0.050	JH-2212	MJH-22121	26.24 5900	38.43 8640	6100	9400	0.0407
	34.925 1.3750	44.450 1.7500	25.40 1.000	1.27 0.050	JH-2216	MJH-22161	36.52 8210	58.72 13200	6100	9400	0.0452
1 1/2	38.100 1.5000	47.625 1.8750	19.05 0.750	1.27 0.050	J-2412	MJ-24121	29.89 6720	47.15 10600	5600	8600	0.0445

Approx. Wt.		S		H		Inspection		Mounting Inner Ring (pg B-120 to B-122)	Shaft Dia. in	
Open Ends	Closed End	Recommended Mounting Dimension				Ring Gage	Plug Gage			
		Max.	Min.	Max.	Min.		go			no go
kg lbs	kg lbs	mm in	mm in	mm in	mm in					
0.031 0.069	0.059 0.129	22.225 0.8750	22.212 0.8745	28.588 1.1255	28.562 1.1245	28.562 1.1245	22.238 0.8755	22.263 0.8765	IR-1016	
0.030 0.066	0.036 0.079	22.225 0.8750	22.212 0.8745	30.175 1.1880	30.150 1.1870	30.150 1.1870	22.238 0.8755	22.263 0.8765	IR-1012 ⁽¹⁾	
0.040 0.089	0.048 0.106	22.225 0.8750	22.212 0.8745	30.175 1.1880	30.150 1.1870	30.150 1.1870	22.238 0.8755	22.263 0.8765	IR-1016	
0.026 0.058	—	25.400 1.0000	25.387 0.9995	31.763 1.2505	31.737 1.2495	31.737 1.2495	25.413 1.0005	25.438 1.0015	IR-1212	
0.035 0.077	0.042 0.092	25.400 1.0000	25.387 0.9995	31.763 1.2505	31.737 1.2495	31.737 1.2495	25.413 1.0005	25.438 1.0015	IR-1216 ⁽¹⁾	
0.034 0.074	0.040 0.088	25.400 1.0000	25.387 0.9995	33.350 1.3130	33.325 1.3120	33.325 1.3120	25.413 1.0005	25.438 1.0015	IR-1212	
0.045 0.099	0.054 0.119	25.400 1.0000	25.387 0.9995	33.350 1.3130	33.325 1.3120	33.325 1.3120	25.413 1.0005	25.438 1.0015	IR-1216 ⁽¹⁾	
0.020 0.043	0.023 0.050	28.575 1.1250	28.562 1.1245	34.938 1.3755	34.912 1.3745	34.912 1.3745	28.588 1.1255	28.613 1.1265	IR-1416 ⁽¹⁾	
0.029 0.064	0.035 0.076	28.575 1.1250	28.562 1.1245	34.938 1.3755	34.912 1.3745	34.912 1.3745	28.588 1.1255	28.613 1.1265	IR-1416 ⁽¹⁾	
0.039 0.086	0.047 0.103	28.575 1.1250	28.562 1.1245	34.938 1.3755	34.912 1.3745	34.912 1.3745	28.588 1.1255	28.613 1.1265	IR-1416 ⁽¹⁾	
0.046 0.101	0.055 0.121	28.575 1.1250	28.562 1.1245	38.113 1.5005	38.087 1.4995	38.087 1.4995	28.588 1.1255	28.613 1.1265	IR-1416 ⁽¹⁾	
0.061 0.135	0.074 0.162	28.575 1.1250	28.562 1.1245	38.113 1.5005	38.087 1.4995	38.087 1.4995	28.588 1.1255	28.613 1.1265	IR-1416 ⁽¹⁾	
0.069 0.152	0.082 0.181	28.575 1.1250	28.562 1.1245	38.113 1.5005	38.087 1.4995	38.087 1.4995	28.588 1.1255	28.613 1.1265		
0.036 0.080	0.043 0.095	31.750 1.2500	31.737 1.2495	38.113 1.5005	38.087 1.4995	38.087 1.4995	31.763 1.2505	31.788 1.2515	IR-1612	
0.043 0.094	0.051 0.113	31.750 1.2500	31.737 1.2495	38.113 1.5005	38.087 1.4995	38.087 1.4995	31.763 1.2505	31.788 1.2515	IR-1616 ⁽¹⁾	
0.050 0.111	—	31.750 1.2500	31.737 1.2495	41.288 1.6255	41.262 1.6245	41.262 1.6245	31.763 1.2505	31.788 1.2515	IR-1612	
0.067 0.148	—	31.750 1.2500	31.737 1.2495	41.288 1.6255	41.262 1.6245	41.262 1.6245	31.763 1.2505	31.788 1.2515	IR-1616 ⁽¹⁾	
0.084 0.185	—	31.750 1.2500	31.737 1.2495	41.288 1.6255	41.262 1.6245	41.262 1.6245	31.763 1.2505	31.788 1.2515		
0.024 0.052	0.028 0.062	34.925 1.3750	34.912 1.3745	41.288 1.6255	41.262 1.6245	41.262 1.6245	34.938 1.3755	34.966 1.3766	IR-1812	
0.035 0.077	—	34.925 1.3750	34.912 1.3745	41.288 1.6255	41.262 1.6245	41.262 1.6245	34.938 1.3755	34.966 1.3766	IR-1812	
0.055 0.121	0.065 0.144	34.925 1.3750	34.912 1.3745	44.463 1.7505	44.437 1.7495	44.437 1.7495	34.938 1.3755	34.966 1.3766	IR-1812	
0.073 0.161	0.087 0.192	34.925 1.3750	34.912 1.3745	44.463 1.7505	44.437 1.7495	44.437 1.7495	34.938 1.3755	34.966 1.3766	IR-1816	
0.059 0.131	0.094 0.208	38.100 1.5000	38.087 1.4995	47.638 1.8755	47.612 1.8745	47.612 1.8745	38.113 1.5005	38.143 1.5017	IR-1916	

⁽¹⁾ IRA inner ring provides additional length if required.

Continued on next page.



**CAGED BEARINGS –
OPEN ENDS, CLOSED ONE END – continued**

INCH SERIES

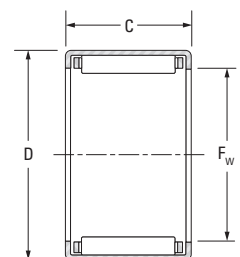

J, JH

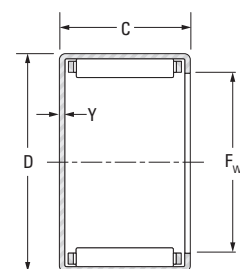

MJ-1, MJH-1

Full Complement Bearing

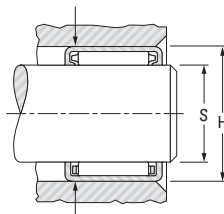

Caged Bearing

Shaft surface to be 58 HRC or equivalent

Drawn cup bearings of nominal inch dimensions, with one closed end, that are not tabulated, may be made available upon request.

Mounting dimensions are based on the inner ring rotating and the outer ring being stationary, relative to the load. The housing should be of high strength material.

See Engineering section for discussion of shaft and housing design.

Shaft Dia.	F _w	D	C		Y (max.)	Bearing Designation	Load Ratings		Speed Rating		C _g
			+0 +0.000	-0.3 -0.010			Dynamic	Static	Grease	Oil	
			mm in	mm in			C	C ₀			
in	mm in	mm in	mm in	mm in			kN lbf		min ⁻¹		
	38.100 1.5000	47.625 1.8750	25.40 1.000	1.27 0.050	J-2416	MJ-24161	39.32 8840	66.72 15000	5600	8600	0.0486
	38.100 1.5000	47.625 1.8750	31.75 1.250	—	J-2420	—	49.38 11100	89.85 20200	5600	8600	0.0523
1 5/8	41.275 1.6250	50.800 2.0000	15.88 0.625	—	J-2610	—	26.11 5870	40.97 9210	5100	7900	0.0446
	41.275 1.6250	50.800 2.0000	25.40 1.000	1.27 0.050	J-2616	M-26161	39.28 8830	68.95 15500	5100	7900	0.0508
1 3/4	44.450 1.7500	53.975 2.1250	19.05 0.750	1.27 0.050	J-2812	MJ-28121	29.58 6650	49.38 11100	4700	7300	0.0483
	44.450 1.7500	53.975 2.1250	25.40 1.000	1.27 0.050	J-2816	MJ-28161	40.08 9010	72.95 16400	4700	7300	0.0532
	44.450 1.7500	53.975 2.1250	38.10 1.500	1.27 0.050	J-2824	MJ-28241	59.61 13400	121.88 27400	4700	7300	0.0605
1 7/8	47.625 1.8750	57.150 2.2500	25.40 1.000	1.27 0.050	J-3016	MJ-30161	41.10 9240	76.06 17100	4400	6800	0.0553
2	50.800 2.0000	60.325 2.3750	25.40 1.000	1.27 0.050	J-3216	MJ-32161	42.39 9530	81.40 18300	4100	6300	0.0579
2 1/4	57.150 2.2500	66.675 2.6250	19.05 0.750	—	J-3612	—	35.41 7960	65.83 14800	3600	5600	0.0577
	57.150 2.2500	66.675 2.6250	25.40 1.000	—	J-3616	—	46.26 10400	92.52 20800	3600	5600	0.0628
2 3/4	69.850 2.7500	79.375 3.1250	19.05 0.750	—	J-4412	—	36.25 8150	72.95 16400	2900	4500	0.0649

Approx. Wt.		S		H		Inspection		Mounting Inner Ring (pg B-120 to B-122)	Shaft Dia. in	
Open Ends	Closed End	Recommended Mounting Dimension				Ring Gage	Plug Gage			
		Max.	Min.	Max.	Min.		go			no go
kg lbs	kg lbs	mm in	mm in	mm in	mm in					
0.079 0.174	0.094 0.208	38.100 1.5000	38.087 1.4995	47.638 1.8755	47.612 1.8745	47.612 1.8745	38.113 1.5005	38.143 1.5017	IR-1916	
0.099 0.218	—	38.100 1.5000	38.087 1.4995	47.638 1.8755	47.612 1.8745	47.612 1.8745	38.113 1.5005	38.143 1.5017	IR-1920	
0.053 0.117	—	41.275 1.6250	41.262 1.6245	50.813 2.0005	50.787 1.9995	50.787 1.9995	41.288 1.6255	41.318 1.6267	IR-2020 ⁽¹⁾	
0.085 0.187	0.101 0.223	41.275 1.6250	41.262 1.6245	50.813 2.0005	50.787 1.9995	50.787 1.9995	41.288 1.6255	41.318 1.6267	IR-2020 ⁽¹⁾	
0.068 0.150	0.081 0.179	44.450 1.7500	44.437 1.7495	53.988 2.1255	53.962 2.1245	53.962 2.1245	44.463 1.7505	44.496 1.7518	IR-2316	
0.091 0.200	0.108 0.239	44.450 1.7500	44.437 1.7495	53.988 2.1255	53.962 2.1245	53.962 2.1245	44.463 1.7505	44.496 1.7518	IR-2316	
0.136 0.300	0.162 0.358	44.450 1.7500	44.437 1.7495	53.988 2.1255	53.962 2.1245	53.962 2.1245	44.463 1.7505	44.496 1.7518	IR-2324	
0.097 0.213	0.115 0.254	47.625 1.8750	47.612 1.8745	57.163 2.2505	57.137 2.2495	57.137 2.2495	47.638 1.8755	47.671 1.8768	1 7/8	
0.103 0.226	0.137 0.301	50.800 2.0000	50.785 1.9994	60.338 2.3755	60.312 2.3745	60.312 2.3745	50.815 2.0006	50.848 2.0019	2	
0.086 0.189	—	57.150 2.2500	57.135 2.2494	66.688 2.6255	66.662 2.6245	66.662 2.6245	57.165 2.2506	57.203 2.2521	2 1/4	
0.114 0.252	—	57.150 2.2500	57.135 2.2494	66.688 2.6255	66.662 2.6245	66.662 2.6245	57.165 2.2506	57.203 2.2521		
0.103 0.227	—	69.850 2.7500	69.835 2.7494	79.388 3.1255	79.362 3.1245	79.362 3.1245	69.875 2.7510	69.914 2.7525	IR-4016	

⁽¹⁾ IRA inner ring provides additional length if required.



SEALED DRAWN CUP BEARINGS

INCH SERIES

- Check for availability. Not all bearings are in production.
- Pre-packed with general purpose ball and roller bearing grease unless otherwise specified.
- Bearing operating temperature limited between -30° C and +110° C (-25° F and +225° F).
- Consult your representative for operating temperatures outside the above range or if seals have been exposed to unusual fluids.
- Speed rating based on shaft contact speed of 610 m/min. (2000 fpm).
- Reduce the listed speed rating by one-half for outer ring rotation.

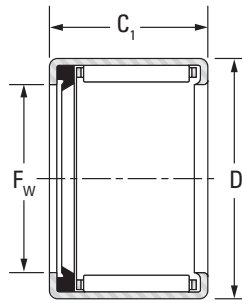

JT – One Seal

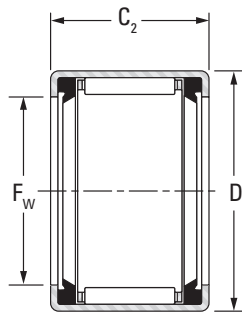

JTT – Two Seals

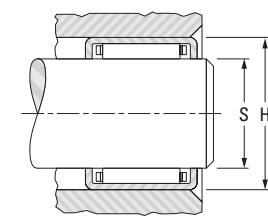

Shaft surface to be 58 HRC or equivalent

Drawn cup bearings of nominal inch dimensions, with one closed end, that are not tabulated, may be made available upon request.

Mounting dimensions are based on the inner ring rotating and the outer ring being stationary, relative to the load. The housing should be of high strength material.

Shaft Dia.	F _w	D	Bearings With One Seal			Bearings With Two Seals		
			C ₁ +0 +0.000 -0.3 -0.010	Bearing Designation	Approx. Wt.	C ₂ +0 +0.000 -0.3 -0.010	Bearing Designation	Approx. Wt.
in	mm in	mm in	mm in		kg lbs	mm in		kg lbs
5/16	7.938 0.3125	12.700 0.5000	9.53 0.375	JT-56	0.004 0.008	11.13 0.438	JTT-57	0.004 0.009
	7.938 0.3125	12.700 0.5000	—	—	—	14.27 0.562	JTT-59	0.005 0.012
3/8	9.525 0.3750	14.288 0.5625	9.53 0.375	JT-66	0.004 0.009	11.13 0.438	JTT-67	0.005 0.011
	9.525 0.3750	14.288 0.5625	14.27 0.562	JT-69	0.006 0.014	—	—	—
1/2	12.700 0.5000	17.463 0.6875	9.53 0.375	JT-86	0.005 0.012	11.13 0.438	JTT-87	0.006 0.013
	12.700 0.5000	17.463 0.6875	14.27 0.562	JT-89	0.008 0.017	15.88 0.625	JTT-810	0.009 0.019
9/16	12.700 0.5000	17.463 0.6875	—	—	—	22.23 0.875	JTT-814	0.012 0.027
	14.288 0.5625	19.050 0.7500	14.27 0.562	JT-99	0.009 0.019	15.88 0.625	JTT-910	0.010 0.021
5/8	14.288 0.5625	19.050 0.7500	—	—	—	19.05 0.750	JTT-912	0.011 0.025
	15.875 0.6250	20.638 0.8125	14.27 0.562	JT-109	0.010 0.021	15.88 0.625	JTT-1010	0.010 0.023
11/16	15.875 0.6250	20.638 0.8125	—	—	—	19.05 0.750	JTT-1012	0.013 0.028
	15.875 0.6250	20.638 0.8125	—	—	—	22.23 0.875	JTT-1014	0.015 0.032
3/4	17.463 0.6875	22.225 0.8750	—	—	—	22.23 0.875	JTT-1114	0.016 0.035
	19.050 0.7500	25.400 1.0000	14.27 0.562	JT-129	0.015 0.034	15.88 0.625	JTT-1210	0.017 0.038
7/8	19.050 0.7500	25.400 1.0000	17.48 0.688	JT-1211	0.019 0.041	—	—	—
	19.050 0.7500	25.400 1.0000	20.62 0.812	JT-1213	0.022 0.049	22.23 0.875	JTT-1214	0.024 0.053
1	22.225 0.8750	28.575 1.1250	14.27 0.562	JT-149	0.018 0.039	15.88 0.625	JTT-1410	0.020 0.043
	22.225 0.8750	28.575 1.1250	26.97 1.062	JT-1417	0.033 0.073	—	—	—
1 1/8	25.400 1.0000	31.750 1.2500	20.62 0.812	JT-1613	0.029 0.063	22.23 0.875	JTT-1614	0.031 0.068
1 1/4	28.575 1.1250	34.925 1.3750	20.62 0.812	JT-1813	0.032 0.070	22.23 0.875	JTT-1814	0.034 0.075
1 1/2	31.750 1.2500	38.100 1.5000	20.62 0.812	JT-2013	0.035 0.077	—	—	—
1 5/8	31.750 1.2500	38.100 1.5000	—	—	—	28.58 1.125	JTT-2018	0.048 0.106
1 3/4	38.100 1.5000	47.625 1.8750	33.32 1.312	JT-2421	0.104 0.229	—	—	—

Load Ratings		Approx. Speed Rating (Grease)	C ₀	S				H				Inspection		Shaft Dia. in
Dynamic	Static			Mounting Dimension				Ring Gage	Plug Gage					
C	C ₀			Max.	Min.	Max.	Min.	go	no go					
kN lbf	min ⁻¹	mm in	mm in	mm in	mm in									
2.40 540	2.00 450	18000	0.0117	7.938 0.3125	7.925 0.3120	12.713 0.5005	12.687 0.4995	12.713 0.5005	7.976 0.3140	8.001 0.3150	5/16			
4.05 910	3.91 880	18000	0.0138	7.938 0.3125	7.925 0.3120	12.713 0.5005	12.687 0.4995	12.713 0.5005	7.976 0.3140	8.001 0.3150				
2.74 615	2.49 560	18000	0.0133	9.525 0.3750	9.512 0.3745	14.300 0.5630	14.275 0.5620	14.300 0.5630	9.563 0.3765	9.589 0.3775	3/8			
5.20 1170	5.74 1290	18000	0.0163	9.525 0.3750	9.512 0.3745	14.300 0.5630	14.275 0.5620	14.300 0.5630	9.563 0.3765	9.589 0.3775				
3.47 780	3.65 820	15000	0.0164	12.700 0.5000	12.687 0.4995	17.475 0.6880	17.450 0.6870	17.475 0.6880	12.738 0.5015	12.764 0.5025	1/2			
6.32 1420	7.92 1780	15000	0.0199	12.700 0.5000	12.687 0.4995	17.475 0.6880	17.450 0.6870	17.475 0.6880	12.738 0.5015	12.764 0.5025				
10.2 2300	14.7 3310	15000	0.0232	12.700 0.5000	12.687 0.4995	17.475 0.6880	17.450 0.6870	17.475 0.6880	12.738 0.5015	12.764 0.5025				
6.23 1400	8.01 1800	14000	0.0210	14.288 0.5625	14.275 0.5620	19.063 0.7505	19.037 0.7495	19.063 0.7505	14.326 0.5640	14.351 0.5650	9/16			
8.18 1840	11.4 2560	14000	0.0229	14.288 0.5625	14.275 0.5620	19.063 0.7505	19.037 0.7495	19.063 0.7505	14.326 0.5640	14.351 0.5650				
6.72 1510	9.12 2050	12000	0.0227	15.875 0.6250	15.862 0.6245	20.650 0.8130	20.625 0.8120	20.650 0.8130	15.913 0.6265	15.939 0.6275	5/8			
8.81 1980	12.9 2910	12000	0.0247	15.875 0.6250	15.862 0.6245	20.650 0.8130	20.625 0.8120	20.650 0.8130	15.913 0.6265	15.939 0.6275				
11.7 2640	18.9 4240	12000	0.0272	15.875 0.6250	15.862 0.6245	20.650 0.8130	20.625 0.8120	20.650 0.8130	15.913 0.6265	15.939 0.6275				
12.5 2800	20.9 4700	11000	0.0290	17.463 0.6875	17.450 0.6870	22.238 0.8755	22.212 0.8745	22.238 0.8755	17.501 0.6890	17.526 0.6900	11/16			
9.92 2230	12.2 2740	10000	0.0250	19.050 0.7500	19.037 0.7495	25.413 1.0005	25.387 0.9995	25.387 0.9995	19.063 0.7505	19.088 0.7515	3/4			
12.5 2810	16.3 3670	10000	0.0269	19.050 0.7500	19.037 0.7495	25.413 1.0005	25.387 0.9995	25.387 0.9995	19.063 0.7505	19.088 0.7515				
15.5 3490	21.6 4860	10000	0.0288	19.050 0.7500	19.037 0.7495	25.413 1.0005	25.387 0.9995	25.387 0.9995	19.063 0.7505	19.088 0.7515				
10.9 2460	14.5 3260	8700	0.0278	22.225 0.8750	22.212 0.8745	28.588 1.1255	28.562 1.1245	28.562 1.1245	22.238 0.8755	22.263 0.8765	7/8			
23.7 5320	39.0 8760	8700	0.0356	22.225 0.8750	22.212 0.8745	28.588 1.1255	28.562 1.1245	28.562 1.1245	22.238 0.8755	22.263 0.8765				
18.1 4080	28.8 6480	7600	0.035	25.400 1.0000	25.387 0.9995	31.763 1.2505	31.737 1.2495	31.737 1.2495	25.413 1.0005	25.438 1.0015	1			
19.0 4280	31.8 7140	6800	0.0377	28.575 1.1250	28.562 1.1245	34.938 1.3755	34.912 1.3745	34.912 1.3745	28.588 1.1255	28.613 1.1265	1 1/8			
19.8 4460	34.7 7800	6100	0.0404	31.750 1.2500	31.737 1.2495	38.113 1.5005	38.087 1.4995	38.087 1.4995	31.763 1.2505	31.788 1.2515	1 1/4			
28.8 6480	56.5 12700	6100	0.0455	31.750 1.2500	31.737 1.2495	38.113 1.5005	38.087 1.4995	38.087 1.4995	31.763 1.2505	31.788 1.2515				
49.4 11100	89.9 20200	5100	0.0523	38.100 1.5000	38.087 1.4995	47.638 1.8755	47.612 1.8745	47.612 1.8745	38.113 1.5005	38.143 1.5017	1 1/2			



INNER RINGS FOR INCH SERIES DRAWN CUP BEARINGS

- Check for availability.
- Ideal choice when shaft is not practical to use as inner raceway.
- Provided in inch (IR, IRA) nominal dimensions for use with inch series drawn cup bearings.
- Designed to meet established inch tolerances.
- Designed to be wider than matching drawn cup bearing.
- Maximum shaft fillet radius ($r_{a\max}$) cannot exceed inner ring bore chamfer ($r_{s\min}$) as shown.
- Optional centralized lubrication groove (bore) and thru-hole available – specify when ordering.
- Designed to provide a loose transition fit on the shaft and should be axially clamped against a shoulder.

- If a tight transition fit must be used to keep the inner ring from rotating relative to the shaft, the inner ring O.D. must not exceed the raceway diameter for the matching drawn cup bearing after being mounted on the shaft.
- See tables for bearing raceway diameter dimensions.
- After mounting, if O.D. of inner ring exceeds required raceway diameter for matching bearing, ring should be ground to proper diameter while mounted on shaft.

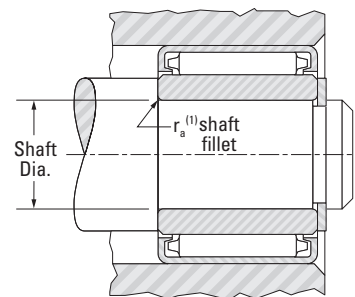
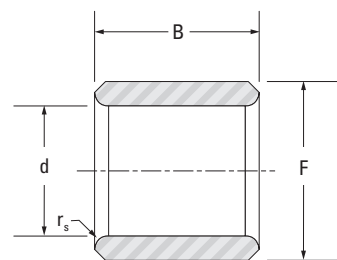

Shaft Dia.	d		F		B		$r_{s\min}$	Inner Ring Designation	Mounting Dimensions Transition Fit				Approx. Wt.
	Max.	Min.	Max.	Min.	Max.	Min.			Loose		Tight		
									Max.	Min.	Max.	Min.	
in	mm in	mm in	mm in	mm in	mm in	mm in	mm in	mm in	mm in	mm in	mm in	kg lbs	
3/16	4.826	4.813	9.525	9.512	13.61	13.36	0.64	IRA-3	4.818	4.806	4.829	4.816	0.005
	0.1900	0.1895	0.3750	0.3745	0.536	0.526	0.025		0.1897	0.1892	0.1901	0.1896	
1/4	6.350	6.337	11.113	11.100	13.61	13.36	0.64	IRA-4	6.342	6.330	6.353	6.340	0.006
	0.2500	0.2495	0.4375	0.4370	0.536	0.526	0.025		0.2497	0.2492	0.2501	0.2496	
5/16	7.938	7.925	12.700	12.687	13.61	13.36	0.64	IRA-5	7.930	7.917	7.940	7.927	0.008
	0.3125	0.3120	0.5000	0.4995	0.536	0.526	0.025		0.3122	0.3117	0.3126	0.3121	
3/8	9.525	9.512	14.288	14.275	13.08	12.83	0.64	IR-68	9.517	9.505	9.528	9.515	0.009
	0.3750	0.3745	0.5625	0.5620	0.515	0.505	0.025		0.3747	0.3742	0.3751	0.3746	
	9.525	9.512	14.288	14.275	19.43	19.18	0.64	IR-612	9.517	9.505	9.528	9.515	0.013
	0.3750	0.3745	0.5625	0.5620	0.765	0.755	0.025		0.3747	0.3742	0.3751	0.3746	
	9.525	9.512	14.288	14.275	19.96	19.71	0.64	IRA-6	9.517	9.505	9.528	9.515	0.013
	0.3750	0.3745	0.5625	0.5620	0.786	0.776	0.025		0.3747	0.3742	0.3751	0.3746	
	9.525	9.512	15.875	15.862	13.08	12.83	0.64	IR-68-1	9.517	9.505	9.528	9.515	0.012
	0.3750	0.3745	0.6250	0.6245	0.515	0.505	0.025		0.3747	0.3742	0.3751	0.3746	
	9.525	9.512	15.875	15.862	19.43	19.18	0.64	IR-612-1	9.517	9.505	9.528	9.515	0.018
	0.3750	0.3745	0.6250	0.6245	0.765	0.755	0.025		0.3747	0.3742	0.3751	0.3746	
7/16	11.113	11.100	15.875	15.862	19.96	19.71	0.64	IRA-7	11.105	11.092	11.115	11.102	0.015
	0.4375	0.4370	0.6250	0.6245	0.786	0.776	0.025		0.4372	0.4367	0.4376	0.4371	
1/2	12.700	12.687	19.050	19.037	13.08	12.83	1.02	IR-88	12.692	12.680	12.703	12.690	0.015
	0.5000	0.4995	0.7500	0.7495	0.515	0.505	0.040		0.4997	0.4992	0.5001	0.4996	
	12.700	12.687	19.050	19.037	19.43	19.18	1.02	IR-812	12.692	12.680	12.703	12.690	0.023
	0.5000	0.4995	0.7500	0.7495	0.765	0.755	0.040		0.4997	0.4992	0.5001	0.4996	

Bore and O.D. tolerance limits correspond to the single mean diameter (the arithmetical mean of the largest and smallest diameters in a single radial plane).

⁽¹⁾ $r_{a\max}$ is equal to minimum inner ring bore chamfer ($r_{s\min}$).

Shaft Dia.	d		F		B		$r_{s\min}$	Inner Ring Designation	Mounting Dimensions Transition Fit				Approx. Wt.
	Max.	Min.	Max.	Min.	Max.	Min.			Loose		Tight		
									Max.	Min.	Max.	Min.	
in	mm in	mm in	mm in	mm in	mm in	mm in	mm in	mm in	mm in	mm in	mm in	kg lbs	
1/2	12.700	12.687	19.050	19.037	19.96	19.71	1.02	IRA-8	12.692	12.680	12.703	12.690	0.023
	0.5000	0.4995	0.7500	0.7495	0.786	0.776	0.040		0.4997	0.4992	0.5001	0.4996	
5/8	15.875	15.862	22.225	22.212	19.43	19.18	1.02	IR-1012	15.867	15.855	15.878	15.865	0.027
	0.6250	0.6245	0.8750	0.8745	0.765	0.755	0.040		0.6247	0.6242	0.6251	0.6246	
	15.875	15.862	22.225	22.212	19.96	19.71	1.02	IRA-10	15.867	15.855	15.878	15.865	0.028
	0.6250	0.6245	0.8750	0.8745	0.786	0.776	0.040		0.6247	0.6242	0.6251	0.6246	
	15.875	15.862	22.225	22.212	25.78	25.53	1.02	IR-1016	15.867	15.855	15.878	15.865	0.036
	0.6250	0.6245	0.8750	0.8745	1.015	1.005	0.040		0.6247	0.6242	0.6251	0.6246	
3/4	19.050	19.037	25.400	25.387	13.08	12.83	1.02	IR-128	19.042	19.030	19.053	19.040	0.021
	0.7500	0.7495	1.0000	0.9995	0.515	0.505	0.040		0.7497	0.7492	0.7501	0.7496	
	19.050	19.037	25.400	25.387	19.43	19.18	1.02	IR-1212	19.042	19.030	19.053	19.040	0.032
	0.7500	0.7495	1.0000	0.9995	0.765	0.755	0.040		0.7497	0.7492	0.7501	0.7496	
	19.050	19.037	25.400	25.387	25.78	25.53	1.02	IR-1216	19.042	19.030	19.053	19.040	0.042
	0.7500	0.7495	1.0000	0.9995	1.015	1.005	0.040		0.7497	0.7492	0.7501	0.7496	
	19.050	19.037	25.400	25.387	26.31	26.06	1.02	IRA-12	19.042	19.030	19.053	19.040	0.043
	0.7500	0.7495	1.0000	0.9995	1.036	1.026	0.040		0.7497	0.7492	0.7501	0.7496	
	19.050	19.037	25.400	25.387	32.13	31.88	1.02	IR-1220	19.042	19.030	19.053	19.040	0.053
	0.7500	0.7495	1.0000	0.9995	1.265	1.255	0.040		0.7497	0.7492	0.7501	0.7496	
	19.050	19.037	25.400	25.387	38.48	38.23	1.02	IR-1224	19.042	19.030	19.053	19.040	0.063
	0.7500	0.7495	1.0000	0.9995	1.515	1.505	0.040		0.7497	0.7492	0.7501	0.7496	
13/16	20.638	20.625	25.400	25.387	19.43	19.18	1.02	IR-1312	20.630	20.617	20.640	20.627	0.024
	0.8125	0.8120	1.0000	0.9995	0.765	0.755	0.040		0.8122	0.8117	0.8126	0.8121	
	20.638	20.625	25.400	25.387	25.78	25.53	1.02	IR-1316	20.630	20.617	20.640	20.627	0.033
	0.8125	0.8120	1.0000	0.9995	1.015	1.005	0.040		0.8122	0.8117	0.8126	0.8121	
7/8	22.225	22.212	28.575	28.562	25.78	25.53	1.02	IR-1416	22.217	22.205	22.228	22.215	0.050
	0.8750	0.8745	1.1250	1.1245	1.015	1.005	0.040		0.8747	0.8742	0.8751	0.8746	
	22.225	22.212	28.575	28.562	26.31	26.06	1.02	IRA-14	22.217	22.205	22.228	22.215	0.050
	0.8750	0.8745	1.1250	1.1245	1.036	1.026	0.040		0.8747	0.8742	0.8751	0.8746	
15/16	23.813	23.800	28.575	28.562	25.78	25.53	1.02	IR-1516	23.805	23.792	23.815	23.802	0.037
	0.9375	0.9370	1.1250	1.1245	1.015	1.005	0.040		0.9372	0.9367	0.9376	0.9371	
1	25.400	25.387	31.750	31.737	19.43	19.18	1.02	IR-1612	25.392	25.380	25.403	25.390	0.041
	1.0000	0.9995	1.2500	1.2495	0.765	0.755	0.040		0.9997	0.9992	1.0001	0.9996	
	25.400	25.387	31.750	31.737	25.78	25.53	1.02	IR-1616	25.392	25.380	25.403	25.390	0.057
	1.0000	0.9995	1.2500	1.2495	1.015	1.005	0.040		0.9997	0.9992	1.0001	0.9996	
	25.400	25.387	31.750	31.737	26.31	26.06	1.02	IRA-16	25.392	25.380	25.403	25.390	0.056
	1.0000	0.9995	1.2500	1.2495	1.036	1.026	0.040		0.9997	0.9992	1.0001	0.9996	
1 1/8	28.575	28.562	34.925	34.912	19.43	19.18	1.02	IR-1812	28.567	28.555	28.578	28.565	0.045
	1.1250	1.1245	1.3750	1.3745	0.765	0.755	0.040		1.1247	1.1242	1.1251	1.1246	
	28.575	28.562	34.925	34.912	25.78	25.53	1.02	IR-1816	28.567	28.555	28.578	28.565	0.060
	1.1250	1.1245	1.3750	1.3745	1.015	1.005	0.040		1.1247	1.1242	1.1251	1.1246	
	28.575	28.562	34.925	34.912	32.13	31.88	1.02	IR-1820	28.567	28.555	28.578	28.565	0.075
	1.1250	1.1245	1.3750	1.3745	1.265	1.255	0.040		1.1247	1.1242	1.1251	1.1246	
1 3/16	30.163	30.150	38.100	38.087	25.78	25.53	1.02	IR-1916	30.155	30.142	30.165	30.152	0.084
	1.1875	1.1870	1.5000	1.4995	1.015	1.005	0.040		1.1872	1.1867	1.1876	1.1871	
	30.163	30.150	38.100	38.087	32.13	31.88	1.02	IR-1920	30.155	30.142	30.165	30.152	0.101
	1.1875	1.1870	1.5000	1.4995									



INNER RINGS FOR INCH SERIES

DRAWN CUP BEARINGS—continued

- Check for availability.
- Ideal choice when shaft is not practical to use as inner raceway.
- Provided in inch (IR, IRA) nominal dimensions for use with inch series drawn cup bearings.
- Designed to meet established inch tolerances.
- Designed to be wider than matching drawn cup bearing.
- Maximum shaft fillet radius ($r_{a \max}$) cannot exceed inner ring bore chamfer ($r_{s \min}$) as shown.
- Optional centralized lubrication groove (bore) and thru-hole available – specify when ordering.
- Designed to provide a loose transition fit on the shaft and should be axially clamped against a shoulder.

- If a tight transition fit must be used to keep the inner ring from rotating relative to the shaft, the inner ring O.D. must not exceed the raceway diameter for the matching drawn cup bearing after being mounted on the shaft.
- See tables for bearing raceway diameter dimensions.
- After mounting, if O.D. of inner ring exceeds required raceway diameter for matching bearing, ring should be ground to proper diameter while mounted on shaft.

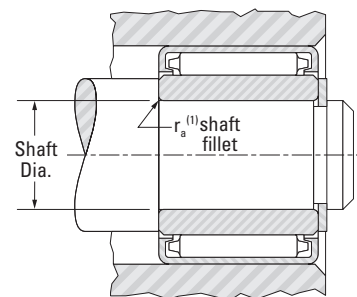
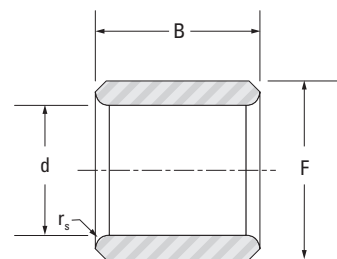

Shaft Dia.	d		F		B		$r_{s \min}$	Inner Ring Designation	Mounting Dimensions Transition Fit				Approx. Wt.
	Max.	Min.	Max.	Min.	Max.	Min.			Loose		Tight		
									Max.	Min.	Max.	Min.	
in	mm in	mm in	mm in	mm in	mm in	mm in	mm in	mm in	mm in	mm in	mm in	kg lbs	
1 1/4	31.750 1.2500	31.737 1.2495	38.100 1.5000	38.087 1.4995	32.66 1.286	32.41 1.276	1.52 0.060	IRA-20	31.742 1.2497	31.730 1.2492	31.753 1.2501	31.740 1.2496	0.086 0.190
1 3/8	34.925 1.3750	34.912 1.3745	41.275 1.6250	41.262 1.6245	32.13 1.265	31.88 1.255	1.52 0.060	IR-2220	34.917 1.3747	34.905 1.3742	34.928 1.3751	34.915 1.3746	0.094 0.208
1 7/16	36.513 1.4375	36.500 1.4370	44.450 1.7500	44.437 1.7495	25.78 1.015	25.53 1.005	1.52 0.060	IR-2316	36.505 1.4372	36.492 1.4367	36.515 1.4376	36.502 1.4371	0.100 0.220
	36.513 1.4375	36.500 1.4370	44.450 1.7500	44.437 1.7495	38.48 1.515	38.23 1.505	1.52 0.060	IR-2324	36.505 1.4372	36.492 1.4367	36.515 1.4376	36.502 1.4371	0.150 0.331
1 1/2	38.100 1.5000	38.087 1.4995	44.450 1.7500	44.437 1.7495	25.78 1.015	25.53 1.005	1.52 0.060	IR-2416	38.092 1.4997	38.080 1.4992	38.103 1.5001	38.090 1.4996	0.078 0.173
	38.100 1.5000	38.087 1.4995	44.450 1.7500	44.437 1.7495	38.48 1.515	38.23 1.505	1.52 0.060	IR-2424	38.092 1.4997	38.080 1.4992	38.103 1.5001	38.090 1.4996	0.122 0.270
1 11/16	42.863 1.6875	42.850 1.6870	52.388 2.0625	52.375 2.0620	38.48 1.515	38.23 1.505	1.52 0.060	IR-2724	42.855 1.6872	42.842 1.6867	42.865 1.6876	42.852 1.6871	0.212 0.468
1 3/4	44.450 1.7500	44.437 1.7495	52.388 2.0625	52.375 2.0620	38.48 1.515	38.23 1.505	1.52 0.060	IR-2824	44.442 1.7497	44.430 1.7492	44.453 1.7501	44.440 1.7496	0.180 0.396
1 13/16	46.038 1.8125	46.025 1.8120	52.388 2.0625	52.375 2.0620	25.78 1.015	25.53 1.005	1.52 0.060	IR-2916	46.030 1.8122	46.017 1.8117	46.040 1.8126	46.027 1.8121	0.097 0.214
	46.038 1.8125	46.025 1.8120	52.388 2.0625	52.375 2.0620	38.48 1.515	38.23 1.505	1.52 0.060	IR-2924	46.030 1.8122	46.017 1.8117	46.040 1.8126	46.027 1.8121	0.146 0.322
1 7/8	47.625 1.8750	47.612 1.8745	53.975 2.1250	53.962 2.1245	38.48 1.515	38.23 1.505	1.52 0.060	IR-3024	47.617 1.8747	47.605 1.8742	47.628 1.8751	47.615 1.8746	0.145 0.319
2 1/2	63.500 2.5000	63.487 2.4995	69.850 2.7500	69.837 2.7495	25.78 1.015	25.53 1.005	1.52 0.060	IR-4016	63.495 2.4998	63.477 2.4991	63.505 2.5002	63.487 2.4995	0.132 0.290

Bore and O.D. tolerance limits correspond to the single mean diameter (the arithmetical mean of the largest and smallest diameters in a single radial plane).

⁽¹⁾ $r_a \max$ is equal to minimum inner ring bore chamfer ($r_s \min$).

DRAWN CUP ROLLER CLUTCHES

Overview: Drawn cup needle roller clutches are similar to drawn cup needle roller bearings in design; however, they allow free rotation in only one direction while transmitting torque in the opposite direction. These designs use the same small radial section as drawn cup needle roller bearings and are offered as clutch-only units or as clutch and bearing assemblies.

- **Sizes:** 3.2 mm – 35 mm (0.1250 in – 1.3780 in) bore.
- **Markets:** Office equipment, paper-towel dispensers, exercise equipment, appliances and two-speed gearboxes.
- **Features:** Compact, lightweight and operate directly on a hardened shaft.
- **Benefits:** Installation is easily accomplished with a simple press fit.





Drawn Cup Roller Clutches

Metric Series	
FCS, FC-K	regular clutch, single roller per stainless steel spring
FC	regular clutch, multi-roller per stainless steel spring
FCL-K	light series clutch, single roller per stainless steel spring
FCB	regular clutch and bearing assembly, multi-roller per stainless steel spring
FCBL-K, FCBN-K	light series clutch and bearing assembly, single roller per stainless steel spring

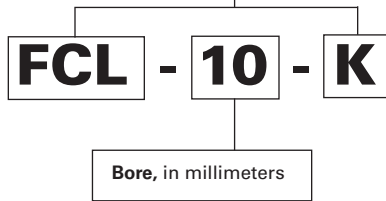

Inch Series	
RC	regular clutch, single roller per integral spring
RC-FS	regular clutch, single roller per stainless steel spring
RCB	regular clutch and bearing assembly, single roller per integral spring
RCB-FS	regular clutch and bearing assembly, single roller per stainless steel spring

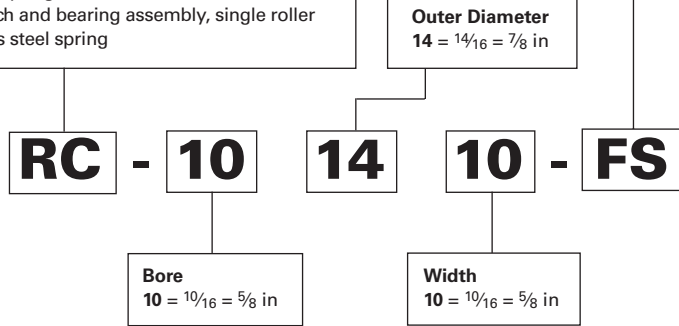

Drawn Cup Roller Clutches

	<i>Page</i>
Introduction	B-126
Drawn Cup Roller Clutches – Metric Series	B-132
Drawn Cup Roller Clutches and Bearing Assemblies – Metric Series	B-134
Drawn Cup Roller Clutches – Inch Series	B-136
Drawn Cup Roller Clutch and Bearing Assemblies – Inch Series	B-138
Drawn Cup Roller Clutches for Use in Plastic Housings	B-140



DRAWN CUP ROLLER CLUTCHES METRIC AND INCH SERIES

Drawn cup roller clutch transmits torque between shaft and housing in one direction and allows free overrun in the opposite direction. When transmitting torque, either the shaft or the housing can be the input member. Applications are generally described as indexing, backstopping or overrunning.

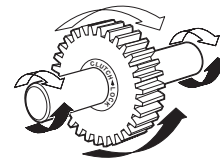

Fig. B-18. Lock function: shaft drives gear clockwise (white arrows) or gear can drive shaft counterclockwise (black arrows)

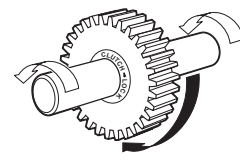

Fig. B-19. Overrun function: shaft overruns in gear counterclockwise (white arrows) or gear overruns on shaft clockwise (black arrow)

IDENTIFICATION

The prefix letters in the designation of the drawn cup roller clutches and drawn cup roller clutch and bearing assemblies denote whether these are manufactured to metric or inch nominal dimensions. Designation codes for clutches and clutch and bearing assemblies with metric nominal dimensions begin with the letter "F." Designation codes for clutches and clutch and bearing assemblies with inch nominal dimensions begin with the letter "R."

The basic types of clutches and clutch and bearing assemblies are listed below:

METRIC SERIES TYPES

- FCS, FC-K** Regular clutch, single roller per stainless steel spring.
- FC** Regular clutch, multi-roller per stainless steel spring.
- FCB** Regular clutch and bearing assembly, multi-roller per stainless steel spring.
- FCL-K** Light series clutch, single roller per stainless steel spring.
- FCBL-K, FCBN-K** Light series clutch and bearing assembly. Single roller per stainless steel spring.

INCH SERIES TYPES

- RC** Regular clutch, single roller per integral spring.
- RC-FS** Regular clutch, single roller per stainless steel spring.
- RCB** Regular clutch and bearing assembly, single roller per integral spring.
- RCB-FS** Regular clutch and bearing assembly, single roller per stainless steel spring.

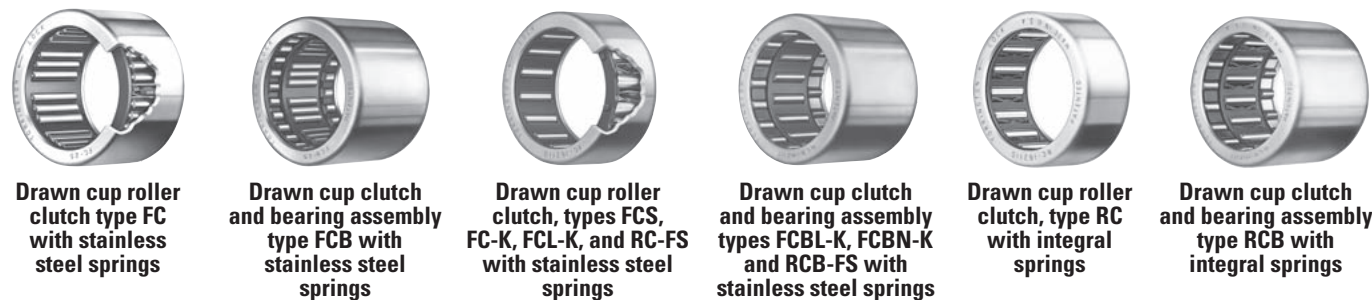

Fig. B-20. Types of clutches and clutch and bearing assemblies

CONSTRUCTION

In many respects, construction is similar to that of drawn cup bearings. Design and manufacture of drawn cup clutches – just as with drawn cup bearings – was pioneered and developed by The Torrington Company. The well-established design utilizes the same low-profile radial section as drawn cup bearings. The precisely formed interior ramps provide surfaces against which the needle rollers wedge. These positively lock the clutch with the shaft when rotated in the proper direction. These ramps, formed during the operation of drawing the cup, are case hardened for wear resistance. The incorporation of ramp forming into the cup drawing operation is a manufacturing innovation that contributes to the low cost of the unit.

Two designs of precision molded clutch cages are employed. Clutch and clutch and bearing assembly types – FC, FC-K, FCS, FCL-K, RC-FS, FCB, FCBN-K, FCBL-K and RCB-FS – use a glass fiber, reinforced nylon cage, equipped with inserted stainless steel leaf springs. The stainless steel springs permit higher rates of clutch engagement and achieve greater spring life. The nylon cage permits operation at higher temperatures. Clutch types RC and RCB utilize a one-piece cage of acetyl resin polymer with integral leaf style springs. They are used for lower temperatures than permitted for the units with nylon cages.

OPERATION

Operation is in two modes: the overrun mode and the lock mode. Operational mode is controlled by the direction of the clutch or shaft rotation with respect to the locking ramps.

In the overrun mode, shown in the drawings below, the relative rotation between the housed clutch and the shaft causes the rollers to move away from their locking position against the locking ramps in the drawn cup. The housing and the clutch are then free to overrun in one direction, or the shaft is free to overrun in the other direction.

Types FCB, FCBL-K, FCBN-K, RCB and RCB-FS clutch and bearing assemblies have cages, for retention and guidance of the needle rollers in the bearings, located on both sides of the clutch unit.



Fig. B-21. Clutch and bearing assembly

Types FC, FC-K, FCS, FCL-K, RC and RC-FS are of clutch-only configurations for use with external radial support (usually two drawn cup needle roller bearings). Separate bearings position the shaft and housing concentrically and carry the radial load during overrun.



Fig. B-22. Clutch only

In the lock mode, shown in the drawings below, the relative rotation between the housed clutch and the shaft is opposite to that in the overrun mode. The rollers, assisted by the leaf-type springs, become wedged between the locking ramps and the shaft to transmit torque between the two members. Either the member housing the clutch drives the shaft in one direction, or the shaft can drive the clutch and its housing member in the other direction.

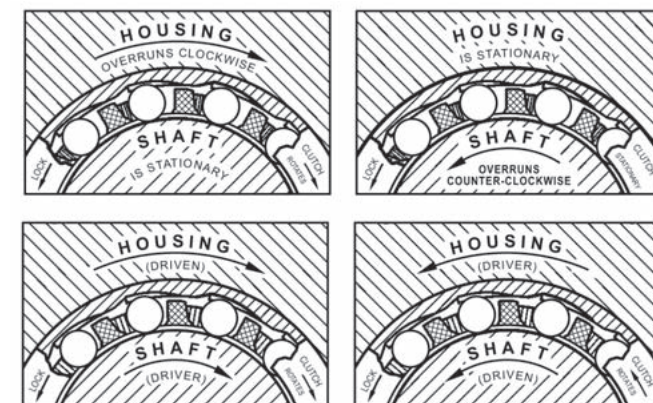

Clearance between the rollers and cup ramps is exaggerated in these drawings.

Fig. B-23. Overrun mode and lock mode



APPLICATION

Clutches and clutch and bearing assemblies are successfully applied in a wide range of commercial products where indexing, backstopping and overrunning operations must be performed reliably. The sketches on these pages illustrate some of the many possible uses.

When applying the clutch-only unit, separate bearings on each side of the clutch are required to position the shaft concentrically with the housing, and to carry the radial loads during overrun. Drawn cup needle roller bearings, with the same radial section as the clutch, should be used in the through-bored housings for simplicity and economy. Two clutches can be used side by side for greater torque capacity.

Where the radial loads are light, the clutch and bearing assembly can be used without additional support bearings. This reduces the overall assembly width, the number of stocked and ordered parts and assembly costs, as well.



Fig. B-24. Clutch and bearing arrangement for heavy loads

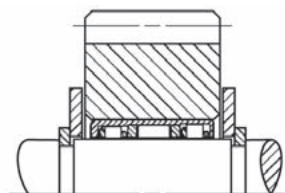

Fig. B-25. Clutch and bearing assembly for light loads

Drawn cup roller clutches are manufactured to commercial hardware standards and are used extensively in appliances, business machines, industrial and recreation equipment and a wide range of other applications.

In any application where our clutch may be considered, it will be part of a system in which the operating conditions and the clutch mounting will affect its function. Before any clutch selection is made, it is important that the following catalog section be carefully studied to understand the effects of these factors. Consideration should be given to operating conditions such as:

- Magnitude of externally applied torque, as well as inertial torque.
- Magnitude of applied radial loads during overrunning.
- Potential for vibration or axial shaft movement within the clutch during engagement.
- Engagement rate, as it pertains to the selection of stainless steel or plastic leaf springs.
- Oil lubricant supply during high overrunning speeds.
- External and internal environmental temperatures that can affect clutch performance.
- Lubricant selection effect on clutch engagement.
- Indexing inaccuracies resulting from backlash (lost motion).

Consideration should be given to the shaft and housing design requirements such as:

- Shaft hardness and strength particularly when approaching torque rating limits.
- Shaft roundness, taper and surface finish necessary to ensure sufficient fatigue life and torque-carrying ability.
- Housing strength (hardness and cross section) to support the applied torque loads.
- Housing roundness, taper and surface finish necessary to ensure uniform torque and load distribution.

A test program under all expected operating conditions should be carried out before putting a new application into production. Customer engineers are constantly working with and testing new applications, and their experience can be of great help to the designer considering the use of a drawn cup roller clutch.

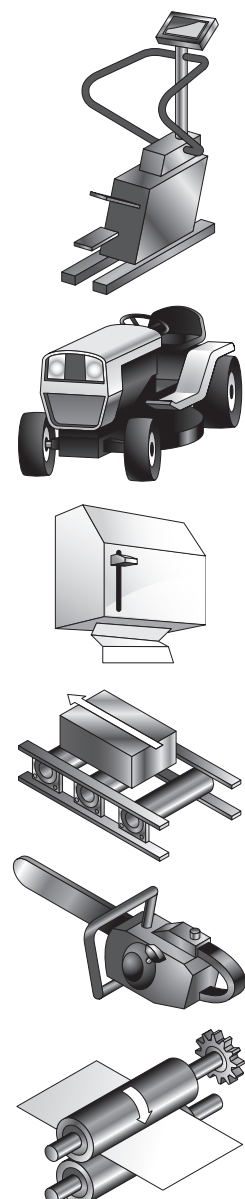

Stair steppers and other athletic equipment

Lawnmower differential

Towel dispensers and similar web roll feed mechanisms

Conveyor rollers

Chainsaw starters

Paper feed rolls in business machines

Fig. B-26(1). Drawn cup clutches and clutch and bearing assembly applications

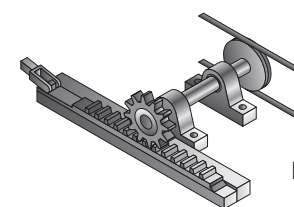

Rack indexing drive

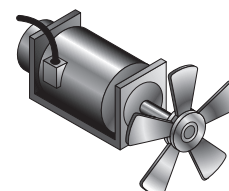

Motor backstops

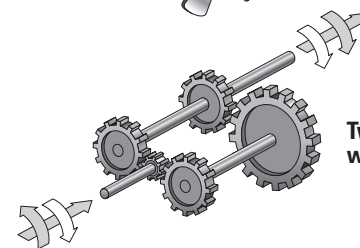

Two-speed gearbox with reversing input

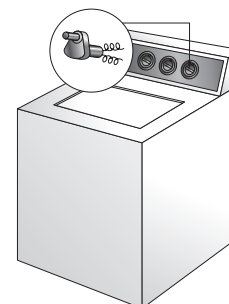

Timing motor freewheels

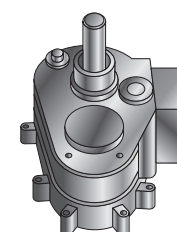

Washing machine transmission

Fig. B-26(2). Drawn cup clutches and clutch and bearing assembly applications

HOUSING DESIGN

Drawn cup clutches and clutch and bearing assemblies are mounted with a simple press fit in their housings. Through-bored and chamfered housings are preferred. A 30 degree angle is suggested and care should be taken to round the edge where the chamfer meets the housing bore. A sharp edge at this location can greatly increase installation forces. Provisions for axial location, such as shoulders or snap rings, are not required. The case hardened cups must be properly supported. Steel housings are preferred and must be used for applications involving high-torque loads to prevent radial expansion of the clutch cups. The suggested minimum housing outer diameters in the tables of dimensions are for steel.

The housing bore should be round within one-half of the diameter tolerance.

The taper within the length of the outer ring should not exceed 0.013 mm (0.0005 in).

The surface finish of the housing bore should not exceed 1.6 µm Ra (63 µin Ra).

The torque ratings, given in the clutch tables, are based on a steel housing of a large section. When other housing material must be used (such as aluminum, powdered metal and plastics), the torque rating of the clutch will be reduced. Such housings may be satisfactory for lightly torqued applications. But, your representative should be consulted for appropriate housing and shaft suggestions. Otherwise, an insufficient press fit and use of a lower strength housing material can result in more internal clearance and reduced performance of the clutch.

When using non-steel housings, thorough testing of the design is suggested.

Adhesive compounds can be used to prevent creeping rotation of the clutch in plastic housings with low friction properties. Adhesives will not provide proper support in oversized metal housings. When using adhesives, care must be taken to keep the adhesive out of the clutches and bearings.

SHAFT DESIGN

The clutch or clutch and bearing assembly operates directly on the shaft whose specifications of dimension, hardness and surface finish are well within standard manufacturing limits.

Either case-hardening or through-hardening grades of good bearing-quality steel are satisfactory for raceways. Steels modified for free machining, such as those high in sulfur content and particularly those containing lead, are seldom satisfactory for raceways.

For long fatigue life, the shaft raceway must have a hardness equivalent to 58 HRC minimum and must be ground to the suggested diameter shown in the tables of dimensions. It may be through-hardened, or it may be case hardened with an effective case depth of 0.40 mm (0.015 in). Effective case depth is defined as the distance from the surface inward to the equivalent of 50 HRC hardness level after grinding.

Taper within the length of the raceway should not exceed 0.008 mm (0.0003 in), or one-half the diameter tolerance – whichever is smaller. The radial deviation from true circular form of the raceway should not exceed 0.0025 mm (0.0001 in) for diameters up to and including 25 mm (1.0 in). For raceways greater than 25 mm (1.0 in), the allowable radial deviation should not exceed 0.0025 mm (0.0001 in) multiplied by a factor of the raceway diameter divided by 25 (1.0 in). Surface finish on the raceway should not exceed 0.4 µm (16 µin) Ra. Deviations will reduce the load capacity and fatigue life of the shaft.



INSTALLATION

Simplicity of installation promotes additional cost savings. The drawn cup roller clutch or the clutch and bearing assembly must be pressed into its housing. Procedures are virtually identical with those for installing drawn cup bearings, as detailed on pages B-48 and B-90. The unit is pressed into the bore of a gear or pulley hub or housing of the proper size. No shoulders, splines, keys, screws or snap rings are required.

Installation procedures are summarized in the following sketches:

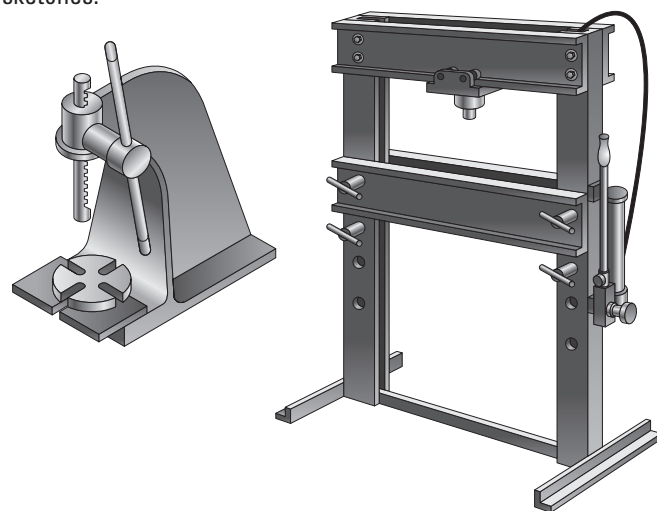

Fig. B-27. Arbor press and hydraulic ram press

Use an arbor press or hydraulic ram press to exert steady pressure. Never use a hammer, or other tool requiring pounding to drive the clutch into its housing.

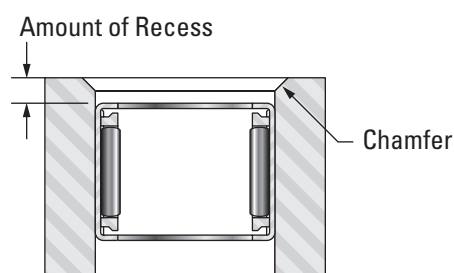

Fig. B-28. Chamfered housing bore

Make sure that the housing bore is chamfered to permit easy introduction of the clutch and bearing or the clutch unit. Press unit slightly beyond the chamfer in the housing bore to assure full seating. Through-bored housings are always preferred. If the housing has a shoulder, never seat the clutch against the shoulder. For further details, see pages B-48 and B-90.



Fig. B-29. Lock marking

IMPORTANT: The mounted clutch or clutch and bearing assembly engages when the housing is rotated relative to the shaft in the direction of the arrow and lock marking (← LOCK) stamped on the cup. Make sure that the unit is oriented properly before pressing it into its housing.

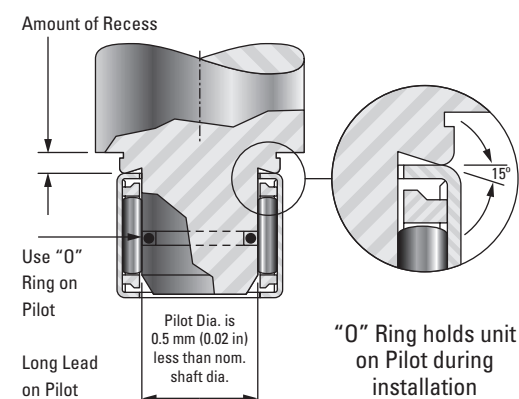

Fig. B-30. Installation tool

Use an installation tool as shown in Fig. B-30. If the clutch is straddled by needle roller bearings, press units into position – in proper sequence – and preferably leave a small clearance between units.

When assembling the shaft, it should be rotated in the overrun direction during insertion. The end of the shaft should have a large chamfer or rounding.

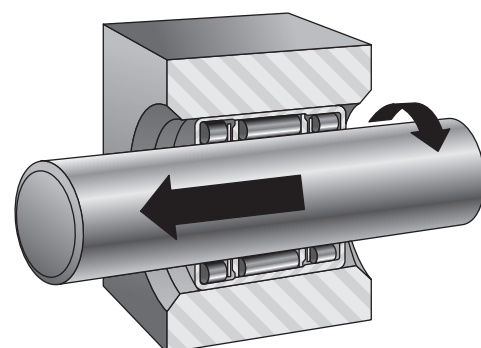

Fig. B-31. Rotate shaft in the overrun direction during insertion

APPLIED LOADS

The clutch-only unit is designed to transmit purely torque loads. Applied torque should not exceed the catalog ratings, which are based on the compressive strength of well-aligned clutch components. Bearings on either side of the clutch are to assure concentricity between the shaft and the housing to support radial loads during clutch overrun. Integral clutch and bearing assemblies are available for this purpose, especially where the radial loads are light. The total maximum dynamic radial load that may be shared by the two needle roller and cage radial bearing assemblies should not be greater than C/3.

In determining the total torque load on a clutch, it is essential to consider the torque, due to inertial forces developed in the mechanism, in addition to the externally applied torque. The larger the clutch, and the greater the mass of the mechanism controlled by it, the more important this consideration becomes.

Clutch lockup depends on friction. For this reason, applications involving severe vibrations or axial motion of the shaft within the clutch are to be avoided. Applications where overhanging or overturning loads occur should incorporate bearings that will maintain alignment between the shaft and the clutch housing. Consult your representative for suggestions.

LUBRICATION

Oil is the preferred lubricant; it minimizes wear and heat generation. For those applications where oil is not practical, clutches are packed with a soft grease containing mineral oil. Thick grease will retard roller engagement and can cause individual rollers to slip, possibly overloading any engaged rollers.

TEMPERATURE

Temperature extremes can cause clutch malfunctions and failure. The molded plastic cage with integral springs holds its necessary resiliency and strength when the operating temperature within the clutch is kept below 90° C (200° F). The clutch with reinforced nylon cage and separate steel springs operates well at temperatures up to 120° C (250° F) continuously and to 150° C (300° F) intermittently. Excessive thickening of the lubricant at low temperatures may prevent some, or all, of the rollers from engaging. New applications should be tested under expected operating conditions to determine whether or not temperature problems exist.

BACKLASH

Backlash, or lost motion, prior to engagement is minimal. The variation in backlash from one cycle to another is extremely low. Grease lubrication, or improper fit (housing bore and shaft diameter), may increase backlash. Angular displacement between the shaft and housing increases as an applied torque load is increased.

RATE OF ENGAGEMENT

Clutch lockup depends upon static friction. Axial motion between shaft and clutch rollers prevents lockup.

Clutches with integral springs engage satisfactorily at cyclic rates up to 200 engagements per minute. Intermittent operation at higher rates has been successful. The steel spring type clutches have proven dependability at rates up to 6000 or 7000 engagements per minute. Even higher cyclic rates may be practical. Because grease may impair engagement at high cyclic rates, a light oil should be used.

OVERRUN LIMIT SPEED RATING

Exact limiting speed ratings are not easily predictable. The value for each clutch given in the bearing tables is not absolute but serves as a guide for the designer. Oil lubrication is absolutely necessary for high speed operations. Consult your representative when overrunning speeds are high.

INSPECTION

Although the outer cup of the clutch is accurately drawn from strip steel, it can go slightly out of round during heat treat. When the assembly is pressed into a ring gage, or properly prepared housing of correct size and wall thickness, it becomes round and properly sized. Direct measurement of the outer diameter of a drawn cup assembly is an incorrect procedure. The proper inspection procedure is as follows:

1. Press the assembly into a ring gage of the proper size, as given in the tables.
2. Gage the bore with the specified plug gages of the proper size, as given in the tables of dimensions.
 - a. The locking plug is rotated to ensure lockup when the clutch is operated on a low-limit shaft and is mounted in a high-limit housing, strong enough to properly size the clutch.
 - b. The overrun plug is rotated to ensure free overrunning when the clutch is operated on a high-limit shaft and is mounted in a low-limit housing.
 - c. The “go” plug and “no go” plug ensure proper size of the bearings in the clutch and bearing assemblies.

Gage sizes are listed in the tables of dimensions. Plug gage sizes reflect adjustment for the loose and tight conditions resulting from high or low housings or shafts.



DRAWN CUP ROLLER CLUTCHES

METRIC SERIES

- For proper application, separate bearings are suggested (adjacent to clutch) to carry radial loads and assure concentricity between shaft and housing.
- The clutch engages when housing is rotated relative to the shaft in direction of arrow marking (← LOCK), as labeled on cup.
- Proper inspection requires use of ring gage and bore plug gage(s). See the inspection section on page B-131.
- Full details on installation are given on page B-130.

- Shaft raceway and housing bore diameters that are necessary for proper mounting and operation are listed on the opposite page.

- Types FC, FCS, FC-K and FCL-K clutches have stainless steel springs inserted in molded cage to position rollers for lockup.



The mounted clutch engages when the housing is rotated relative to the shaft in the direction of the arrow marking (← LOCK) stamped on the cup.

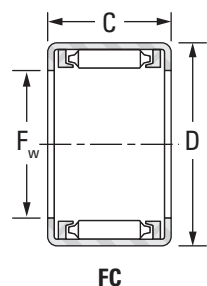

FC

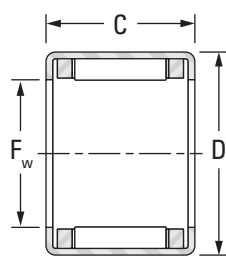

FCS, FCL-K and FC-K

Shaft Diameter	F _w	D	C	Clutch Designation	Torque Rating	Z	Overrun Limiting Speed Rating for Rotating Shaft	Suitable Drawn Cup Bearing ⁽¹⁾
						Minimum O.D. of Steel Housing for Rated Torque		
mm in	mm in	mm in	mm in		N-m lbf-in	mm in	min ⁻¹	
4 0.1575	4 0.1575	8 0.3150	6 0.236	FC-4-K	0.349 3.09	11 0.433	26000	HK0408
6 0.2362	6 0.2362	10 0.3937	12 0.472	FCS-6	2.15 19.0	14 0.551	22000	HK0608
	6 0.2362	10 0.3937	12 0.472	FC-6	2.63 23.3	14 0.551	22000	HK0608
8 0.3150	8 0.3150	12 0.4724	12 0.472	FCL-8-K	3.39 30.0	17 0.669	21000	HK0808
	8 0.3150	14 0.5512	12 0.472	FC-8	4.42 39.1	20 0.787	21000	—
10 0.3937	10 0.3937	14 0.5512	12 0.472	FCL-10-K	4.60 40.7	20 0.787	19000	HK1010
	10 0.3937	16 0.6299	12 0.472	FC-10	5.82 51.5	25 0.984	19000	—
12 0.4724	12 0.4724	18 0.7087	16 0.630	FC-12	14.0 124	27 1.063	19000	HK1212
16 0.6299	16 0.6299	22 0.8661	16 0.630	FC-16	21.7 192	31 1.22	14000	HK1612
20 0.7874	20 0.7874	26 1.0236	16 0.630	FC-20	32.6 289	38 1.496	11000	HK2012
	20 0.7874	26 1.0236	16 0.630	FC-20-K	30.0 266	38 1.496	11000	HK2012
25 0.9843	25 0.9843	32 1.2598	20 0.787	FC-25-K	66.4 588	46 1.811	8700	HK2512
	25 0.9843	32 1.2598	20 0.787	FC-25	71.0 628	46 1.811	8700	HK2512
30 1.1811	30 1.1811	37 1.4567	20 0.787	FC-30	99.1 877	51 2.008	7300	HK3012
35 1.3780	35 1.3780	42 1.6535	20 0.787	FCS-35	107.0 947	56 2.205	6100	HK3512

⁽¹⁾ See pages B-50 to B-59 for suitable bearing types and sizes.

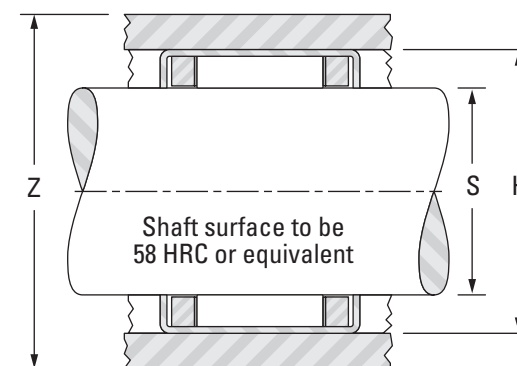

Gaging			S		H		Approx. Wt.
Ring Gage	Clutch Locking Plug	Clutch Overrun Plug	Shaft Raceway Diameter		Housing Bore		
			Mounting		Max.	Min.	
mm in	mm in	mm in	mm in	mm in	mm in	mm in	kg lbs
7.984 0.3143	3.980 0.1567	4.004 0.1576	4.000 0.1575	3.995 0.1573	7.993 0.3147	7.984 0.3143	0.001 0.002
9.984 0.3931	5.980 0.2354	6.004 0.2364	6.000 0.2362	5.995 0.2360	9.993 0.3934	9.984 0.3931	0.003 0.007
9.984 0.3931	5.980 0.2354	6.004 0.2364	6.000 0.2362	5.995 0.2360	9.993 0.3934	9.984 0.3931	0.004 0.009
11.980 0.4717	7.976 0.3140	8.005 0.3152	8.000 0.3150	7.994 0.3147	11.991 0.4721	11.980 0.4717	0.003 0.007
13.980 0.5504	7.976 0.3140	8.005 0.3152	8.000 0.3150	7.994 0.3147	13.991 0.5508	13.980 0.5504	0.007 0.015
13.980 0.5504	9.976 0.3928	10.005 0.3939	10.000 0.3937	9.994 0.3935	13.991 0.5508	13.980 0.5504	0.004 0.009
15.980 0.6291	9.976 0.3928	10.005 0.3939	10.000 0.3937	9.994 0.3935	15.991 0.6296	15.980 0.6291	0.009 0.020
17.980 0.7079	11.974 0.4714	12.006 0.4727	12.000 0.4724	11.992 0.4721	17.991 0.7083	17.980 0.7079	0.012 0.026
21.976 0.8652	15.972 0.6288	16.006 0.6302	16.000 0.6299	15.992 0.6296	21.989 0.8657	21.976 0.8652	0.018 0.040
25.976 1.0227	19.970 0.7862	20.007 0.7877	20.000 0.7874	19.991 0.7870	25.989 1.0232	25.976 1.0227	0.021 0.046
25.976 1.0227	19.970 0.7862	20.007 0.7877	20.000 0.7874	19.991 0.7870	25.989 1.0232	25.976 1.0227	0.016 0.035
31.972 1.2587	24.967 0.9830	25.007 0.9845	25.000 0.9843	24.991 0.9839	31.988 1.2594	31.972 1.2587	0.026 0.057
31.972 1.2587	24.967 0.9830	25.007 0.9845	25.000 0.9843	24.991 0.9839	31.988 1.2594	31.972 1.2587	0.034 0.075
36.972 1.4556	29.967 1.1798	30.007 1.1814	30.000 1.1811	29.991 1.1807	36.988 1.4562	36.972 1.4556	0.042 0.093
41.972 1.6524	34.964 1.3765	34.009 1.3389	35.000 1.3780	34.989 1.3775	41.988 1.6531	41.972 1.6524	0.048 0.106



DRAWN CUP ROLLER CLUTCHES AND BEARING ASSEMBLIES

METRIC SERIES

- The clutch and bearing assembly engages when the housing is rotated relative to shaft in direction of arrow marking (← LOCK), as labeled on cup.
- Shaft raceway and housing bore diameters that are necessary for proper mounting and operation are listed on the opposite page.
- Proper inspection requires use of ring gage and bore plug gage(s). See the inspection section on page B-131.

- Full details on installation are given on page B-130.
- Types FCB, FCBL-L and FCBN-K clutch and bearing assemblies have stainless steel springs inserted in molded cage to position rollers for lockup.



The mounted clutch and bearing assembly engages when the housing is rotated relative to the shaft in the direction of the arrow marking (← LOCK) stamped on the cup.

Clutch and bearing assemblies

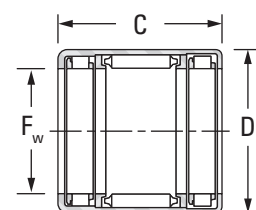

FCB

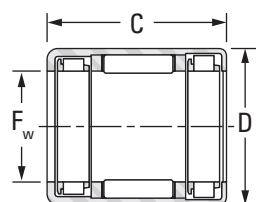

FCBL-K and FCBN-K

Shaft Diameter	F _w	D	C	Clutch and Bearing Assembly Designation	Torque Rating	Z	Load Ratings ⁽¹⁾		Overrun Limiting Speed Rating for Rotating Shaft	
							Minimum O.D. of Steel Housing for Rated Torque	C		C ₀
								Dynamic		Static
mm in	mm in	mm in	mm in		N-m lbf-in		kN lbf	kN lbf	min ⁻¹	
4 0.1575	4 0.1575	10 0.3937	9 0.354	FCBN-4-K	0.19 1.68	16 0.630	1.86 418	0.99 223	26000	
6 0.2362	6 0.2362	12 0.4724	10 0.394	FCBN-6-K	0.56 4.96	18 0.709	2.48 558	1.48 333	22000	
8 0.3150	8 0.3150	12 0.4724	22 0.866	FCBL-8-K	3.39 30.0	17 0.669	3.62 814	3.28 737	21000	
	8 0.3150	14 0.5512	20 0.787	FCB-8	4.42 39.1	20 0.787	4.22 949	3.04 683	21000	
10 0.3937	10 0.3937	16 0.6299	20 0.787	FCB-10	5.82 51.5	25 0.984	4.84 1090	3.80 854	19000	
12 0.4724	12 0.4724	18 0.7087	26 1.024	FCB-12	14.0 124	27 1.063	6.30 1420	5.84 1310	19000	
16 0.6299	16 0.6299	22 0.8661	26 1.024	FCB-16	21.7 192	31 1.220	6.64 1490	7.12 1600	14000	
20 0.7874	20 0.7874	26 1.0236	26 1.024	FCB-20	32.6 289	38 1.496	8.16 1830	9.46 2130	11000	
25 0.9843	25 0.9843	32 1.2598	30 1.181	FCB-25	71.0 628	46 1.811	11.3 2540	13.1 2940	8700	
30 1.1811	30 1.1811	37 1.4567	30 1.181	FCB-30	99.1 877	51 2.008	11.5 2590	14.9 3350	7300	

⁽¹⁾ Load ratings are based on a minimum raceway hardness of 58 HRC or equivalent.

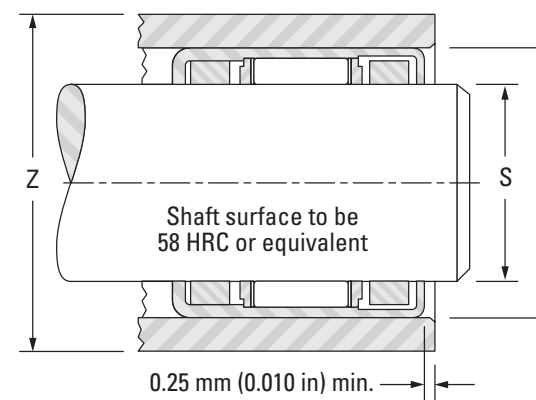

Gaging				S		H		Approx. Wt.
Ring Gage	Clutch Locking Plug	Clutch Overrun and Bearing Go Plug	Bearing No Go Plug	Mounting				
				Max.	Min.	Max.	Min.	
mm in	mm in	mm in	mm in	mm in	mm in	mm in	mm in	kg lbs
9.984 0.3931	3.980 0.1567	4.004 0.1576	4.030 0.1587	4.000 0.1575	3.995 0.1573	9.993 0.3934	9.984 0.3931	0.003 0.007
11.980 0.4717	5.977 0.2353	6.004 0.2364	6.030 0.2374	6.000 0.2362	5.995 0.2360	11.991 0.4721	11.980 0.4717	0.004 0.009
11.980 0.4717	7.976 0.3140	8.005 0.3152	8.033 0.3163	8.000 0.3150	7.994 0.3147	11.991 0.4721	11.980 0.4717	0.005 0.011
13.980 0.5504	7.976 0.3140	8.005 0.3152	8.033 0.3163	8.000 0.3150	7.994 0.3147	13.991 0.5508	13.980 0.5504	0.011 0.024
15.980 0.6291	9.976 0.3928	10.005 0.3939	10.033 0.3950	10.000 0.3937	9.994 0.3935	15.991 0.6296	15.980 0.6291	0.013 0.029
17.980 0.7079	11.974 0.4714	12.006 0.4727	12.036 0.4739	12.000 0.4724	11.992 0.4721	17.991 0.7083	17.980 0.7079	0.018 0.040
21.976 0.8652	15.972 0.6288	16.006 0.6302	16.036 0.6313	16.000 0.6299	15.992 0.6296	21.989 0.8657	21.976 0.8652	0.024 0.053
25.976 1.0227	19.970 0.7862	20.007 0.7877	20.043 0.7891	20.000 0.7874	19.991 0.7870	25.989 1.0232	25.976 1.0227	0.028 0.062
31.972 1.2587	24.967 0.9830	25.007 0.9845	25.043 0.9859	25.000 0.9843	24.991 0.9839	31.988 1.2594	31.972 1.2587	0.048 0.106
36.972 1.4556	29.967 1.1798	30.007 1.1814	30.043 1.1828	30.000 1.1811	29.991 1.1807	36.988 1.4562	36.972 1.4556	0.054 0.119



DRAWN CUP ROLLER CLUTCHES

INCH SERIES

- For proper application, separate bearings are suggested (adjacent to clutch) to carry radial loads and assure concentricity between shaft and housing.
- The clutch engages when housing is rotated relative to the shaft in direction of arrow marking (← LOCK), as labeled on cup.
- Proper inspection requires use of ring gage and bore plug gage(s). See the inspection section on page B-131.
- Full details on installation are given on page B-130.

- Shaft raceway and housing bore diameters that are necessary for proper mounting and operation are listed on the opposite page.
- Clutch have spring integrally molded (type RC) stainless steel springs inserted (type RC-FS) in molded cage to position rollers for lockup.



The mounted clutch engages when the housing is rotated relative to the shaft in the direction of the arrow marking (← LOCK) stamped on the cup.

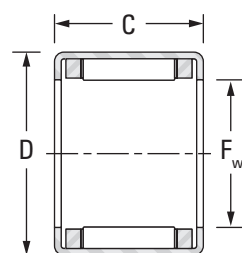

RC and RC-FS

Shaft Diameter	F _w	D	C -0.25 mm -0.010 in	Clutch and Bearing Designations		Torque Rating	Z Minimum O.D. of Steel Housing for Rated Torque	Overrun Limiting Speed Rating for Rotating Shaft
				With Stainless Steel Springs	With Integral Springs			
mm in	mm in	mm in	mm in			N-m lbs-in		min ⁻¹
3.175 0.1250	3.18 0.125	7.14 0.281	6.35 0.250	—	RC-02	0.323 2.86	11.2 0.44	34000
6.350 0.2500	6.35 0.250	11.13 0.438	12.70 0.500	RC-040708-FS ⁽¹⁾	RC-040708	1.94 17.2	15.7 0.62	20000
9.525 0.3750	9.53 0.375	15.88 0.625	12.70 0.500	RC-061008-FS ⁽¹⁾	RC-061008	5.45 48.2	22.4 0.88	18000
12.700 0.5000	12.70 0.500	19.05 0.750	12.70 0.500	RC-081208-FS ⁽¹⁾	RC-081208	8.85 78.3	27.9 1.10	17000
15.875 0.6250	15.88 0.625	22.23 0.875	15.88 0.625	RC-101410-FS ⁽¹⁾	RC-101410	16.8 149	30.5 1.20	14000
19.050 0.7500	19.05 0.750	25.40 1.000	15.88 0.625	RC-121610-FS ⁽¹⁾	RC-121610	23.3 206	35.6 1.40	12000
25.400 1.0000	25.40 1.000	33.35 1.313	15.88 0.625	RC-162110-FS ⁽¹⁾	RC-162110	49.6 439	48.3 1.90	8700

⁽¹⁾ Suffix "-FS" is not always stamped on the clutch cup. Type RC-FS with stainless steel springs is always readily identified by RED clutch cage.
⁽²⁾ See pages B-110 to B-117 for other suitable bearing types and sizes.

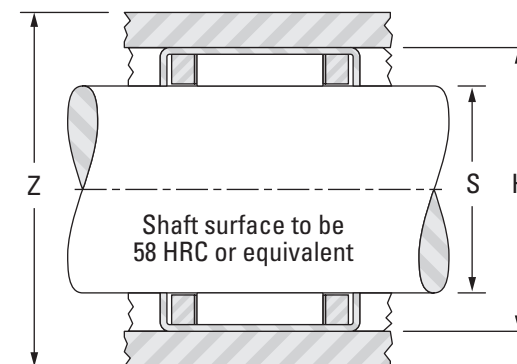

Suitable Drawn Cup Bearing ⁽²⁾	Gaging			S		H		Approx. Wt.
	Ring Gage	Clutch Locking Plug	Clutch Overrun Plug	Shaft Raceway Diameter				
				Housing Bore				
				Mounting				
				Max.	Min.	Max.	Min.	
	mm in	mm in	mm in	mm in	mm in	mm in	mm in	kg lbs
—	7.155 0.2817	3.160 0.1244	3.195 0.1258	3.175 0.1250	3.167 0.1247	7.155 0.2817	7.142 0.2812	0.001 0.002
J-45	11.125 0.4380	6.337 0.2495	6.383 0.2513	6.350 0.2500	6.337 0.2495	11.125 0.4380	11.100 0.4370	0.004 0.008
JH-68	15.888 0.6255	9.512 0.3745	9.558 0.3763	9.525 0.3750	9.512 0.3745	15.888 0.6255	15.862 0.6245	0.008 0.017
JH-87	19.063 0.7505	12.687 0.4995	12.733 0.5013	12.700 0.5000	12.687 0.4995	19.063 0.7505	19.037 0.7495	0.009 0.020
JH-1010	22.238 0.8755	15.862 0.6245	15.908 0.6263	15.875 0.6250	15.862 0.6245	22.238 0.8755	22.212 0.8745	0.014 0.030
J-126	25.387 0.9995	19.012 0.7485	19.058 0.7503	19.050 0.7500	19.037 0.7495	25.413 1.0005	25.387 0.9995	0.015 0.034
JH-1612	33.325 1.3120	25.362 0.9985	25.408 1.0003	25.400 1.0000	25.387 0.9995	33.350 1.3130	33.325 1.3120	0.026 0.058



DRAWN CUP ROLLER CLUTCH AND BEARING ASSEMBLIES INCH SERIES

- Clutch and bearing assembly engages when the housing is rotated relative to shaft in direction of arrow marking (← LOCK), as labeled on cup.
- Shaft raceway and housing bore diameters that are necessary for proper mounting and operation are listed on the opposite page.
- Proper inspection requires use of ring gage and bore plug gage(s). See the inspection section on page B-131.

- Full details on installation are given on page B-130.
- Clutch and bearing assemblies have spring integrally molded (type RCB) stainless steel springs inserted (type RCB-FS) in molded cage to position rollers for lockup.



The mounted clutch and bearing assemblies engages when the housing is rotated relative to the shaft in the direction of the arrow marking (← LOCK) stamped on the cup.

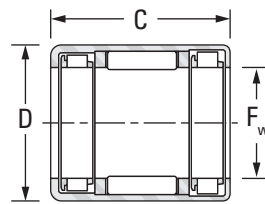

RCB and RCB-FS

Shaft Diameter	F _w	D	C -0.25 mm -0.010 in	Clutch and Bearing Designations		Torque Rating	Z Minimum O.D. of Steel Housing for Rated Torque	Load Ratings ⁽¹⁾		Overrun Limiting Speed Rating for Rotating Shaft
				With Stainless Steel Springs	With Integral Springs			C	C ₀	
9.525 0.3750	9.53 0.375	15.88 0.625	22.23 0.875	RCB-061014-FS ⁽¹⁾	RCB-061014	5.45 48.2	22.4 0.88	6.01 1350	4.89 1100	18000
12.700 0.5000	12.70 0.500	19.05 0.750	22.23 0.875	RCB-081214-FS ⁽¹⁾	RCB-081214	8.85 78.3	27.9 1.1	7.12 1600	6.49 1460	17000
15.875 0.6250	15.88 0.625	22.23 0.875	25.40 1.000	RCB-101416-FS ⁽¹⁾	RCB-101416	16.8 149	30.5 1.2	8.05 1810	8.14 1830	14000
19.050 0.7500	19.05 0.750	25.40 1.000	25.40 1.000	RCB-121616-FS ⁽¹⁾	RCB-121616	23.3 206	35.6 1.4	8.90 2000	9.79 2200	12000
25.400 1.0000	25.40 1.000	33.35 1.313	27.00 1.063	RCB-162117-FS ⁽¹⁾	RCB-162117	49.6 439	48.3 1.9	15.4 3460	17.6 3960	8700

⁽¹⁾ Suffix "-FS" is not always stamped on the clutch cup. Type RC-FS with stainless steel springs is always readily identified by RED clutch cage.

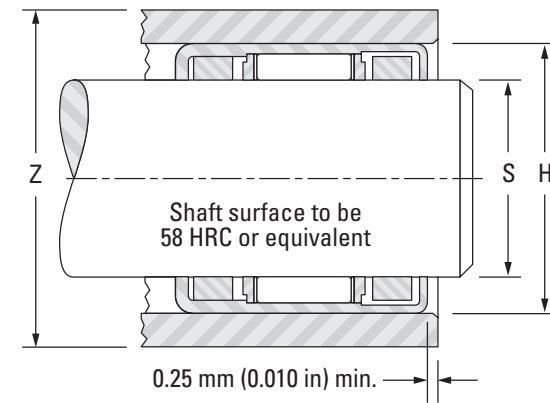

Gaging				S		H		Approx. Wt.
Ring Gage	Clutch Locking Plug	Clutch Overrun and Bearing Go Plug	Bearing No Go Plug	Shaft Raceway Diameter		Housing Bore		
				Mounting				
				Max.	Min.	Max.	Min.	
15.888 0.6255	9.512 0.3745	9.553 0.3761	9.589 0.3775	9.525 0.3750	9.512 0.3745	15.888 0.6255	15.862 0.6245	0.014 0.030
19.063 0.7505	12.687 0.4995	12.728 0.5011	12.764 0.5025	12.700 0.5000	12.687 0.4995	19.063 0.7505	19.037 0.7495	0.016 0.036
22.238 0.8755	15.862 0.6245	15.903 0.6261	15.939 0.6275	15.875 0.6250	15.862 0.6245	22.238 0.8755	22.212 0.8745	0.023 0.050
25.387 0.9995	19.012 0.7485	19.053 0.7501	19.088 0.7515	19.050 0.7500	19.037 0.7495	25.413 1.0005	25.387 0.9995	0.026 0.057
33.325 1.3120	25.362 0.9985	25.403 1.0001	25.438 1.0015	25.400 1.0000	25.387 0.9995	33.350 1.3130	33.325 1.3120	0.045 0.100



INTRODUCTION

OTHER AVAILABLE CLUTCHES

In addition to the metric and inch sizes of drawn cup clutches and clutch and bearing assemblies already discussed, JTEKT offers other types of drawn cup clutches to address special customer needs:

DRAWN CUP ROLLER CLUTCHES FOR USE IN PLASTIC HOUSINGS

FCP AND DF TYPES

Types **FCP** and **DF** clutches feature axial grooves in the outside surface of the clutch cup. It is important that these grooves align with similar protrusions in the housing bore to prevent the clutch from slipping relative to the housing.

Types **FCP** and **DF** clutches are available with bore diameters of 4, 6, 8 and 10 mm.

These clutches may be made available already mounted in a plastic housing such as a gear or a pulley to meet the customer's design specifications.

Please contact your representative for details and availability.

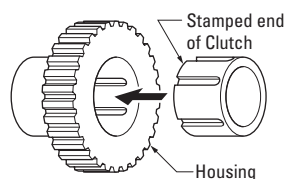

Fig. B-32. Clutch installation into housing

CHARACTERISTICS

- Easily unitized – they can be unitized with plastic parts such as gears, pulleys, rollers, etc. as needed.
- Creep preventing structure – creep is prevented by mating a thin cross section roller clutch, which has special grooves on O.D. formed by a precision press, with a plastic part that has an equal number of bosses on the bore of the housing.
- High precision and good durability – high precision and good durability is obtained because cam surfaces are formed by precision deep drawing.
- Small and compact – this series satisfies the need for a lighter compact product.

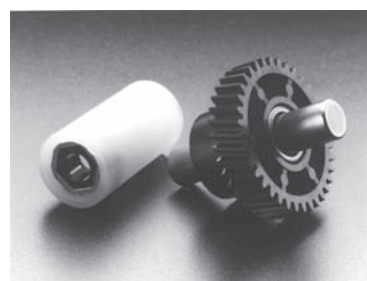

Fig. B-33. Sample DF and FCP clutches

STRUCTURE

Drawn cup roller clutches for plastic housings are composed of a drawn cup with internal cam surfaces and creep preventing grooves on O.D., rollers, and a retainer with either integral plastic or stainless steel springs.

The plastic housings can be a plastic gear, a pulley, a roller, etc., so it is possible to design the housing to meet any customers' needs.

ROLLER CLUTCH UNITS WITH PLASTIC HOUSINGS

FCU TYPES

Type **FCU** clutches were developed for office equipment and similar applications.

The **FCU** clutches are available with bore diameters of 6 and 8 mm.

They can be supplied with housings of various shapes to meet customer needs.

Please contact your representative for details and availability.

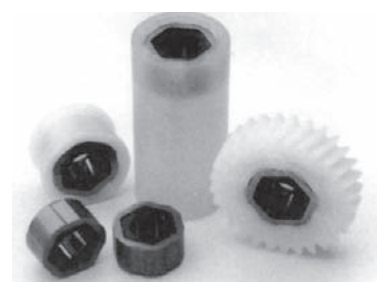

Fig. B-34. Sample of FCU clutch

RECOMMENDED FIT FOR SHAFT AND HOUSING

Drawn cup roller clutches for plastic housings are at their designed dimensions and tolerances only when they are installed in plastic housings.

- Shaft Material:
 - Carbon steel for machine structural use
 - Rolled steel for general use
 - Stainless steel
- Shaft Tolerance: h9 class
- Shaft surface finish: 0.4 micrometers
- Housing: Please consult your representative for housing bore sizes if purchasing roller clutches without housings. These roller clutches can be used with cylindrical steel or aluminum housings. In this case, please consult your representative for proper fit.

Specially designed clutches for use with plastic housings. Available in bores from 4 to 10 mm and 1/4" and 3/8" bores. Grooves drawn into cup O.D. mate with protrusions molded into plastic housing bore to prevent clutch from moving relative to plastic housing. JTEKT can supply molded plastic housing and clutch assemblies.

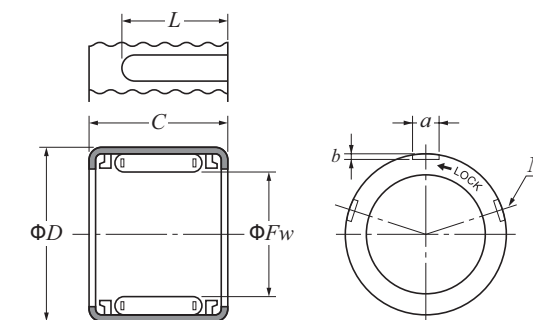

* Number of equally spaced grooves

Fig. B-35. Nominal clutch dimensions

JTEKT also has low cost FCU clutches available in 6 mm (0.2362 in) to 8 mm (0.3150 in) bores.

Can be designed and supplied with housings of various shapes to meet customer needs.

Table B-15. Drawn cup roller clutches for plastic housings

Fw	D	C	a	b	L	N	Clutch Designation	Locking ⁽¹⁾ Direction	Torque Rating (N-m)	Overrunning Drag (mN-m)	Type of Spring
mm in	mm in	mm in	mm in	mm in	mm in				N-m	mN-m	
4 0.1575	8 0.3150	6 0.2362	1.0 0.0394	0.25 0.0098	4 0.1575	5	DF-500401	CCW	0.13	1.96	Stainless Steel
	8 0.3150	6 0.2362	1.0 0.0394	0.25 0.0098	4 0.1575	5	DF-500408	CW	0.13	1.96	Stainless Steel
6 0.2362	10 0.3937	8 0.3150	1.2 0.0472	0.25 0.0098	5.5 0.2165	3	DF-500609	CCW	0.44	2.94	Integral Plastic
	10 0.3937	8 0.3150	1.2 0.0472	0.25 0.0098	5.5 0.2165	3	DF-500610	CW	0.44	2.94	Integral Plastic
	12 0.4724	11 0.4331	1.5 0.0591	0.25 0.0098	8.5 0.3346	5	FCP-6	CCW	0.10	2.94	Integral Plastic
	12 0.4724	11 0.4331	1.5 0.0591	0.25 0.0098	8.5 0.3346	5	FCPC-6	CW	0.10	2.94	Integral Plastic
	12 0.4724	11 0.4331	1.5 0.0591	0.25 0.0098	8.5 0.3346	5	FCP-6H	CCW	0.90	2.94	Integral Plastic
	12 0.4724	11 0.4331	1.5 0.0591	0.25 0.0098	8.5 0.3346	5	FCPC-6H	CW	0.90	2.94	Integral Plastic
8 0.3150	12 0.4724	8 0.3150	1.2 0.0472	0.25 0.0098	5.5 0.2165	9	DF-500808	CCW	0.50	2.94	Integral Plastic
	12 0.4724	8 0.3150	1.2 0.0472	0.25 0.0098	5.5 0.2165	9	DF-500809	CW	0.50	2.94	Integral Plastic
	12 0.4724	12 0.4724	1.2 0.0472	0.25 0.0098	9.5 0.3740	9	FCP-8	CCW	0.21	2.94	Integral Plastic
	12 0.4724	12 0.4724	1.2 0.0472	0.25 0.0098	9.5 0.3740	9	FCPC-8	CW	0.21	2.94	Integral Plastic
	12 0.4724	12 0.4724	1.2 0.0472	0.25 0.0098	9.5 0.3740	9	FCP-8H	CCW	1.67	2.94	Integral Plastic
	12 0.4724	12 0.4724	1.2 0.0472	0.25 0.0098	9.5 0.3740	9	FCPC-8H	CW	1.67	2.94	Integral Plastic
	12 0.4724	12 0.4724	1.2 0.0472	0.25 0.0098	9.5 0.3740	9	DF-500804	CCW	1.67	2.94	Integral Plastic
10 0.3937	14 0.5512	12 0.4724	1.2 0.0472	0.25 0.0098	9.5 0.3740	5	FCP-10	CCW	0.28	3.92	Integral Plastic
	14 0.5512	12 0.4724	1.2 0.0472	0.25 0.0098	9.5 0.3740	5	FCPC-10	CW	0.28	3.92	Integral Plastic
	14 0.5512	12 0.4724	1.2 0.0472	0.25 0.0098	9.5 0.3740	5	FCP-10H	CCW	2.26	3.92	Integral Plastic
	14 0.5512	12 0.4724	1.2 0.0472	0.25 0.0098	9.5 0.3740	5	FCPC-10H	CW	2.26	3.92	Integral Plastic

⁽¹⁾ Locking direction = Direction clutch must be rotated relative to shaft for clutch to lock as seen from staped end.



NOTES

HEAVY-DUTY NEEDLE ROLLER BEARINGS

Overview: Heavy-duty needle roller bearings consist of a machined and ground channel-shaped outer ring with a complement of needle rollers, and a cage. The high-strength cage retains and guides the rollers. An optional lubrication groove and hole in the outer ring facilitates re-lubrication. These bearings can be used with or without a machined and ground inner ring, depending on the suitability of the shaft as a raceway surface.

- **Sizes:** 5 mm – 335 mm (0.1969 in – 13.1890 in) bore.
- **Markets:** Gear pumps, sheaves, automotive transmissions and two-cycle engines.
- **Features:** Thick outer ring provides maximum load capacity and shock resistance with a relatively small radial cross section.
- **Benefits:** Optimum speed and lubrication-retention capability.

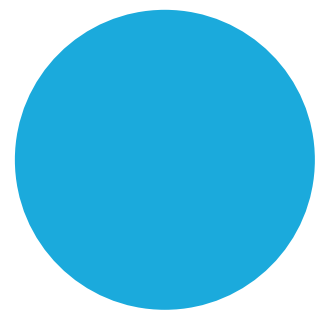
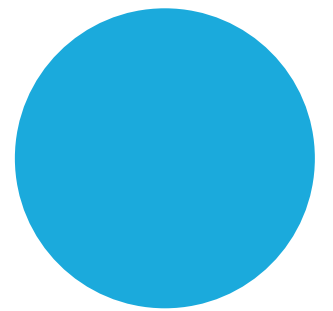

Needle Roller Bearings with Inner Rings – Metric Nominal Dimensions

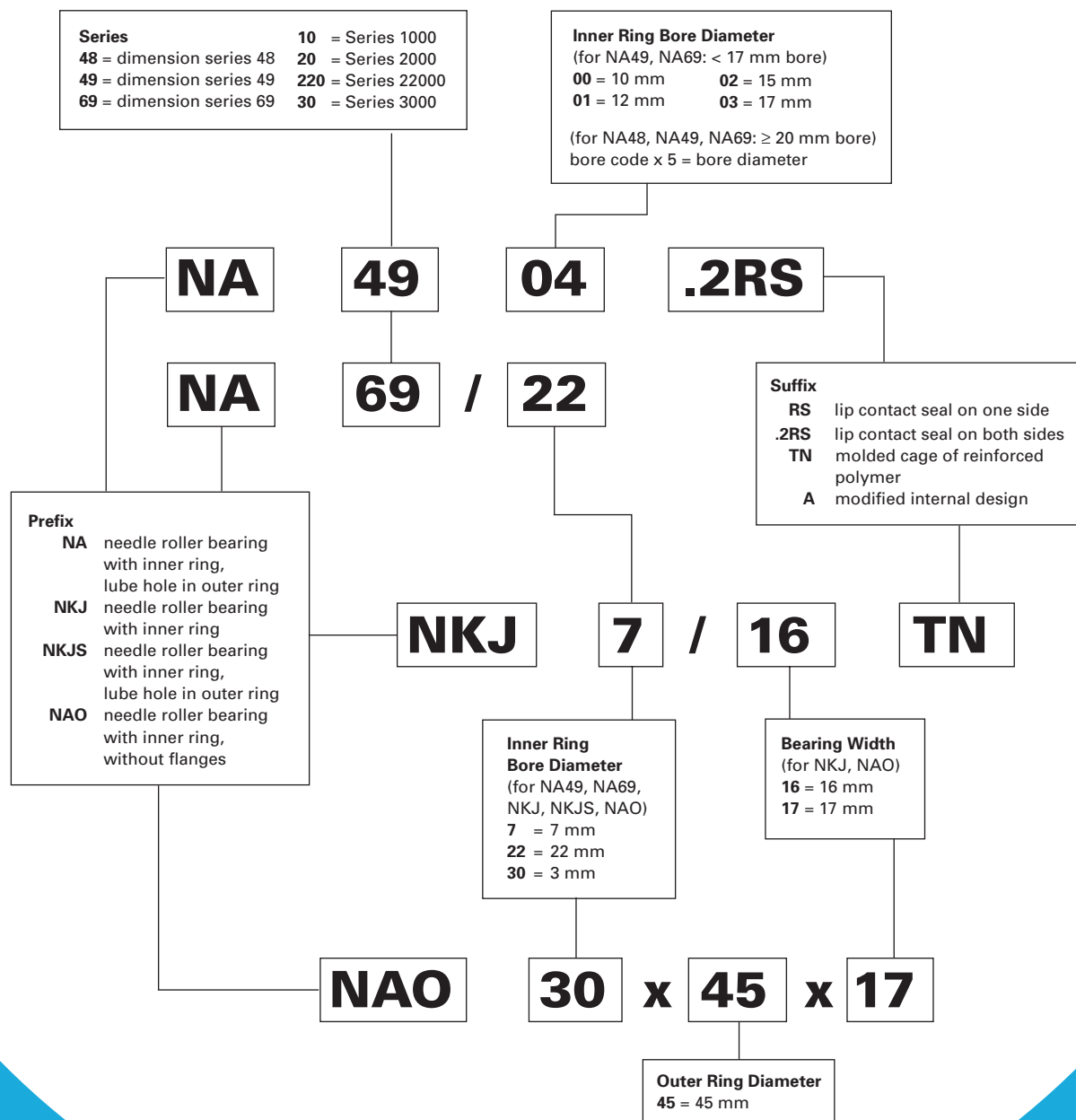

Needle Roller Bearings without Inner Rings – Metric Nominal Dimensions

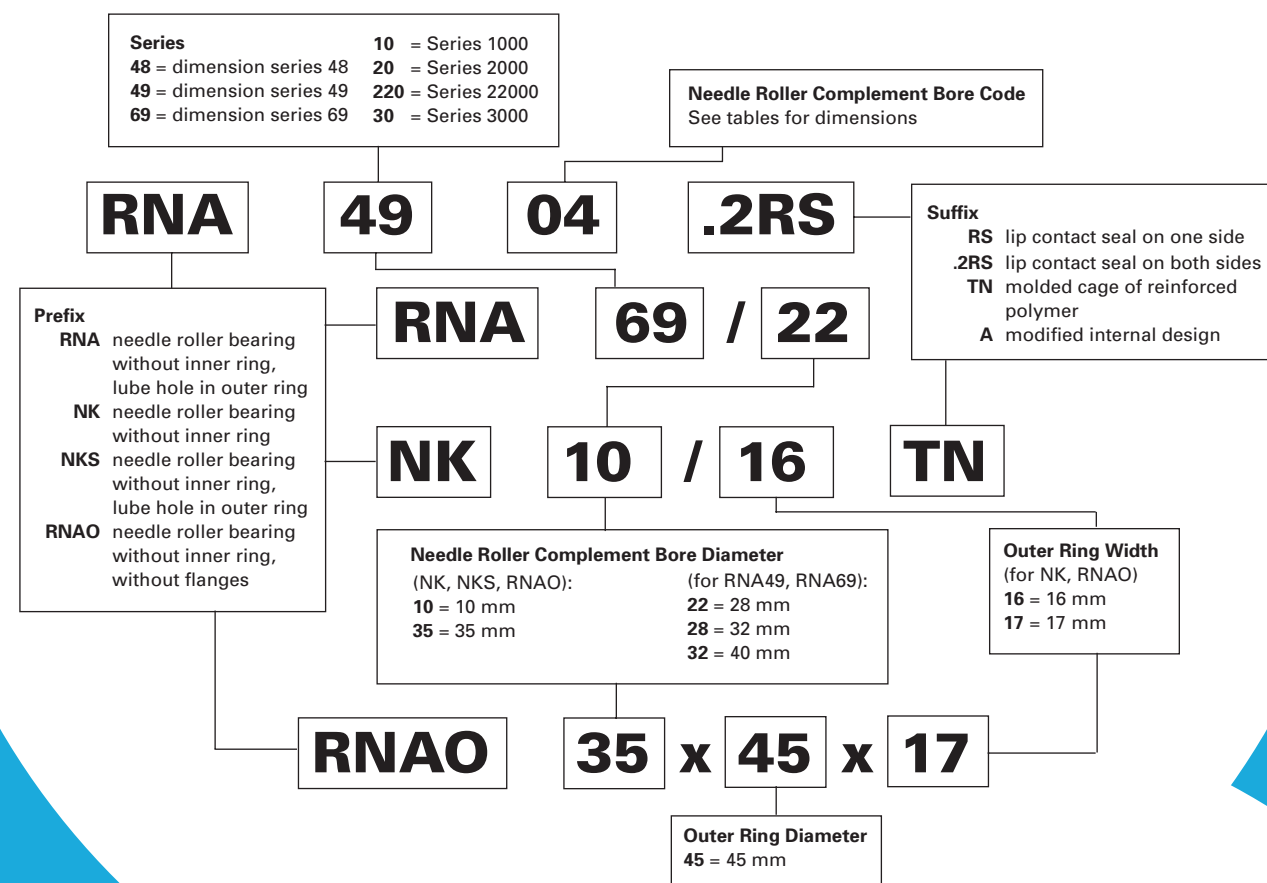

Inner Rings for Needle Roller Bearings – Metric Nominal Dimensions

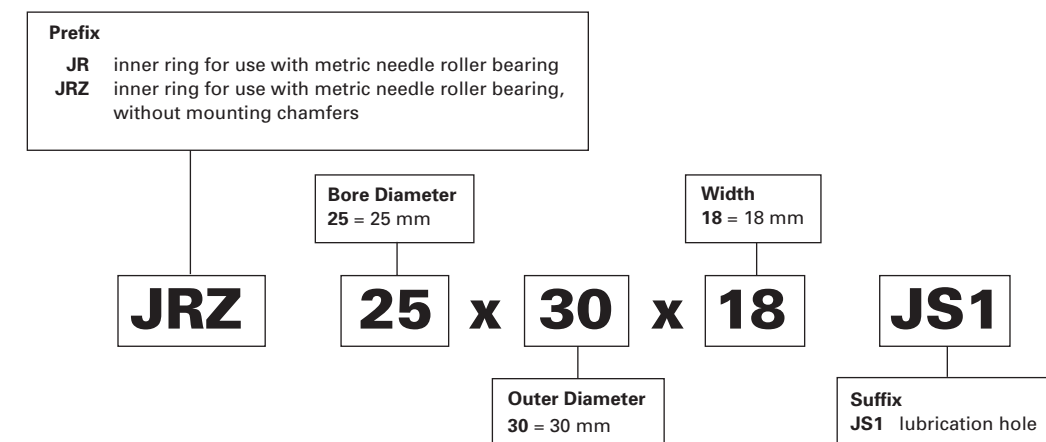

Needle Roller Bearings – Inch Nominal Dimensions

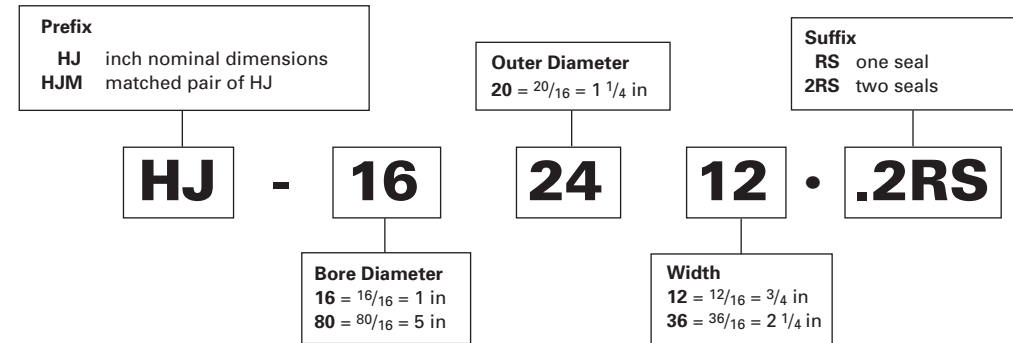

Inner Rings (six-digit number) – Inch Nominal Dimensions

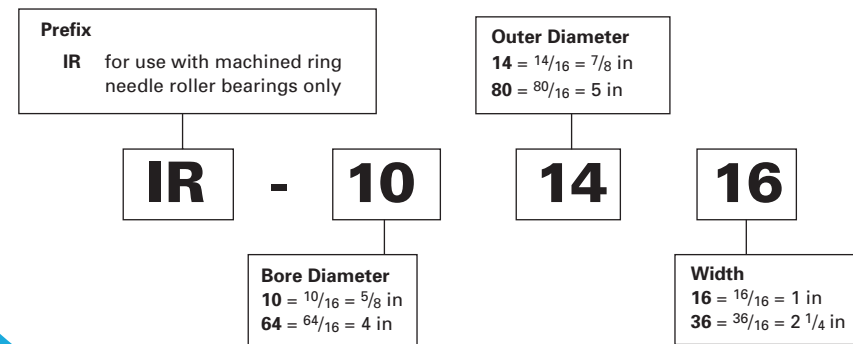

Cylindrical Roller Radial Bearings - Metric Nominal Dimensions

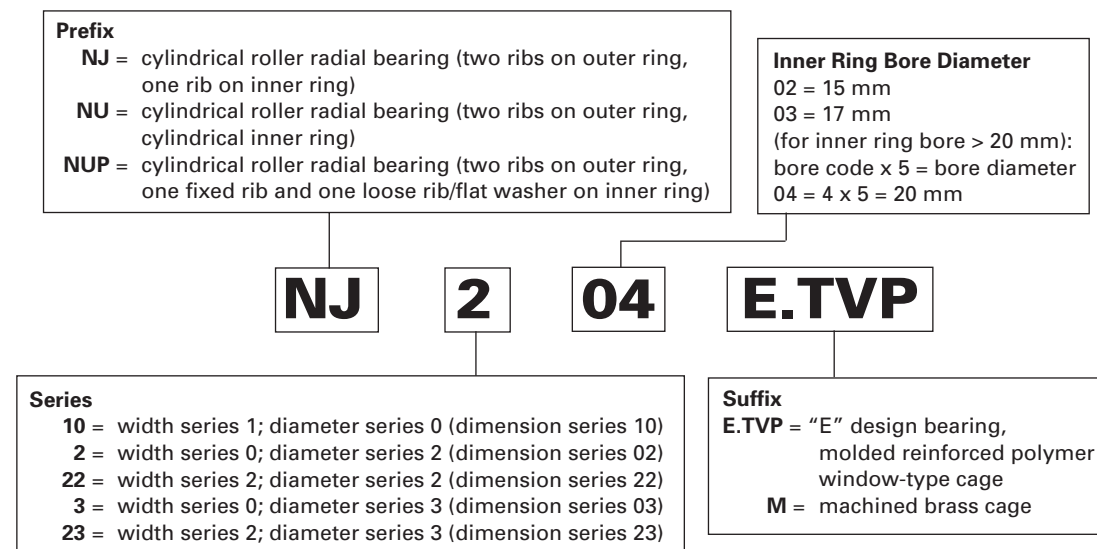

Heavy-Duty Needle Roller Bearings

Page

NEEDLE ROLLER BEARINGS, METRIC SERIES

Introduction B-148

Needle Roller Bearings with Inner Rings B-155

Needle Roller Bearings without Inner Rings B-161

Sealed Needle Roller Bearings with Inner Rings B-168

Sealed Needle Roller Bearings without Inner Rings B-169

Needle Roller Bearings without Flanges
 with Inner Rings B-170

Needle Roller Bearings without Flanges
 without Inner Rings B-173

Needle Roller Bearings Full Complement
 without Inner Rings B-176

Needle Roller Bearings Full Complement
 with Inner Rings B-180

SINGLE ROW RADIAL BEARINGS, METRIC SERIES

Introduction B-183

Dimensional Accuracy B-184

Mounting Dimensions B-184

Load Ratings B-186

Cylindrical Roller Radial Bearings B-188

NEEDLE ROLLER BEARINGS, INCH SERIES

Introduction B-191

Dimensional Accuracy, Bearings – HJ Series B-192

Dimensional Accuracy, Inner Rings – IR Series B-193

HJ Type B-194

Sealed Heavy-Duty Needle Roller Bearings B-198

Inner Rings B-200



NEEDLE ROLLER BEARINGS

METRIC SERIES

When applications involve very heavy dynamic, static or even shock load conditions, the needle roller bearing may be found to give best results.

REFERENCE STANDARDS ARE:

- ISO 1206 – needle roller bearings – light and medium series – dimensions and tolerances.
- DIN 617 – rolling bearings – needle roller bearings with cage – dimension Series 48 and 49.

TYPES OF METRIC SERIES NEEDLE ROLLER BEARINGS

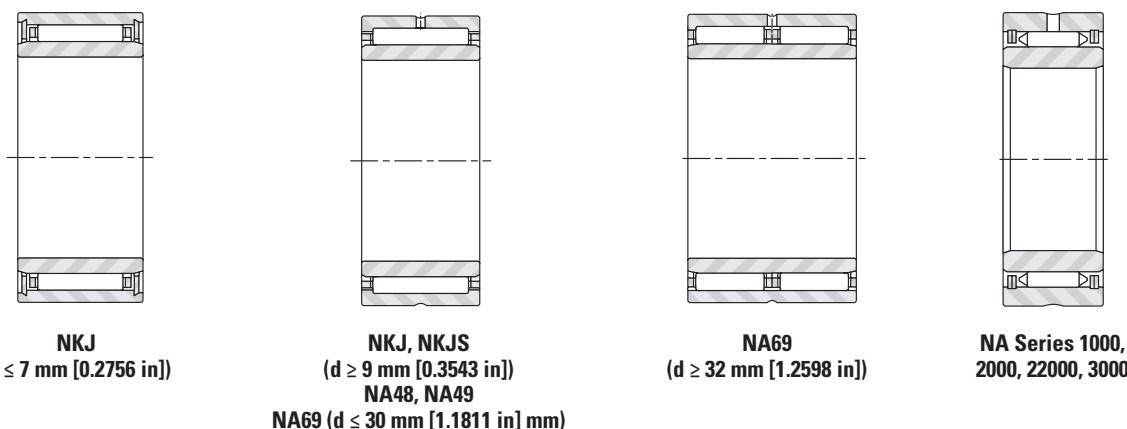

Fig. B-36. Needle roller bearings with inner rings

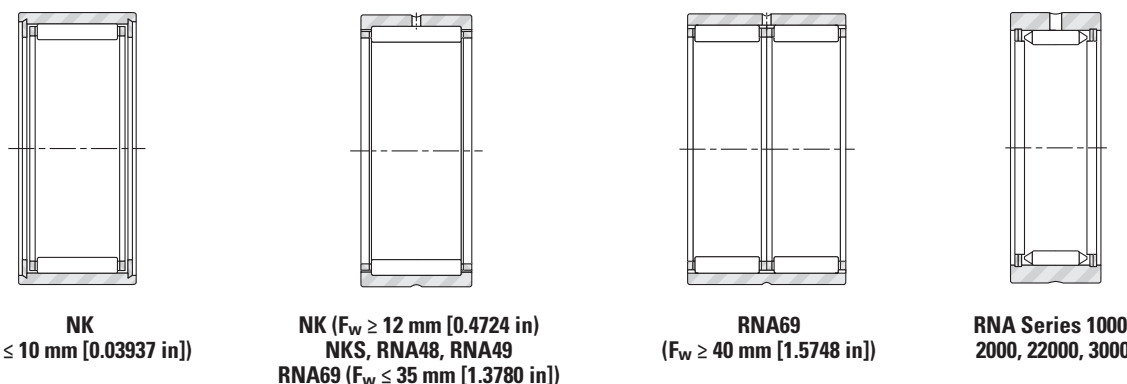

Fig. B-37. Needle roller bearings without inner rings

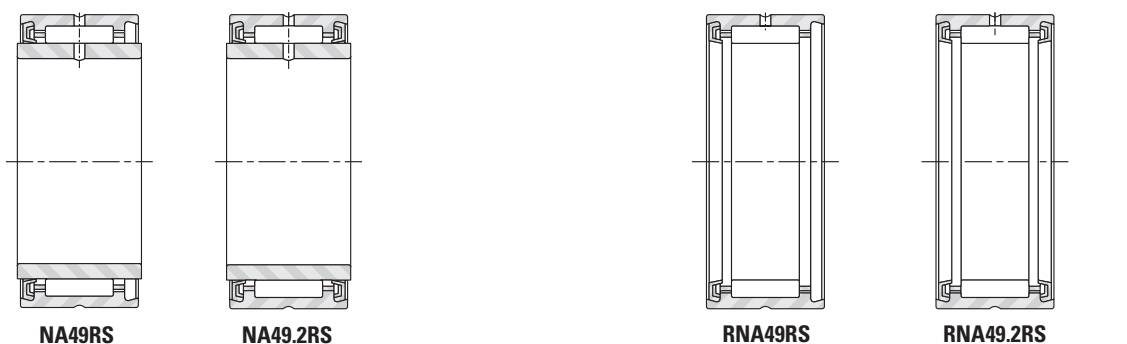

Fig. B-38. Sealed needle roller bearings with inner rings

Fig. B-39. Sealed needle roller bearings without inner rings



Fig. B-40. Needle roller bearings without flanges, with inner rings

Fig. B-41. Needle roller bearings without flanges, without inner rings

Suffixes	
RS	one seal
.2RS	two seals
TN	molded cage of engineered, reinforced polymer

CONSTRUCTION

The basic constructions of metric series needle roller bearings are:

- With integral end flanges on the one-piece, channel-shaped outer rings ($F_w \geq 12.000$ mm[0.4724 in]).
- With inserted-end washers to provide axial retention of the needle roller and cage assemblies ($F_w \leq 10.000$ mm 0.3937 in).
- Without flanges where separate end washers or housing shoulders are required to provide axial retention of the needle roller and cage assemblies.
- Full, outer ring piloted complement of needle rollers (with or without inner ring).

METRIC SERIES NEEDLE ROLLER BEARINGS WITH INNER RINGS

When it is impractical to finish the shaft to meet the desired raceway design requirements, an inner ring may be used. Standard needle roller bearings are available with inner rings (such as the NA Series) to form complete bearings. Bearings furnished with inner rings meet the quality requirements in accordance with ISO standards.

- For inner- and outer-ring tolerances, the metric series bearings follow the normal tolerance class in ISO Standard 492 covering radial bearings. Bearings to more precise tolerance classes, P6 and P5, may be obtained upon request.
- The metric series bearings may be obtained with radial internal clearance in accordance with ISO Standard 5753, also specified for cylindrical roller bearings. Mostly, they follow the normal (C0) radial clearance group, although bearings to clearance groups C2, C3 and C4 may be made available on request.
- Inner ring and outer ring chamfer dimensions meet the requirements of ISO Standard 582.

METRIC SERIES NEEDLE ROLLER BEARINGS WITHOUT INNER RINGS

Whenever the shaft can be used as the inner raceway, needle roller bearings without inner rings provide advantages of economy and close control of radial internal clearance in operation. Tolerance class F6 is the normal specification for the metric series needle roller complement bore diameter of an unmounted bearing, as shown in Table B-16 and Table B-17 on page B-150. In the case of needle roller bearings of series RNAO, without flanges and without inner rings, the outer rings and needle roller and cage assemblies are not interchangeable.

Table B-16. Metric series caged needle roller complement bore diameter for bearings without inner rings

F_w		ΔF_w min	
>	\leq	Max.	Min.
mm in	mm in	mm in	mm in
3.000 0.1181	6.000 0.2362	+0.018 +0.0007	+0.010 +0.0004
6.000 0.2362	10.000 0.3937	+0.022 +0.0009	+0.013 +0.0005
10.000 0.3937	18.000 0.7087	+0.027 +0.0011	+0.016 +0.0006
18.000 0.7087	30.000 1.1811	+0.033 +0.0013	+0.020 +0.0008
30.000 1.1811	50.000 1.9685	+0.041 +0.0016	+0.025 +0.0010
50.000 1.9685	80.000 3.1496	+0.049 +0.0019	+0.030 +0.0012
80.000 3.1496	120.000 4.7244	+0.058 +0.0023	+0.036 +0.0014
120.000 4.7244	180.000 7.0866	+0.068 +0.0027	+0.043 +0.0017
180.000 7.0866	250.000 9.8425	+0.079 +0.0031	+0.050 +0.0020
250.000 9.8425	315.000 12.4016	+0.088 +0.0035	+0.056 +0.0022
315.000 12.4016	400.000 15.7480	+0.098 +0.0039	+0.062 +0.0024



Table B-17. Full complement metric needle roller complement bore diameter for bearings without inner rings

F _w		ΔF _w min	
>	≤	Max.	Min.
mm in	mm in	mm in	mm in
5.000 0.1969	15.000 0.5906	+0.040 +0.0016	+0.020 +0.0008
15.000 0.5906	25.000 0.9843	+0.043 +0.0017	+0.020 +0.0008
25.000 0.9843	30.000 1.1811	+0.048 +0.0019	+0.025 +0.0010
30.000 1.1811	35.000 1.3780	+0.053 +0.0021	+0.030 +0.0012
35.000 1.3780	60.000 2.3622	+0.058 +0.0023	+0.035 +0.0014
60.000 2.3622	80.000 3.1496	+0.073 +0.0029	+0.045 +0.0018
80.000 3.1496	115.000 4.5276	+0.078 +0.0031	+0.050 +0.0020
115.000 4.5276	180.000 7.0866	+0.088 +0.0035	+0.060 +0.0024
180.000 7.0866	220.000 8.6614	+0.103 +0.0041	+0.070 +0.0028
220.000 8.6614	270.000 10.6299	+0.113 +0.0044	+0.080 +0.0031
270.000 10.6299	350.000 13.7795	+0.128 +0.0050	+0.090 +0.0035

METRIC SERIES NEEDLE ROLLER BEARINGS WITH INTEGRAL FLANGES

The needle roller bearing has a one-piece, channel-shaped outer ring of bearing-quality steel heat treated to yield maximum load rating. The integral end flanges provide axial location for the needle rollers. The bores of the end flanges serve as piloting surfaces for the cage.

A steel cage provides inward retention for the needle rollers, and the design assures roller stability and minimizes friction between the cage and the needle rollers. The cage has maximum strength consistent with the inherent high-load ratings of needle roller bearings.

Needle roller bearings of series NKJ, NKJS, NA48 and NA49 contain one needle roller and cage assembly. Bearings of series NA69, with bearing bores of 32.000 mm (1.2598 in) and above, have two needle roller and cage assemblies.

The outer ring has a lubricating groove and a lubricating hole for more convenient lubrication of the bearing. However, the smaller bearings of series NKJ and NK do not have a lubricating groove or a lubricating hole (F_w < 10 mm [0.3937 in]).

METRIC SERIES NEEDLE ROLLER BEARINGS WITH INSERTED END WASHERS

Some metric series needle roller bearings have inserted end washers to provide axial retention of the needle roller and cage assembly. The radial needle roller and cage assemblies, consistent with other designs, provide inward and outward retention for the needle rollers.

METRIC SERIES NEEDLE ROLLER BEARINGS WITHOUT FLANGES

The radial needle roller and cage assembly, used in the metric series needle roller bearings without flanges, is slightly narrower than the inner and outer rings to ensure unobstructed operation. Separate end washers are required to provide axial retention of the radial needle roller and cage assembly. Wide needle roller bearings, using two needle roller and cage assemblies, have a lubricating groove and one lubricating hole in the outer ring to facilitate re-lubrication of the bearing. Narrow needle roller bearings do not have a lubricating groove or a lubricating hole in the outer ring.

SEALED METRIC SERIES NEEDLE ROLLER BEARINGS OF DIMENSION SERIES 49

Needle roller bearings of Series 49 are available with one or two integral lip-contact seals, as listed on page B-168. One seal is designated by suffix letters RS. Two seals are designated by .2RS. When combining sealed metric series needle roller bearings with inner rings, it is suggested to use inner rings, shown on pages B-65 and B-368, with designation JRZ because they are wider than the outer rings to ensure positive seal contact.

These seals limit the bearing operating temperature between -30° C and 110° C (-25° F and 225° F). If the operating temperature must be outside the above range or if the seals are exposed to unusual fluids, external seals using suitable seal materials or other solutions should be investigated. Sealed bearings are normally packed with a high quality lithium soap-based grease suitable up to 120° C (248° F) for short periods of operation.

The speed rating specified for sealed bearings listed in the bearing tables is based on operating conditions determined by testing. Optimum performance may be expected providing the bearing is properly installed with appropriate internal clearances and subjected to a load of low magnitude. Care should be taken that overheating will not occur, thus preventing breakdown of the grease and eventual bearing failure.

METRIC SERIES FULL COMPLEMENT NEEDLE ROLLER BEARINGS

Series NA and RNA 1000, 2000, 22000 and 3000 are available with possible options of extra wide and/or crowned inner ring raceways. Consult your representative for application details.

BEARING MOUNTING

MOUNTING DIMENSIONS

It is suggested that needle roller bearings are mounted in their housings with a clearance fit, if the load is stationary relative to the housing, or with a tight transition fit, if the load rotates relative to the housing. Table B-18 lists the suggested tolerances for the housing bore and the shaft raceway for metric series bearings without inner rings. Table B-19 lists the suggested shaft tolerances for the above two mounting conditions when the metric series bearings are used with inner rings. The suggested housing bore tolerances for metric series bearings with inner rings is the same as the housing bore tolerance listed in Table B-18 for metric series bearings without inner rings. Other quality requirements for shafts and housings are given in the engineering section.

Other mounting dimensions may be required for special operating conditions such as:

1. Extremely heavy radial loads.
2. Shock loads.
3. Temperature gradient across bearing.
4. Housing material with heat expansion coefficient different than that of the bearing.
5. Oscillating motion applications.

Table B-18. Mounting tolerances for metric series bearings without inner ring

Rotation conditions	Nominal housing bore diameter D	ISO tolerance zone for housing		Nominal shaft diameter F	ISO tolerance zone for shaft	
		caged	full		caged	full
Load stationary relative to housing	all diameters	H7 (J7)	J6	all diameters	h6	h5
General work with larger clearance	all diameters	K7	—	all diameters	g6	—
Load rotates relative to housing	all diameters	N7	M6	all diameters	f6	g5

Care should be taken that the selected bearing internal clearance is appropriate for the operating conditions.

Table B-19. Shaft tolerances for metric series bearings with inner rings (use housing tolerance shown in table above)

Rotation conditions	Nominal shaft diameter, d		ISO tolerance zone for shaft	
	mm in	mm in	caged	full
Load rotates relative to housing	all diameters		g6	H5 (h6)
Load stationary relative to housing	>	≤		
	40.000 1.5748		k6	k5
	40.000 1.5748	100.000 3.9370	m6	m5
	100.000 3.9370	140.000 5.5118	m6	m5
	140.000 5.5118		n6	n6

Care should be taken that the selected bearing internal clearance is appropriate for the operating conditions.

Regardless of the fit of the bearing outer ring in the housing, the outer ring should be axially located by housing shoulders or other positive means. The bearing rings should closely fit against the shaft and housing shoulders and must not contact the fillet radius. The maximum shaft or housing fillet r_{a max} should be no greater than the minimum bearing chamfer r_{s min}, as shown in Table B-20 on page B-152.

In order to permit mounting and dismounting of the shaft, the maximum diameter D₁ in Table B-21 on page B-152 must not be exceeded. F_w is shown in the bearing tables.

Needle roller bearings without flanges of series RNA0 and NAO must have the radial needle roller and cage assembly properly end-guided by shoulders, as shown in Table B-22(1) on page B-153 and Table B-22(2) on page B-154, or other suitable means, such as spring steel washers (SNSH) shown on page B-385. These end-guiding surfaces should be hardened and precision turned, or ground to minimize wear, and should properly fit against the outer rings and the inner rings to provide the desired end clearance for the needle roller and cage assembly.

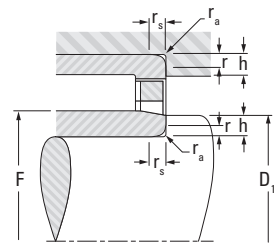

Fillet

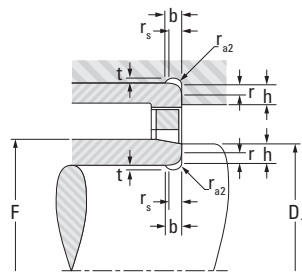

Undercut

Table B-20. Fillets, undercuts, and shoulder heights for metric series bearings

$r_s^{(1)}$	r_a	t	r_{a2}	b	h
Min.	Max.		Min.		Min.
mm in	mm in	mm in	mm in	mm in	mm in
0.15 0.0059	0.15 0.0059				0.6 0.0236
0.3 0.0118	0.3 0.0118				1 0.0394
0.6 0.0236	0.6 0.0236				2 0.0787
1 0.0394	1 0.0394	0.2 0.0079	1.3 0.0512	2 0.0787	2.5 0.0984
1.1 0.0433	1 0.0394	0.3 0.0118	2 0.0787	3 0.1181	3.25 0.1280
1.5 0.0591	1.5 0.0591	0.4 0.0158	2 0.0787	3.2 0.1260	4 0.1575
2 0.0787	2 0.0787	0.5 0.0197	2.5 0.0984	4 0.1575	5 0.1969
2.1 0.0827	2.1 0.0827	0.5 0.0197	3 0.1181	4.7 0.1850	5.5 0.2165
3 0.1181	2.5 0.0984	0.5 0.0197	3.5 0.1378	5.3 0.2087	6 0.2362

⁽¹⁾ r_s : Bearing component corner rounding.

Table B-21. Shoulder diameter D_{1max} for metric series bearings

		mm in	mm in	mm in	mm in	mm in
Needle roller complement bore diameter F_w	>		20.000 0.7874	55.000 2.1653	100.000 3.9370	250.000 9.8425
	≤	20.000 0.7874	55.000 2.1653	100.000 3.9370	250.000 9.8425	
Diameter	D_{1max}	$F_w - 0.3$	$F_w - 0.5$	$F_w - 0.7$	$F_w - 1.0$	$F_w - 1.5$

LOAD RATING FACTORS

DYNAMIC LOADS

Needle roller bearings can accommodate only radial loads.

$$P = F_r \quad (\text{kN})$$

P = The maximum dynamic radial load that may be applied to a needle roller bearing based on the dynamic load rating, C , given in the bearing tables. This load should be $\leq C/3$.

STATIC LOADS

Needle roller bearings can accommodate only radial loads.

$$P_0 = F_r \quad (\text{kN})$$

MOUNTING IN SETS

Radial needle roller and cage assemblies that are mounted side by side must have needle rollers of the same group limits to ensure uniform load distribution.

RNAO Series

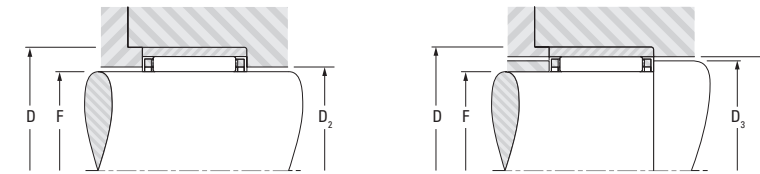

Fig. B-42. Guidance in the housing (left) and on the shaft (right)

Table B-22(1). Mounting dimensions for metric series needle roller bearings without flanges

Fx D	D_3	D_2	D_5	Bearing series RNAO			
				Max.		Min.	
mm in	mm in	mm in	mm in	mm in	mm in	mm in	mm in
10x17 0.3937x0.6693	12.7 0.5000	10.3 0.4055	13.3 0.5236				
12x19 0.4724x0.7480	14.7 0.5787	12.3 0.4843	15.3 0.6024				
14x22 0.5512x0.8661	17.6 0.6929	14.4 0.5669	18.3 0.7205				
15x23 0.5906x0.9055	18.6 0.7323	15.4 0.6063	19.3 0.7598				
16x24 0.6299x0.9499	19.6 0.7717	16.4 0.6457	20.3 0.7992				
17x25 0.6693x0.9843	20.6 0.8110	17.4 0.6850	21.3 0.8386				
18x26 0.7087x1.0236	21.6 0.8504	18.4 0.7244	22.3 0.8780				
18x30 0.7087x1.1811	23.6 0.9291	18.6 0.7323	24.5 0.9646				
20x28 0.7874x1.1024	23.6 0.9291	20.4 0.8032	24.3 0.9567				
20x32 0.7874x1.2598	25.6 1.0079	20.6 0.8110	26.5 1.0433				
22x30 0.8661x1.1811	25.6 1.0079	22.4 0.8819	26.3 0.9291				
22x35 0.8661x1.3780	28.4 1.1181	22.8 0.8976	29.5 1.1614				
25x35 0.9843x1.3780	29.4 1.1575	25.6 1.0079	30.5 1.2008				
25x37 0.9843x1.4567	31.4 1.2362	25.8 1.0158	32.5 1.2795				
28x40 1.1024x1.5748	34.4 1.3543	28.8 1.1339	35.5 1.3976				
30x40 1.1811x1.5748	34.4 1.3543	30.6 1.2047	35.5 1.3976				
30x42 1.1811x1.6535	36.4 1.4331	30.8 1.2126	37.5 1.4764				
35x45 1.3780x1.7717	39.4 1.5512	35.6 1.4016	40.5 1.5945				
35x47 1.3780x1.8504	41.4 1.6299	35.8 1.4096	42.5 1.6732				
40x50 1.5748x1.9685	44.4 1.7480	40.6 1.5984	45.5 1.7913				
40x55 1.5748x2.1654	47.2 1.8582	41 1.6142	48.5 1.9095				
45x55 1.7717x2.1654	49.4 1.9449	45.6 1.7953	50.5 1.9882				
45x62 1.7717x2.4409	52.2 2.0551	46 1.8110	53.5 2.1063				
50x62 1.9685x2.4409	54.4 2.1417	50.6 1.9921	55.8 2.1969				
50x65 1.9685x2.5591	57.2 2.2520	51 2.0079	58.8 2.3032				
55x68 2.1654x2.6772	59.4 2.3386	55.6 2.1890	60.8 2.3937				
55x72 2.1654x2.8347	62.2 2.4488	56 2.2047	63.8 2.5118				
60x78 2.3622x3.0709	67.2 2.6457	61 2.4016	68.8 2.7087				
65x85 2.5591x3.3465	72.2 2.8425	66 2.5984	73.8 2.9055				
70x90 2.7559x3.5433	77.2 3.0394	71 2.7953	78.8 3.1024				
75x95 2.9528x3.7402	82.2 3.2362	76 2.9921	84 3.3071				
80x100 3.1496x3.9370	87.2 3.4331	81 3.1890	89 3.5039				
85x105 3.3465x4.1339	92.2 3.6299	86 3.3858	94 3.7008				
90x110 3.5433x4.3307	97.2 3.8268	91 3.5827	99 3.8976				
95x115 3.7402x4.5276	102.2 4.0236	96 3.7795	104 4.0945				
100x120 3.9370x4.7244	107.2 4.2205	101 3.9764	109 4.2913				

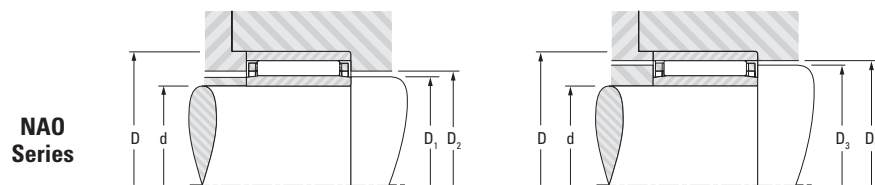

Fig. B-43. Guidance in the housing (left) and on the shaft (right)

Table B-22(2). Mounting dimensions for metric series needle roller bearings without flanges

dxD Dimensions	D ₁	D ₂	D ₃	D ₅	dxD Dimensions	D ₁	D ₂	D ₃	D ₅
	Bearing series NAO					Bearing series NAO			
	Max.	Min.	Max.	Min.		Max.	Min.	Max.	Min.
6x17 0.2362x0.6693	9.7	10.3	12.7	13.3	35x50 1.3780x1.9685	39.5	40.6	44.4	45.5
8x19 0.3150x0.7480	11.7	12.3	14.7	15.3	35x55 1.3780x2.1654	39.5	41	47.2	48.5
10x22 0.3937x0.8661	13.7	14.4	17.6	18.3	40x55 1.5748x2.1654	44.5	45.6	49.4	50.5
10x26 0.3937x1.0236	13.7	14.6	19.6	20.3	40x62 1.5748x2.4409	44.5	46	52.2	53.5
12x24 0.4724x0.9449	15.7	16.4	19.6	20.3	45x62 1.7717x2.4409	49.5	50.6	54.4	55.8
12x28 0.4724x1.1024	15.7	16.6	21.6	22.3	45x72 1.7717x2.8347	54.5	56	62.2	63.8
15x28 0.5906x1.1024	19.5	20.4	23.6	24.3	50x68 1.9685x2.6772	54.5	55.6	59.4	60.8
15x32 0.5906x1.2598	19.5	20.6	25.6	26.5	50x78 1.9685x3.0709	59.3	61	67.2	68.8
17x30 0.6693x1.1811	21.5	22.4	25.6	26.3	55x85 2.1654x3.3465	64.3	66	72.2	73.8
17x35 0.6693x1.3780	21.5	22.8	28.4	29.5	60x90 2.3622x3.5433	69.3	71	77.2	78.8
20x35 0.7874x1.3780	24.5	25.6	29.4	30.5	65x95 2.5591x3.7402	74.3	76	82.2	84
20x37 0.7874x1.4567	24.5	25.8	31.4	32.5	70x100 2.7559x3.9370	79.3	81	87.2	89
25x40 0.9843x1.5748	29.5	30.6	34.4	35.5	75x105 2.9528x4.1339	84.3	86	92.2	94
25x42 0.9843x1.6535	29.5	30.8	36.4	37.5	80x110 3.1496x4.3307	89.3	91	97.2	99
30x45 1.1811x1.7717	34.5	35.6	39.4	40.5	85x115 3.3465x4.5276	94.3	96	102.2	104
30x47 1.1811x1.8504	34.5	35.8	41.4	42.5	90x120 3.5433x4.7244	99.3	101	107.2	109

NEEDLE ROLLER BEARINGS WITH INNER RINGS

METRIC SERIES

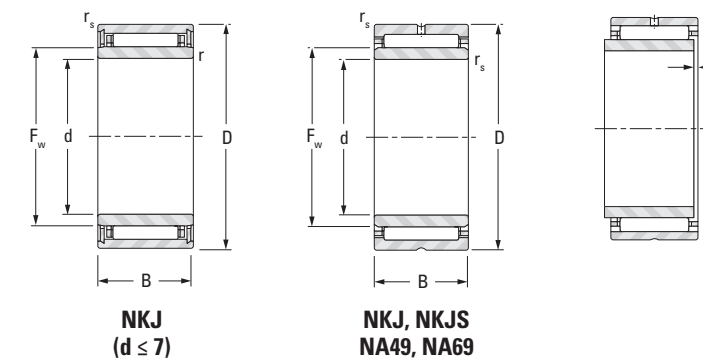

NKJ (d ≤ 7)

NKJ, NKJS NA49, NA69

Shaft Dia.	d	D	B	F _w	r _s min	s ⁽¹⁾	Bearing Designation	Load Ratings		Speed Rating		C ₉	Approx. Wt.
								Dynamic	Static	Oil	Grease		
								C	C ₀	min ⁻¹			
5 0.1969	5 0.1969	15 0.5906	12 0.472	8 0.3150	0.3 0.012	1.5 0.059	NKJ5/12	4.57 1030	4.89 1100	41000	26000	0.0148	0.014 0.031
	5 0.1969	15 0.5906	16 0.630	8 0.3150	0.3 0.012	1.5 0.059	NKJ5/16	5.22 1170	5.78 1300	41000	26000	0.0154	0.017 0.037
	6 0.2362	16 0.6299	12 0.472	9 0.3543	0.3 0.012	1.5 0.059	NKJ6/12	4.27 960	4.60 1030	40000	26000	0.0153	0.015 0.033
	6 0.2362	16 0.6299	16 0.630	9 0.3543	0.3 0.012	1.5 0.059	NKJ6/16	5.57 1250	6.47 1450	40000	26000	0.0167	0.019 0.042
	7 0.2756	17 0.6693	12 0.472	10 0.3937	0.3 0.012	1.5 0.059	NKJ7/12	5.40 1210	6.43 1450	39000	25000	0.0174	0.017 0.037
	7 0.2756	17 0.6693	16 0.630	10 0.3937	0.3 0.012	1.5 0.059	NKJ7/16TN	5.30 1190	6.27 1410	39000	25000	0.0173	0.021 0.046
	9 0.3543	19 0.7480	12 0.472	12 0.4724	0.3 0.012	1.5 0.059	NKJ9/12	6.86 1540	7.60 1710	30000	19000	0.0189	0.018 0.040
	9 0.3543	19 0.7480	16 0.630	12 0.4724	0.3 0.012	1.5 0.059	NKJ9/16	6.78 1520	9.03 2030	30000	19000	0.0204	0.024 0.053
	10 0.3937	22 0.8661	13 0.512	14 0.5512	0.3 0.012	1.0 0.039	NA4900	9.39 2110	10.3 2320	24000	16000	0.0211	0.025 0.055
	10 0.3937	22 0.8661	16 0.630	14 0.5512	0.6 0.024	1.5 0.059	NKJ10/16	12.4 2790	14.8 3330	24000	16000	0.0231	0.032 0.071
	10 0.3937	22 0.8661	20 0.787	14 0.5512	0.3 0.012	1.5 0.059	NKJ10/20	14.7 3300	18.4 4140	24000	16000	0.0244	0.040 0.088
	12 0.4724	24 0.9449	13 0.512	16 0.6299	0.3 0.012	1.0 0.039	NA4901	10.5 2360	12.0 2700	28000	18000	0.0233	0.028 0.062
	12 0.4724	24 0.9449	16 0.630	16 0.6299	0.3 0.012	1.5 0.059	NKJ12/16	13.0 2920	16.2 3640	28000	18000	0.0250	0.036 0.079
	12 0.4724	24 0.9449	20 0.787	16 0.6299	0.3 0.012	1.5 0.059	NKJ12/20	15.4 3460	20.2 4540	28000	18000	0.0264	0.046 0.101
	12 0.4724	24 0.9449	22 0.866	16 0.6299	0.3 0.012	1.0 0.039	NA6901	16.1 3620	21.3 4790	28000	18000	0.0267	0.051 0.110
	15 0.5906	27 1.0630	16 0.630	19 0.7480	0.3 0.012	1.5 0.059	NKJ15/16	14.1 3170	19.0 4270	24000	15000	0.0279	0.042 0.093
	15 0.5906	27 1.0630	20 0.787	19 0.7480	0.3 0.012	1.5 0.059	NKJ15/20	16.8 3780	23.6 5310	24000	15000	0.0295	0.054 0.119
	15 0.5906	28 1.1024	13 0.512	20 0.7874	0.3 0.012	1.0 0.039	NA4902	11.8 2650	15.3 3440	22000	14000	0.0270	0.037 0.082
	15 0.5906	28 1.1024	23 0.906	20 0.7874	0.3 0.012	1.5 0.059	NA6902	18.4 4140	26.9 6050	22000	14000	0.0311	0.067 0.148
	17 0.6693	29 1.1417	16 0.630	21 0.8268	0.3 0.012	2.0 0.079	NKJ17/16	15.3 3440	21.6 4860	21000	14000	0.0301	0.047 0.104

⁽¹⁾ Max. axial displacement.

Continued on next page.



NEEDLE ROLLER BEARINGS WITH INNER RINGS – continued

METRIC SERIES

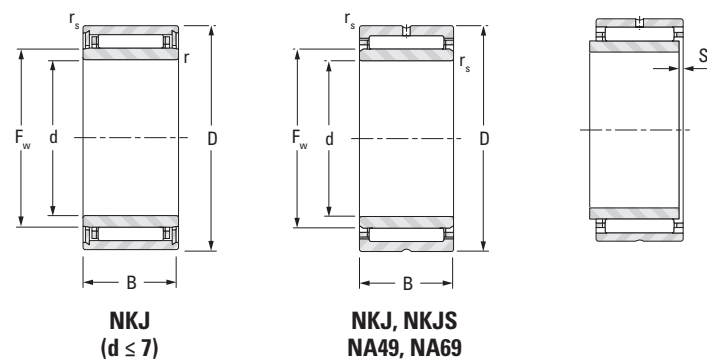

Shaft Dia.	d	D	B	F _w	r _s min	s ⁽¹⁾	Bearing Designation	Load Ratings		Speed Rating		C _g	Approx. Wt.
								Dynamic	Static	Oil	Grease		
								C	C ₀				
mm in	mm in	mm in	mm in	mm in	mm in	mm in		kN lbf	min ⁻¹	kg lbs			
17 0.6693	17 0.6693	29 1.1417	20 0.787	21 0.8268	0.3 0.012	1.5 0.059	NKJ17/20	18.1 4070	23.9 5370	21000	14000	0.0317	0.059 0.130
	17 0.6693	30 1.1811	13 0.512	22 0.8661	0.3 0.012	1.0 0.039	NA4903	12.2 2740	16.4 3690	20000	13000	0.0286	0.040 0.088
	17 0.6693	30 1.1811	23 0.906	22 0.8661	0.6 0.024	1.0 0.039	NA6903	19.8 4450	30.6 6880	20000	13000	0.0334	0.084 0.185
	17 0.6693	37 1.4567	20 0.787	24 0.9449	0.6 0.024	1.0 0.039	NKJS17	29.1 6540	32.8 7370	20000	13000	0.0325	0.108 0.238
20 0.7874	20 0.7874	32 1.2598	16 0.630	24 0.9449	0.3 0.012	1.5 0.059	NKJ20/16	16.2 3640	24.3 5460	18000	12000	0.0328	0.053 0.117
	20 0.7874	32 1.2598	20 0.787	24 0.9449	0.3 0.012	1.5 0.059	NKJ20/20	19.3 4340	30.3 6810	18000	12000	0.0346	0.067 0.148
	20 0.7874	37 1.4567	17 0.669	25 0.9843	0.3 0.012	1.5 0.059	NA4904	21.3 4790	25.5 5730	18000	12000	0.0318	0.084 0.185
	20 0.7874	37 1.4567	30 1.181	25 0.9843	0.3 0.012	1.5 0.059	NA6904	36.6 8230	51.0 11500	18000	12000	0.0378	0.133 0.293
	20 0.7874	42 1.6535	20 0.787	28 1.1024	0.6 0.024	1.0 0.039	NKJS20	30.3 6810	38.4 8630	16000	11000	0.0364	0.130 0.287
22 0.8661	22 0.8661	34 1.3386	16 0.630	26 1.0236	0.3 0.012	1.5 0.059	NKJ22/16	16.6 3730	25.7 5780	17000	11000	0.0344	0.058 0.128
	22 0.8661	34 1.3386	20 0.787	26 1.0236	0.3 0.012	2.0 0.079	NKJ22/20	19.7 4430	32.0 7190	17000	11000	0.0363	0.071 0.157
	22 0.8661	39 1.5354	17 0.669	28 1.1024	0.3 0.012	1.5 0.059	NA49/22	23.3 5240	29.6 6650	16000	10000	0.0346	0.089 0.196
	22 0.8661	39 1.5354	30 1.181	28 1.1024	0.3 0.012	1.0 0.039	NA69/22	30.6 6880	50.7 11400	16000	10000	0.0487	0.163 0.359
25 0.9843	25 0.9843	38 1.4961	20 0.787	29 1.1417	0.3 0.012	2.0 0.079	NKJ25/20	23.4 5260	36.4 8180	15000	9800	0.0383	0.086 0.190
	25 0.9843	38 1.4961	30 1.181	29 1.1417	0.3 0.012	2.0 0.079	NKJ25/30	29.8 6700	56.4 12700	15000	9800	0.0438	0.130 0.287
	25 0.9843	42 1.6535	17 0.669	30 1.1811	0.3 0.012	1.5 0.059	NA4905	24.3 5460	31.7 7130	15000	9700	0.0362	0.099 0.218
	25 0.9843	42 1.6535	30 1.181	30 1.1811	0.3 0.012	1.5 0.059	NA6905	39.7 8920	59.6 13400	15000	9700	0.0424	0.178 0.392
	25 0.9843	47 1.8504	22 0.866	32 1.2598	0.6 0.024	1.5 0.059	NKJS25	36.0 8090	36.2 8140	14000	9200	0.0398	0.174 0.384
28 1.1024	28 1.1024	42 1.6535	20 0.787	32 1.2598	0.3 0.012	2.0 0.079	NKJ28/20	24.8 5580	40.4 9080	14000	8800	0.0411	0.104 0.229
	28 1.1024	42 1.6535	30 1.181	32 1.2598	0.3 0.012	2.0 0.079	NKJ28/30	35.6 8000	64.3 14500	14000	8800	0.0461	0.156 0.344

⁽¹⁾ Max. axial displacement.

Continued on next page.

Shaft Dia.	d	D	B	F _w	r _s min	s ⁽¹⁾	Bearing Designation	Load Ratings		Speed Rating		C _g	Approx. Wt.
								Dynamic	Static	Oil	Grease		
								C	C ₀				
mm in	mm in	mm in	mm in	mm in	mm in	mm in		kN lbf	min ⁻¹	kg lbs			
28 1.1024	28 1.1024	45 1.7717	17 0.669	32 1.2598	0.3 0.012	1.5 0.059	NA49/28	25.1 5640	33.8 7600	14000	9000	0.0378	0.108 0.238
	28 1.1024	45 1.7717	30 1.181	32 1.2598	0.3 0.012	1.5 0.059	NA69/28	37.1 8340	55.4 12500	14000	9000	0.0434	0.190 0.419
30 1.1811	30 1.1811	45 1.7717	20 0.787	35 1.3780	0.3 0.012	1.5 0.059	NKJ30/20	26.1 5870	44.4 9980	12000	8000	0.0437	0.120 0.265
	30 1.1811	45 1.7717	30 1.181	35 1.3780	0.3 0.012	1.5 0.059	NKJ30/30	37.4 8410	70.6 15900	12000	8000	0.0491	0.179 0.395
	30 1.1811	47 1.8504	17 0.669	35 1.3780	0.3 0.012	1.5 0.059	NA4906	25.9 5820	36.0 8090	13000	8200	0.0399	0.114 0.251
	30 1.1811	47 1.8504	30 1.181	35 1.3780	0.3 0.012	1.0 0.039	NA6906	42.6 9580	68.2 15300	13000	8200	0.0467	0.205 0.452
	30 1.1811	52 2.0472	22 0.866	37 1.4567	0.6 0.024	1.5 0.059	NKJS30	39.0 8770	53.4 12000	12000	7900	0.0438	0.198 0.437
32 1.2598	32 1.2598	47 1.8504	20 0.787	37 1.4567	0.3 0.012	2.0 0.079	NKJ32/20	26.6 5980	46.4 10400	12000	7600	0.0453	0.127 0.280
	32 1.2598	47 1.8504	30 1.181	37 1.4567	0.3 0.012	1.5 0.059	NKJ32/30	38.2 8590	73.9 16600	12000	7600	0.0508	0.192 0.423
	32 1.2598	52 2.0472	20 0.787	40 1.5748	0.6 0.024	1.5 0.059	NA49/32	32.0 7190	49.3 11100	11000	7100	0.0457	0.169 0.373
	32 1.2598	52 2.0472	36 1.417	40 1.5748	0.6 0.024	1.0 0.039	NA69/32	48.6 10900	84.5 19000	11000	7100	0.0620	0.313 0.690
35 1.3780	35 1.3780	50 1.9685	20 0.787	40 1.5748	0.3 0.012	2.0 0.079	NKJ35/20	27.8 6250	50.4 11300	11000	7000	0.0479	0.135 0.298
	35 1.3780	50 1.9685	30 1.181	40 1.5748	0.3 0.012	1.5 0.059	NKJ35/30	40.0 8990	80.2 18000	11000	7000	0.0537	0.208 0.459
	35 1.3780	55 2.1654	20 0.787	42 1.6535	0.6 0.024	1.5 0.059	NA4907	32.8 7370	51.7 11600	10000	6700	0.0472	0.179 0.395
	35 1.3780	55 2.1654	36 1.417	42 1.6535	0.6 0.024	1.0 0.039	NA6907	49.9 11200	88.7 19900	10000	6700	0.0540	0.340 0.750
	35 1.3780	58 2.2835	22 0.866	43 1.6929	0.6 0.024	1.0 0.039	NKJS35	41.6 9350	60.7 13600	10000	6700	0.0481	0.235 0.518
38 1.4961	38 1.4961	53 2.0866	20 0.787	43 1.6929	0.3 0.012	2.0 0.079	NKJ38/20	29.0 6520	54.4 12200	9900	6400	0.0504	0.146 0.322
	38 1.4961	53 2.0866	30 1.181	43 1.6929	0.3 0.012	1.5 0.059	NKJ38/30	41.6 9350	86.6 19500	9900	6400	0.0565	0.196 0.432
40 1.5748	40 1.5748	55 2.1654	20 0.787	45 1.7717	0.3 0.012	2.0 0.079	NKJ40/20	29.5 6630	56.4 12700	9400	6100	0.0519	0.152 0.335
	40 1.5748	55 2.1654	30 1.181	45 1.7717	0.3 0.012	1.5 0.059	NKJ40/30	42.3 9510	89.8 20200	9400	6100	0.0582	0.229 0.505
	40 1.5748	62 2.4409	22 0.866	48 1.8898	0.6 0.024	1.5 0.059	NA4908	44.2 9940	67.8 15200	9100	5900	0.0519	0.248 0.547
	40 1.5748	62 2.4409	40 1.575	48 1.8898	0.6 0.024	1.5 0.059	NA6908	70.8 15900	124 27900	9100	5900	0.0717	0.473 1.043
	40 1.5748	65 2.5591	22 0.866	50 1.9685	1.0 0.039	1.0 0.039	NKJS40	45.5 10200	71.3 16000	8700	5700	0.0535	0.292 0.644
42 1.6535	42 1.6535	57 2.2441	20 0.787	47 1.8504	0.3 0.012	2.0 0.079	NKJ42/20	30.0 6740	58.5 13200	9000	5900	0.0534	0.159 0.351
	42 1.6535	57 2.2441	30 1.181	47 1.8504	0.3 0.012	1.5 0.059	NKJ42/30	39.9 8970	84.1 18900	9000	5900	0.0584	0.241 0.531
45 1.7717	45 1.7717	62 2.4409	25 0.984	50 1.9685	0.6 0.024	3.0 0.118	NKJ45/25	40.7 9150	79.3 17800	8500	5500	0.0580	0.223 0.492

⁽¹⁾ Max. axial displacement.

Continued on next page.



NEEDLE ROLLER BEARINGS
WITH INNER RINGS – continued

METRIC SERIES

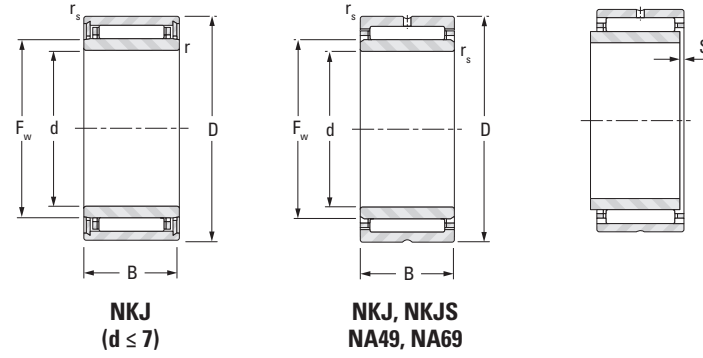

Shaft Dia.	d	D	B	F _w	r _s min	s ⁽¹⁾	Bearing Designation	Load Ratings		Speed Rating		C ₀	Approx. Wt.
								Dynamic	Static	Oil	Grease		
								C	C ₀				
mm in	mm in	mm in	mm in	mm in	mm in	mm in		kN lbf	min ⁻¹	kg lbs			
45 1.7717	45 1.7717	62 2.4409	35 1.378	50 1.9685	0.6 0.024	3.0 0.118	NKJ45/35	55.0 12400	117 26300	8500	5500	0.0636	0.345 0.761
	45 1.7717	68 2.6772	22 0.866	52 2.0472	0.6 0.024	2.0 0.079	NA4909	46.8 10500	74.8 16800	8400	5400	0.0550	0.291 0.642
	45 1.7717	68 2.6772	40 1.575	52 2.0472	0.6 0.024	1.5 0.059	NA6909	74.7 16800	137 30800	8400	5400	0.0759	0.55 1.232
	45 1.7717	72 2.8346	22 0.866	55 2.1654	1.0 0.039	1.0 0.039	NKJS45	47.9 10800	78.4 17600	7900	5100	0.0571	0.360 0.794
50 1.9685	50 1.9685	68 2.6772	25 0.984	55 2.1654	0.6 0.024	3.0 0.118	NKJ50/25	46.1 10400	87.3 19600	7800	5000	0.0605	0.288 0.635
	50 1.9685	68 2.6772	35 1.378	55 2.1654	0.6 0.024	3.0 0.118	NKJ50/35	62.3 14000	129 29000	7800	5000	0.0667	0.406 0.895
	50 1.9685	72 2.8346	22 0.866	58 2.2835	0.6 0.024	2.0 0.079	NA4910	48.9 11000	82.0 18400	7400	4800	0.0591	0.296 0.653
	50 1.9685	72 2.8346	40 1.575	58 2.2835	0.6 0.024	1.5 0.059	NA6910	75.7 17000	144 32400	7400	4800	0.0806	0.577 1.272
	50 1.9685	80 3.1496	28 1.102	60 2.3622	1.1 0.043	1.5 0.059	NKJS50	66.9 15000	103 23200	7300	4800	0.0612	0.523 1.153
55 2.1654	55 2.1654	72 2.8346	25 0.984	60 2.3622	0.6 0.024	3.0 0.118	NKJ55/25	44.3 9960	94.0 21100	7000	4600	0.0654	0.290 0.639
	55 2.1654	72 2.8346	35 1.378	60 2.3622	0.6 0.024	3.0 0.118	NKJ55/35	59.9 13500	139 31200	7000	4600	0.0721	0.410 0.904
	55 2.1654	80 3.1496	25 0.984	63 2.4803	1.0 0.039	2.5 0.098	NA4911	62.0 13900	107 24100	6900	4500	0.0645	0.426 0.939
	55 2.1654	80 3.1496	45 1.772	63 2.4803	1.0 0.039	2.5 0.098	NA6911	94.2 21200	172 38700	6900	4500	0.0852	0.800 1.764
	55 2.1654	85 3.3465	28 1.102	65 2.5591	1.1 0.043	1.5 0.059	NKJS55	71.0 16000	114 25600	6700	4400	0.0650	0.569 1.254
60 2.3622	60 2.3622	82 3.2283	25 0.984	68 2.6772	0.6 0.024	2.0 0.079	NKJ60/25	49.0 11000	101 22700	6200	4000	0.0691	0.440 0.970
	60 2.3622	82 3.2283	35 1.378	68 2.6772	0.6 0.024	2.5 0.098	NKJ60/35	66.2 14900	149 33500	6200	4000	0.0760	0.520 1.146
	60 2.3622	85 3.3465	25 0.984	68 2.6772	1.0 0.039	1.5 0.059	NA4912	64.8 14600	116 26100	6300	4100	0.0681	0.457 1.008
	60 2.3622	85 3.3465	45 1.772	68 2.6772	1.0 0.039	2.0 0.079	NA6912	99.3 22300	189 42500	6400	4100	0.0901	0.829 1.828
	60 2.3622	90 3.5433	28 1.102	70 2.7559	1.1 0.043	1.5 0.059	NKJS60	72.6 16300	120 27000	6200	4000	0.0679	0.607 1.338
65 2.5591	65 2.5591	90 3.5433	25 0.984	72 2.8346	1.0 0.039	1.5 0.059	NA4913	66.0 14800	121 27200	5900	3900	0.0705	0.489 1.078

⁽¹⁾ Max. axial displacement.

Continued on next page.

Shaft Dia.	d	D	B	F _w	r _s min	s ⁽¹⁾	Bearing Designation	Load Ratings		Speed Rating		C ₀	Approx. Wt.
								Dynamic	Static	Oil	Grease		
								C	C ₀				
mm in	mm in	mm in	mm in	mm in	mm in	mm in		kN lbf	min ⁻¹	kg lbs			
65 2.5591	65 2.5591	90 3.5433	25 0.984	73 2.8740	0.6 0.024	2.0 0.079	NKJ65/25	61.5 13800	119 26800	5800	3800	0.0717	0.500 1.102
	65 2.5591	90 3.5433	35 1.378	73 2.8740	0.6 0.024	2.0 0.079	NKJ65/35	82.5 18500	173 38900	5800	3800	0.0787	0.690 1.521
	65 2.5591	90 3.5433	45 1.772	72 2.8346	1.0 0.039	2.0 0.079	NA6913	107 24100	213 47900	6000	3900	0.0952	0.945 2.083
	65 2.5591	95 3.7402	28 1.102	75 2.9528	1.1 0.043	1.5 0.059	NKJS65	76.5 17200	132 29700	5800	3700	0.0716	0.655 1.444
70 2.7559	70 2.7559	95 3.7402	25 0.984	80 3.1496	1.0 0.039	2.0 0.079	NKJ70/25	65.0 14600	131 29400	5300	3400	0.0766	0.561 1.237
	70 2.7559	95 3.7402	35 1.378	80 3.1496	1.0 0.039	3.5 0.138	NKJ70/35	79.7 17900	184 41400	5300	3400	0.0846	0.779 1.717
	70 2.7559	100 3.9370	28 1.102	80 3.1496	1.1 0.043	1.5 0.059	NKJS70	80.1 18000	143 32100	5400	3500	0.0752	0.772 1.702
	70 2.7559	100 3.9370	30 1.181	80 3.1496	1.0 0.039	2.5 0.098	NA4914	86.3 19400	157 35300	5400	3500	0.0770	0.772 1.702
	70 2.7559	100 3.9370	54 2.126	80 3.1496	1.0 0.039	2.0 0.079	NA6914	137 30800	286 64300	5400	3500	0.1061	1.450 3.197
75 2.9528	75 2.9528	105 4.1339	25 0.984	85 3.3465	1.0 0.039	2.0 0.079	NKJ75/25	76.4 17200	137 30800	5000	3300	0.0764	0.640 1.411
	75 2.9528	105 4.1339	30 1.181	85 3.3465	1.0 0.039	2.5 0.098	NA4915	92.4 20800	175 39300	5000	3300	0.0812	0.817 1.801
	75 2.9528	105 4.1339	32 1.260	90 3.5433	1.1 0.043	1.5 0.059	NKJS75	91.5 20600	176 39600	4700	3100	0.0834	1.060 2.337
	75 2.9528	105 4.1339	35 1.378	85 3.3465	1.0 0.039	2.0 0.079	NKJ75/35	108 24300	214 48100	5000	3300	0.0854	1.050 2.315
	75 2.9528	105 4.1339	54 2.126	85 3.3465	1.0 0.039	2.0 0.079	NA6915	143 32100	308 69200	5000	3300	0.1110	1.554 3.426
80 3.1496	80 3.1496	110 4.3307	25 0.984	90 3.5433	1.0 0.039	2.0 0.079	NKJ80/25	79.5 17900	147 33000	4700	3100	0.0798	0.790 1.742
	80 3.1496	110 4.3307	30 1.181	90 3.5433	1.0 0.039	2.5 0.098	NA4916	91.5 20600	176 39600	4700	3100	0.0834	0.862 1.900
	80 3.1496	110 4.3307	32 1.260	95 3.7402	1.1 0.043	2.0 0.079	NKJS80	95.1 21400	188 42300	4500	2900	0.0869	1.140 2.513
	80 3.1496	110 4.3307	35 1.378	90 3.5433	1.0 0.039	2.0 0.079	NKJ80/35	113 25400	230 51700	4700	3100	0.0891	0.980 2.161
	80 3.1496	110 4.3307	54 2.126	90 3.5433	1.0 0.039	2.0 0.079	NA6916	126 28300	320 71900	4700	3000	0.1197	1.615 3.560
85 3.3465	85 3.3465	115 4.5276	26 1.024	95 3.7402	1.0 0.039	3.0 0.118	NKJ85/26	49.3 11100	114 25600	4400	2800	0.0839	0.862 1.900
	85 3.3465	115 4.5276	36 1.417	95 3.7402	1.0 0.039	2.0 0.079	NKJ85/36	114 25600	238 53500	4400	2800	0.0921	1.040 2.293
	85 3.3465	120 4.7244	35 1.378	100 3.9370	1.1 0.043	2.5 0.098	NA4917	110 24700	230 51700	4200	2800	0.0935	1.310 2.888
	85 3.3465	120 4.7244	63 2.480	100 3.9370	1.1 0.043	2.0 0.079	NA6917	150 33700	416 93500	4200	2700	0.1340	2.427 5.351
90 3.5433	90 3.5433	120 4.7244	26 1.024	100 3.9370	1.0 0.039	3.0 0.118	NKJ90/26	83.6 18800	163 36600	4200	2800	0.0857	0.780 1.720
	90 3.5433	120 4.7244	36 1.417	100 3.9370	1.0 0.039	2.5 0.098	NKJ90/36	118 26500	254 57100	4200	2800	0.0958	1.080 2.381
	90 3.5433	125 4.9213	35 1.378	105 4.1339	1.1 0.043	2.5 0.098	NA4918	114 25600	245 55100	4000	2600	0.0970	1.370 3.020

⁽¹⁾ Max. axial displacement.

Continued on next page.



NEEDLE ROLLER BEARINGS

NEEDLE ROLLER BEARINGS WITH INNER RINGS – continued

METRIC SERIES

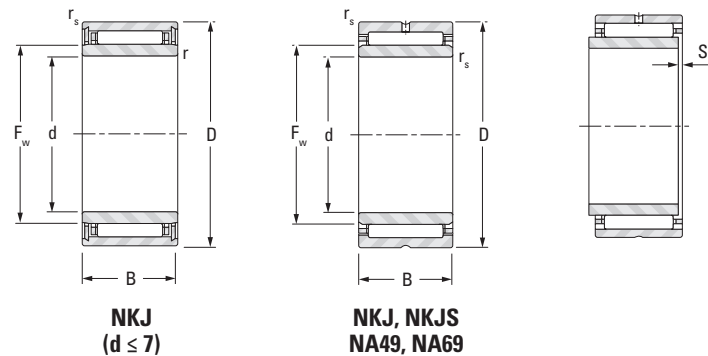

NKJ
($d \leq 7$)

NKJ, NKJS
NA49, NA69

Shaft Dia.	d	D	B	F _w	r _{s min}	s ⁽¹⁾	Bearing Designation	Load Ratings		Speed Rating		C ₉	Approx. Wt.
								Dynamic	Static	Oil	Grease		
								C	C ₀				
mm in	mm in	mm in	mm in	mm in	mm in	mm in		kN lbf	min ⁻¹			kg lbs	
90 3.5433	90 3.5433	125 4.9213	63 2.480	105 4.1339	1.1 0.043	2.0 0.079	NA6918	175 39300	427 96000	4000	2600	0.1323	2.640 5.820
95 3.7402	95 3.7402	125 4.9213	26 1.024	105 4.1339	1.0 0.039	2.5 0.098	NKJ95/26	52.2 11700	127 28600	3900	2600	0.0892	0.935 2.061
95 3.7402	95 3.7402	125 4.9213	36 1.417	105 4.1339	1.0 0.039	3.5 0.138	NKJ95/36	72.8 16400	195 43800	3900	2600	0.0992	1.300 2.866
95 3.7402	95 3.7402	130 5.1181	35 1.378	110 4.3307	1.1 0.043	2.5 0.098	NA4919	115 25900	253 56900	3800	2500	0.0999	1.430 3.153
95 3.7402	95 3.7402	130 5.1181	63 2.480	110 4.3307	1.1 0.043	2.0 0.079	NA6919	158 35500	458 103000	3800	2500	0.1434	2.670 5.88
100 3.9370	100 3.9370	130 5.1181	30 1.181	110 4.3307	1.1 0.043	2.0 0.079	NKJ100/30	103 23200	220 49500	3800	2500	0.0965	0.984 2.169
100 3.9370	100 3.9370	130 5.1181	40 1.575	110 4.3307	1.1 0.043	2.0 0.079	NKJ100/40	132 29700	301 67700	3800	2500	0.1043	1.410 3.109
100 3.9370	100 3.9370	135 5.3150	32 1.260	115 4.5276	1.1 0.043	2.0 0.079	NKJS100	104 23400	226 50800	3700	2400	0.0991	2.010 4.431
100 3.9370	100 3.9370	140 5.5118	40 1.575	115 4.5276	1.1 0.043	3.5 0.138	NA4920	139 31200	296 66500	3700	2400	0.1037	2.010 4.431
110 4.3307	110 4.3307	140 5.5118	30 1.181	120 4.7244	1.0 0.039	0.5 0.020	NA4822	90.3 20300	230 51700	3500	2300	0.1059	1.210 2.668
110 4.3307	110 4.3307	150 5.9055	40 1.575	125 4.9213	1.1 0.043	3.5 0.138	NA4922	147 33000	325 73100	3400	2200	0.1101	2.190 4.828
120 4.7244	120 4.7244	150 5.9055	30 1.181	130 5.1181	1.0 0.039	0.5 0.020	NA4824	94.2 21200	249 56000	3200	2100	0.1121	1.310 2.888
120 4.7244	120 4.7244	165 6.4961	45 1.772	135 5.3150	1.1 0.043	3.5 0.138	NA4924	177 39800	407 91500	3100	2000	0.1193	3.040 6.702
130 5.1181	130 5.1181	165 6.4961	35 1.378	145 5.7087	1.1 0.043	1.0 0.039	NA4826	112 25200	323 72600	2900	1900	0.1258	1.990 4.387
130 5.1181	130 5.1181	180 7.0866	50 1.969	150 5.9055	1.5 0.059	3.0 0.118	NA4926	201 45200	495 111000	2800	1800	0.1314	4.140 9.127
140 5.5118	140 5.5118	175 6.8898	35 1.378	155 6.1024	1.1 0.043	1.0 0.039	NA4828	116 26100	346 77800	2700	1700	0.1320	2.120 4.674
140 5.5118	140 5.5118	190 7.4803	50 1.969	160 6.2992	1.5 0.059	3.0 0.118	NA4928	214 48100	549 123000	2600	1700	0.1389	4.410 9.72
150 5.9055	150 5.9055	190 7.4803	40 1.575	165 6.4961	1.1 0.043	2.0 0.079	NA4830	142 31900	402 90400	2500	1600	0.1367	2.700 5.952
160 6.2992	160 6.2992	200 7.8740	40 1.575	175 6.8898	1.1 0.043	2.0 0.079	NA4832	146 32800	425 95500	2400	1500	0.1425	3.150 6.944

⁽¹⁾ Max. axial displacement.

Heavy-Duty Needle Roller Bearings

NEEDLE ROLLER BEARINGS WITHOUT INNER RINGS

METRIC SERIES

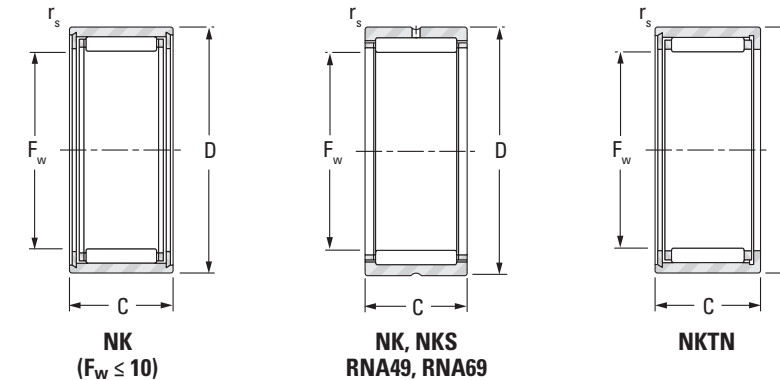

NK
($F_w \leq 10$)

NK, NKS
RNA49, RNA69

NKTN

Shaft Dia.	F _w	D	C	r _{s min}	Bearing Designation	Load Ratings		Speed Rating		C ₉	Approx. Wt.
						Dynamic	Static	Oil	Grease		
						C	C ₀				
mm in	mm in	mm in	mm in	mm in		kN lbf	min ⁻¹			kg lbs	
5 0.1969	5 0.1969	10 0.3937	10 0.394	0.2 0.006	NK5/10TN	2.18 490	1.71 384	47000	31000	0.0095	0.004 0.009
5 0.1969	5 0.1969	10 0.3937	12 0.472	0.2 0.006	NK5/12TN	3.04 683	2.63 591	47000	31000	0.0106	0.004 0.009
6 0.2362	6 0.2362	12 0.4724	10 0.394	0.2 0.006	NK6/10	3.19 717	2.90 652	44000	29000	0.0116	0.005 0.011
6 0.2362	6 0.2362	12 0.4724	12 0.472	0.2 0.006	NK6/12TN	3.07 690	2.74 616	44000	29000	0.0115	0.006 0.013
7 0.2756	7 0.2756	14 0.5512	10 0.394	0.3 0.012	NK7/10TN	2.74 616	2.44 549	42000	28000	0.0118	0.007 0.015
7 0.2756	7 0.2756	14 0.5512	12 0.472	0.3 0.012	NK7/12TN	3.40 764	3.22 724	42000	28000	0.0127	0.009 0.020
8 0.3150	8 0.3150	15 0.5906	12 0.472	0.3 0.012	NK8/12	4.57 1030	4.89 1100	41000	26000	0.0148	0.011 0.024
8 0.3150	8 0.3150	15 0.5906	12 0.472	0.3 0.012	NK8/12ASR1	4.57 1030	4.89 1100	41000	26000	0.0148	0.011 0.024
8 0.3150	8 0.3150	15 0.5906	16 0.630	0.3 0.012	NK8/16	5.22 1170	5.78 1300	41000	26000	0.0154	0.013 0.029
9 0.3543	9 0.3543	16 0.6299	12 0.472	0.3 0.012	NK9/12	4.27 960	4.60 1030	40000	26000	0.0153	0.012 0.026
9 0.3543	9 0.3543	16 0.6299	16 0.630	0.3 0.012	NK9/16	5.57 1250	6.47 1450	40000	26000	0.0170	0.015 0.033
10 0.3937	10 0.3937	17 0.6693	12 0.472	0.3 0.012	NK10/12	5.40 1210	6.43 1450	39000	25000	0.0174	0.013 0.029
10 0.3937	10 0.3937	17 0.6693	16 0.630	0.3 0.012	NK10/16TN	5.30 1190	6.27 1410	39000	25000	0.0173	0.015 0.033
12 0.4724	12 0.4724	19 0.7480	12 0.472	0.3 0.012	NK12/12	6.86 1540	7.60 1710	30000	19000	0.0195	0.013 0.029
12 0.4724	12 0.4724	19 0.7480	16 0.630	0.3 0.012	NK12/16	6.78 1520	9.03 2030	37000	24000	0.0204	0.018 0.040
14 0.5512	14 0.5512	22 0.8661	13 0.512	0.3 0.012	RNA4900	9.39 2110	10.3 2320	24000	16000	0.0211	0.018 0.040
14 0.5512	14 0.5512	22 0.8661	16 0.630	0.3 0.012	NK14/16	12.4 2790	14.8 3330	24000	16000	0.0231	0.023 0.051
14 0.5512	14 0.5512	22 0.8661	20 0.787	0.3 0.012	NK14/20	14.7 3300	18.4 4140	24000	16000	0.0244	0.028 0.06
15 0.5906	15 0.5906	23 0.9055	16 0.630	0.3 0.012	NK15/16	12.4 2790	15.0 3370	24000	15000	0.0238	0.024 0.053
15 0.5906	15 0.5906	23 0.9055	20 0.787	0.3 0.012	NK15/20	14.7 3300	18.6 4180	24000	15000	0.0252	0.031 0.068
16 0.6299	16 0.6299	24 0.9449	13 0.512	0.3 0.012	RNA4901	10.5 2360	12.3 2770	28000	18000	0.0233	0.020 0.044
16 0.6299	16 0.6299	24 0.9449	16 0.630	0.3 0.012	NK16/16	15.4 3460	20.2 4540	28000	18000	0.0250	0.025 0.055

Continued on next page.



NEEDLE ROLLER BEARINGS
WITHOUT INNER RINGS — continued

METRIC SERIES

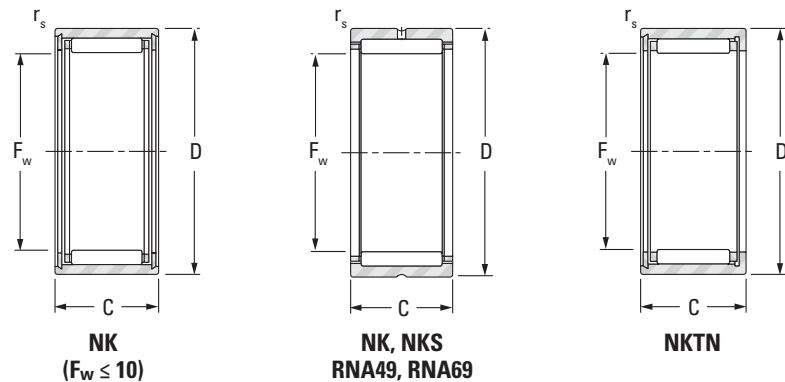

Shaft Dia. mm in	F _w mm in	D mm in	C mm in	r _{s min} mm in	Bearing Designation	Load Ratings		Speed Rating		C _g	Approx. Wt. kg lbs
						Dynamic C	Static C ₀	Oil	Grease		
						kN lbf		min ⁻¹			
16 0.6299	16 0.6299	24 0.9449	20 0.787	0.3 0.012	NK16/20	16.1 3620	21.3 4790	28000	18000	0.0264	0.036 0.079
						16.1 3620	21.3 4790	28000	18000		0.0267
17 0.6693	17 0.6693	25 0.9843	16 0.630	0.3 0.012	NK17/16	13.6 3060	17.5 3930	27000	17000	0.0261	0.027 0.060
						15.4 3460	20.4 4590	27000	17000		0.0271
18 0.7087	18 0.7087	26 1.0236	16 0.630	0.3 0.012	NK18/16	13.6 3060	17.7 3980	25000	16000	0.0268	0.028 0.062
						16.1 3620	22.0 4950	25000	16000		0.0283
19 0.7480	19 0.7480	27 1.0630	16 0.630	0.3 0.012	NK19/16	14.1 3170	19.0 4270	24000	15000	0.0279	0.029 0.064
						18.8 4230	23.6 5310	24000	15000		0.0295
20 0.7874	20 0.7874	28 1.1024	13 0.512	0.3 0.012	RNA4902	11.8 2650	15.3 3440	22000	14000	0.0270	0.023 0.051
						14.1 3170	19.1 4290	22000	14000		0.0285
20 0.7874	20 0.7874	28 1.1024	16 0.630	0.3 0.012	NK20/16	17.5 3930	25.3 5690	22000	14000	0.0306	0.038 0.084
						18.4 4140	26.9 6050	22000	14000		0.0311
20 0.7874	20 0.7874	32 1.2598	20 0.787	0.6 0.024	NKS20	24.4 5490	26.7 6000	24000	15000	0.0290	0.058 0.128
						15.3 3440	21.6 4860	21000	14000		0.0301
21 0.8268	21 0.8268	29 1.1417	20 0.787	0.3 0.012	NK21/20	18.1 4070	26.9 6050	21000	14000	0.0317	0.040 0.088
						12.2 2740	16.4 3690	20000	13000		0.0286
22 0.8661	22 0.8661	30 1.1811	13 0.512	0.3 0.012	RNA4903	15.2 3420	21.7 4880	20000	13000	0.0307	0.033 0.073
						18.0 4050	27.0 6070	20000	13000		0.0324
22 0.8661	22 0.8661	30 1.1811	23 0.906	0.3 0.012	RNA6903	19.8 4450	30.6 6880	20000	13000	0.0334	0.056 0.123
						22.9 5150	27.1 6090	21000	14000		0.0310
24 0.9449	24 0.9449	32 1.2598	16 0.630	0.3 0.012	NK24/16	16.2 3640	24.3 5460	18000	12000	0.0328	0.035 0.077

Continued on next page.

Shaft Dia. mm in	F _w mm in	D mm in	C mm in	r _{s min} mm in	Bearing Designation	Load Ratings		Speed Rating		C _g	Approx. Wt. kg lbs
						Dynamic C	Static C ₀	Oil	Grease		
						kN lbf		min ⁻¹			
24 0.9449	24 0.9449	32 1.2598	20 0.787	0.3 0.012	NK24/20	19.3 4340	30.3 6810	18000	12000	0.0346	0.045 0.099
						29.1 6540	32.8 7370	20000	13000		0.0325
25 0.9843	25 0.9843	33 1.2992	16 0.630	0.3 0.012	NK25/16	16.1 3620	24.4 5490	17000	11000	0.0334	0.037 0.082
						19.1 4290	30.4 6830	17000	11000		0.0353
25 0.9843	25 0.9843	37 1.4567	20 0.787	0.3 0.012	RNA4904	21.3 4790	25.5 5730	18000	12000	0.0318	0.061 0.134
						36.6 8230	51.0 11500	18000	12000		0.0378
25 0.9843	25 0.9843	38 1.4961	20 0.787	0.6 0.024	NKS25	29.1 6540	33.0 7420	19000	12000	0.0331	0.076 0.168
						16.6 3730	25.7 5780	17000	11000		0.0344
26 1.0236	26 1.0236	34 1.3386	16 0.630	0.3 0.012	NK26/16	19.7 4430	32.0 7190	17000	11000	0.0363	0.048 0.106
						22.6 5080	34.4 7730	16000	10000		0.0373
28 1.1024	28 1.1024	37 1.4567	20 0.787	0.3 0.012	NK28/20	28.0 6320	30.0 6730	16000	10000	0.0427	0.088 0.194
						23.3 5240	29.6 6650	16000	10000		0.0346
28 1.1024	28 1.1024	39 1.5354	17 0.669	0.3 0.012	RNA49/22	30.6 6880	50.7 11400	16000	10000	0.0487	0.107 0.236
						30.3 6810	38.4 8630	16000	11000		0.0364
29 1.1417	29 1.1417	42 1.6535	20 0.787	0.6 0.024	NKS28	23.4 5260	36.4 8180	15000	9800	0.0383	0.059 0.130
						29.8 6700	56.4 12700	15000	9700		0.0438
30 1.1811	30 1.1811	40 1.5748	20 0.787	0.3 0.012	NK29/20	24.2 5440	38.3 8610	15000	9500	0.0394	0.071 0.157
						23.4 5260	36.4 8180	15000	9800		0.0383
30 1.1811	30 1.1811	40 1.5748	20 0.787	0.3 0.012	NK30/20	29.8 6700	56.4 12700	15000	9700	0.0438	0.090 0.198
						34.7 7800	61.0 13700	15000	9500		0.0442
30 1.1811	30 1.1811	42 1.6535	17 0.669	0.3 0.012	RNA4905	24.3 5460	31.7 7130	15000	9700	0.0362	0.071 0.157
						39.7 8920	59.6 13400	15000	9700		0.0424
30 1.1811	30 1.1811	42 1.6535	30 1.181	0.3 0.012	RNA6905	34.3 7710	42.8 9620	15000	9900	0.0380	0.114 0.251
						24.8 5580	40.4 9080	14000	8800		0.0411
32 1.2598	32 1.2598	42 1.6535	20 0.787	0.3 0.012	NK32/20	35.6 8000	64.3 14500	14000	8800	0.0461	0.112 0.247
						25.1 5640	33.8 7600	14000	9000		0.0378
32 1.2598	32 1.2598	45 1.7717	30 1.181	0.3 0.012	RNA49/28	43.2 9710	62.5 14100	14000	9100	0.0612	0.140 0.309
						36.0 8090	46.2 10400	14000	9200		0.0398
35 1.3780	35 1.3780	47 1.8504	22 0.866	0.6 0.024	NKS32	26.1 5870	44.4 9980	12000	8000	0.0437	0.081 0.179
						37.4 8410	70.6 15900	12000	8000		0.0491

Continued on next page.



NEEDLE ROLLER BEARINGS
WITHOUT INNER RINGS — continued

METRIC SERIES

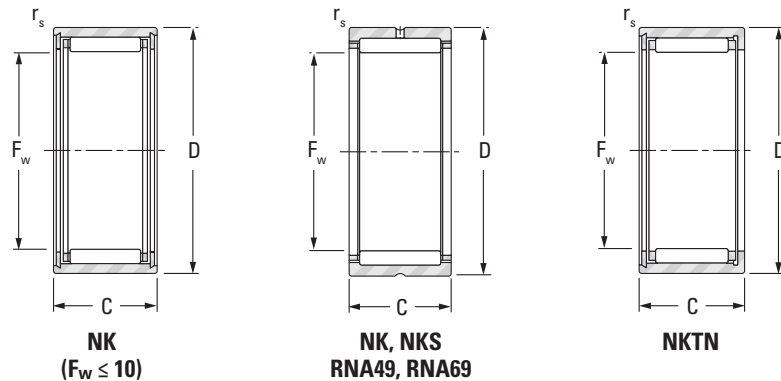

Shaft Dia. mm in	F _w mm in	D mm in	C mm in	r _{s min} mm in	Bearing Designation	Load Ratings		Speed Rating		C _g	Approx. Wt. kg lbs
						Dynamic	Static	Oil	Grease		
						C	C ₀				
						kN lbf		min ⁻¹			
35 1.3780	35 1.3780	47 1.8504	18 0.709	0.3 0.012	RNA4906	25.9 5820	36.0 8090	13000	8200	0.0399	0.081 0.179
	35 1.3780	47 1.8504	30 1.181	0.3 0.012	RNA6906	42.6 9580	68.2 15300	13000	8200	0.0467	0.148 0.326
	35 1.3780	50 1.9685	22 0.866	0.6 0.024	NKS35	37.5 8430	49.9 11200	13000	8400	0.0421	0.130 0.287
37 1.4567	37 1.4567	47 1.8504	20 0.787	0.3 0.012	NK37/20	26.6 5980	46.4 10400	12000	7600	0.0453	0.084 0.185
	37 1.4567	47 1.8504	30 1.181	0.3 0.012	NK37/30	38.2 8590	73.9 16600	12000	7600	0.0508	0.128 0.282
	37 1.4567	52 2.0472	22 0.866	0.6 0.024	NKS37	39.0 8770	53.4 12000	12000	7900	0.0438	0.134 0.295
38 1.4961	38 1.4961	48 1.8898	20 0.787	0.3 0.012	NK38/20	21.7 4880	40.9 9190	11000	7300	0.0456	0.087 0.192
	38 1.4961	48 1.8898	30 1.181	0.3 0.012	NK38/30	31.9 7170	67.0 15100	11000	7300	0.0516	0.131 0.289
40 1.5748	40 1.5748	50 1.9685	20 0.787	0.3 0.012	NK40/20	27.8 6250	50.4 11300	11000	7000	0.0479	0.089 0.196
	40 1.5748	50 1.9685	30 1.181	0.3 0.012	NK40/30	40.0 8990	80.2 18000	11000	7000	0.0537	0.137 0.302
	40 1.5748	52 2.0472	20 0.787	0.6 0.024	RNA49/32	32.0 7190	49.3 11100	11000	7100	0.0457	0.100 0.220
	40 1.5748	52 2.0472	36 1.417	0.6 0.024	RNA69/32	48.6 10900	84.5 19000	11000	7100	0.0620	0.185 0.408
	40 1.5748	55 2.1654	22 0.866	0.6 0.024	NKS40	40.3 9060	57.0 12800	11000	7200	0.0460	0.140 0.309
42 1.6535	42 1.6535	52 2.0472	20 0.787	0.3 0.012	NK42/20	28.3 6360	52.4 11800	10000	6600	0.0494	0.085 0.187
	42 1.6535	52 2.0472	30 1.181	0.3 0.012	NK42/30	40.7 9150	83.5 18800	10000	6600	0.0554	0.141 0.311
	42 1.6535	55 2.1654	20 0.787	0.6 0.024	RNA4907	32.8 7370	51.7 11600	10000	6700	0.0454	0.114 0.251
	42 1.6535	55 2.1654	36 1.417	0.6 0.024	RNA6907	49.9 11200	88.7 19900	10000	6700	0.0641	0.218 0.481
43 1.6929	43 1.6929	53 2.0866	20 0.787	0.3 0.012	NK43/20	29.0 6520	54.4 12200	9900	6400	0.0504	0.096 0.212
	43 1.6929	53 2.0866	30 1.181	0.3 0.012	NK43/30	41.6 9350	86.6 19500	9900	6400	0.0565	0.134 0.295
	43 1.6929	58 2.2835	22 0.866	0.6 0.024	NKS43	41.6 9350	60.7 13600	10000	6700	0.0481	0.150 0.331
45 1.7717	45 1.7717	55 2.1654	20 0.787	0.3 0.012	NK45/20	29.5 6630	56.4 12700	9400	6100	0.0519	0.100 0.220
	45 1.7717	55 2.1654	30 1.181	0.3 0.012	NK45/30	42.3 9510	89.8 20200	9400	6100	0.0582	0.151 0.333

Continued on next page.

Shaft Dia. mm in	F _w mm in	D mm in	C mm in	r _{s min} mm in	Bearing Designation	Load Ratings		Speed Rating		C _g	Approx. Wt. kg lbs
						Dynamic	Static	Oil	Grease		
						C	C ₀				
						kN lbf		min ⁻¹			
45 1.7717	45 1.7717	60 2.3622	22 0.866	0.6 0.024	NKS45	43.0 9670	64.2 14400	9800	6400	0.0498	0.156 0.344
	47 1.8504	57 2.2441	20 0.787	0.3 0.012	NK47/20	30.0 6740	58.5 13200	9000	5900	0.0534	0.104 0.229
	47 1.8504	57 2.2441	30 1.181	0.3 0.012	NK47/30	43.0 9670	93.1 20900	9000	5900	0.0599	0.158 0.348
48 1.8898	48 1.8898	62 2.4409	22 0.866	0.6 0.024	RNA4908	44.2 9940	67.8 15200	9100	5900	0.0519	0.154 0.340
	48 1.8898	62 2.4409	40 1.575	0.6 0.024	RNA6908	70.8 15900	124 27900	9100	5900	0.0717	0.300 0.661
	50 1.9685	62 2.4409	25 0.984	0.3 0.012	NK50/25	40.7 9150	79.3 17800	8500	5500	0.0578	0.171 0.377
	50 1.9685	62 2.4409	35 1.378	0.6 0.024	NK50/35	55.0 12400	117 26300	8500	5500	0.0636	0.242 0.534
	50 1.9685	65 2.5591	22 0.866	1.0 0.039	NKS50	45.5 10200	71.3 16000	8700	5700	0.0535	0.170 0.375
52 2.0472	52 2.0472	68 2.6772	22 0.866	0.6 0.024	RNA4909	46.8 10500	74.8 16800	8400	5400	0.0550	0.201 0.443
	52 2.0472	68 2.6772	40 1.575	0.6 0.024	RNA6909	74.7 16800	137 30800	8400	5400	0.0759	0.392 0.864
	55 2.1654	68 2.6772	25 0.984	0.6 0.024	NK55/25	46.1 10400	87.3 19600	7800	5000	0.0605	0.207 0.456
	55 2.1654	68 2.6772	35 1.378	0.6 0.024	NK55/35	62.3 14000	129 29000	7800	5000	0.0667	0.293 0.646
	55 2.1654	72 2.8346	22 0.866	1.0 0.039	NKS55	47.9 10800	78.4 17600	7900	5100	0.0571	0.225 0.496
58 2.2835	58 2.2835	72 2.8346	22 0.866	0.6 0.024	RNA4910	48.9 11000	82.0 18400	7400	4800	0.0591	0.179 0.395
	58 2.2835	72 2.8346	40 1.575	0.6 0.024	RNA6910	75.7 17000	144 32400	7400	4800	0.0806	0.364 0.802
	60 2.3622	72 2.8346	25 0.984	0.6 0.024	NK60/25	44.3 9960	94.0 21100	7000	4400	0.0654	0.202 0.445
	60 2.3622	72 2.8346	35 1.378	0.6 0.024	NK60/35	59.9 13500	139 31200	7000	4400	0.0721	0.286 0.631
	60 2.3622	80 3.1496	28 1.102	1.1 0.043	NKS60	66.9 15000	103 23200	7300	4800	0.0612	0.337 0.743
63 2.4803	63 2.4803	80 3.1496	25 0.984	1.0 0.039	RNA4911	62.0 13900	107 24100	6900	4500	0.0645	0.285 0.628
	63 2.4803	80 3.1496	45 1.772	1.0 0.039	RNA6911	94.2 21200	172 38700	6900	4500	0.0852	0.540 1.190
	65 2.5591	78 3.0709	25 0.984	0.6 0.024	NK65/25	48.2 10800	97.7 22000	6500	4200	0.0671	0.257 0.567
	65 2.5591	78 3.0709	35 1.378	0.6 0.024	NK65/35	65.2 14700	144 32400	6500	4200	0.0739	0.298 0.657
	65 2.5591	85 3.3465	28 1.102	1.1 0.043	NKS65	71.0 16000	114 25600	6700	4200	0.0650	0.362 0.798
68 2.6772	68 2.6772	82 3.2283	25 0.984	0.6 0.024	NK68/25	49.0 11000	101 22700	6200	4000	0.0691	0.287 0.633
	68 2.6772	82 3.2283	35 1.378	0.6 0.024	NK68/35	66.2 14900	149 33500	6200	4000	0.0760	0.350 0.772
	68 2.6772	85 3.3465	25 0.984	1.0 0.039	RNA4912	64.8 14600	116 26100	6300	4100	0.0681	0.304 0.670
	68 2.6772	85 3.3465	45 1.772	1.0 0.039	RNA6912	99.3 22300	189 42500	6300	4100	0.0901	0.546 1.204
70 2.7559	70 2.7559	85 3.3465	25 0.984	0.6 0.024	NK70/25	43.6 9800	87.9 19800	6000	3900	0.0705	0.298 0.657

Continued on next page.



NEEDLE ROLLER BEARINGS
WITHOUT INNER RINGS – continued

METRIC SERIES

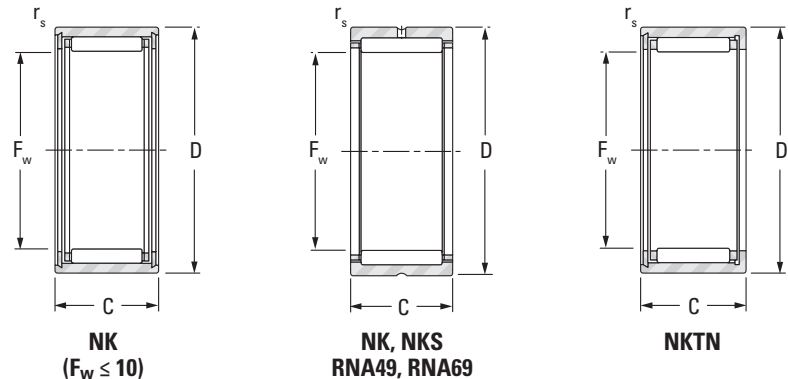

Shaft Dia. mm in	F _w mm in	D mm in	C mm in	r _s min mm in	Bearing Designation	Load Ratings		Speed Rating		C _g	Approx. Wt. kg lbs
						Dynamic	Static	Oil	Grease		
						C	C ₀				
						kN lbf		min ⁻¹			
70 2.7559	70 2.7559	85 3.3465	35 1.378	0.6 0.024	NK70/35	62.2 14000	139 31200	6000	3900	0.0757	0.411 0.906
	70 2.7559	90 3.5433	28 1.102	1.1 0.043	NKS70	72.6 16300	120 27000	6200	4000	0.0679	0.383 0.844
72 2.8346	72 2.8346	90 3.5433	25 0.984	1.0 0.039	RNA4913	66.0 14800	121 27200	5900	3900	0.0705	0.346 0.763
	72 2.8346	90 3.5433	45 1.772	1.0 0.039	RNA6913	107 24100	213 47900	5900	3900	0.0952	0.679 1.497
73 2.8740	73 2.8740	90 3.5433	25 0.984	0.6 0.024	NK73/25	61.5 13800	119 26800	5800	3800	0.0717	0.320 0.705
	73 2.8740	90 3.5433	35 1.378	0.6 0.024	NK73/35	82.5 18500	173 38900	5800	3800	0.0787	0.450 0.992
75 2.9528	75 2.9528	92 3.6220	25 0.984	0.6 0.024	NK75/25	43.7 9820	90.2 20300	5600	3600	0.0702	0.364 0.802
	75 2.9528	92 3.6220	35 1.378	0.6 0.024	NK75/35	60.9 13700	138 31000	5600	3600	0.0780	0.518 1.142
	75 2.9528	95 3.7402	28 1.102	1.1 0.043	NKS75	76.5 17200	132 29700	5800	3700	0.0716	0.413 0.911
80 3.1496	80 3.1496	95 3.7402	25 0.984	1.0 0.039	NK80/25	65.0 14600	131 29400	5300	3400	0.0766	0.331 0.730
	80 3.1496	95 3.7402	35 1.378	1.0 0.039	NK80/35	79.7 17900	184 41400	5300	3400	0.0846	0.380 0.838
	80 3.1496	100 3.9370	30 1.181	1.0 0.039	RNA4914	86.3 19400	157 35300	5400	3500	0.0770	0.502 1.107
	80 3.1496	100 3.9370	54 2.126	1.0 0.039	RNA6914	137 30800	286 64300	5400	6500	0.1061	0.946 2.086
85 3.3465	85 3.3465	105 4.1339	25 0.984	1.0 0.039	NK85/25	76.4 17200	137 30800	5000	3300	0.0764	0.506 1.116
	85 3.3465	105 4.1339	30 1.181	1.0 0.039	RNA4915	92.4 20800	175 39300	5000	3300	0.0812	0.528 1.164
	85 3.3465	105 4.1339	35 1.378	1.0 0.039	NK85/35	108 24300	214 48100	5000	3300	0.0854	0.610 1.345
	85 3.3465	105 4.1339	54 2.126	1.0 0.039	RNA6915	143 32100	308 69200	5000	3300	0.1110	1.020 2.249
90 3.5433	90 3.5433	110 4.3307	25 0.984	1.0 0.039	NK90/25	79.5 17900	147 33000	4700	3100	0.0798	0.450 0.992
	90 3.5433	110 4.3307	30 1.181	1.0 0.039	RNA4916	91.5 20600	176 39600	4700	3100	0.0834	0.556 1.226
	90 3.5433	110 4.3307	35 1.378	1.0 0.039	NK90/35	113 25400	230 51700	4700	3100	0.0891	0.745 1.642
	90 3.5433	110 4.3307	54 2.126	1.0 0.039	RNA6916	126 28300	320 71900	4700	3100	0.1197	1.050 2.315
95 3.7402	95 3.7402	115 4.5276	26 1.024	1.0 0.039	NK95/26	49.3 11100	114 25600	4400	2800	0.0829	0.572 1.261

Continued on next page.

Shaft Dia. mm in	F _w mm in	D mm in	C mm in	r _s min mm in	Bearing Designation	Load Ratings		Speed Rating		C _g	Approx. Wt. kg lbs
						Dynamic	Static	Oil	Grease		
						C	C ₀				
						kN lbf		min ⁻¹			
95 3.7402	95 3.7402	115 4.5276	36 1.417	1.0 0.039	NK95/36	114 25600	238 53500	4500	2900	0.0921	0.803 1.770
100 3.9370	100 3.9370	120 4.7244	26 1.024	1.0 0.039	NK100/26	83.6 18800	163 36600	4200	2800	0.0857	0.530 1.168
	100 3.9370	120 4.7244	35 1.378	1.1 0.043	RNA4917	110 24700	230 51700	4200	2800	0.0935	0.715 1.576
	100 3.9370	120 4.7244	36 1.417	1.0 0.039	NK100/36	118 26500	254 57100	4200	2800	0.0958	0.658 1.451
	100 3.9370	120 4.7244	63 2.480	1.1 0.043	RNA6917	150 33700	416 93500	4200	2800	0.1340	1.350 2.976
105 4.1339	105 4.1339	125 4.9213	26 1.024	1.0 0.039	NK105/26	52.2 11700	127 28600	3900	2600	0.0892	0.595 1.312
	105 4.1339	125 4.9213	35 1.378	1.1 0.043	RNA4918	114 25600	245 55100	4000	2600	0.0970	0.746 1.645
	105 4.1339	125 4.9213	63 2.480	1.1 0.043	RNA6918	154 34600	437 98200	4000	2600	0.1323	1.500 3.30
110 4.3307	110 4.3307	130 5.1181	30 1.181	1.1 0.043	NK110/30	103 23200	220 49500	3800	2500	0.0965	0.660 1.455
	110 4.3307	130 5.1181	35 1.378	1.1 0.043	RNA4919	115 25900	253 56900	3800	2500	0.0999	0.777 1.713
	110 4.3307	130 5.1181	40 1.575	1.1 0.043	NK110/40	132 29700	132 29700	3800	2500	0.1043	0.900 1.984
	110 4.3307	130 5.1181	63 2.480	1.1 0.043	RNA6919	158 35500	458 103000	3800	2500	0.1434	1.470 3.241
115 4.5276	115 4.5276	140 5.5118	40 1.575	1.1 0.043	RNA4920	139 31200	296 66500	3700	2400	0.1037	1.220 2.690
120 4.7244	120 4.7244	140 5.5118	30 1.181	1.0 0.039	RNA4822	90.3 20300	230 51700	3500	2300	0.1059	0.785 1.731
125 4.9213	125 4.9213	150 5.9055	40 1.575	1.1 0.043	RNA4922	147 33000	325 73100	3400	2200	0.1101	1.320 2.910
130 5.1181	130 5.1181	150 5.9055	30 1.181	1.0 0.039	RNA4824	94.1 21200	249 56000	3200	2100	0.1121	0.850 1.874
135 5.3150	135 5.3150	165 6.4961	45 1.772	1.1 0.043	RNA4924	177 39800	407 91500	3100	2000	0.1193	1.980 4.365
145 5.7087	145 5.7087	165 6.4961	35 1.378	1.0 0.039	RNA4826	112 25200	323 72600	2900	1900	0.1258	1.100 2.425
150 5.9055	150 5.9055	180 7.0866	50 1.969	1.5 0.059	RNA4926	201 45200	495 111000	2800	1800	0.1314	2.420 5.335
155 6.1024	155 6.1024	175 6.8898	35 1.378	1.1 0.043	RNA4828	116 26100	346 77800	2700	1700	0.1320	1.170 2.579
160 6.2992	160 6.2992	190 7.4803	50 1.969	1.5 0.059	RNA4928	214 48100	549 123000	2600	1700	0.1389	2.560 5.644
165 6.4961	165 6.4961	190 7.4803	40 1.575	1.1 0.043	RNA4830	142 31900	402 90400	2500	1600	0.1367	1.540 3.395
175 6.8898	175 6.8898	200 7.8740	40 1.575	1.1 0.043	RNA4832	146 32800	425 95500	2400	1500	0.1425	1.910 4.211



NEEDLE ROLLER BEARINGS

SEALED NEEDLE ROLLER BEARINGS WITH INNER RINGS

METRIC SERIES

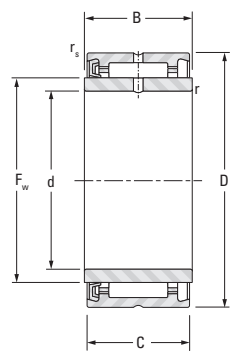

NA49RS

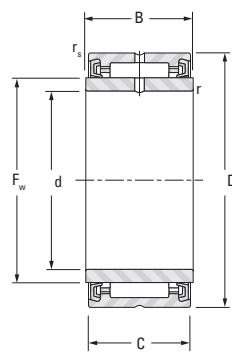

NA49.2RS

Shaft Dia.	d	D	B	C	F _w	r _s min	Bearing Designation	Load Ratings		Speed Rating Grease	C _g	Approx. Wt.
								Dynamic	Static			
								C	C ₀			
mm in	mm in	mm in	mm in	mm in	mm in	mm in		kN lbf	min ⁻¹		kg lbs	
10 0.3937	10 0.3937	22 0.8661	14 0.551	13 0.512	14 0.5512	0.3 0.012	NA4900RS	7.76 1740	8.06 1810	14000	0.0199	0.027 0.060
	10 0.3937	22 0.8661	14 0.551	13 0.512	14 0.5512	0.3 0.012	NA4900.2RS	7.76 1740	8.06 1810	14000	0.0199	0.027 0.060
12 0.4724	12 0.4724	24 0.9449	14 0.551	13 0.512	16 0.6299	0.3 0.012	NA4901RS	8.64 1940	9.59 2160	12000	0.0219	0.031 0.068
	12 0.4724	24 0.9449	14 0.551	13 0.512	16 0.6299	0.3 0.012	NA4901.2RS	8.64 1940	9.59 2160	12000	0.0219	0.031 0.068
15 0.5906	15 0.5906	28 1.1024	14 0.551	13 0.512	20 0.7874	0.3 0.012	NA4902RS	9.77 2200	12.0 2700	9700	0.0254	0.041 0.090
	15 0.5906	28 1.1024	14 0.551	13 0.512	20 0.7874	0.3 0.012	NA4902.2RS	9.77 2200	12.0 2700	9700	0.0254	0.041 0.090
17 0.6693	17 0.6693	30 1.1811	14 0.551	13 0.512	22 0.8661	0.3 0.012	NA4903RS	10.1 2270	12.8 2880	8800	0.0269	0.044 0.097
	17 0.6693	30 1.1811	14 0.551	13 0.512	22 0.8661	0.3 0.012	NA4903.2RS	10.1 2270	12.8 2880	8800	0.0269	0.044 0.097
20 0.7874	20 0.7874	37 1.4567	18 0.709	17 0.669	25 0.9843	0.3 0.012	NA4904RS	18.5 4160	21.2 4770	7800	0.0309	0.087 0.192
	20 0.7874	37 1.4567	18 0.709	17 0.669	25 0.9843	0.3 0.012	NA4904.2RS	18.5 4160	21.2 4770	7800	0.0304	0.087 0.192
25 0.9843	25 0.9843	42 1.6535	18 0.709	17 0.669	30 1.1811	0.3 0.012	NA4905RS	21.0 4720	26.4 5930	6500	0.0346	0.106 0.234
	25 0.9843	42 1.6535	18 0.709	17 0.669	30 1.1811	0.3 0.012	NA4905.2RS	21.0 4720	26.4 5930	6500	0.0346	0.106 0.234
30 1.1811	30 1.1811	47 1.8504	18 0.709	17 0.669	35 1.3780	0.3 0.012	NA4906RS	22.5 5060	30.0 6740	5500	0.0381	0.119 0.262
	30 1.1811	47 1.8504	18 0.709	17 0.669	35 1.3780	0.3 0.012	NA4906.2RS	22.5 5060	30.0 6740	5500	0.0381	0.119 0.262
35 1.3780	35 1.3780	55 2.1654	21 0.827	20 0.787	42 1.6535	0.6 0.024	NA4907RS	29.1 6540	44.4 9980	4600	0.0454	0.198 0.437
	35 1.3780	55 2.1654	21 0.827	20 0.787	42 1.6535	0.6 0.024	NA4907.2RS	29.1 6540	44.4 9980	4600	0.0454	0.198 0.437
40 1.5748	40 1.5748	62 2.4409	23 0.906	22 0.866	48 1.8898	0.6 0.024	NA4908RS	38.6 8680	57.0 12800	4000	0.0497	0.263 0.580
	40 1.5748	62 2.4409	23 0.906	22 0.866	48 1.8898	0.6 0.024	NA4908.2RS	38.6 8680	57.0 12800	4000	0.0497	0.263 0.580
45 1.7717	45 1.7717	68 2.6772	23 0.906	22 0.866	52 2.0472	0.6 0.024	NA4909RS	39.4 8860	60.0 13500	3700	0.0521	0.303 0.668
	45 1.7717	68 2.6772	23 0.906	22 0.866	52 2.0472	0.6 0.024	NA4909.2RS	39.4 8860	60.0 13500	3700	0.0521	0.303 0.668
50 1.9685	50 1.9685	72 2.8346	23 0.906	22 0.866	58 2.2835	0.6 0.024	NA4910RS	41.2 9260	65.8 14800	3300	0.0559	0.309 0.681
	50 1.9685	72 2.8346	23 0.906	22 0.866	58 2.2835	0.6 0.024	NA4910.2RS	41.2 9260	65.8 14800	3300	0.0559	0.309 0.681

Heavy-Duty Needle Roller Bearings

SEALED NEEDLE ROLLER BEARINGS WITHOUT INNER RINGS

METRIC SERIES

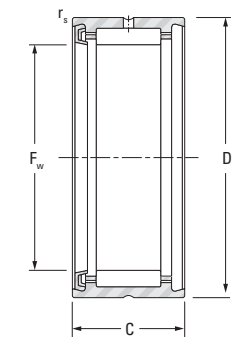

RNA49RS

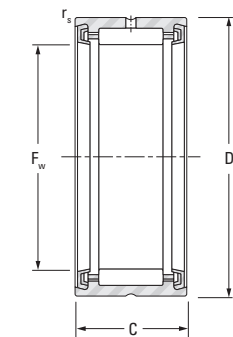

RNA49.2RS

Shaft Dia.	F _w	D	C	r _s min	Bearing Designation	Load Ratings		Speed Rating Grease	C _g	Approx. Wt.
						Dynamic	Static			
						C	C ₀			
mm in	mm in	mm in	mm in	mm in		kN lbf	min ⁻¹		kg lbs	
14 0.5512	14 0.5512	22 0.8661	13 0.512	0.3 0.012	RNA4900RS	7.76 1740	8.06 1810	14000	0.0199	0.019 0.042
	14 0.5512	22 0.8661	13 0.512	0.3 0.012	RNA4900.2RS	7.76 1740	8.06 1810	14000	0.0199	0.019 0.042
16 0.6299	16 0.6299	24 0.9449	13 0.512	0.3 0.012	RNA4901RS	8.64 1940	9.59 2160	12000	0.0219	0.021 0.046
	16 0.6299	24 0.9449	13 0.512	0.3 0.012	RNA4901.2RS	8.64 1940	9.59 2160	12000	0.0219	0.021 0.046
20 0.7874	20 0.7874	28 1.1024	13 0.512	0.3 0.012	RNA4902RS	9.70 2180	12.0 2700	9700	0.0254	0.026 0.057
	20 0.7874	28 1.1024	13 0.512	0.3 0.012	RNA4902.2RS	9.70 2180	12.0 2700	9700	0.0254	0.026 0.057
22 0.8661	22 0.8661	30 1.1811	13 0.512	0.3 0.012	RNA4903RS	10.1 2270	12.8 2880	8800	0.0269	0.027 0.060
	22 0.8661	30 1.1811	13 0.512	0.3 0.012	RNA4903.2RS	10.1 2270	12.8 2880	8800	0.0269	0.027 0.060
25 0.9843	25 0.9843	37 1.4567	17 0.669	0.3 0.012	RNA4904RS	18.5 4160	21.2 4770	7800	0.0318	0.062 0.137
	25 0.9843	37 1.4567	17 0.669	0.3 0.012	RNA4904.2RS	18.5 4160	21.2 4770	7800	0.0318	0.062 0.137
30 1.1811	30 1.1811	42 1.6535	17 0.669	0.3 0.012	RNA4905RS	21.0 4720	26.4 5930	6500	0.0362	0.075 0.165
	30 1.1811	42 1.6535	17 0.669	0.3 0.012	RNA4905.2RS	21.0 4720	26.4 5930	6500	0.0362	0.075 0.165
35 1.3780	35 1.3780	47 1.864	17 0.669	0.3 0.012	RNA4906RS	22.5 5060	30.0 6740	5500	0.0399	0.083 0.183
	35 1.3780	47 1.864	17 0.669	0.3 0.012	RNA4906.2RS	22.5 5060	30.0 6740	5500	0.0399	0.083 0.183
42 1.6535	42 1.6535	55 2.1654	20 0.787	0.6 0.024	RNA4907RS	29.1 6540	44.4 9980	4600	0.0454	0.130 0.287
	42 1.6535	55 2.1654	20 0.787	0.6 0.024	RNA4907.2RS	29.1 6540	44.4 9980	4600	0.0454	0.130 0.287
48 1.8898	48 1.8898	62 2.4409	22 0.866	0.6 0.024	RNA4908RS	38.6 8680	57.0 12800	4000	0.0519	0.163 0.359
	48 1.8898	62 2.4409	22 0.866	0.6 0.024	RNA4908.2RS	38.6 8680	57.0 12800	4000	0.0519	0.163 0.359
52 2.0472	52 2.0472	68 2.6772	22 0.866	0.6 0.024	RNA4909RS	39.4 8860	60.0 13500	3700	0.0550	0.207 0.456
	52 2.0472	68 2.6772	22 0.866	0.6 0.024	RNA4909.2RS	39.4 8860	60.0 13500	3700	0.0550	0.207 0.456
58 2.2835	58 2.2835	72 2.8346	22 0.866	0.6 0.024	RNA4910RS	41.2 9260	65.8 14800	3300	0.0591	0.187 0.412
	58 2.2835	72 2.8346	22 0.866	0.6 0.024	RNA4910.2RS	41.2 9260	65.8 14800	3300	0.0591	0.187 0.412



NEEDLE ROLLER BEARINGS
WITHOUT FLANGES
WITH INNER RINGS

METRIC SERIES

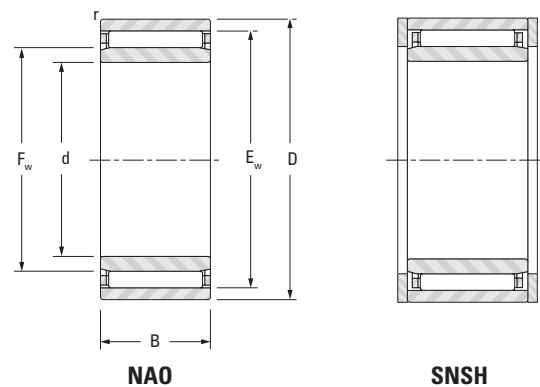

Shaft Dia.	d	D	B	F _w	E _w	r _{s min}	s ⁽¹⁾	Bearing Designation	End Washer Designation	Load Ratings		Speed Rating		C _g	Approx. Wt.
										Dynamic	Static	Oil	Grease		
										C	C ₀	min ⁻¹			
mm in	mm in	mm in	mm in	mm in	mm in	mm in	mm in			kN lbf				kg lbs	
6 0.2362	6 0.2362	17 0.6693	10 0.394	10 0.3937	13 0.5118	0.3 0.012	0.5 0.020	NAO6X17X10	SNSH10,5X17X0,5	5.40 1210	6.43 1450	39000	25000	0.0174	0.014 0.031
	8 0.3150	19 0.7480	10 0.394	12 0.4724	15 0.5906	0.3 0.012	0.5 0.020	NAO8X19X10	SNSH12,5X19X0,5	5.85 1320	7.51 1690	37000	24000	0.0195	0.017 0.037
10 0.3937	10 0.3937	22 0.8661	13 0.512	14 0.7087	18 0.7087	0.3 0.012	1.0 0.039	NAO10X22X13	SNSH14,5X22X0,5	9.73 2190	12.5 2810	29000	19000	0.0227	0.026 0.057
	10 0.3937	22 0.8661	20 0.787	14 0.5512	18 0.7087	0.3 0.012	0.5 0.020	NAO10X22X20	SNSH14,5X22X0,5	12.3 2770	16.8 3780	29000	19000	0.0291	0.041 0.090
	10 0.3937	26 1.0236	12 0.472	14 0.5512	20 0.7874	0.3 0.012	0.7 0.028	NAO10X26X12	SNSH14,5X26X0,5	10.5 2360	10.6 2380	21000	14000	0.0209	0.036 0.079
12 0.4724	12 0.4724	24 0.9449	13 0.512	16 0.6299	20 0.7874	0.3 0.012	1.0 0.039	NAO12X24X13	SNSH16,5X24X0,5	10.1 2270	13.5 3030	28000	18000	0.0245	0.030 0.066
	12 0.4724	24 0.9449	20 0.787	16 0.6299	20 0.7874	0.3 0.012	0.5 0.020	NAO12X24X20	SNSH16,5X24X0,5	13.4 3010	19.5 4380	28000	18000	0.0319	0.046 0.101
	12 0.4724	28 1.1024	12 0.472	16 0.6299	22 0.8661	0.3 0.012	0.7 0.028	NAO12X28X12	SNSH16,5X28X0,5	11.2 2520	11.9 2680	29000	19000	0.0227	0.041 0.090
15 0.5906	15 0.5906	28 1.1024	13 0.512	20 0.7874	24 0.9449	0.3 0.012	1.0 0.039	NAO15X28X13	SNSH20,5X28X0,5	11.5 2590	17.3 3890	22000	14000	0.0287	0.039 0.086
	15 0.5906	28 1.1024	26 1.024	20 0.7874	24 0.9449	0.3 0.012	1.0 0.039	NAO15X28X26	SNSH20,5X28X0,5	19.8 4450	34.6 7780	22000	14000	0.0405	0.078 0.172
	15 0.5906	32 1.2598	12 0.472	20 0.7874	26 1.0236	0.3 0.012	0.7 0.028	NAO15X32X12	SNSH20,5X32X0,5	13.0 2920	15.0 3370	23000	15000	0.0264	0.050 0.110
17 0.6693	17 0.6693	30 1.1811	13 0.512	22 0.8661	26 1.0236	0.3 0.012	1.0 0.039	NAO17X30X13	SNSH22,5X30X0,5	11.8 2650	18.3 4110	20000	13000	0.0303	0.043 0.095
	17 0.6693	30 1.1811	26 1.024	22 0.8661	26 1.0236	0.3 0.012	1.0 0.039	NAO17X30X26	SNSH22,5X30X0,5	20.2 4540	36.6 8230	20000	13000	0.0428	0.084 0.185
	17 0.6693	35 1.3780	16 0.630	22 0.8661	29 1.1417	0.3 0.012	1.5 0.059	NAO17X35X16	SNSH22,5X35X0,5	19.0 4270	23.3 5240	20000	13000	0.0299	0.078 0.172
	17 0.6693	35 1.3780	32 1.260	22 0.8661	29 1.1417	0.3 0.012	1.5 0.059	NAO17X35X32	SNSH22,5X35X0,5	32.7 7350	46.5 10500	20000	13000	0.0423	0.154 0.340
20 0.7874	20 0.7874	35 1.3780	17 0.669	25 0.9843	30 1.1811	0.3 0.012	1.2 0.047	NAO20X35X17	SNSH25,5X35X0,5	18.8 4230	29.8 6700	17000	11000	0.0351	0.073 0.161
	20 0.7874	35 1.3780	26 1.024	25 0.9843	30 1.1811	0.3 0.012	1.2 0.047	NAO20X35X26	SNSH25,5X35X0,5	25.0 5620	42.8 9620	17000	11000	0.0456	0.112 0.247
	20 0.7874	37 1.4567	16 0.630	25 0.9843	32 1.2598	0.3 0.012	1.5 0.059	NAO20X37X16	SNSH25,5X37X0,5	19.8 4450	25.3 5690	17000	11000	0.0323	0.080 0.176

⁽¹⁾ Max. axial displacement.

Continued on next page.

Shaft Dia.	d	D	B	F _w	E _w	r _{s min}	s ⁽¹⁾	Bearing Designation	End Washer Designation	Load Ratings		Speed Rating		C _g	Approx. Wt.
										Dynamic	Static	Oil	Grease		
										C	C ₀	min ⁻¹			
mm in	mm in	mm in	mm in	mm in	mm in	mm in	mm in			kN lbf				kg lbs	
20 0.7874	20 0.7874	37 1.4567	32 1.260	25 0.9843	32 1.2598	0.3 0.012	1.5 0.059	NAO20X37X32	SNSH25,5X37X0,5	34.0 7640	50.7 11400	17000	11000	0.0455	0.162 0.357
25 0.9843	25 0.9843	40 1.5748	17 0.669	30 1.1811	35 1.3780	0.3 0.012	1.2 0.047	NAO25X40X17	SNSH30,5X40X0,5	20.2 4540	34.9 7850	14000	9300	0.0394	0.088 0.194
	25 0.9843	40 1.5748	26 1.024	30 1.1811	35 1.3780	0.3 0.012	1.2 0.047	NAO25X40X26	SNSH30,5X40X0,5	26.8 6020	49.7 11200	14000	9300	0.0512	0.132 0.291
	25 0.9843	42 1.6535	16 0.630	30 1.1811	37 1.4567	0.3 0.012	1.5 0.059	NAO25X42X16		22.4 5040	31.0 6970	15000	9600	0.0366	0.096 0.212
	25 0.9843	42 1.6535	32 1.260	30 1.1811	37 1.4567	0.3 0.012	1.5 0.059	NAO25X42X32		38.2 8590	62.1 14000	15000	9600	0.0517	0.185 0.408
30 1.1811	30 1.1811	45 1.7717	17 0.669	35 1.3780	40 1.5748	0.3 0.012	1.2 0.047	NAO30X45X17		22.1 4970	40.8 9170	12000	7900	0.0440	0.102 0.225
	30 1.1811	45 1.7717	26 1.024	35 1.3780	40 1.5748	0.3 0.012	1.2 0.047	NAO30X45X26		27.7 6230	54.5 12300	12000	7900	0.0561	0.155 0.342
	30 1.1811	47 1.8504	16 0.630	35 1.3780	42 1.6535	0.3 0.012	1.5 0.059	NAO30X47X16	SNSH35,5X47X0,5	24.5 5510	36.8 8270	12000	8100	0.0408	0.106 0.234
	30 1.1811	47 1.8504	32 1.260	35 1.3780	42 1.6535	0.3 0.012	1.5 0.059	NAO30X47X32	SNSH35,5X47X0,5	42.0 9440	73.5 16500	12000	8100	0.0576	0.218 0.481
35 1.3780	35 1.3780	50 1.9685	17 0.669	40 1.5748	45 1.7717	0.3 0.012	1.2 0.047	NAO35X50X17		23.8 5350	47.0 10600	11000	6900	0.0484	0.126 0.278
	35 1.3780	50 1.9685	34 1.339	40 1.5748	45 1.7717	0.3 0.012	0.7 0.028	NAO35X50X34	SNSH40,5X50X0,5	40.9 9190	94.1 21200	11000	6900	0.0682	0.232 0.511
	35 1.3780	55 2.1654	20 0.787	40 1.5748	48 1.8898	0.3 0.012	1.5 0.059	NAO35X55X20	SNSH41X55X1	35.5 7980	56.3 12700	11000	7100	0.0472	0.185 0.408
	35 1.3780	55 2.1654	40 1.575	40 1.5748	48 1.8898	0.3 0.012	1.7 0.067	NAO35X55X40		60.8 13700	113 25400	11000	7100	0.0666	0.370 0.816
40 1.5748	40 1.5748	55 2.1654	17 0.669	45 1.7717	50 1.9685	0.3 0.012	0.7 0.028	NAO40X55X17	SNSH45,5X55X0,5	24.9 5600	51.8 11600	9400	6100	0.0523	0.133 0.293
	40 1.5748	55 2.1654	34 1.339	45 1.7717	50 1.9685	0.3 0.012	0.7 0.028	NAO40X55X34	SNSH45,5X55X0,5	42.7 9600	104 23400	9400	6100	0.0737	0.257 0.567
	40 1.5748	62 2.4409	20 0.787	45 1.7717	53 2.0866	0.3 0.012	1.5 0.059	NAO40X62X20	SNSH46X62X1	36.0 8090	59.5 13400	9600	6200	0.0504	0.215 0.474
	40 1.5748	62 2.4409	40 1.575	45 1.7717	53 2.0866	0.3 0.012	1.7 0.067	NAO40X62X40	SNSH46X62X1	61.7 13900	119 26800	9600	6200	0.0711	0.440 0.970
45 1.7717	45 1.7717	62 2.4409	20 0.787	50 1.9685	55 2.1654	0.3 0.012	0.7 0.028	NAO45X62X20		30.2 6790	68.5 15400	8400	5400	0.0588	0.200 0.441
	45 1.7717	62 2.4409	40 1.575	50 1.9685	55 2.1654	0.3 0.012	0.5 0.020	NAO45X62X40		50.7 11400	137 30800	8400	5400	0.0829	0.386 0.851
	45 1.7717	72 2.8346	20 0.787	55 2.1654	63 2.4803	1.0 0.039	1.5 0.059	NAO45X72X20	SNSH56X72X1	40.3 9060	73.5 16500	7800	5000	0.0580	0.345 0.761
	45 1.7717	72 2.8346	40 1.575	55 2.1654	63 2.4803	1.0 0.039	1.7 0.067	NAO45X72X40	SNSH56X72X1	69.1 15500	147 33000	7800	5000	0.0818	0.680 1.499
50 1.9685	50 1.9685	68 2.6772	20 0.787	55 2.1654	60 2.3622	0.3 0.012	0.7 0.028	NAO50X68X20		30.7 6900	72.4 16300	7600	4900	0.0622	0.230 0.507
	50 1.9685	68 2.6772	40 1.575	55 2.1654	60 2.3622	0.3 0.012	0.5 0.020	NAO50X68X40		52.7 11800	145 32600	7600	4900	0.0878	0.450 0.992
	50 1.9685	78 3.0709	20 0.787	60 2.3622	68 2.6772	1.0 0.039	1.5 0.059	NAO50X78X20	SNSH61X78X1	41.8 9400	79.2 17800	7100	4600	0.0614	0.385 0.849

⁽¹⁾ Max. axial displacement.

Continued on next page.



NEEDLE ROLLER BEARINGS
WITHOUT FLANGES
WITH INNER RINGS — continued

METRIC SERIES

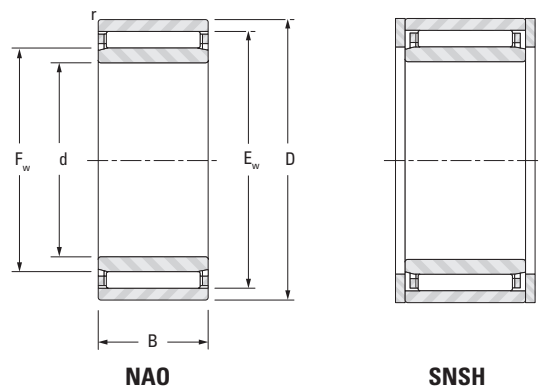

Shaft Dia.	d	D	B	F _w	E _w	r _{s min}	s ⁽¹⁾	Bearing Designation	End Washer Designation	Load Ratings		Speed Rating		C _g	Approx. Wt.
										Dynamic	Static	Oil	Grease		
										C	C ₀	min ⁻¹			
mm in	mm in	mm in	mm in	mm in	mm in	mm in	mm in			kN lbf		min ⁻¹		kg lbs	
50 1.9685	50 1.9685	78 3.0709	40 1.575	60 2.3622	68 2.6772	1.0 0.039	1.7 0.067	NA050X78X40	SNSH61X78X1	71.7 16100	158 35500	7100	4600	0.0867	0.746 1.645
55 2.1654	55 2.1654	85 3.3465	30 1.181	65 2.5591	73 2.8740	1.0 0.039	2.0 0.079	NA055X85X30	SNSH66X85X1	60.1 13500	129 29000	6500	4200	0.0719	0.690 1.521
55 2.1654	55 2.1654	85 3.3465	60 2.362	65 2.5591	73 2.8740	1.0 0.039	1.5 0.059	NA055X85X60	SNSH66X85X1	103 23200	259 58200	6500	4200	0.1015	1.320 2.910
60 2.3622	60 2.3622	90 3.5433	30 1.181	70 2.7559	78 3.0709	1.0 0.039	2.0 0.079	NA060X90X30		62.2 14000	139 31200	6000	3900	0.0757	0.745 1.642
	60 2.3622	90 3.5433	60 2.362	70 2.7559	78 3.0709	1.0 0.039	1.7 0.067	NA060X90X60		107 24100	277 62300	6000	3900	0.1068	1.405 3.097
65 2.5591	65 2.5591	95 3.7402	30 1.181	75 2.9528	83 3.2677	1.0 0.039	2.0 0.079	NA065X95X30		60.9 13700	138 31000	5600	3600	0.0780	0.770 1.698
	65 2.5591	95 3.7402	60 2.362	75 2.9528	83 3.2677	1.0 0.039	1.7 0.067	NA065X95X60		116 26100	277 62300	5600	3600	0.1101	1.500 3.307
70 2.7559	70 2.7559	100 3.9370	30 1.181	80 3.1496	88 3.4646	1.0 0.039	2.0 0.079	NA070X100X30		67.5 15200	161 36200	5200	3400	0.0835	0.850 1.874
	70 2.7559	100 3.9370	60 2.362	80 3.1496	88 3.4646	1.0 0.039	1.7 0.067	NA070X100X60		116 26100	322 72400	5200	3400	0.1178	1.600 3.527
80 3.1496	80 3.1496	110 4.3307	30 1.181	90 3.5433	98 3.8583	1.0 0.039	2.0 0.079	NA080X110X30		63.6 14300	155 34800	4600	3000	0.0873	0.920 2.028
85 3.3465	85 3.3465	115 4.5276	30 1.181	95 3.7402	103 4.0551	1.0 0.039	2.0 0.079	NA085X115X30		71.0 16000	183 41100	4400	2800	0.0932	0.985 2.172
90 3.5433	90 3.5433	120 4.7244	30 1.181	100 3.9370	108 4.2520	1.0 0.039	2.0 0.079	NA090X120X30		72.4 16300	191 42900	4200	2700	0.0965	1.010 2.22

⁽¹⁾ Max. axial displacement.

NEEDLE ROLLER BEARINGS
WITHOUT FLANGES
WITHOUT INNER RINGS

METRIC SERIES

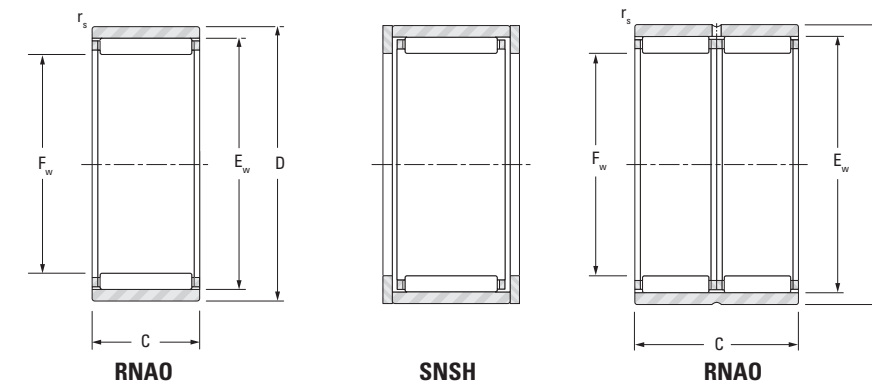

Shaft Dia.	F _w	D	C	E _w	r _{s min}	Bearing Designation	End Washer Designation	Load Ratings		Speed Rating		C _g	Approx. Wt.
								Dynamic	Static	Oil	Grease		
								C	C ₀	min ⁻¹			
mm in	mm in	mm in	mm in	mm in	mm in			kN lbf		min ⁻¹		kg lbs	
6 0.2362	6 0.2362	13 0.5118	8 0.315	9 0.3543	0.3 0.012	RNA06X13X8TN		2.47 560	2.07 470	44000	29000	0.0107	0.005 0.011
7 0.2756	7 0.2756	14 0.5512	8 0.315	10 0.3937	0.3 0.012	RNA07X14X8TN		2.74 620	2.44 550	42000	28000	0.0118	0.007 0.015
8 0.3150	8 0.3150	15 0.5906	10 0.394	11 0.4331	0.3 0.012	RNA08X15X10	SNSH8,5X15X0,5	4.57 1030	4.89 1100	41000	26000	0.0148	0.008 0.018
9 0.3543	9 0.3543	16 0.6299	10 0.394	12 0.4724	0.3 0.012	RNA09X16X10		4.27 960	4.60 1030	40000	26000	0.0153	0.009 0.020
10 0.3937	10 0.3937	17 0.6693	10 0.394	13 0.5118	0.3 0.012	RNA010X17X10	SNSH10,5X17X0,5	5.40 1210	6.43 1450	39000	25000	0.0174	0.010 0.022
	10 0.3937	17 0.6693	20 0.787	13 0.5118	0.3 0.012	RNA010X17X20	SNSH10,5X17X0,5	9.25 2080	12.9 2900	39000	25000	0.0245	0.019 0.042
12 0.4724	12 0.4724	19 0.7480	10 0.394	15 0.5906	0.3 0.012	RNA012X19X10	SNSH12,5X19X0,5	5.85 1320	7.51 1690	37000	24000	0.0195	0.012 0.026
14 0.5512	14 0.5512	22 0.8661	13 0.512	18 0.7087	0.3 0.012	RNA014X22X13	SNSH14,5X22X0,5	9.73 2190	12.5 2810	29000	19000	0.0227	0.018 0.040
	14 0.5512	22 0.8661	20 0.787	18 0.7087	0.3 0.012	RNA014X22X20	SNSH14,5X22X0,5	12.3 2770	16.8 3780	29000	19000	0.0291	0.029 0.064
	14 0.5512	26 1.0236	12 0.472	20 0.7874	0.3 0.012	RNA014X26X12	SNSH14,5X26X0,5	10.5 2360	10.6 2380	21000	14000	0.0209	0.029 0.064
15 0.5906	15 0.5906	23 0.9055	13 0.512	19 0.7480	0.3 0.012	RNA015X23X13	SNSH15,5X23X0,5	9.66 2170	12.6 2830	28000	18000	0.0235	0.019 0.042
	15 0.5906	23 0.9055	20 0.787	19 0.7480	0.3 0.012	RNA015X23X20	SNSH15,5X23X0,5	13.5 3030	19.4 4360	28000	18000	0.0310	0.029 0.064
16 0.6299	16 0.6299	24 0.9449	13 0.512	20 0.7874	0.3 0.012	RNA016X24X13	SNSH16,5X24X0,5	10.1 2270	13.5 3030	28000	18000	0.0245	0.022 0.049
	16 0.6299	24 0.9449	20 0.787	20 0.7874	0.3 0.012	RNA016X24X20	SNSH16,5X24X0,5	13.4 3010	19.5 4380	28000	18000	0.0319	0.032 0.071
	16 0.6299	28 1.1024	12 0.472	22 0.8661	0.3 0.012	RNA016X28X12	SNSH16,5X28X0,5	11.2 2520	11.9 2680	29000	19000	0.0227	0.033 0.073
17 0.6693	17 0.6693	25 0.9843	13 0.512	21 0.8268	0.3 0.012	RNA017X25X13	SNSH17,5X25X0,5	10.5 2360	14.5 3260	26000	17000	0.0256	0.022 0.049
	17 0.6693	25 0.9843	20 0.787	21 0.8268	0.3 0.012	RNA017X25X20	SNSH17,5X25X0,5	14.7 3300	22.5 5060	26000	17000	0.0333	0.032 0.071
18 0.7087	18 0.7087	26 1.0236	13 0.512	22 0.8661	0.3 0.012	RNA018X26X13	SNSH18,5X26X0,5	10.8 2430	15.4 3460	24000	16000	0.0266	0.024 0.053
	18 0.7087	26 1.0236	13 0.512	22 0.8661	0.3 0.012	RNA018X26X13ASR1	SNSH18,5X26X0,5	10.8 2430	15.4 3460	24000	16000	0.0266	0.024 0.053
	18 0.7087	26 1.0236	20 0.787	22 0.8661	0.3 0.012	RNA018X26X20	SNSH18,5X26X0,5	14.4 3240	22.2 4990	24000	16000	0.0347	0.034 0.075
	18 0.7087	30 1.1811	24 0.945	24 0.9449	0.3 0.012	RNA018X30X24		20.2 4540	26.2 5890	25000	17000	0.0343	0.070 0.154
20 0.7874	20 0.7874	28 1.1024	13 0.512	24 0.9449	0.3 0.012	RNA020X28X13	SNSH20,5X28X0,5	11.5 2590	17.3 3890	22000	14000	0.0287	0.025 0.055

Continued on next page.



NEEDLE ROLLER BEARINGS

NEEDLE ROLLER BEARINGS WITHOUT FLANGES WITHOUT INNER RINGS

— continued

METRIC SERIES

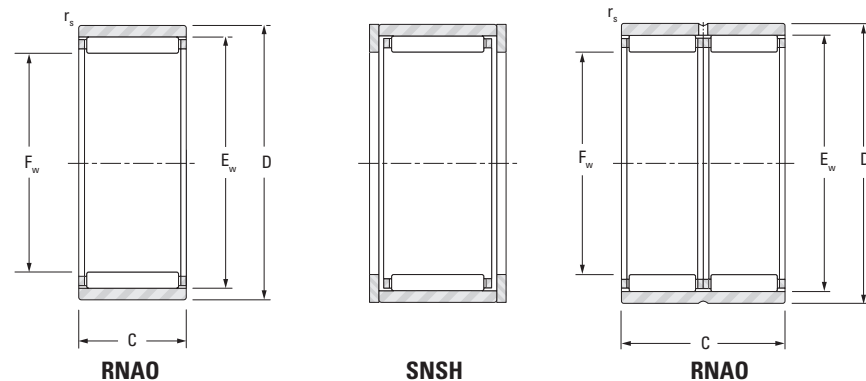

Shaft Dia. mm in	F _w mm in	D mm in	C mm in	E _w mm in	r _{s min} mm in	Bearing Designation	End Washer Designation	Load Ratings		Speed Rating		C _g	Approx. Wt. kg lbs
								Dynamic	Static	Oil	Grease		
								C	C ₀	min ⁻¹			
20 0.7874	20 0.7874	28 1.1024	26 1.024	24 0.9449	0.3 0.012	RNA020X28X26	SNSH20,5X28X0,5	19.8 4450	34.6 7780	22000	14000	0.0405	0.050 0.110
	20 0.7874	32 1.2598	12 0.472	26 1.0236	0.3 0.012	RNA020X32X12	SNSH20,5X32X0,5	13.0 2920	15.3 3440	23000	15000	0.0264	0.038 0.084
	20 0.7874	32 1.2598	24 0.945	26 1.0236	0.3 0.012	RNA020X32X24	SNSH20,5X32X0,5	22.3 5010	30.6 6880	23000	15000	0.0373	0.080 0.176
22 0.8661	22 0.8661	30 1.1811	13 0.512	26 1.0236	0.3 0.012	RNA022X30X13	SNSH22,5X30X0,5	11.8 2650	18.3 4110	20000	13000	0.0303	0.028 0.062
	22 0.8661	30 1.1811	26 1.024	26 1.0236	0.3 0.012	RNA022X30X26	SNSH22,5X30X0,5	20.2 4540	36.6 8230	20000	13000	0.0428	0.053 0.117
	22 0.8661	35 1.3780	16 0.630	29 1.1417	0.3 0.012	RNA022X35X16	SNSH22,5X35X0,5	19.1 4290	23.3 5240	21000	13000	0.0299	0.059 0.130
	22 0.8661	35 1.3780	32 1.260	29 1.1417	0.3 0.012	RNA022X35X32	SNSH22,5X35X0,5	32.7 7350	46.5 10500	21000	13000	0.0423	0.116 0.256
25 0.9843	25 0.9843	35 1.3780	17 0.669	30 1.1811	0.3 0.012	RNA025X35X17	SNSH25,5X35X0,5	18.8 4230	29.8 6700	17000	11000	0.0351	0.050 0.110
	25 0.9843	35 1.3780	26 1.024	30 1.1811	0.3 0.012	RNA025X35X26	SNSH25,5X35X0,5	25.0 5620	42.8 9620	17000	11000	0.0456	0.076 0.168
	25 0.9843	37 1.4567	16 0.630	32 1.2598	0.3 0.012	RNA025X37X16	SNSH25,5X37X0,5	19.8 4450	25.3 5690	18000	12000	0.0323	0.058 0.128
	25 0.9843	37 1.4567	32 1.260	32 1.2598	0.3 0.012	RNA025X37X32	SNSH25,5X37X0,5	19.2 4320	23.6 5310	18000	12000	0.0455	0.118 0.260
28 1.1024	28 1.1024	40 1.5748	16 0.630	35 1.3780	0.3 0.012	RNA028X40X16	SNSH28,5X40X0,5	20.9 4700	27.9 6270	16000	10000	0.0347	0.063 0.139
	28 1.1024	40 1.5748	32 1.260	35 1.3780	0.3 0.012	RNA028X40X32	SNSH28,5X40X0,5	35.8 8050	55.9 12600	16000	10000	0.0489	0.128 0.282
30 1.1811	30 1.1811	40 1.5748	17 0.669	35 1.3780	0.3 0.012	RNA030X40X17	SNSH30,5X40X0,5	20.2 4540	34.6 7780	14000	9300	0.0394	0.060 0.132
	30 1.1811	40 1.5748	26 1.024	35 1.3780	0.3 0.012	RNA030X40X26	SNSH30,5X40X0,5	26.8 6020	49.7 11200	14000	9300	0.0512	0.088 0.194
	30 1.1811	42 1.6535	16 0.630	37 1.4567	0.3 0.012	RNA030X42X16		22.3 5010	31.0 6970	15000	9600	0.0366	0.069 0.152
	30 1.1811	42 1.6535	32 1.260	37 1.4567	0.3 0.012	RNA030X42X32		38.2 8590	62.1 14000	15000	9600	0.0517	0.131 0.289
35 1.3780	35 1.3780	45 1.7717	17 0.669	40 1.5748	0.3 0.012	RNA035X45X17		22.1 4970	40.8 9170	12000	7900	0.0440	0.069 0.152
	35 1.3780	45 1.7717	26 1.024	40 1.5748	0.3 0.012	RNA035X45X26		27.7 6230	54.5 12300	12000	7900	0.0561	0.091 0.201
	35 1.3780	47 1.8504	16 0.630	41 1.6142	0.3 0.012	RNA035X47X16	SNSH35,5X47X0,5	24.5 5510	36.8 8270	12000	8100	0.0404	0.075 0.165
	35 1.3780	47 1.8504	32 1.260	42 1.6535	0.3 0.012	RNA035X47X32	SNSH35,5X47X0,5	42.0 9440	73.5 16500	12000	8100	0.0576	0.156 0.344
40 1.5748	40 1.5748	50 1.9685	17 0.669	45 1.7717	0.3 0.012	RNA040X50X17	SNSH40,5X50X0,5	23.8 5350	47.0 10600	11000	6900	0.0484	0.086 0.190

Continued on next page.

Heavy-Duty Needle Roller Bearings

Shaft Dia. mm in	F _w mm in	D mm in	C mm in	E _w mm in	r _{s min} mm in	Bearing Designation	End Washer Designation	Load Ratings		Speed Rating		C _g	Approx. Wt. kg lbs
								Dynamic	Static	Oil	Grease		
								C	C ₀	min ⁻¹			
40 1.5748	40 1.5748	50 1.9685	34 1.339	45 1.7717	0.3 0.012	RNA040X50X34	SNSH40,5X50X0,5	40.9 9190	94.1 21200	11000	6900	0.0575	0.152 0.335
	40 1.5748	55 2.1654	20 0.787	48 1.8898	0.3 0.012	RNA040X55X20	SNSH41X55X1	35.5 7980	56.3 12700	11000	7100	0.0472	0.139 0.306
	40 1.5748	55 2.1654	40 1.575	48 1.8898	0.3 0.012	RNA040X55X40	SNSH41X55X1	60.8 13700	113 25400	11000	7100	0.0666	0.276 0.608
45 1.7717	45 1.7717	55 2.1654	17 0.669	50 1.9685	0.3 0.012	RNA045X55X17	SNSH45,5X55X0,5	24.9 5600	51.8 11600	9400	6100	0.0523	0.089 0.196
	45 1.7717	55 2.1654	34 1.339	50 1.9685	0.3 0.012	RNA045X55X34	SNSH45,5X55X0,5	42.7 9600	104 23400	9400	6100	0.0737	0.168 0.370
	45 1.7717	62 2.4409	20 0.787	53 2.0866	0.3 0.012	RNA045X62X20	SNSH46X62X1	30.8 6920	68.1 15300	9400	6100	0.0504	0.163 0.359
	45 1.7717	62 2.4409	40 1.575	53 2.0866	0.3 0.012	RNA045X62X40	SNSH46X62X1	61.7 13900	119 26800	9600	6200	0.0711	0.325 0.717
50 1.9685	50 1.9685	62 2.4409	20 0.787	55 2.1654	0.3 0.012	RNA050X62X20		30.2 6790	68.5 15400	8400	5400	0.0588	0.142 0.313
	50 1.9685	62 2.4409	40 1.575	55 2.1654	0.3 0.012	RNA050X62X40		51.7 11600	137 30800	8400	5400	0.0829	0.269 0.593
	50 1.9685	65 2.5591	20 0.787	58 2.2835	0.3 0.012	RNA050X65X20	SNSH51X65X1	38.8 8720	67.8 15200	8600	5600	0.0545	0.167 0.368
	50 1.9685	65 2.5591	40 1.575	58 2.2835	0.3 0.012	RNA050X65X40		66.5 14900	136 30600	8600	5600	0.0769	0.342 0.754
55 2.1654	55 2.1654	68 2.6772	20 0.787	60 2.3622	0.3 0.012	RNA055X68X20		30.7 6900	72.4 16300	7600	4900	0.0622	0.165 0.364
	55 2.1654	68 2.6772	40 1.575	60 2.3622	0.3 0.012	RNA055X68X40		52.7 11800	145 32600	7600	4900	0.0878	0.320 0.705
	55 2.1654	72 2.8346	20 0.787	63 2.4803	1.0 0.039	RNA055X72X20	SNSH56X72X1	40.3 9060	73.5 16500	7800	5000	0.0580	0.212 0.467
	55 2.1654	72 2.8346	40 1.575	63 2.4803	1.0 0.039	RNA055X72X40	SNSH56X72X1	69.1 15500	127 28600	7800	5000	0.0818	0.433 0.955
60 2.3622	60 2.3622	78 3.0709	20 0.787	68 2.6772	1.0 0.039	RNA060X78X20	SNSH61X78X1	41.8 9400	79.2 17800	7100	4600	0.0614	0.230 0.507
	60 2.3622	78 3.0709	40 1.575	68 2.6772	1.0 0.039	RNA060X78X40	SNSH61X78X1	71.7 16100	158 35500	7100	4600	0.0867	0.436 0.961
65 2.5591	65 2.5591	85 3.3465	30 1.181	73 2.8740	1.0 0.039	RNA065X85X30	SNSH66X85X1	60.1 13500	129 29000	6500	4200	0.0719	0.468 1.032
	65 2.5591	85 3.3465	60 2.362	73 2.8740	1.0 0.039	RNA065X85X60	SNSH66X85X1	103 23200	259 58200	6500	4200	0.1015	0.876 1.931
70 2.7559	70 2.7559	90 3.5433	30 1.181	78 3.0709	1.0 0.039	RNA070X90X30		62.2 14000	139 31200	6000	3900	0.0757	0.505 1.113
	70 2.7559	90 3.5433	60 2.362	78 3.0709	1.0 0.039	RNA070X90X60		107 24100	277 62300	6000	3900	0.1068	0.925 2.039
75 2.9528	75 2.9528	95 3.7402	30 1.181	83 3.2677	1.0 0.039	RNA075X95X30		60.9 13700	138 31000	5600	3600	0.0780	0.510 1.124
	75 2.9528	95 3.7402	60 2.362	83 3.2677	1.0 0.039	RNA075X95X60		104 23400	277 62300	5600	3600	0.1101	0.980 2.161
80 3.1496	80 3.1496	100 3.9370	30 1.181	88 3.4646	1.0 0.039	RNA080X100X30		67.5 15200	161 36200	5200	3400	0.0835	0.580 1.279
	80 3.1496	100 3.9370	60 2.362	88 3.4646	1.0 0.039	RNA080X100X60		116 26100	322 72400	5200	3400	0.1178	1.044 2.30
85 3.3465	85 3.3465	105 4.1339	30 1.181	93 3.6614	1.0 0.039	RNA085X105X30		69.4 15600	170 38200	4600	3000	0.0870	0.586 1.292
100 3.9370	100 3.9370	120 4.7244	30 1.181	108 4.2520	1.0 0.039	RNA100X120X30		72.4 16300	191 42900	4200	2700	0.0965	0.660 1.455



NEEDLE ROLLER BEARINGS
FULL COMPLEMENT
WITHOUT INNER RINGS

METRIC SERIES

- Check for availability.

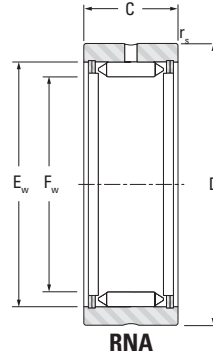

Shaft Dia.	F _w	D	C	E _w	r _{s min}	Bearing Designation	Load Ratings		Speed Rating		C _g	Approx. Wt.
							Dynamic	Static	Oil	Grease		
							C	C ₀				
mm in	mm in	mm in	mm in	mm in	mm in		kN lbf	min ⁻¹			kg lbs	
7.3 0.2874	7.3 0.2874	16 0.6299	12 0.472	12.3 0.4843	0.35 0.014	RNA 1005	3.95 888	4.45 1000	52000	34000	0.0134	0.010 0.022
9.7 0.3819	9.7 0.3819	19 0.7480	12 0.472	14.7 0.5787	0.35 0.014	RNA 1007	4.80 1080	5.90 1330	39000	25000	0.0160	0.013 0.029
12.1 0.4764	12.1 0.4764	22 0.8661	12 0.472	17.1 0.6732	0.35 0.014	RNA 1009	5.60 1260	7.40 1660	31000	20000	0.0184	0.018 0.040
14.4 0.5669	14.4 0.5669	24 0.9449	12 0.472	19.4 0.7638	0.35 0.014	RNA 1010	6.35 1430	8.90 2000	26000	17000	0.0206	0.020 0.044
17.6 0.6929	17.6 0.6929	28 1.1024	15 0.591	22.6 0.8898	0.35 0.014	RNA 1012	11.0 2470	16.5 3710	22000	14000	0.0261	0.034 0.075
20.8 0.8189	20.8 0.8189	32 1.2598	15 0.591	25.8 1.0157	0.65 0.026	RNA 1015	12.4 2790	19.5 4380	18000	12000	0.0292	0.044 0.097
22.1 0.8701	22.1 0.8701	35 1.3780	22 0.866	28.1 1.1063	0.65 0.026	RNA 2015	23.5 5280	37.5 8430	17000	11000	0.0345	0.082 0.181
23.9 0.9409	23.9 0.9409	35 1.3780	15 0.591	28.9 1.1378	0.65 0.026	RNA 1017	13.7 3080	22.5 5060	16000	10000	0.0321	0.047 0.104
28.7 1.1299	28.7 1.1299	42 1.6535	18 0.709	34.7 1.3661	0.65 0.026	RNA 1020	19.3 4340	33.5 7530	13000	8600	0.0374	0.084 0.185
	28.7 1.1299	42 1.6535	22 0.866	34.7 1.3661	0.65 0.026	RNA 2020	28.5 6410	49.0 11000	13000	8600	0.0411	0.104 0.229
33.5 1.3189	33.5 1.3189	47 1.8504	18 0.709	39.5 1.5551	0.65 0.026	RNA 1025	21.5 4830	39.0 8770	11000	7200	0.0415	0.097 0.214
	33.5 1.3189	47 1.8504	22 0.866	39.5 1.5551	0.65 0.026	RNA 2025	33.0 7420	60.0 13500	11000	7200	0.0457	0.122 0.269
	33.5 1.3189	47 1.8504	30 1.181	39.5 1.5551	0.65 0.026	RNA 22025	52.0 11700	94.0 21100	11000	7200	0.0537	0.170 0.375
38.2 1.5039	38.2 1.5039	52 2.0472	18 0.709	44.2 1.7402	0.65 0.026	RNA 1030	23.5 5280	44.5 10000	10000	6500	0.0455	0.107 0.236
	38.2 1.5039	52 2.0472	22 0.866	44.2 1.7402	0.65 0.026	RNA 2030	34.5 7760	66.0 14800	10000	6500	0.0501	0.139 0.306
	38.2 1.5039	52 2.0472	30 1.181	44.2 1.7402	0.65 0.026	RNA 22030	57.0 12800	108 24300	10000	6500	0.0588	0.193 0.425
44 1.7323	44 1.7323	58 2.2835	18 0.709	50.0 1.9685	0.65 0.026	RNA 1035	26.0 5850	51.0 11500	8600	5600	0.0552	0.127 0.280
	44 1.7323	58 2.2835	22 0.866	50.0 1.9685	0.65 0.026	RNA 2035	38.0 8540	75.0 16900	8600	5600	0.0552	0.160 0.353
	44 1.7323	58 2.2835	30 1.181	50.0 1.9685	0.65 0.026	RNA 22035	63.0 14200	124 27900	8600	5600	0.0686	0.225 0.496

Continued on next page.

Shaft Dia.	F _w	D	C	E _w	r _{s min}	Bearing Designation	Load Ratings		Speed Rating		C _g	Approx. Wt.
							Dynamic	Static	Oil	Grease		
							C	C ₀				
mm in	mm in	mm in	mm in	mm in	mm in		kN lbf	min ⁻¹			kg lbs	
44 1.7323	44 1.7323	62 2.4409	30 1.181	51.0 2.0094	0.65 0.026	RNA 3030	64.0 14400	125 28100	8600	5600	0.0607	0.309 0.681
49.7 1.9567	49.7 1.9567	65 2.5591	18 0.709	55.7 2.1929	0.85 0.033	RNA 1040	28.5 6410	58.0 13000	7600	4900	0.0546	0.160 0.353
	49.7 1.9567	65 2.5591	22 0.866	55.7 2.1929	0.65 0.026	RNA 2040	41.5 9330	85.0 19100	7600	4900	0.0601	0.200 0.441
	49.7 1.9567	65 2.5591	30 1.181	55.7 2.1929	0.65 0.026	RNA 22040	68.0 15300	140 31500	7600	4900	0.0707	0.278 0.613
	49.7 1.9567	72 2.8346	36 1.417	56.8 2.2346	0.65 0.026	RNA 3035	90.0 20200	183 41100	7600	4900	0.0704	0.545 1.202
55.4 2.1811	55.4 2.1811	72 2.8346	18 0.709	61.4 2.4173	0.85 0.033	RNA 1045	30.5 6860	65.0 14600	6900	4500	0.0590	0.193 0.425
	55.4 2.1811	72 2.8346	22 0.866	61.4 2.4173	0.85 0.033	RNA 2045	45.0 10100	95.0 21400	6900	4500	0.0649	0.242 0.534
	55.4 2.1811	80 3.1496	36 1.417	62.5 2.4591	0.85 0.033	RNA 3040	97.0 21800	204 45900	6900	4500	0.0759	0.672 1.482
62.1 2.4449	62.1 2.4449	80 3.1496	20 0.787	68.1 2.6811	0.85 0.033	RNA 1050	33.0 7420	73.0 16400	6100	4000	0.0639	0.255 0.562
	62.1 2.4449	80 3.1496	28 1.102	68.1 2.6811	0.85 0.033	RNA 2050	64.0 14400	142 31900	6100	4000	0.0754	0.375 0.827
	62.1 2.4449	85 3.3465	38 1.496	69.2 2.7228	0.85 0.033	RNA 3045	105 23600	230 51700	6100	4000	0.0823	0.710 1.565
68.8 2.7087	68.8 2.7087	85 3.3465	20 0.787	74.8 2.9449	0.85 0.033	RNA 1055	35.5 7980	80.0 18000	5500	3600	0.0687	0.258 0.569
	68.8 2.7087	85 3.3465	28 1.102	74.8 2.9449	0.85 0.033	RNA 2055	69.0 15500	157 35300	5500	3600	0.0810	0.361 0.796
	68.8 2.7087	90 3.5433	38 1.496	75.9 2.9866	0.85 0.033	RNA 3050	113 25400	255 57300	5500	3600	0.0885	0.705 1.55
72.6 2.8583	72.6 2.8583	90 3.5433	20 0.787	78.6 3.0945	0.85 0.033	RNA 1060	37.0 8320	85.0 19100	5200	3400	0.0714	0.283 0.624
	72.6 2.8583	90 3.5433	28 1.102	78.6 3.0945	0.85 0.033	RNA 2060	72.0 16200	165 37100	5200	3400	0.0842	0.413 0.911
	72.6 2.8583	95 3.7402	38 1.496	79.6 3.1339	0.85 0.033	RNA 3055	117 26300	268 60200	5200	3400	0.0811	0.782 1.724
78.3 3.0827	78.3 3.0827	95 3.7402	20 0.787	84.3 3.3189	0.85 0.033	RNA 1065	41.5 9330	97.0 21800	4900	3200	0.0751	0.306 0.675
	78.3 3.0827	95 3.7402	28 1.102	84.3 3.3189	0.85 0.033	RNA 2065	78.0 17500	184 41400	4900	3200	0.0887	0.433 0.955
	78.3 3.0827	100 3.9370	38 1.496	85.3 3.3583	0.85 0.033	RNA 3060	123.0 27700	290 65200	4900	3200	0.0966	0.810 1.786
83.1 3.2717	83.1 3.2717	100 3.9370	20 0.787	89.1 3.5079	0.85 0.033	RNA 1070	43.0 9670	103 23200	4500	2900	0.0784	0.322 0.710
	83.1 3.2717	100 3.9370	28 1.102	89.1 3.5079	0.85 0.033	RNA 2070	81.0 18200	195 43800	4500	2900	0.0926	0.470 1.036
	83.1 3.2717	105 4.1339	38 1.496	90.2 3.5496	0.85 0.033	RNA 3065	129 29000	308 69200	4500	2900	0.1012	0.865 1.907
88 3.4646	88 3.4646	110 4.3307	24 0.945	95.0 3.7402	0.85 0.033	RNA 1075	64.0 14400	155 34800	4300	2800	0.0864	0.577 1.272

Continued on next page.



NEEDLE ROLLER BEARINGS
FULL COMPLEMENT
WITHOUT INNER RINGS – continued

METRIC SERIES

- Check for availability.

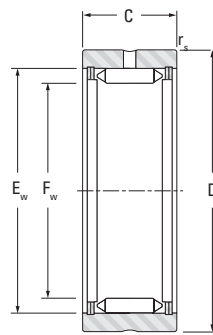

RNA

Shaft Dia.	F _w	D	C	E _w	r _{s min}	Bearing Designation	Load Ratings		Speed Rating		C ₀	Approx. Wt.
							Dynamic	Static	Oil	Grease		
							C	C ₀				
mm in	mm in	mm in	mm in	mm in	mm in		kN lbf		min ⁻¹		kg lbs	
88 3.4646	88 3.4646	110 4.3307	32 1.260	95.0 3.7402	0.85 0.033	RNA 2075	104 23400	253 56900	4300	2800	0.0983	0.767 1.691
	88 3.4646	110 4.3307	38 1.496	95.0 3.7402	0.85 0.033	RNA 3070	134 30100	325 73100	4300	2800	0.1050	0.906 1.997
96 3.7795	96 3.7795	115 4.5276	24 0.945	103.0 4.0551	0.85 0.033	RNA 1080	68.0 15300	170 38200	4000	2600	0.0918	0.510 1.124
	96 3.7795	115 4.5276	32 1.254	103.0 4.0551	0.85 0.033	RNA 2080	110 24700	275 61800	4000	2600	0.1045	0.694 1.530
	96 3.7795	120 4.7244	38 1.496	103.0 4.0551	0.85 0.033	RNA 3075	142 31900	355 79800	4000	2600	0.1117	1.098 2.421
99.5 3.9173	99.5 3.9173	120 4.7244	32 1.260	106.5 4.1929	1.35 0.053	RNA 2085	113 25400	285 64100	3800	2500	0.1072	0.787 1.735
	99.5 3.9173	125 4.9213	38 1.496	106.5 4.1929	0.85 0.033	RNA 3080	145 32600	365 82100	3800	2500	0.1145	1.220 2.690
104.7 4.1220	104.7 4.1220	125 4.9213	32 1.260	111.7 4.3976	1.35 0.053	RNA 2090	117 26300	300 67400	3600	2300	0.1113	0.837 1.845
	104.7 4.1220	130 5.1181	38 1.496	111.7 4.3976	1.35 0.053	RNA 3085	150 33700	390 87700	3600	2300	0.1189	1.252 2.760
109.1 4.2953	109.1 4.2953	130 5.1181	32 1.260	116.1 4.5709	1.35 0.053	RNA 2095	120 27000	315 70800	3500	2300	0.1225	0.882 1.944
	109.1 4.2953	135 5.3150	43 1.693	116.1 4.5709	1.35 0.053	RNA 3090	185 41600	480 108000	3500	2300	0.1280	1.522 3.355
114.7 4.5157	114.7 4.5157	135 5.3150	32 1.260	121.7 4.7913	1.35 0.053	RNA 2100	125 28100	330 74200	3300	2100	0.1188	0.677 1.493
	114.7 4.5157	140 5.5118	43 1.693	121.7 4.7913	1.35 0.053	RNA 3095	190 42700	505 114000	3300	2100	0.1327	1.551 3.419
119.2 4.6929	119.2 4.6929	140 5.5118	32 1.260	126.2 4.9685	1.35 0.053	RNA 2105	129 29000	340 76400	3200	2100	0.1221	0.941 2.075
	119.2 4.6929	145 5.7087	43 1.693	126.2 4.9685	1.35 0.053	RNA 3100	195 43800	520 117000	3200	2100	0.1364	1.645 3.627
124.5 4.9016	124.5 4.9016	145 5.7087	34 1.339	131.5 5.1772	1.35 0.053	RNA 2110	133 29900	360 80900	3000	2000	0.1260	1.015 2.238
	124.5 4.9016	150 5.9055	45 1.772	131.5 5.1772	1.35 0.053	RNA 3105	203 45600	550 124000	3000	2000	0.1408	1.762 3.885
132.5 5.2165	132.5 5.2165	155 6.1024	34 1.339	139.5 5.4921	1.35 0.053	RNA 2115	139 31200	380 85400	2900	1900	0.1318	1.205 2.657
	132.5 5.2165	160 6.2992	45 1.772	139.5 5.4921	1.35 0.053	RNA 3110	210 47200	580 130000	2900	1900	0.1471	2.037 4.49

Continued on next page.

Shaft Dia.	F _w	D	C	E _w	r _{s min}	Bearing Designation	Load Ratings		Speed Rating		C ₀	Approx. Wt.
							Dynamic	Static	Oil	Grease		
							C	C ₀				
mm in	mm in	mm in	mm in	mm in	mm in		kN lbf		min ⁻¹		kg lbs	
137 5.3937	137 5.3937	160 6.2992	34 1.339	144.0 5.6693	1.35 0.053	RNA 2120	142 31900	395 88800	2800	1800	0.1350	1.265 2.789
	137 5.3937	165 6.4961	45 1.772	144.0 5.6693	1.35 0.053	RNA 3115	215 48300	600 135000	2800	1800	0.1507	2.140 4.718
143.5 5.6496	143.5 5.6496	165 6.4961	34 1.339	150.5 5.9268	1.35 0.053	RNA 2125	145 32600	410 92200	2700	1800	0.1403	1.218 2.685
	143.5 5.6496	170 6.6929	45 1.772	150.5 5.9268	1.35 0.053	RNA 3120	224 50400	630 142000	2700	1800	0.1563	2.107 4.645
148 5.8268	148 5.8268	170 6.6929	34 1.339	155.0 6.1039	1.35 0.053	RNA 2130	150 33700	425 95500	2600	1700	0.1435	1.292 2.848
	158 6.2205	180 7.0866	36 1.417	165.0 6.4976	1.35 0.053	RNA 2140	157 35300	455 102000	2400	1600	0.1504	1.478 3.258
	158 6.2205	190 7.4803	52 2.047	166.0 6.5354	1.35 0.053	RNA 3130	275 61800	790 178000	2400	1600	0.1691	3.285 7.242
170.5 6.7126	170.5 6.7126	195 7.6772	36 1.417	177.5 6.9882	1.35 0.053	RNA 2150	165 37100	490 110000	2200	1400	0.1591	1.790 3.946
	170.5 6.7126	205 8.0709	52 2.047	178.5 7.0276	1.35 0.053	RNA 3140	290 65200	860 193000	2200	1400	0.1787	3.840 8.466
179.3 7.0591	179.3 7.0591	205 8.0709	36 1.417	186.3 7.3346	1.35 0.053	RNA 2160	170 38200	515 116000	2100	1400	0.1650	1.970 4.343
	179.3 7.0591	215 8.4646	52 2.047	187.3 7.3756	1.35 0.053	RNA 3150	300 67400	900 202000	2100	1400	0.1904	4.185 9.226
193.8 7.6299	193.8 7.6299	220 8.6614	42 1.654	200.8 7.9055	1.85 0.073	RNA 2170	233 52400	720 162000	2000	1300	0.1852	2.570 5.666
	193.8 7.6299	230 9.0551	57 2.244	201.9 7.9496	1.35 0.053	RNA 3160	360 80900	1110 250000	2000	1300	0.2071	4.955 10.924
202.6 7.9764	202.6 7.9764	230 9.0551	42 1.654	209.6 8.2520	1.85 0.073	RNA 2180	240 54000	750 169000	1900	1200	0.2145	2.835 6.250
	216 8.5039	245 9.6457	42 1.654	223.0 8.7795	1.85 0.073	RNA 2190	250 56200	800 180000	1800	1200	0.2004	3.210 7.077
	216 8.5039	255 10.0394	57 2.244	224.1 8.8236	1.85 0.073	RNA 3180	385 86600	1240 279000	1800	1200	0.2239	6.040 13.316
224.1 8.8228	224.1 8.8228	255 10.0394	42 1.654	231.1 9.0984	1.85 0.073	RNA 2200	257 57800	830 187000	1700	1100	0.2057	3.560 7.848
236 9.2913	236 9.2913	265 10.4331	42 1.654	243.1 9.5693	1.85 0.073	RNA 2210	279 62700	910 205000	1600	1000	0.2129	3.470 7.650
258.4 10.1732	258.4 10.1732	300 11.8110	64 2.520	268.4 10.5677	1.85 0.073	RNA 3220	490 110000	1650 371000	1500	980	0.2519	8.570 18.894
269.6 10.6142	269.6 10.6142	300 11.8110	49 1.929	276.6 10.8898	1.85 0.073	RNA 2240	345 77600	1190 268000	1400	910	0.2460	4.985 10.990
281.9 11.0984	281.9 11.0984	325 12.7953	64 2.520	291.9 11.4921	1.85 0.073	RNA 3240	520 117000	1800 405000	1300	850	0.2684	9.480 20.900
335 13.1890	335 13.1890	375 14.7638	54 2.126	343.0 13.5039	1.85 0.073	RNA 2300	460 103000	1690 380000	1100	720	0.2915	8.600 18.960



NEEDLE ROLLER BEARINGS
FULL COMPLEMENT
WITH INNER RINGS

METRIC SERIES

- Check for availability.

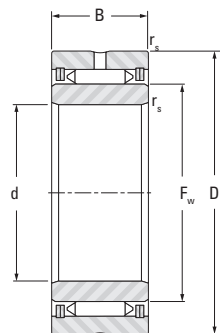

NA

Shaft Dia.	d	D	B	F _w	r _{s min}	Bearing Designation	Load Ratings		Speed Rating		C _g	Approx. Wt.
							Dynamic	Static	Oil	Grease		
							C	C ₀	min ⁻¹			
mm in	mm in	mm in	mm in	mm in	mm in		kN lbf		min ⁻¹			kg lbs
12 0.4724	12 0.4724	28 1.1024	15 0.591	17.6 0.6929	0.35 0.014	NA 1012 ⁽¹⁾	11.0 2470	16.5 3710	22000	14000	0.0261	0.050 0.110
15 0.5906	15 0.5906	32 1.2598	15 0.591	20.8 0.8189	0.65 0.026	NA 1015 ⁽¹⁾	12.4 2790	19.5 4380	18000	12000	0.0292	0.062 0.137
	15 0.5906	35 1.3780	22 0.866	22.1 0.8701	0.65 0.026	NA 2015	23.5 5280	37.5 8430	17000	11000	0.0345	0.117 0.258
17 0.6693	17 0.6693	35 1.3780	15 0.591	23.9 0.9409	0.65 0.026	NA 1017 ⁽¹⁾	13.7 3080	22.5 5060	16000	10000	0.0321	0.073 0.161
20 0.7874	20 0.7874	42 1.6535	18 0.709	28.7 1.1299	0.65 0.026	NA 1020	19.3 4340	33.5 7530	13000	8600	0.0374	0.130 0.287
	20 0.7874	42 1.6535	22 0.866	28.7 1.1299	0.65 0.026	NA 2020	28.5 6410	49.0 11000	13000	8600	0.0411	0.160 0.353
25 0.9843	25 0.9843	47 1.8504	18 0.709	33.5 1.3189	0.65 0.026	NA 1025	21.5 4830	39.0 8770	11000	7200	0.0415	0.151 0.333
	25 0.9843	47 1.8504	22 0.866	33.5 1.3189	0.65 0.026	NA 2025	33.0 7420	60.0 13500	11000	7200	0.0457	0.187 0.412
	25 0.9843	47 1.8504	30 1.181	33.5 1.3189	0.65 0.026	NA 22025	52.0 11700	94.0 21100	11000	7200	0.0537	0.259 0.571
30 1.1811	30 1.1811	52 2.0472	18 0.709	38.2 1.5039	0.65 0.026	NA 1030	23.5 5280	44.5 10000	10000	6500	0.0455	0.167 0.368
	30 1.1811	52 2.0472	22 0.866	38.2 1.5039	0.65 0.026	NA 2030	34.5 7760	66.0 14800	10000	6500	0.0501	0.213 0.470
	30 1.1811	52 2.0472	30 1.181	38.2 1.5039	0.65 0.026	NA 22030	57.0 12800	108 24300	10000	6500	0.0588	0.293 0.646
	30 1.1811	62 2.4409	30 1.181	44.0 1.7323	0.65 0.026	NA 3030	64.0 14400	125 28100	8600	5600	0.0607	0.497 1.10
35 1.3780	35 1.3780	58 2.2835	18 0.709	44.0 1.7323	0.65 0.026	NA 1035	26.0 5850	51.0 11500	8600	5600	0.0552	0.204 0.450
	35 1.3780	58 2.2835	22 0.866	44.0 1.7323	0.65 0.026	NA 2035	38.0 8540	75.0 16900	8600	5600	0.0552	0.253 0.558
	35 1.3780	58 2.2835	30 1.181	44.0 1.7323	0.65 0.026	NA 22035	63.0 14200	124 27900	8600	5600	0.0686	0.352 0.776
	35 1.3780	72 2.8346	36 1.417	49.7 1.9567	0.65 0.026	NA 3035	90.0 20200	183 41100	7600	4900	0.0706	0.815 1.80
40 1.5748	40 1.5748	65 2.5591	18 0.709	49.7 1.9567	0.85 0.033	NA 1040	28.5 6410	58.0 13000	7600	4900	0.0546	0.254 0.560
	40 1.5748	65 2.5591	22 0.866	49.7 1.9567	0.85 0.033	NA 2040	41.5 9330	85.0 19100	7600	4900	0.0601	0.315 0.694
	40 1.5748	65 2.5591	30 1.181	49.7 1.9567	0.85 0.033	NA 22040	68.0 15300	140 31500	7600	4900	0.0707	0.434 0.957
	40 1.5748	80 3.1496	36 1.417	55.4 2.1811	0.85 0.033	NA 3040	97.0 21800	204 45900	6900	4500	0.0759	0.993 2.19
45 1.7717	45 1.7717	72 2.8346	18 0.709	55.4 2.1811	0.85 0.033	NA 1045	30.5 6860	65.0 14600	6900	4500	0.0590	0.306 0.675

(1) No lubrication holes.

Continued on next page.

Shaft Dia.	d	D	B	F _w	r _{s min}	Bearing Designation	Load Ratings		Speed Rating		C _g	Approx. Wt.
							Dynamic	Static	Oil	Grease		
							C	C ₀	min ⁻¹			
mm in	mm in	mm in	mm in	mm in	mm in		kN lbf		min ⁻¹			kg lbs
45 1.7717	45 1.7717	72 2.8346	22 0.866	55.4 2.1811	0.85 0.033	NA 2045	45.0 10100	95.0 21400	6900	4500	0.0649	0.381 0.840
	45 1.7717	85 3.3465	38 1.496	62.1 2.4449	0.85 0.033	NA 3045	105.0 23600	230 51700	6100	4000	0.0823	1.13 2.50
50 1.9685	50 1.9685	80 3.1496	20 0.787	62.1 2.4449	0.85 0.033	NA 1050	33.0 7420	73.0 16400	6100	4000	0.0639	0.418 0.922
	50 1.9685	80 3.1496	28 1.102	62.1 2.4449	0.85 0.033	NA 2050	64.0 14400	142 31900	6100	4000	0.0754	0.603 1.33
	50 1.9685	90 3.5433	38 1.496	68.8 2.7087	0.85 0.033	NA 3050	113.0 25400	255 57300	5500	3600	0.0885	1.22 2.69
55 2.1654	55 2.1654	85 3.3465	20 0.787	68.8 2.7087	0.85 0.033	NA 1055	35.5 7980	80.0 18000	5500	3600	0.0687	0.453 0.999
	55 2.1654	85 3.3465	28 1.102	68.8 2.7087	0.85 0.033	NA 2055	69.0 15500	157 35300	5500	3600	0.0810	0.649 1.43
	55 2.1654	95 3.7402	38 1.496	72.6 2.8583	0.85 0.033	NA 3055	117.0 26300	268 60200	5200	3400	0.0811	1.31 2.88
60 2.3622	60 2.3622	90 3.5433	20 0.787	72.6 2.8583	0.85 0.033	NA 1060	37.0 8320	85.0 19100	5200	3400	0.0714	0.485 1.07
	60 2.3622	90 3.5433	28 1.102	72.6 2.8583	0.85 0.033	NA 2060	72.0 16200	165 37100	5200	3400	0.0842	0.695 1.53
	60 2.3622	100 3.9370	38 1.496	78.3 3.0827	0.85 0.033	NA 3060	123.0 27700	290 65200	4900	3200	0.0966	1.39 3.07
65 2.5591	65 2.5591	95 3.7402	28 1.102	78.3 3.0827	0.85 0.033	NA 2065	78.0 17500	184 41400	4900	3200	0.0887	0.757 1.67
	65 2.5591	105 4.1339	38 1.496	83.1 3.2717	0.85 0.033	NA 3065	129.0 29000	308 69200	4500	2900	0.1012	1.49 3.28
70 2.7559	70 2.7559	100 3.9370	20 0.787	83.1 3.2717	0.85 0.033	NA 1070	43.0 9670	103 23200	4500	2900	0.0784	0.567 1.25
	70 2.7559	100 3.9370	28 1.102	83.1 3.2717	0.85 0.033	NA 2070	81.0 18200	195 43800	4500	2900	0.0926	0.805 1.77
	70 2.7559	110 4.3307	38 1.496	88.0 3.4646	0.85 0.033	NA 3070	134.0 30100	325 73100	4300	2800	0.1050	1.57 3.46
75 2.9528	75 2.9528	110 4.3307	32 1.260	88.0 3.4646	0.85 0.033	NA 2075	104.0 23400	253 56900	4300	2800	0.0983	1.18 2.59
	75 2.9528	120 4.7244	38 1.496	96.0 3.7795	0.85 0.033	NA 3075	142.0 31900	355 79800	4000	2600	0.1117	1.92 4.24
80 3.1496	80 3.1496	115 4.5276	24 0.945	96.0 3.7795	0.85 0.033	NA 1080	68.0 15300	170 38200	4000	2600	0.0918	0.920 2.03
	80 3.1496	115 4.5276	32 1.254	96.0 3.7795	0.85 0.033	NA 2080	110.0 24700	275 61800	4000	2600	0.1045	1.24 2.73
	80 3.1496	125 4.9213	38 1.496	99.5 3.9173	0.85 0.033	NA 3080	145.0 32600	365 82100	3800	2500	0.1145	2.03 4.46
85 3.3465	85 3.3465	120 4.7244	32 1.260	99.5 3.9173	1.35 0.053	NA 2085	113.0 25400	285 64100	3800	2500	0.1072	1.30 2.87
	85 3.3465	130 5.1181	38 1.496	104.7 4.1220	1.35 0.053	NA 3085	150.0 33700	390 87700	3600	2300	0.1189	2.12 4.67
90 3.5433	90 3.5433	125 4.9213	32 1.260	104.7 4.1220	1.35 0.053	NA 2090	117.0 26300	300 67400	3600	2300	0.1113	1.37 3.02
	90 3.5433	135 5.3150	43 1.693	109.7 4.3189	1.35 0.053	NA 3090	185.0 41600	480 108000	3500	2300	0.1283	2.51 5.54
95 3.7402	95 3.7402	130 5.1181	32 1.260	109.1 4.2953	1.35 0.053	NA 2095	120.0 27000	315 70800	3500	2300	0.1225	1.43 3.15
	95 3.7402	140 5.5118	43 1.693	114.7 4.5157	1.35 0.053	NA 3095	190.0 42700	505 114000	3300	2100	0.1327	2.63 5.79
100 3.9370	100 3.9370	135 5.3150	32 1.260	114.7 4.5157	1.35 0.053	NA 2100	125.0 28100	330 74200	3300	2100	0.1188	1.50 3.30

Continued on next page.



NEEDLE ROLLER BEARINGS
FULL COMPLEMENT
WITH INNER RINGS – continued

METRIC SERIES

- Check for availability.

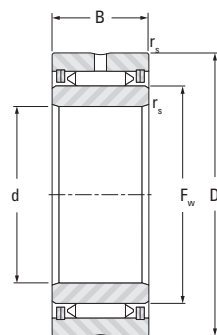

NA

Shaft Dia.	d	D	B	F _w	r _s min	Bearing Designation	Load Ratings		Speed Rating		C ₉	Approx. Wt.
							Dynamic	Static	Oil	Grease		
							C	C ₀	min ⁻¹			
mm in	mm in	mm in	mm in	mm in	mm in		kN lbf				kg lbs	
100 3.9370	100 3.9370	145 5.7087	43 1.693	119.2 4.6929	1.35 0.053	NA 3100	195.0 43800	520 117000	3200	2100	0.1364	2.74 6.03
105 4.1339	105 4.1339	140 5.5118	32 1.260	119.2 4.6929	1.35 0.053	NA 2105	129.0 29000	340 76400	3200	2100	0.1221	1.56 3.43
	105 4.1339	150 5.9055	45 1.772	124.7 4.9094	1.35 0.053	NA 3105	203.0 45600	550 124000	3000	2000	0.1409	2.99 6.59
110 4.3307	110 4.3307	145 5.7087	34 1.339	124.7 4.9094	1.35 0.053	NA 2110	133.0 29900	360 80900	3000	2000	0.1261	1.72 3.79
	110 4.3307	160 6.2992	45 1.772	132.5 5.2165	1.35 0.053	NA 3110	210.0 47200	580 130000	2900	1900	0.1471	3.53 7.79
115 4.5276	115 4.5276	155 6.1024	34 1.339	132.5 5.2165	1.35 0.053	NA 2115	139.0 31200	380 85400	2900	1900	0.1318	2.10 4.63
	115 4.5276	165 6.4961	45 1.772	137.0 5.3937	1.35 0.053	NA 3115	215.0 48300	600 135000	2800	1800	0.1507	3.66 8.07
120 4.7244	120 4.7244	160 6.2992	34 1.339	137.0 5.3937	1.35 0.053	NA 2120	142.0 31900	395 88800	2800	1800	0.1350	2.17 4.78
	120 4.7244	170 6.6929	45 1.772	143.5 5.6496	1.35 0.053	NA 3120	224.0 50400	630 142000	2700	1800	0.1563	3.79 8.36
125 4.9213	125 4.9213	165 6.4961	34 1.339	143.5 5.6496	1.35 0.053	NA 2125	145.0 32600	410 92200	2700	1800	0.1403	2.24 4.94
	130 5.1181	170 6.6929	34 1.339	148.0 5.8268	1.35 0.053	NA 2130	150.0 33700	425 95500	2600	1700	0.1435	2.33 5.13
140 5.5118	140 5.5118	180 7.0866	36 1.417	158.0 6.2205	1.35 0.053	NA 2140	157.0 35300	455 102000	2400	1600	0.1504	2.64 5.83
	140 5.5118	205 8.0709	52 2.047	170.5 6.7126	1.35 0.053	NA 3140	290.0 65200	860 193000	2200	1400	0.1787	6.84 15.1
150 5.9055	150 5.9055	195 7.6772	36 1.417	170.5 6.7126	1.35 0.053	NA 2150	165.0 37100	490 110000	2200	1400	0.1591	3.23 7.12
160 6.2992	160 6.2992	205 8.0709	36 1.417	179.3 7.0591	1.35 0.053	NA 2160	170.0 38200	515 116000	2100	1400	0.1650	3.40 7.50
170 6.6929	170 6.6929	220 8.6614	42 1.654	193.8 7.6299	1.35 0.053	NA 2170	233.0 52400	720 162000	2000	1300	0.1852	4.77 10.5
180 7.0866	180 7.0866	230 9.0551	42 1.654	202.6 7.9764	1.35 0.053	NA 2180	240.0 54000	750 169000	1900	1200	0.2145	5.01 11.0
190 7.4803	190 7.4803	245 9.6457	42 1.654	216.0 8.5039	1.35 0.053	NA 2190	250.0 56200	800 180000	1800	1200	0.2004	5.89 13.0
200 7.8740	200 7.8740	255 10.0394	42 1.654	224.1 8.8228	1.35 0.053	NA 2200	257.0 57800	830 187000	1700	1100	0.2057	6.15 13.6

SINGLE-ROW RADIAL BEARINGS – METRIC SERIES

The radial cylindrical roller bearing has integral end ribs on the outer ring for end guiding the cylindrical rollers. The inner ring is separable for simplified mounting and removal.

All NU design bearings are available on request without inner rings. For this requirement add letter R in the prefix.

The modified line contact between the cylindrical rollers and raceways reduces edge stressing.

REFERENCE STANDARDS ARE:

- DIN 5412 single-row cylindrical roller bearings.
- ISO 246 & DIN 5412 angle rings (thrust collar).

TYPES OF METRIC SERIES CYLINDRICAL ROLLER RADIAL BEARINGS

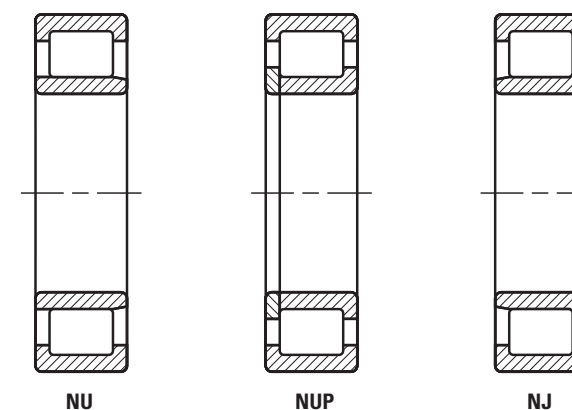

SUFFIXES

E.TVP E-design bearing, molded window type cage of engineered polymer.

M Machined brass cages.

CONSTRUCTION

Cylindrical roller radial bearings can be recognized by the arrangement of their end ribs. Bearings of NU design have two ribs on the outer ring, the inner ring being cylindrical, making them well-suited for use as floating bearings. They are separable, which simplifies mounting and removal. Radial cylindrical roller bearings of NJ design have two ribs on the outer ring and one rib on the inner ring. They can accept axial loading in one direction.

Bearings of NUP design have two ribs on the outer ring, and one fixed and one loose rib (a flat washer) on the inner ring. These radial cylindrical roller bearings are used for locating purposes and can accept reversing axial loading. A radial cylindrical roller bearing of NJ design with an HJ Type thrust collar forms a locating bearing similar to the NUP design.

Cylindrical roller bearings of RNU Type, available on request, are supplied without an inner ring so that the cylindrical rollers run directly on a hardened and ground shaft. For most general applications, the shaft may be machined to g6 and the housing bore to K6 tolerances.

CAGE DESIGNS

The majority of cylindrical roller bearings of series 2..E, 22..E, 3..E and 23..E use cages of glass-fiber reinforced nylon. This cage construction allows bearings to be designed with maximum load carrying capability. These cages can also be used at operating temperatures of up to 120° C over extended periods. When bearings are lubricated with an oil, presence of additives may reduce operating life if the temperature exceeds 100° C over extended periods. Furthermore, stagnant oil may affect the performance of the cage at these temperatures, requiring oil change intervals to be strictly observed.

Suffix M indicates that the bearings use machined brass cages.



DIMENSIONAL ACCURACY

TOLERANCES AND BEARING CLEARANCE

Metric series radial cylindrical roller bearings are available in various tolerance classes and clearance groups. Single-row cylindrical roller bearings are made to normal clearance group C0, although bearings with radial clearance groups C2, C3 and C4 may be obtained on request.

For tolerances of radial cylindrical roller bearings see the engineering section. For radial internal clearances of radial cylindrical roller bearings see the engineering section.

ALIGNMENT

The modified line contact between the cylindrical rollers and raceways of cylindrical roller bearings reduces stress concentration at ends of the rollers and provides some aligning capability. The angular alignment of single-row cylindrical roller bearings must not exceed a maximum of four angular minutes at a load of $P/C \leq 0.2$ (P = equivalent dynamic load, kN). At higher applied loads, or with presence of greater misalignment, consultation with engineering is strongly encouraged.

MOUNTING DIMENSIONS

The bearing inner and outer rings should be mounted against the stepped portion on the shaft and the shoulder of the housing. Under no circumstances should they interfere with the shaft or housing fillets. For this reason, the maximum fillet radius $r_{as \max}$ of the mating component must be no greater than the minimum chamfer dimension of the corresponding cylindrical roller bearing ring corner $r_{s \min}$.

The shoulder of the mating components must be such that, even with the maximum permissible single chamfer dimension of the corresponding bearing ring, there is an adequate contact surface area. Table B-23 lists the maximum fillet radius $r_{as \max}$ and the minimum shoulder height. At high axial loads the ribs must be supported over half their height.

$$\left(\frac{H+E}{2} \text{ and } \frac{F+J}{2} \right)$$

where from bearing tables:

- F** raceway diameter of the inner ring
- E** raceway diameter of the outer ring
- J** rib diameter of the inner ring
- H** rib diameter of the outer ring

The shaft can be mounted and removed if the mounting dimensions shown in Table B-24 on page B-185 are observed.

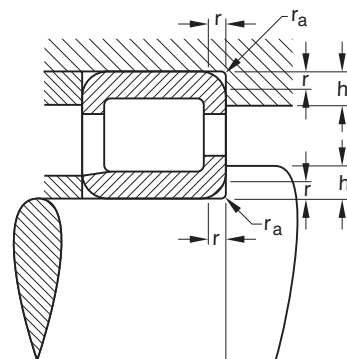

Table B-23. Abutment dimensions as specified in DIN 5418 for metric series bearings

$r_{s \min}$	$r_{as \max}$	h_{\min} Bearing series	
		10	2..E 3..E 22..E 23..E
mm in	mm in	mm in	mm in
0.3 0.0118	0.3 0.0118	1 0.0394	1.2 0.0472
0.6 0.0236	0.6 0.0236	1.6 0.630	2.1 0.0827
1 0.0394	1 0.0394	2.3 0.0905	2.8 0.1102
1.1 0.0433	1 0.0394	3 0.1181	3.5 0.1378
1.5 0.0591	1.5 0.0591	3.5 0.1378	4.5 0.1772
2 0.0787	2 0.0787	4.4 0.1732	5.5 0.2165
2.1 0.0827	2.1 0.0827	5.1 0.2008	6 0.2362
3 0.1181	2.5 0.0984	6.2 0.2441	7 0.2756
4 0.1575	3 0.1181	7.3 0.2874	8.5 0.3346
5 0.1969	4 0.1575	9 0.3543	10 0.3937
6 0.2362	5 0.1969	11.5 0.4528	13 0.5118

Shaft tolerances for cylindrical roller bearings with inner rings are given in Table B-19 on page B-151.

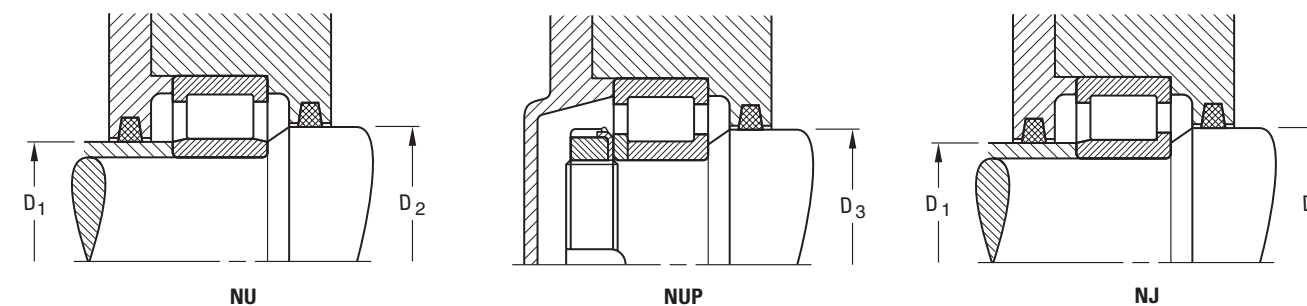

Table B-24. Mounting dimensions for metric series single-row cylindrical roller bearings

Bearing Reference Number	Shaft Dia.	Bearing Series								
		10			2..E		23..E		3..E	
		D1 max.	D2 min.	D3 min.	D1 max.	D2 min.	D3 min.	D1 max.	D2 min.	D3 min.
mm in	mm in	mm in	mm in	mm in	mm in	mm in	mm in	mm in	mm in	
02	15 0.5905				20 0.7874	23 0.9055	26 1.0236			
03	17 0.6693				21 0.8268	25 0.9843	27 1.0630	24 0.9449	27 1.0630	30 1.1811
04	20 0.7874	25 0.9843	27 1.0630		26 1.0236	29 1.1417	32 1.2598	27 1.0630	30 1.1811	33 1.2992
05	25 0.9843	30 1.1811	32 1.2598		31 1.2205	34 1.3386	37 1.4567	33 1.2992	37 1.4567	40 1.5748
06	30 1.1811	35 1.3779	38 1.4961		37 1.4567	40 1.5748	44 1.7323	40 1.5748	44 1.7323	48 1.8898
07	35 1.3779	41 1.6142	44 1.7323		43 1.6929	46 1.8110	50 1.9685	45 1.7716	48 1.8898	53 2.0866
08	40 1.5748	46 1.8110	49 1.9291		49 1.9291	52 2.0472	56 2.2047	51 2.0079	55 2.1653	60 2.3622
09	45 1.7716	52 2.0472	54 2.1260		54 2.1260	57 2.2441	61 2.4016	57 2.2441	60 2.3622	66 2.5984
10	50 1.9685	57 2.2441	59 2.3228		58 2.2835	62 2.4409	67 2.6378	63 2.4803	67 2.6378	73 2.8740
11	55 2.1653	63 2.4803	66 2.5984		65 2.5591	68 2.6772	73 2.8740	69 2.7165	72 2.8346	80 3.1496
12	60 2.3622	68 2.6772	71 2.7953		71 2.7953	75 2.9528	80 3.1496	75 2.9528	79 3.1102	86 3.3858
13	65 2.5591	73 2.8740	76 2.9921		77 3.0315	81 3.1890	87 3.4252	81 3.1890	85 3.3464	93 3.6614
14	70 2.7559	78 3.0709	82 3.2283		82 3.2284	86 3.3858	92 3.6220	87 3.4252	92 3.6220	100 3.9370
15	75 2.9528	83 3.2677	87 3.4252		87 3.4252	90 3.5433	96 3.7795	93 3.6614	97 3.8189	106 4.1732
16	80 3.1496	90 3.5433	94 3.7008		94 3.7008	97 3.8189	104 4.0945	99 3.8976	105 4.1339	114 4.4882



LOAD RATINGS

CYLINDRICAL ROLLER BEARING
MAXIMUM ALLOWABLE AXIAL LOAD

Metric series cylindrical roller bearings of NUP, NJ, as well as NU or NJ designs with a thrust collar can transmit axial loads if they are radially loaded at the same time. The allowable axial load ratio F_a/C of 0.1 maximum depends to a great extent on the magnitude of radial load, the operating speed, type of lubricant used, the operating temperature, and heat transfer conditions at the bearing location. The heat balance achieved at the bearing location is used as a basis for determination of the allowable axial load.

The nomogram on page B-187 should be used to determine the allowable axial load F_{az} based on the following operating conditions:

- The axial load is of constant direction and magnitude.
- Radial load ratio $F_r/C < 0.2$.
- Ratio of axial load to radial load $F_a/F_r < 0.4$.
- The temperature of the bearing is 80° C at an ambient temperature of 20° C.
- Lubricating oil is ISO VG 100 using oil bath lubrication or circulating oil.
- As an alternative, the bearing may be lubricated with a grease using the above specified base oil and viscosity. Use of EP additives will be necessary, although considerably shorter relubrication intervals may be expected than with purely radially loaded radial cylindrical roller bearings.

EXAMPLE OF USING THE NOMOGRAM

From the lower part of the nomogram, determine the intersection point of the inner ring bore diameter and the dimension series of the bearing. From the upper part, the allowable axial load ratio F_{az}/C can be found as a function of the operating speed, n .

For a cylindrical roller radial bearing **NU2207E.TVP**

$C = 63 \text{ kN}; d = 35 \text{ mm}$

$n = 2000 \text{ min}^{-1}$

$F_r = 10 \text{ kN}$

From the nomogram:

$F_{az}/C = 0.06$

Then $F_{az} = 0.06 \cdot 63$

The calculated allowable axial load F_{az} is 3.78 kN

It should be noted that an axial load as high as that determined by means of the nomogram should not be applied if an oil of rated kinematic viscosity lower than ISO VG 100 is used. Suitable EP additives, which are known for fatigue life improving qualities, may allow for an increase in applied axial load subject to thorough testing.

HIGHER APPLIED AXIAL LOADS

Axial loads greater than those determined by means of the nomogram may be considered, providing they are to be applied intermittently. Also, the bearing should be cooled using circulating oil lubrication. If the operating temperature, due to the internal friction and the higher axial load, exceeds 80° C, a more viscous oil must be used.

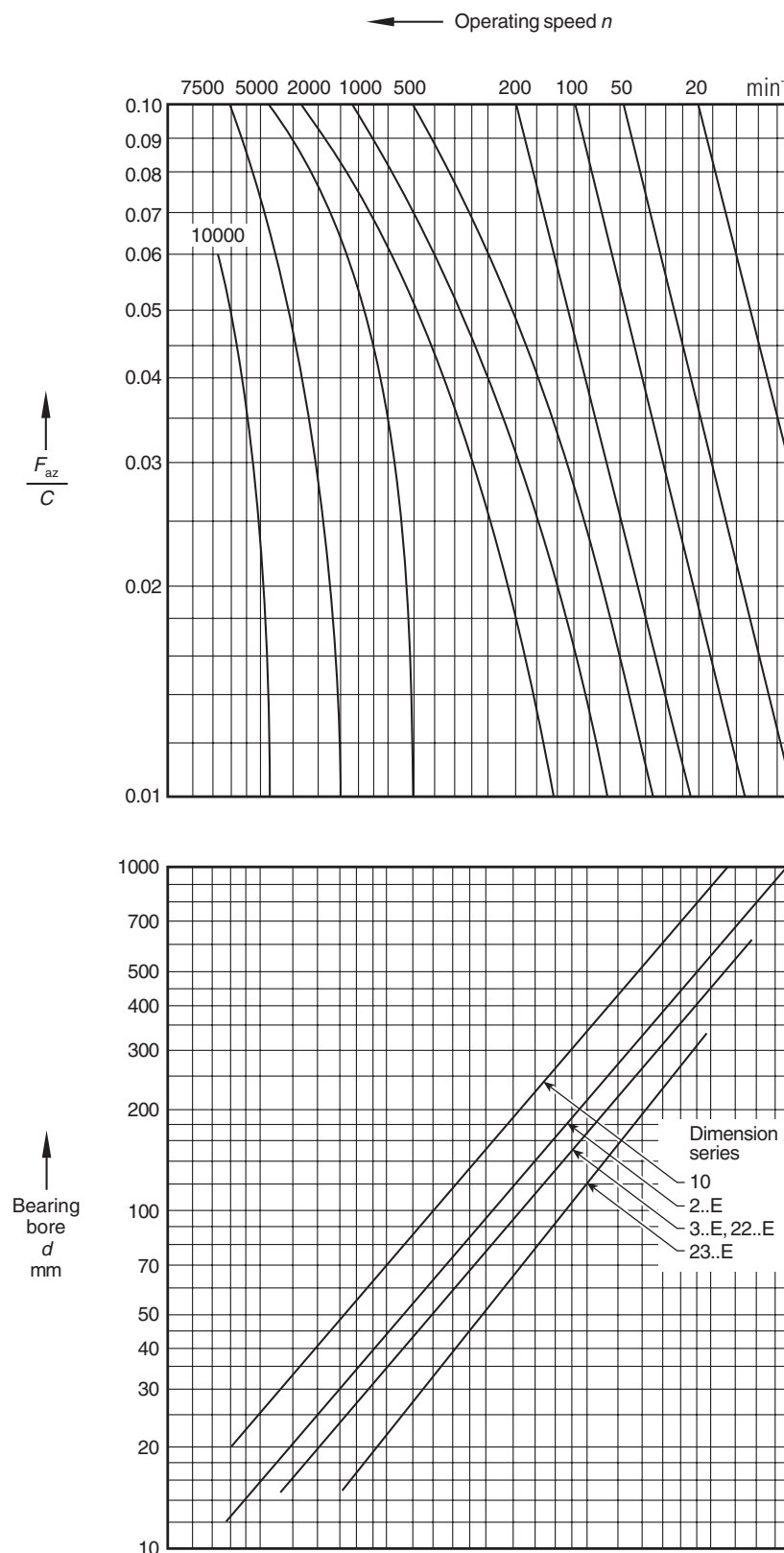
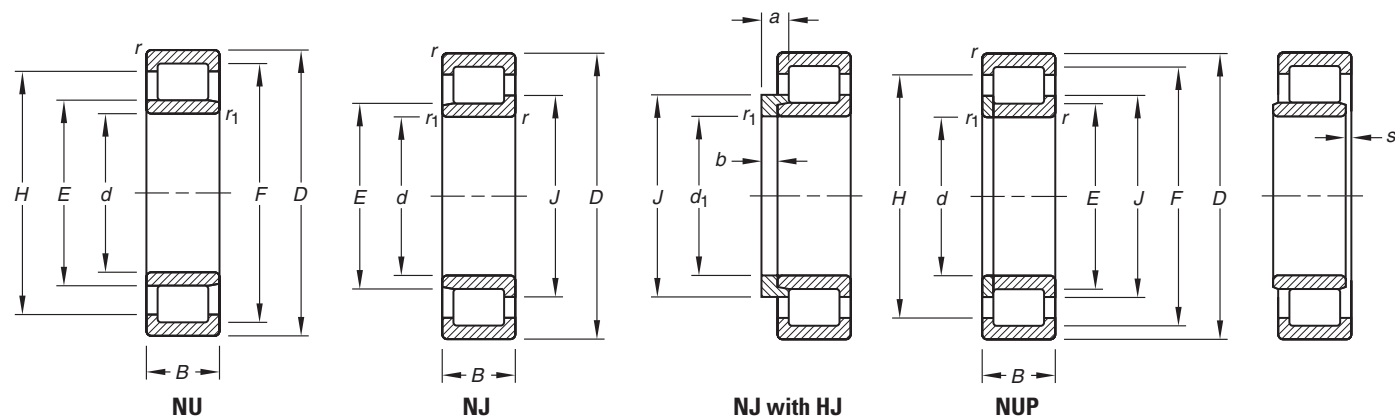

Fig. B-44. Nomogram for determining the allowable axial load F_{az}



CYLINDRICAL ROLLER RADIAL BEARINGS SINGLE-ROW

METRIC SERIES



Bearing Number	Bore d or d ₁	O.D. D	Width B	chamfer		Backing Dia.		Rib Dia.		a	b	s ⁽¹⁾	Load Ratings		Geometry Factor C _G	Reference Speed Grease Oil	Thermal Ratings	Wt.	
				min. r ₁	min. r	Shaft E	Housing F	Inner J	Outer H				Dynamic C	Static C ₀				Brg.	Thrust Collar
				mm in	mm in	mm in	mm in	mm in	mm in				mm in	mm in				mm in	mm in
NJ202E.TVP	15 0.5906	35 1.3780	11 0.4331	0.3 0.01	0.6 0.02	19.3 0.76	30.3 1.19	21.8 0.86	27.8 1.09	5.0 0.20	2.5 0.10		11.6 2610	13.9 3120	0.0327	14000	17000	0.047 0.104	0.015 0.007
NU202E.TVP	15 0.5906	35 1.3780	11 0.4331	0.3 0.01	0.6 0.02	19.3 0.76	30.3 1.19		27.8 1.09			1.0 0.04	11.6 2610	13.9 3120	0.0327	14000	17000	0.047 0.104	
NJ203E.TVP	17 0.6693	40 1.5748	12 0.4724	0.3 0.01	0.6 0.02	22.1 0.87	35.1 1.38	24.7 0.97	32.0 1.26	5.5 0.22	3.0 0.12		16.0 3600	18.9 4250	0.0366	12000	15000	0.068 0.150	0.020 0.009
NU203E.TVP	17 0.6693	40 1.5748	12 0.4724	0.3 0.01	0.6 0.02	22.1 0.87	35.1 1.38		32.0 1.26			1.2 0.05	16.0 3600	18.9 4250	0.0366	12000	15000	0.068 0.150	
NUP203E.TVP	17 0.6693	40 1.5748	12 0.4724	0.3 0.01	0.6 0.02	22.1 0.87	35.1 1.38	24.7 0.97	32.0 1.26				16.0 3600	18.9 4250	0.0366	12000	15000	0.068 0.150	
NJ2203E.TVP	17 0.6693	40 1.5748	16 0.6299	0.3 0.01	0.6 0.02	22.1 0.87	35.1 1.38	24.7 0.97	32.0 1.26	6.0 0.24	3.0 0.12		23.3 5240	25.3 5690	0.0402	11000	13000	0.091 0.201	0.022 0.010
NU2203E.TVP	17 0.6693	40 1.5748	16 0.6299	0.3 0.01	0.6 0.02	22.1 0.87	35.1 1.38		32.0 1.26			1.0 0.04	23.3 5240	25.3 5690	0.0402	11000	13000	0.091 0.201	
NUP2203E.TVP	17 0.6693	40 1.5748	16 0.6299	0.3 0.01	0.6 0.02	22.1 0.87	35.1 1.38	24.7 0.97	32.0 1.26				23.3 5240	25.3 5690	0.0402	11000	13000	0.091 0.201	
NJ303E.TVP	17 0.6693	47 1.8504	14 0.5512	0.6 0.02	1.1 0.04	24.2 0.95	40.2 1.58	27.6 1.09	36.8 1.45	6.5 0.26	4.0 0.16		22.8 5130	26.7 6000	0.0392	11000	13000	0.121 0.267	0.012 0.026
NU303E.TVP	17 0.6693	47 1.8504	14 0.5512	0.6 0.02	1.1 0.04	24.2 0.95	40.2 1.58		36.8 1.45			1.2 0.05	22.8 5130	26.7 6000	0.0392	11000	13000	0.121 0.267	
NJ204E.TVP	20 0.7874	47 1.8504	14 0.5512	0.6 0.02	1.0 0.04	26.5 1.04	41.5 1.63	29.9 1.18	38.4 1.51	5.5 0.22	3.0 0.12		26.5 5960	29.0 6520	0.0436	11000	13000	0.133 0.293	0.024 0.011
NU204E.TVP	20 0.7874	47 1.8504	14 0.5512	0.6 0.02	1.0 0.04	26.5 1.04	41.5 1.63		38.4 1.51			1.0 0.04	26.5 5960	29.0 6520	0.0436	11000	13000	0.133 0.293	
NUP204E.TVP	20 0.7874	47 1.8504	14 0.5512	0.6 0.02	1.0 0.04	26.5 1.04	41.5 1.63	29.9 1.18	38.4 1.51				26.5 5960	29.0 6520	0.0433	11000	13000	0.133 0.293	
NJ2204E.TVP	20 0.7874	47 1.8504	18 0.7087	0.6 0.02	1.0 0.04	26.5 1.04	41.5 1.63	29.9 1.18	38.4 1.51	6.5 0.26	3.0 0.12		32.7 7350	34.1 7670	0.0459	9400	11000	0.142 0.313	0.012 0.026
NU2204E.TVP	20 0.7874	47 1.8504	18 0.7087	0.6 0.02	1.0 0.04	26.5 1.04	41.5 1.63		38.4 1.51			1.8 0.07	32.7 7350	34.1 7670	0.0459	9400	11000	0.142 0.313	
NUP2204E.TVP	20 0.7874	47 1.8504	18 0.7087	0.6 0.02	1.0 0.04	26.5 1.04	41.5 1.63	29.9 1.18	38.4 1.51				32.7 7350	34.1 7670	0.0459	9400	11000	0.142 0.313	
NJ304E.TVP	20 0.7874	52 2.0472	15 0.5906	0.6 0.02	1.1 0.04	27.5 1.08	45.5 1.79	31.4 1.24	41.8 1.65	6.5 0.26	4.0 0.16		28.0 6290	32.6 7330	0.0435	10000	12000	0.152 0.335	0.017 0.037
NU304E.TVP	20 0.7874	52 2.0472	15 0.5906	0.6 0.02	1.1 0.04	27.5 1.08	45.5 1.79		41.8 1.65			1.1 0.04	28.0 6290	32.6 7330	0.0435	10000	12000	0.152 0.335	

⁽¹⁾ Max. axial displacement

Continued on next page.

Bearing Number	Bore d or d ₁	O.D. D	Width B	chamfer		Backing Dia.		Rib Dia.		a	b	s ⁽¹⁾	Load Ratings		Geometry Factor C _G	Reference Speed Grease Oil	Thermal Ratings	Wt.	
				min. r ₁	min. r	Shaft E	Housing F	Inner J	Outer H				Dynamic C	Static C ₀				Brg.	Thrust Collar
				mm in	mm in	mm in	mm in	mm in	mm in				mm in	mm in				mm in	mm in
NUP304E.TVP	20 0.7874	52 2.0472	15 0.5906	0.6 0.02	1.1 0.04	27.5 1.08	45.5 1.79	31.4 1.24	41.8 1.65				28.0 6290	32.6 7330	0.0435	10000	12000	0.152 0.335	
NJ2304E.TVP	20 0.7874	52 2.0472	21 0.8268	0.6 0.02	1.1 0.04	27.5 1.08	45.5 1.79	31.4 1.24	41.8 1.65	7.5 0.30	4.0 0.16		40.0 8990	42.9 9640	0.0475	8200	9800	0.207 0.456	0.020 0.044
NJ205E.TVP	25 0.9843	52 2.0472	15 0.5906	0.6 0.02	1.0 0.04	31.5 1.24	46.5 1.83	34.9 1.37	43.3 1.70	6.0 0.24	3.0 0.12		29.8 6700	31.0 6970	0.0489	9600	12000	0.140 0.309	0.031 0.014
NU205E.TVP	25 0.9843	52 2.0472	15 0.5906	0.6 0.02	1.0 0.04	31.5 1.24	46.5 1.83		43.3 1.70			1.3 0.05	29.8 6700	31.0 6970	0.0489	9600	12000	0.140 0.309	
NUP205E.TVP	25 0.9843	52 2.0472	15 0.5906	0.6 0.02	1.0 0.04	31.5 1.24	46.5 1.83	34.9 1.37	43.3 1.70				29.8 6700	31.0 6970	0.0486	9600	12000	0.140 0.309	
NJ2205E.TVP	25 0.9843	52 2.0472	18 0.7087	0.6 0.02	1.0 0.04	31.5 1.24	46.5 1.83	34.9 1.37	43.3 1.70	6.5 0.26	3.0 0.12		36.7 8250	36.5 8210	0.0515	8100	9700	0.160 0.353	0.014 0.031
NU2205E.TVP	25 0.9843	52 2.0472	18 0.7087	0.6 0.02	1.0 0.04	31.5 1.24	46.5 1.83		43.3 1.70			1.7 0.07	36.7 8250	36.5 8210	0.0515	8100	9700	0.160 0.353	
NUP2205E.TVP	25 0.9843	52 2.0472	18 0.7087	0.6 0.02	1.0 0.04	31.5 1.24	46.5 1.83	34.9 1.37	43.3 1.70				36.7 8250	36.5 8210	0.0515	8100	9700	0.160 0.353	
NJ305E.TVP	25 0.9843	62 2.4409	17 0.6693	1.1 0.04	1.1 0.04	34.0 1.34	54.0 2.13	38.3 1.51	50.1 1.97	7.0 0.28	4.0 0.16		38.9 8750	42.8 9620	0.0508	8500	10000	0.243 0.536	0.025 0.055
NU305E.TVP	25 0.9843	62 2.4409	17 0.6693	1.1 0.04	1.1 0.04	34.0 1.34	54.0 2.13		50.1 1.97			1.5 0.06	38.9 8750	42.8 9620	0.0508	8500	10000	0.243 0.536	
NUP305E.TVP	25 0.9843	62 2.4409	17 0.6693	1.1 0.04	1.1 0.04	34.0 1.34	54.0 2.13	38.3 1.51	50.1 1.97				38.9 8750	42.8 9620	0.0508	8500	10000	0.243 0.536	
NJ2305E.TVP	25 0.9843	62 2.4409	24 0.9449	1.1 0.04	1.1 0.04	34.0 1.34	54.0 2.13	38.3 1.51	50.1 1.97	8.0 0.31	4.0 0.16		57.6 12900	58.1 13100	0.0561	6900	8300	0.348 0.767	0.026 0.057
NU2305E.TVP	25 0.9843	62 2.4409	24 0.9449	1.1 0.04	1.1 0.04	34.0 1.34	54.0 2.13		50.1 1.97			1.9 0.07	57.6 12900	58.1 13100	0.0561	6900	8300	0.348 0.767	
NJ206E.TVP	30 1.1811	62 2.4409	16 0.6299	0.6 0.02	1.0 0.04	37.5 1.48	55.5 2.19	41.4 1.63	52.0 2.05	7.0 0.28	4.0 0.16		39.0 8770	40.4 9080	0.0552	8000	9700	0.206 0.454	0.055 0.025
NU206E.TVP	30 1.1811	62 2.4409	16 0.6299	0.6 0.02	1.0 0.04	37.5 1.48	55.5 2.19		52.0 2.05			1.4 0.06	39.0 8770	40.4 9080	0.0280	8000	9700	0.206 0.454	
NUP206E.TVP	30 1.1811	62 2.4409	16 0.6299	0.6 0.02	1.0 0.04	37.5 1.48	55.5 2.19	41.4 1.63	52.0 2.05				39.0 8770	40.4 9080	0.0552	8000	9700	0.206 0.454	
NJ2206E.TVP	30 1.1811	62 2.4409	20 0.7874	0.6 0.02	1.0 0.04	37.5 1.48	55.5 2.19	41.4 1.63	52.0 2.05	7.5 0.30	4.0 0.16		51.5 11600	50.1 11300	0.0591	6800	8100	0.255 0.562	0.025 0.055
NU2206E.TVP	30 1.1811	62 2.4409	20 0.7874	0.6 0.02	1.0 0.04	37.5 1.48	55.5 2.19		52.0 2.05			1.6 0.06	51.5 11600	50.1 11300	0.0591	6800	8100	0.255 0.562	
NUP2206E.TVP	30 1.1811	62 2.4409	20 0.7874	0.6 0.02	1.0 0.04	37.5 1.48	55.5 2.19	41.4 1.63	52.0 2.05				51.5 11600	50.1 11300	0.0591	6800	8100	0.255 0.562	
NJ306E.TVP	30 1.1811	72 2.8346	19 0.7480	1.1 0.04	1.1 0.04	40.5 1.59	62.5 2.46	45.1 1.78	58.3 2.30	8.5 0.33	5.0 0.20		52.1 11700	54.6 12300	0.0581	7400	8800	0.370 0.816	0.042 0.093
NU306E.TVP	30 1.1811	72 2.8346	19 0.7480	1.1 0.04	1.1 0.04	40.5 1.59	62.5 2.46		58.3 2.30			1.9 0.07	52.1 11700	54.6 12300	0.0581	7400	8800	0.370 0.816	
NUP306E.TVP	30 1.1811	72 2.8346	19 0.7480	1.1 0.04	1.1 0.04	40.5 1.59	62.5 2.46	45.1 1.78	58.3 2.30				52.1 11700	54.6 12300	0.0581	7400	8800	0.370 0.816	
NJ2306E.TVP	30 1.1811	72 2.8346	27 1.0630	1.1 0.04	1.1 0.04	40.5 1.59	62.5 2.46	45.1 1.78	58.3 2.30	9.5 0.37	5.0 0.20		79.5 17900	75.9 17100	0.0645	6000	7200	0.530 1.169	0.095 0.043
NUP2306E.TVP	30 1.1811	72 2.8346	27 1.0630	1.1 0.04	1.1 0.04	40.5 1.59	62.5 2.46	45.1 1.78	58.3 2.30				79.5 17900	75.9 17100	0.0642	6000	7200	0.530 1.169	
NJ207E.TVP	35 1.3780	72 2.8346	17 0.6693	0.6 0.02	1.1 0.04	44.0 1.73	64.0 2.52	48.0 1.89	60.1 2.37	7.0 0.28	4.0 0.16		52.2 11700	51.8 116					



CYLINDRICAL ROLLER RADIAL BEARINGS SINGLE-ROW - continued

METRIC SERIES

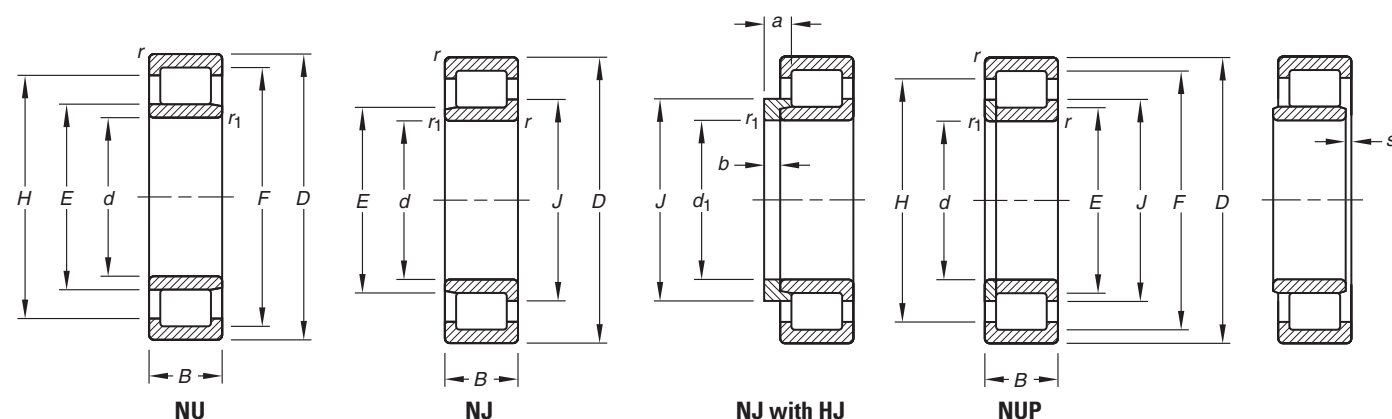

Bearing Number	Bore d or d ₁	O.D. D	Width B	chamfer		Backing Dia.		Rib Dia.		a	b	s ⁽¹⁾	Load Ratings		Geometry Factor C _g	Refer-ence Speed Grease	Thermal Ratings		Wt.	
				min. r ₁	min. r	Shaft E	Housing F	Inner J	Outer H				Dynamic C	Static C ₀			min ⁻¹	Oil	Brg.	Thrust Collar
				mm in	mm in	mm in	mm in	mm in	mm in				mm in	mm in			mm in	mm in	mm in	mm in
NUP307E.TVP	35 1.3780	80 3.1496	21 0.8268	1.1 0.04	1.5 0.06	46.2 1.82	70.2 2.76	51.2 2.02	65.7 2.59				66.4 14900	67.3 15100	0.0653	6700	7900	0.485 1.069		
NU2307E.TVP	35 1.3780	80 3.1496	31 1.2205	1.1 0.04	1.5 0.06	46.2 1.82	70.2 2.76		65.7 2.59			3.0 0.12	102.0 22900	93.7 21100	0.0724	5600	6600	0.720 1.588		
NUP208E.TVP	40 1.5748	80 3.1496	18 0.7087	1.1 0.04	1.1 0.04	49.5 1.95	71.5 2.81	54.1 2.13	67.3 2.65				57.7 13000	57.3 12900	0.0668	6200	7500	0.380 0.838		
NU2208E.TVP	40 1.5748	80 3.1496	23 0.9055	1.1 0.04	1.1 0.04	49.5 1.95	71.5 2.81		67.3 2.65			2.3 0.09	79.8 17900	73.8 16600	0.0724	5300	6300	0.490 1.080		
NUP308E.TVP	40 1.5748	90 3.5433	23 0.9055	1.5 0.06	1.5 0.06	52.0 2.05	80.0 3.15	57.7 2.27	74.9 2.95				82.7 18600	84.0 18900	0.0714	6000	7100	0.660 1.455		
NJ2308E.TVP	40 1.5748	90 3.5433	33 1.2992	1.5 0.06	1.5 0.06	52.0 2.05	80.0 3.15	57.7 2.27	74.9 2.95	12.5 0.49	7.0 0.28		123.0 27700	115.0 25900	0.0788	5000	5900	0.950 2.095	0.091 0.201	
NU2209E.TVP	45 1.7717	85 3.3465	23 0.9055	1.1 0.04	1.1 0.04	54.5 2.15	76.5 3.01		72.4 2.85			2.3 0.09	87.0 19600	77.7 17500	0.0775	4800	5700	0.530 1.169		
NUP2209E.TVP	45 1.7717	85 3.3465	23 0.9055	1.1 0.04	1.1 0.04	54.5 2.15	76.5 3.01	59.1 2.33	72.4 2.85				87.0 19600	77.7 17500	0.0775	4800	5700	0.530 1.169		
NJ309E.TVP	45 1.7717	100 3.9370	25 0.9843	1.5 0.06	1.5 0.06	58.5 2.30	88.5 3.48	64.6 2.54	83.1 3.27	11.5 0.45	7.0 0.28		104.0 23400	101.0 22700	0.0785	5500	6400	0.895 1.973	0.110 0.243	
NUP210E.TVP	50 1.9685	90 3.5433	20 0.7874	1.1 0.04	1.1 0.04	59.5 2.34	81.5 3.21	64.1 2.52	77.4 3.05				74.5 16700	67.7 15200	0.0778	5500	6600	0.490 1.080		
NU2210E.TVP	50 1.9685	90 3.5433	23 0.9055	1.1 0.04	1.1 0.04	59.5 2.34	81.5 3.21		77.4 3.05			2.2 0.09	94.1 21200	81.2 18300	0.0824	4400	5200	0.575 1.268		
NUP211E.TVP	55 2.1654	100 3.9370	21 0.8268	1.1 0.04	1.5 0.06	66.0 2.60	90.0 3.54	71.0 2.80	85.6 3.37				100.0 22500	87.2 19600	0.0862	4800	5700	0.665 1.466		
NU311E.TVP	55 2.1654	120 4.7244	29 1.1417	2.0 0.08	2.0 0.08	70.5 2.78	106.5 4.19		100.3 3.95			3.0 0.12	149.0 33500	142.0 31900	0.0628	4700	5500	1.470 3.241		
NUP212E.TVP	60 2.3622	110 4.3307	22 0.8661	1.5 0.06	1.5 0.06	72.0 2.83	100.0 3.94	77.7 3.06	95.1 3.74				109.0 24500	98.6 22200	0.0896	4500	5300	0.825 1.819		
NUP2212E.TVP	60 2.3622	110 4.3307	28 1.1024	1.5 0.06	1.5 0.06	72.0 2.83	100.0 3.94	77.7 3.06	95.1 3.74				158.0 35500	132.0 29700	0.0984	3700	4300	1.080 2.381		
NUP2213E.TVP	65 2.5591	120 4.7244	31 1.2205	1.5 0.06	1.5 0.06	78.5 3.09	108.5 4.27	84.6 3.33	103.2 4.06				188.0 42300	153.0 34400	0.0723	3500	4100	1.420 3.131		

⁽¹⁾ Max. axial displacement

NEEDLE ROLLER BEARINGS

INCH SERIES

When there is a requirement for a rolling bearing to support very high dynamic, static or even shock loads with a restricted mounting space – the needle roller bearing may give best results.

REFERENCE STANDARDS ARE:

- ANSI/ABMA Standard 18.2 – needle roller bearings – radial, inch design.
- ASTM Standard F 2246 – standard specification for bearing, roller, needle: thick outer ring with rollers and cage.
- Military Standard MS 51961 – bearing, roller, needle: thick outer ring with rollers and cage.
- ASTM Standard F2431 – standard specification for ring, bearing, inner: needle roller bearing with thick outer ring.

IDENTIFICATION

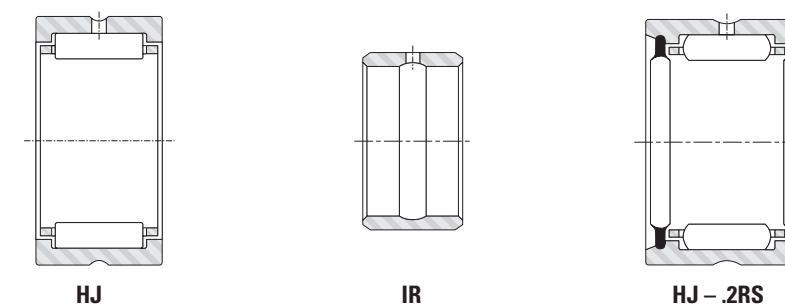

The prefix letters HJ in the needle roller bearing designation denote that the bearing is manufactured to inch nominal dimensions.

Bearings are available with one or two lip-contact seals, as listed on pages B-198 and B-199. One seal is designated by suffix letters RS. Two seals are designated by .2RS.

Inner rings can be used with HJ Series needle roller bearings for applications where it is impractical to use the shaft as the inner

raceway. These inch series inner rings are identified by the prefix letters IR.

Because the entire identification code may not appear on the bearing itself, the manufacturer's parts list or another reliable source should always be consulted when ordering bearings for service or field replacement to make certain that the correct bearing with the correct lubricant is used.

CONSTRUCTION

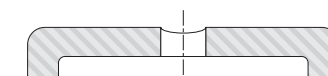

Fig. B-45. One-piece, channel-shaped outer ring



Fig. B-46. Steel cage

The HJ Series needle roller bearing has a one-piece channel-shaped outer ring of bearing-quality steel heat treated to provide maximum load rating. The integral end flanges provide axial location for the needle rollers. The bores of the end flanges serve as piloting surfaces for the cage, locating it to prevent removal of the lubricant film on the raceway.

These bearings have a steel cage, which provides inward retention for the needle rollers. The design assures roller stability and minimizes friction between the cage and the needle rollers. The cage has a maximum strength consistent with the inherent high load ratings of needle roller bearings.

The needle rollers are made from high-carbon chrome steel, through-hardened, ground and lapped to close tolerance with controlled contour for optimum load distribution.

SEALS

Shaft contact seals, which fit into the same housing bore as the heavy-duty needle roller bearings, may be obtained from recognized seal manufacturers. Bearings can also be made available with one or two integral seals. For information and listing of sealed bearings, see pages B-198 and B-199.



LUBRICATION

The outer rings of the HJ bearings are supplied with a lubrication groove on the O.D. and a lubrication hole in this groove to facilitate re-lubrication through the outer ring. The IR inner rings have lubrication grooves in the bore and a re-lubrication hole to facilitate re-lubrication through the inner ring.

HJ Series bearings (with or without seals) are typically shipped protected with a corrosion-preventive compound that is not a lubricant. When specified by the customer, HJ Series bearings may be ordered prelubricated with suitable greases and oils.

MOUNTING DIMENSIONS

HJ needle roller bearings are normally mounted in their housings with a clearance fit if the load is stationary relative to the housing, and with a tight transition fit if the load rotates relative to the housing. Because the tight transition fit of the bearing in its housing may result in a reduction of the needle roller complement bore diameter, the shaft raceway diameter should be reduced to a like amount.

The mounting dimensions in the bearing tables (pages B-194 to B-199) list the suggested ISO H7 tolerances for the housing bore and the suggested ISO h6 tolerances for the shaft raceway when the outer ring is to be mounted with a clearance fit. The tables also list the suggested ISO N7 tolerances for the housing bore and the suggested ISO f6 tolerances for the shaft raceway when the outer ring is to be mounted with a tight transition fit.

Other mounting dimensions may be required for special conditions such as:

1. Extremely heavy radial loads.
2. Shock loads.
3. Load rotating relative to both inner and outer rings.
4. Temperature gradient across bearing.
5. Housing with heat expansion coefficient differing from that of the bearing.

If these conditions are expected, please consult your representative.

DIMENSIONAL ACCURACY, BEARINGS

HJ SERIES

Tolerances for the HJ bearings are given in Tables B-25 and B-26. Pages B-194 to B-199 list the nominal outer diameter, width and needle roller complement bore diameter for the HJ bearings.

Table B-25. Outer diameter and width tolerances, HJ bearings

D				Deviation from nominal							
Nominal outer diameter				of single mean outer diameter, $D_{mp}^{(1)}$				of width, C			
>	≤	>	≤	Max.	Min.	Max.	Min.	Max.	Min.	Max.	Min.
mm	mm	in	in	mm	mm	in	in	mm	mm	in	in
19.050	50.800	0.7500	2.0000	+0	-0.013	+0	-0.0005	+0	-0.013	+0	-0.005
50.800	82.550	2.0000	3.2500	+0	-0.015	+0	-0.0006	+0	-0.013	+0	-0.005
82.550	120.650	3.2500	4.7500	+0	-0.020	+0	-0.0008	+0	-0.013	+0	-0.005

⁽¹⁾ "Single mean diameter" is defined as the mean diameter in a single radial plane.

Table B-26. Roller complement bore tolerance, HJ bearings

F_w				Deviation from nominal of the smallest single diameter ⁽¹⁾ of the roller complement bore, $F_m^{(1)}$			
Nominal roller complement bore diameter				Max.	Min.	Max.	Min.
>	≤	>	≤	mm	mm	in	in
mm	mm	in	in	mm	mm	in	in
12.700	15.875	0.5000	0.6250	+0.043	+0.020	+0.0017	+0.0008
15.875	28.575	0.6250	1.1250	+0.046	+0.023	+0.0018	+0.0009
28.575	41.275	1.1250	1.6250	+0.048	+0.025	+0.0019	+0.0010
41.275	47.625	1.6250	1.8750	+0.050	+0.025	+0.0020	+0.0010
47.625	69.850	1.8750	2.7500	+0.053	+0.028	+0.0021	+0.0011
69.850	76.200	2.7500	3.0000	+0.058	+0.028	+0.0023	+0.0011
76.200	101.600	3.0000	4.0000	+0.060	+0.030	+0.0024	+0.0012

⁽¹⁾ "The smallest single diameter of the roller complement bore" is defined as the diameter of the cylinder which, when used as a bearing inner ring, results in zero radial internal clearance in the bearing on at least one diameter.

DIMENSIONAL ACCURACY, INNER RINGS

IR SERIES

Tolerances for the IR inner rings are given in Tables B-27 and B-28. Pages B-200 to B-203 list the nominal outer diameter, width and bore diameter for the IR series inner rings.

Table B-27. Bore and width tolerances, IR inner rings

d				Deviation from nominal							
Nominal bore diameter				of single mean bore diameter, $d_{mp}^{(1)}$				of width, B			
>	≤	>	≤	Max.	Min.	Max.	Min.	Max.	Min.	Max.	Min.
mm	mm	in	in	mm	mm	in	in	mm	mm	in	in
7.938	19.050	0.3125	0.7500	+0	-0.010	+0	-0.0004	+0.25	+0.12	+0.010	+0.005
19.050	50.800	0.7500	2.0000	+0	-0.013	+0	-0.0005	+0.25	+0.12	+0.010	+0.005
50.800	82.550	2.0000	3.2500	+0	-0.015	+0	-0.0006	+0.25	+0.12	+0.010	+0.005

⁽¹⁾ "Single mean diameter" is defined as the mean diameter in a single radial plane.

Table B-28. Outer diameter tolerance, IR inner rings

F				Deviation from nominal of single mean outer diameter, $F_{mp}^{(1)}$			
Nominal outer diameter				Max.	Min.	Max.	Min.
>	≤	>	≤	mm	mm	in	in
mm	mm	in	in	mm	mm	in	in
12.700	15.875	0.5000	0.6250	-0.013	-0.023	-0.0005	-0.0009
15.875	25.400	0.6250	1.0000	-0.018	-0.031	-0.0007	-0.0012
25.400	28.575	1.0000	1.1250	-0.023	-0.036	-0.0009	-0.0014
28.575	34.925	1.1250	1.3750	-0.023	-0.036	-0.0009	-0.0015
34.925	47.625	1.3750	1.8750	-0.025	-0.038	-0.0010	-0.0016
47.625	76.200	1.8750	3.0000	-0.028	-0.040	-0.0011	-0.0018
76.200	95.250	3.0000	3.7500	-0.033	-0.046	-0.0013	-0.0022

⁽¹⁾ "Single mean diameter" is defined as the mean diameter in a single radial plane.

LOAD RATING FACTORS

DYNAMIC LOADS

Needle roller bearings can accommodate only radial loads.

$$P = F_r$$

P = The maximum dynamic radial load that may be applied to a needle roller bearing based on the dynamic load rating, C, given in the bearing tables. This load should be $\leq C/3$.

SPECIAL BEARINGS

For needle roller bearings with special dimensions or special features, such as split outer ring, consult your representative.

STATIC LOADS

Needle roller bearings can accommodate only radial loads.

$$P_0 = F_r$$



HJ TYPE

INCH SERIES

- Check for availability.
- Nominal bearing diameters and widths shown.
- Tolerance tables found on page B-192.
- Clearance fit suggested for outer ring when housing is stationary relative to load.
- Tight transition fit suggested if housing rotates relative to load.

- Consult your representative for oscillating applications (e.g., low radial clearance concerns).
- Unmarked end of outer ring should be assembled against housing shoulder to clear maximum allowed housing fillet.
- Meets Military Standard MS 51961 and ASTM F2246.

Shaft Dia.	F _w	D	C/B	r _{s min}	Bearing Designation	Used With Inner Ring Designation ⁽¹⁾	Load Ratings		Speed Rating		Approx. Wt.
							Dynamic	Static	Grease Oil		
							C	C ₀	min ⁻¹		
in	mm in	mm in	mm in	mm in			kN lbf		min ⁻¹		kg lbs
5/8	15.875 0.6250	28.575 1.1250	19.050 0.750	0.64 0.03	HJ-101812	IR-061012	19.3 4350	20.7 4650	20000	30000	0.050 0.11
3/4	19.050 0.7500	31.750 1.2500	19.050 0.750	1.02 0.04	HJ-122012	IR-081212	20.7 4650	23.3 5240	16000	25000	0.059 0.13
	19.050 0.7500	31.750 1.2500	25.400 1.000	1.02 0.04	HJ-122016	IR-081216	27.5 6190	33.7 7580	16000	25000	0.077 0.17
7/8	22.225 0.8750	34.925 1.3750	19.050 0.750	1.02 0.04	HJ-142212	IR-101412	23 5180	27.9 6270	13000	21000	0.064 0.14
	22.225 0.8750	34.925 1.3750	25.400 1.000	1.02 0.04	HJ-142216	IR-101416	30.7 6910	40.3 9070	13000	21000	0.086 0.19
1	25.400 1.0000	38.100 1.5000	19.050 0.750	1.02 0.04	HJ-162412	IR-121612	25.3 5680	32.5 7300	12000	18000	0.073 0.16
	25.400 1.0000	38.100 1.5000	25.400 1.000	1.02 0.04	HJ-162416	IR-121616 IR-131616	33.6 7560	47.2 10600	12000	18000	0.095 0.21
1 1/8	28.575 1.1250	41.275 1.6250	25.400 1.000	1.02 0.04	HJ-182616	IR-141816 IR-151816	36.3 8170	53.8 12100	10000	16000	0.104 0.23
	28.575 1.1250	41.275 1.6250	31.750 1.250	1.02 0.04	HJ-182620	IR-141820 IR-151820	44.9 10100	70.3 15800	10000	16000	0.132 0.29
1 1/4	31.750 1.2500	44.450 1.7500	25.400 1.000	1.02 0.04	HJ-202816	IR-162016	37.4 8410	57.4 12900	9100	14000	0.113 0.25
	31.750 1.2500	44.450 1.7500	31.750 1.250	1.02 0.04	HJ-202820	IR-162020	46.3 10400	75.2 16900	9100	14000	0.145 0.32
1 3/8	34.925 1.3750	47.625 1.8750	25.400 1.000	1.02 0.04	HJ-223016	IR-182216	39.8 8950	64.1 14400	8200	13000	0.127 0.28
	34.925 1.3750	47.625 1.8750	31.750 1.250	1.02 0.04	HJ-223020	IR-182220	49.4 11100	84.1 18900	8200	13000	0.159 0.35
1 1/2	38.100 1.5000	52.388 2.0625	25.400 1.000	1.52 0.06	HJ-243316	IR-202416	47.6 10700	72.5 16300	7600	12000	0.154 0.34
	38.100 1.5000	52.388 2.0625	31.750 1.250	1.52 0.06	HJ-243320	IR-192420 IR-202420	58.7 13200	95.2 21400	7600	12000	0.195 0.43
1 5/8	41.275 1.6250	55.563 2.1875	25.400 1.000	1.52 0.06	HJ-263516	IR-212616	48.5 10900	76.5 17200	7000	11000	0.163 0.36
	41.275 1.6250	55.563 2.1875	31.750 1.250	1.52 0.06	HJ-263520	IR-212620 IR-222620	60.1 13500	100.5 22600	7000	11000	0.209 0.46
1 3/4	44.450 1.7500	58.738 2.3125	25.400 1.000	1.52 0.06	HJ-283716	IR-232816 IR-242816	49.8 11200	81.0 18200	6400	9900	0.177 0.39

⁽¹⁾ See pages B-200 to B-203 for inch series inner rings. Order inner rings separately.

⁽²⁾ C_g factor for bearing without inner ring.

⁽³⁾ r_{a max} is equal to the minimum bearing chamfer (r_{s min}) at unmarked end.

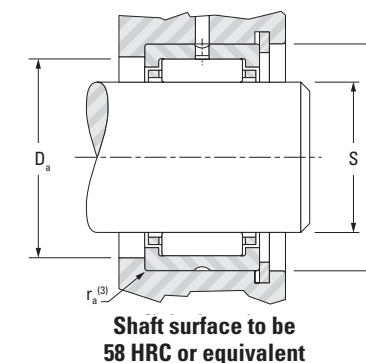
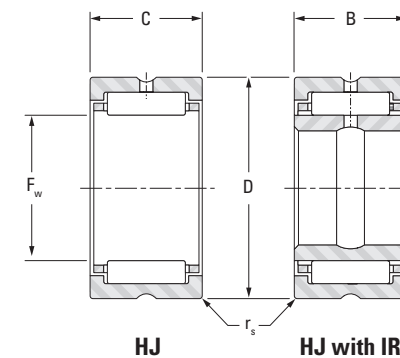

Shaft surface to be 58 HRC or equivalent

C _g ⁽²⁾	S (ISO h6)		H (ISO H7)		Bearing Designation	S (ISO f6)		H (ISO N7)		D _a Shoulder Dia. ±.015	Shaft Dia. in
	Mounting Dimension Clearance Fit					Mounting Dimension Tight Transition Fit					
	Max.	Min.	Max.	Min.		Max.	Min.	Max.	Min.		
	mm in	mm in	mm in	mm in		mm in	mm in	mm in	mm in		
0.0252	15.875 0.6250	15.865 0.6246	28.595 1.1258	28.575 1.1250	HJ-101812	15.860 0.6244	15.850 0.6240	28.567 1.1247	28.547 1.1239	23.83 0.938	5/8
0.0279	19.050 0.7500	19.037 0.7495	31.775 1.2510	31.750 1.2500	HJ-122012	19.030 0.7492	19.017 0.7487	31.742 1.2497	31.717 1.2487	26.97 1.062	3/4
0.0305	19.050 0.7500	19.037 0.7495	31.775 1.2510	31.750 1.2500	HJ-122016	19.030 0.7492	19.017 0.7487	31.742 1.2497	31.717 1.2487	26.97 1.062	
0.0310	22.225 0.8750	22.212 0.8745	34.950 1.3760	34.925 1.3750	HJ-142212	22.205 0.8742	22.192 0.8737	34.917 1.3747	34.892 1.3737	30.18 1.188	7/8
0.0340	22.225 0.8750	22.212 0.8745	34.950 1.3760	34.925 1.3750	HJ-142216	22.205 0.8742	22.192 0.8737	34.917 1.3747	34.892 1.3737	30.18 1.188	
0.0340	25.400 1.0000	25.387 0.9995	38.125 1.5010	38.100 1.5000	HJ-162412	25.380 0.9992	25.367 0.9987	38.092 1.4997	38.067 1.4987	33.32 1.312	1
0.0373	25.400 1.0000	25.387 0.9995	38.125 1.5010	38.100 1.5000	HJ-162416	25.380 0.9992	25.367 0.9987	38.092 1.4997	38.067 1.4987	33.32 1.312	
0.0404	28.575 1.1250	28.562 1.1245	41.300 1.6260	41.275 1.6250	HJ-182616	28.555 1.1242	28.542 1.1237	41.267 1.6247	41.242 1.6237	36.53 1.438	1 1/8
0.0433	28.575 1.1250	28.562 1.1245	41.300 1.6260	41.275 1.6250	HJ-182620	28.555 1.1242	28.542 1.1237	41.267 1.6247	41.242 1.6237	36.53 1.438	
0.0430	31.750 1.2500	31.735 1.2494	44.475 1.7510	44.450 1.7500	HJ-202816	31.725 1.2490	31.709 1.2484	44.442 1.7497	44.417 1.7487	39.67 1.562	1 1/4
0.0460	31.750 1.2500	31.735 1.2494	44.475 1.7510	44.450 1.7500	HJ-202820	31.725 1.2490	31.709 1.2484	44.442 1.7497	44.417 1.7487	39.67 1.562	
0.0460	34.925 1.3750	34.910 1.3744	47.650 1.8760	47.625 1.8750	HJ-223016	34.900 1.374	34.884 1.3734	47.617 1.8747	47.592 1.8737	42.88 1.688	1 3/8
0.0492	34.925 1.3750	34.910 1.3744	47.650 1.8760	47.625 1.8750	HJ-223020	34.900 1.3740	34.884 1.3734	47.617 1.8747	47.592 1.8737	42.88 1.688	
0.0480	38.100 1.5000	38.085 1.4994	52.418 2.0637	52.388 2.0625	HJ-243316	38.075 1.4990	38.059 1.4984	52.380 2.0622	52.349 2.0610	47.63 1.875	1 1/2
0.0514	38.100 1.5000	38.085 1.4994	52.418 2.0637	52.388 2.0625	HJ-243320	38.075 1.4990	38.059 1.4984	52.380 2.0622	52.349 2.0610	47.63 1.875	
0.0503	41.275 1.6250	41.260 1.6244	55.593 2.1887	55.563 2.1875	HJ-263516	41.250 1.6240	41.234 1.6234	55.555 2.1872	55.524 2.1860	50.80 2.000	1 5/8
0.0539	41.275 1.6250	41.260 1.6244	55.593 2.1887	55.563 2.1875	HJ-263520	41.250 1.6240	41.234 1.6234	55.555 2.1872	55.524 2.1860	50.80 2.000	
0.0527	44.450 1.7500	44.435 1.7494	58.768 2.3137	58.738 2.3125	HJ-283716	44.425 1.7490	44.409 1.7484	58.730 2.3122	58.699 2.3110	53.98 2.125	1 3/4

Continued on next page.



HJ TYPE – continued

INCH SERIES

- Check for availability.
- Nominal bearing diameters and widths shown.
- Tolerance tables found on page B-192.
- Clearance fit suggested for outer ring when housing is stationary relative to load.
- Tight transition fit suggested if housing rotates relative to load.

- Consult your representative for oscillating applications (e.g., low radial clearance concerns).
- Unmarked end of outer ring should be assembled against housing shoulder to clear maximum allowed housing fillet ($r_{a \max}^{(3)}$).
- Meets Military Standard MS 51961 and ASTM F2246.

Shaft Dia.	F _w	D	C/B	r _{s min}	Bearing Designation	Used With Inner Ring Designation ⁽¹⁾	Load Ratings		Speed Rating		Approx. Wt.	
							Dynamic	Static	Grease			Oil
							C	C ₀	min ⁻¹			
1 3/4	44.450 1.7500	58.738 2.3125	31.750 1.250	1.52 0.06	HJ-283720	IR-222820 IR-232820 IR-253820	61.8 13900	106 23900	6400	9900	0.222 0.49	
1 7/8	47.625 1.8750	61.913 2.4375	31.750 1.250	1.52 0.06	HJ-303920	IR-253020	65.4 14700	117 26300	6000	9200	0.236 0.52	
2	50.800 2.0000	65.088 2.5625	25.400 1.000	1.52 0.06	HJ-324116	IR-273216	53.8 12100	93.0 20900	5600	8600	0.200 0.44	
	50.800 2.0000	65.088 2.5625	31.750 1.250	1.52 0.06	HJ-324120	IR-243220 IR-253220 IR-263220 IR-273220	66.7 15000	122 27500	5600	8600	0.249 0.55	
2 1/4	57.150 2.2500	76.200 3.0000	38.100 1.500	1.52 0.06	HJ-364824	IR-283624	89.9 20200	164 36900	5000	7600	0.458 1.01	
	57.150 2.2500	76.200 3.0000	44.450 1.750	1.52 0.06	HJ-364828	IR-283628	104 23400	198 44500	5000	7600	0.531 1.17	
2 1/2	63.500 2.5000	82.550 3.2500	38.100 1.500	2.03 0.08	HJ-405224	IR-314024 IR-324024	97.0 21800	187 42100	4400	6800	0.499 1.10	
	63.500 2.5000	82.550 3.2500	44.450 1.750	2.03 0.08	HJ-405228	IR-314028 IR-324028	97.0 25200	187 50800	4400	6800	0.499 1.29	
2 3/4	69.850 2.7500	88.900 3.5000	25.400 1.000	2.03 0.08	HJ-445616	—	67.2 15100	120 27000	4000	6200	0.363 0.80	
	69.850 2.7500	88.900 3.5000	38.100 1.500	2.03 0.08	HJ-445624	IR-364424	101 22700	203 45700	4000	6200	0.544 1.20	
	69.850 2.7500	88.900 3.5000	44.450 1.750	2.03 0.08	HJ-445628	IR-354428 IR-364428	117 26300	245 55100	4000	6200	0.635 1.40	
3	76.200 3.0000	95.250 3.7500	38.100 1.500	2.03 0.08	HJ-486024	IR-404824	107 24100	226 50900	3700	5600	0.585 1.29	
	76.200 3.0000	95.250 3.7500	44.450 1.750	2.03 0.08	HJ-486028	IR-384828 IR-404828	124 27900	273 61400	3700	5600	0.685 1.51	
3 1/4	82.550 3.2500	107.950 4.2500	44.450 1.750	2.03 0.08	HJ-526828	IR-445228	162 36400	305 68600	3400	5300	1.016 2.24	
	82.550 3.2500	107.950 4.2500	50.800 2.000	2.03 0.08	HJ-526832	IR-445232	184 41300	358 80500	3400	5300	1.161 2.56	
3 1/2	88.900 3.5000	114.300 4.5000	50.800 2.000	2.03 0.08	HJ-567232	IR-475632 IR-485632	187 42000	375 84300	3200	4900	1.238 2.73	

⁽¹⁾ See pages B-200 to B-203 for inch series inner rings. Order inner rings separately.

⁽²⁾ C_g factor for bearing without inner ring.

⁽³⁾ r_{a max} is equal to the minimum bearing chamfer (r_{s min}) at unmarked end.

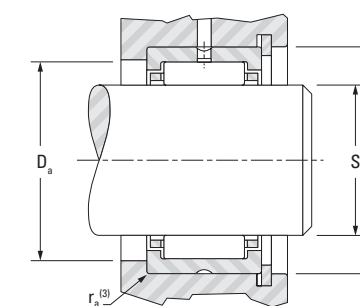
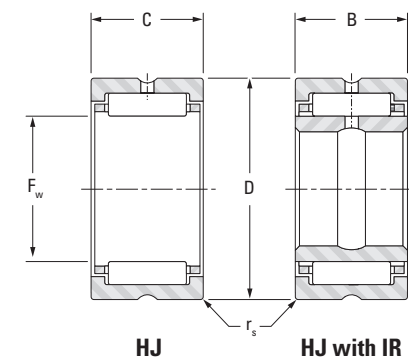

Shaft surface to be 58 HRC or equivalent

C _g ⁽²⁾	S (ISO h6)		H (ISO H7)		Bearing Designation	S (ISO f6)		H (ISO N7)		Shoulder Dia. ±.38 ±.015	Shaft Dia. in
	Mounting Dimension Clearance Fit					Mounting Dimension Tight Transition Fit					
	Max.	Min.	Max.	Min.		Max.	Min.	Max.	Min.		
	mm in	mm in	mm in	mm in		mm in	mm in	mm in	mm in		
0.0564	44.450 1.7500	44.435 1.7494	58.768 2.3137	58.738 2.3125	HJ-283720	44.425 1.7490	44.409 1.7484	58.730 2.3122	58.699 2.3110	53.98 2.125	
0.0595	47.625 1.8750	47.610 1.8744	61.943 2.4387	61.913 2.4375	HJ-303920	47.600 1.8740	47.584 1.8734	61.905 2.4372	61.874 2.4360	57.15 2.250	1 7/8
0.0578	50.800 2.0000	50.782 1.9993	65.118 2.5637	65.088 2.5625	HJ-324116	50.770 1.9988	50.752 1.9981	65.080 2.5622	65.049 2.5610	60.33 2.375	
0.0618	50.800 2.0000	50.782 1.9993	65.118 2.5637	65.088 2.5625	HJ-324120	50.770 1.9988	50.752 1.9981	65.080 2.5622	65.049 2.5610	60.33 2.375	2
0.0683	57.150 2.2500	57.132 2.2493	76.230 3.0012	76.200 3.0000	HJ-364824	57.120 2.2488	57.102 2.2481	76.192 2.9997	76.162 2.9985	68.28 2.688	2 1/4
0.0715	57.150 2.2500	57.132 2.2493	76.230 3.0012	76.200 3.0000	HJ-364828	57.120 2.2488	57.102 2.2481	76.192 2.9997	76.162 2.9985	68.28 2.688	
0.0739	63.500 2.5000	63.482 2.4993	82.586 3.2514	82.550 3.2500	HJ-405224	63.470 2.4988	63.452 2.4981	82.537 3.2495	82.502 3.2481	74.63 2.938	2 1/2
0.0774	63.500 2.5000	63.482 2.4993	82.586 3.2514	82.550 3.2500	HJ-405228	63.470 2.4988	63.452 2.4981	82.537 3.2495	82.502 3.2481	74.63 2.938	
0.0690	69.850 2.7500	69.832 2.7493	88.936 3.5014	88.900 3.5000	HJ-445616	69.820 2.7488	69.802 2.7481	88.887 3.4995	88.852 3.4981	80.98 3.188	
0.0786	69.850 2.7500	69.832 2.7493	88.936 3.5014	88.900 3.5000	HJ-445624	69.820 2.7488	69.802 2.7481	88.887 3.4995	88.852 3.4981	80.98 3.188	2 3/4
0.0823	69.850 2.7500	69.832 2.7493	88.936 3.5014	88.900 3.5000	HJ-445628	69.820 2.7488	69.802 2.7481	88.887 3.4995	88.852 3.4981	80.98 3.188	
0.0839	76.200 3.0000	76.182 2.9993	95.286 3.7514	95.250 3.7500	HJ-486024	76.170 2.9988	76.152 2.9981	95.237 3.7495	95.202 3.7481	87.33 3.438	3
0.0879	76.200 3.0000	76.182 2.9993	95.286 3.7514	95.250 3.7500	HJ-486028	76.170 2.9988	76.152 2.9981	95.237 3.7495	95.202 3.7481	87.33 3.438	
0.0888	82.550 3.2500	82.527 3.2491	107.986 4.2514	107.950 4.2500	HJ-526828	82.514 3.2486	82.492 3.2477	107.937 4.2495	107.902 4.2481	98.43 3.875	3 1/4
0.0924	82.550 3.2500	82.527 3.2491	107.986 4.2514	107.950 4.2500	HJ-526832	82.514 3.2486	82.492 3.2477	107.937 4.2495	107.902 4.2481	98.43 3.875	
0.0965	88.900 3.5000	88.877 3.4991	114.336 4.5014	114.300 4.5000	HJ-567232	88.864 3.4986	88.842 3.4977	114.287 4.4995	114.252 4.4981	104.78 4.125	3 1/2



SEALED HEAVY-DUTY NEEDLE ROLLER BEARINGS

INCH SERIES

- Bearing diameters and widths listed are nominal.
- For inspection purposes, see tolerance tables on page B-192.
- Available with one or two lip-contact seals designed to retain lubricant and exclude foreign material.
- Single seals are normally installed in the stamped end of bearing.

- Seals limit the bearing operating temperature between -30° C and +110° C (-25° F and +225° F).
- For operating temperature outside of the above range or if seals are exposed to unusual fluids, please consult your representative.

Shaft Dia.	F _w	D	C/B	r _{s min}	Bearing Designation		Used With Inner Ring ⁽¹⁾	Load Ratings		Speed Rating ⁽²⁾	C _g
					One Seal	Two Seals		Dynamic	Static		
								C	C ₀		
in	mm in	mm in	mm in	mm in				kN lbf	min ⁻¹		
5/8	15.875 0.6250	28.575 1.1250	25.40 1.000	0.64 0.03	HJ-101816RS	HJ-101816.2RS	—	19.3 4350	20.7 4650	12000	0.025
3/4	19.050 0.7500	31.750 1.2500	25.40 1.000	1.02 0.04	HJ-122016RS	HJ-122016.2RS	IR-081216	20.7 4650	23.3 5240	10000	0.028
7/8	22.225 0.8750	34.925 1.3750	25.40 1.000	1.02 0.04	HJ-142216RS	HJ-142216.2RS	IR-101416	23.0 5180	27.9 6270	8700	0.031
1	25.400 1.0000	38.100 1.5000	25.40 1.000	1.02 0.04	HJ-162416RS	HJ-162416.2RS	IR-121616 IR-131616	25.3 5680	32.5 7300	7600	0.034
1 1/8	28.575 1.1250	41.275 1.6250	31.75 1.250	1.02 0.04	HJ-182620RS	HJ-182620.2RS	IR-141820	36.3 8170	53.8 12100	6800	0.040
1 1/4	31.750 1.2500	44.450 1.7500	31.75 1.250	1.02 0.04	HJ-202820RS	HJ-202820.2RS	IR-162020	37.4 8410	57.4 12900	6100	0.043
1 3/8	34.925 1.3750	47.625 1.8750	31.75 1.250	1.02 0.04	HJ-223020RS	HJ-223020.2RS	IR-182220	39.8 8950	64.1 14400	5600	0.046
1 1/2	38.100 1.5000	52.388 2.0625	31.75 1.250	1.52 0.06	HJ-243320RS	HJ-243320.2RS	IR-192420	47.6 10700	72.5 16300	5100	0.0480
1 5/8	41.275 1.6250	55.563 2.1875	31.75 1.250	1.52 0.06	HJ-263520RS	HJ-263520.2RS	IR-212620	48.5 10900	76.5 17200	2400	0.050
1 3/4	44.450 1.7500	58.738 2.3125	31.75 1.250	1.52 0.06	HJ-283720RS	HJ-283720.2RS	IR-222820 IR-232820 IR-242820	49.8 11200	81.0 18200	4400	0.053
2	50.800 2.0000	65.088 2.5625	31.75 1.250	1.52 0.06	HJ-324120RS	HJ-324120.2RS	IR-243220 IR-253220 IR-263220 IR-273220	53.8 12100	93.0 20900	3800	0.058
2 1/4	57.150 2.2500	76.200 3.0000	44.45 1.750	1.52 0.06	HJ-364828RS	HJ-364828.2RS	IR-283628	89.9 20200	164.1 36900	1700	0.068
2 1/2	63.500 2.5000	82.550 3.2500	44.45 1.750	2.03 0.08	HJ-405228RS	HJ-405228.2RS	IR-314028 IR-324028	97.0 21800	187.3 42100	3100	0.074
2 3/4	69.850 2.7500	88.900 3.5000	44.45 1.750	2.03 0.08	HJ-445628RS	HJ-445628.2RS	IR-354428 IR-364428	101.0 22700	203.3 45700	1400	0.079
3	76.200 3.0000	95.250 3.7500	44.45 1.750	2.03 0.08	HJ-486028RS	HJ-486028.2RS	IR-384828 IR-404828	107.2 24100	226.4 50900	2500	0.084

⁽¹⁾ See pages B-200 to B-203 for inch series inner rings. Order inner rings separately.

⁽²⁾ Based on standard seal shaft contact speed of 5 m/sec., 1000 ft./min.

⁽³⁾ r_{a max} is equal to the minimum bearing chamfer (r_{s min}) at unmarked end.

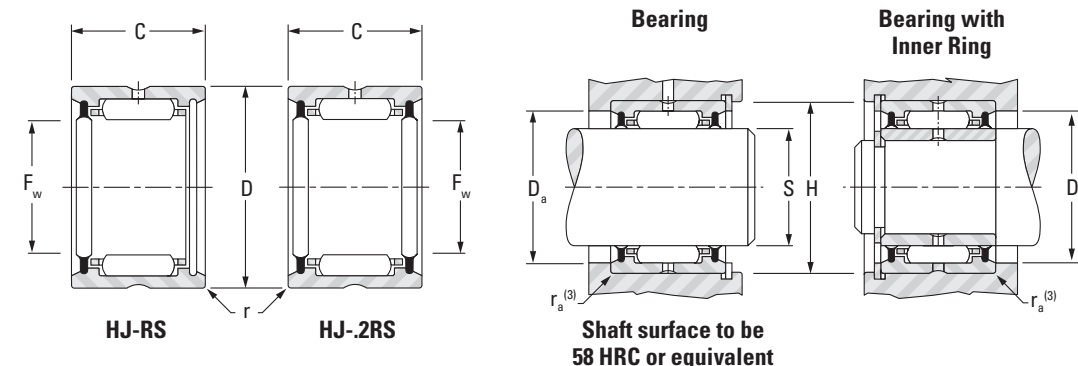

Approx. Wt.	S (ISO h6)		H (ISO H7)		Bearing Designation	S (ISO f6)		H (ISO N7)		D _a Shoulder Dia. ±.38 ±.015	Shaft Dia. in
	Mounting Dimension Clearance Fit					Mounting Dimension Tight Transition Fit					
	Max.	Min.	Max.	Min.		Max.	Min.	Max.	Min.		
	mm in	mm in	mm in	mm in		mm in	mm in	mm in	mm in		
0.07 0.15	15.875 0.6250	15.865 0.6246	28.595 1.1258	28.575 1.1250	HJ-101816-	15.860 0.6244	15.850 0.6240	28.567 1.1247	28.547 1.1239	23.83 0.938	5/8
0.08 0.17	19.050 0.7500	19.037 0.7495	31.775 1.2510	31.750 1.2500	HJ-122016-	19.030 0.7492	19.017 0.7487	31.742 1.2497	31.717 1.2487	26.97 1.062	3/4
0.09 0.19	22.225 0.8750	22.212 0.8745	34.950 1.3760	34.925 1.3750	HJ-142216-	22.205 0.8742	22.192 0.8737	34.917 1.3747	34.892 1.3737	30.18 1.188	7/8
0.10 0.21	25.400 1.0000	25.387 0.9995	38.125 1.5010	38.100 1.5000	HJ-162416-	25.380 0.9992	25.367 0.9987	38.092 1.4997	38.067 1.4987	33.32 1.312	1
0.13 0.29	28.575 1.1250	28.562 1.1245	41.300 1.6260	41.275 1.6250	HJ-182620-	28.555 1.1242	28.542 1.1237	41.267 1.6247	41.242 1.6237	36.53 1.438	1 1/8
0.15 0.32	31.750 1.2500	31.735 1.2494	44.475 1.7510	44.450 1.7500	HJ-202820-	31.725 1.2490	31.709 1.2484	44.442 1.7497	44.417 1.7487	39.67 1.562	1 1/4
0.16 0.35	34.925 1.3750	34.910 1.3744	47.650 1.8760	47.625 1.8750	HJ-223020-	34.900 1.3740	34.884 1.3734	47.617 1.8747	47.592 1.8737	42.88 1.688	1 3/8
0.20 0.43	38.100 1.5000	38.085 1.4994	52.418 2.0637	52.388 2.0625	HJ-243320-	38.075 1.4990	38.059 1.4984	52.380 2.0622	52.349 2.0610	47.63 1.875	1 1/2
0.21 0.46	41.275 1.6250	41.260 1.6244	55.593 2.1887	55.563 2.1875	HJ-263520-	41.250 1.6240	41.234 1.6234	55.555 2.1872	55.524 2.1860	50.80 2.000	1 5/8
0.22 0.49	44.450 1.7500	44.435 1.7494	58.768 2.3137	58.738 2.3125	HJ-283720-	44.425 1.7490	44.409 1.7484	58.730 2.3122	58.699 2.3110	53.98 2.125	1 3/4
0.25 0.55	50.800 2.0000	50.782 1.9993	65.118 2.5637	65.088 2.5625	HJ-324120-	50.770 1.9988	50.752 1.9981	65.080 2.5622	65.049 2.5610	60.33 2.375	2
0.53 1.17	57.150 2.2500	57.132 2.2493	76.230 3.0012	76.200 3.0000	HJ-364828-	57.120 2.2488	57.102 2.2481	76.192 2.9997	76.162 2.9985	68.28 2.688	2 1/4
0.59 1.29	63.500 2.5000	63.482 2.4993	82.586 3.2514	82.550 3.2500	HJ-405228-	63.470 2.4988	63.452 2.4981	82.537 3.2495	82.502 3.2481	74.63 2.938	2 1/2
0.64 1.40	69.850 2.7500	69.832 2.7493	88.936 3.5014	88.900 3.5000	HJ-445628-	69.820 2.7488	69.802 2.7481	88.887 3.4995	88.852 3.4981	80.98 3.188	2 3/4
0.68 1.51	76.200 3.0000	76.182 2.9993	95.286 3.7514	95.250 3.7500	HJ-486028-	76.170 2.9988	76.152 2.9981	95.237 3.7495	95.202 3.7481	87.33 3.438	3



INNER RINGS

INCH SERIES

- Check for availability.
- Ideal choice when shaft is not practical to use as inner raceway.
- Provided in inch nominal dimensions for use with inch series heavy-duty needle roller bearings.
- Designed to meet established inch tolerances.
- Selected size should be wider than matching needle roller bearing.

- Maximum shaft fillet radius ($r_{as\ max}$) cannot exceed inner ring bore chamfer ($r_{s\ min}$) as shown.
- Optional centralized lubrication groove (bore) or through-hole available. Specify when ordering.
- Designed to be axially clamped against shoulder for loose transition fit on shaft.
- After mounting, for tight transition fit (keeping inner ring from rotating relative to shaft), inner ring O.D. must not exceed raceway diameter on matching bearing. (See mounting

Shaft Dia.	d	F	B	$r_{s\ min}$	Bearing Designation	Approx. Wt.	S		S		Used With Bearing Designation
							Loose Transition Fit		Interference Fit		
							Max.	Min.	Max.	Min.	
in	mm in	mm in	mm in	mm in		kg lbs	mm in	mm in	mm in	mm in	
³ / ₈	9.525 0.3750	15.875 0.6250	19.05 0.750	0.64 0.025	IR-061012	0.018 0.040	9.520 0.3748	9.510 0.3744	9.538 0.3755	9.530 0.3752	HJ-101812
¹ / ₂	12.700 0.5000	19.050 0.7500	19.05 0.750	1.02 0.04	IR-081212	0.023 0.050	12.692 0.4997	12.682 0.4993	12.715 0.5006	12.708 0.5003	HJ-122012
	12.700 0.5000	19.050 0.7500	25.40 1.000	1.02 0.04	IR-081216	0.032 0.070	12.692 0.4997	12.682 0.4993	12.715 0.5006	12.708 0.5003	HJ-122016
⁵ / ₈	15.875 0.6250	22.225 0.8750	19.05 0.750	1.02 0.04	IR-101412	0.027 0.060	15.867 0.6247	15.857 0.6243	15.890 0.6256	15.883 0.6253	HJ-142212
	15.875 0.6250	22.225 0.8750	25.40 1.000	1.02 0.04	IR-101416	0.036 0.080	15.867 0.6247	15.857 0.6243	15.890 0.6256	15.883 0.6253	HJ-142216
¹¹ / ₁₆	17.463 0.6875	22.225 0.8750	19.05 0.750	1.02 0.04	IR-111412	0.023 0.050	17.455 0.6872	17.445 0.6868	17.478 0.6881	17.470 0.6878	HJ-142212
	19.050 0.7500	25.400 1.0000	19.05 0.750	1.02 0.04	IR-121612	0.032 0.070	19.042 0.7497	19.030 0.7492	19.068 0.7507	19.058 0.7503	HJ-162412
¹³ / ₁₆	19.050 0.7500	25.400 1.0000	25.40 1.000	1.02 0.04	IR-121616	0.041 0.090	19.042 0.7497	19.030 0.7492	19.068 0.7507	19.058 0.7503	HJ-162416
	20.638 0.8125	25.400 1.0000	25.40 1.000	1.02 0.04	IR-131616	0.032 0.070	20.630 0.8122	20.617 0.8117	20.655 0.8132	20.645 0.8128	HJ-162416
⁷ / ₈	22.225 0.8750	28.575 1.1250	25.40 1.000	1.02 0.04	IR-141816	0.050 0.110	22.217 0.8747	22.205 0.8742	22.243 0.8757	22.233 0.8753	HJ-182616
	22.225 0.8750	28.575 1.1250	31.75 1.250	1.02 0.04	IR-141820	0.059 0.130	22.217 0.8747	22.205 0.8742	22.243 0.8757	22.233 0.8753	HJ-182620
¹⁵ / ₁₆	23.813 0.9375	28.575 1.1250	25.40 1.000	1.02 0.04	IR-151816	0.036 0.080	23.805 0.9372	23.792 0.9367	23.830 0.9382	23.820 0.9378	HJ-182616
	23.813 0.9375	28.575 1.1250	31.75 1.250	1.02 0.04	IR-151820	0.045 0.100	23.805 0.9372	23.792 0.9367	23.830 0.9382	23.820 0.9378	HJ-182620
1	25.400 1.0000	31.750 1.2500	25.40 1.000	1.02 0.04	IR-162016	0.054 0.120	25.392 0.9997	25.380 0.9992	25.418 1.0007	25.408 1.0003	HJ-202816
	25.400 1.0000	31.750 1.2500	31.75 1.250	1.02 0.04	IR-162020	0.068 0.150	25.392 0.9997	25.380 0.9992	25.418 1.0007	25.408 1.0003	HJ-202820
^{1 1} / ₈	28.575 1.1250	34.925 1.3750	25.40 1.000	1.02 0.04	IR-182216	0.059 0.130	28.567 1.1247	28.555 1.1242	28.593 1.1257	28.583 1.1253	HJ-223016
	28.575 1.1250	34.925 1.3750	31.75 1.250	1.02 0.04	IR-182220	0.077 0.170	28.567 1.1247	28.555 1.1242	28.593 1.1257	28.583 1.1253	HJ-223020
^{1 1} / ₁₆	30.163 1.1875	38.100 1.5000	31.75 1.250	1.52 0.06	IR-192420	0.100 0.220	30.155 1.1872	30.142 1.1867	30.180 1.1882	30.170 1.1878	HJ-243320
	31.750 1.2500	38.100 1.5000	25.40 1.000	1.52 0.06	IR-202416	0.068 0.150	31.740 1.2496	31.725 1.2490	31.770 1.2508	31.760 1.2504	HJ-243316

⁽¹⁾ r_a max is equal to the minimum bearing chamfer (r_s min).

Continued on next page.

dimensions in the bearing table for the required raceway diameter.)

- After mounting, if O.D. of inner ring exceeds the required raceway diameter for matching bearing, ring should be ground to proper diameter while mounted on shaft.
- Meets ASTM F-2431.

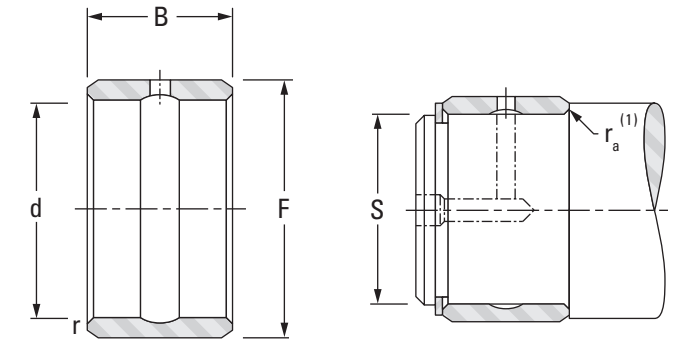

Shaft Dia.	d	F	B	$r_{s\ min}$	Bearing Designation	Approx. Wt.	S		S		Used With Bearing Designation
							Loose Transition Fit		Interference Fit		
							Max.	Min.	Max.	Min.	
in	mm in	mm in	mm in	mm in		kg lbs	mm in	mm in	mm in	mm in	
^{1 1} / ₄	31.750 1.2500	38.100 1.5000	31.75 1.250	1.52 0.06	IR-202420	0.082 0.180	31.740 1.2496	31.725 1.2490	31.770 1.2508	31.760 1.2504	HJ-243320
^{1 5} / ₁₆	33.338 1.3125	41.275 1.6250	25.40 1.000	1.52 0.06	IR-212616	0.086 0.190	33.327 1.3121	33.312 1.3115	33.358 1.3133	33.348 1.3129	HJ-263516
	33.338 1.3125	41.275 1.6250	31.75 1.250	1.52 0.06	IR-212620	0.109 0.240	33.327 1.3121	33.312 1.3115	33.358 1.3133	33.348 1.3129	HJ-263520
^{1 3} / ₈	34.925 1.3750	41.275 1.6250	31.75 1.250	1.52 0.06	IR-222620	0.091 0.200	34.915 1.3746	34.900 1.3740	34.945 1.3758	34.935 1.3754	HJ-263520
	34.925 1.3750	44.450 1.7500	31.75 1.250	1.52 0.06	IR-222820	0.141 0.310	34.915 1.3746	34.900 1.3740	34.945 1.3758	34.935 1.3754	HJ-283720
^{1 7} / ₁₆	36.513 1.4375	44.450 1.7500	25.40 1.000	1.52 0.06	IR-232816	0.095 0.210	36.502 1.4371	36.487 1.4365	36.533 1.4383	36.523 1.4379	HJ-283716
	36.513 1.4375	44.450 1.7500	31.75 1.250	1.52 0.06	IR-232820	0.118 0.260	36.502 1.4371	36.487 1.4365	36.533 1.4383	36.523 1.4379	HJ-283720
^{1 1} / ₂	38.100 1.5000	44.450 1.7500	25.40 1.000	1.52 0.06	IR-242816	0.077 0.170	38.090 1.4996	38.075 1.4990	38.120 1.5008	38.110 1.5004	HJ-283716
	38.100 1.5000	44.450 1.7500	31.75 1.250	1.52 0.06	IR-242820	0.095 0.210	38.090 1.4996	38.075 1.4990	38.120 1.5008	38.110 1.5004	HJ-283720
^{1 9} / ₁₆	38.100 1.5000	50.800 2.0000	31.75 1.250	1.52 0.06	IR-243220	0.209 0.460	38.090 1.4996	38.075 1.4990	38.120 1.5008	38.110 1.5004	HJ-324120
	39.688 1.5625	47.625 1.8750	31.75 1.250	1.52 0.06	IR-253020	0.127 0.280	39.677 1.5621	39.662 1.5615	39.708 1.5633	39.698 1.5629	HJ-303920
^{1 5} / ₈	39.688 1.5625	50.800 2.0000	31.75 1.250	1.52 0.06	IR-253220	0.186 0.410	39.677 1.5621	39.662 1.5615	39.708 1.5633	39.698 1.5629	HJ-324120
	41.275 1.6250	50.800 2.0000	31.75 1.250	1.52 0.06	IR-263220	0.163 0.360	41.265 1.6246	41.250 1.6240	41.295 1.6258	41.285 1.6254	HJ-324120
^{1 11} / ₁₆	42.863 1.6875	50.800 2.0000	25.40 1.000	1.52 0.06	IR-273216	0.109 0.240	42.852 1.6871	42.837 1.6865	42.883 1.6883	42.873 1.6879	HJ-324116
	42.863 1.6875	50.800 2.0000	31.75 1.250	1.52 0.06	IR-273220	0.136 0.300	42.852 1.6871	42.837 1.6865	42.883 1.6883	42.873 1.6879	HJ-324120
^{1 3} / ₄	44.450 1.7500	57.150 2.2500	38.10 1.500	1.52 0.06	IR-283624	0.286 0.630	44.440 1.7496	44.425 1.7490	44.470 1.7508	44.460 1.7504	HJ-364824
	44.450 1.7500	57.150 2.2500	44.45 1.750	1.52 0.06	IR-283628	0.336 0.740	44.440 1.7496	44.425 1.7490	44.470 1.7508	44.460 1.7504	HJ-364828
^{1 15} / ₁₆	49.213 1.9375	63.500 2.5000	38.10 1.500	2.03 0.08	IR-314024	0.358 0.790	49.202 1.9371	49.187 1.9365	49.233 1.9383	49.223 1.9379	HJ-405224
	49.213 1.9375	63.500 2.5000	44.45 1.750	2.03 0.08	IR-314028	0.417 0.920	49.202 1.9371	49.187 1.9365	49.233 1.9383	49.223 1.9379	HJ-405228

⁽¹⁾ r_a max is equal to the minimum bearing chamfer (r_s min).

Continued on next page.



INNER RINGS — *continued*

INCH SERIES

- Check for availability.
- Ideal choice when shaft is not practical to use as inner raceway.
- Provided in inch nominal dimensions for use with inch series heavy-duty needle roller bearings.
- Designed to meet established inch tolerances.
- Selected size should be wider than matching needle roller bearing.

- Maximum shaft fillet radius ($r_{a\ max}$) cannot exceed inner ring bore chamfer ($r_{s\ min}$) as shown.
- Optional centralized lubrication groove (bore) or through-hole available. Specify when ordering.
- Designed to be axially clamped against shoulder for loose transition fit on shaft.
- After mounting, for tight transition fit (keeping inner ring from rotating relative to shaft), inner ring O.D. must not exceed raceway diameter on matching bearing. (See mounting

Shaft Dia.	d	F	B	$r_{s\ min}$	Bearing Designation	Approx. Wt.	S		S		Used With Bearing Designation
							Loose Transition Fit		Interference Fit		
							Max.	Min.	Max.	Min.	
in	mm in	mm in	mm in	mm in	kg lbs	mm in	mm in	mm in	mm in		
2	50.800 2.0000	63.500 2.5000	38.10 1.500	2.03 0.08	IR-324024	0.322 0.710	50.790 1.9996	50.772 1.9989	50.823 2.0009	50.810 2.0004	HJ-405224
	50.800 2.0000	63.500 2.5000	44.45 1.750	2.03 0.08	IR-324028	0.376 0.830	50.790 1.9996	50.772 1.9989	50.823 2.0009	50.810 2.0004	HJ-405228
2 3/16	55.563 2.1875	69.850 2.7500	44.45 1.750	2.03 0.08	IR-354428	0.467 1.030	55.552 2.1871	55.535 2.1864	55.585 2.1884	55.573 2.1879	HJ-445628
2 1/4	57.150 2.2500	69.850 2.7500	38.10 1.500	2.03 0.08	IR-364424	0.358 0.790	57.140 2.2496	57.122 2.2489	57.173 2.2509	57.160 2.2504	HJ-445624
	57.150 2.2500	69.850 2.7500	44.45 1.750	2.03 0.08	IR-364428	0.417 0.920	57.140 2.2496	57.122 2.2489	57.173 2.2509	57.160 2.2504	HJ-445628
2 3/8	60.325 2.3750	76.200 3.0000	44.45 1.750	2.03 0.08	IR-384828	0.562 1.240	60.315 2.3746	60.297 2.3739	60.348 2.3759	60.335 2.3754	HJ-486028
2 1/2	63.500 2.5000	76.200 3.0000	38.10 1.500	2.03 0.08	IR-404824	0.395 0.870	63.490 2.4996	63.472 2.4989	63.523 2.5009	63.510 2.5004	HJ-486024
	63.500 2.5000	76.200 3.0000	44.45 1.750	2.03 0.08	IR-404828	0.463 1.020	63.490 2.4996	63.472 2.4989	63.523 2.5009	63.510 2.5004	HJ-486028
2 3/4	69.850 2.7500	82.550 3.2500	44.45 1.750	2.03 0.08	IR-445228	0.503 1.110	69.840 2.7496	69.822 2.7489	69.873 2.7509	69.860 2.7504	HJ-526828
	69.850 2.7500	82.550 3.2500	50.80 2.000	2.03 0.08	IR-445232	0.576 1.270	69.840 2.7496	69.822 2.7489	69.873 2.7509	69.860 2.7504	HJ-526832
2 15/16	74.613 2.9375	88.900 3.5000	50.80 2.000	2.03 0.08	IR-475632	0.694 1.530	74.602 2.9371	74.585 2.9364	74.635 2.9384	74.623 2.9379	HJ-567232
3	76.200 3.0000	88.900 3.5000	50.80 2.000	2.03 0.08	IR-485632	0.621 1.370	76.190 2.9996	76.172 2.9989	76.223 3.0009	76.210 3.0004	HJ-567232

⁽¹⁾ r_a max is equal to the minimum bearing chamfer (r_s min).

- dimensions in the bearing table for the required raceway diameter).
- After mounting, if O.D. of inner ring exceeds the required raceway diameter for matching bearing, ring should be ground to proper diameter while mounted on shaft.
- Meets ASTM F-2431.

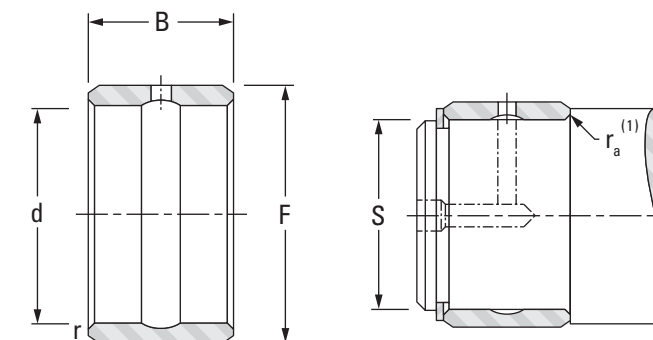



NOTES

TRACK ROLLERS

Overview: Track rollers (also known as cam followers) are characterized by their thick-walled outer rings that run directly on a track. The thick outer rings permit high load-carrying capability while minimizing both distortion and bending stresses. Sealed designs with internal thrust washers help extend service life under conditions of infrequent lubrication.

- **Sizes:** Stud-Type: 10 mm – 130 mm (0.3937 in – 5.1180 in) O.D.
Yoke-Type: 10 mm – 300 mm (0.3937 in – 11.816 in) O.D.
- **Markets:** Ram support rollers, material handling and indexing equipment.
- **Features:** Available in two basic designs: with an inner ring for straddle mounting in a yoke or with an integral stud for cantilever mounting.
- **Benefits:** High load-carrying capability with minimized distortion and bending stresses. Extended service life under conditions of infrequent re-lubrication.



Caged Yoke-Type Track Rollers – Metric Nominal Dimensions

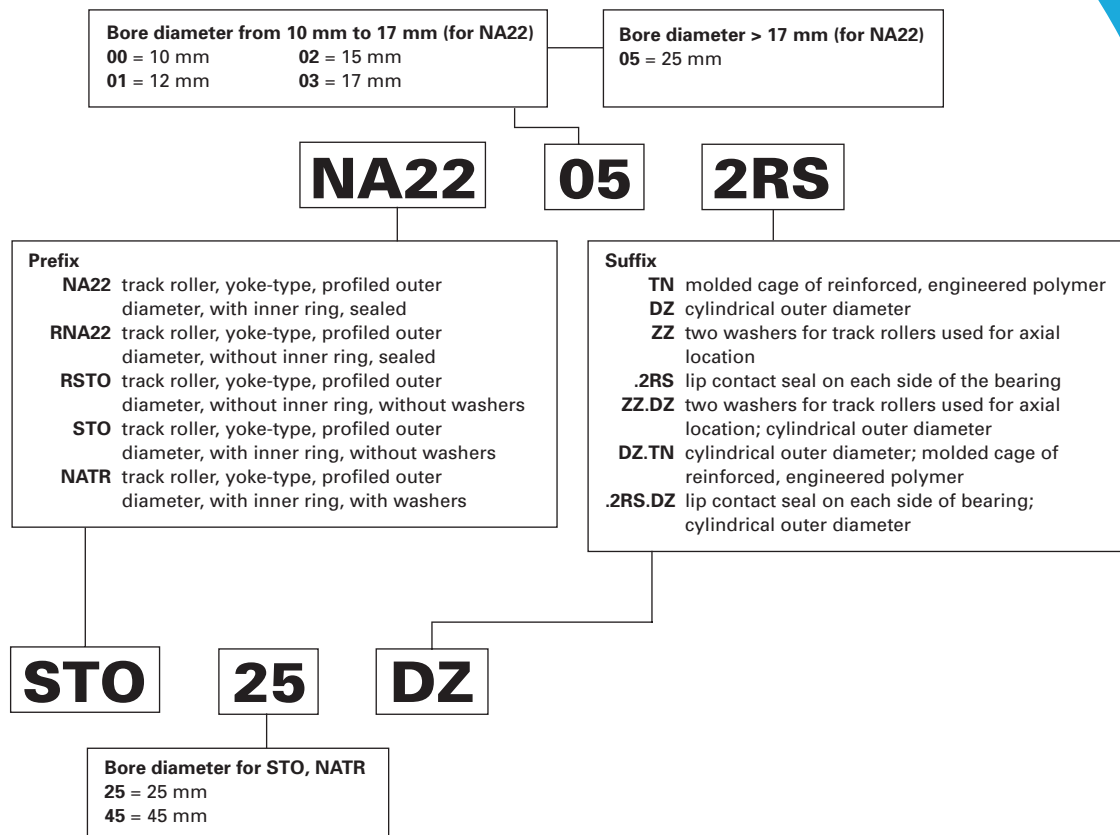

Caged Stud-Type Track Rollers – Metric Nominal Dimensions

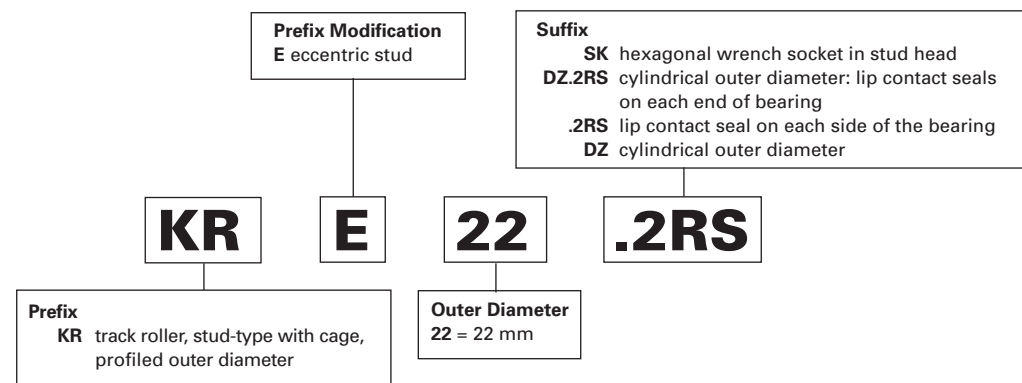

Full Complement Track Rollers – Inch Nominal Dimensions

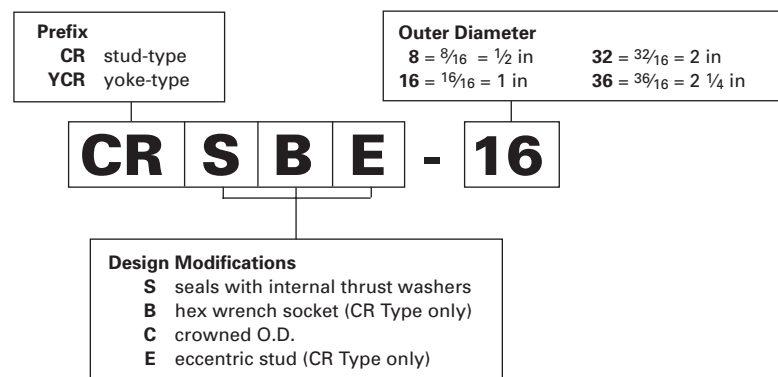

Full Complement Yoke-Type Track Rollers – Metric Nominal Dimensions

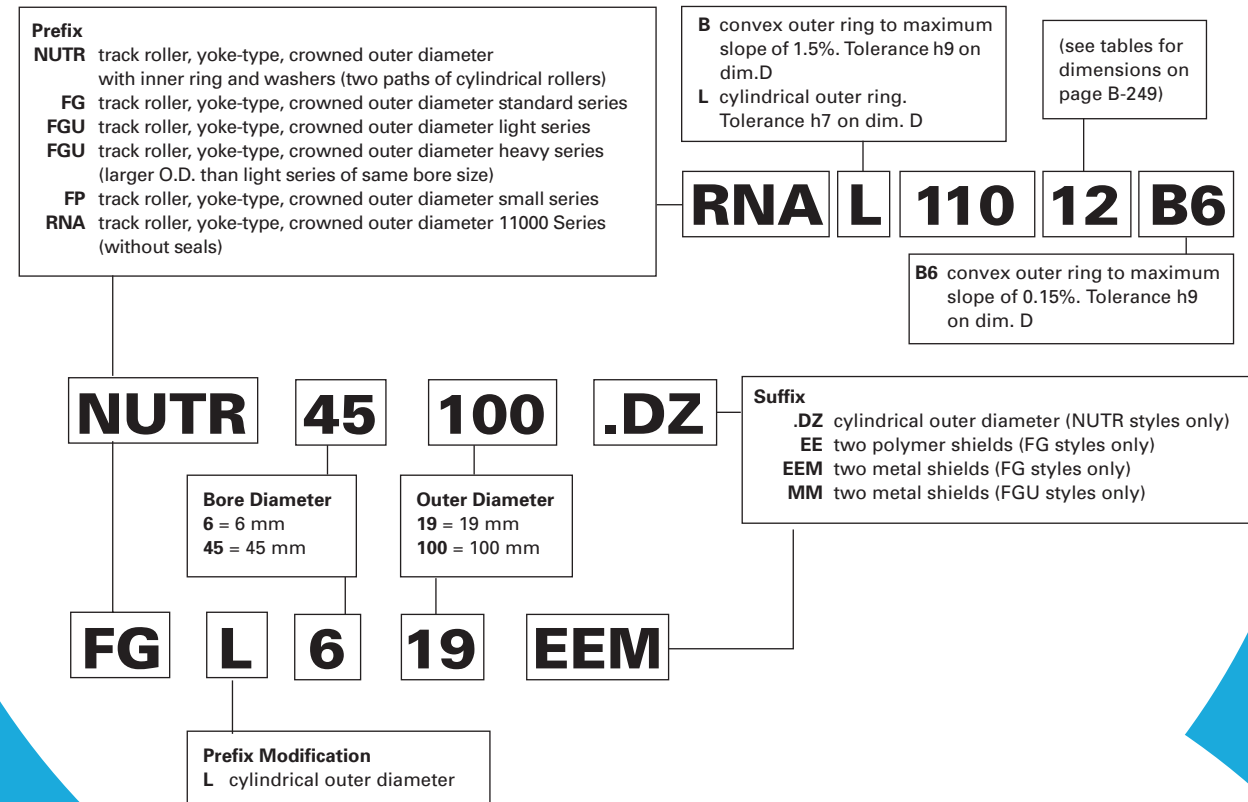

Full Complement Stud-Type Track Rollers – Metric Nominal Dimensions

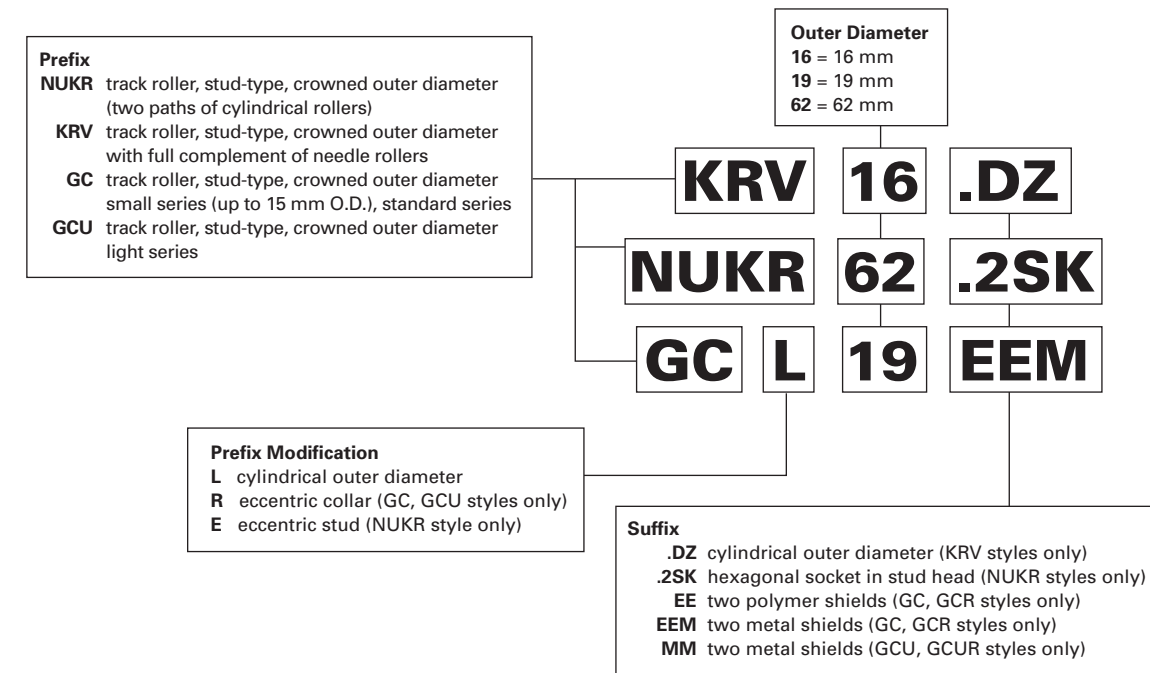

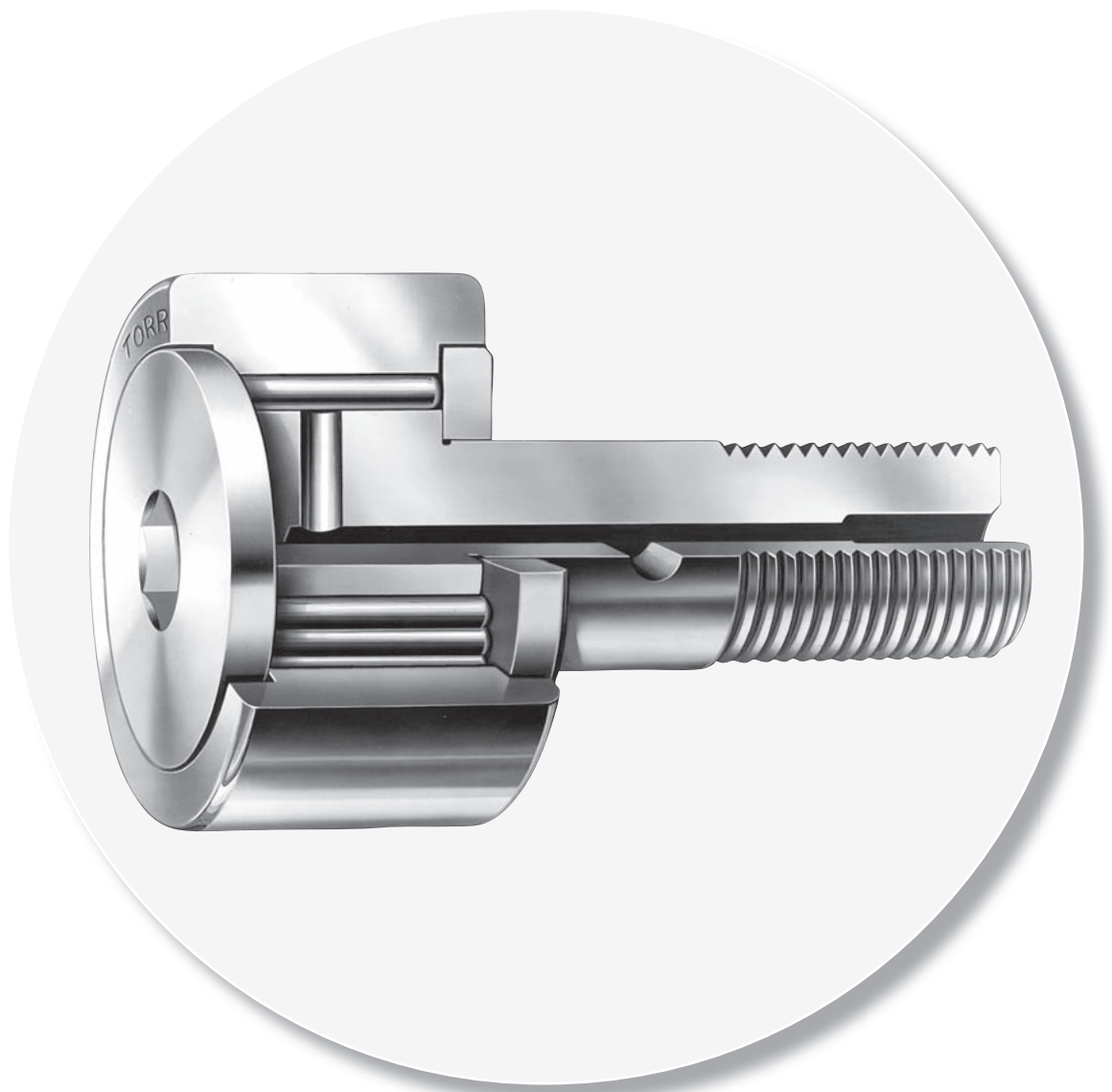

Stud-Type and Yoke-Type Track Roller

STUD-TYPE AND YOKE-TYPE TRACK ROLLERS METRIC SERIES

Introduction B-210

STUD-TYPE METRIC SERIES

Needle Roller and Cage Assemblies (KR Series) B-220

Needle Roller and Cage Assemblies, Sealed
(KR...2S Series) B-222

Full Complement with Needle Rollers (KRV Series) or
Cylindrical Rollers (NUKR Series) B-224

Full Complement, Small Series, Unsealed (GC Series) B-226

Full Complement, Standard Series, with or
without Seals (GC Series) B-228

Full Complement, with Metal Seals (GCU...MM Series) B-230

Full Complement, Eccentric (GCR Series) B-232

Full Complement, Eccentric, with Metal Seals
(GCUR...MM Series) B-234

YOKE-TYPE METRIC SERIES

Caged, without Inner Ring, No End Washers
(RSTO Series) B-236

Caged, with Inner Ring, No End Washers (STO Series) B-237

Caged, without Inner Ring, No End Washers,
Sealed (RNA22 Series) B-238

Caged, with Inner Ring, No End Washers,
Sealed (NA22 Series) B-239

Caged, with Inner Ring, with End Washers
(NATR, STO...ZZ Series) B-240

Full Complement, with Inner Ring, with End Washers,
Cylindrical Rollers (NUTR Series) B-241

Page

Page

Full Complement, Non-Separable, Small Series,
Unsealed (FP Series) B-242

Full Complement, Non-Separable, Sealed or Unsealed
(FG Series) B-243

Full Complement, Non-Separable, Light Series,
with Metal Seals (FGU...MM Series) B-245

Full Complement, Non-Separable, Heavy Series,
with Metal Seals (FGU...MM Series) B-246

Full Complement, without Inner Ring, Unsealed
(RNA...B6, RNAB, RNAL Series) B-248

Separate Inner Rings (BIC Series) B-248

STUD-TYPE AND YOKE-TYPE TRACK ROLLERS – FULL COMPLEMENT INCH SERIES

Introduction B-250

Stud-Type Track Rollers CR, CRS Series B-256

Stud-Type Track Rollers CRSB Series B-260

Yoke-Type Track Rollers YCR, YCRS Series B-264

STUD-TYPE AND YOKE-TYPE TRACK ROLLERS

METRIC SERIES

JTEKT track rollers listed in this catalog have been designed with outer rings of a large radial cross section to withstand heavy rolling and shock loads on track-type or cam-controlled equipment. The outer diameters of the outer rings are either crowned or cylindrical. Crowned track rollers are designed to alleviate uneven bearing loading resulting from deflection, bending or misalignment in mounting.

Stud-type track rollers are available in various open designs, as well as with lip contact seals or metal shields.

Yoke-type track rollers are designed for straddle mounting. The various metric series designs are grouped and organized as illustrated below.

REFERENCE STANDARDS ARE:

- **ISO 6278** – needle roller bearings – track rollers – boundary dimensions.
- **ISO 492** – radial bearings – tolerances.
- **DIN 620** – tolerances of ball and roller bearings.
- **ISO 281** – rolling bearings – dynamic load ratings and rating life.



Fig. B-48. Yoke-type track rollers

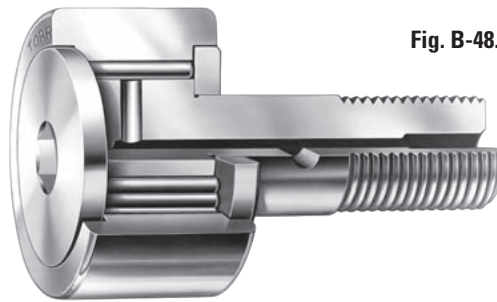

Fig. B-47. Stud-type track rollers

Suffixes – Stud-Type, Metric Series (except GC types)

.2RS	two seals
DZ	cylindrical outer diameter
DZ.2RS	cylindrical outer diameter • two seals
SK	hexagonal socket in flange end
2SK	hexagonal socket in both flange and stud ends

Suffixes – Yoke-Type, Metric Series (except FP or FG types)

DZ.TN	cylindrical outer diameter • molded cage of reinforced engineered polymer
TN	molded cage of reinforced engineered polymer
DZ	cylindrical outer diameter
ZZ	two end washers for the outer ring
ZZ.DZ	two end washers for the outer ring • cylindrical outer diameter
.2RS	two seals
.2RS.DZ	two seals • cylindrical outer diameter

Suffixes – Yoke-Type (FP, FG) and Stud-Type (GC)

EE	polymer shields
EEM	metal shields
MM	metal shields

STUD-TYPE METRIC SERIES TRACK ROLLER TYPES

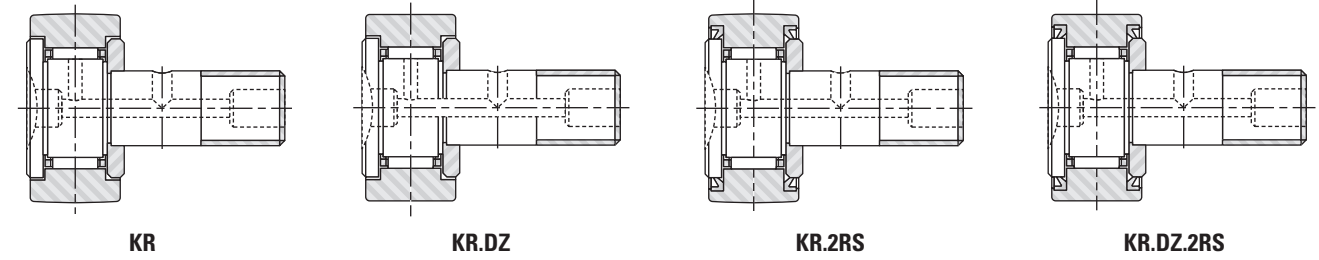

Fig. B-49. Stud-type track rollers, caged needle rollers

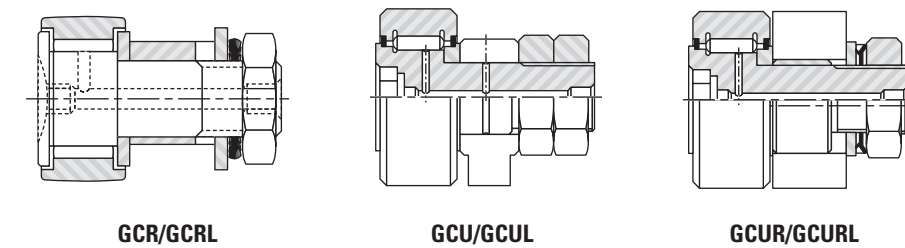
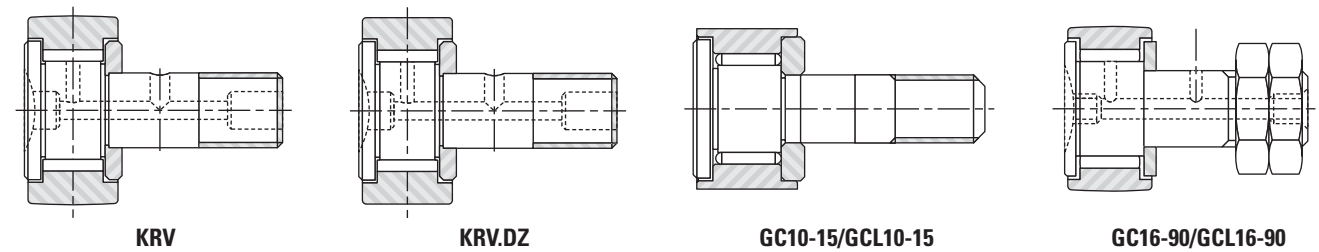

Fig. B-50. Stud-type track rollers, full complement needle rollers

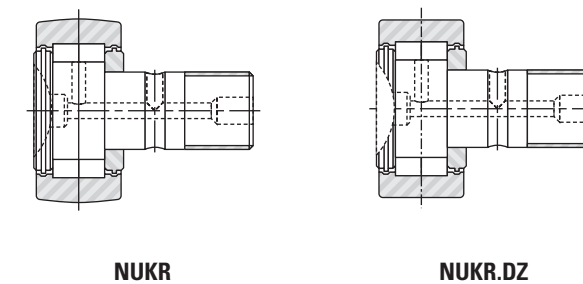

Fig. B-51. Stud-type track rollers, full complement cylindrical rollers

TYPES OF METRIC SERIES YOKE-TYPE TRACK ROLLERS

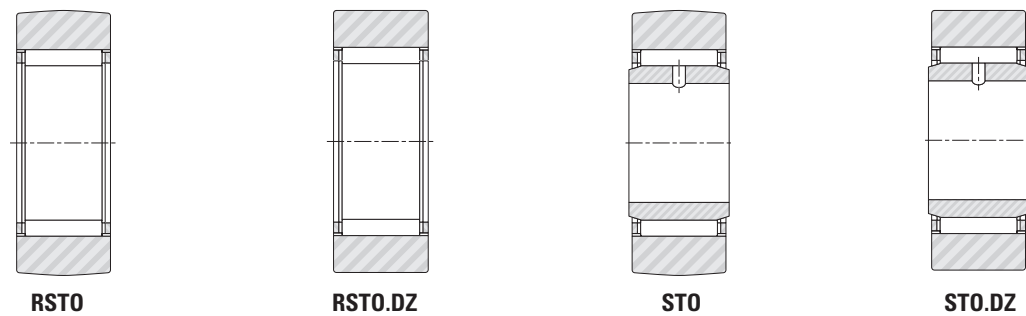

Fig. B-52. Yoke-type track rollers without end washers

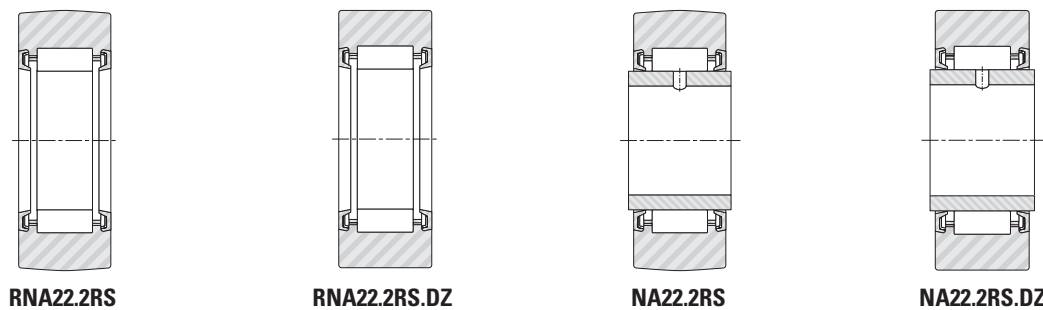

Fig. B-53. Sealed yoke-type track rollers without end washers

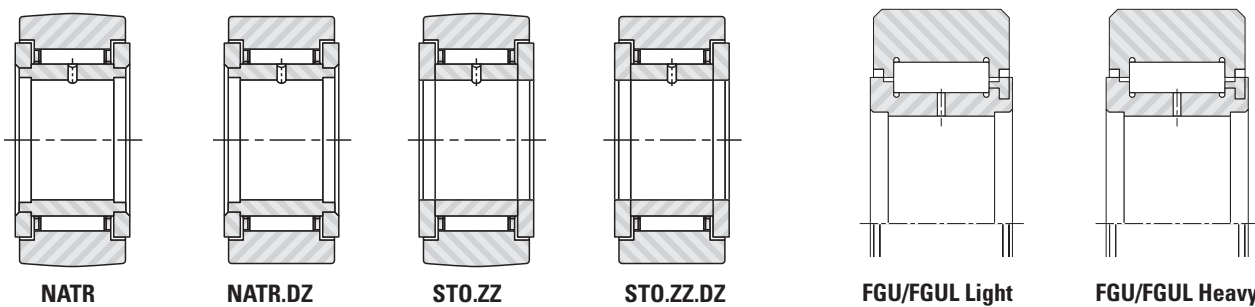

Fig. B-54. Yoke-type track rollers with end washers

Fig. B-55. Yoke-type track rollers with metal seals, full complement of cylindrical rollers

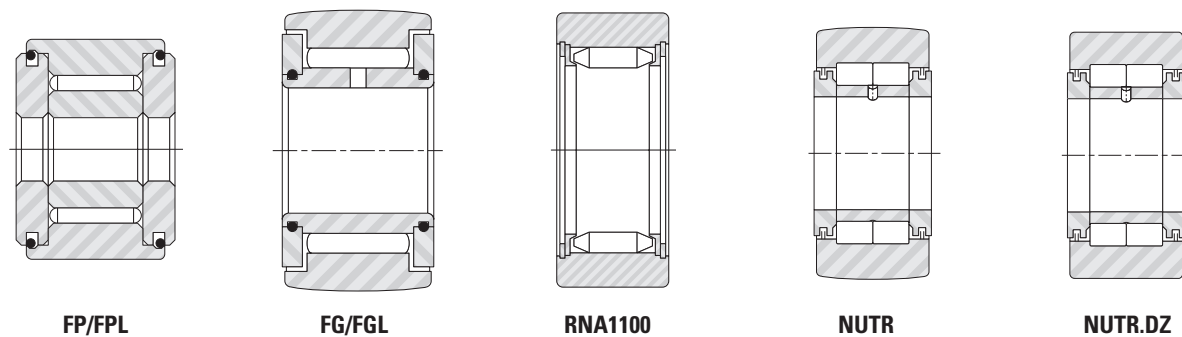

Fig. B-56-1. Yoke-type track rollers with end washers, full complement of needle rollers

Fig. B-56-2. Yoke-type track rollers with end washers, full complement of cylindrical rollers

CONSTRUCTION
STUD-TYPE TRACK ROLLERS

The metric series stud-type track roller is a non-separable unit – consisting of a large radial cross section outer ring, radial needle roller and cage assembly, or a full complement of needle or cylindrical rollers, a stud and a retaining washer securely fastened to the stud.

The seals on the sealed stud-type track rollers are located in the counterbores of the outer ring and seal against the stud flange and the retaining washer, providing good retention of lubricant and exclusion of foreign material. The seals are thermally stable in a temperature range between -30° C and 110° C (-25° F and 225° F).

A screwdriver slot (standard) or a hexagonal wrench socket (customer requested) in the head of the stud facilitates mounting. Wrench sizes are listed on the dimensional tables where found among certain GC Series sizes, beginning on page B-226. Other metric series hexagonal socket sizes are listed in Table B-29.

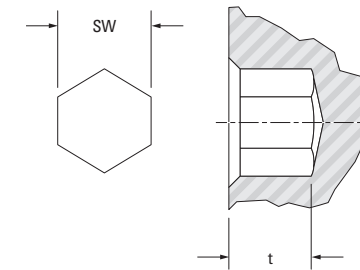

Fig. B-57. Hexagonal socket – metric series.

Table B-29. Hexagonal socket wrench sizes

Stud-type track roller O.D.		SW	t
>	≤	mm in	mm in
-	16.000 0.6299	3.000 0.1181	2.500 0.0984
19.000 0.7480	26.000 1.0236	4.000 0.1575	2.500 0.0984
30.000 1.1811	35.000 1.3779	6.000 0.2362	4.000 0.1575
40.000 1.5748	52.000 2.0472	8.000 0.3150	5.000 0.1968
62.000 2.4409	72.000 2.8346	12.000 0.4724	7.000 0.2756
80.000 3.1496	90.000 3.5433	17.000 0.6693	10.000 0.3937

ECCENTRIC STUDS FOR STUD-TYPE TRACK ROLLERS

To provide radial adjustment of the outer ring toward the track or cam surface at the time of installation, some metric series stud-type track rollers are available with eccentric studs – specified by adding the letter “E” to the designation letters: KRE and NUKRE. The GCR and GCUR Series include an eccentric bushing added to the track roller stud. Appropriate dimensions of the eccentric stud bushing are listed in Table B-30 and Table B-31 on page B-214.

Since a track roller with an eccentric stud is usually adjusted upon installation by turning the stud in the mounting hole, a close clearance fit between the outer diameter of the bushing and the mounting hole is necessary. For turning the stud, a hexagonal wrench is generally more convenient than a screwdriver. Thus, the option of a hexagonal wrench socket in the head of the stud should be exercised.

Some applications may require more secure positioning than provided by the tightened stud nut. If so, it is recommended that the mounting hole and the eccentric bushing be drilled at the time of installation to accept a locating dowel pin.

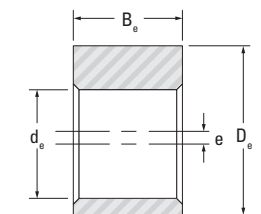

Fig. B-58. Eccentric bushing dimensions – metric series (except GCR, GCUR series)

Table B-30. Eccentric bushing dimensions – metric series (except GCR, GCUR series)

Stud-type track roller O.D.		d _o	D _o	B _e	e
>	≤	mm in	mm in	mm in	mm in
Eccentric bushing dimensions					
19.000 0.7480	19.000 0.7480	8.000 0.3150	11.000 0.4331	9.000 0.3543	0.500 0.0197
22.000 0.8661	26.000 1.10236	10.000 0.3937	13.000 0.5118	10.000 0.3937	0.500 0.0197
30.000 1.1811	32.000 1.2598	12.000 0.4724	15.000 0.5905	11.000 0.4331	0.500 0.0197
35.000 1.3779	35.000 1.3779	16.000 0.6299	20.000 0.7874	14.000 0.5512	1.000 0.0394
40.000 1.5748	40.000 1.5748	18.000 0.7087	22.000 0.8661	16.000 0.6299	1.000 0.0394
47.000 1.8504	52.000 2.0472	20.000 0.7874	24.000 0.9449	18.000 0.7087	1.000 0.0394
62.000 2.4409	72.000 2.8346	24.000 0.9449	28.000 1.1024	22.000 0.8661	1.000 0.0394
80.000 3.1496	90.000 3.5433	30.000 1.1811	35.000 1.3779	29.000 1.1417	1.500 0.0591

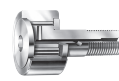

Table B-31. Eccentric bushing dimensions metric series GCR and GCUR

Table with 6 columns: Stud-type track roller O.D. (Over, Incl.), d_e, D_e, B_e, e. Rows list various dimensions in mm and inches.

METRIC SERIES YOKE-TYPE TRACK ROLLERS WITHOUT END WASHERS

These yoke-type track rollers are available with a profiled or a cylindrical outer diameter of the outer ring, and with or without a separable inner ring.

YOKE-TYPE TRACK ROLLERS – SERIES RSTO AND STO

Series STO have a separable inner ring and when the inner ring is removed they become series RSTO. They run directly on a hardened and ground inner raceway.

SEALED YOKE-TYPE TRACK ROLLERS WITHOUT END WASHERS – SERIES RNA 22.2RS AND NA22.2RS

These yoke-type track rollers have the same bore diameter and outer diameter as most of the other metric series yoke-type track rollers listed in this catalog.

thermally stable in a temperature range between -30° C and 110° C (-25° F and 225° F). Care should be exercised when mounting track rollers without inner rings onto inner raceways, to avoid damage to the seals.

METRIC SERIES YOKE-TYPE TRACK ROLLERS WITH END WASHERS

These yoke-type track rollers are available with a crowned or a cylindrical outer diameter to the outer ring. Metric series yoke-type track rollers with end washers – depending on the internal construction – may be end guided, either through the end washers or between the end faces of the rollers and the inside faces of the outer ring flanges.

YOKE-TYPE TRACK ROLLERS – SERIES NATR AND STO.ZZ

The series NATR yoke-type track rollers are of non-separable design, consisting of a crowned or a cylindrical outer ring, caged needle rollers, an inner ring and two retaining end washers securely fastened to the inner ring.

YOKE-TYPE TRACK ROLLERS – SERIES NUTR

The series NUTR yoke-type track rollers are of non-separable design consisting of a crowned or cylindrical outer ring, two rows of full complements of cylindrical rollers, an inner ring, two retaining end washers and two shields.

A lubricating hole in the inner ring enables re-lubrication when a cross-drilled bolt or shaft, which can be serviced from the end, is used.

The smallest track roller of this series has an outer diameter of 35.000 mm (1.3780 in). NUTR yoke-type track rollers are well-suited to carry high loads and designs with a thicker outer ring and particularly suitable for high shock loads.

YOKE-TYPE TRACK ROLLERS – SERIES FP AND FG

The FP and FG non-separable inner ring designs are available in crowned or cylindrical outer rings. Both employ a full complement of needle rollers and require re-lubrication via a pathway through the shaft.

YOKE-TYPE TRACK ROLLERS – SERIES FGU (LIGHT AND HEAVY TYPES)

The FGU non-separable inner ring designs are available in crowned or cylindrical outer rings. All FGU series use a full complement of cylindrical rollers between the inner and outer rings and require re-lubrication via a pathway through the shaft.

Both FGU series are only available with a metal shield for a roller sealing option.

YOKE-TYPE TRACK ROLLERS – SERIES RNA, RNAB, RNAL

The RNA and RNAB Series design uses a full complement of needle rollers retained with a pair of end washers. A separate, matching inner ring is listed in the tables of part numbers.

DIMENSIONAL ACCURACY

The tolerances of the basic metric series caged roller and NUKR stud-type and yoke-type track rollers, whose outer rings have a cylindrical outer diameter, correspond to tolerances specified in ISO 492 Radial bearings tolerances.

have h9 tolerance on profiled outer diameters and h7 for straight diameters. Stud diameter and stud length tolerances are given in Table B-33.

MOUNTING STUD-TYPE TRACK ROLLERS

When the stud shank of a metric series stud-type track roller is mounted in a hole of tolerance H7, the installation force should be applied only to the center portion of the flanged end of the stud – preferably with an arbor press.

Table B-33. Tolerances for stud diameter and stud length – metric series

Table with 6 columns: d1, Δd1s, B2, ΔB2. Rows show tolerances for stud diameter and length in mm and μm.

Table B-32. Outer ring – metric series (caged roller and NUKR, NUTR types)

Table with 9 columns: D, ΔDmp (Cylindrical, Crowned), ΔCs, Kea. Rows list dimensions and tolerances for various roller sizes.

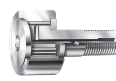

Table B-34. Inner ring – metric series (caged roller types)

Tolerances in μm (0.001 mm)

d		Δ_{dmp}		Δ_{Bs}	
>	\leq	Max.	Min.	Max.	Min.
mm in	mm in	mm in	mm in	mm in	mm in
2.500 0.0984	18.000 0.7087	0.000 0.0000	-0.008 -0.0003	0.000 0.0000	-0.180 -0.0071
18.000 0.7087	30.000 1.1811	0.000 0.0000	0.010 -0.0004	0.000 0.0000	-0.210 -0.0083
30.000 1.1811	50.000 1.9685	0.000 0.0000	-0.012 -0.0005	0.000 0.0000	-0.250 -0.0098
50.000 1.9685	80.000 3.1496	0.000 0.0000	-0.015 -0.0006	0.000 0.0000	-0.300 -0.0118
80.000 3.1496	120.000 4.7244	0.000 0.0000	-0.020 -0.0008	0.000 0.0000	-0.350 -0.0138

In mounting the stud-type track roller, the retaining washer must be firmly backed up by a flat shoulder which is square with the stud center line. The shoulder diameter must be no smaller than the minimum clamping diameter, d_a listed in the bearing tables.

The maximum inherent strength of the stud is obtained when the track roller is supported, as close as possible, to the retaining washer – which minimizes the bending moment. For this reason the edge of the housing – which supports the stud shank – should be kept as sharp as practical but free from burrs.

The clamping nut should not be tightened with a torque value higher than the maximum listed. A screwdriver slot, or hexagonal wrench socket in the flanged end of the stud, is provided for a tool to prevent the stud from turning when the nut is being tightened. Since the bottom of the screwdriver slot is not flat, it is helpful to put a radius on the tip of the screwdriver being used to hold the stud more securely. Hexagonal nuts are supplied with all metric series stud-type track rollers.

YOKE-TYPE TRACK ROLLERS

The machine element with the holes in which the mounting bolt or shaft is supported must be sufficiently rigid to resist local crushing under the applied load and to resist bending which can cause uneven loading of the needle rollers.

When applied loads are high, the h6 or j6 tolerance should be used in conjunction with a high strength shaft or bolt for mounting metric series yoke-type track rollers. When loads are moderate, a g6 tolerance may be used with a high strength shaft or bolt. For light loads, the loose transition fit with the f6 tolerance may be used with an unhardened shaft or bolt.

The yoke-type track rollers with inner rings – including those with end washers as well as inner rings – should be clamped endwise between parallel faces, perpendicular to the axis to prevent the retaining washers from coming off under load. The dimensions of machine parts, adjoining the metric series yoke-type track rollers, should be based on the minimum clamping diameter d_a to ensure that the washers are adequately supported. If the track roller cannot be end clamped, a close axial fit in the yoke is required. Care should be taken to assure that the lubricating hole is located in the unloaded zone of the raceway.

The metric series yoke-type track rollers without inner rings require a hardened and ground shaft, or bolt with a k5 tolerance. Inner raceway quality requirements are given in the engineering section.

**LOAD RATINGS
DYNAMIC LOADING AS A TRACK ROLLER**

When the outer ring of a stud-type or yoke-type track roller runs on a track, the contact – under a radial load – causes elastic (oval) deformation of the outer ring. As a result, a smaller zone of the raceway is loaded and the load is distributed on fewer needle rollers. This, in turn, affects the dynamic and static load ratings of the track rollers. Also, this deformation generates bending stress in the outer ring which must not exceed the maximum permitted for the material of the outer ring. The maximum permissible dynamic ($F_{r\text{perm}}$) radial load condition is determined by this requirement.

The rating life of stud-type or yoke-type track rollers should be calculated using the dynamic load ratings, C_w , shown in the following tables. The tables also show the maximum permissible radial load, $F_{r\text{perm}}$, that can be dynamically applied on stud-type or yoke-type track rollers. However, to calculate the L_{10} life of a track roller, the applied radial load must not be greater than $C_w/2$ based on ideal operating conditions of alignment, lubrication, temperature, speed and accelerations.

Example:

Given: A track roller application for a linear slide in which each roller supports a 453.59 kg (1000 lbs.) load and travels at 609.600 mm (24.0000 in) per second.

Select a track roller and calculate the L_{10} life in hours assuming continuous operation at the given speed. Assume conditions of alignment, lubrication and temperature are ideal.

Solution: Calculate the minimum C_w required.

The applied radial load must not be greater than $C_w/2$ based on ideal operating conditions.

Therefore, $Fr < C_w/2$ or $C_w > 907.18 \text{ kN}$ (2000 lbs.)

For a KRV30, $C_w = 1002.4 \text{ kN}$ (2210 lbs.)

To calculate the speed in min^{-1} , $V = \text{Pi} \cdot D \cdot n$

Where:

- V = linear velocity
- Pi = 3.14
- D = outside diameter of the track roller assembly

Therefore, $609.600 \text{ mm (24.000 in)/sec.} = 3.14 \cdot 30.000 \text{ mm} \cdot n$

Making appropriate substitutions and solving for n yields a value of approximately 388 min^{-1} .

The standard catalog life equation of a roller bearing is:

$L_{10} = (C/P)^{10/3} \cdot (16667/n)$

Where:

- L_{10} = calculated fatigue life in hours
- C = the dynamic radial load ratings based on 1000000 revolutions
- P = the dynamic equivalent radial load
- n = speed in min^{-1}

Substituting C_w for C and solving:

$L_{10} = (2210/1000)^{10/3} \cdot (16667/388) = 604 \text{ hours}$

STATIC RATING AS A TRACK ROLLER

In addition to the basic static load rating, C_0 , the tables also list the maximum permissible static radial load, $F_{0r\text{perm}}$, that may be applied to a stud-type or yoke-type metric series track roller. The values of $F_{0r\text{perm}}$ result in a calculated minimum static factor f_s of 0.7 for the worst condition of internal load distribution in metric series track roller operation. **The $F_{0r\text{perm}}$ values must not be exceeded.** Exceeding $F_{0r\text{perm}}$ may cause permanent damage to the track roller. A damaged track roller could cause the equipment in which the track roller is installed to malfunction. The static factor f_s can be calculated using the following formula:

$f_s \geq 0.7 \left(\frac{F_{0r\text{perm}}}{P_{0r}} \right)$

Where:

- $F_{0r\text{perm}}$ = Maximum permissible static radial load
- P_{0r} = Equivalent static load (F_{0r} for yoke-type track rollers)
- F_{0r} = Static radial load
- f_s = Static factor whose values should not be smaller than those suggested in Table B-35.

Table B-35. Suggested values for static factors f_s for metric series track rollers

Requirements for yoke – type track rollers and stud – type track rollers	Suggested f_s values	
	Max.	Min.
High shock-type loads Quiet running	2.5	1.5
Normal loading Normal quietness of running	1.5	1
Minor impact loads and rotary motion particularly quiet running not required	1	0.7

LUBRICATION OF STUD-TYPE TRACK ROLLERS

JTEKT metric series stud-type track rollers are supplied with a lithium soap-based, general-purpose grease. When the caged KR Series track rollers are operated at low speeds, with light loads and in clean environments, there is often no need to re-lubricate the track roller. In other applications, periodic re-lubrication may be necessary to obtain optimum performance. The full complement series of track rollers have less internal volume available for grease storage. Therefore, they may require more frequent lubrication than caged-type track rollers. Stud-type track rollers – with a screwdriver slot in the flanged end of the stud – have provisions for re-lubrication through the flanged end of the stud. Metric series stud-type track rollers, with hexagonal sockets, can not be re-lubricated from the flanged end of the stud. Both types of metric series stud-type track rollers – with outer diameters larger than 22.000 mm (0.8661 in) (28.000 mm [1.1024 in] for all GC variations) – allow for re-lubrication through the threaded end of the stud. In addition, caged roller and NUKR Series stud-type track rollers – with 30.000 mm (1.8110 in) and larger outer diameters – allow for re-lubrication through a cross-drilled hole in the stud shank. The ends of the axial holes are counterbored to accept press-fit grease fittings of series VENN. The grease fittings are supplied with metric series stud-type track rollers. Hole diameters (d_4) for these grease fittings are listed in the tables of dimensions on pages later in this chapter as it applies. Note that the GC small series has no axial hole.

One or more plugs are supplied with every metric series stud-type track roller, to close off unused holes. At the flanged end, the plug must not be pushed in too deeply, as it may cover the cross-drilled lubricating hole. The plug should be pressed in using an installation tool whose dimensions are given in Table B-37. If the cross-drilled hole in the stud shank is not used, it will be covered when the track roller is properly installed.

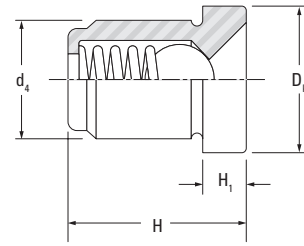

Fig. B-59. Metric series grease fittings

Table B-36. Metric series grease fittings, series VENN

Designation	d_4	D_K	H	H_1	Approx. wt.
	mm in	mm in	mm in	mm in	g lbs
VENN 4	4.000 0.1575	6.000 0.2362	6.000 0.2362	1.500 0.0591	0.4 0.0009
VENN 6	6.000 0.2362	8.000 0.3147	7.000 0.2756	2.000 0.0787	1.6 0.0035
VENN 8	8.000 0.3150	10.000 0.3937	12.000 0.4724	3.000 0.1181	4.7 0.0104

During installation of the track roller it is desirable to ensure that the cross-drilled hole is positioned in the unloaded zone of the track roller raceway. The location of the cross-drilled hole can be best recognized by its alignment with the manufacturer's stamp, parallel to the screwdriver slot (when applicable).

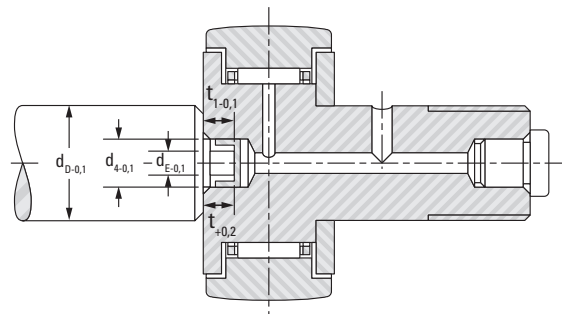

Fig. B-60. Installation tool for metric series plug

Table B-37. Installation tool for metric series plug

Stud-type track roller O.D.		d_4	d_D	d_E	t	t_1
>	≤	mm in	mm in	mm in	mm in	mm in
16.000 0.6299	26.000 1.0236	3.900 0.1535	10.000 0.3937	2.700 0.1063	3.700 0.1457	4.500 0.1772
30.000 1.1811	40.000 1.5748	5.900 0.2323	12.000 0.4724	4.700 0.1850	4.700 0.1850	7.000 0.2756
47.000 1.8504	90.000 3.5433	7.900 0.3110	15.000 0.5905	6.700 0.2638	6.700 0.2638	10.000 0.3937

LUBRICATION OF YOKE-TYPE TRACK ROLLERS

Yoke-type track rollers are produced with a lubricating hole in the inner ring so they can be re-lubricated through a cross-drilled hole in the supporting shaft or bolt. When mounting yoke-type track rollers, care should be taken that the lubrication hole is located in the unloaded raceway zone.

Oil is the preferred lubricant for yoke-type track rollers. Continuous oil lubrication, or frequent grease lubrication should be used for steady rotating conditions. Applications involving slow, intermittent oscillations are not as critical, and longer intervals between re-lubrication are permitted. Sealed yoke-type track rollers are normally supplied with an initial charge of a medium-temperature grease. Caged yoke-type track rollers have maximum grease storage capacity and, consequently, longer pregreased life than full complement types.

**NEEDLE ROLLER AND CAGE ASSEMBLIES,
STUD-TYPE (KR SERIES)
METRIC SERIES**

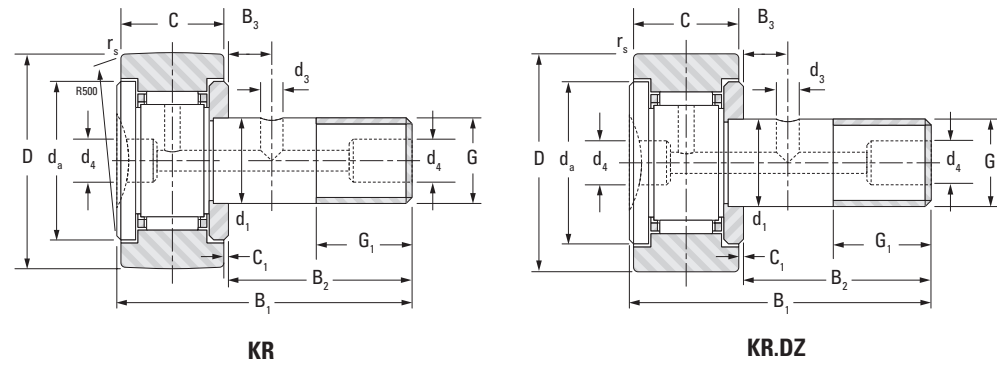

KR

KR.DZ

Outer Dia.	d ₁	D, h7	C	r _{s min}	B ₁	B ₂	B ₃	G ₁	d ₄	d ₃	G		d _a
											Thread	C ₁	
16 0.6299	6 0.2362	16 0.6299	11 0.433	0.3 0.012	28.2 1.110	16 0.630		8 0.315	4 0.157		M6x1	0.6 0.024	11 0.433
19 0.7480	8 0.3150	19 0.7480	11 0.433	0.3 0.012	32.2 1.268	20 0.787		10 0.394	4 0.157		M8x1.25	0.6 0.024	13 0.512
22 0.8661	10 0.3937	22 0.8661	12 0.472	0.3 0.012	36.0 1.417	23 0.906		12 0.472	4 0.157		M10x1	0.6 0.024	15 0.591
26 1.0236	10 0.3937	26 1.0236	12 0.472	0.3 0.012	36.0 1.417	23 0.906		12 0.472	4 0.157		M10x1	0.6 0.024	15 0.591
30 0.551	12 0.4724	30 1.1811	14 0.551	0.6 0.024	40.0 1.575	25 0.984	6 0.236	13 0.512	6 0.236	3 0.118	M12x1.5	0.6 0.024	21 0.827
32 0.551	12 0.4724	32 1.2598	14 0.551	0.6 0.024	40.0 1.575	25 0.984	6 0.236	13 0.512	6 0.236	3 0.118	M12x1.5	0.6 0.024	21 0.827

Crowned Designation	Cylindrical Designation	Load Ratings					Tightening Torque	Speed Rating Grease	Wt.
		As a Bearing		As a Track Roller					
		Dynamic	Static	Dynamic	Static				
C	C ₀	C _w	F _{r perm}	F _{0r perm}		N-m lb-in	min ⁻¹	kg lbs	
KR16	KR16.DZ	3.60 810	3.58 800	2.97 670	2.85 640	3.58 800	7 62.0	17000	0.019 0.042
KR19	KR19.DZ	4.18 940	4.65 1050	3.28 740	3.29 740	4.22 950	16 142	13000	0.031 0.068
KR22	KR22.DZ	5.35 1200	6.79 1530	3.94 890	4.04 910	5.45 1230	28 248	10000	0.046 0.101
KR26	KR26.DZ	5.35 1200	6.79 1530	4.55 1020	6.78 1520	7.24 1630	28 248	10000	0.059 0.130
KR30	KR30.DZ	7.89 1770	9.79 2200	6.32 1420	7.74 1740	9.31 2090	45 398	8200	0.087 0.192
KR32	KR32.DZ	7.89 1770	9.79 2200	6.65 1490	9.62 2160	10.3 2320	45 398	8200	0.095 0.209

**NEEDLE ROLLER AND CAGE ASSEMBLIES, SEALED,
STUD-TYPE (KR...2S SERIES)
METRIC SERIES**

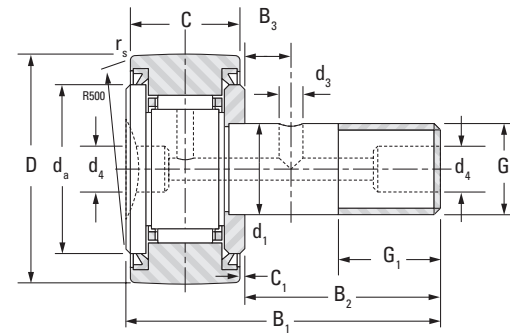

KR.2RS

Outer Dia.	d ₁	D, h7	C	r _{s min}	B ₁	B ₂	B ₃	G ₁	d ₄	d ₃	G		C ₁	d _a
											Thread			
mm in	mm in	mm in	mm in	mm in	mm in	mm in	mm in	mm in	mm in	mm in		mm in	mm in	
16 0.6299	6 0.2362	16 0.6299	11 0.433	0.3 0.012	28.2 1.110	16 0.630		8 0.315	4 0.157		M6x1	0.6 0.024	11 0.433	
19 0.7480	8 0.3150	19 0.7480	11 0.433	0.3 0.012	32.2 1.268	20 0.787		10 0.394	4 0.157		M8x1.25	0.6 0.024	13 0.512	
22 0.8661	10 0.3937	22 0.8661	12 0.472	0.3 0.012	36.2 1.425	23 0.906		12 0.472	4 0.157		M10x1	0.6 0.024	15 0.591	
26 1.0236	10 0.3937	26 1.0236	12 0.472	0.3 0.012	36.2 1.425	23 0.906		12 0.472	4 0.157		M10x1	0.6 0.024	15 0.591	
30 1.1811	12 0.4724	30 1.1811	14 0.551	0.6 0.024	40.2 1.583	25 0.984	6 0.236	13 0.512	6 0.236	3 0.118	M12x1.5	0.6 0.024	21 0.827	
32 1.2598	12 0.4724	32 1.2598	14 0.551	0.6 0.024	40.2 1.583	25 0.984	6 0.236	13 0.512	6 0.236	3 0.118	M12x1.5	0.6 0.024	21 0.827	

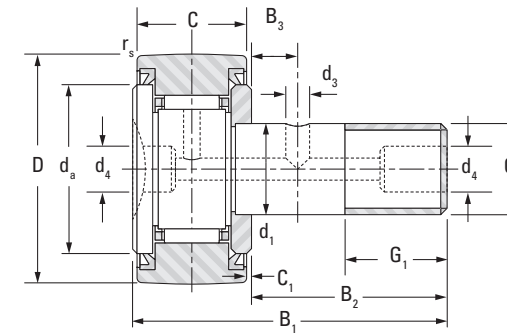

KR.DZ.2RS

Crowned Designation	Cylindrical Designation	Load Ratings					Tightening Torque	Speed Rating Grease	Wt.
		As a Bearing		As a Track Roller					
		Dynamic	Static	Dynamic		Static			
		C	C ₀	C _w	F _{r perm}	F _{0r perm}			
		kN lbf		kN lbf		N-m lb-in	min ⁻¹	kg lbs	
KR16.2RS	KR16.DZ.2RS	3.60 810	3.58 800	2.97 670	2.85 640	3.58 800	7.0 61.96	17000	0.019 0.042
KR19.2RS	KR19.DZ.2RS	4.18 940	4.65 1050	3.28 740	3.29 740	4.22 950	16 141.61	13000	0.031 0.068
KR22.2RS	KR22.DZ.2RS	5.35 1200	6.79 1530	3.94 890	4.04 910	5.45 1230	28 247.82	10000	0.046 0.101
KR26.2RS	KR26.DZ.2RS	5.35 1200	6.79 1530	4.55 1020	6.78 1520	7.24 1630	28 247.82	10000	0.059 0.130
KR30.2RS	KR30.DZ.2RS	7.89 1770	9.79 2200	6.32 1420	7.74 1740	9.31 2090	45 398.28	8200	0.087 0.192
KR32.2RS	KR32.DZ.2RS	7.89 1770	9.79 2200	6.65 1490	9.62 2160	10.3 2320	45 398.28	8200	0.098 0.216

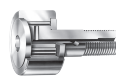

**FULL COMPLEMENT WITH
NEEDLE ROLLERS
(KRV SERIES)
OR CYLINDRICAL
ROLLERS, STUD-TYPE
(NUKR SERIES)**

METRIC SERIES

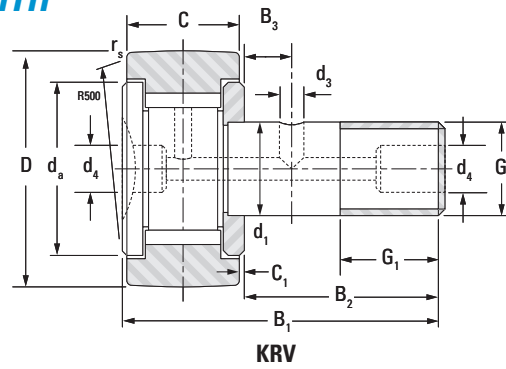

KRV

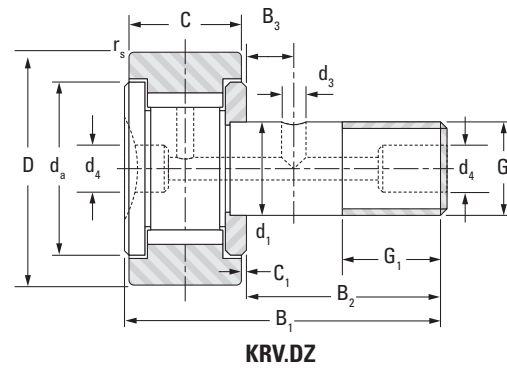

KRV.DZ

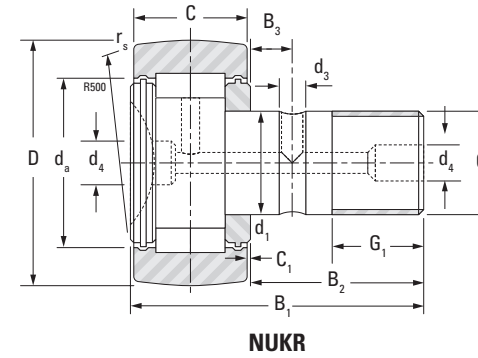

NUKR

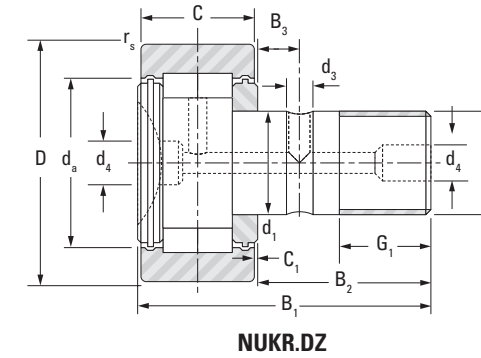

NUKR.DZ

Outer Dia.	d ₁	D, h7	C	r _{s min}	B ₁	B ₂	B ₃	G ₁	d ₄	d ₃	G		d _a
											Thread	C ₁	
mm in	mm in	mm in	mm in	mm in	mm in	mm in	mm in	mm in	mm in	mm in		mm in	mm in
16 0.6299	6 0.2362	16 0.6299	11 0.433	0.3 0.012	28.2 1.110	16 0.630		8 0.315	4 0.157		M6x1	0.6 0.024	11 0.433
19 0.7480	8 0.3150	19 0.7480	11 0.433	0.3 0.012	32.2 1.268	20 0.787		10 0.394	4 0.157		M8x1.25	0.6 0.024	13 0.512
22 0.8661	10 0.3937	22 0.8661	12 0.472	0.3 0.012	36.2 1.425	23 0.906		12 0.472	4 0.157		M10x1	0.6 0.024	15 0.591
26 1.0236	10 0.3937	26 1.0236	12 0.472	0.3 0.012	36.2 1.425	23 0.906		12 0.472	4 0.157		M10x1	0.6 0.024	15 0.591
30 1.1811	12 0.4724	30 1.1811	14 0.551	0.6 0.024	40.2 1.583	25 0.984	6 0.236	13 0.512	6 0.236	3 0.118	M12x1.5	0.6 0.024	21 0.827
32 1.2598	12 0.4724	32 1.2598	14 0.551	0.6 0.024	40.2 1.583	25 0.984	6 0.236	13 0.512	6 0.236	3 0.118	M12x1.5	0.6 0.024	21 0.827
35 1.3780	16 0.6299	35 1.3780	18 0.709	0.6 0.024	52 2.047	32.5 1.280	8 0.315	17 0.669	6 0.236	3 0.118	M16x1.5	0.8 0.031	25 0.984
40 1.5748	18 0.7087	40 1.5748	20 0.787	1 0.039	58 2.283	36.5 1.437	8 0.315	19 0.748	6 0.236	3 0.118	M18x1.5	0.8 0.031	27 1.063
47 1.8504	20 0.7874	47 1.8504	24 0.945	1 0.039	66 2.598	40.5 1.594	9 0.354	21 0.827	6 0.236	4 0.157	M20x1.5	0.8 0.031	33 1.299
52 2.0472	20 0.7874	52 2.0472	24 0.945	1 0.039	66 2.598	40.5 1.594	9 0.354	21 0.827	6 0.236	4 0.157	M20x1.5	0.8 0.031	37 1.457
62 2.4409	24 0.9449	62 2.4409	29 1.142	1 0.039	80 3.150	49.5 1.949	11 0.433	25 0.984	8 0.315	4 0.157	M24x1.5	0.8 0.031	45 1.772
72 2.8346	24 0.9449	72 2.8346	29 1.142	1.1 0.043	80 3.150	49.5 1.949	11 0.433	25 0.984	8 0.315	4 0.157	M24x1.5	0.8 0.031	51 2.008
80 3.1496	30 1.1811	80 3.1496	35 1.378	1.1 0.043	100 3.937	63 2.480	15 0.591	32 1.260	8 0.315	4 0.157	M30x1.5	1.0 0.039	52 2.047
90 3.5433	30 1.1811	90 3.5433	35 1.378	1.1 0.043	100 3.937	63 2.480	15 0.591	32 1.260	8 0.315	4 0.157	M30x1.5	1.0 0.039	52 2.047

Crowned Designation	Cylindrical Designation	Load Ratings					Tightening Torque	Speed Rating Grease	Wt.
		As a Bearing		As a Track Roller					
		Dynamic	Static	Dynamic		Static			
		C	C ₀	C _w	F _{r perm}	F _{0r perm}			
		kN lbf		kN lbf		N-m lb-in	min ⁻¹	kg lbs	
KRV16	KRV16.DZ	6.90 1550	8.40 1890	5.11 1150	3.49 780	6.28 1410	7 62.0	5700	0.019 0.042
KRV19	KRV19.DZ	8.08 1820	11.0 2470	5.66 1270	4.13 930	7.43 1670	16 142	4300	0.031 0.068
KRV22	KRV22.DZ	9.45 2120	14.3 3210	6.32 1420	5.04 1130	9.07 2040	28 248	3400	0.046 0.101
KRV26	KRV26.DZ	9.45 2120	14.3 3210	7.30 1640	8.60 1930	12.7 2860	28 248	3400	0.059 0.130
KRV30	KRV30.DZ	13.4 3010	19.8 4450	9.85 2210	9.20 2070	15.7 3530	45 398	2800	0.087 0.192
KRV32	KRV32.DZ	13.4 3010	19.8 4450	10.4 2340	11.3 2540	17.4 3910	45 398	2800	0.098 0.216
NUKR35.2SK		24.7 5550	29.4 6610	16.2 3640	10.1 2270	16.1 3620	53.2 471	6100	0.170 0.375
NUKR40.2SK		26.6 5980	33.3 7490	18.7 4200	15.0 3370	23.9 5370	77.5 686	5300	0.250 0.551
NUKR47.2SK		41.4 9310	53.2 12000	28.1 6320	20.5 4610	32.7 7350	109 965	4500	0.380 0.838
NUKR52.2SK		45.8 10300	63.1 14200	29.6 6650	22.2 4990	35.4 7960	109 965	3700	0.461 1.016
NUKR62.2SK		62.7 14100	83.1 18700	40.9 9190	29.6 6650	47.2 10600	193 1708	3200	0.790 1.742
NUKR72.2SK		68.9 15500	97.8 22000	46.1 10400	39.6 8900	63.1 14200	193 1708	2600	1.040 2.293
NUKR80.2SK		95.4 21400	130 29200	69.7 15700	63.2 14200	101 22700	390 3452	2900	1.550 3.417
NUKR90.2SK		95.4 21400	130 29200	77.8 17500	97.8 22000	128 28800	390 3452	2900	2.020 4.453



**FULL COMPLEMENT, SMALL SERIES,
UNSEALED,
STUD-TYPE (GC SERIES)
METRIC SERIES**

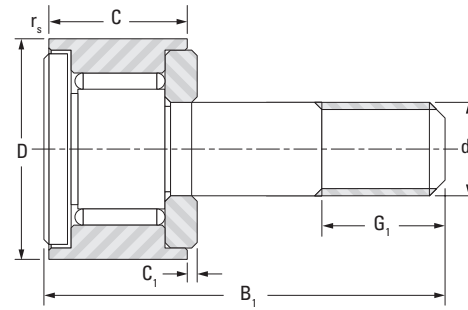

GC10-15/GCL10-15 Series

Outer Dia.	D	d ₁	Thread	C	C ₁	r _s min	B ₁	G ₁
mm in	mm in	mm in		mm in	mm in	mm in	mm in	mm in
10 0.3937	10 0.3937	4 0.1575	M4 x 0.7	8 0.315	0.25 0.010	0.2 0.008	19.5 0.768	6 0.236
11 0.4331	11 0.4331	4 0.1575	M4 x 0.7	8 0.315	0.25 0.010	0.2 0.008	19.5 0.768	6 0.236
12 0.4724	12 0.4724	5 0.1969	M5 x 0.8	9 0.354	0.25 0.010	0.2 0.008	22.5 0.886	7 0.276
13 0.5118	13 0.5118	5 0.1969	M5 x 0.8	9 0.354	0.25 0.010	0.2 0.008	22.5 0.886	7 0.276
14 0.5512	14 0.5512	6 0.2362	M6 x 1	9.5 0.374	0.25 0.010	0.3 0.012	26 1.024	8 0.315
15 0.5906	15 0.5906	6 0.2362	M6 x 1	9.5 0.374	0.25 0.010	0.3 0.012	26 1.024	8 0.315

Crowned Designation	Cylindrical Designation	Tightening Torque	Load Ratings					Speed Rating Grease	Wt.
			As a Bearing		As a Track Roller				
			C	C ₀	C _w	F _{r perm}	F _{0r perm}		
		N-m lb-in	kN lbf		kN lbf			min ⁻¹	kg lbs
GC 10	GCL 10	0.9 7.97	2.80 629	3.09 695	1.92 432	1.01 227	1.82 409	8500	0.006 0.014
GC 11	GCL 11	0.9 7.97	2.8 629	3.09 695	2.12 477	1.43 321	2.58 580	8500	0.007 0.016
GC 12	GCL 12	1.8 15.93	3.74 841	4.74 1070	2.54 571	1.63 366	2.94 661	6600	0.011 0.024
GC 13	GCL 13	1.8 15.93	3.74 841	4.74 1070	2.16 486	2.75 618	3.89 874	6600	0.011 0.024
GC 14	GCL 14	3.0 26.55	4.05 910	5.44 1220	2.86 643	2.26 508	4.07 915	5700	0.016 0.035
GC 15	GCL 15	3.0 26.55	4.05 910	5.44 1220	3.04 683	2.83 636	4.65 1050	5700	0.018 0.039

**FULL COMPLEMENT,
STANDARD SERIES,
WITH OR WITHOUT SEALS,
STUD-TYPE (GC SERIES)
METRIC SERIES**

GC: crowned outer ring
GCL: cylindrical outer ring
EE: with plastic seals
EEM: with metal seals

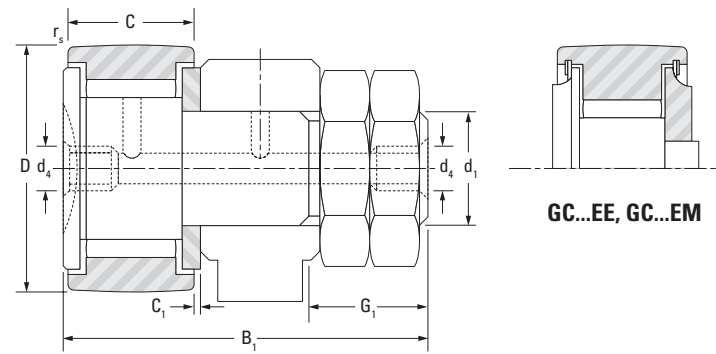

GC16-90/GCL16-90 Series

Outer Dia.	D	d ₁	Pitch	C	C ₁	r _{s min}	B ₁	G ₁	Crowned Designation	Cylindrical Designation
mm in	mm in	mm in	mm	mm in	mm in	mm in	mm in	mm in		
16 0.6299	16 0.6299	6 0.2362	1.0	11 0.433	0.60 0.024	0.3 0.012	28.3 1.114	8 0.315	GC 16	GCL 16
19 0.748	19 0.748	8 0.315	1.25	11 0.433	0.60 0.024	0.3 0.012	32.3 1.272	10 0.394	GC 19	GCL 19
22 0.8661	22 0.8661	10 0.3937	1.25	12 0.472	0.60 0.024	0.3 0.012	36.3 1.429	12 0.472	GC 22	GCL 22
24 0.9449	24 0.9449	10 0.3937	1.25	12 0.472	0.60 0.024	0.3 0.012	36.3 1.429	12 0.472	GC 24	GCL 24
26 1.0236	26 1.0236	10 0.3937	1.25	12 0.472	0.60 0.024	0.3 0.012	36.3 1.429	12 0.472	GC 26	GCL 26
28 1.1024	28 1.1024	10 0.3937	1.25	12 0.472	0.60 0.024	0.3 0.012	36.3 1.429	12 0.472	GC 28	GCL 28
30 1.1811	30 1.1811	12 0.4724	1.5	14 0.51	0.60 0.024	0.6 0.024	40.3 1.587	13 0.512	GC 30	GCL 30
32 1.2598	32 1.2598	12 0.4724	1.5	14 0.51	0.60 0.024	0.6 0.024	40.3 1.587	13 0.512	GC 32	GCL 32
35 1.378	35 1.378	16 0.6299	1.5	18 0.709	0.80 0.031	0.6 0.024	52.3 2.059	17 0.669	GC 35	GCL 35
47 1.8504	47 1.8504	20 0.7874	1.5	24 0.45	0.80 0.031	1 0.039	66.3 2.61	21 0.827	GC 47	GCL 47
52 2.0472	52 2.0472	20 0.7874	1.5	24 0.45	0.80 0.031	1 0.039	66.3 2.61	21 0.827	GC 52	GCL 52
62 2.4409	62 2.4409	24 0.9449	1.5	29 1.142	0.80 0.031	1 0.039	80.3 3.161	25 0.984	GC 62	GCL 62
72 2.8346	72 2.8346	24 0.9449	1.5	29 1.142	0.80 0.031	1 0.039	80.3 3.161	25 0.984	GC 72	GCL 72
80 3.1496	80 3.1496	30 1.1811	1.5	35 1.378	1.00 0.039	1 0.039	100.3 3.949	32 1.26	GC 80	GCL 80
85 3.3465	85 3.3465	30 1.1811	1.5	35 1.378	1.00 0.039	1 0.039	100.3 3.949	32 1.26	GC 85	GCL 85
90 3.5433	90 3.5433	30 1.1811	1.5	35 1.378	1.00 0.039	1 0.039	100.3 3.949	32 1.26	GC 90	GCL 90

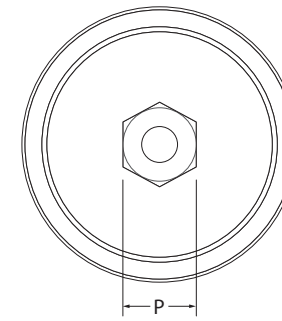

Hex Socket Roller End

Tightening Torque	Load Ratings					Speed Rating Grease	P Wrench	d ₄	Wt.
	As a Bearing		As a Track Roller						
	C	C ₀	C _w	F _{r perm}	F _{0r perm}				
N-m lb-in	kN lbf		kN lbf			min ⁻¹	mm	mm in	kg lbs
3 26.6	5.66 1270	6.51 1460	4.19 942	2.79 627	5.02 1130	5700	N/A	4 0.157	0.021 0.046
8 70.8	6.44 1450	8.15 1830	4.65 1050	3 785	6.28 1410	4400	N/A	4 0.157	0.034 0.075
20 177	7.3 1640	10.2 2290	5.05 1140	4.07 915	7.33 1650	3500	N/A	4 0.157	0.058 0.128
20 177	7.3 1640	10.2 2290	5.45 1230	5.42 1220	8.63 1940	3500	N/A	4 0.157	0.067 0.148
20 177	9.92 2230	12.9 2900	7.09 1590	5.43 1220	9.77 2200	3200	N/A	4 0.157	0.072 0.159
20 177	9.92 2230	12.9 2900	7.57 1700	6.95 1560	11.4 2560	3200	N/A	4 0.157	0.08 0.176
26 230	15.5 3480	20.4 4590	11.2 2520	8.48 1910	15.3 3440	2900	8	4 0.157	0.115 0.254
26 230	15.5 3480	20.4 4590	11.8 2650	10.6 2380	18.1 4070	2900	8	4 0.157	0.12 0.265
64 566	23.6 5310	33.1 7440	15.7 3530	10.8 2430	19.4 4360	2200	10	6 0.236	0.208 0.459
120 1060	36.5 8210	65.5 14700	22.5 5060	20.2 4540	36.4 8180	1400	14	6 0.236	0.477 1.052
120 1060	36.5 8210	65.5 14700	25.2 5670	28 6290	47.5 10700	1400	14	6 0.236	0.542 1.195
220 1950	43.3 9730	85.6 19200	30.5 6860	42.9 9640	64.7 14500	1200	12	6 0.236	0.944 2.081
220 1950	43.3 9730	85.6 19200	33.9 7620	65.8 14800	79.5 17900	1200	12	6 0.236	1.165 2.568
450 3980	65.1 14600	144 32400	42.7 9600	62.9 14100	95.3 21400	870	14	8 0.315	1.915 4.222
450 3980	65.1 14600	144 32400	45.1 10100	75.3 16900	106 23800	870	14	8 0.315	2.096 4.621
450 3980	65.1 14600	144 32400	47.1 10600	88.8 20000	115 25900	870	14	8 0.315	2.287 5.042

**FULL COMPLEMENT,
WITH METAL SEALS,
STUD-TYPE (GCU...MM SERIES)
METRIC SERIES**

GCU: crowned outer ring
GCUL: cylindrical outer ring

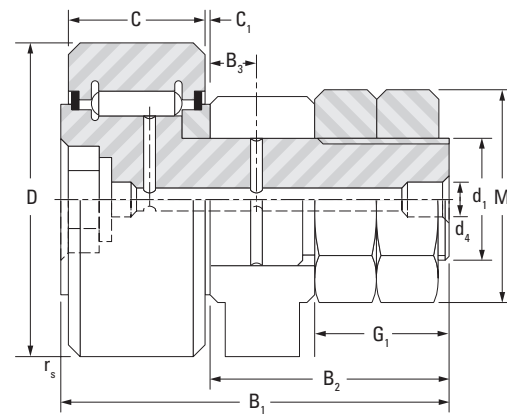

GCU, GCUL

Outer Dia.	D	d ₁	C	C ₁	B ₁	G ₁	r _s min	Crowned Designation	Cylindrical Designation
mm in	mm in	mm in	mm in	mm in	mm in	mm in	mm in		
35 1.3780	35 1.3780	16 0.6299	18 0.709	0.85 0.033	52.3 2.059	17 0.669	0.6 0.024	GCU 35 MM	GCUL 35 MM
40 1.5748	40 1.5748	18 0.7087	20 0.787	0.85 0.033	58.3 2.295	19 0.748	1.0 0.039	GCU 40 MM	GCUL 40 MM
47 1.8504	47 1.8504	20 0.7874	24 0.945	0.85 0.033	66.3 2.610	21 0.827	1.0 0.039	GCU 47 MM	GCUL 47 MM
52 2.0472	52 2.0472	20 0.7874	24 0.945	0.85 0.033	66.3 2.610	21 0.827	1.0 0.039	GCU 52 MM	GCUL 52 MM
62 2.4409	62 2.4409	24 0.9449	29 1.142	0.85 0.033	80.3 3.161	25 0.984	1.0 0.039	GCU 62 MM	GCUL 62 MM
72 2.8346	72 2.8346	24 0.9449	29 1.142	0.85 0.033	80.3 3.161	25 0.984	1.1 0.043	GCU 72 MM	GCUL 72 MM
80 3.1496	80 3.1496	30 1.1811	35 1.378	1.10 0.043	100.3 3.949	32 1.260	1.1 0.043	GCU 80 MM	GCUL 80 MM
90 3.5433	90 3.5433	30 1.1811	35 1.378	1.10 0.043	100.3 3.949	32 1.260	1.1 0.043	GCU 90 MM	GCUL 90 MM
100 3.9370	100 3.9370	36 1.4173	40 1.575	1.10 0.043	117.3 4.618	38 1.496	2.0 0.079	GCU 100 MM	GCUL 100 MM
110 4.3307	110 4.3307	36 1.4173	40 1.575	1.10 0.043	117.3 4.618	38 1.496	2.0 0.079	GCU 110 MM	GCUL 110 MM
120 4.7244	120 4.7244	42 1.6535	46 1.811	1.10 0.043	136.3 5.366	44 1.732	2.0 0.079	GCU 120 MM	GCUL 120 MM
130 5.1181	130 5.1181	42 1.6535	46 1.811	1.10 0.043	136.3 5.366	44 1.732	2.0 0.079	GCU 130 MM	GCUL 130 MM

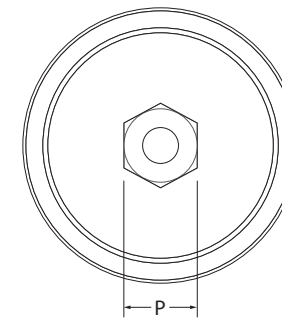

Hex Socket Roller End

Tightening Torque	Load Ratings					Speed Rating Grease	P Wrench	B ₂	B ₃	d ₄	M	Wt.
	As a Bearing		As a Track Roller									
	C	C ₀	C _w	F _{r perm}	F _{0r perm}							
64 566	26.4 5930	32.4 7280	15.4 3460	7.25 1630	13.1 2940	2200	10	32.8 1.291	8 0.315	6 0.236	26.0 1.024	0.200 0.441
90 797	26.4 5930	32.4 7280	18.7 4200	12.1 2720	21.8 4900	2200	12	36.8 1.449	8 0.315	6 0.236	28.6 1.126	0.289 0.637
120 1060	43.8 9850	57.9 13000	26.7 6000	14.3 3210	25.8 5800	1600	14	40.8 1.606	9 0.354	6 0.236	33.6 1.323	0.450 0.992
120 1060	43.8 9850	57.9 13000	30.6 6880	21.2 4770	38.2 8590	1600	14	40.8 1.606	9 0.354	6 0.236	33.6 1.323	0.520 1.146
220 1950	63.7 14300	87.4 19600	44.1 9910	30.9 6950	55.6 12500	1400	12	49.8 1.961	11 0.433	6 0.236	38.9 1.531	0.910 2.006
220 1950	63.7 14300	87.4 19600	50.8 11400	52.7 11800	84.1 18900	1400	12	49.8 1.961	11 0.433	6 0.236	38.9 1.531	1.140 2.513
450 3980	100 22500	140 31500	66.8 15000	43.8 9850	78.8 17700	1000	14	63.3 2.492	15 0.591	8 0.315	51.8 2.039	1.870 4.123
450 3980	100 22500	140 31500	75.8 17000	68.1 15300	122 27400	1000	14	63.3 2.492	15 0.591	8 0.315	51.8 2.039	2.230 4.914
740 6550	115 25900	175 39300	82.1 18500	76.6 17200	135 30300	840	17	75.3 2.965	20 0.787	8 0.315	61.0 2.402	3.290 7.253
740 6550	115 25900	175 39300	89.7 20200	107 24100	161 36200	840	17	75.3 2.965	20 0.787	8 0.315	61.0 2.402	3.800 8.378
1 200 10620	167 37500	240 54000	124 27900	107 24100	193 43400	740	19	88.3 3.476	24 0.945	8 0.315	71.0 2.795	5.422 11.953
1 200 10620	167 37500	240 54000	133 30000	142 31900	228 51300	740	19	88.3 3.476	24 0.945	8 0.315	71.0 2.795	5.780 12.743

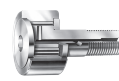

NEEDLE ROLLER BEARINGS

FULL COMPLEMENT, ECCENTRIC, STUD-TYPE (GCR SERIES) METRIC SERIES

GCR: crowned outer ring
GCRL: cylindrical outer ring

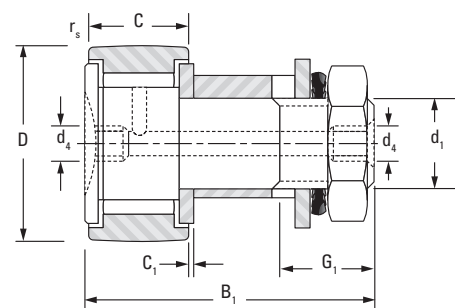

GCR 16-52

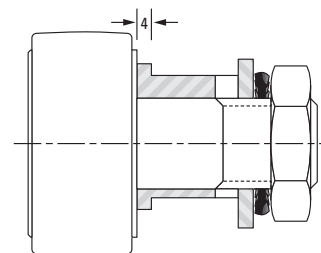

GCR 62-90

Outer Dia.	D	d ₁	C	C ₁	B ₁	G ₁	r _s min	Crowned Designation	Cylindrical Designation
mm in	mm in	mm in	mm in	mm in	mm in	mm in	mm in		
16 0.6299	16 0.6299	6 0.2362	11 0.433	0.60 0.024	28.3 1.114	8 0.315	0.3 0.012	GCR 16	
19 0.748	19 0.748	8 0.315	11 0.433	0.60 0.024	32.3 1.272	10 0.394	0.3 0.012	GCR 19	
22 0.8661	22 0.8661	10 0.3937	12 0.472	0.60 0.024	36.3 1.429	12 0.472	0.3 0.012	GCR 22	GCRL 22
24 0.9449	24 0.9449	10 0.3937	12 0.472	0.60 0.024	36.3 1.429	12 0.472	0.3 0.012	GCR 24	
26 1.0236	26 1.0236	10 0.3937	12 0.472	0.60 0.024	36.3 1.429	12 0.472	0.3 0.012	GCR 26	GCRL 26
28 1.1024	28 1.1024	10 0.3937	12 0.472	0.60 0.024	36.3 1.429	12 0.472	0.3 0.012	GCR 28	GCRL 28
30 1.1811	30 1.1811	12 0.4724	14 0.551	0.60 0.024	40.3 1.587	13 0.512	0.6 0.024	GCR 30	GCRL 30
32 1.2598	32 1.2598	12 0.4724	14 0.551	0.60 0.024	40.3 1.587	13 0.512	0.6 0.024	GCR 32	GCRL 32
35 1.378	35 1.378	16 0.6299	18 0.709	0.80 0.031	52.3 2.059	17 0.669	0.6 0.024	GCR 35	GCRL 35
40 1.5748	40 1.5748	18 0.7087	20 0.787	0.80 0.031	58.3 2.295	19 0.748	1 0.039	GCR 40	GCRL 40
47 1.8504	47 1.8504	20 0.7874	24 0.945	0.80 0.031	66.3 2.61	21 0.827	1 0.039	GCR 47 EE	GCRL 47
52 2.0472	52 2.0472	20 0.7874	24 0.945	0.80 0.031	66.3 2.61	21 0.827	1 0.039	GCR 52	GCRL 52
62 2.4409	62 2.4409	24 0.9449	29 1.142	0.80 0.031	80.3 3.161	25 0.984	1 0.039	GCR 62	GCRL 62
72 2.8346	72 2.8346	24 0.9449	29 1.142	0.80 0.031	80.3 3.161	25 0.984	1 0.039	GCR 72	GCRL 72
80 3.1496	80 3.1496	30 1.1811	35 1.378	1.00 0.039	100.3 3.949	32 1.26	1 0.039	GCR 80	
90 3.5433	90 3.5433	30 1.1811	35 1.378	1.00 0.039	100.3 3.949	32 1.26	1 0.039	GCR 90	GCRL 90

Stud-Type and Yoke-Type Track Rollers

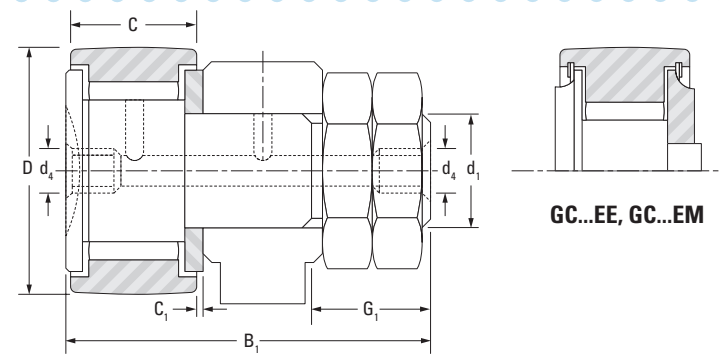

GCR..EE, GCR..EEM
GCRL..EE, GCRL..EEM

GC...EE, GC...EM

Tightening Torque	Load Ratings					Speed Rating Grease	d ₄	Wt.
	As a Bearing		As a Track Roller					
	C	C ₀	C _w	F _{r perm}	F _{0r perm}			
N-m lb-in	kN lbf		kN lbf			min ⁻¹	mm in	kg lbs
2 17.7	5.66 1270	6.51 1460	4.19 942	2.79 627	5.02 1130	5700	4 0.157	0.024 0.053
5 44.3	6.44 1450	8.15 1830	4.65 1050	3 785	6.28 1410	4400	4 0.157	0.039 0.086
16 142	7.3 1640	10.2 2290	5.05 1140	4.07 915	7.33 1650	3500	4 0.157	0.057 0.126
16 142	7.3 1640	10.2 2290	5.45 1230	5.42 1220	8.63 1940	3500	4 0.157	0.072 0.159
16 142	9.92 2230	12.9 2900	7.09 1590	5.43 1220	9.77 2200	3200	4 0.157	0.080 0.176
16 142	9.92 2230	12.9 2900	7.57 1700	6.95 1560	11.4 2560	3200	4 0.157	0.088 0.194
22 195	15.5 3480	20.4 4590	11.2 2520	8.48 1910	15.3 3440	2900	4 0.157	0.118 0.260
22 195	15.5 3480	20.4 4590	11.8 2650	10.6 2380	18.1 4070	2900	4 0.157	0.126 0.278
55 487	23.6 5310	33.1 7440	15.7 3530	10.8 2430	19.4 4360	2200	6 0.236	0.220 0.485
75 664	29.9 6720	48 10800	18.5 4160	13.8 3100	24.8 5580	1800	6 0.236	0.321 0.708
100 885	36.5 8210	65.5 14700	22.5 5060	20.2 4540	36.4 8180	1400	6 0.236	0.500 1.102
100 885	36.5 8210	65.5 14700	25.2 5670	28 6290	47.5 10700	1400	6 0.236	0.568 1.252
180 1590	43.3 9730	85.6 19200	30.5 6860	42.9 9640	64.7 14500	1200	8 0.315	1.035 2.282
180 1590	43.3 9730	85.6 19200	33.9 7620	65.8 14800	79.5 17900	1200	8 0.315	1.278 2.818
370 3270	65.1 14600	144 32400	42.7 9600	62.9 14100	95.3 21400	870	8 0.315	2.074 4.572
370 3270	65.1 14600	144 32400	47.1 10600	88.8 20000	115 25900	870	8 0.315	2.435 5.368

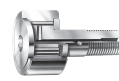

**FULL COMPLEMENT,
ECCENTRIC, WITH METAL
SEALS, STUD-TYPE
(G CUR...MM SERIES)
METRIC SERIES**

G CUR: crowned outer ring
G CURL: cylindrical outer ring

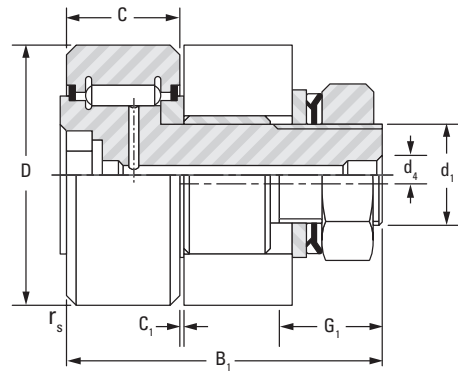

G CUR 35-52

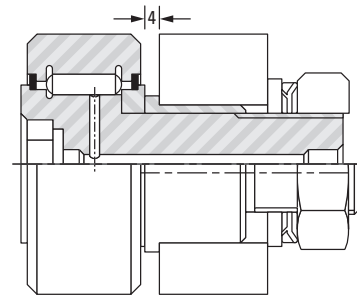

G CUR 62-130

Outer Dia. mm in	D mm in	d ₁ mm in	C mm in	C ₁ mm in	B ₁ mm in	G ₁ mm in	r _s min mm in	Crowned Designation	Cylindrical Designation
35 1.3780	35 1.3780	16 0.6299	18 0.709	0.85 0.033	52.3 2.059	17 0.669	0.6 0.024	G CUR 35 MM	
40 1.5748	40 1.5748	18 0.7087	20 0.787	0.85 0.033	58.3 2.295	19 0.748	1.0 0.039		G CURL 40 MM
52 2.0472	52 2.0472	20 0.7874	24 0.945	0.85 0.033	66.3 2.610	21 0.827	1.0 0.039	G CUR 52 MM	
62 2.4409	62 2.4409	24 0.9449	29 1.142	0.85 0.033	80.3 3.161	25 0.984	1.0 0.039	G CUR 62 MM	
72 2.8346	72 2.8346	24 0.9449	29 1.142	0.85 0.033	80.3 3.161	25 0.984	1.1 0.043	G CUR 72 MM	
80 3.1496	80 3.1496	30 1.1811	35 1.378	1.10 0.043	100.3 3.949	32 1.260	1.1 0.043	G CUR 80 MM	
90 3.5433	90 3.5433	30 1.1811	35 1.378	1.10 0.043	100.3 3.949	32 1.260	1.1 0.043	G CUR 90 MM	
100 3.9370	100 3.9370	36 1.4173	40 1.575	1.10 0.043	117.3 4.618	38 1.496	2.0 0.079	G CUR 100 MM	
110 4.3307	110 4.3307	36 1.4173	40 1.575	1.10 0.043	117.3 4.618	38 1.496	2.0 0.079	G CUR 110 MM	
120 4.7244	120 4.7244	42 1.6535	46 1.811	1.10 0.043	136.3 5.366	44 1.732	2.0 0.079	G CUR 120 MM	
130 5.1181	130 5.1181	42 1.6535	46 1.811	1.10 0.043	136.3 5.366	44 1.732	2.0 0.079	G CUR 130 MM	

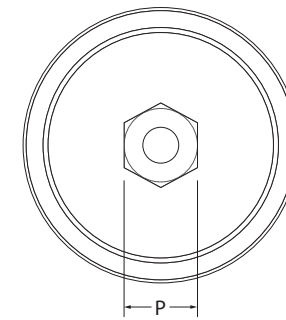

Hex Socket Roller End

Tightening Torque N-m lb-in	Load Ratings					Speed Rating Grease min ⁻¹	P Wrench mm	d ₄ mm in	Wt. kg lbs
	As a Bearing		As a Track Roller						
	C	C ₀	C _w	F _r perm	F _{0r} perm				
55 487	26.4 5930	32.4 7280	15.4 3460	7.25 1630	13.1 2940	2200	10	6 0.236	0.215 0.474
75 664	26.4 5930	32.4 7280	18.7 4200	12.1 2720	21.8 4900	2200	12	6 0.236	0.313 0.690
100 885	43.8 9850	57.9 13000	30.6 6880	21.2 4770	38.2 8590	1600	14	6 0.236	0.555 1.224
180 1593	63.7 14300	87.4 19600	44.1 9910	30.9 6950	55.6 12500	1400	12	6 0.236	1.022 2.253
180 1593	63.7 14300	87.4 19600	50.8 11400	52.7 11800	84.1 18900	1400	12	6 0.236	0.113 0.249
370 3275	100 22500	140 31500	66.8 15000	43.8 9850	78.8 17700	1000	14	8 0.315	0.182 0.401
370 3275	100 22500	140 31500	75.8 17000	68.1 15300	122 27400	1000	14	8 0.315	0.182 0.401
610 5399	115 25900	175 39300	82.1 18500	76.6 17200	135 30300	840	17	8 0.315	0.244 0.539
610 5399	115 25900	175 39300	89.7 20200	107 24100	161 36200	840	17	8 0.315	0.245 0.540
1000 8851	167 37500	240 54000	124 27900	107 24100	193 43400	740	19	8 0.315	0.328 0.724
1000 8851	167 37500	240 54000	133 30000	142 31900	228 51300	740	19	8 0.315	0.329 0.725

**CAGED, WITHOUT INNER RING,
NO END WASHERS,
YOKE-TYPE (RSTO SERIES)
METRIC SERIES**

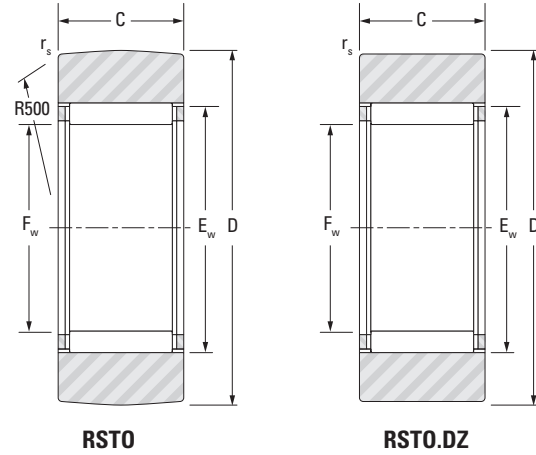

Outer Dia.	D	C	F _w	E _w	r _s min	Bearing Designation	Load Ratings					Speed Rating Grease	Wt.
							As a Bearing		As a Track Roller				
							Dynamic	Static	Dynamic		Static		
							C	C ₀	C _w	F _{r perm}	F _{0r perm}		
mm in	mm in	mm in	mm in	mm in	mm in	kN lbf		kN lbf			min ⁻¹	kg lbs	
16 0.6299	16 0.6299	7.8 0.307	7 0.2756	10 0.394	0.3 0.012	RSTO5A.TN RSTO5ADZ.TN	2.74 616	2.44 549	2.49 560	2.97 668	2.44 549	19000	0.009 0.020
19 0.7480	19 0.7480	9.8 0.386	10 0.3937	13 0.512	0.3 0.012	RSTO6 RSTO6DZ	5.40 1210	6.43 1450	4.15 933	4.04 908	5.63 1270	13000	0.014 0.031
24 0.9449	24 0.9449	9.8 0.386	12 0.4724	15 0.591	0.3 0.012	RSTO8 RSTO8DZ	5.85 1320	7.51 1690	4.79 1080	6.67 1500	7.44 1670	10000	0.023 0.051
30 1.1811	30 1.1811	11.8 0.465	14 0.5512	20 0.787	0.3 0.012	RSTO10 RSTO10DZ	10.40 2340	10.6 2380	8.62 1940	7.69 1730	10.6 2380	9400	0.044 0.097
32 1.2598	32 1.2598	11.8 0.465	16 0.6299	22 0.866	0.3 0.012	RSTO12 RSTO12DZ	11.20 2520	11.9 2680	8.80 1980	7.65 1720	10.9 2450	8100	0.049 0.108
35 1.3780	35 1.3780	11.8 0.465	20 0.7874	26 1.024	0.3 0.012	RSTO15 RSTO15DZ	12.90 2900	15.3 3440	9.13 2050	6.95 1560	11.2 2520	6300	0.052 0.115
40 1.5748	40 1.5748	15.8 0.622	22 0.8661	29 1.142	0.3 0.012	RSTO17 RSTO17DZ	19.00 4270	23.3 5240	13.8 3100	11.4 2560	18.2 4090	5800	0.095 0.209
47 1.8504	47 1.8504	15.8 0.622	25 0.9843	32 1.260	0.3 0.012	RSTO20 RSTO20DZ	20.00 4500	25.3 5690	15.3 3440	16.5 3710	22.2 4990	5000	0.134 0.295
52 2.0472	52 2.0472	15.8 0.622	30 1.1811	37 1.457	0.3 0.012	RSTO25 RSTO25DZ	22.40 5040	31.0 6970	16.0 3600	16.9 3800	23.7 5330	4100	0.155 0.342
62 2.4409	62 2.4409	19.8 0.780	38 1.4961	46 1.811	0.6 0.024	RSTO30 RSTO30DZ	33.30 7490	51.0 11470	22.3 5010	23.2 5220	34.2 7690	3200	0.258 0.569
72 2.8346	72 2.8346	19.8 0.780	42 1.6535	50 1.969	0.6 0.024	RSTO35 RSTO35DZ	35.20 7910	56.6 12720	25.2 5670	33.3 7490	43.0 9670	2900	0.37 0.816
80 3.1496	80 3.1496	19.8 0.780	50 1.9685	58 2.283	0.6 0.024	RSTO40 RSTO40DZ	38.80 8720	67.8 15240	25.9 5820	34.7 7800	45.0 10120	2400	0.430 0.948
85 3.3465	85 3.3465	19.8 0.780	55 2.1654	63 2.480	0.6 0.024	RSTO45	40.30 9060	73.5 16520	26.0 5850	35.8 8050	45.5 10230	2200	0.447 0.985
90 3.5433	90 3.5433	19.8 0.780	60 2.3622	68 2.677	0.6 0.024	RSTO50	41.80 9400	79.2 17800	26.0 5850	37.1 8340	45.8 10300	2000	0.495 1.091

**CAGED, WITH INNER RING,
NO END WASHERS
YOKE-TYPE (STO SERIES)
METRIC SERIES**

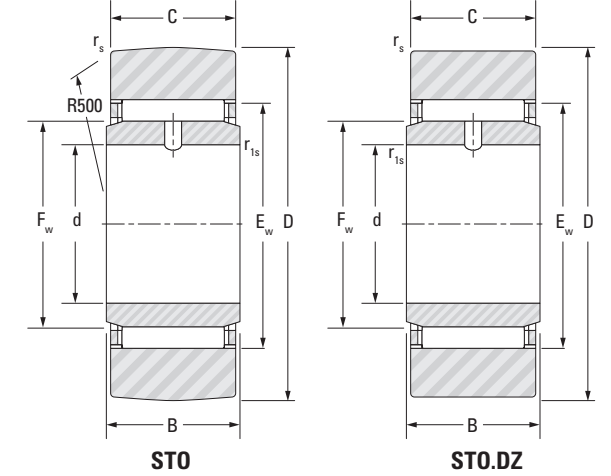

Outer Dia.	D	d	B	C	F _w	E _w	r _s	r _{1s} min	Bearing Designation	Load Ratings					Speed Rating Grease	Wt.
										As a Bearing		As a Track Roller				
										Dynamic	Static	Dynamic		Static		
										C	C ₀	C _w	F _{r perm}	F _{0r perm}		
mm in	mm in	mm in	mm in	mm in	mm in	mm in	mm in	mm in	kN lbf		kN lbf			min ⁻¹	kg lbs	
19 0.7480	19 0.7480	6 0.2362	10 0.394	9.8 0.386	10 0.3937	13 0.5118	0.3 0.012	0.3 0.012	STO6 STO6DZ	5.40 1210	6.43 1450	4.15 933	4.04 908	5.63 1270	9400	0.018 0.040
24 0.9449	24 0.9449	8 0.3150	10 0.394	9.8 0.386	12 0.4724	15 0.5906	0.3 0.012	0.3 0.012	STO8 STO8DZ	5.85 1320	7.51 1690	4.79 1080	6.67 1500	7.44 1670	8100	0.028 0.062
30 1.1811	30 1.1811	10 0.3937	12 0.472	11.8 0.465	14 0.5512	20 0.7874	0.3 0.012	0.3 0.012	STO10 STO10DZ	10.4 2340	10.6 2380	8.62 1940	7.69 1730	10.6 2380	6300	0.065 0.143
32 1.2598	32 1.2598	12 0.4724	12 0.472	11.8 0.465	16 0.6299	22 0.8661	0.3 0.012	0.3 0.012	STO12 STO12DZ	11.2 2520	11.9 2680	8.80 1980	7.65 1720	10.9 2450	5800	0.114 0.251
35 1.3780	35 1.3780	15 0.5906	12 0.472	11.8 0.465	20 0.7874	26 1.0236	0.3 0.012	0.3 0.012	STO15 STO15DZ	12.9 2900	15.3 3440	9.13 2050	6.95 1560	11.2 2520	5000	0.065 0.143
40 1.5748	40 1.5748	17 0.6693	16 0.630	15.8 0.622	22 0.8661	29 1.1417	0.3 0.012	0.3 0.012	STO17 STO17DZ	19.1 4290	23.3 5240	13.8 3100	11.4 2560	18.2 4090	4100	0.114 0.251
47 1.8504	47 1.8504	20 0.7874	16 0.630	15.8 0.622	25 0.9843	32 1.2598	0.3 0.012	0.3 0.012	STO20 STO20DZ	19.8 4450	25.3 5690	15.3 3440	16.5 3710	22.2 4990	3200	0.160 0.353
52 2.0472	52 2.0472	25 0.9843	16 0.630	15.8 0.622	30 1.1811	37 1.4567	0.3 0.012	0.3 0.012	STO25 STO25DZ	22.4 5040	31.0 6970	16.0 3600	16.9 3800	23.7 5330	2900	0.435 0.959
62 2.4409	62 2.4409	30 1.1811	20 0.787	19.8 0.780	38 1.4961	46 1.8110	0.6 0.024	0.6 0.024	STO30 STO30DZ	33.3 7490	51.0 11470	22.3 5010	23.2 5220	34.2 7690	2400	0.325 0.717
72 2.8346	72 2.8346	35 1.3780	20 0.787	19.8 0.780	42 1.6535	50 1.9685	0.6 0.024	0.6 0.024	STO35 STO35DZ	35.2 7910	56.6 12720	25.2 5670	33.3 7490	43.0 9670	2200	0.435 0.959
80 3.1496	80 3.1496	40 1.5748	20 0.787	19.8 0.780	50 1.9685	58 2.2835	0.6 0.024	1.0 0.039	STO40 STO40DZ	38.8 8720	67.8 15240	25.9 5820	34.7 7800	45.0 10120	2400	0.540 1.190
85 3.3465	85 3.3465	45 1.7717	20 0.787	19.8 0.780	55 2.1654	63 2.4803	0.6 0.024	1.0 0.039	STO45 STO45DZ	40.3 9060	73.5 16520	26.0 5850	35.8 8050	45.5 10230	2200	0.580 1.279
90 3.5433	90 3.5433	50 1.9685	20 0.787	19.8 0.780	60 2.3622	68 2.6772	0.6 0.024	1.0 0.039	STO50 STO50DZ	41.8 9400	79.2 17800	26.0 5850	37.1 8340	45.8 10300	2000	0.650 1.433

**FULL COMPLEMENT, NON-SEPARABLE,
SMALL SERIES, UNSEALED,
YOKE-TYPE (FP SERIES)
METRIC SERIES**

FP: crowned outer ring
FPL: cylindrical outer ring

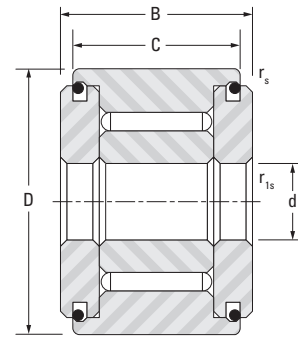

FP, FPL

Outer Dia.	D	d	C	B	r _s min	r _{1s} min	Designation		Load Ratings					Speed Rating Grease	Wt.
							Crowned Track Roller	Cylindrical Track Roller	As a Bearing		As a Track Roller				
									Dynamic	Static	Dynamic		Static		
									C	C ₀	C _w	F _{r perm}	F _{0r perm}		
mm in	mm in	mm in	mm in	mm in	mm in	mm in			kN lbf	kN lbf	min ⁻¹	kg lbs			
10 0.3937	10 0.3937	3 0.1181	8 0.315	8.7 0.343	0.2 0.008	0.15 0.006	FP 3 10	FPL 3 10	2.8 629	3.09 695	2.12 432	1.43 227	2.58 409	8500	0.004 0.009
11 0.4331	11 0.4331	3 0.1181	8 0.315	8.7 0.343	0.2 0.008	0.15 0.006	FP 3 11	FPL 3 11	2.8 629	3.09 695	2.12 477	1.43 321	2.58 580	8500	0.005 0.011
12 0.4724	12 0.4724	4 0.1575	9 0.354	9.7 0.382	0.2 0.008	0.15 0.006	FP 4 12	FPL 4 12	3.74 841	4.74 1070	2.54 571	1.63 366	2.94 661	6600	0.006 0.013
13 0.5118	13 0.5118	4 0.1575	9 0.354	9.7 0.382	0.2 0.008	0.15 0.006	FP 4 13	FPL 4 13	3.74 841	4.74 1070	2.16 486	2.75 618	3.89 874	6600	0.008 0.018
14 0.5512	14 0.5512	4 0.1575	9 0.354	10.2 0.402	0.3 0.012	0.15 0.006	FP 4 14	FLP 4 14	4.05 910	5.44 1220	2.86 643	2.26 508	4.07 915	5700	0.010 0.022
15 0.5906	15 0.5906	4 0.1575	9 0.354	10.2 0.402	0.3 0.012	0.15 0.006	FP 4 15	FLP 4 15	4.05 910	5.44 1220	3.04 683	2.83 636	4.65 1040	5700	0.011 0.024

**FULL COMPLEMENT,
NON-SEPARABLE,
SEALED OR UNSEALED,
YOKE-TYPE (FG SERIES)
METRIC SERIES**

FG: crowned outer ring
FGL: cylindrical outer ring

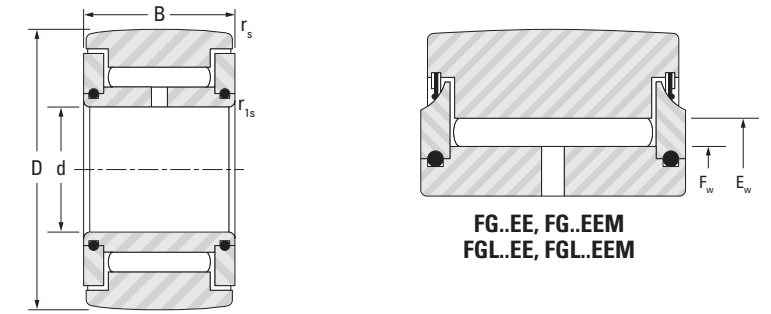

FG, FGL

FG..EE, FG..EEM
FGL..EE, FGL..EEM

Outer Dia.	D	d	B	F _w	E _w	r _s min	r _{1s} min	Designation		Load Ratings					Speed Rating Grease	Wt.
								Crowned Track Roller	Cylindrical Track Roller	As a Bearing		As a Track Roller				
										Dynamic	Static	Dynamic		Static		
										C	C ₀	C _w	F _{r perm}	F _{0r perm}		
mm in	mm in	mm in	mm in	mm in	mm in	mm in	mm in			kN lbf	kN lbf	min ⁻¹	kg lbs			
16 0.6299	16 0.6299	5 0.1969	12 0.472	7.7 0.3031	10.7 0.4213	0.3 0.012	0.3 0.012	FG 5 16	FGL 5 16	5.66 1270	6.51 1460	4.19 942	2.79 627	5.02 1130	5700	0.016 0.035
19 0.7480	19 0.7480	6 0.2362	12 0.472	9.7 0.3819	12.7 0.5000	0.3 0.012	0.3 0.012	FG 6 19	FGL 6 19	6.44 1450	8.15 1830	4.65 1050	3.49 785	6.28 1410	4400	0.019 0.042
24 0.9449	24 0.9449	8 0.3150	13 0.512	12.0 0.4724	15.0 0.5906	0.3 0.012	0.3 0.012	FG 8 24	FGL 8 24	7.3 1640	10.2 2290	5.45 1230	5.42 1220	8.63 1940	3500	0.037 0.082
	24 0.9449	8 0.3150	15 0.591	12.0 0.4724	15.0 0.5906	0.3 0.012	0.3 0.012	FG 8 24 15	FGL 8 24 15	9.08 2040	13.5 3030	6.76 1520	7.05 1580	11.4 2560	3500	0.044 0.097
30 1.1811	30 1.1811	10 0.3937	15 0.591	15.2 0.5984	20.2 0.7953	0.6 0.024	0.3 0.012	FG 10 30	FGL 10 30	14.2 3190	18.3 4110	10.3 2320	7.67 1720	13.8 3100	2900	0.066 0.146
32 1.2598	32 1.2598	12 0.4724	15 0.591	17.6 0.6929	22.6 0.8898	0.6 0.024	0.3 0.012	FG 12 32	FGL 12 32	15.5 3480	21.2 4770	10.5 2360	7.52 1690	13.5 3030	2400	0.077 0.170
35 1.3780	35 1.3780	15 0.5906	19 0.748	20.1 0.7929	25.2 0.9921	0.6 0.024	0.3 0.012	FG 15 35	FGL 15 35	22.5 5060	35.4 7960	14.6 3280	11.6 2610	20.9 4700	2100	0.103 0.227
40 1.5748	40 1.5748	17 0.6693	21 0.827	24.0 0.9449	30.0 1.1811	0.6 0.024	0.3 0.012	FG 17 40	FGL 17 40	29.9 6720	48.0 10800	18.5 4160	13.8 3100	24.8 5580	1800	0.155 0.342
47 1.8504	47 1.8504	20 0.7874	25 0.984	28.7 1.1299	34.7 1.3661	1.0 0.039	0.3 0.012	FG 20 47	FGL 20 47	36.5 8210	65.5 14700	22.5 5060	20.2 4540	36.4 8180	1400	0.295 0.650
52 2.0472	52 2.0472	25 0.9843	25 0.984	33.5 1.3189	39.5 1.5551	1.0 0.039	0.3 0.012	FG 25 52	FGL 25 52	39.7 8920	76.4 17200	23.1 5190	22.6 5080	40.3 9060	1200	0.310 0.683
62 2.4409	62 2.4409	30 1.1811	29 1.142	38.2 1.5039	44.2 1.7402	1.0 0.039	0.3 0.012	FG 30 62	FGL 30 62	46.5 10500	97.9 22000	28.9 6500	35.5 7980	58.2 13100	1100	0.490 1.080
72 2.8346	72 2.8346	35 1.3780	29 1.142	44.0 1.7323	50.0 1.9685	1.0 0.039	0.6 0.024	FG 35 72	FGL 35 72	50.0 11200	113 25400	31.4 7060	45.6 10300	68.4 15400	920	0.670 1.477
80 3.1496	80 3.1496	40 1.5748	32 1.260	49.7 1.9567	55.7 2.1929	1.0 0.039	0.6 0.024	FG 40 80	FGL 40 80	62.1 14000	155 38400	38.3 8610	63.7 14300	90.6 20400	810	0.890 1.962
85 3.3465	85 3.3465	45 1.7717	32 1.260	55.4 2.1811	61.4 2.4173	1.0 0.039	0.6 0.024	FG 45 85 EE	FGL 45 85	65.7 14800	173 38900	38.4 8630	67.2 15100	91.1 20500	720	0.970 2.138
90 3.5433	90 3.5433	50 1.9685	32 1.260	62.1 2.4449	68.1 2.6811	1.0 0.039	0.6 0.024	FG 50 90	FGL 50 90	69.7 15700	194 43600	37.8 8500	74.3 16700	88.7 19900	640	1.04 2.293
100 3.9370	100 3.9370	55 2.1654	36 1.417	70.0 2.7559	77.0 3.0315	1.5 0.059	0.6 0.024	FG 55 100	FGL 55 100	85.0 19100	233 52400	45.2 10200	87.9 19800	103 23200	570	1.35 2.976
110 4.3307	110 4.3307	60 2.3622	36 1.417	75.0 2.9528	82.0 3.2283	1.5 0.059	0.6 0.024	FG 60 110		88.6 19900	251 56400	48.9 11000	99.6 22400	119 26800	530	1.65 3.638
120 4.7244	120 4.7244	65 2.5591	42 1.654	80.0 3.1496	87.0 3.4252	1.5 0.059	0.6 0.024	FG 65 120	FGL 65 120	103 23200	310 69700	58.1 13100	131 29400	154 34600	490	2.35 5.181
125 4.9213	125 4.9213	70 2.7559	42 1.654	85.0 3.3465	92.0 3.6220	1.5 0.059	0.6 0.024	FG 70 125	FGL 70 125	106 23800	332 74600	58.7 13200	142 31900	157 35300	460	2.50 5.512

Continued on next page.

**FULL COMPLEMENT,
NON-SEPARABLE,
SEALED OR UNSEALED,
YOKE-TYPE (FG SERIES) – continued
METRIC SERIES**

FG: crowned outer ring
FGL: cylindrical outer ring

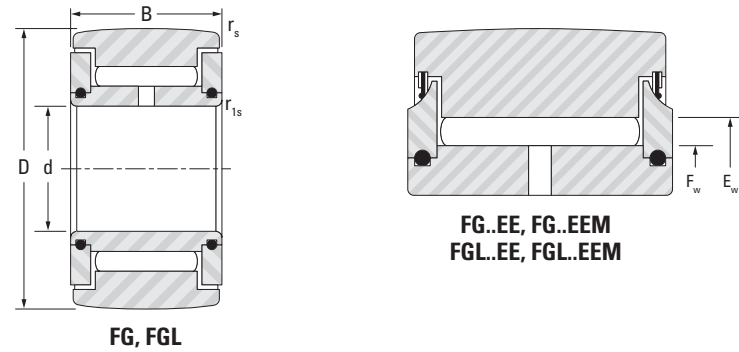

Outer Dia.	D	d	B	F _w	E _w	r _s min	r _{1s} min	Designation		Load Ratings					Speed Rating Grease	Wt.
								Crowned Track Roller	Cylindrical Track Roller	As a Bearing		As a Track Roller				
										Dynamic	Static	Dynamic	Static	Static		
mm in	mm in	mm in	mm in	mm in	mm in	mm in	mm in	C	C ₀	C _w	F _{r perm}	F _{0r perm}	min ⁻¹	kg lbs		
130 5.1181	130 5.1181	75 2.9528	42 1.654	90.0 3.5433	97.0 3.8189	1.5 0.059	0.6 0.024	FG 75 130		110 24700	354 79600	59.2 13300	155 34800	159 35700	440	2.65 5.842
140 5.5118	140 5.5118	80 3.1496	48 1.890	100.0 3.9370	108.0 4.2520	2.0 0.079	1.0 0.039	FG 80 140	FGL 80 140	140 31500	455 102000	72.4 13600	202 45400	189 42500	390	3.40 7.496
150 5.9055	150 5.9055	85 3.3465	48 1.890	107.0 4.2126	115.0 4.5276	2.0 0.079	1.0 0.039	FG 85 150		146 32800	490 110000	75.3 16900	227 51000	203 45600	370	4.00 8.818
160 6.2992	160 6.2992	90 3.5433	54 2.126	115.0 4.5276	123.0 4.8425	2.0 0.079	1.0 0.039	FG 90 160		168 37800	603 136000	85.7 19300	299 67200	244 54900	340	5.30 11.7
170 6.6929	170 6.6929	95 3.7402	54 2.126	120.0 4.7244	128.0 5.0394	2.0 0.079	1.0 0.039	FG 95 170		172 38700	629 141000	89.8 20200	308 69200	267 60000	330	6.00 13.2
180 7.0866	180 7.0866	100 3.9370	65 2.559	126.0 4.9606	136.0 5.3543	2.0 0.079	1.5 0.059	FG 100 180		238 53500	828 186000	126 28300	358 80500	363 81600	310	8.05 17.8
200 7.8740	200 7.8740	110 4.3307	65 2.559	140.0 5.5118	150.0 5.9055	2.0 0.079	1.5 0.059	FG 110 200		252 56700	922 207000	133 29900	427 96000	401 90100	280	10.00 22.0
215 8.4646	215 8.4646	120 4.7244	65 2.559	150.0 5.9055	160.0 6.2992	2.0 0.079	1.5 0.059	FG 120 215		261 58700	985 221000	138 31000	476 107000	430 96700	260	11.50 25.3
270 10.6299	270 10.6299	150 5.9055	78 3.071	186.0 7.3228	198.0 7.7953	3.0 0.118	1.5 0.059	FG 150 270		372 83600	1470 330000	200 456000	721 162000	658 148000	210	22.00 48.5

**FULL COMPLEMENT, NON-SEPARABLE,
LIGHT SERIES, WITH METAL SEALS
YOKE-TYPE (FGU...MM SERIES)
METRIC SERIES**

FGU: crowned outer ring
FGUL: cylindrical outer ring

FGU, FGUL

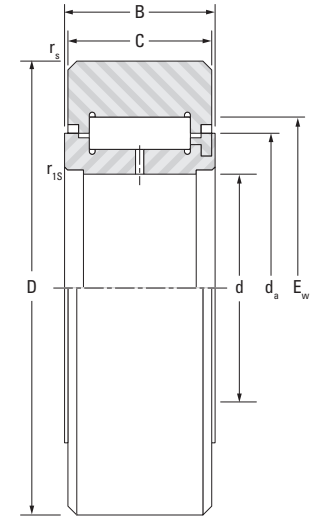

Outer Dia.	D	d	C	B	d _a	E _w	r _s min	r _{1s} min	Designation		Load Ratings			Speed Rating Grease	Wt.
									Crowned Track Roller	Cylindrical Track Roller	Dynamic		Static		
											C	F _{r perm}	F _{0r perm}		
mm in	mm in	mm in	mm in	mm in	mm in	mm in	mm in	mm in			kN lbf	min ⁻¹	kg lbs		
35 1.3780	35 1.3780	15 0.5906	18 0.709	19 0.748	20.4 0.8031	28.4 1.1181	0.6 0.024	0.3 0.012	FGU 15 35		7.80 1750	17.0 3820	17.0 3820	5700	0.096 0.212
35 1.3780	35 1.3780	15 0.5906	18 0.709	19 0.748	20.4 0.8031	28.4 1.1181	0.6 0.024	0.3 0.012	FGU 15 35 MM	FGUL 15 35 MM	7.80 1750	17.0 3820	17.0 3820	5700	0.096 0.212
40 1.5748	40 1.5748	17 0.6693	20 0.787	21 0.827	23.0 0.9055	31.0 1.2205	0.6 0.024	0.3 0.012	FGU 17 40 MM		11.5 2590	20.0 4500	21.5 4830	5200	0.142 0.313
47 1.8504	47 1.8504	20 0.7874	24 0.945	25 0.984	27.1 1.0669	37.1 1.4606	1.0 0.039	0.3 0.012	FGU 20 47 MM	FGUL 20 47 MM	15.5 3480	29.5 6630	32.3 7260	4400	0.235 0.518
52 2.0472	52 2.0472	25 0.9843	24 0.945	25 0.984	31.8 1.2520	41.8 1.6457	1.0 0.039	0.3 0.012	FGU 25 52		17.3 3890	31.5 7080	36.0 8090	3800	0.268 0.591
52 2.0472	52 2.0472	25 0.9843	24 0.945	25 0.984	31.8 1.2520	41.8 1.6457	1.0 0.039	0.3 0.012	FGU 25 52 MM	FGUL 25 52 MM	17.3 3890	31.5 7080	36.0 8090	3800	0.268 0.591
62 2.4409	62 2.4409	30 1.1811	28 1.102	29 1.142	38.2 1.5039	50.2 1.9764	1.0 0.039	0.3 0.012	FGU 30 62 MM		24.5 5510	44.5 10000	54.0 12100	3200	0.454 1.001
72 2.8346	72 2.8346	35 1.3780	28 1.102	29 1.142	45.9 1.8071	57.9 2.2795	1.0 0.039	0.6 0.024	FGU 35 72 MM	FGUL 35 72 MM	31.3 7040	50.0 11200	66.0 14800	2700	0.611 1.347
80 3.1496	80 3.1496	40 1.5748	30 1.181	32 1.260	51.6 2.0315	63.6 2.5039	1.0 0.039	0.6 0.024	FGU 40 80		40.6 9130	59.0 13300	84.0 18900	2400	0.822 1.812
80 3.1496	80 3.1496	40 1.5748	30 1.181	32 1.260	51.6 2.0315	63.6 2.5039	1.0 0.039	0.6 0.024	FGU 40 80 MM	FGUL 40 80 MM	40.6 9130	59.0 13300	84.0 18900	2400	0.822 1.812
110 4.3307	110 4.3307	60 2.3622	34 1.339	36 1.417	71.2 2.8031	87.2 3.4331	1.5 0.059	0.6 0.024	FGU 60 110 MM		64.0 14400	88.0 19800	129 29000	1800	1.625 3.583
120 4.7244	120 4.7244	65 2.5591	40 1.575	42 1.654	76.4 3.0079	92.4 3.6378	1.5 0.059	0.6 0.024	FGU 65 120		89.0 20000	110 24700	174 39100	1700	2.300 5.071
120 4.7244	120 4.7244	65 2.5591	40 1.575	42 1.654	76.4 3.0079	92.4 3.6378	1.5 0.059	0.6 0.024	FGU 65 120 MM		89.0 20000	110 24700	174 39100	1700	2.300 5.071
125 4.9213	125 4.9213	70 2.7559	40 1.575	42 1.654	81.5 3.2087	97.5 3.8386	1.5 0.059	0.6 0.024	FGU 70 125 MM		93.0 20900	110 24700	180 40500	1600	2.070 4.564
140 5.5118	140 5.5118	80 3.1496	46 1.811	48 1.890	91.7 3.6102	107.7 4.2402	2.0 0.079	1.0 0.039	FGU 80 140 MM		130 29200	138 31000	250 56200	1400	3.450 7.606
160 6.2992	160 6.2992	90 3.5433	52 2.047	54 2.126	101.8 4.0079	121.8 4.7953	2.0 0.079	1.0 0.039	FGU 90 160 MM		166 37300	188 42300	327 73500	1300	5.185 11.431
170 6.6929	170 6.6929	95 3.7402	52 2.047	54 2.126	108.2 4.2598	128.2 5.0472	2.0 0.079	1.0 0.039	FGU 95 170 MM		184 41400	198 44500	356 80000	1200	5.925 13.062
200 7.8740	200 7.8740	110 4.3307	63 2.480	65 2.559	124.1 4.8858	144.1 5.6732	2.0 0.079	1.5 0.059	FGU 110 200 MM		310 69700	280 62900	590 132600	1100	10.200 22.487
215 8.4646	215 8.4646	120 4.7244	63 2.480	65 2.559	133.6 5.2598	157.6 6.2047	2.0 0.079	1.5 0.059	FGU 120 215		310 69700	310 69700	600 134900	960	11.560 25.485

FULL COMPLEMENT, NON-SEPARABLE, HEAVY SERIES, WITH METAL SEALS YOKE-TYPE (FGU...MM SERIES)

METRIC SERIES

FGU: crowned outer ring
FGUL: cylindrical outer ring

FGU, FGUL

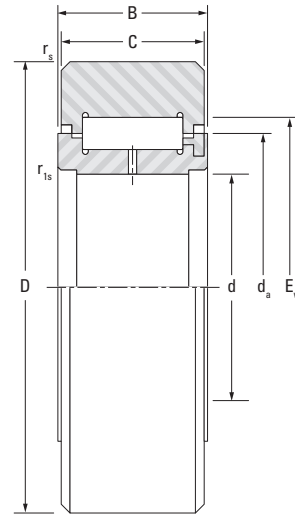

Outer Dia.	D	d	C	B	d _a	E _w	r _s min	r _{ts} min	Designation		Load Ratings					Speed Rating Grease	Wt.
									Crowned Track Roller	Cylindrical Track Roller	As a Bearing		As a Track Roller				
											Dynamic	Static	Dynamic	Static	Static		
									mm in	mm in	mm in	mm in	mm in	mm in	mm in		
42 1.6535	42 1.6535	15 0.5906	18 0.709	19 0.748	20.4 0.8031	28.4 1.1181	1.0 0.039	0.3 0.012	FGU 15 42	FGUL 15 42 MM	26.4 5930	32.4 7280	19.7 4430	14.7 3300	26.4 5930	2200	0.153 0.337
47 1.8504	47 1.8504	17 0.6693	20 0.787	21 0.827	20.0 0.7874	28.0 1.1024	1.0 0.039	0.3 0.012	FGU 17 47 MM	FGUL 17 47 MM	28.3 6360	36.5 8210	21.5 4830	18.8 4230	31.9 7170	1900	0.214 0.472
52 2.0472	52 2.0472	20 0.7874	24 0.945	25 0.984	27.1 1.0669	37.1 1.4606	1.0 0.039	0.3 0.012	FGU 20 52 MM	FGUL 20 52 MM	43.8 9850	57.9 13000	30.7 6900	21.3 4790	38.3 8610	1600	0.268 0.591
62 2.4409	62 2.4409	25 0.9843	24 0.945	25 0.984	31.8 1.2520	41.8 1.6457	1.0 0.039	0.3 0.012	FGU 25 62		48.2 10800	68.2 15300	35.1 7890	30.7 6900	55.1 12400	1400	0.435 0.959
72 2.8346	72 2.8346	30 1.1811	28 1.102	29 1.142	38.2 1.5039	50.2 1.9764	1.0 0.039	0.3 0.012	FGU 30 72 MM	FGUL 30 72 MM	70 15700	103 23200	49 11000	40 8990	72 16200	1100	0.681 1.501
80 3.1496	80 3.1496	35 1.3780	28 1.102	29 1.142	45.9 1.8071	57.9 2.2795	1.0 0.039	0.6 0.024	FGU 35 80	FGUL 35 80	77.5 17400	124 27900	51 11500	42.4 9530	76.3 17200	920	0.82 1.808
		80 3.1496	35 1.3780	28 1.102	29 1.142	45.9 1.8071	57.9 2.2795	1.0 0.039	FGU 35 80 MM		77.5 17400	124 27900	51 11500	42.4 9530	76.3 17200	920	0.82 1.808
90 3.5433	90 3.5433	40 1.5748	30 1.181	32 1.260	51.6 2.0315	63.6 2.5039	1.0 0.039	0.6 0.024	FGU 40 90 MM		89.2 20100	153 34400	60.2 13500	59.3 13300	107 24100	810	1.125 2.480
100 3.9370	100 3.9370	45 1.7717	30 1.181	32 1.260	55.4 2.1811	67.4 2.6535	1.5 0.059	0.6 0.024	FGU 45 100 MM		92.7 20800	165 37100	64.5 14500	73.6 16500	122 27400	750	1.395 3.075
110 4.3307	110 4.3307	50 1.9685	30 1.181	32 1.260	61.1 2.4055	73.1 2.8780	1.5 0.059	0.6 0.024	FGU 50 110		97.8 22000	182 40900	68.1 15300	85.9 19300	135 30300	680	1.683 3.710
		110 4.3307	50 1.9685	30 1.181	32 1.260	61.1 2.4055	73.1 2.8780	1.5 0.059	FGU 50 110 MM		97.8 22000	182 40900	68.1 15300	85.9 19300	135 30300	680	1.683 3.710
120 4.7244	120 4.7244	55 2.1654	34 1.339	36 1.417	66.1 2.6024	82.1 3.2323	1.5 0.059	0.6 0.024	FGU 55 120		128 28800	215 48300	88.7 19900	91.8 20600	159 35700	640	2.235 4.927
		120 4.7244	55 2.1654	34 1.339	36 1.417	66.1 2.6024	82.1 3.2323	1.5 0.059	FGU 55 120 MM	FGUL 55 120 MM	128 28800	215 48300	88.7 19900	91.8 20600	159 35700	640	2.235 4.927
130 5.1181	130 5.1181	60 2.3622	34 1.339	36 1.417	71.2 2.8031	87.2 3.4331	1.5 0.059	0.6 0.024	FGU 60 130 MM		133 29900	232 52200	93.4 21000	106 23800	175 39300	590	2.62 5.776
140 5.5118	140 5.5118	65 2.5591	40 1.575	42 1.654	76.4 3.0079	92.4 3.6378	2.0 0.079	0.6 0.024	FGU 65 140 MM		156 35100	290 65200	110 24700	142 31900	222 49900	540	3.56 7.848

Continued on next page.

FULL COMPLEMENT, NON-SEPARABLE, HEAVY SERIES, WITH METAL SEALS YOKE-TYPE (FGU...MM SERIES) – continued

METRIC SERIES

FGU: crowned outer ring
FGUL: cylindrical outer ring

FGU, FGUL

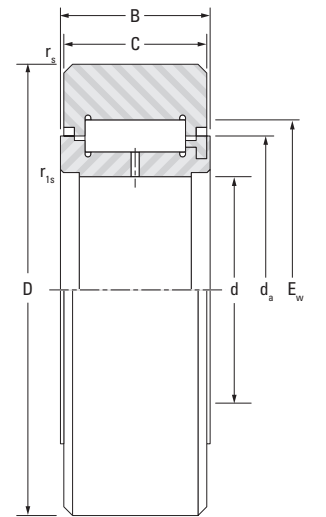

Outer Dia.	D	d	C	B	d _a	E _w	r _s min	r _{ts} min	Designation		Load Ratings					Speed Rating Grease	Wt.
									Crowned Track Roller	Cylindrical Track Roller	As a Bearing		As a Track Roller				
											Dynamic	Static	Dynamic	Static	Static		
									mm in	mm in	mm in	mm in	mm in	mm in	mm in		
150 5.9055	150 5.9055	70 2.7559	40 1.575	42 1.654	81.5 3.2087	97.5 3.8386	2.0 0.079	0.6 0.024	FGU 70 150 MM		161 36200	310 69700	115 25900	160 36000	240 54000	510	4.09 9.017
160 6.2992	160 6.2992	75 2.9528	40 1.575	42 1.654	86.6 3.4094	102.6 4.0394	2.0 0.079	0.6 0.024	FGU 75 160		166 37300	329 74000	119 26800	178 40000	257 57800	480	4.65 10.3
		160 6.2992	75 2.9528	40 1.575	42 1.654	86.6 3.4094	102.6 4.0394	2.0 0.079	FGU 75 160 MM		166 37300	329 74000	119 26800	178 40000	257 57800	480	4.65 10.3
170 6.6929	170 6.6929	80 3.1496	46 1.811	48 1.890	91.7 3.6102	107.7 4.2402	2.0 0.079	1.0 0.039	FGU 80 170		195 43800	412 92600	140 31500	229 51500	322 72400	450	6.07 13.4
		170 6.6929	80 3.1496	46 1.811	48 1.890	91.7 3.6102	107.7 4.2402	2.0 0.079	FGU 80 170 MM		195 43800	412 92600	140 31500	229 51500	322 72400	450	6.07 13.4
180 7.0866	180 7.0866	85 3.3465	46 1.811	48 1.890	95.5 3.7598	115.5 4.5472	2.0 0.079	1.0 0.039	FGU 85 180		224 50400	426 95800	162 36400	225 50600	340 76400	440	6.724 14.8
		180 7.0866	85 3.3465	46 1.811	48 1.890	95.5 3.7598	115.5 4.5472	2.0 0.079	FGU 85 180 MM	FGUL 85 180 MM	224 50400	426 95800	162 36400	225 50600	340 76400	440	6.724 14.8
190 7.4803	190 7.4803	90 3.5433	52 2.047	54 2.126	101.8 4.0079	121.8 4.7953	2.0 0.079	1.0 0.039	FGU 90 190 MM		259 58200	524 118000	186 41800	277 62300	412 92600	410	8.515 18.8
260 10.2362	260 10.2362	120 4.7244	63 2.480	65 2.559	133.6 5.2598	157.6 6.2047	3.0 0.118	1.5 0.059	FGU 120 260 MM		396 89000	875 197000	293 65900	540 121000	730 164000	300	19.750 43.6
300 11.8110	300 11.8110	140 5.5118	75 2.953	78 3.071	152.6 6.0079	176.6 6.9528	3.0 0.118	1.5 0.059	FGU 140 300 MM		493 111000	1210 272000	367 82500	818 184000	1020 229000	260	31.265 68.9

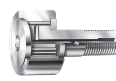

**FULL COMPLEMENT,
WITHOUT INNER RING,
UNSEALED, YOKE-TYPE
(RNA...B6, RNAB, RNAL SERIES)**

**SEPARATE INNER RINGS
(BIC SERIES)
METRIC SERIES**

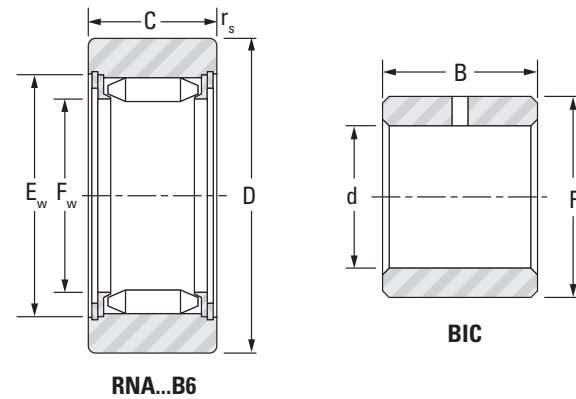

NOTES

RNA...B6: Crowned outer ring to maximum slope of 0.15%. Tolerance h9 on dimension D.

RNAB: Crowned outer ring to maximum slope of 1.5%. Tolerance h9 on dimension D.

RNAL: Cylindrical outer ring. Tolerance h7 on dim. D.

Outer Dia. mm in	D	C	F _w	E _w	r _{s min}	Track Roller Designations			Load Ratings					Speed Rating Grease min ⁻¹	Wt. kg lbs	Inner Ring Designation	F	B	d	r _{1s min}	Shaft Dia. mm in
									As a Bearing		As a Track Roller										
						Dynamic	Static	Dynamic	Static	Static	C _w	F _{r perm}	F _{0r perm}								
						C	C ₀	C _w	F _{r perm}	F _{0r perm}											
mm in	mm in	mm in	mm in	mm in	mm in	RNA...B6	RNAB	RNAL	kN lbf	kN lbf	kN lbf	kN lbf	min ⁻¹	kg lbs						mm in	
19 0.7480	19 0.7480	12 0.472	7.3 0.287	12.3 0.484	0.35 0.014	RNA 11005 B6	RNAB 11005		5.31 1190	4.44 998	4.82 1080	4.44 998	4.82 1080	6500	0.019 0.042						
22 0.8661	22 0.8661	12 0.472	9.7 0.382	14.7 0.579	0.35 0.014	RNA 11007 B6	RNAB 11007	RNAL 11007	6.42 1440	5.93 1330	5.5 1240	5.26 1180	6.55 1470	4700	0.022 0.049						
28 1.1024	28 1.1024	12 0.472	12.1 0.476	17.1 0.673	0.35 0.014	RNA 11009 B6	RNAB 11009	RNAL 11009	7.37 1660	7.42 1670	6.66 1500	7.42 1670	9.06 2040	3700	0.028 0.062						
32 1.2598	32 1.2598	15 0.591	17.6 0.693	22.6 0.890	0.35 0.014	RNA 11012 B6	RNAB 11012	RNAL 11012	12.7 2850	16.4 3690	9.38 2110	9.48 2130	13.7 3080	2400	0.032 0.071	BIC 1012	17.6 0.693	15 0.591	12 0.472	0.35 0.014	12 0.472
35 1.3780	35 1.3780	15 0.591	20.8 0.819	25.8 1.016	0.65 0.026	RNA 11015 B6	RNAB 11015		13.9 3120	19.4 4360	9.60 2160	9.47 2130	14.1 3170	2000	0.035 0.077	BIC 1015	20.8 0.819	15 0.591	15 0.591	0.65 0.026	15 0.591
42 1.6535	42 1.6535	15 0.591	23.9 0.941	28.9 1.138	0.65 0.026	RNA 11017 B6	RNAB 11017	RNAL 11017	15.0 3370	22.4 5040	11.0 2470	14.4 3240	18.4 4140	1700	0.042 0.093	BIC 1017	23.9 0.941	15 0.591	17 0.669	0.65 0.026	17 0.669
47 1.8504	47 1.8504	18 0.709	28.7 1.130	34.7 1.366	0.65 0.026	RNA 11020 B6	RNAB 11020	RNAL 11020	21.7 4880	33.5 7530	14.6 3280	16.0 3600	23.3 5240	1400	0.047 0.104	BIC 2020	28.7 1.130	18 0.709	20 0.787	0.65 0.026	20 0.787
52 2.0472	52 2.0472	18 0.709	33.5 1.319	39.5 1.555	0.65 0.026	RNA 11025 B6	RNAB 11025		23.6 5310	39.1 8790	15.0 3370	17.1 3840	24.4 5490	1200	0.052 0.115	BIC 1025	33.5 1.319	18 0.709	25 0.984	0.65 0.026	25 0.984
62 2.4409	62 2.4409	22 0.866	38.2 1.504	44.2 1.740	0.65 0.026	RNA 11030 B6	RNAB 11030		34.2 7690	65.8 14800	22.6 5080	32.8 7370	44.3 9960	1100	0.062 0.137	BIC 2030	38.2 1.504	22 0.866	30 1.181	0.65 0.026	30 1.181
72 2.8346	72 2.8346	22 0.866	44.0 1.732	50.0 1.969	0.65 0.026	RNA 11035 B6			36.7 8250	75.7 17000	24.6 5530	42.4 9530	52.2 11700	920	0.072 0.159	BIC 2035	44 1.732	22 0.866	35 1.378	0.65 0.026	35 1.378
80 3.1496	80 3.1496	22 0.866	49.7 1.957	55.7 2.193	0.85 0.033		RNAB 11040		39.2 8810	85.6 19200	25.8 5800	48.7 10900	57.0 12800	810	0.080 0.176	BIC 2040	49.7 1.957	22 0.866	40 1.575	0.85 0.033	40 1.575
90 3.5433	90 3.5433	24 0.945	62.1 2.445	68.1 2.681	0.85 0.033	RNA 11050 B6			44.0 9890	107 24100	25.8 5800	53.1 11900	57.0 12800	640	0.090 0.198	BIC 11050	62.1 2.445	24 0.945	50 1.969	0.85 0.033	50 1.969

STUD-TYPE AND YOKE-TYPE TRACK ROLLERS – FULL COMPLEMENT

INCH SERIES

Inch series track rollers listed in this catalog have been designed with the outer rings of large radial cross section to withstand heavy rolling or shock loads on track-type or cam-controlled equipment.

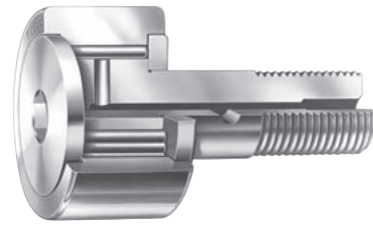

Fig. B-61. CR with stud



Fig. B-62. YCR for yoke mounting

REFERENCE STANDARD:

- **ANSI/ABMA Std. 18.2** – needle roller bearings – radial, inch design.

Before selecting specific inch series track rollers, the engineering section in this catalog should be reviewed.

Table B-38. Identification code – inch series

Prefix letters			Suffix numbers			Complete
Type	Plus	Construction features	Plus size	O.D.	Equals	Designation
CR	plus	SBE	plus	-16	equals	CRSBE-16
CR	plus			-16	equals	CR-16

Table B-39. Code description – inch series

Stud-types	
Description	Prefix code
With seals and internal thrust washers	CRS
With seals, internal thrust washers and crowned outer ring	CRSC
With seals, internal thrust washers, hex socket and crowned outer ring	CRSBC
With seals, internal thrust washers, hex socket, crowned outer ring and eccentric stud	CRSBCE
Yoke-types	
With seals and internal thrust washers	YCRS
With seals, internal thrust washers and profiled outer ring	YCRSC

IDENTIFICATION

The stud- and yoke-type, special construction features and size are designated by an identification code consisting of prefix letters followed by a dash and suffix numbers.

The initial prefix letters denote the type of track roller/cam follower. Additional prefix letters are used when it is necessary to denote special construction features. The suffix numbers following the prefix letters denote the size of the track roller. See Table B-38.

The basic types are listed below:

- CR – regular stud-type, full complement needle rollers, inch series
- YCR – yoke-type, full complement needle rollers, inch series

Construction feature code letters – for inch series track rollers – are used as required, in the following order:

- S – seals with internal thrust washers
- B – hexagonal wrench socket in stud head (stud-type only)
- C – crowned outer ring
- E – eccentric stud (stud-type only)

Descriptions of typical examples, with complete letter codes, combining basic type of bearing and construction features follow. See Table B-39.

Since the entire identification code might not appear on the bearing itself, the manufacturer’s parts list or another reliable source should always be consulted when ordering bearings for field or service replacement to make certain the correct unit with the correct lubricant is specified.

CONSTRUCTION

JTEKT products listed on the following pages have been designed with the outer ring of the large radial cross section to withstand heavy rolling and shock loads on track-type or cam-controlled equipment.

Regular stud-type (CR) are designed with integral studs for cantilever mounting. When a regular stud-type track roller is used within the permissible dynamic load ($F_{r perm}$) given in the bearing tables, the ductile core of the stud provides the necessary toughness for and resistance to shock loads. A screwdriver slot or a hexagonal wrench socket, in the head of the stud, facilitates mounting.

Yoke-type (YCR) are designed for straddle mounting. Each type is available with a full complement of needle rollers.

All inch series track rollers have a black-oxide finish on all external surfaces.

SEALED TRACK ROLLERS – INCH SERIES

Inch series sealed track rollers contain a lip-type seal and an internal thrust washer. On some sizes of track rollers, the thrust washer and seal have been incorporated into a single component. Regardless of configuration, the thrust washer fits between the shoulders of the outer ring. The inside faces the steel retaining washer and flange of the stud. These washers reduce sliding friction and serve to increase the life of the bearing – particularly when it is infrequently re-lubricated, or where misalignment occurs. In all cases, the external dimensions of the sealed bearings are the same as the unsealed bearings. The seals are thermally stable in a temperature range between -30° C and +110° C (-25° F and +225° F).

CROWNED TRACK ROLLERS

These units are available with cylindrical or crowned outer rings.

Track rollers are designed with a crowned outer ring to alleviate the uneven bearing loading – resulting from deflection, bending or misalignment in mounting.

To specify a crowned ring for any inch series track roller having a cylindrical outer ring, add the letter “C” at the end of the prefix code. For example:

- prefix CR** – regular stud-type, full complement of needle rollers and cylindrical outer ring
- prefix CRC** – same as above, but with crowned outer ring.

The O.D. tolerance of crowned track rollers is 0.000 – 0.050 mm (+0.0000 - 0.0020 in). The crown radii are listed in Table B-40.

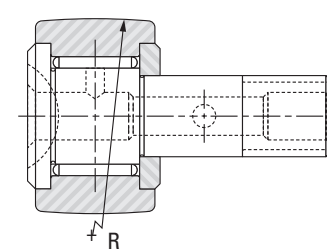

Fig. B-63. CR with stud

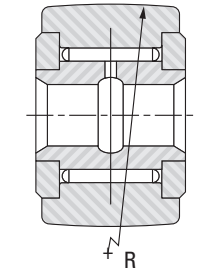

Fig. B-64. YCR for yoke mounting

Table B-40. Crown radius for types CRC, CRSC, CRSBC, YCRC, YCRSC

Size designation (suffix)	R		Size designation (suffix)	R	
	Crown radius (approx.)			Crown radius (approx.)	
	mm	in		mm	in
-8	152.400	6.0000	-28	508.000	20.0000
-8-1	177.800	7.0000	-30	508.000	20.0000
-10	177.800	7.0000	-32	609.600	24.0000
-10-1	203.200	8.0000	-36	609.600	24.0000
-12	254.000	10.0000	-40	762.000	30.0000
-14	254.000	10.0000	-44	762.000	30.0000
-16	304.800	12.0000	-48	762.000	30.0000
-18	304.800	12.0000	-52	762.000	30.0000
-20	355.600	14.0000	-56	762.000	30.0000
-22	355.600	14.0000	-64	762.000	30.0000
-24	508.000	20.0000			
-26	508.000	20.0000			

HEXAGONAL SOCKETS

Smaller sizes of regular inch series stud-type units have a screwdriver slot or a hexagonal socket in the flanged end of the stud to facilitate mounting. Larger sizes have a socket to accommodate a hexagonal wrench. Wrench sizes are listed in Table B-41 on page B-252.

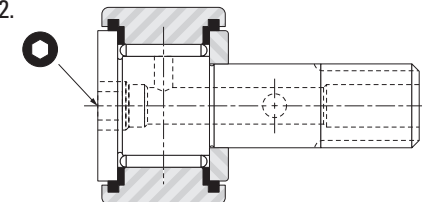

Fig. B-65. Inch series stud-type unit with hexagonal socket

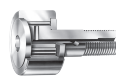

Table B-41. Hexagonal wrench sizes – inch series

Size designation (suffix)	Wrench size	Size designation (suffix)	Wrench size
	mm in		mm in
-8	3.175 0.1250	-28	7.937 0.3125
-8-1	3.175 0.1250	-30	7.937 0.3125
-10	3.175 0.1250	-32	11.112 0.4375
-10-1	3.175 0.1250	-36	11.112 0.4375
-12	4.762 0.1875	-40	12.700 0.5000
-14	4.762 0.1875	-44	12.700 0.5000
-16	6.350 0.2500	-48	19.050 0.7500
-18	6.350 0.2500	-52	19.050 0.7500
-20	6.350 0.2500	-56	19.050 0.7500
-22	6.350 0.2500	-64	19.050 0.7500
-24	7.937 0.3125	-80	22.225 0.875
-26	7.937 0.3125	-96	25.40 1.000

ECCENTRIC STUDS

To provide radial adjustment of the outer ring toward the track or cam surface at the time of installation, the regular inch series stud-types are available with eccentric studs which are specified by adding the letter “E” to the construction feature code:

prefix CRSBE – regular stud-type track roller with full complement of needle rollers, two seals, with internal thrust washers, hexagonal wrench socket in stud head, and eccentric stud.

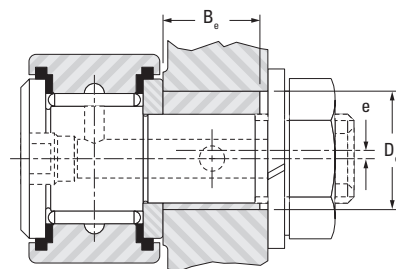

Fig. B-66. Eccentric studs – inch series

Pertinent dimensions of the eccentric stud are listed in Table B-42.

Since a track roller with an eccentric stud is usually adjusted upon installation by turning the stud in the mounting hole, a close clearance fit between the outer diameter of the bushing and the mounting hole is necessary. For turning the stud, a hexagonal

wrench is generally more convenient than a screwdriver. And an option for a hexagonal wrench socket, in the head of the stud, should be exercised.

Some applications may require more secure positioning than provided by the tightened stud nut. If so, it is suggested that the housing, and eccentric bushing, be drilled at the time of installation to accept a locating dowel pin.

Table B-42. Eccentric bushing dimensions regular stud-type (type CR)

Size designation (suffix)	D _e Bushing O.D. +0.001, -0.001 mm in	B _e Bushing width +0.000, -0.010 mm in	e Eccentricity mm in
-8-1	6.350 0.250	9.525 0.375	0.254 0.010
-10-1	9.525 0.375	11.100 0.437	0.381 0.015
-12	12.700 0.500	12.700 0.500	0.381 0.015
-14	12.700 0.500	12.700 0.500	0.381 0.015
-16	15.875 0.625	12.700 0.500	0.762 0.030
-18	15.875 0.625	12.700 0.500	0.762 0.030
-20	17.450 0.687	15.875 0.625	0.762 0.030
-22	17.450 0.687	15.875 0.625	0.762 0.030
-24	22.225 0.875	19.050 0.750	0.762 0.030
-26	22.225 0.875	19.050 0.750	0.762 0.030
-28	25.400 1.000	22.225 0.875	0.762 0.030
-30	25.400 1.000	22.225 0.875	0.762 0.030
-32	30.150 1.187	25.400 1.000	0.762 0.030
-36	30.150 1.187	25.400 1.000	0.762 0.030
-40	34.925 1.375	28.575 1.125	0.762 0.030
-44	34.925 1.375	28.575 1.125	0.762 0.030
-48	44.450 1.750	31.750 1.250	1.524 0.060
-52	44.450 1.750	31.750 1.250	1.524 0.060
-56	46.025 1.812	34.925 1.375	1.524 0.060
-64	50.800 2.000	50.800 2.000	1.524 0.060

- To ensure proper clamping of the stud, the housing should be slightly wider than the maximum width of the eccentric bushing.

- Diameter of bushing mounting hole should be D_E plus 0.002/0.003 in (.051-0.0102mm).

LOAD RATINGS

DYNAMIC LOADING AS A TRACK ROLLER

When the outer ring of a stud-type or yoke-type track roller runs on a track, the contact under a radial load causes elastic (oval) deformation of the outer ring. As a result, a smaller zone of the raceway is loaded and the load is distributed on fewer needle rollers. This, in turn, affects the track roller’s dynamic and static load ratings. Also, this deformation generates bending stress in the outer ring, which must not exceed the maximum permitted for the material of the outer ring. The maximum permissible dynamic (F_{r perm}) radial load condition is determined by this requirement.

The rating life of a stud-type or yoke-type track roller should be calculated using the dynamic load ratings, C_w, shown in the tables. The tables also show the maximum permissible radial load, F_{r perm}, that can be dynamically applied on the stud-type or yoke-type track rollers. However, to calculate the L₁₀ life of a track roller, the applied radial load must not be greater than C_w/4 – based on ideal operating conditions of alignment, lubrication, temperature, speed and accelerations.

STATIC LOADING

In addition to the basic static load rating C₀, the tables also list the maximum permissible static radial load, F_{0r perm}, that may be applied to a stud-type or yoke-type track roller. The values of F_{0r perm} result in a minimum static factor f_s of 0.7, for the worst condition of internal load distribution in inch series track roller operation. **The F_{0r perm} values must not be exceeded.** Exceeding F_{0r perm} may cause permanent damage to the track roller. A damaged track roller could cause the equipment in which the track roller is installed to malfunction. The static factor f_s can be calculated using the following formula:

$$f_s \geq 0.7 \left(\frac{F_{0r \text{ perm}}}{P_{0r}} \right)$$

Where:

- F_{0r perm} = Maximum permissible static radial load
- P_{0r} = Equivalent static load (F_{0r} for yoke-type track rollers)
- F_{0r} = Static radial load
- f_s = Static factor whose values should not be smaller than those suggested in Table B-43.

Table B-43. Suggested values for static factors f_s for inch series track rollers

Requirements for yoke – type track rollers and stud – type track rollers	Suggested f _s values	
	Max.	Min.
High shock-type loads – Quiet running	1.5	2.5
Normal loading – Normal quietness of running	1	1.5
Minor impact loads and rotary motion particularly quiet running not required	0.7	1

MOUNTING

The surface of the hole in the machine element, which supports the stud or the mounting shaft, must not deform under the expected load, and the support should be sufficiently rigid to resist bending loads.

Deformation and bending will cause uneven loading of the outer ring.

In mounting the stud-type track roller, the retaining washer must be firmly backed up by a flat shoulder which is square with the stud center line. The shoulder diameter must be no smaller than the minimum clamping diameter (d_a) listed in the bearing tables.

The maximum inherent strength of the stud is obtained when the unit is supported, as close as possible, to the retaining washer – which minimizes the bending moment. For this reason, the edge of the housing, which supports the stud shank, should be kept as sharp as possible, but free from burrs.

To minimize deflection in mounted stud-type track rollers, the stud shank should be housed with the fit (d_b) shown in the bearing tables. The clamping nut should not be tightened with a torque value higher than the maximum listed. A screwdriver slot, or hexagonal socket in the end of the stud, is provided for a tool to prevent the stud from turning when the nut is being tightened. Because the bottom of the screwdriver slot is not flat, it is helpful to put a radius on the tip of the screwdriver being used to hold the stud more securely.

When the stud shank is housed with an interference fit, installation force should be applied only to the center portion of the flanged end of the stud, preferably with an arbor press.

When the loads are high, the yoke-type track rollers should be mounted on a high strength bolt or shaft with the tight transition fit listed in the bearing tables. The bearing should be clamped between flat and parallel faces, at right angles, to the axis to prevent the retaining washers from coming off under load. If the bearing cannot be clamped, a close axial fit in the yoke is required.

When the applied loads are light to moderate, the inner ring of a yoke-type track roller may be mounted on an unhardened shaft, or a bolt with the loose transition fit listed in the bearing tables. Again, the retaining washers should be backed up axially to prevent their coming off under load.

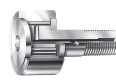

LUBRICATION

All inch series stud-type track rollers with a screwdriver slot in the flanged end of the stud have provisions for lubrication, through the flanged end of the stud. The 12, and larger sizes of inch series stud-type track rollers with screwdriver slots, have provisions for re-lubrication through either end of the stud, and through a cross-drilled hole in the shank. The ends of the axial holes are counterbored to accept drive-type grease lubrication fittings. Hole diameters for these grease fittings are listed in the tables of dimensions.

Sizes 8 through 10-1 of the inch series stud-type track rollers, with a hexagonal socket in the flanged end of the stud, cannot be re-lubricated. Size 12 and up have re-lubrication provisions in the threaded end of the stud, and a cross-drilled hole in the shank. At the threaded end of the stud, the axial hole is counterbored to receive a drive type grease fitting. Sizes 12 through 22 and 48 through 64 of inch series stud-type track rollers, with hexagonal sockets, also have provisions for re-lubrication through the hex socket in the flanged end of the stud. Sizes 48 through 64 are supplied with lubrication fittings which may be installed in the axial hole in the bottom of the hexagonal slot in the head end of the stud – at a depth which allows the hexagonal wrench to be inserted in the wrench socket, without damaging the grease fitting.

Plugs are furnished with stud-type track rollers to close off unused holes. If the cross-drilled hole in the stud shank is not used, it will be covered when the track roller is installed properly.

Most inch series yoke-type track rollers are produced with lubrication holes and grooves in the inner ring bores, so they can be re-lubricated through axially and radially drilled holes in the supporting shaft or bolt.

Oil is the preferred lubricant for all types. Use continuous oil lubrication, or frequent grease lubrication for steady rotating conditions. Applications involving slow, intermittent oscillation are not as critical. And longer intervals between re-lubrication are permissible. Both stud- and yoke-type track rollers are normally supplied with medium temperature grease lubrication.

SPECIAL TRACK ROLLERS/ CAM FOLLOWERS

Track rollers can be obtained with dimensions different from those in the bearing tables, if the quantities permit economical production. For these and other modifications, please consult your representative.

FORKLIFT TRUCK

Yoke-type sealed units serve as high capacity and rugged guide rollers for lift trucks. Their design permits them to be mounted on studs welded to the structure. The seals exclude foreign matter and extend the time between re-lubrication periods.

HAY BALER

Stud-types are important components on many different types of farm equipment because of their required long service life under severe loads and operating conditions. Needle roller bearings provide dependable and economical operation in the windrow pickup of hay balers.

MACHINE WAY

Heavily loaded machine tool tables must travel freely and accurately. Stud- and yoke-type sealed units, in combination, support and guide such tables under the most severe conditions. The high capacity and the very low wear rate permit heavy loads to be carried without impairing the accuracy of the table's travel. The seals exclude dirt and chips, and make the need for re-lubrication infrequent.

RECIPROCATING SLIDE

Stud-types find wide application in feeding and advancing mechanisms on metalworking presses. The rotary motion of an eccentric cam, rotating between two cam followers, mounted on a slide imparts reciprocating linear motion to the slide. Dwell periods, as well as accuracy in both rapid and slow linear actuation of the slide, are made possible.

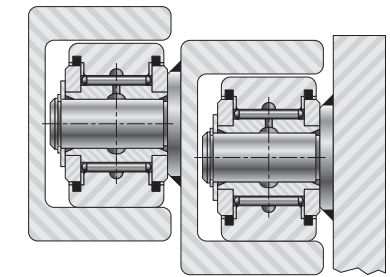

Fig. B-67. Yoke-type sealed units

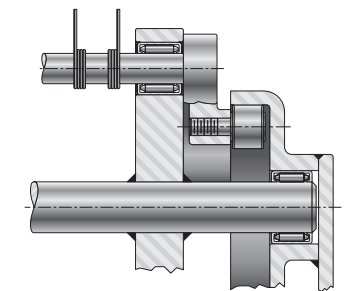

Fig. B-68. Stud-type

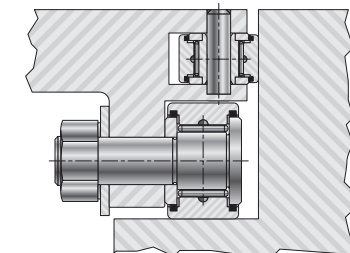

Fig. B-69. Stud- and yoke-type sealed units

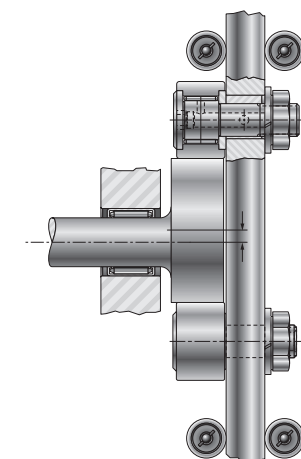

Fig. B-70. Stud-type

**STUD-TYPE TRACK ROLLERS
CR, CRS SERIES**

INCH SERIES

- Screwdriver slot in head facilitates mounting.
- Non-separable, sealed unit with outer ring, full complement of needle rollers, stud seals, self-lubricating resin internal thrust washers, and stud-fastened retaining washer.
- Seals help retain lubricant and exclude foreign matter (CRS Series).
- Re-lubrication via axially drilled hole through stud with cross-drilled holes in stud raceway and shank.
- Recessed axial hole accepts standard nominal inch drive-type grease lubrication fitting.
- Lubrication fitting plugs furnished to close off unused holes.

- Tolerance limits for outer diameters of stud and outer ring refer to "single mean diameter."
- A close fit between stud and hole required for mounting.
- Bore dimensions given below result in varying fit (0.025 mm (0.0010 in) tight to 0.013 mm (0.0005 in) loose).
- Retaining washer should be firmly backed up by flat housing shoulder (perpendicular to the stud axis).
- Shoulder diameter should be at least same size as minimum clamping diameter listed.
- May be mounted with two thin lock nuts, or nut and lock washer.

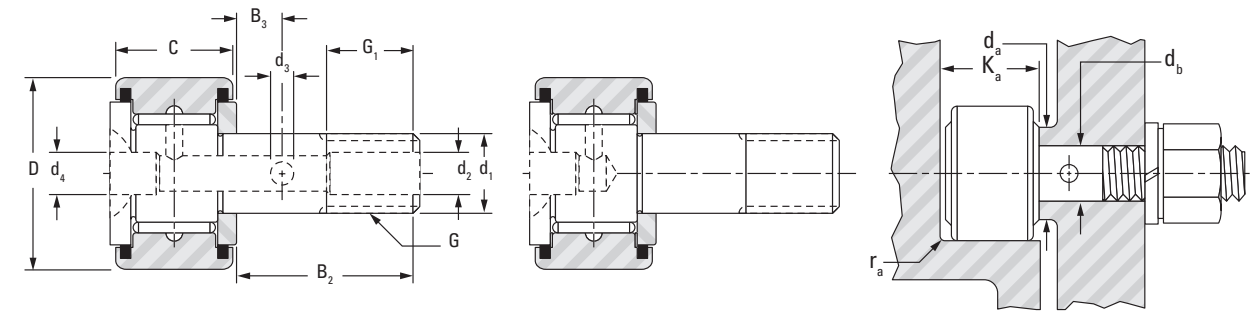

CR and CRS -12 to -64

CR and CRS -8 to -10-1

NOTE

Clamping torque is based on lubricated threads. If threads are dry, the torque values listed below may be doubled.

Outer Dia.	d ₁		D		C		B ₂		G ₁	G	Track Roller Designation					
	+0.025 +0.0010 -0 -0.0000		+0 +0.000 -0.025 -0.001		+0 +0.000 -0.13 -0.005		(nom.)				Min.	d ₂ and d ₄	d ₃	UNF	Without Seals	With Seals and Internal Thrust Washers
	mm	in	mm	in	mm	in	mm	in								
1/2	4.826 0.1900	12.70 0.500	8.74 0.344	12.70 0.500	6.35 0.250	3.18 ⁽²⁾ 0.125 ⁽¹⁾	—	10-32	CR-8	CRS-8						
	4.826 0.1900	12.70 0.500	9.53 0.375	15.88 0.625	6.35 0.250	3.18 ⁽²⁾ 0.125 ⁽¹⁾	—	10-32	CR-8-1	CRS-8-1						
5/8	6.350 0.2500	15.88 0.625	10.31 0.406	15.88 0.625	7.92 0.312	3.18 ⁽²⁾ 0.125 ⁽¹⁾	—	1/4-28	CR-10	CRS-10						
	6.350 0.2500	15.88 0.625	11.13 0.438	19.05 0.750	7.92 0.312	3.18 ⁽²⁾ 0.125 ⁽¹⁾	—	1/4-28	CR-10-1	CRS-10-1						
3/4	9.525 0.3750	19.05 0.750	12.70 0.500	22.23 0.875	6.35 0.250	3.18 0.188	2.39 0.094	3/8-24	CR-12	CRS-12						
7/8	9.525 0.3750	22.23 0.875	12.70 0.500	22.23 0.875	6.35 0.250	3.18 0.188	2.39 0.094	3/8-24	CR-14	CRS-14						
1	11.113 0.4375	25.40 1.000	15.88 0.625	25.40 1.000	6.35 0.250	12.70 0.500	3.18 0.188	7/16-20	CR-16	CRS-16						
1 1/8	11.113 0.4375	28.58 1.125	15.88 0.625	25.40 1.000	6.35 0.250	12.70 0.500	3.18 0.188	7/16-20	CR-18	CRS-18						
1 1/4	12.700 0.5000	31.75 1.250	19.05 0.750	31.75 1.250	7.92 0.312	15.88 0.625	3.18 0.188	1/2-20	CR-20	CRS-20						
1 3/8	12.700 0.5000	34.93 1.375	19.05 0.750	31.75 1.250	7.92 0.312	15.88 0.625	3.18 0.188	1/2-20	CR-22	CRS-22						
1 1/2	15.875 0.6250	38.10 1.500	22.23 0.875	38.10 1.500	9.53 0.375	19.05 0.750	3.18 0.188	5/8-18	CR-24	CRS-24						
1 5/8	15.875 0.6250	41.28 1.625	22.23 0.875	38.10 1.500	9.53 0.375	19.05 0.750	3.18 0.188	5/8-18	CR-26	CRS-26						
1 3/4	19.050 0.7500	44.45 1.750	25.40 1.000	44.45 1.750	11.13 0.438	22.23 0.875	3.18 0.188	3/4-16	CR-28	CRS-28						
1 7/8	19.050 0.7500	47.63 1.875	25.40 1.000	44.45 1.750	11.13 0.438	22.23 0.875	3.18 0.188	3/4-16	CR-30	CRS-30						

⁽¹⁾ No lubrication hole in threaded end.
⁽²⁾ Oil hold (d₄) only.

Load Ratings					Speed Rating Grease	Mounting Dimensions				Clamping Torque	Approx. Wt.
As a Bearing		As a Track Roller				d _b	r _{as max}	K _a	d _a		
Dynamic	Static	Dynamic	Static								
C	C ₀	C _w	F _{r perm}	F _{0r perm}	Bore Dia. for Stud +0.013 +0.0005 -0 -0.0000	Max.	Min.	Min.			
kN lbf	kN lbf	kN lbf	kN lbf	kN lbf	mm in	mm in	mm in	mm in	N-m lb-in	kg lbs	
4.44 999	4.94 1110	3.01 677	1.04 233	2.49 560	7000	4.826 0.1900	0.25 0.010	10.41 0.41	7.52 0.296	1.69 15	0.010 0.022
4.98 1120	5.69 1280	3.38 759	1.21 272	2.90 652	7000	4.826 0.1900	0.25 0.010	11.18 0.44	7.52 0.296	1.69 15	0.010 0.023
6.05 1360	7.87 1770	4.37 982	2.26 508	5.43 1220	5500	6.350 0.2500	0.38 0.015	11.94 0.47	9.12 0.359	3.95 35	0.019 0.041
6.58 1480	8.76 1970	4.76 1070	2.53 569	6.09 1370	5500	6.350 0.2500	0.38 0.015	12.70 0.50	9.12 0.359	3.95 35	0.020 0.045
10.4 2330	15.2 3410	6.45 1450	2.88 647	6.89 1550	3900	9.525 0.3750	0.38 0.015	14.22 0.56	12.70 0.500	10.73 95	0.034 0.076
10.4 2330	15.2 3410	7.56 1700	4.80 1080	11.5 2590	3900	9.525 0.3750	0.38 0.015	14.22 0.56	12.70 0.500	10.73 95	0.044 0.097
13.3 2980	22.3 5010	8.94 2010	6.05 1360	14.5 3260	3000	11.113 0.4375	0.76 0.030	17.53 0.69	16.28 0.641	28.25 250	0.073 0.161
13.3 2980	22.3 5010	9.88 2220	8.67 1950	18.3 4120	3000	11.113 0.4375	0.76 0.030	17.53 0.69	16.28 0.641	28.25 250	0.089 0.197
23.3 5240	30.3 6810	16.1 3620	7.43 1670	17.8 40.10	2600	12.700 0.5000	0.76 0.030	20.57 0.81	19.43 0.765	39.54 350	0.137 0.301
23.3 5240	30.3 6810	17.7 3980	10.5 2350	25.1 5650	2600	12.700 0.5000	0.76 0.030	20.57 0.81	19.43 0.765	39.54 350	0.161 0.354
28.4 6380	40.8 9160	20.1 4520	10.8 2440	26.0 5850	2300	15.875 0.6250	0.76 0.030	23.88 0.94	22.63 0.891	73.44 650	0.239 0.528
28.4 6380	40.8 9160	21.5 4840	14.1 3170	33.8 7610	2300	15.875 0.6250	0.76 0.030	23.88 0.94	22.63 0.891	73.44 650	0.274 0.605
35.8 8040	56.9 12800	25.9 5830	17.7 3980	42.5 9560	1900	19.050 0.7500	1.02 0.040	26.92 1.06	26.59 1.047	141.23 1250	0.385 0.848
35.8 8040	56.9 12800	27.4 6150	22.0 4940	49.4 11100	1900	19.050 0.7500	1.02 0.040	26.92 1.06	26.59 1.047	141.23 1250	0.430 0.947

Continued on next page.

STUD-TYPE TRACK ROLLERS

CR, CRS SERIES – continued

INCH SERIES

- Screwdriver slot in head facilitates mounting.
- Non-separable, sealed unit with outer ring, full complement of needle rollers, stud seals, self-lubricating resin internal thrust washers and stud-fastened retaining washer.
- Seals help retain lubricant and exclude foreign matter (CRS Series).
- Re-lubrication via axially drilled hole through stud with cross-drilled holes in stud raceway and shank.
- Recessed axial hole accepts standard nominal inch drive-type grease lubrication fitting.
- Lubrication fitting plugs furnished to close off unused holes.
- Tolerance limits for outer diameters of stud, and outer ring refer to “single mean diameter.”
- A close fit between stud and hole required for mounting.
- Bore dimensions given below result in varying fit (0.025 mm (0.0010 in) tight to 0.013 mm (0.0005 in) loose).
- Retaining washer should be firmly backed up by flat housing shoulder (perpendicular to the stud axis).
- Shoulder diameter should be at least same size as minimum clamping diameter listed.
- May be mounted with two thin lock nuts, or nut and lock washer.

Outer Dia.	d ₁	D	C	B ₂	B ₃	G ₁	d ₂ and d ₄	d ₃	G	Track Roller Designation	
	+0.025 +0.0010 -0 -0.0000	+0 +0.000 -0.025 -0.001	+0 +0.000 -0.13 -0.005	(nom.)		Min.			UNF	Without Seals	With Seals and Internal Thrust Washers
in	mm in	mm in	mm in	mm in	mm in	mm in	mm in	mm in	in		
2	22.225 0.8750	50.80 2.000	31.75 1.250	50.80 2.000	12.70 0.500	25.40 1.000	4.77 0.188	4.77 0.188	7/8-14	CR-32	CRS-32
2 1/4	22.225 0.8750	57.15 2.250	31.75 1.250	50.80 2.000	12.70 0.500	25.40 1.000	4.77 0.188	4.77 0.188	7/8-14	CR-36	CRS-36
2 1/2	25.400 1.0000	63.50 2.500	38.10 1.500	57.15 2.250	14.27 0.562	28.58 1.125	4.77 0.188	4.77 0.188	1-14 ⁽¹⁾	CR-40	CRS-40
2 3/4	25.400 1.0000	69.85 2.750	38.10 1.500	57.15 2.250	14.27 0.562	28.58 1.125	4.77 0.188	4.77 0.188	1-14 ⁽¹⁾	CR-44	CRS-44
3	31.750 1.2500	76.20 3.000	44.45 1.750	63.50 2.500	15.88 0.625	31.75 1.250	6.35 0.250	6.35 0.250	1 1/4-12	CR-48	CRS-48
3 1/4	31.750 1.2500	82.55 3.250	44.45 1.750	63.50 2.500	15.88 0.625	31.75 1.250	6.35 0.250	6.35 0.250	1 1/4-12	CR-52	CRS-52
3 1/2	34.925 1.3750	88.90 3.500	50.80 2.000	69.85 2.750	17.48 0.688	34.93 1.375	6.35 0.250	6.35 0.250	1 3/8-12	CR-56	CRS-56
4	38.100 1.5000	101.60 4.000	57.15 2.250	88.90 3.500	19.05 0.750	38.10 1.500	6.35 0.250	6.35 0.250	1 1/2-12	CR-64	CRS-64

⁽¹⁾ UNS instead of UNF threads.

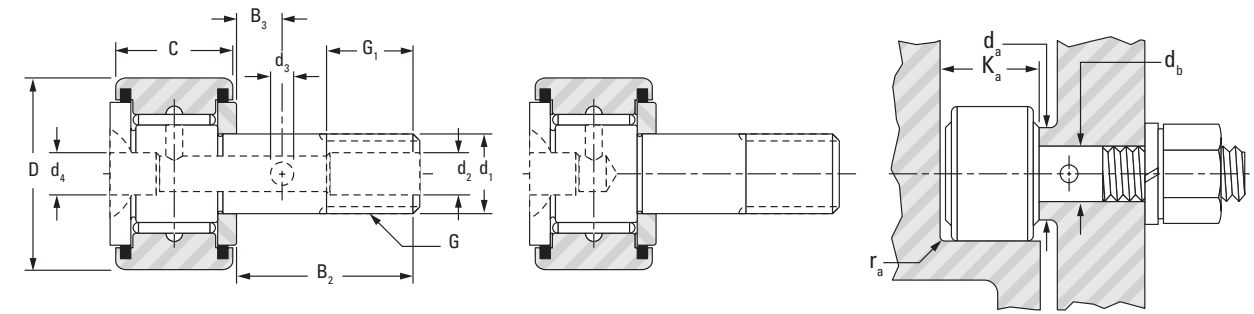

CR and CRS -12 to -64

CR and CRS -8 to -10-1

NOTE

Clamping torque is based on lubricated threads. If threads are dry, the torque values listed below may be doubled.

Load Ratings					Speed Rating Grease	Mounting Dimensions				Clamping Torque	Approx. Wt.
As a Bearing		As a Track Roller				db	ras max	Ka	da		
Dynamic	Static	Dynamic	Static	Static		Bore Dia. for Stud +0.013 +0.0005 -0 -0.0000	Max.	Min.	Min.		
C	Co	Cw	Fr perm	FOr perm	min ⁻¹	mm in	mm in	mm in	mm in	N-m lb-in	kg lbs
43.5 9770	76.1 17100	31.8 7160	26.0 5850	60.5 13600	1700	22.225 0.8750	1.27 0.050	33.78 1.33	30.56 1.203	169.48 1500	0.621 1.37
43.5 9770	76.1 17100	34.6 7770	36.7 8250	71.2 16000	1700	22.225 0.8750	1.27 0.050	33.78 1.33	30.56 1.203	169.48 1500	0.757 1.67
58.7 13200	118 26600	44.5 10000	51.6 11600	101 22700	1400	25.400 1.0000	2.29 0.090	40.13 1.58	34.93 1.375	254.22 2250	1.134 2.50
58.7 13200	118 26600	47.2 10600	66.7 15000	113 25500	1400	25.400 1.0000	2.29 0.090	40.13 1.58	34.93 1.375	254.22 2250	1.329 2.93
74.7 16800	179 40200	51.6 11600	64.0 14400	127 28600	990	31.750 1.2500	2.29 0.090	46.48 1.83	44.45 1.750	389.80 3450	1.905 4.20
74.7 16800	179 40200	54.7 12300	80.1 18000	143 32100	990	31.750 1.2500	2.29 0.090	46.48 1.83	44.45 1.750	389.80 3450	2.182 4.81
111 24900	227 51000	82.3 18500	89.8 20200	187 42000	950	34.925 1.3750	2.29 0.090	52.83 2.08	48.82 1.922	474.54 4200	2.912 6.42
138 31100	321 72200	99.2 22300	121 27200	245 55000	780	38.100 1.5000	2.29 0.090	59.18 2.33	57.94 2.281	564.93 5000	4.291 9.46

STUD-TYPE TRACK ROLLERS
CRSB SERIES
INCH SERIES

- Non-separable, sealed unit with outer ring, full complement of needle rollers, stud seals, self-lubricating resin internal thrust washers and stud-fastened retaining washer.
- Seals help retain lubricant and exclude foreign matter (CRS Series).
- Hexagonal wrench socket in stud head for mounting.
- Re-lubrication via axially drilled hole through stud with cross-drilled holes in stud raceway and shank.
- Recessed axial hole accepts standard nominal inch drive-type grease lubrication fitting.
- Lubrication fitting plugs furnished to close off unused holes.

- Tolerance limits for outer diameters of stud and outer ring refer to "single mean diameter."
- A close fit between stud and hole required for mounting.
- Bore dimensions given below result in varying fit (0.025 mm (0.0010 in) tight to 0.013 mm (0.0005 in) loose).
- Retaining washer should be firmly backed up by flat housing shoulder (perpendicular to the stud axis).
- Shoulder diameter should be at least same size as minimum clamping diameter listed.
- May be mounted with two thin lock nuts, or nut and lock washer.

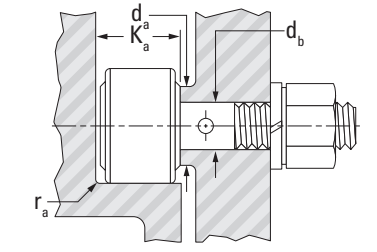
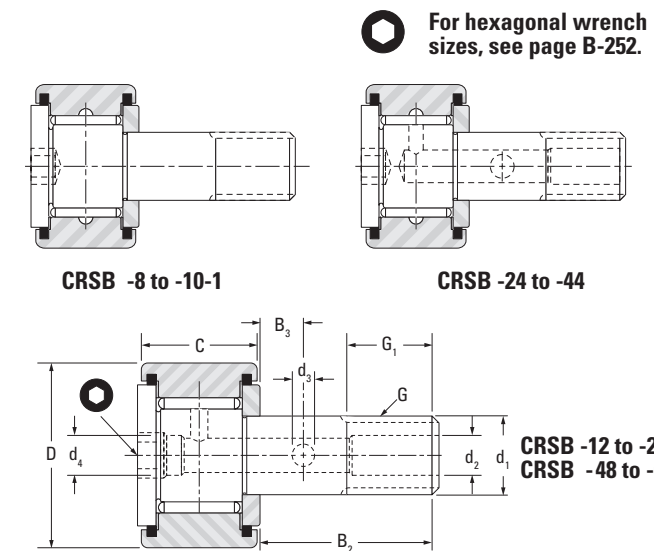

NOTE
Clamping torque is based on lubricated threads. If threads are dry, the torque values listed below may be doubled.

Outer Dia.	d ₁	D	C	B ₂	B ₃	G ₁	d ₄	d ₂	d ₃	G	Bearing Designation
	+0.025 +0.0010 -0 -0.0000	+0 +0.000 -0.025 -0.001	+0 +0.000 -0.13 -0.005	(nom.)		Min.				UNF	
in	mm in	mm in	mm in	mm in	mm in	mm in	mm in	mm in	mm in	mm in	
1/2	4.826 0.1900	12.70 0.500	8.74 0.344	12.70 0.500	—	6.35 0.250	—	—	—	10-32	CRSB-8
1/2	4.826 0.1900	12.70 0.500	9.53 0.375	15.88 0.625	—	6.35 0.250	—	—	—	10-32	CRSB-8-1
5/8	6.350 0.2500	15.88 0.625	10.31 0.406	15.88 0.625	—	7.92 0.312	—	—	—	1/4-28	CRSB-10
5/8	6.350 0.2500	15.88 0.625	11.13 0.438	19.05 0.750	—	7.92 0.312	—	—	—	1/4-28	CRSB-10-1
3/4	9.525 0.3750	19.05 0.750	12.70 0.500	22.23 0.875	6.35 0.250	9.53 0.375	—	4.78 0.188	2.39 0.094	3/8-24	CRSB-12
7/8	9.525 0.3750	22.23 0.875	12.70 0.500	22.23 0.875	6.35 0.250	9.53 0.375	—	4.78 0.188	2.39 0.094	3/8-24	CRSB-14
1	11.113 0.4375	25.40 1.000	15.88 0.625	25.40 1.000	6.35 0.250	12.70 0.500	—	4.78 0.188	2.39 0.094	7/16-20	CRSB-16
1 1/8	11.113 0.4375	28.58 1.125	15.88 0.625	25.40 1.000	6.35 0.250	12.70 0.500	—	4.78 0.188	2.39 0.094	7/16-20	CRSB-18
1 1/4	12.700 0.5000	31.75 1.250	19.05 0.750	31.75 1.250	7.92 0.312	15.88 0.625	—	4.78 0.188	2.39 0.094	1/2-20	CRSB-20
1 3/8	12.700 0.5000	34.93 1.375	19.05 0.750	31.75 1.250	7.92 0.312	15.88 0.625	—	4.78 0.188	2.39 0.094	1/2-20	CRSB-22
1 1/2	15.875 0.6250	38.10 1.500	22.23 0.875	38.10 1.500	9.53 0.375	19.05 0.750	—	4.78 0.188	2.39 0.094	5/8-18	CRSB-24
1 5/8	15.875 0.6250	41.28 1.625	22.23 0.875	38.10 1.500	9.53 0.375	19.05 0.750	—	4.78 0.188	2.39 0.094	5/8-18	CRSB-26
1 3/4	19.050 0.7500	44.45 1.750	25.40 1.000	44.45 1.750	11.13 0.438	22.23 0.875	—	4.78 0.188	2.39 0.094	3/4-16	CRSB-28

⁽¹⁾ UNS instead of UNF threads.
Furnished with lubrication hole in head end of stud and lubrication fitting installed below bottom of hex wrench socket.

Load Ratings					Speed Rating Grease	Mounting Dimensions				Clamping Torque	Approx. Wt.
As a Bearing		As a Track Roller				d _b	r _{as max}	K _a	d _a		
Dynamic	Static	Dynamic	Static				Bore Dia. for Stud +0.013 +0.0005 -0 -0.0000	Max.	Min.		
C	C ₀	C _w	F _{r perm}	F _{0r perm}	min ⁻¹	mm in	mm in	mm in	mm in	N-m lb-in	kg lbs
4.44 999	4.94 1110	3.01 677	1.04 233	2.49 560	7000	4.826 0.1900	0.25 0.010	10.4 0.41	7.54 0.297	1.69 15	0.010 0.022
4.98 1120	5.69 1280	3.38 759	1.21 272	2.90 652	7000	4.826 0.1900	0.25 0.010	11.2 0.44	7.54 0.297	1.69 15	0.010 0.023
6.05 1360	7.87 1770	4.37 982	2.26 508	5.43 1220	5500	6.350 0.2500	0.38 0.015	11.9 0.47	9.12 0.359	3.95 35	0.019 0.041
6.58 1480	8.76 1970	4.76 1070	2.53 569	6.09 1370	5500	6.350 0.2500	0.38 0.015	12.7 0.50	9.12 0.359	3.95 35	0.020 0.045
10.4 2330	15.2 3410	6.45 1450	2.88 647	6.89 1550	3900	9.525 0.3750	0.38 0.015	14.2 0.56	12.70 0.500	10.73 95	0.034 0.076
10.4 2330	15.2 3410	7.56 1700	4.80 1080	11.5 2590	3900	9.525 0.3750	0.38 0.015	17.5 0.69	12.70 0.500	10.73 95	0.044 0.097
13.3 2980	22.3 5010	8.94 2010	6.05 1360	14.5 3260	3000	11.113 0.4375	0.76 0.030	17.5 0.69	16.28 0.641	28.25 250	0.073 0.161
13.3 2980	22.3 5010	9.88 2220	8.67 1950	18.3 4120	3000	11.113 0.4375	0.76 0.030	20.6 0.81	16.28 0.641	28.25 250	0.089 0.197
23.3 5240	30.3 6810	16.1 3620	7.43 1670	17.8 4010	2600	12.700 0.5000	0.76 0.030	20.6 0.81	19.43 0.765	39.54 350	0.137 0.301
23.30 5240	30.3 6810	17.7 3980	10.5 2350	25.1 5650	2600	12.700 0.5000	0.76 0.030	23.9 0.94	19.03 0.765	39.54 350	0.161 0.354
28.4 6380	40.8 9160	20.1 4520	10.9 2440	26.0 5850	2300	15.875 0.6250	0.76 0.030	23.9 0.94	22.63 0.891	73.44 650	0.354 0.528
28.4 6380	40.8 9160	21.5 4840	14.1 3170	33.8 7610	2300	15.875 0.6250	0.76 0.030	26.9 1.06	22.63 0.891	73.44 650	0.274 0.605
35.8 8040	56.94 12800	25.9 5830	17.7 3980	42.5 9560	1900	19.050 0.7500	1.02 0.040	26.9 1.06	26.59 1.047	141.23 1250	0.385 0.848

Continued on next page.

STUD-TYPE TRACK ROLLERS

CRSB SERIES – continued

INCH SERIES

- Non-separable, sealed unit with outer ring, full complement of needle rollers, stud seals, self-lubricating resin internal thrust washers and stud-fastened retaining washer.
- Seals help retain lubricant and exclude foreign matter (CRS Series).
- Hexagonal wrench socket in stud head for mounting.
- Re-lubrication via axially drilled hole through stud with cross-drilled holes in stud raceway and shank.
- Recessed axial hole accepts standard nominal inch drive-type grease lubrication fitting.
- Lubrication fitting plugs furnished to close off unused holes.

- Tolerance limits for outer diameters of stud and outer ring refer to “single mean diameter.”
- A close fit between stud and hole required for mounting.
- Bore dimensions given below result in varying fit (0.025 mm (0.0010 in) tight to 0.013 mm (0.0005 in) loose).
- Retaining washer should be firmly backed up by flat housing shoulder (perpendicular to the stud axis).
- Shoulder diameter should be at least same size as minimum clamping diameter listed.
- May be mounted with two thin lock nuts, or nut and lock washer.

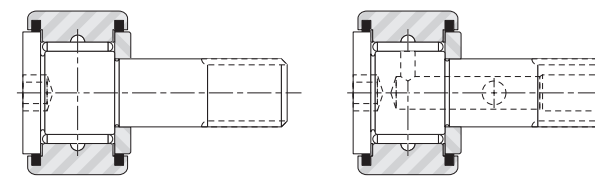

CRSB -8 to -10-1

CRSB -24 to -44

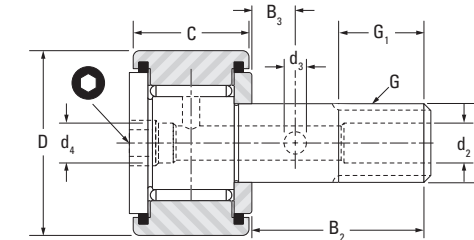

CRSB -12 to -22
CRSB -48 to -64

For hexagonal wrench sizes, see page B-252.

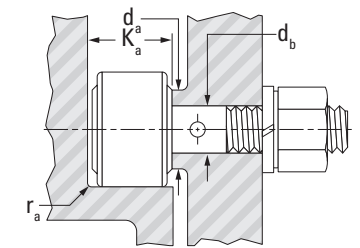

NOTE
Clamping torque is based on lubricated threads. If threads are dry, the torque values listed below may be doubled.

Outer Dia.	d ₁	D	C	B ₂	B ₃	G ₁	d ₄	d ₂	d ₃	G	Bearing Designation
	+0.025 +0.0010 -0 -0.0000	+0 +0.000 -0.025 -0.001	+0 +0.000 -0.13 -0.005	(nom.)		Min.				UNF	
in	mm in	mm in	mm in	mm in	mm in	mm in	mm in	mm in	mm in	mm in	
1 7/8	19.050 0.7500	47.63 1.875	25.40 1.000	44.45 1.750	11.13 0.438	22.23 0.875	—	4.78 0.188	2.39 0.094	3/4-16	CRSB-30
2	22.225 0.8750	50.80 2.000	31.75 1.250	50.80 2.000	12.70 0.500	25.40 1.000	—	4.78 0.188	3.18 0.125	7/8-14	CRSB-32
2 1/4	22.225 0.8750	57.15 2.250	31.75 1.250	50.80 2.000	12.70 0.500	25.40 1.000	—	4.78 0.188	3.18 0.125	7/8-14	CRSB-36
2 1/2	25.400 1.0000	63.50 2.500	38.10 1.500	57.15 2.250	14.27 0.562	28.58 1.125	—	4.78 0.188	3.18 0.125	1-14 ⁽¹⁾	CRSB-40
2 3/4	25.400 1.0000	69.85 2.750	38.10 1.500	57.15 2.250	14.27 0.562	28.58 1.125	—	4.78 0.188	3.18 0.125	1-14 ⁽¹⁾	CRSB-44
3	31.750 1.2500	76.20 3.000	44.45 1.750	63.50 2.500	15.88 0.625	31.75 1.250	6.35 0.250	6.35 0.250	3.18 0.125	1 1/4-12	CRSB-48
3 1/4	31.750 1.2500	82.55 3.250	44.45 1.750	63.50 2.500	15.88 0.625	31.75 1.250	6.35 0.250	6.35 0.250	3.18 0.125	1 1/4-12	CRSB-52
3 1/2	34.925 1.3750	88.90 3.500	50.80 2.000	69.85 2.750	17.48 0.688	34.93 1.375	6.35 0.250	6.35 0.250	3.18 0.125	1 3/8-12	CRSB-56
4	38.100 1.5000	101.60 4.000	57.15 2.250	88.90 3.500	19.05 0.750	38.10 1.500	6.35 0.250	6.35 0.250	3.18 0.125	1 1/2-12	CRSB-64
5	50.80 2.000	127.0 5.000	69.85 2.750	128.57 5.062	22.352 0.88	65.075 2.562	1/4 NPT	1/4 NPT	4.77 0.188	2-12	CRSB-80
6	63.50 2.500	152.4 6.000	82.55 3.250	152.4 6.000	25.40 1.00	76.2 3.000	1/4 NPT	1/4 NPT	4.77 0.188	2 1/2-12	CRSB-96

⁽¹⁾ UNS instead of UNF threads.
Furnished with lubrication hole in head end of stud and lubrication fitting installed below bottom of hex wrench socket.

Load Ratings					Speed Rating Grease	Mounting Dimensions				Clamping Torque	Approx. Wt.
As a Bearing		As a Track Roller				d _b	r _{as max}	K _a	d _a		
Dynamic	Static	Dynamic		Static		Bore Dia. for Stud	Max.	Min.	Min.		
C	C ₀	C _w	F _{r perm}	F _{0r perm}		+0.013 +0.0005 -0 -0.0000					
in	mm in	mm in	mm in	mm in	mm in	mm in	mm in	mm in	N-m lb-in	kg lbs	
35.8 8040	56.94 12800	27.4 6150	22.0 4940	49.4 11100	1900	19.050 0.7500	1.02 0.040	33.8 1.33	26.59 1.047	84.74 750	0.430 0.947
43.5 9770	76.06 17100	31.8 7160	26.0 5850	60.5 13600	1700	22.225 0.8750	1.27 0.050	33.8 1.33	30.56 1.203	101.69 900	0.621 1.370
43.5 9770	76.06 17100	34.6 7770	36.7 8250	71.2 16000	1700	22.225 0.8750	1.27 0.050	40.1 1.58	30.56 1.203	101.69 900	0.757 1.670
58.7 13200	118.32 26600	44.5 10000	51.6 11600	101 22700	1400	25.400 1.0000	2.29 0.090	40.1 1.58	34.93 1.375	152.53 1350	1.134 2.500
58.7 13200	118.32 26600	47.2 10600	66.7 15000	113 25500	1400	25.400 1.0000	2.29 0.090	44.5 1.75	34.93 1.375	152.53 1350	1.329 2.930
74.7 16800	178.82 40200	51.6 11600	64.0 14400	127 28600	990	31.750 1.2500	2.29 0.090	46.5 1.83	44.45 1.750	231.62 2050	1.905 4.200
74.7 16800	178.82 40200	54.7 12300	80.1 18000	143 32100	990	31.750 1.2500	2.29 0.090	46.5 1.83	44.45 1.750	231.62 2050	2.182 4.810
110.8 24900	226.86 51000	82.3 18500	89.8 20200	187 42000	950	34.925 1.3750	2.29 0.090	52.8 2.08	48.82 1.922	282.46 2500	2.912 6.420
138.3 31100	321.16 72200	99.2 22300	121 27200	245 55000	780	38.100 1.5000	2.29 0.090	59.2 2.33	57.94 2.281	338.95 3000	4.291 9.460
211.0 47300	485.0 109000	152.0 34200	193.0 43400	385.0 86600	620	50.800 2.000	3.18 0.125	73.15 2.88	73.03 2.875	564.9 5000	8.89 19.60
285.0 64100	576.0 130000	209.0 47100	238.0 53600	473.0 106000	520	63.500 2.500	3.18 0.125	85.85 3.38	85.73 3.375	564.9 5000	14.86 32.76

YOKE-TYPE TRACK ROLLERS
YCR, YCRS SERIES

INCH SERIES

- Non-separable unit with outer ring, a full complement of needle rollers, inner ring, self-lubricating resin internal thrust washers, and two retaining washers securely fastened to the inner ring.
- Seals in counterbores of outer ring seal against the retaining washers; retain lubricant and exclude foreign matter (YCRS Series).
- Dimensions shown are for unplated finished unit.

- Tolerance limits for outer diameters of stud and outer ring refer to "single mean diameter."
- The machine element with the holes in which the mounting bolt is supported must be sufficiently rigid to resist local crushing under the applied load and to resist bending which can cause uneven loading of the rollers.
- When the applied loads are high, the tight transition fit should be used in conjunction with a high strength shaft or bolt. When loads are moderate, the loose transition fit may be used with a high strength shaft or bolt. For light loads, the loose transition fit may be used with an unhardened shaft or bolt.

Outer Dia.	D		d		B	C	b	Track Roller Designation	
	+0 +0.000 -0.03 -0.001	Max.	Min.	+0.130 +0.0050 -0.250 -0.0100	+0 +0.000 -0.13 -0.005	(nom.)	Without Seals	With Seals and Internal Thrust Washers	
in	mm in	mm in	mm in	mm in	mm in	mm in			
3/4	19.05 0.75	6.355 0.2502	6.34 0.2496	14.288 0.5625	12.7 0.5	2.95 0.116	YCR-12	YCRS-12	
7/8	22.23 0.875	6.355 0.2502	6.34 0.2496	14.288 0.5625	12.7 0.5	2.95 0.116	YCR-14	YCRS-14	
1	25.4 1	7.943 0.3127	7.927 0.3121	17.463 0.6875	15.88 0.625	3.18 0.125	YCR-16	YCRS-16	
1 1/8	28.58 1.125	7.943 0.3127	7.927 0.3121	17.463 0.6875	15.88 0.625	3.18 0.125	YCR-18	YCRS-18	
1 1/4	31.75 1.25	9.53 0.3752	9.515 0.3746	20.638 0.8125	19.05 0.75	3.18 0.125	YCR-20	YCRS-20	
1 3/8	34.93 1.375	9.53 0.3752	9.515 0.3746	20.638 0.8125	19.05 0.75	3.18 0.125	YCR-22	YCRS-22	
1 1/2	38.1 1.5	11.118 0.4377	11.102 0.4371	23.813 0.9375	22.23 0.875	3.18 0.125	YCR-24	YCRS-24	
1 5/8	41.28 1.625	11.118 0.4377	11.102 0.4371	23.813 0.9375	22.23 0.875	3.18 0.125	YCR-26	YCRS-26	
1 3/4	44.45 1.75	12.705 0.5002	12.69 0.4996	26.988 1.0625	25.4 1	3.18 0.125	YCR-28	YCRS-28	
1 7/8	47.63 1.875	12.705 0.5002	12.69 0.4996	26.988 1.0625	25.4 1	3.18 0.125	YCR-30	YCRS-30	
2	50.8 2	15.88 0.6252	15.865 0.6246	33.338 1.3125	31.75 1.25	3.18 0.125	YCR-32	YCRS-32	
2 1/4	57.15 2.25	15.88 0.6252	15.865 0.6246	33.338 1.3125	31.75 1.25	3.18 0.125	YCR-36	YCRS-36	
2 1/2	63.5 2.5	19.055 0.7502	19.04 0.7496	39.688 1.5625	38.1 1.5	3.68 0.145	YCR-40	YCRS-40	
2 3/4	69.85 2.75	19.055 0.7502	19.04 0.7496	39.688 1.5625	38.1 1.5	3.68 0.145	YCR-44	YCRS-44	
3	76.2 3	25.403 1.0001	25.387 0.9995	46.038 1.8125	44.45 1.75	3.68 0.145	YCR-48	YCRS-48	
3 1/4	82.55 3.25	25.403 1.0001	25.387 0.9995	46.038 1.8125	44.45 1.75	3.68 0.145	YCR-52	YCRS-52	
3 1/2	88.9 3.5	28.578 1.1251	28.562 1.1245	52.388 2.0625	50.8 2	3.68 0.145	YCR-56	YCRS-56	
4	101.6 4	31.753 1.2501	31.737 1.2495	58.738 2.3125	57.15 2.25	3.68 0.145	YCR-64	YCRS-64	
5	127.0 5.00	44.453 1.7501	44.437 1.7495	73.025 2.875	69.85 2.750	8.64 0.341	YCR-80	YCRS-80	
6	152.4 6.00	57.153 2.2501	57.137 2.2495	85.725 3.375	82.55 3.250	8.48 0.334	YCR-96	YCRS-96	

- The unit should be clamped endwise between parallel faces perpendicular to the axis to prevent the retaining washers from coming off under load. If the unit cannot be clamped, a close axial fit in the yoke is required.

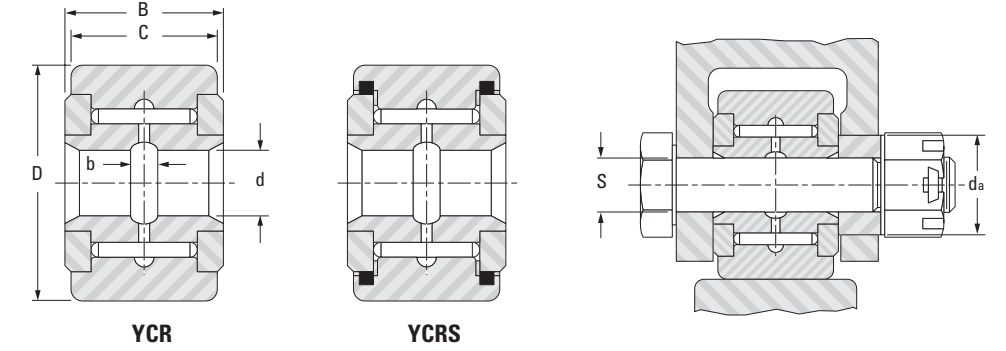

Load Ratings					Speed Rating Grease	Mounting Dimensions				da	Approx. Wt.
As a Bearing		As a Track Roller				Shaft Bolt Diameter (S)					
Dynamic	Static	Dynamic		Loose Fit (f7)		Tight Fit (h6)					
C	Co	Cw	Fr perm	F0r perm		Max.	Min.	Max.	Min.		
	kN lbf		kN lbf		mm in	mm in	mm in	mm in	mm in	kg lbs	
10.4 2330	15.2 3410	6.45 1450	2.88 647	6.89 1550	3900	6.342 0.2497	6.332 0.2493	6.363 0.2505	6.353 0.2501	12.700 0.500	0.027 0.06
10.4 2330	15.2 3410	7.56 1700	4.8 1080	11.5 2590	3900	6.342 0.2497	6.332 0.2493	6.363 0.2505	6.353 0.2501	12.700 0.500	0.036 0.08
13.3 2980	22.3 5010	8.94 2010	6.05 1360	14.5 3260	3000	7.93 0.3122	7.92 0.3118	7.95 0.313	7.94 0.3126	16.272 0.641	0.068 0.15
13.3 2980	22.3 5010	9.88 2220	8.67 1950	18.3 4120	3000	7.93 0.3122	7.92 0.3118	7.95 0.313	7.94 0.3126	16.272 0.641	0.077 0.17
23.3 5240	30.3 6810	16.1 3620	7.43 1670	17.8 4010	2600	9.517 0.3747	9.507 0.3743	9.538 0.3755	9.528 0.3751	19.447 0.766	0.109 0.24
23.3 5240	30.3 6810	17.7 3980	10.5 2350	25.1 5650	2600	9.517 0.3747	9.507 0.3743	9.538 0.3755	9.528 0.3751	19.447 0.766	0.136 0.3
28.4 6380	40.7 9160	20.1 4520	10.8 2440	26 5850	2300	11.105 0.4372	11.095 0.4368	11.125 0.438	11.115 0.4376	22.622 0.891	0.186 0.41
28.4 6380	40.7 9160	21.5 4840	14.1 3170	33.8 7610	2300	11.105 0.4372	11.095 0.4368	11.125 0.438	11.115 0.4376	22.622 0.891	0.227 0.5
35.8 8040	56.9 12800	25.9 5830	17.7 3980	42.5 9560	1900	12.692 0.4997	12.682 0.4993	12.718 0.5007	12.708 0.5003	26.591 1.047	0.29 0.64
35.8 8040	56.9 12800	27.4 6150	22 4940	49.4 11100	1900	12.692 0.4997	12.682 0.4993	12.718 0.5007	12.708 0.5003	26.591 1.047	0.363 0.8
43.5 9770	76.1 17100	31.8 7160	26 5850	60.5 13600	1700	15.867 0.6247	15.857 0.6243	15.893 0.6257	15.883 0.6253	30.559 1.203	0.476 1.05
43.5 9770	76.1 17100	34.6 7770	36.7 8250	71.2 16000	1700	15.867 0.6247	15.857 0.6243	15.893 0.6257	15.883 0.6253	30.559 1.203	0.599 1.32
58.7 13200	118 26600	44.5 10000	51.6 11600	100 22700	1400	19.042 0.7497	19.032 0.7493	19.068 0.7507	19.058 0.7503	33.338 1.313	0.816 1.8
58.7 13200	118 26600	47.2 10600	66.7 15000	113 25500	1400	19.042 0.7497	19.032 0.7493	19.068 0.7507	19.058 0.7503	33.338 1.313	1.021 2.25
74.7 16800	179 40200	51.6 11600	64 14400	127 28600	990	25.39 0.9996	25.377 0.9991	25.42 1.0008	25.408 1.0003	44.450 1.750	1.406 3.1
74.7 16800	179 40200	54.7 12300	80.1 18000	143 32100	990	25.39 0.9996	25.377 0.9991	25.42 1.0008	25.408 1.0003	44.450 1.750	1.642 3.62
111 24900	227 51000	82.3 18500	89.8 20200	187 42000	950	28.565 1.1246	28.552 1.1241	28.595 1.1258	28.583 1.1253	48.816 1.922	2.245 4.95
138 31100	321 72200	99.2 22300	121 27200	245 55000	780	31.74 1.2496	31.727 1.2491	31.77 1.2508	31.758 1.2503	57.944 2.281	3.198 7.05
211 47300	485 109000	152 34200	193 43400	385 86600	620	44.440 1.7496	44.427 1.7491	44.470 1.7508	44.458 1.7503	73.025 2.875	6.505 14.34
285 64100	576 130000	209 47100	238 53600	473 106000	520	57.140 2.2496	57.127 2.2491	57.170 2.2508	57.158 2.2503	85.725 3.375	9.144 20.16

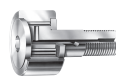

NOTES

THRUST BEARINGS, ASSEMBLIES, WASHERS

Overview: Thrust needle roller and cage assemblies are complements of small diameter needle rollers, arranged in a spoke-like configuration. Needle rollers are equally spaced by means of a cage, its web section separates the rollers and provides guidance to keep them tracking in an orbital path. The purpose of these assemblies is to transmit a thrust load between two relatively rotating objects while greatly reducing friction.

Thrust needle roller and cage assemblies also can be unitized with lipped washers to serve as raceway surfaces for the needle rollers. Washers can be supplied separately or can be mechanically unitized to the thrust needle roller and cage assemblies for ease of handling.

- **Sizes:** 5 mm – 240 mm (0.1969 in – 9.4488 in).
- **Markets:** Automotive automatic and manual transmissions, automotive accessories (compressors, steering gears, etc.) agricultural and construction equipment.
- **Features:** One-way fool-proof assembly features, anti-rotation locking features and lubrication flow enhancements.
- **Benefits:** High-speed performance and application flexibility.



Needle Roller Thrust Bearings – Metric Nominal Dimensions

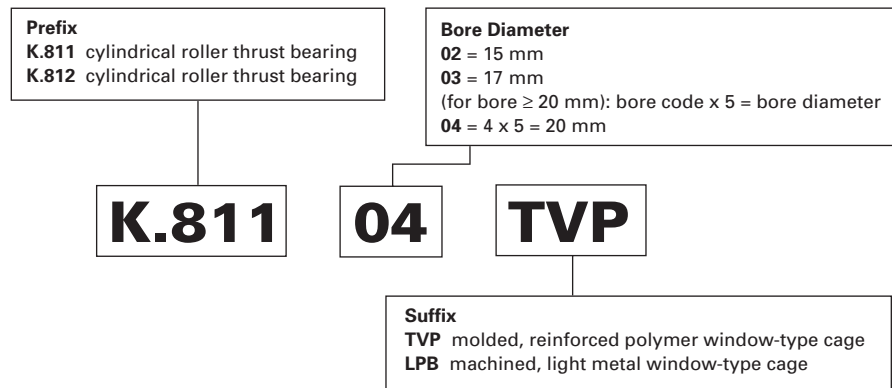
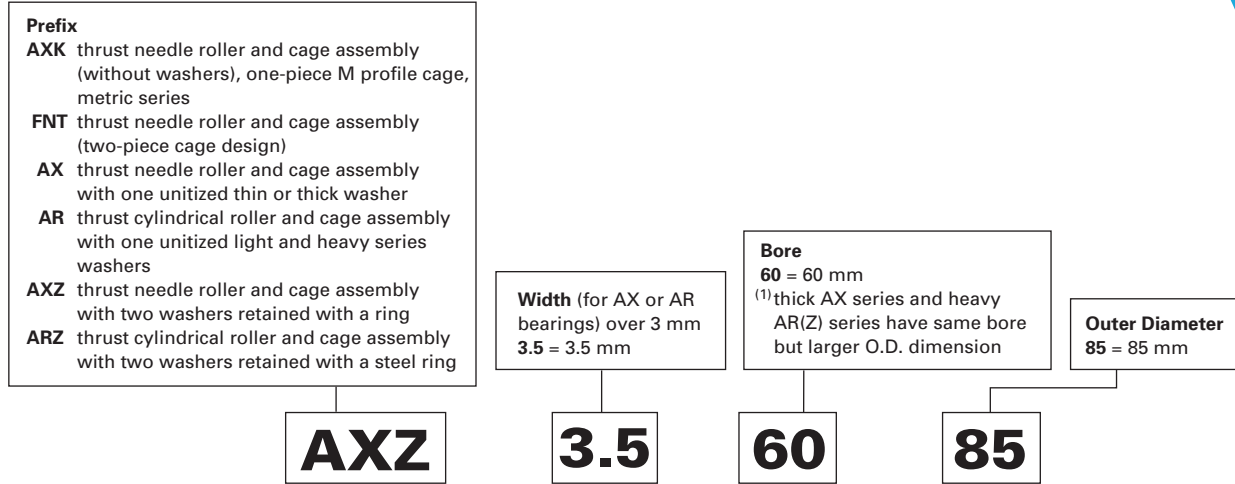

Thrust Washers – Metric Nominal Dimensions

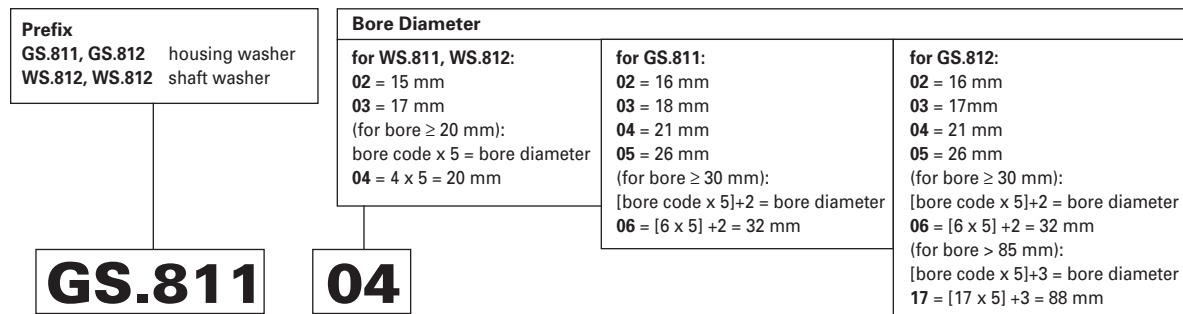
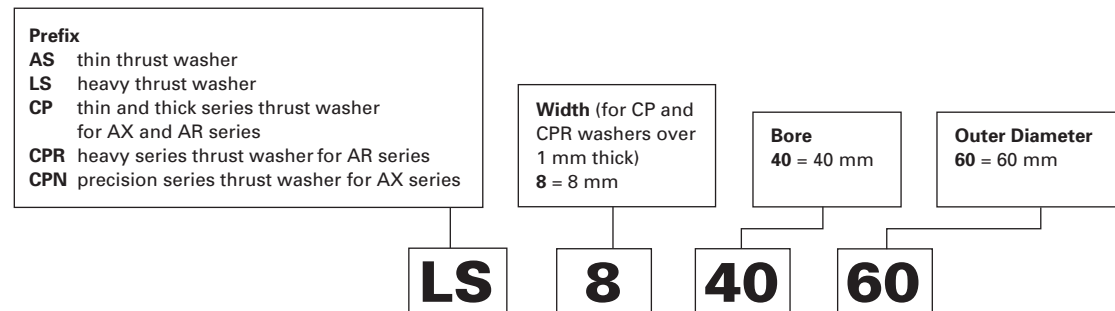

Thrust Bearings – Inch Nominal Dimensions

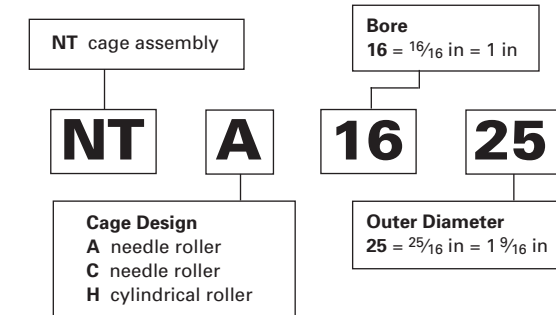

Thrust Washers – Inch Nominal Dimensions

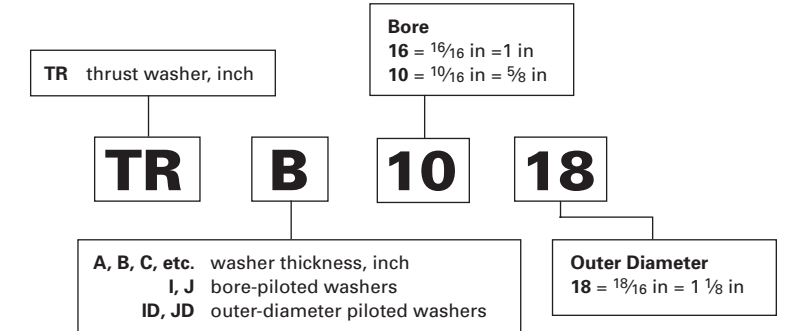



Thrust Bearings, Assemblies and Washers

THRUST NEEDLE ROLLER AND CAGE ASSEMBLIES AND THRUST WASHERS – METRIC SERIES	Page
Introduction	B-272
Thrust Needle Roller and Cage Assemblies, Thrust Washers	B-278
Unitized Thrust Bearing Type FNTKF	B-282
Unitized Thrust Bearing Type FNTK	B-283
Unitized Thrust Bearing Type FNTF	B-284
Unitized Thrust Bearings Type AX	B-286
 CYLINDRICAL ROLLER THRUST BEARINGS AND THEIR COMPONENTS – METRIC SERIES	
Introduction	B-294
Thrust Cylindrical Roller and Cage Assemblies, Thrust Washers	B-298
Needle or Roller Thrust Bearings	B-302
Unitized Roller Thrust Bearing Assemblies	B-304
 THRUST ASSEMBLIES AND THRUST BEARINGS – INCH SERIES	
Introduction	B-308
Thrust Needle Roller and Cage Assemblies, Thrust Washers	B-312
Thrust Cylindrical Roller and Cage Assemblies	B-322
Cylindrical Roller Thrust Bearings	B-324

THRUST NEEDLE ROLLER AND CAGE ASSEMBLIES AND THRUST WASHERS

METRIC SERIES

Thrust needle roller and cage assemblies are available in a variety of sizes. They all have very small cross sections. This catalog includes the most popular, standardized designs.

REFERENCE STANDARDS ARE:

- **ISO 3031** – rolling bearings – thrust needle roller and cage assemblies, thrust washers – dimensions and tolerances.
- **DIN 5405 Part 2** – rolling bearings – needle roller bearings – thrust needle roller and cage assemblies.
- **DIN 5405 Part 3** – rolling bearings – needle roller bearings – thrust washers.
- **ANSI/ABMA Std. 21.1-1988** – thrust needle roller and cage assemblies and thrust washers – metric design.

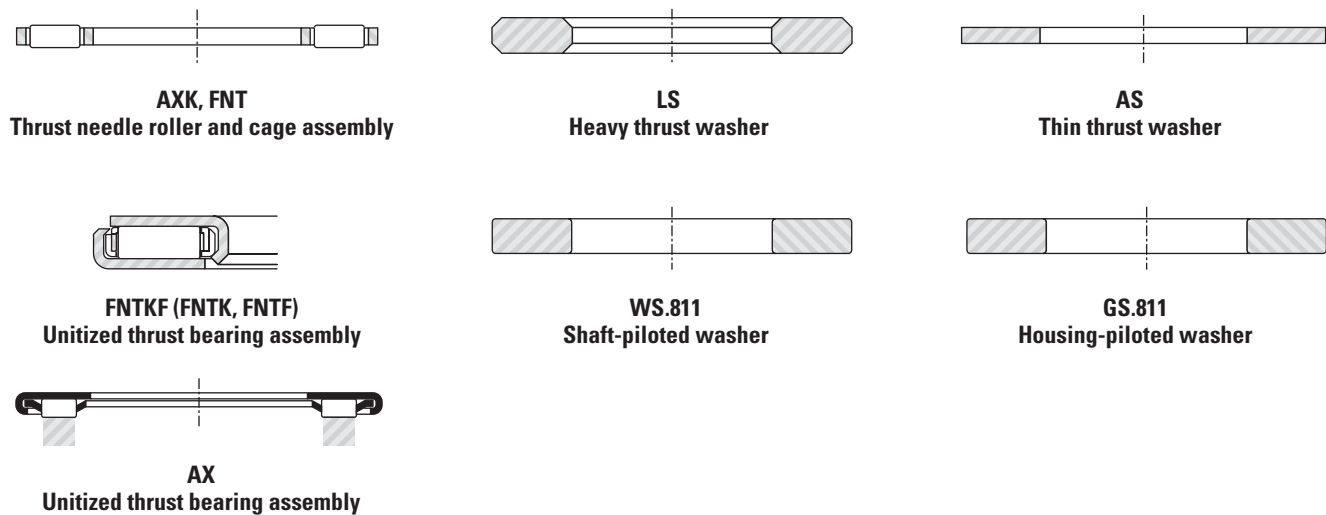

Fig. B-71. Types of metric series thrust needle roller and cage assemblies and thrust washers

CONSTRUCTION

THRUST NEEDLE ROLLER AND CAGE ASSEMBLIES

The thrust needle roller and cage assembly (FNT series) has a two-piece steel cage and through-hardened needle rollers that are precision finished to close tolerances for optimum load distribution. The cage is comprised of two mating pieces that are securely fastened together.

AXK series thrust needle roller and cage assembly, which can be used interchangeably with the FNT assembly, has a one-piece cage. The cage is similar in design to the successful profiled radial steel cages.

These cage assemblies have a very thin section and when they must run directly against the backup surface raceways, their section may be 2.000 to 5.000 mm (0.0787 to 0.1969 in) – equivalent to the diameter of the needle rollers used.

When the backup surfaces cannot be hardened and ground, hardened washers of different thicknesses are available.

UNITIZED THRUST BEARING ASSEMBLIES

Thrust bearing assemblies of the FNTK, FNTF and FNTKF series have been specially designed for use in applications where a unitized assembly allows for easy installation and eliminates the need for heat treatment and precision finishing of one or both thrust bearing backup surfaces.

Each FNTK, FNTF or FNTKF assembly consists of a FNT thrust needle roller and cage assembly – with one or two special-lipped washers that snap over the cage to produce a unitized thrust bearing assembly. The FNTK and FNTF assembly has one such washer. The FNTKF assembly has a washer on each side of the bearing.

The backup surfaces for these unitized thrust bearing assemblies should meet the limits of permissible out-of-squareness and coning or dishing, as shown in Fig. B-72 on page B-276. Oil is the preferred lubricant for these assemblies. However they also are available pre-greased for applications that do not allow for oil lubrication.

The rolling elements of the AX series thrust bearings are retained

and guided in radial pockets within the cage. The cage is retained in relation to the thrust washer by means of a retaining cap. The design of a one-piece steel cage employs a special curvature that guides the rolling elements, by their ends, along their centerlines.

In addition, this special curvature gives the steel cage great rigidity, while providing maximum lubricant space. This unitized assembly of components facilitates installation and provides a high-axial-load capacity, while occupying only minimal space. Note that the AX series is not interchangeable with the AXK series or FNT series thrust needle roller and cage assemblies.

THRUST WASHERS

Ideally, a thrust washer should be stationary with respect to, and piloted by, its supporting or backing member – whether or not this is an integral part of the shaft or housing. There should be no rubbing action between the thrust washer and any other machine member. Some thrust washers are designed for bore piloting and others may be piloted by their outer diameter.

THIN THRUST WASHERS (AS)

The metric series thin thrust washers are made of hardened spring steel. They may be out-of-flat due to heat treatment, but will flatten under load. Thin washers are used when the supporting or backing members cannot be adequately prepared as raceways for the needle rollers. These washers are only 1.000 mm (0.0394 in) thick, and provide a very compact and cost-effective bearing arrangement. Although they are usually guided on the shaft, they may be housing-guided, when required by the application.

HEAVY THRUST WASHERS (LS)

These metric series thrust washers are made of bearing quality steel, hardened and precision-ground on the flat raceway surfaces. Their bores and outer diameters are not ground, but provide satisfactory surfaces for shaft-piloting or housing-piloting arrangements.

SHAFT-PILOTED WASHERS (WS.811) AND HOUSING-PILOTED WASHERS (GS.811)

These shaft-piloted and housing-piloted metric series thrust washers are primarily for use with metric series cylindrical roller thrust bearings of series 811. They are made of bearing-quality steel with hardened and precision-ground, lapped-flat raceway surfaces. The tolerances of the thrust bearing bore and outer diameter shown, in the engineering section of this catalog, apply to shaft- and housing-piloted washers.

THIN/THICK (CP) AND HEAVY (CPR) THRUST WASHERS

The washer incorporated in the AX series thrust bearing is made from hardened bearing steel. It forms one of the raceways for the rolling elements. The opposing raceway is generally provided by a separate thrust washer of similar design supplied by JTEKT. When the AX series thrust bearing is piloted by the revolving part, the thrust washer must be piloted by the stationary part and vice versa. If the revolving part and the stationary part are noticeably eccentric to each other, the thrust bearing with integral washer must, without exception, be piloted by the revolving part.

The second raceway for the rolling elements also may be formed by the face of a shoulder or an inserted washer, provided these have the correct hardness and geometric dimensions.

DIMENSIONAL ACCURACY

TOLERANCES FOR THRUST NEEDLE ROLLER AND CAGE ASSEMBLIES

Pages B-278 to B-281 list the nominal outer diameter, bore diameter and needle roller diameter for the FNT and AXK series of thrust needle roller and cage assemblies and also the nominal outer diameter and bore diameter of the series AS, LS, WS and GS thrust washers. Thickness tolerances for the AS and LS thrust washers also are included.

Tolerances for the outer and bore diameters of series FNT and AXK thrust needle roller and cage assemblies are given in Table B-44 and Table B-45 on page B-274.

Table B-44. Tolerances for outer diameter (D_c) and bore diameter (D_{c1}) of series FNT thrust needle roller and cage assemblies

D_c		Deviations of max. outside diameter (c12)		D_{c1}		Deviations of min. bore diameter (E11)	
>	≤	Max.	Min.	>	≤	Max.	Min.
mm in	mm in	mm in	mm in	mm in	mm in	mm in	mm in
18.000 0.7087	30.000 1.1811	-0.110 -0.0043	-0.320 -0.0126	3.000 0.1181	6.000 0.2362	+0.095 +0.0037	+0.020 +0.0008
30.000 1.1811	40.000 1.5748	-0.120 -0.0047	-0.370 -0.0146	6.000 0.2362	10.000 0.3937	+0.115 +0.0045	+0.025 +0.0010
40.000 1.5748	50.000 1.9685	-0.130 -0.0051	-0.380 -0.0150	10.000 0.3937	18.000 0.7087	+0.142 +0.0056	+0.032 +0.0013
50.000 1.9685	65.000 2.5591	-0.140 -0.0055	-0.440 -0.0173	18.000 0.7087	30.000 1.1811	+0.170 +0.0067	+0.040 +0.0016
65.000 2.5591	80.000 3.1496	-0.150 -0.0059	-0.450 -0.0177	30.000 1.1811	50.000 1.9685	+0.210 +0.0083	+0.050 +0.0020
80.000 3.1496	100.000 3.9370	-0.170 -0.0067	-0.520 -0.0205	50.000 1.9685	80.000 3.1496	+0.250 +0.0098	+0.060 +0.0024
100.000 3.9370	120.000 4.7244	-0.180 -0.0071	-0.530 -0.0209	80.000 3.1496	120.000 4.7244	+0.292 +0.0115	+0.072 +0.0028
120.000 4.7244	140.000 5.5118	-0.200 -0.0079	-0.600 -0.0236	120.000 4.7244	180.000 7.0866	+0.335 +0.0132	+0.085 +0.0033
140.000 5.5118	160.000 6.2992	-0.210 -0.0083	-0.610 -0.0240				
160.000 6.2992	180.000 7.0866	-0.230 -0.0091	-0.630 -0.0248				
180.000 7.0866	200.000 7.8740	-0.240 -0.0094	-0.700 -0.0276				

MOUNTING TOLERANCES

THRUST NEEDLE ROLLER AND CAGE ASSEMBLIES – METRIC SERIES

On FNT and AXK series thrust needle roller and cage assemblies, the cage bore has a closer tolerance than the outer diameter. Therefore bore piloting is preferred for these assemblies. To reduce wear, it is suggested that the piloting surface for the cage be hardened to an equivalent of at least 55 HRC. Where design requirements prevent bore piloting, the FNT or AXK series thrust needle roller and cage assemblies may be piloted on the outer diameters. For such cases, suitable O.D. piloting dimensions should be determined. Mounting tolerances are given in Table B-49 on page B-275.

THRUST WASHERS

The mounting tolerances for series AS, LS, WS and GS thrust washers for use with thrust needle roller and cage assemblies are given in Table B-49 on page B-275.

To reduce the wear in the FNT and AXK series thrust assemblies, the piloting surface for the thrust washers should also be hardened to an equivalent of at least 55 HRC.

BACKUP SURFACES

In some applications, it is desirable to use the backup surfaces as raceways for the needle rollers of the thrust needle roller and cage assemblies. In such designs, these surfaces should be parallel and must be hardened to at least 58 HRC. If this hardness cannot be achieved and thrust washers cannot be used, the load ratings must be reduced as explained in the engineering section of this catalog.

Thrust raceway surfaces must be ground to a surface finish of 0.2 μm Ra (8 μin Ra). When this requirement cannot be met, thrust washers must be used.

The raceways against which the needle rollers operate, or the surface against which the thrust washers bear, must be square with the axis of the shaft. Equally important, the raceway or surface backing of the thrust washer must not be dished or coned. The permissible limits of out-of-squareness and dishing or coning are shown in the figures below.

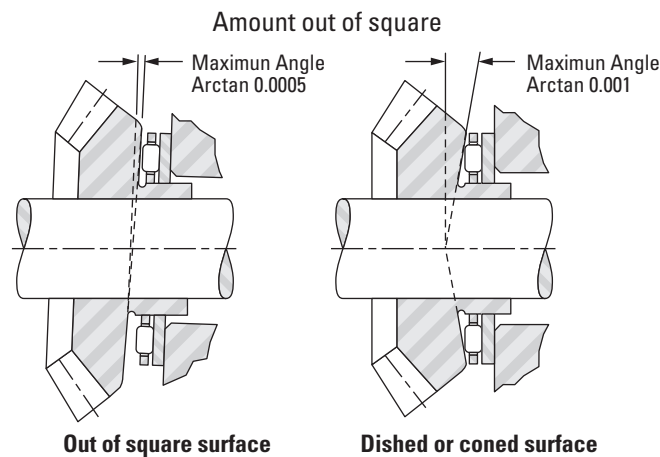

Fig. B-72. Permissible limits

Raceway contact dimensions E_a and E_b are given in the bearing tables. For the thin series AS thrust washers, full backup between the dimensions E_a and E_b should be provided.

Thin series needle thrust bearings and thin thrust washers must be supported on a flat, rigid and continuous face throughout the area of circulation of the needles bounded by dimensions E_b and E_a .

Thick series needle thrust bearings and thick thrust washers can be supported on a more restricted or discontinuous shoulder – provided that the deflection of the washer under load does not impede the smooth operation of the thrust bearing or the required axial run-out.

When an application does not involve the use of a thrust washer, the surface forming the second raceway must:

- Extend at least across the whole area of circulation of the rolling elements between dimensions E_b and E_a .
- Possess a suitable surface finish 0.2 μm Ra (8 μin Ra) and sufficient hardness in relation to the load to be supported. A minimum hardness of 58 HRC, enables thrust bearings to carry their full load capacity. Lower hardness values reduce the capacities shown in the tables of dimensions (see tabulated sizes).

TOLERANCES FOR PILOTING SURFACES (AX SERIES)

- Piloting on the shaft: h10 on dimensions D_{c1} for thrust bearings or dimension d for thrust washers.
- Piloting in the housing: H10 on dimensions D for thrust bearings or dimension d_1 for thrust washers.

LOAD RATINGS

MINIMUM AXIAL LOAD

Slippage can occur if the applied axial load is too light and the operating speed of the thrust needle roller and cage assembly is high – particularly if accompanied by inadequate lubrication. For satisfactory operation, a certain minimum load must be applied to a thrust needle roller and cage assembly which can be calculated from:

$$F_{a \text{ min}} = C_0 / 2200 \text{ [kN]}$$

Where:

- C_0 = static load rating [kN]
- $F_{a \text{ min}}$ = minimum axial load [kN]

COEFFICIENT OF FRICTION

In general, the coefficient of friction of a thrust bearing (consisting of a thrust needle roller and cage assembly and thrust washers) is defined as the friction torque, divided by the product of the applied load and the bearing pitch radius. This coefficient of friction is not a constant value, but will vary considerably with load, speed and lubricant. Generally, the coefficient of friction becomes smaller as the load is increased, and larger as the speed is increased. It is suggested that a value of 0.003 to 0.004 be used for needle thrust bearings and 0.004 to 0.005 be used for cylindrical roller thrust bearings as a conservative estimate.

LUBRICATION

Oil is the preferred lubricant for thrust needle roller and cage assemblies and an ample oil flow is absolutely necessary for high speeds or for moderate speeds when the load is relatively high.

When the application must utilize grease lubrication, the thrust needle roller and cage assembly should be ordered pre-greased. When the speeds are low and rotation is not continuous, the initial charge of grease may be suitable for the life of the application. When the speeds are moderate, the designer must provide for frequent re-greasing. Because the needle rollers tend to expel the lubricant radially outward, re-lubrication passages should be directed to the bore of the cage whether oil or grease is used as the lubricant.

SPECIAL DESIGNS

Thrust needle roller and cage assemblies and thrust washers are made to special dimensions and configurations, as well as from special materials – when quantities permit economical manufacture.

Thrust needle roller and cage assemblies are particularly adaptable to low-cost integral combination with special thrust washers. When the use of such special designs is considered, the following pages should be reviewed for evaluation of proposed arrangements.

UNITIZED THRUST BEARING TYPE FNTKF

METRIC SERIES

- Combines low friction and thin cross section with the convenience of complete packaged assembly.
- Used where both thrust backup surfaces are not suitably hardened or ground.
- Backup surfaces should meet limits of permissible out-of-squareness, dishing or coning. (See page B-276 for details on piloting and backup surfaces.)
- Assembly can be either shaft- or housing-piloted, but not both (see mounting dimensions shown).
- Many special sizes available. Contact your representative for availability.

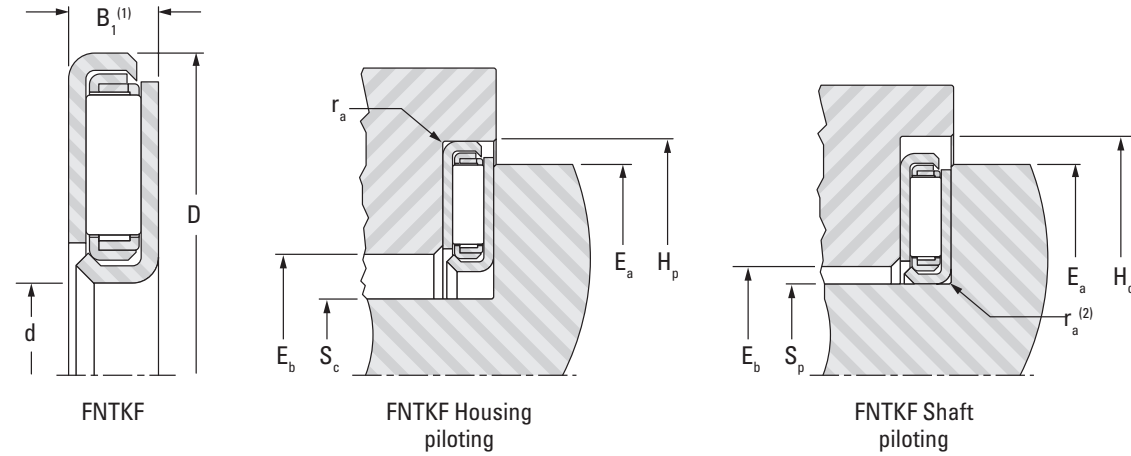

Shaft Dia.	d	D	B ₁ ⁽¹⁾	Assembly Designation	C	C ₀	Speed Rating Oil	Mounting Dimensions				Contact Dimensions Nominal	
								Housing Piloting		Shaft Piloting		E _a	
	Load Ratings		H10					Max.	h10	Min.	mm in	mm in	
	Dynamic	Static											mm in
10	10 0.3937	28 1.1024	3.7 0.146	FNTKF-1028	9.88 2220	29.0 6520	16000	28 1.102	8 0.31496	10 0.394	30 1.181	25 0.984	14 0.551
13	13 0.5118	30 1.1811	3.7 0.146	FNTKF-1330	10.1 2270	31.3 7040	15000	30 1.181	11 0.433	13 0.512	32 1.260	27 1.063	17 0.669
15	15 0.5906	32 1.2598	3.7 0.146	FNTKF-1532	10.8 2430	34.8 7820	14000	32 1.260	13 0.512	15 0.591	34 1.339	29 1.142	19 0.748
18	18 0.7087	37 1.4567	3.7 0.146	FNTKF-1837	13.8 3100	50.3 11300	12000	37 1.457	16 0.630	18 0.709	39 1.535	34 1.339	22 0.866
23	23 0.9055	44 1.7323	3.7 0.146	FNTKF-2344	18.0 4050	75.3 16900	9700	44 1.732	21 0.827	23 0.906	46 1.811	41 1.614	27 1.063
28	28 1.1024	49 1.9291	3.7 0.146	FNTKF-2849	18.6 4180	82.4 18500	8900	49 1.929	26 1.024	28 1.102	51 2.008	46 1.811	32 1.260
33	33 1.2992	54 2.126	3.7 0.146	FNTKF-3354	21.6 4860	104 23400	7900	54 2.126	31 1.220	33 1.299	56 2.205	51 2.008	37 1.457
38	38 1.4961	62 2.4409	4.7 0.185	FNTKF-3862	31.4 7060	132 29700	7100	62 2.441	36 1.417	38 1.496	64 2.520	57 2.244	43 1.693
43	43 1.6929	67 2.6378	4.7 0.185	FNTKF-4367	37.8 8500	173 38900	6400	67 2.638	41 1.614	43 1.693	69 2.717	63 2.480	47 1.850
48	48 1.890	72 2.8346	4.7 0.185	FNTKF-4872	37.9 8520	179 40200	5900	72 2.835	46 1.811	48 1.890	74 2.913	68 2.677	52 2.047
53	53 2.0866	80 3.150	4.7 0.185	FNTKF-5380	48.5 10900	254 57100	5300	80 3.150	51 2.008	53 2.087	82 3.228	76 2.992	57 2.244

⁽¹⁾ To be measured under a 2.0 kN (450 lbf) load.
⁽²⁾ r_a = 1.000 mm max. (0.0394 in max.).

UNITIZED THRUST BEARING TYPE FNTK

METRIC SERIES

- Combine low friction and thin cross section with the convenience of complete packaged assembly.
- Integral washer allows use where one thrust backup surface is not suitably hardened or ground.
- Backup surface should meet limits of permissible out-of-squareness, dishing or coning. (See page B-276 for details on piloting and backup surfaces.)
- Backup surface finish of 0.2 μm Ra min. (8 μin Ra min.) required.
- Assembly can be either shaft- or housing-piloted, but not both (See mounting dimensions shown).
- Many special sizes available. Contact your representative for availability.

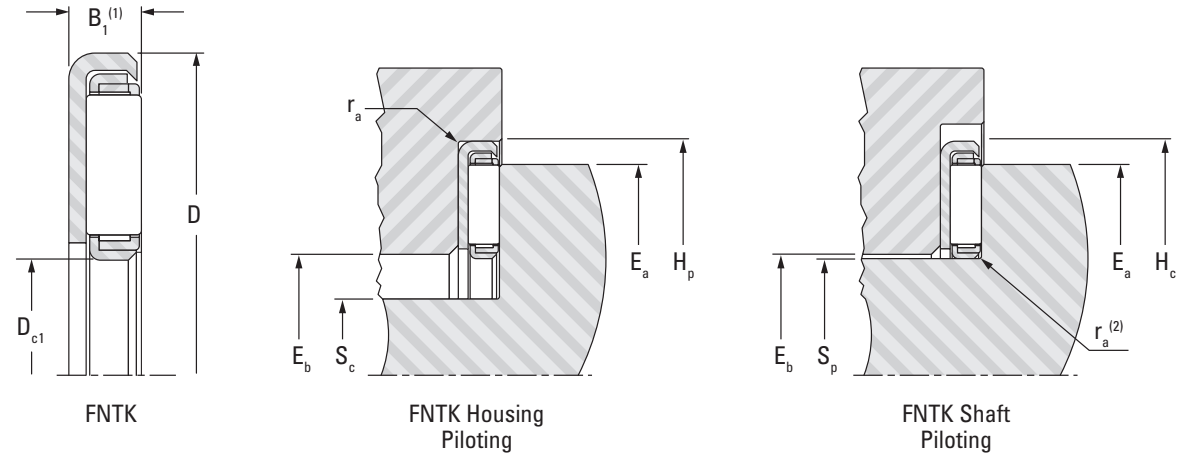

Shaft Dia.	D _{c1}	D	B ₁ ⁽¹⁾	Assembly Designation	C	C ₀	Speed Rating Oil	Mounting Dimensions				Contact Dimensions Nominal	
								Housing Piloting		Shaft Piloting		E _a	
	Load Ratings		H10					Max.	h10	Min.	mm in	mm in	
	Dynamic	Static											mm in
12	12 0.4724	28 1.1024	2.85 0.1122	FNTK-1228	9.88 2220	29.0 6520	16000	28 1.102	10.5 0.413	12 0.4724	29.5 1.161	25 0.9843	14 0.5512
15	15 0.5906	30 1.1811	2.85 0.1122	FNTK-1530	10.1 2270	31.3 7040	15000	30 1.181	13.5 0.531	15 0.5906	31.5 1.240	27 1.063	17 0.6693
17	17 0.6693	32 1.260	2.85 0.1122	FNTK-1732	10.8 2430	34.8 7820	14000	32 1.260	15.5 0.610	17 0.6693	33.5 1.319	29 1.1417	19 0.748
20	20 0.7874	37 1.4567	2.85 0.1122	FNTK-2037	13.8 3100	50.3 11300	12000	37 1.457	18.5 0.728	20 0.7874	38.5 1.516	34 1.3386	22 0.8661
25	25 0.9843	44 1.7323	2.85 0.1122	FNTK-2544	18.0 4050	75.3 16900	9700	44 1.732	23.5 0.925	25 0.9843	45.5 1.791	41 1.6142	27 1.063
30	30 1.1811	49 1.9291	2.85 0.1122	FNTK-3049	18.6 4180	82.4 18500	8900	49 1.929	28.5 1.122	30 1.1811	50.5 1.988	46 1.811	32 1.260
35	35 1.378	54 2.126	2.85 0.1122	FNTK-3554	21.6 4860	104 23400	7900	54 2.126	33.5 1.319	35 1.378	55.5 2.185	51 2.0079	37 1.4567
40	40 1.5748	62 2.4409	3.85 0.1516	FNTK-4062	31.4 7060	132 29700	7100	62 2.441	38.5 1.516	40 1.5748	63.5 2.500	57 2.2441	43 1.6929
45	45 1.7717	67 2.6378	3.85 0.1516	FNTK-4567	37.8 8500	173 38900	6400	67 2.638	43.5 1.713	45 1.7717	68.5 2.697	63 2.480	47 1.850
50	50 1.9685	72 2.8346	3.85 0.1516	FNTK-5072	37.9 8520	179 40200	5900	72 2.835	48.5 1.909	50 1.9685	73.5 2.894	68 2.6772	52 2.0472
55	55 2.1654	80 3.150	3.85 0.1516	FNTK-5580	48.5 10900	254 57100	5300	80 3.150	53.5 2.106	55 2.1654	81.5 3.209	76 2.9921	57 2.2441

⁽¹⁾ To be measured under a 2.0 kN (450 lbf) load.
⁽²⁾ r_a = 1.000 mm max. (0.0394 in max.).

UNITIZED THRUST BEARING TYPE FNTF

METRIC SERIES

- Combines low friction and thin cross section with the convenience of complete packaged assembly.
- Integral washer allows use where one thrust backup surface is not suitably hardened or ground.
- Backup surface should meet limits of permissible out-of-squareness, dishing or coning. (See page B-276 for details on piloting and backup surfaces.)
- Backup surface finish of 0.2 μm Ra min. (8 μin Ra min.) required.
- Assembly can be either shaft- or housing-piloted, but not both (see mounting dimensions shown on the opposite page).
- Many special sizes available. Contact your representative for availability.

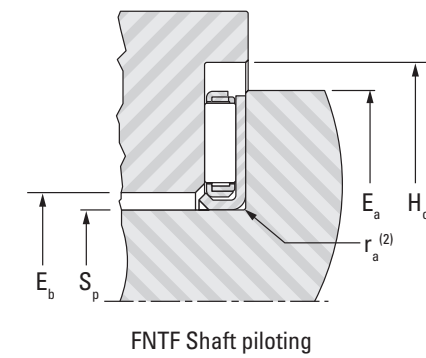
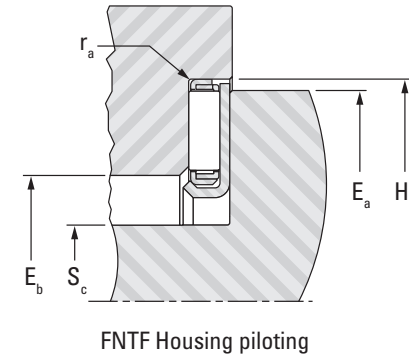
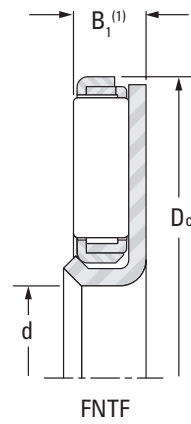

Shaft Dia.	d	Dc	B ₁ ⁽¹⁾	Assembly Designation	Load Ratings		Speed Rating Oil
					C		
	(E13)	(c12)	-0.1, -0.004		Dynamic	Static	
mm	mm	mm	mm		kN		
	in	in	in		lbf		
10	10 0.394	26 1.024	2.85 0.112	FNTF-1026	9.88 2220	29.0 6520	16000
13	13 0.512	28 1.102	2.85 0.112	FNTF-1328	10.1 2270	31.3 7040	15000
15	15 0.591	30 1.181	2.85 0.112	FNTF-1530	10.8 2430	34.8 7820	14000
18	18 0.709	35 1.378	2.85 0.112	FNTF-1835	13.8 3100	50.3 11300	12000
23	23 0.906	42 1.654	2.85 0.112	FNTF-2342	18.0 4050	75.3 16900	9700
28	28 1.102	47 1.850	2.85 0.112	FNTF-2847	18.6 4180	82.4 18500	8900
33	33 1.299	52 2.047	2.85 0.112	FNTF-3352	21.6 4860	104 23400	7900
38	38 1.496	60 2.362	3.85 0.152	FNTF-3860	31.4 7060	132 29700	7100
43	43 1.693	65 2.559	3.85 0.152	FNTF-4365	37.8 8500	173 38900	6400
48	48 1.890	70 2.756	3.85 0.152	FNTF-4870	37.9 8520	179 40200	5900
53	53 2.087	78 3.071	3.85 0.152	FNTF-5378	48.5 10900	254 57100	5300

H _p	S _c	S _p	H _c	E _a	E _b
Housing Piloting		Mounting Dimensions Shaft Piloting		Contact Dimensions	
H10	Max.	h10	Min.	Nom.	Nom.
mm in	mm in	mm in	mm in	mm in	mm in
26 1.024	8.5 0.335	10 0.394	27.5 1.083	25 0.984	14 0.551
28 1.102	11.5 0.453	13 0.512	29.5 1.161	27 1.063	17 0.669
30 1.181	13.5 0.531	15 0.591	31.5 1.240	29 1.142	19 0.748
35 1.378	16.5 0.650	18 0.709	36.5 1.437	34 1.339	22 0.866
42 1.654	21.5 0.846	23 0.906	43.5 1.713	41 1.614	27 1.063
47 1.850	26.5 1.043	28 1.102	48.5 1.909	46 1.811	32 1.260
52 2.047	31.5 1.240	33 1.299	53.5 2.106	51 2.008	37 1.457
60 2.362	36.5 1.437	38 1.496	61.5 2.421	57 2.244	43 1.693
65 2.559	41.5 1.634	43 1.693	66.5 2.618	63 2.480	47 1.850
70 2.756	46.5 1.831	48 1.890	71.5 2.815	68 2.677	52 2.047
78 3.071	51.5 2.028	53 2.087	79.5 3.130	76 2.992	57 2.244

⁽¹⁾ To be measured under a 2.0 kN (450 lbf) load.
⁽²⁾ r_a = 1.000 mm max. (0.0394 in max.).

UNITIZED THRUST BEARINGS TYPE AX

METRIC SERIES

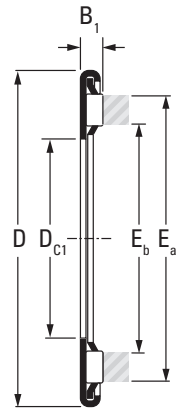

AX Thin series

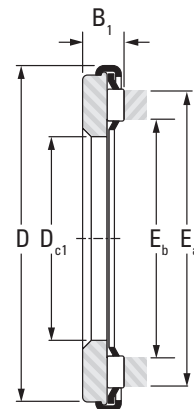

AX Thick series

Shaft Dia.	D _{c1}	D	E _a	E _b	B ₁	Bearing Designation	Wt.	C		Speed Rating Oil
								Load Ratings		
	mm	Bearing Dimensions					Thin	Thick	Dynamic	Static
5	5	13	10.9	6.3	2.3	AX 5 13	0.001 0.002	3.00 670	5.70 1280	25000
5	5	13	10.9	6.3	3.5	AX 3,5 5 13	0.002 0.004	3.00 670	5.70 1280	25000
6	6	14	11.9	7.3	2.3	AX 6 14	0.001 0.002	3.15 710	6.35 1430	22000
	6	14	11.9	7.3	3.5	AX 3,5 6 14	0.002 0.004	3.15 710	6.35 1430	22000
7	7	15	12.9	8.3	2.3	AX 7 15	0.002 0.004	3.55 800	7.60 1710	22000
	7	15	12.9	8.3	3.5	AX 3,5 7 15	0.003 0.007	3.55 800	7.60 1710	22000
8	8	16	13.9	9.3	2.3	AX 8 16	0.002 0.004	3.70 830	8.30 1870	22000
	8	16	13.9	9.3	3.5	AX 3,5 8 16	0.003 0.007	3.70 830	8.30 1870	22000
9	9	17	14.9	10.3	2.3	AX 9 17	0.002 0.004	4.05 910	9.50 2140	19000
	9	17	14.9	10.3	3.5	AX 3,5 9 17	0.004 0.009	4.05 910	9.50 2140	19000
10	10	22	18.6	12.0	4.0	AX 4 10 22	0.007 0.015	5.00 1120	10.90 2450	15500
12	12	26	22.6	15.0	2.8	AX 12 26	0.006 0.013	6.90 1550	17.70 3980	13000
	12	26	22.6	15.0	4.0	AX 4 12 26	0.010 0.022	6.90 1550	17.70 3980	13000
13	13	26	22.6	15.0	2.8	AX 13 26	0.006 0.013	6.90 1550	17.70 3980	13000
	13	26	22.6	15.0	4.0	AX 4 13 26	0.010 0.022	6.90 1550	17.70 3980	13000
15	15	28	24.6	17.0	2.8	AX 15 28	0.007 0.015	7.40 1660	20.00 4500	11500



CP Thin series

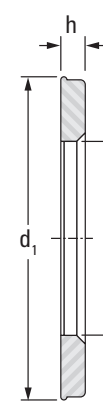

CP Thick series

d	d ₁	h	Wt.	Washer Designation		Washer Designation Precision	h	Precision Wt.	Shaft Dia.
				Thin	Thick				
Washer Dimensions			kg lbs			mm in	kg lbs	mm	
5	12.4	0.8	0.001 0.002	CP 5 13					5
5	12.4	2.0	0.002 0.004		CP 2 5 13				
6	13.4	0.8	0.001 0.002	CP 6 14					6
6	13.4	2.0	0.002 0.004		CP 2 6 14				
7	14.4	0.8	0.001 0.002	CP 7 15					7
7	14.4	2.0	0.002 0.004		CP 2 7 15				
8	15.4	0.8	0.001 0.002	CP 8 16					8
8	15.4	2.0	0.002 0.004		CP 2 8 16				
9	16.4	0.8	0.001 0.002	CP 9 17					9
9	16.4	2.0	0.002 0.004		CP 2 9 17				
10	21.5	2.0	0.002 0.004		CP 2 10 22				10
12	25.5	0.8	0.003 0.007	CP 12 26		CPN 2 12 26	2.0 0.079	0.006 0.013	12
12	25.5	2.0	0.006 0.013		CP 2 12 26				
13	25.5	0.8	0.002 0.004	CP 13 26					13
13	25.5	2.0	0.006 0.013		CP 2 13 26				
15	27.5	0.8	0.003 0.007	CP 15 28		CPN 2 15 28	2.0 0.079	0.006 0.013	15

Continued on next page.



UNITIZED THRUST BEARINGS

TYPE AX — continued

METRIC SERIES

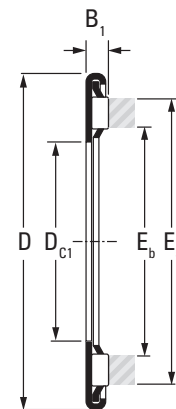

AX Thin series

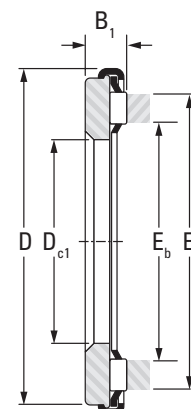

AX Thick series

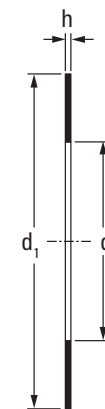

CP Thin series

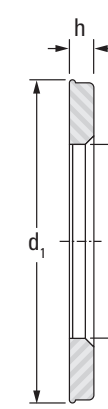

CP Thick series

Shaft Dia.	D _{c1}	D	E _a	E _b	B ₁	Bearing Designation		Wt.	C		Speed Rating Oil
						Thin	Thick		Load Ratings		
	mm	mm in	mm in	mm in	mm in			mm in		Dynamic	Static
15	15	28	24.6	17.0	4.0	AX 4 15 28	0.009	7.40	20.00	11500	
	0.591	1.102	0.97	0.67	0.158			1660	4500		
17	17	30	26.6	19.0	2.8	AX 17 30	0.008	7.80	22.00	10500	
	0.669	1.181	1.05	0.75	0.110			1750	4950		
17	17	30	26.6	19.0	4.0	AX 4 17 30	0.010	7.80	22.00	10500	
	0.669	1.181	1.05	0.75	0.158			1750	4950		
19	19	32	28.6	21.0	2.8	AX 19 32	0.009	8.00	23.30	10000	
	0.748	1.260	1.13	0.83	0.110			1800	5240		
19	19	32	28.6	21.0	4.0	AX 4 19 32	0.013	8.00	23.30	10000	
	0.748	1.260	1.13	0.83	0.158			1800	5240		
20	20	35	31.6	22.0	5.0	AX 5 20 35	0.018	11.80	39.00	9000	
	0.787	1.378	1.24	0.87	0.197			2650	8770		
25	25	42	37.4	27.7	2.8	AX 25 42	0.012	13.30	49.00	7500	
	0.984	1.654	1.47	1.09	0.110			2990	11000		
25	25	42	37.4	27.7	5.0	AX 5 25 42	0.025	13.30	49.00	7500	
	0.984	1.654	1.47	1.09	0.197			2990	11000		
27	27	44	39.6	30.0	2.8	AX 27 44	0.012	13.70	52.00	7200	
	1.063	1.732	1.56	1.18	0.110			3080	11700		
30	30	47	42.4	32.7	2.8	AX 30 47	0.014	14.50	57.00	6500	
	1.181	1.850	1.67	1.29	0.110			3260	12800		
30	30	47	42.4	32.7	5.0	AX 5 30 47	0.029	14.50	57.00	6500	
	1.181	1.850	1.67	1.29	0.197			3260	12800		
35	35	52	49.0	37.2	2.8	AX 35 52	0.019	18.90	84.00	5500	
	1.337	2.047	1.93	1.47	0.110			4250	18900		
35	35	52	49.0	37.2	5.0	AX 5 35 52	0.035	18.90	84.00	5500	
	1.337	2.047	1.93	1.47	0.197			4250	18900		
35	35	53	49.0	37.2	2.8	AX 35 53	0.019	18.90	84.00	5500	
	1.337	2.087	1.93	1.47	0.110			4250	18900		
35	35	53	49.0	37.2	5.0	AX 5 35 53	0.036	18.90	84.00	5500	
	1.337	2.087	1.93	1.47	0.197			4250	18900		

d	d ₁	h	Wt.	Washer Designation		Washer Designation Precision	h	Precision Wt.	Shaft Dia.
				Thin	Thick				
	mm	mm in	mm in			kg lbs			mm in
15	27.5	2.0	0.006		CP 2 15 28				
0.591	1.083	0.079	0.013						
17	29.5	0.8	0.003	CP 17 30		CPN 7 17 30	7.0	0.025	17
0.669	1.161	0.032	0.007				0.276	0.055	
17	29.5	2.0	0.007		CP 2 17 30				
0.669	1.161	0.079	0.015						
19	31.5	0.8	0.004	CP 19 32					19
0.748	1.240	0.032	0.009						
19	31.5	2.0	0.009		CP 2 19 32				
0.748	1.240	0.079	0.020						
20	34.5	3.0	0.013		CP 3 20 35	CPN 3 20 35	3.0	0.013	20
0.787	1.358	0.118	0.029				0.118	0.029	
25	41.5	0.8	0.005	CP 25 42		CPN 3 25 42	3.0	0.019	25
0.984	1.634	0.032	0.011				0.118	0.042	
25	41.5	3.0	0.019		CP 3 25 42				
0.984	1.634	0.118	0.042						
27	43.7	0.8	0.006	CP 27 44					27
1.063	1.721	0.032	0.013						
30	46.5	0.8	0.006	CP 30 47		CPN 5 30 47	5.0	0.037	30
1.181	1.831	0.032	0.013				0.197	0.082	
30	46.5	3.0	0.022		CP 3 30 47				
1.181	1.831	0.118	0.049						
35	51.5	0.8	0.007	CP 35 52		CPN 3 35 52	3.0	0.027	31
1.378	2.028	0.032	0.015				0.118	0.060	
35	51.5	3.0	0.026		CP 3 35 52				35
1.378	2.028	0.118	0.057						
35	52.5	0.8	0.007	CP 35 53					
1.378	2.067	0.032	0.015						
35	52.5	3.0	0.027		CP 3 35 53				
1.378	2.067	0.118	0.060						

Continued on next page.

UNITIZED THRUST BEARINGS
TYPE AX – continued

METRIC SERIES

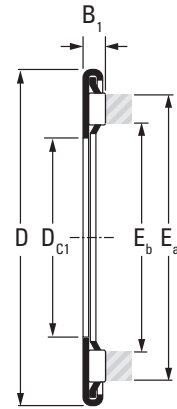

AX Thin series

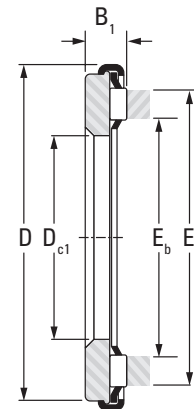

AX Thick series

Shaft Dia.	D _{c1}	D	E _a	E _b	B ₁	Bearing Designation	Wt.	C		Speed Rating Oil	
								Load Ratings			min ⁻¹
								Dynamic	Static		
	Bearing Dimensions					Thin	Thick	kN lbf			
mm	mm in	mm in	mm in	mm in	mm in		kg lbs				
40	40 1.557	60 2.362	54.9 2.16	43.0 1.69	2.8 0.110	AX 40 60	0.024 0.053	20.40 4590	96.00 21600	5000	
	40 1.557	60 2.362	54.9 2.16	43.0 1.69	5.0 0.197	AX 5 40 60	0.046 0.101	20.40 4590	96.00 21600	5000	
45	45 1.772	65 2.559	59.9 2.36	48.0 1.89	2.8 0.110	AX 45 65	0.025 0.055	21.80 4900	109 24500	4500	
	45 1.772	65 2.559	59.9 2.36	48.0 1.89	5.0 0.197	AX 5 45 65	0.050 0.110	21.80 4900	109 24500	4500	
50	50 1.969	70 2.756	65.7 2.59	53.3 2.10	2.8 0.110	AX 50 70	0.026 0.057	22.50 5060	118 26500	4000	
	50 1.969	70 2.756	65.7 2.59	53.3 2.10	5.0 0.197	AX 5 50 70	0.055 0.121	22.50 5060	118 26500	4000	
55	55 2.165	78 3.071	72.5 2.85	58.4 2.30	2.8 0.110	AX 55 78	0.034 0.075	28.50 6410	164 36900	3800	
	55 2.165	78 3.071	72.5 2.85	58.4 2.30	6.0 0.236	AX 6 55 78	0.089 0.196	28.50 6410	164 36900	3800	
60	60 2.362	85 3.347	79.2 3.12	63.5 2.50	6.0 0.236	AX 6 60 85	0.106 0.234	31.50 7080	193 43400	3500	
65	65 2.559	90 3.543	84.2 3.32	68.5 2.70	3.5 0.138	AX 3,5 65 90	0.059 0.130	33.50 7530	210 47200	3200	
	65 2.559	90 3.543	84.2 3.32	68.5 2.70	6.0 0.236	AX 6 65 90	0.114 0.251	33.50 7530	210 47200	3200	
70	70 2.759	95 3.740	89.2 3.51	73.5 2.89	3.5 0.138	AX 3,5 70 95	0.061 0.135	34.50 7760	223 50100	3000	
	70 2.759	95 3.740	89.2 3.51	73.5 2.89	6.0 0.236	AX 6 70 95	0.120 0.265	34.50 7760	223 50100	3000	
75	75 2.953	100 3.937	94.2 3.71	78.5 3.09	3.5 0.138	AX 3,5 75 100	0.065 0.143	36.00 8090	240 54000	2900	
	75 2.953	100 3.937	94.2 3.71	78.5 3.09	6.0 0.236	AX 6 75 100	0.127 0.280	36.00 8090	240 54000	2900	
80	80 3.150	105 4.134	99.2 3.91	83.5 3.29	3.5 0.138	AX 3,5 80 105	0.069 0.152	36.50 8210	253 56900	2700	
	80 3.150	105 4.134	99.2 3.91	83.5 3.29	6.0 0.236	AX 6 80 105	0.134 0.295	36.50 8210	253 56900	2700	
85	85 3.347	110 4.331	104.2 4.10	88.5 3.48	3.5 0.138	AX 3,5 85 110	0.078 0.172	38.00 8540	270 60700	2600	

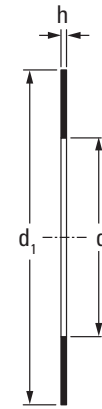

CP Thin series

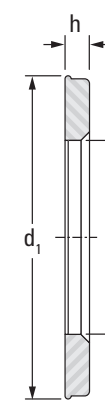

CP Thick series

d	d ₁	h	Wt.	Washer Designation		Washer Designation Precision	h	Precision Wt.	Shaft Dia.
				Thin	Thick				
				Washer Dimensions					
mm in	mm in	mm in	kg lbs			mm in	kg lbs	mm	
40	59.5 1.575	0.8 0.032	0.009 0.020	CP 40 60	CPN 3 40 60	3.0 0.118	0.034 0.075	40	
40	59.5 1.575	3.0 0.118	0.034 0.075		CP 3 40 60				
45	64.4 1.772	0.8 0.032	0.010 0.022	CP 45 65	CPN 3 45 65	3.0 0.118	0.037 0.082	45	
45	64.4 1.772	3.0 0.118	0.037 0.082		CP 3 45 65				
50	69.4 1.969	0.8 0.032	0.011 0.024	CP 50 70				50	
50	69.4 1.969	3.0 0.118	0.040 0.088		CP 3 50 70				
55	77.4 2.165	0.8 0.032	0.014 0.031	CP 55 78				55	
55	77.4 2.165	4.0 0.158	0.069 0.152		CP 4 55 78				
60	84.3 2.362	4.0 0.158	0.083 0.183		CP 4 60 85			60	
65	89.3 2.559	1.5 0.059	0.033 0.073	CP 1,5 65 90				65	
65	89.3 2.559	4.0 0.158	0.088 0.194		CP 4 65 90				
70	94.3 2.756	1.5 0.059	0.034 0.075	CP 1,5 70 95	CPN 4 70 95	4.0 0.158	0.093 0.205	70	
70	94.3 2.756	4.0 0.158	0.093 0.205		CP 4 70 95				
75	99.3 2.953	1.5 0.059	0.037 0.082	CP 1,5 75 100				75	
75	99.3 2.953	4.0 0.158	0.099 0.218		CP 4 75 100				
80	104.3 3.150	1.5 0.059	0.039 0.086	CP 1,5 80 105				80	
80	104.3 3.150	4.0 0.158	0.104 0.229		CP 4 80 105				
85	109.3 3.347	1.5 0.059	0.047 0.104	CP 1,5 85 110				85	

Continued on next page.

UNITIZED THRUST BEARINGS
TYPE AX — *continued*

METRIC SERIES

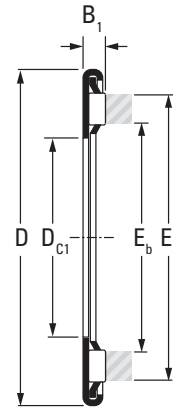

AX Thin series

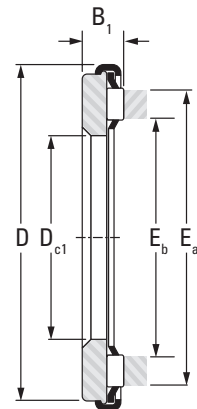

AX Thick series

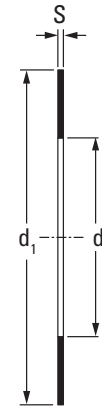

CP Thin series

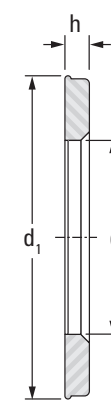

CP Thick series

Shaft Dia.	D _{c1}	D	E _a	E _b	B ₁	Bearing Designation		Wt.	C		C _o	Speed Rating Oil
						Thin	Thick		Load Ratings			
	Bearing Dimensions								Dynamic	Static		
mm	mm in	mm in	mm in	mm in	mm in			kg lbs	kN lbf			min ⁻¹
85	85 3.347	110 4.331	104.2 4.10	88.5 3.48	6.0 0.236		AX 6 85 110	0.142 0.313	38.00 8540	270 60700		2600
90	90 3.543	120 4.724	112.9 4.45	94.2 3.71	4.5 0.177		AX 4,5 90 120	0.117 0.258	59.00 13300	360 80900		2400
	90 3.543	120 4.724	112.9 4.45	94.2 3.71	8.0 0.315		AX 8 90 120	0.238 0.525	59.00 13300	360 80900		2400
100	100 3.937	135 5.315	127.3 5.01	104.2 4.10	9.0 0.354		AX 9 100 135	0.364 0.803	73.00 16400	490 110000		2100
110	110 4.331	145 5.709	137.3 5.41	114.2 4.50	4.5 0.177		AX 4,5 110 145	0.168 0.370	77.00 17300	550 124000		2000
	110 4.331	145 5.709	137.3 5.41	114.2 4.50	9.0 0.354		AX 9 110 145	0.393 0.867	77.00 17300	550 124000		2000
120	120 4.724	155 6.102	147.3 5.80	124.2 4.89	4.5 0.177		AX 4,5 120 155	0.182 0.401	80.00 18000	590 133000		1800
	120 4.724	155 6.102	147.3 5.80	124.2 4.89	9.0 0.354		AX 9 120 155	0.424 0.935	80.00 18000	590 133000		1800
130	130 5.118	170 6.693	161.0 6.34	135.0 5.32	11.0 0.433		AX 11 130 170	0.660 1.455	106 23800	710 160000		1700
140	140 5.512	180 7.087	171.0 6.73	145.0 5.71	9.0 0.354		AX 11 140 180	0.670 1.477	111 25000	770 173000		1600
150	150 5.906	190 7.480	181.0 7.13	155.0 6.10	9.0 0.354		AX 11 150 190	0.710 1.566	115 25900	830 187000		1500
160	160 6.299	200 7.874	191.0 7.52	165.0 6.50	9.0 0.354		AX 11 160 200	0.760 1.676	118 26500	870 196000		1400
170	170 6.693	215 8.465	207.0 8.15	175.0 6.89	12.0 0.472		AX 12 170 215	1.000 2.205	165 37100	1160 261000		1300
180	180 7.087	225 8.858	217.0 8.54	185.0 7.28	12.0 0.472		AX 12 180 225	1.050 2.315	173 38900	1250 281000		1200
190	190 7.480	240 9.449	232.0 9.13	196.0 7.72	13.9 0.547		AX 14 190 240	1.400 3.087	230 51700	1650 371000		1200
200	200 7.874	250 9.843	242.0 9.53	206.0 8.11	13.9 0.547		AX 14 200 250	1.500 3.308	239 53700	1730 389000		1100
220	220 8.661	270 10.630	262.0 10.32	226.0 8.90	13.9 0.547		AX 14 220 270	1.600 3.528	248 55800	1850 416000		1000
240	240 9.449	300 11.811	286.0 11.26	246.0 9.69	14.9 0.587		AX 15 240 300	2.300 5.072	280 62900	2240 504000		900

d	d ₁	h	Wt.	Washer Designation		Washer Designation Precision	h	Precision Wt.	Shaft Dia.
				Thin	Thick				
Washer Dimensions			kg lbs			mm in	kg lbs	mm	
mm in	mm in	mm in							
85 3.347	109.3 4.303	4.0 0.158	0.111 0.245		CP 4 85 110				
90 3.543	118.8 4.677	1.5 0.059	0.052 0.115		CP 1,5 90 120			90	
90 3.543	118.8 4.677	5.0 0.197	0.173 0.381		CP 5 90 120				
100 3.937	133.8 5.268	6.0 0.236	0.277 0.611		CP 6 100 135			100	
110 4.331	143.8 5.661	1.5 0.059	0.075 0.165		CP 1,5 110 145			110	
110 4.331	143.8 5.661	6.0 0.236	0.300 0.662		CP 6 110 145				
120 4.724	153.8 6.055	1.5 0.059	0.081 0.179		CP 1,5 120 155			120	
120 4.724	153.8 6.055	6.0 0.236	0.323 0.712		CP 6 120 155				
130 5.118	168.7 6.642	7.0 0.276	0.480 1.058		CP 7 130 170			130	
140 5.512	178.7 7.035	7.0 0.276	0.500 1.103		CP 7 140 180			140	
150 5.906	188.7 7.429	7.0 0.276	0.530 1.169		CP 7 150 190			150	
160 6.299	198.7 7.823	7.0 0.276	0.560 1.235		CP 7 160 200			160	
170 6.693	213.5 8.406	7.0 0.276	0.700 1.544		CP 7 170 215			170	
180 7.087	223.5 8.799	7.0 0.276	0.735 1.621		CP 7 180 225			180	
190 7.480	238.3 9.382	8.0 0.315	0.950 2.095		CP 8 190 240			190	
200 7.874	248.3 9.776	8.0 0.315	1.000 2.205		CP 8 200 250			200	
220 8.661	268.3 10.563	8.0 0.315	1.100 2.426		CP 8 220 270			220	
240 9.449	298.5 11.752	9.0 0.354	1.600 3.528		CP 9 240 300			240	

CYLINDRICAL ROLLER THRUST BEARINGS AND THEIR COMPONENTS

METRIC SERIES

Cylindrical roller thrust bearings provide rolling bearing arrangements that accommodate high-dynamic axial loads. The simple geometry of the bearing components allows the use of many design arrangements. As an example, for less demanding applications, it is possible to combine metric series, thrust cylindrical roller and cage assemblies, including the metric series heavy thrust washers (LS,CPR) and even the metric series thin thrust washers (AS, CP). These two thrust washer types are more commonly used with thrust needle roller and cage assemblies. Thrust cylindrical roller and cage assemblies also can be used without bearing thrust washers if the adjacent machine components can be prepared to serve as suitable raceways.

Cylindrical roller thrust bearings may be used where the load carrying capability of thrust needle roller and cage assemblies is insufficient. Also, the bearings can accommodate high-dynamic and static axial loads in one direction, but they are not suitable to transmit radial loads.

REFERENCE STANDARDS ARE:

- **ISO 104** – rolling bearings – thrust bearings – boundary dimensions, general plan.
- **ISO 199** – rolling bearings – thrust bearings – tolerances.
- **DIN 616** – rolling bearings – general plan for boundary dimensions.
- **DIN 722** – rolling bearing – thrust cylindrical roller bearings – single direction.

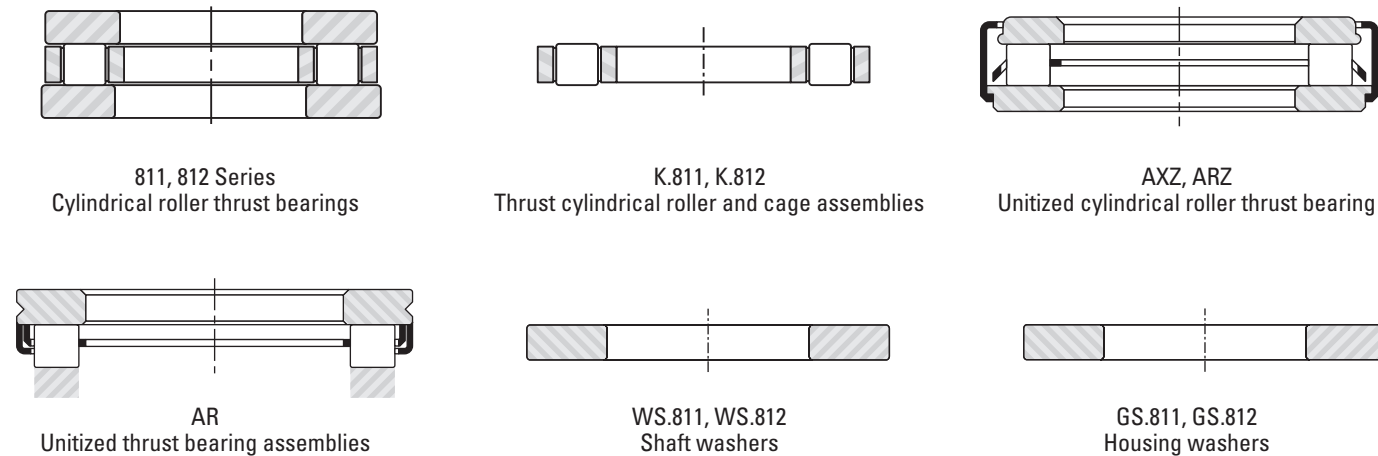

Fig. B-73. Types of metric series cylindrical roller thrust bearings and their components

Suffixes	
LPB	Machined light metal window-type cage.
TVP	Molded window-type cage of glass reinforced nylon.

CONSTRUCTION

BASIC DESIGNS

Cylindrical roller thrust bearings of dimension series 811 and 812 comprise a thrust cylindrical roller and cage assembly (K), a shaft washer (WS) and a housing washer (GS). Providing the backup surfaces can be hardened and ground, they can be used as raceways for the cylindrical rollers of the thrust cylindrical roller and cage assembly resulting in a compact bearing arrangement.

Series AR is available with thin or thick CP washers or heavy CPR thrust washers.

Thrust bearing types AXZ and ARZ each have two thrust washers retained by an integral cap – giving protection against the entry of dirt and metal particles, while helping to retain the lubricant.

CAGE DESIGNS

Metric series 811 and 812 cylindrical roller thrust bearings use molded cages of glass-fiber reinforced-nylon 6/6 (suffix TVP) or machined cages of light metal (suffix LPB). The cages are designed to be piloted on the shaft. The reinforced nylon cages can be used at temperatures up to 120° C (250° F) continuously for extended periods. When lubricating these bearings with oil, it should be ensured that the oil does not contain additives detrimental to the cage over extended life at operating temperatures higher than 100° C (212° F). Also, care should be exercised that oil change intervals are observed as old oil may reduce cage life at such temperatures.

The rolling elements of the AR series thrust bearings are retained and guided in radial pockets within the cage. The cage is retained in relation to the thrust washer by means of a retaining cap. The design of a one-piece steel cage employs a special curvature that guides the rolling elements, by their ends, along their centerlines.

In addition, this special curvature gives the steel cage great rigidity, while providing maximum lubricant space. This unitized assembly of components facilitates installation and provides a high-axial load capacity while occupying only minimal space.

AR series cylindrical roller thrust bearings with a thin washer are of minimal thickness and provide excellent economy. They should be considered whenever the degree of support and rotational accuracy requirement allow.

BEARING THRUST WASHERS

SHAFT WASHERS AND HOUSING WASHERS

Shaft washers of types WS.811 and WS.812, as well as housing washers of types GS.811 and GS.812, are components of the metric series cylindrical roller thrust bearings of series 811 and 812. They are made of bearing-quality steel – with hardened, precision-ground and lapped-flat raceway surfaces. The tolerances of the thrust bearing bore and outer diameter shown in Table B-50 (1) and Table B-50 (2) (see next page) apply to shaft- and housing-piloted metric series washers.

HEAVY THRUST WASHERS (LS), THIN THRUST WASHERS (AS)

These thrust washers are more frequently used with thrust needle roller and cage assemblies of metric series FNT or AXK. They also are suitable for use with the thrust cylindrical roller and cage assemblies K.811. The heavy thrust washer of series LS are made of bearing-quality steel – hardened and precision-ground on the flat raceway surfaces. The bore and outer diameters of the heavy thrust washers are not ground. Therefore, when used with K.811 type assemblies, they are only suggested where accurate centering is not required. The thin thrust washers of series AS may be used in applications where the loads are light. Both types of these washers are listed in the tabular part of the metric series thrust needle roller and cage assemblies section.

THIN/THICK (CP) AND HEAVY (CPR) THRUST WASHERS

The washer incorporated in the AR series thrust bearing is made from hardened bearing steel and forms one of the raceways for the rolling elements. The opposing raceway is generally provided by a separate thrust washer of similar design supplied by JTEKT. When the AR series thrust bearing is piloted by the revolving part, the thrust washer must be piloted by the stationary part and vice versa. If the revolving part and the stationary part are noticeably eccentric to each other, the thrust bearing with integral washer must – without exception – be piloted by the revolving part.

The second raceway for the rolling elements may also be formed by the face of a shoulder or an inserted washer – provided these have the correct hardness and geometrical dimensions.

DIMENSIONAL ACCURACY

The tolerances for the metric series cylindrical roller thrust bearing bore and outer diameter shown in Table B-50 (1) and B-50 (2) apply to shaft-piloted washers of series WS.811 and WS.812, as well as housing-piloted washers of series GS.811 and GS.812. Tolerances for the bore diameter of series K.811 and K.812 thrust assemblies are given on page B-298.

The tolerances for the bore and outer diameter of series AS thrust washers are shown in Table B-51 below. The tolerances for the bore and outer diameter of series LS thrust washers are given in Table B-53 on page B-297. Bore inspection procedures for thin thrust washers (AS) and heavy thrust washers (LS) are given on page B-274.

Table B-50 (1). Tolerances of cylindrical roller thrust bearings - shaft piloted washer - metric series

Nominal bore diameter d		Tolerance class PO (normal tolerance)				Tolerance class P6				Tolerance class P5			
		Deviations		Variation		Deviations		Variation		Deviations		Variation	
>	≤	Max.	Min.	Max.	Min.	Max.	Min.	Max.	Min.	Max.	Min.	Max.	Min.
mm in	mm in	mm in	mm in	mm in	mm in	mm in	mm in	mm in	mm in	mm in	mm in	mm in	mm in
18.000 0.7087	18.000 0.7087	0.000 0.0000	-0.008 -0.0003	0.006 0.0002	0.010 0.0004	0.000 0.0000	-0.008 -0.0003	0.006 0.0002	0.005 0.0002	0.000 0.0000	-0.008 -0.0003	0.006 0.0002	0.003 0.0001
18.000 0.7087	30.000 1.1811	0.000 0.0000	-0.010 -0.0004	0.008 0.0003	0.010 0.0004	0.000 0.0000	-0.010 -0.0004	0.008 0.0003	0.005 0.0002	0.000 0.0000	-0.010 -0.0004	0.008 0.0003	0.003 0.0001
30.000 1.1811	30.000 1.1811	0.000 0.0000	-0.012 -0.0005	0.009 0.00035	0.010 0.0004	0.000 0.0000	-0.012 -0.0005	0.006 0.00035	0.006 0.0002	0.000 0.0000	-0.012 -0.0005	0.009 0.00035	0.003 0.0001
30.000 1.1811	50.000 1.9685	0.000 0.0000	-0.015 -0.0005	0.011 0.00035	0.010 0.0004	0.000 0.0000	-0.015 -0.0005	0.011 0.00035	0.007 0.0002	0.000 0.0000	-0.015 -0.0005	0.011 0.00035	0.004 0.0001
50.000 1.9685	50.000 1.9685	0.000 0.0000	-0.020 -0.0006	0.015 0.0004	0.010 0.0004	0.000 0.0000	-0.020 -0.0006	0.015 0.0004	0.008 0.0003	0.000 0.0000	-0.020 -0.0006	0.015 0.0004	0.004 0.0002
50.000 1.9685	80.000 3.1496	0.000 0.0000	-0.025 -0.0008	0.019 0.0006	0.015 0.0006	0.000 0.0000	-0.025 -0.0008	0.019 0.0006	0.009 0.0003	0.000 0.0000	-0.025 -0.0008	0.019 0.0006	0.005 0.0002
80.000 3.1496	80.000 3.1496	0.000 0.0000	-0.030 -0.0006	0.023 0.0006	0.020 0.0006	0.000 0.0000	-0.030 -0.0006	0.023 0.0006	0.010 0.0003	0.000 0.0000	-0.030 -0.0006	0.023 0.0006	0.005 0.0002
80.000 3.1496	120.000 4.7244	0.000 0.0000	-0.035 -0.0008	0.026 0.0006	0.025 0.0006	0.000 0.0000	-0.035 -0.0008	0.026 0.0006	0.013 0.0003	0.000 0.0000	-0.035 -0.0008	0.026 0.0006	0.007 0.0002
120.000 4.7244	120.000 4.7244	0.000 0.0000	-0.040 -0.0010	0.030 0.00075	0.030 0.0006	0.000 0.0000	-0.040 -0.0010	0.030 0.00075	0.015 0.00035	0.000 0.0000	-0.040 -0.0010	0.030 0.00075	0.007 0.0002
120.000 4.7244	180.000 7.0866	0.000 0.0000	-0.045 -0.0010	0.034 0.00075	0.030 0.0006	0.000 0.0000	-0.045 -0.0010	0.034 0.00075	0.018 0.00035	0.000 0.0000	-0.045 -0.0010	0.034 0.00075	0.009 0.0002
180.000 7.0866	180.000 7.0866	0.000 0.0000	-0.050 -0.0012	0.040 0.0009	0.030 0.0008	0.000 0.0000	-0.050 -0.0012	0.040 0.0009	0.018 0.0004	0.000 0.0000	-0.050 -0.0012	0.040 0.0009	0.009 0.0002
180.000 7.0866	250.000 9.8425	0.000 0.0000	-0.055 -0.0014	0.045 0.0010	0.035 0.0010	0.000 0.0000	-0.055 -0.0014	0.045 0.0010	0.018 0.0005	0.000 0.0000	-0.055 -0.0014	0.045 0.0010	0.009 0.0003
250.000 9.8425	250.000 9.8425	0.000 0.0000	-0.060 -0.0016	0.050 0.0012	0.040 0.0012	0.000 0.0000	-0.060 -0.0016	0.050 0.0012	0.015 0.0006	0.000 0.0000	-0.060 -0.0016	0.050 0.0012	0.007 0.0003
250.000 9.8425	315.000 12.4016	0.000 0.0000	-0.065 -0.0016	0.055 0.0012	0.045 0.0012	0.000 0.0000	-0.065 -0.0016	0.055 0.0012	0.015 0.0006	0.000 0.0000	-0.065 -0.0016	0.055 0.0012	0.009 0.0003
315.000 12.4016	315.000 12.4016	0.000 0.0000	-0.070 -0.0018	0.060 0.0012	0.050 0.0012	0.000 0.0000	-0.070 -0.0018	0.060 0.0012	0.018 0.0007	0.000 0.0000	-0.070 -0.0018	0.060 0.0012	0.009 0.00035

* The values of the wall thickness variation Se, for the housing piloted washer are identical to Si for the shaft - piloted washers.

Table B-50 (2). Tolerances of cylindrical roller thrust bearings - housing piloted washer - metric series

Nominal outside diameter D		Tolerance class PO (normal tolerance)		Tolerance class P6		Tolerance class P5			
		Deviations		Variation		Deviations		Variation	
>	≤	Max.	Min.	Max.	Min.	Max.	Min.	Max.	Min.
mm in	mm in	mm in	mm in	mm in	mm in	mm in	mm in	mm in	mm in
30.000 1.1811	30.000 1.1811	0.000 0.0000	-0.013 -0.0005	0.010 0.0004	0.010 0.0004	0.000 0.0000	-0.013 -0.0005	0.010 0.0004	0.010 0.0004
30.000 1.1811	50.000 1.9685	0.000 0.0000	-0.016 -0.0006	0.012 0.0005	0.012 0.0005	0.000 0.0000	-0.016 -0.0006	0.012 0.0005	0.012 0.0005
50.000 1.9685	50.000 1.9685	0.000 0.0000	-0.019 -0.00075	0.014 0.00055	0.014 0.00055	0.000 0.0000	-0.019 -0.00075	0.014 0.00055	0.014 0.00055
50.000 1.9685	80.000 3.1496	0.000 0.0000	-0.022 -0.0009	0.017 0.0007	0.017 0.0007	0.000 0.0000	-0.022 -0.0009	0.017 0.0007	0.017 0.0007
80.000 3.1496	80.000 3.1496	0.000 0.0000	-0.025 -0.0010	0.019 0.00075	0.019 0.00075	0.000 0.0000	-0.025 -0.0010	0.019 0.00075	0.019 0.00075
80.000 3.1496	120.000 4.7244	0.000 0.0000	-0.030 -0.0012	0.023 0.0009	0.023 0.0009	0.000 0.0000	-0.030 -0.0012	0.023 0.0009	0.023 0.0009
120.000 4.7244	120.000 4.7244	0.000 0.0000	-0.035 -0.0014	0.026 0.0010	0.026 0.0010	0.000 0.0000	-0.035 -0.0014	0.026 0.0010	0.026 0.0010
120.000 4.7244	180.000 7.0866	0.000 0.0000	-0.040 -0.0016	0.030 0.0012	0.030 0.0012	0.000 0.0000	-0.040 -0.0016	0.030 0.0012	0.030 0.0012
180.000 7.0866	180.000 7.0866	0.000 0.0000	-0.045 -0.0018	0.034 0.0013	0.034 0.0013	0.000 0.0000	-0.045 -0.0018	0.034 0.0013	0.034 0.0013
180.000 7.0866	250.000 9.8425	0.000 0.0000	-0.050 -0.0020	0.040 0.0015	0.040 0.0015	0.000 0.0000	-0.050 -0.0020	0.040 0.0015	0.040 0.0015
250.000 9.8425	250.000 9.8425	0.000 0.0000	-0.055 -0.0022	0.045 0.0016	0.045 0.0016	0.000 0.0000	-0.055 -0.0022	0.045 0.0016	0.045 0.0016
250.000 9.8425	315.000 12.4016	0.000 0.0000	-0.060 -0.0024	0.050 0.0018	0.050 0.0018	0.000 0.0000	-0.060 -0.0024	0.050 0.0018	0.050 0.0018
315.000 12.4016	315.000 12.4016	0.000 0.0000	-0.065 -0.0026	0.055 0.0019	0.055 0.0019	0.000 0.0000	-0.065 -0.0026	0.055 0.0019	0.055 0.0019
315.000 12.4016	400.000 15.7480	0.000 0.0000	-0.070 -0.0028	0.060 0.0021	0.060 0.0021	0.000 0.0000	-0.070 -0.0028	0.060 0.0021	0.060 0.0021
400.000 15.7480	400.000 15.7480	0.000 0.0000	-0.075 -0.0030	0.065 0.0022	0.065 0.0022	0.000 0.0000	-0.075 -0.0030	0.065 0.0022	0.065 0.0022
400.000 15.7480	500.000 19.6850	0.000 0.0000	-0.080 -0.0032	0.070 0.0024	0.070 0.0024	0.000 0.0000	-0.080 -0.0032	0.070 0.0024	0.070 0.0024

Table B-51. Tolerances for outer diameter (d₁) and bore diameter (d) of series AS thrust washers

d ₁		Deviations of max. O.D. (e13)		d		Deviations of min. bore diameter (E13)	
>	≤	Max.	Min.	>	≤	Max.	Min.
mm in	mm in	mm in	mm in	mm in	mm in	mm in	mm in
18.000 0.7087	30.000 1.1811	-0.040 -0.0016	-0.370 -0.0146	3.000 0.1181	6.000 0.2362	+0.200 +0.0079	+0.020 +0.0008
30.000 1.1811	30.000 1.1811	-0.050 -0.0020	-0.440 -0.0173	6.000 0.2362	10.000 0.3937	+0.245 +0.0096	+0.025 +0.0010
30.000 1.1811	50.000 1.9685	-0.060 -0.0024	-0.520 -0.0205	10.000 0.3937	18.000 0.7087	+0.302 +0.0119	+0.032 +0.0013
50.000 1.9685	50.000 1.9685	-0.072 -0.0028	-0.612 -0.0241	18.000 0.7087	30.000 1.1811	+0.370 +0.0146	+0.040 +0.0016
50.000 1.9685	80.000 3.1496	-0.085 -0.0034	-0.715 -0.0282	30.000 1.1811	50.000 1.9685	+0.440 +0.0173	+0.050 +0.0020
80.000 3.1496	80.000 3.1496	-0.100 -0.0039	-0.820 -0.0323	50.000 1.9685	80.000 3.1496	+0.520 +0.0205	+0.060 +0.0024
80.000 3.1496	120.000 4.7244	-0.110 -0.0042	-0.920 -0.0364	80.000 3.1496	120.000 4.7244	+0.612 +0.0241	+0.072 +0.0028
120.000 4.7244	120.000 4.7244	-0.120 -0.0045	-1.020 -0.0405	120.000 4.7244	180.000 7.0866	+0.715 +0.0281	+0.085 +0.0034

The backup surfaces for the shaft washers WS.811 and WS.812 as well as the housing washers GS.811 and GS.812 of cylindrical roller thrust bearings must be square with the axis of the shaft. Equally important, the raceway or the surface backing the thrust washer must not be dished or coned. The permissible limits of the squareness and dishing or coning are shown in figures below. When using the thin (AS) thrust washers the cylindrical rollers of the thrust cage assembly must be supported over their entire length.

Table B-52. AR Series thickness and axial run-out tolerances

	Bore Dc1 mm	Thickness Tolerance μm	Axial run-out μm	
Roller thrust bearings (thin)	≤ 60	+30 / -40 ¹⁾	20 ¹⁾	Quality HP HSP
	60 < Dc1 ≤ 90	+50 / -60 ²⁾	25 ²⁾	
	90 < Dc1 ≤ 120	+50 / -60 ²⁾	30 ²⁾	
Roller thrust bearings (thick)	Dc1 ≤ 60	+30 / -30 ¹⁾	20 ¹⁾	Quality HP HSP
	60 < Dc1 ≤ 90	+50 / -50 ²⁾	25 ²⁾	
	90 < Dc1 ≤ 120	+50 / -50 ²⁾	30 ²⁾	
Thrust washers (thin) [thick]	Dc1 ≤ 120	+50 / -60[-50]	5*	2 1
	120 < Dc1 ≤ 180	+50 / -110[-100]	7*	3 1.5
	180 < Dc1 ≤ 250	+50 / -160[-150]	10*	4 2

* High precision quality. ¹⁾ Under min. load of 150 N. ²⁾ Under min. load of 250 N.

Table B-53. Tolerances for outer diameter (d₁) and bore diameter (d) of series LS heavy thrust washers

d ₁		Deviations of max. O.D. (a12)		d		Deviations of min. bore diameter (E12)	
>	≤	Max.	Min.	>	≤	Max.	Min.
mm in	mm in	mm in	mm in	mm in	mm in	mm in	mm in
18.000 0.7087	30.000 1.1811	-0.300 -0.0118	-0.510 -0.0201	3.000 0.1181	6.000 0.2362	+0.140 +0.0055	+0.020 +0.0008
30.000 1.1811	30.000 1.1811	-0.310 -0.0122	-0.560 -0.0221	6.000 0.2362	10.000 0.3937	+0.175 +0.0069	+0.025 +0.0010
30.000 1.1811	50.000 1.9685	-0.320 -0.0126	-0.570 -0.0224	10.000 0.3937	18.000 0.7087	+0.212 +0.0084	+0.032 +0.0013
50.000 1.9							

THRUST CYLINDRICAL ROLLER AND CAGE ASSEMBLIES, THRUST WASHERS

METRIC SERIES

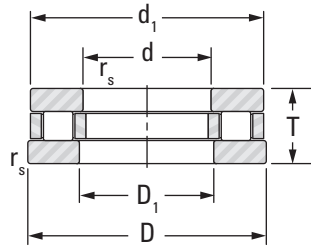

811, 812

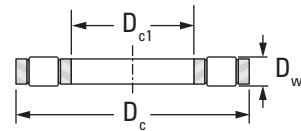

K.811, K.812

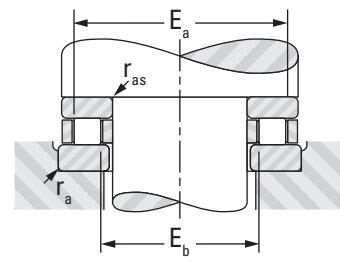

Raceway contact dimensions

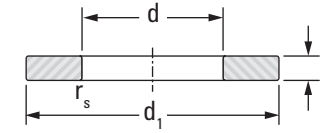

WS.811, WS.812

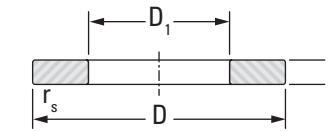

GS.811, GS.812

Shaft Dia. mm	D_{c1} mm	D_c mm	D_w mm	T mm	E_b max mm	E_a min mm	r_{as} max r_a max mm	Assembly Designation	Load Ratings		Speed Rating Oil min ⁻¹	Wt. kg lbs								
									Assembly Dimensions								Dynamic kN lbf	Static kN lbf		
									(E11) mm in	(a13) mm in										
									mm	mm			mm	mm	mm	mm	mm	mm		
15	15 0.5906	28 1.1024	3.5 0.1378	9 0.354	18 0.709	25 0.984	0.3 0.012	K.81102LPB	12.8 2880	28.6 6430	12000	0.006 0.013								
	15 0.5906	28 1.1024	3.5 0.1378	9 0.354	18 0.709	25 0.984	0.3 0.012	K.81102TVP	12.8 2880	28.6 6430	12000	0.006 0.013								
17	17 0.6693	30 1.1811	3.5 0.1378	-	20 0.787	27 1.063	0.3 0.012	K.81103LPB	14.2 3190	33.4 7510	11000	0.008 0.018								
	17 0.6693	30 1.1811	3.5 0.1378	9 0.354	20 0.787	27 1.063	0.3 0.012	K.81103TVP	14.2 3190	33.4 7510	11000	0.008 0.018								
20	20 0.7874	35 1.3780	4.5 0.1772	10 0.394	23 0.906	32 1.260	0.3 0.012	K.81104TVP	23.6 5310	56.8 12800	9500	0.009 0.020								
25	25 0.9843	42 1.6535	5.0 0.1969	11 0.433	28 1.102	39 1.535	0.6 0.024	K.81105TVP	31.2 7010	81.0 18200	8000	0.014 0.031								
30	30 1.1811	47 1.8504	5.0 0.1969	-	33 1.299	44 1.732	0.6 0.024	K.81106LPB	33.0 7420	91.1 20500	6700	0.026 0.057								
	30 1.1811	47 1.8504	5.0 0.1969	11 0.433	33 1.299	44 1.732	0.6 0.024	K.81106TVP	33.0 7420	91.1 20500	6700	0.016 0.035								
	30 1.1811	52 2.0472	7.5 0.2953	-	33 1.299	49 1.929	0.6 0.024	K.81206LPB	56.9 12800	141 31700	6300	0.052 0.115								
	30 1.1811	52 2.0472	7.5 0.2953	16 0.630	33 1.299	49 1.929	0.6 0.024	K.81206TVP	56.9 12800	141 31700	6300	0.034 0.075								
35	35 1.3780	52 2.0472	5.0 0.1969	-	38 1.496	49 1.929	0.6 0.024	K.81107LPB	34.8 7820	101 22700	6000	0.025 0.055								
	35 1.3780	52 2.0472	5.0 0.1969	12 0.472	38 1.496	49 1.929	0.6 0.024	K.81107TVP	34.8 7820	101 22700	6000	0.020 0.044								
	35 1.3780	62 2.4409	7.5 0.2953	-	41 1.614	56 2.205	1.0 0.039	K.81207LPB	61.6 13800	164 36900	5300	0.073 0.161								
	35 1.3780	62 2.4409	7.5 0.2953	18 0.709	41 1.614	56 2.205	1.0 0.039	K.81207TVP	61.6 13800	164 36900	5300	0.055 0.121								
40	40 1.5748	60 2.3622	6.0 0.2362	-	44 1.732	56 2.205	0.6 0.024	K.81108LPB	49.8 11200	148 33300	5300	0.044 0.097								
	40 1.5748	60 2.3622	6.0 0.2362	13 0.512	44 1.732	56 2.205	0.6 0.024	K.81108TVP	49.8 11200	148 33300	5300	0.031 0.068								
	40 1.5748	68 2.6772	9.0 0.3543	19 0.748	45 1.772	63 2.480	1.0 0.039	K.81208TVP	86.8 19500	233 52400	4800	0.076 0.168								
45	45 1.7717	65 2.5591	6.0 0.2362	-	49 1.929	61 2.402	0.6 0.024	K.81109LPB	52.3 11800	163 36600	4800	0.035 0.077								
	45 1.7717	65 2.5591	6.0 0.2362	14 0.551	49 1.929	61 2.402	0.6 0.024	K.81109TVP	52.3 11800	163 36600	4800	0.035 0.077								
	45 1.7717	73 2.8740	9.0 0.3543	-	50 1.969	68 2.677	1.0 0.039	K.81209TVP	94.2 21200	266 59800	4500	0.083 0.183								

d mm in	D_1 mm in	D, d_1 mm in	h		r_s min mm in	Washer Designation		Wt. kg lbs	Shaft Dia. mm
			Washer Dimensions			Shaft Piloted	Housing Piloted		
			Max.	Min.					
			mm in	mm in		mm in	mm in		
15 0.591	16 0.630	28 1.102	2.75 0.108	2.64 0.104	0.3 0.012	WS.81102	GS.81102	0.010 0.022	15
15 0.591	16 0.630	28 1.102	2.75 0.108	2.64 0.104	0.3 0.012	WS.81102	GS.81102	0.010 0.022	15
17 0.669	18 0.709	30 1.181	2.75 0.108	2.64 0.104	0.3 0.012	WS.81103	GS.81103	0.011 0.024	17
17 0.669	18 0.709	30 1.181	2.75 0.108	2.64 0.104	0.3 0.012	WS.81103	GS.81103	0.011 0.024	17
20 0.787	21 0.827	35 1.378	2.75 0.108	2.62 0.103	0.3 0.012	WS.81104	GS.81104	0.014 0.031	20
25 0.984	26 1.024	42 1.654	3.00 0.118	2.87 0.113	0.6 0.024	WS.81105	GS.81105	0.021 0.046	25
30 1.181	32 1.260	47 1.850	3.00 0.118	2.87 0.113	0.6 0.024	WS.81106	GS.81106	0.023 0.051	30
30 1.181	32 1.260	47 1.850	3.00 0.118	2.87 0.113	0.6 0.024	WS.81106	GS.81106	0.023 0.051	30
30 1.181	32 1.260	52 2.047	4.25 0.167	4.12 0.162	0.6 0.024	WS.81206	GS.81206	0.047 0.104	
30 1.181	32 1.260	52 2.047	4.25 0.167	4.12 0.162	0.6 0.024	WS.81206	GS.81206	0.047 0.104	
35 1.378	37 1.457	52 2.047	3.50 0.138	3.34 0.131	0.6 0.024	WS.81107	GS.81107	0.032 0.071	35
35 1.378	37 1.457	52 2.047	3.50 0.138	3.34 0.131	0.6 0.024	WS.81107	GS.81107	0.032 0.071	35
35 1.378	37 1.457	62 2.441	5.25 0.207	5.09 0.200	1.0 0.039	WS.81207	GS.81207	0.085 0.187	
35 1.378	37 1.457	62 2.441	5.25 0.207	5.09 0.200	1.0 0.039	WS.81207	GS.81207	0.085 0.187	
40 1.575	42 1.654	60 2.362	3.50 0.138	3.34 0.131	0.6 0.024	WS.81108	GS.81108	0.043 0.095	40
40 1.575	42 1.654	60 2.362	3.50 0.138	3.34 0.131	0.6 0.024	WS.81108	GS.81108	0.043 0.095	40
40 1.575	42 1.654	68 2.677	5.00 0.197	4.84 0.191	1.0 0.039	WS.81208	GS.81208	0.093 0.205	
45 1.772	47 1.850	65 2.559	4.00 0.157	3.84 0.151	0.6 0.024	WS.81109	GS.81109	0.054 0.119	45
45 1.772	47 1.850	65 2.559	4.00 0.157	3.84 0.151	0.6 0.024	WS.81109	GS.81109	0.054 0.119	45
45 1.772	47 1.850	73 2.874	5.50 0.217	5.34 0.210	1.0 0.039	WS.81209	GS.81209	0.112 0.247	

Continued on next page.

THRUST CYLINDRICAL ROLLER AND CAGE ASSEMBLIES, THRUST WASHERS – continued

METRIC SERIES

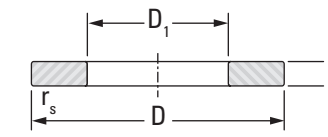
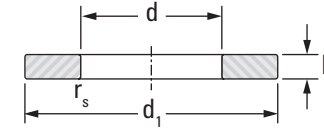
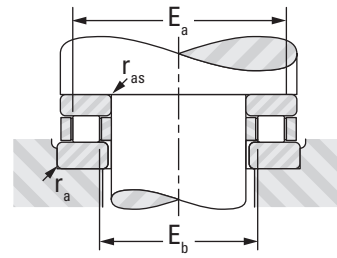
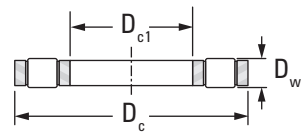
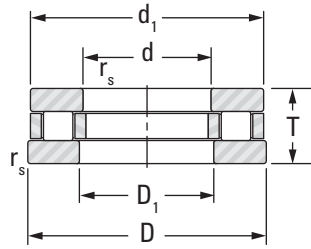

811, 812

K.811, K.812

Raceway contact dimensions

WS.811, WS.812

GS.811, GS.812

Shaft Dia.	Dc1	Dc	Dw	T	Eb max	Ea min	ras max ra max	Assembly Designation	Load Ratings		Speed Rating Oil	Wt.	
									C	Co			
	Assembly Dimensions								Dynamic	Static	min ⁻¹	kg lbs	
	(E11)	(a13)							kN lbf				
50	50	70	6.0	14	54	66	0.6	K.81110LPB	54.8	177	4300	0.052	
	1.9685	2.7559	0.2362	0.551	2.126	2.598	0.024		12300	39800			0.115
	50	70	6.0	14	54	66	0.6	K.81110TVP	54.8	177	4300	0.042	
	1.9685	2.7559	0.2362	0.551	2.126	2.598	0.024		12300	39800			0.093
	50	78	9.0	22	55	73	1.0	K.81210TVP	101	299	4000	0.089	
	1.9685	3.0709	0.3543	0.866	2.165	2.874	0.039		22700	67200			0.196
55	55	78	6.0	16	60	73	0.6	K.81111TVP	60.3	207	4000	0.066	
	2.1654	3.0709	0.2362	0.630	2.362	2.874	0.024		13600	46500			0.146
	55	90	11.0	-	61	84	1.0		K.81211LPB	138			403
2.1654	3.5433	0.4331	-	2.402	3.307	0.039	31000	90600		0.344			
	55	90	11.0	25	61	84	1.0	K.81211TVP	138	403	3600	0.140	
	2.1654	3.5433	0.4331	0.984	2.402	3.307	0.039		31000	90600			0.309
	60	85	7.5	17	65	80	1.0		K.81112TVP	84.4			281
2.3622	3.3465	0.2953	0.669	2.559	3.150	0.039	19000	63200		0.227			
	60	95	11.0	26	66	89	1.0	K.81212LPB	129	378	3400	0.166	
	2.3622	3.7402	0.4331	1.024	2.598	3.504	0.039		29000	85000			0.366
	65	90	7.5	18	70	85	1.0		K.81113TVP	88.3			305
2.5591	3.5433	0.2953	0.709	2.756	3.346	0.039	19900	68600		0.240			
	65	100	11.0	27	71	94	1.0	K.81213LPB	134	403	3200	0.176	
	2.5591	3.9370	0.4331	1.063	2.795	3.701	0.039		30100	90600			0.388
70	70	95	7.5	18	75	90	1.0	K.81114TVP	92.1	328	3200	0.056	
	2.7559	3.7402	0.2953	0.709	2.953	3.543	0.039		20700	73700			0.123
	70	105	11.0	27	76	99	1.0		K.81214LPB	138			428
2.7559	4.1339	0.4331	1.063	2.992	3.898	0.039	31000	96200		0.410			
75	75	100	7.5	19	80	95	1.0	K.81115LPB	86.1	305	3000	0.091	
	2.9528	3.9370	0.2953	0.748	3.150	3.740	0.039		19400	68600			0.201
	75	110	11.0	27	81	104	1.0	K.81215LPB	143	453	2800	0.197	
	2.9528	4.3307	0.4331	1.063	3.189	4.094	0.039		32100	101800			0.434
80	80	105	7.5	19	85	100	1.0	K.81116LPB	87.5	316	2800	0.103	
	3.1496	4.1339	0.2953	0.748	3.346	3.937	0.039		19700	71000			0.227
	80	115	11.0	28	86	109	1.0	K.81216LPB	147	478	2600	0.208	
	3.1496	4.5276	0.4331	1.102	3.386	4.291	0.039		33000	107500			0.459
85	85	110	7.5	19	90	105	1.0	K.81117LPB	88.9	328	2600	0.108	
	3.3465	4.3307	0.2953	0.748	3.543	4.134	0.039		20000	73700			0.238
	85	125	12.0	31	93	117	1.0	K.81217LPB	174	572	2400	0.376	
	3.3465	4.9213	0.4724	1.220	3.661	4.606	0.039		39100	128600			0.829
90	90	120	9.0	22	96	114	1.0	K.81118LPB	119	432	2400	0.156	
	3.5433	4.7244	0.3543	0.866	3.780	4.488	0.039		26800	97100			0.344
	90	135	14.0	35	98	127	1.0		K.81218LPB	215			691
3.5433	5.3150	0.5512	1.378	3.858	5.000	0.039	48300	155300		1.190			

d	D1	D, d1	h		rs min	Washer Designation		Wt.	Shaft Dia.
			Washer Dimensions			kg lbs	mm		
			Max.	Min.					
50	52	70	4.00	3.84	0.6	WS.81110	GS.81110	0.059	50
			0.157	0.151					
	52	70	4.00	3.84	0.6	WS.81110	GS.81110	0.059	
			0.157	0.151					
	52	78	6.5	6.34	1.0	WS.81210	GS.81210	0.144	55
			0.256	0.250					
	57	78	5.00	4.81	0.6	WS.81111	GS.81111	0.094	
			0.197	0.189					
	57	90	7.00	6.81	1.0	WS.81211	GS.81211	0.219	
			0.276	0.268					
	57	90	7.00	6.81	1.0	WS.81211	GS.81211	0.219	
			0.276	0.268					
	62	85	4.75	4.56	1.0	WS.81112	GS.81112	0.106	60
			0.187	0.180					
	62	95	7.50	7.31	1.0	WS.81212	GS.81212	0.251	
			0.295	0.288					
	67	90	5.25	5.06	1.0	WS.81113	GS.81113	0.125	65
			0.207	0.199					
	67	100	8.00	7.81	1.0	WS.81213	GS.81213	0.285	
			0.315	0.307					
	72	95	5.25	5.06	1.0	WS.81114	GS.81114	0.133	70
			0.207	0.199					
	72	105	8.00	7.81	1.0	WS.81214	GS.81214	0.302	
			0.315	0.307					
	77	100	5.75	5.56	1.0	WS.81115	GS.81115	0.155	75
			0.226	0.219					
	77	110	8.00	7.81	1.0	WS.81215	GS.81215	0.319	
			0.315	0.307					
	82	105	5.75	5.56	1.0	WS.81116	GS.81116	0.165	80
			0.226	0.219					
	82	115	8.50	8.31	1.0	WS.81216	GS.81216	0.357	
			0.335	0.327					
	87	110	5.75	5.53	1.0	WS.81117	GS.81117	0.173	85
			0.226	0.218					
	88	125	9.50	9.28	1.0	WS.81217	GS.81217	0.492	
			0.374	0.365					
	92	120	6.50	6.28	1.0	WS.81118	GS.81118	0.253	90
			0.256	0.247					
	93	135	10.50	10.28	1.1	WS.81218	GS.81218	0.655	
			0.413	0.405					

NEEDLE OR ROLLER THRUST BEARINGS

METRIC SERIES

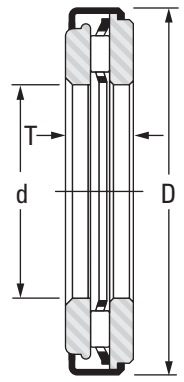

AXZ

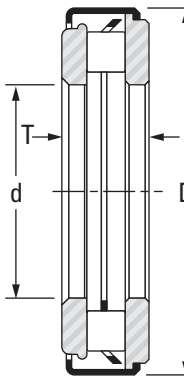

ARZ Light

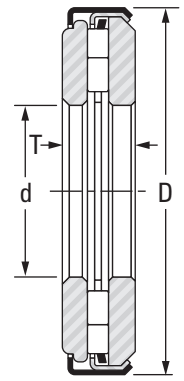

ARZ Heavy

Shaft Dia. mm	d mm in	D mm in	T mm in	Bearing Designations			Load Ratings		Speed Rating Oil min ⁻¹	Wt. kg lbs
				AXZ	ARZ Light	ARZ Heavy	C	C ₀		
							kN	lbf		
5	5 0.197	13 0.512	5.5 0.217	AXZ 5,5 5 13			3.00 670	5.70 1300	25000	0.004 0.008
6	6 0.236	14 0.551	5.5 0.217	AXZ 5,5 6 14			3.15 710	6.35 1400	22000	0.004 0.009
7	7 0.276	15 0.591	5.5 0.217	AXZ 5,5 7 15			3.55 800	7.60 1700	22000	0.005 0.010
8	8 0.315	16 0.630	5.5 0.217	AXZ 5,5 8 16			3.70 830	8.30 1900	22000	0.005 0.011
9	9 0.354	17 0.669	5.5 0.217	AXZ 5,5 9 17			4.05 910	9.50 2100	19000	0.005 0.012
10	10 0.394	22.4 0.882	6 0.236	AXZ 6 10 22,4			5.00 1120	10.9 2500	15500	0.011 0.025
	10 0.394	22.4 0.882	6.5 0.256		ARZ 6,5 10 22,4		8.20 1840	17.9 4000	15500	0.012 0.026
12	12 0.472	26.4 1.039	6 0.236	AXZ 6 12 26,4			6.90 1550	17.7 4000	13000	0.017 0.037
	12 0.472	26.4 1.039	7 0.275		ARZ 7 12 26,4		12.7 2860	29.5 6600	13000	0.017 0.037
15	15 0.591	28.4 1.118	6 0.236	AXZ 6 15 28,4			7.40 1660	20.0 4500	11500	0.016 0.034
	15 0.591	28.4 1.118	7 0.275		ARZ 7 15 28,4		14.0 3150	34.0 7600	11500	0.019 0.042
17	17 0.669	30 1.197	6 0.236	AXZ 6 17 30,4			7.80 1750	22.0 4900	10500	0.018 0.039
	17 0.669	30.4 1.197	7 0.275		ARZ 7 17 30,4		15.0 3370	39.0 8800	10500	0.022 0.049
20	20 0.787	35 1.394	8 0.315	AXZ 8 20 35,4			11.80 2650	39.0 8800	9000	0.033 0.072
	20 0.787	35.4 1.394	10 0.394		ARZ 10 20 35,4		22.0 4950	54.0 12100	9000	0.038 0.084
25	25 0.984	43 1.693	8 0.315	AXZ 8 25 43			13.30 2990	49.0 11000	7500	0.047 0.104
	25 0.984	43 1.693	10 0.394		ARZ 10 25 43		25.5 5730	70.0 15700	7500	0.057 0.126
	25 0.984	53 2.087	11 0.433		ARZ 11 25 53		32.5 7310	122 27400	6500	0.122 0.269
30	30 1.181	48 1.890	8 0.315	AXZ 8 30 48			14.50 3260	57.0 12800	6500	0.054 0.119
	30 1.181	48 1.890	10 0.394		ARZ 10 30 48		26.5 5960	77.0 17300	6500	0.065 0.143
	30 1.181	61 2.402	14 0.551		ARZ 14 30 61		46.0 10340	162 36400	5600	0.196 0.432

Continued on next page.

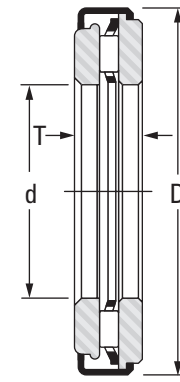

AXZ

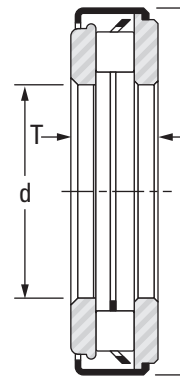

ARZ Light

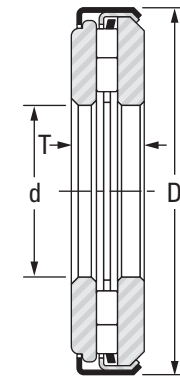

ARZ Heavy

Shaft Dia. mm	d mm in	D mm in	T mm in	Bearing Designations			Load Ratings		Speed Rating Oil min ⁻¹	Wt. kg lbs
				AXZ	ARZ Light	ARZ Heavy	C	C ₀		
							kN	lbf		
35	35 1.378	54 2.126	8 0.315	AXZ 8 35 54			18.90 4250	84.0 18900	5500	0.066 0.146
	35 1.378	54 2.126	11 0.433		ARZ 11 35 54		33.8 7600	94.0 21100	5500	0.087 0.192
	35 1.378	69 2.717	14 0.551		ARZ 14 35 69		51.0 11470	194.0 43600	4900	0.246 0.542
40	40 1.575	61 2.402	8 0.315	AXZ 8 40 61			20.40 4590	96.0 21600	5000	0.084 0.185
	40 1.575	61 2.402	12 0.472		ARZ 12 40 61		46.0 10340	129 29000	5000	0.114 0.251
	40 1.575	79 3.110	17 0.669		ARZ 17 40 79		71.0 15960	265 59600	4200	0.387 0.853
45	45 1.772	66 2.598	8 0.315	AXZ 8 45 66			21.80 4900	109 24500	4500	0.092 0.203
	45 1.772	66 2.598	12 0.472		ARZ 12 45 66		49.0 11000	143 32100	4500	0.126 0.278
	45 1.772	86 3.386	22 0.866		ARZ 22 45 86		92.0 20700	340 76400	3800	0.595 1.312
50	50 1.969	71 2.795	8 0.315	AXZ 8 50 71			22.50 5100	118 26500	4000	0.100 0.220
	50 1.969	71 2.795	12 0.472		ARZ 12 50 71		51.0 11500	157 35300	4000	0.137 0.302
	50 1.969	96 3.780	22 0.866		ARZ 22 50 96		108.0 24300	430 96700	3400	0.756 1.66
55	55 2.165	106 4.173	22 0.866		ARZ 22 55 106		125.0 28100	530 119100	3100	0.917 2.022
60	60 2.362	86 3.386	10 0.394	AXZ 10 60 86			31.50 7100	193 43400	3500	0.194 0.428
	60 2.362	86 3.386	14 0.551		ARZ 14 60 86		71.0 16000	255 57300	3500	0.246 0.542
	60 2.362	111 4.370	22 0.866		ARZ 22 60 111		130.0 29200	580 130400	2900	0.977 2.15
65	65 2.559	116 4.567	22 0.866		ARZ 22 65 116		135.0 30300	620 139400	2800	1.040 2.29
70	70 2.756	96 3.780	10 0.394	AXZ 10 70 96			34.50 7800	223 50100	3000	0.220 0.485
	70 2.756	96 3.780	14 0.551		ARZ 14 70 96		77.0 17300	295 66300	3000	0.279 0.615
80	80 3.150	106 4.173	10 0.394	AXZ 10 80 106			36.50 8200	253 56900	2700	0.256 0.564
	80 3.150	106 4.173	14 0.551		ARZ 14 80 106		82.0 18400	330 74200	2700	0.312 0.688

UNITIZED ROLLER THRUST BEARING ASSEMBLIES

METRIC SERIES

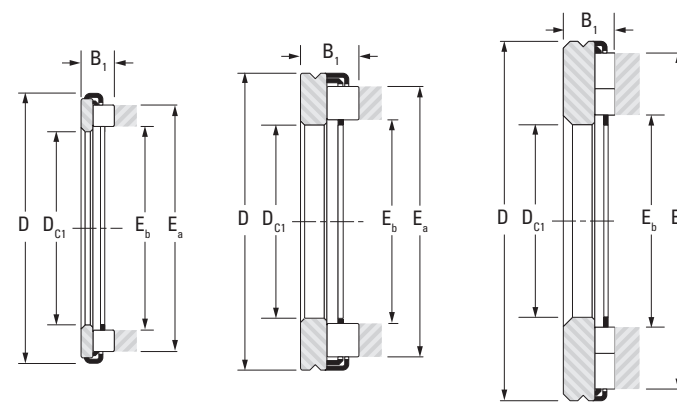

AR Light

AR Heavy

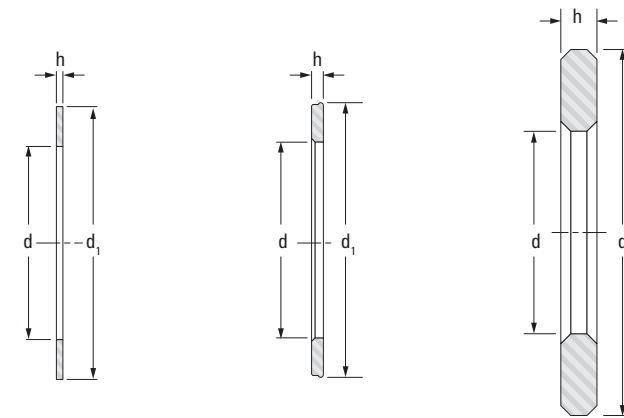

CP Thin

CP Thick

CPR Heavy

Shaft Dia.	D _{c1}	D	B ₁	E _a	E _b	AR		Wt.	C		Speed Rating Oil
						Assembly Designation			Load Ratings		
	Assembly Dimensions						Light Series	Heavy Series	Dynamic	Static	
	mm	mm in	mm in	mm in	mm in	mm in	mm in	mm in	kg lbs	kN lbf	min ⁻¹
10	10 0.394	22 0.866	4.5 0.177	18.5 0.73	12.2 0.48	AR 4,5 10 22		0.007 0.016	8.2 1840	17.9 4020	15500
12	12 0.472	26 1.024	5 0.197	22.9 0.90	14.8 0.58	AR 5 12 26		0.011 0.024	12.7 2860	29.5 6630	13000
15	15 0.591	28 1.103	5 0.197	24.9 0.98	16.8 0.66	AR 5 15 28		0.011 0.024	14.0 3150	34.0 7640	11500
17	17 0.669	30 1.181	5 0.197	26.9 1.06	18.8 0.74	AR 5 17 30		0.013 0.028	15.0 3370	39.0 8770	10500
20	20 0.787	35 1.378	7 0.276	31.6 1.24	22.0 0.87	AR 7 20 35		0.022 0.049	22.0 4950	54.0 12100	9000
25	25 0.984	42 1.654	7 0.276	37.3 1.47	27.7 1.09	AR 7 25 42		0.031 0.068	25.5 5730	70.0 15700	7500
	25 0.984	52 2.047	7 0.276	47.0 1.85	29.0 1.14		AR 7 25 52	0.070 0.154	32.5 7310	122.0 27400	6500
30	30 1.181	47 1.851	7 0.276	42.3 1.67	32.7 1.29	AR 7 30 47		0.036 0.079	26.5 5960	77.0 17300	6500
	30 1.181	60 2.362	9 0.354	53.5 2.11	33.5 1.32		AR 9 30 60	0.113 0.249	46.0 10340	162.0 36400	5600
35	35 1.378	53 2.103	8 0.315	47.8 1.88	37.8 1.49	AR 8 35 53,4		0.052 0.115	33.8 7600	94.0 21100	5500
	35 1.378	68 2.677	9 0.354	60.6 2.39	39.0 1.54		AR 9 35 68	0.144 0.317	51.0 11500	194.0 43600	4900
40	40 1.575	60 2.378	9 0.354	54.8 2.16	42.8 1.69	AR 9 40 60,4		0.070 0.154	46.0 10300	129.0 29000	5000
	40 1.575	78 3.071	11 0.433	70.0 2.76	44.0 1.73		AR 11 40 78	0.225 0.496	71.0 16000	265.0 59600	4200
45	45 1.772	65 2.575	9 0.354	59.8 2.35	47.8 1.88	AR 9 45 65,4		0.077 0.170	49.0 11000	143.0 32100	4500
	45 1.772	85 3.347	14 0.551	77.0 3.03	49.0 1.93		AR 14 45 85	0.350 0.772	92.0 20700	340.0 76400	3800
50	50 1.968	70 2.772	9 0.354	64.8 2.55	52.8 2.08	AR 9 50 70,4		0.082 0.181	51.0 11500	157.0 35300	4000
	50 1.968	95 3.740	14 0.551	86.0 3.39	54.0 2.13		AR 14 50 95	0.448 0.988	108.0 24300	430.0 96700	3400
55	55 2.165	78 3.087	10 0.394	72.5 2.85	58.5 2.30	AR 10 55 78,4		0.125 0.276	61.0 13700	203.0 45600	3800
	55 2.165	105 4.134	14 0.551	96.2 3.79	60.2 2.37		AR 14 55 105	0.537 1.184	125.0 28100	530.0 119100	3100

d	d ₁	Thin Series	h	Wt.	Thick Series	h	Wt.	Heavy Series	h	Wt.	Shaft Dia.
mm in	mm in		mm in	kg lbs		mm in	kg lbs		mm in	kg lbs	mm
10 0.396	22 0.846	CP 10 22	0.8 0.031	0.004 0.009	CP 2 10 22	2 0.079	0.002 0.004				10
12 0.474	25 1.003	CP 12 26	0.8 0.031	0.003 0.006	CP 2 12 26	2 0.079	0.006 0.014				12
15 0.593	27 1.081	CP 15 28	0.8 0.031	0.003 0.006	CP 2 15 28	2 0.079	0.006 0.013				15
17 0.671	29 1.160	CP 17 30	0.8 0.031	0.003 0.006	CP 2 17 30	2 0.079	0.007 0.015				17
20 0.789	34 1.357	CP 20 35	0.8 0.031	0.004 0.008	CP 3 20 35	3 0.118	0.013 0.029				20
25 0.988	42 1.634	CP 25 42	0.8 0.031	0.005 0.012	CP 3 25 42	3 0.118	0.019 0.042				25
25 0.992	52 2.045							CPR 4 25 52	4 0.157	0.052 0.115	25
30 1.183	46 1.830	CP 30 47	0.8 0.031	0.006 0.013	CP 3 30 47	3 0.118	0.022 0.049				30
30 1.189	60 2.360							CPR 5 30 60	5 0.197	0.083 0.183	
35 1.380	51 2.026	CP 35 52	0.8 0.031	0.007 0.015	CP 3 35 52	3 0.118	0.026 0.057				35
35 1.386	68 2.675							CPR 5 35 68	5 0.197	0.102 0.225	
40 1.577	59 2.341	CP 40 60	0.8 0.031	0.009 0.021	CP 3 40 60	3 0.118	0.034 0.075				40
40 1.583	78 3.069							CPR 6 40 78	6 0.236	0.162 0.357	
45 1.774	64 2.533	CP 45 65	0.8 0.031	0.010 0.022	CP 3 45 65	3 0.118	0.037 0.082				45
45 1.780	85 3.344							CPR 8 45 85	8 0.315	0.245 0.540	
50 1.970	69 2.731	CP 50 70	0.8 0.031	0.011 0.024	CP 3 50 70	3 0.118	0.040 0.088				50
50 1.970	95 2.731		0.031	0.024		0.118	0.088	CPR 8 50 95	8 0.315	0.308 0.679	
55 2.167	77 3.046	CP 55 78	0.8 0.031	0.014 0.031	CP 4 55 78	4 0.157	0.069 0.152				55
55 2.174	105 4.131							CPR 8 55 105	8 0.315	0.380 0.838	

Continued on next page.

UNITIZED ROLLER
THRUST BEARING ASSEMBLIES — continued
METRIC SERIES

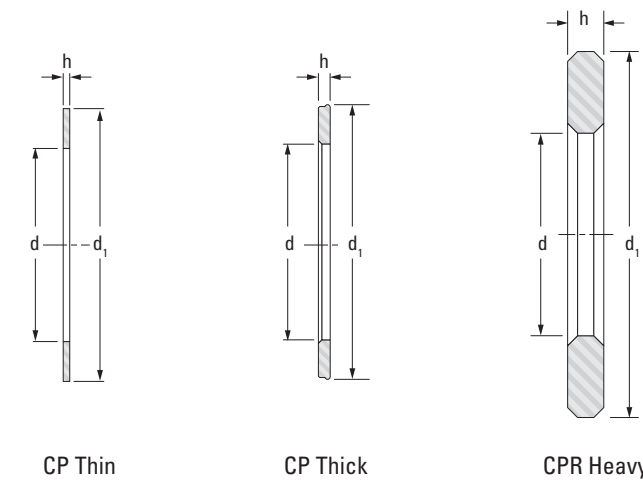
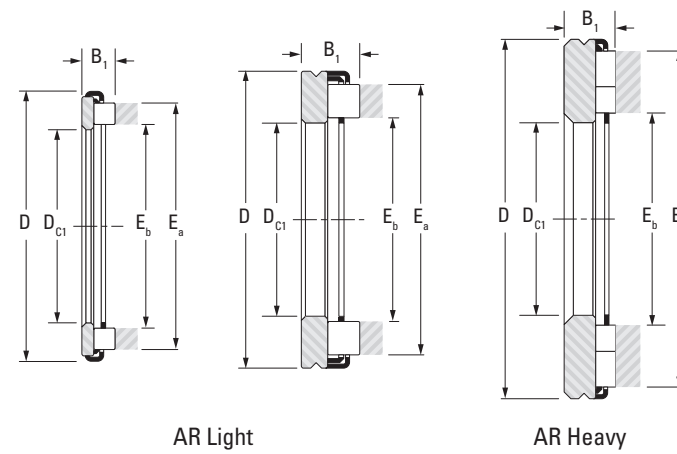

Shaft Dia.	D _{c1}	D	B ₁	E _a	E _b	AR		Wt.	C		Speed Rating Oil
						Assembly Designation			Load Ratings		
						Light Series	Heavy Series		Dynamic	Static	
mm	mm in	mm in	mm in	mm in	mm in		kg lbs	kN lbf		min ⁻¹	
60	60	85	10	79.5	63.5	AR 10 60 85,4		0.150	71.0	255.0	3500
	2.362	3.362	0.394	3.13	2.50						
65	60	110	14	101.2	65.2	AR 14 60 110		0.572	130.0	580.0	2900
	2.362	4.331	0.551	3.98	2.57						
65	65	90	10	84.5	68.5	AR 10 65 90,4		0.160	74.0	275.0	3200
	2.559	3.559	0.394	3.33	2.70						
70	65	115	14	106.2	70.2	AR 14 65 115		0.610	135.0	620.0	2800
	2.559	4.528	0.551	4.18	2.76						
70	70	95	10	89.5	73.5	AR 10 70 95,4		0.170	77.0	295.0	3000
	2.756	3.756	0.394	3.52	2.89						
75	70	125	16	116.0	76.0	AR 16 70 125		0.775	174.0	710.0	2600
	2.756	4.921	0.630	4.57	2.99						
75	75	100	10	94.5	78.5	AR 10 75 100,4		0.180	80.0	313.0	2800
	2.953	3.938	0.394	3.72	3.09						
80	75	135	16	126.0	82.0	AR 16 75 135		0.893	198.0	860.0	2400
	2.953	5.315	0.630	4.96	3.23						
80	80	105	10	99.5	83.5	AR 10 80 105,4		0.190	82.0	330.0	2700
	3.150	4.150	0.394	3.92	3.29						
85	80	140	16	131.0	87.0	AR 16 80 140		0.960	208.0	940.0	2300
	3.150	5.512	0.630	5.16	3.43						
90	85	150	18	138.0	92.0	AR 18 85 150		1.256	230.0	1010.0	2100
	3.346	5.906	0.709	5.43	3.62						
90	90	155	18	143.0	97.0	AR 18 90 155		1.330	245.0	1090.0	2000
	3.550	6.103	0.709	5.63	3.82						
100	100	170	20	157.0	109.0	AR 20 100 170		1.740	280.0	1250.0	1800
	3.937	6.693	0.787	6.18	4.29						
110	110	190	24	178.0	118.0	AR 24 110 190		2.500	365.0	1600.0	1700
	4.331	7.481	0.945	7.01	4.65						
120	120	210	24	199.0	127.0	AR 24 120 210		3.200	470.0	2300.0	1500
	4.724	8.268	0.945	7.83	5.00						
130	130	225	24	214.0	138.0	AR 24 130 225		3.600	510.0	2640.0	1400
	5.118	8.858	0.945	8.43	5.43						
140	140	240	28	229.0	149.0	AR 28 140 240		4.800	600.0	2980.0	1300
	5.511	9.449	1.102	9.02	5.87						

d	d ₁	Thin Series	h	Wt.	Thick Series	h	Wt.	Heavy Series	h	Wt.	Shaft Dia.
mm in	mm in		mm in	kg lbs		mm in	kg lbs		mm in	kg lbs	mm
60	84	CP 60 85	0.8	0.017	CP 4 60 85	4	0.083				60
2.366	3.318										
60	110	CP 1,5 65 90	1.5	0.033	CP 4 65 90	4	0.088	CPR 8 60 110	8	0.405	
2.371	4.328										
65	89	CP 1,5 65 90	1.5	0.033	CP 4 65 90	4	0.088				65
2.563	3.515										
65	115	CPR 8 65 115	8	0.430							
2.568	4.525										
70	94	CP 1,5 70 95	1.5	0.034	CP 4 70 95	4	0.093				70
2.760	3.711										
70	125	CPR 8 70 125	8	0.510							
2.765	4.918										
75	99	CP 1,5 75 100	1.5	0.037	CP 4 75 100	4	0.099				75
2.967	3.894										
75	135	CPR 8 75 135	8	0.595							
2.961	5.312										
80	104	CP 1,5 80 105	1.5	0.039	CP 4 80 105	4	0.104				80
3.163	4.091										
80	140	CPR 8 80 140	8	0.630							
3.159	5.508										
85	150	CPR 9 85 150	9	0.815							85
3.356	5.902										
90	155	CPR 9 90 155	9	0.840							90
3.553	6.099										
100	170	CPR 10 100 170	10	1.13							100
3.946	6.690										
110	190	CPR 12 110 190	12	1.70							110
4.340	7.476										
120	210	CPR 12 120 210	12	2.10							120
4.735	8.264										
130	225	CPR 12 130 225	12	2.40							130
5.128	8.854										
140	240	CPR 14 140 240	14	3.20							140

THRUST ASSEMBLIES AND THRUST BEARINGS – INCH SERIES

Thrust assemblies and thrust bearings of inch series are available in a variety of sizes. This catalog includes the most popular, standardized designs. If the backup surfaces cannot be used as raceways, hardened thrust washers are available.

REFERENCE STANDARDS ARE:

- **ANSI/ABMA Std. 21.2** – thrust needle roller and cage assemblies and thrust washers – inch design.
- **ANSI/ABMA Std. 24.2** – thrust bearings of ball and cylindrical roller types – inch design.

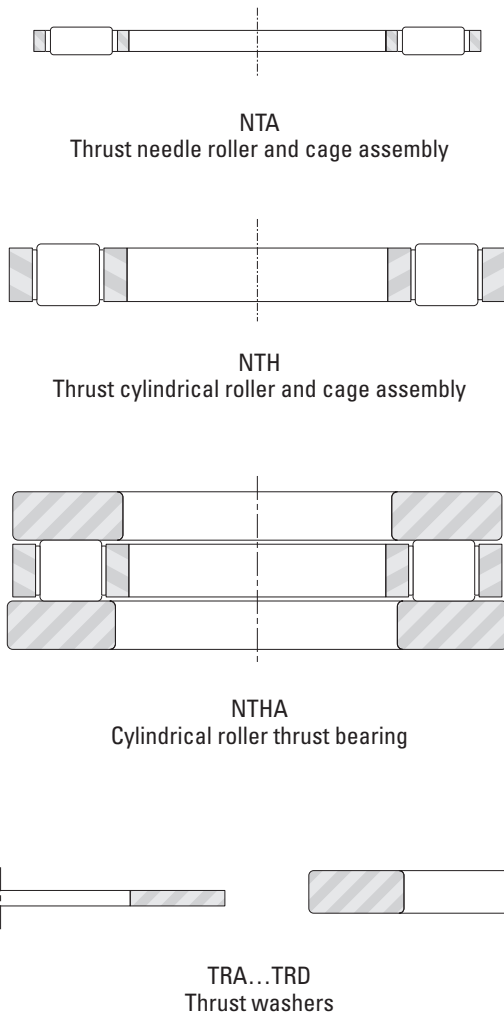

Fig. B-75. Types of inch series thrust assemblies, thrust bearings and thrust washers

IDENTIFICATION

NTA is the complete prefix code for a thrust needle roller and cage assembly with inch nominal dimensions using needle rollers of the smallest practical diameter.

Thrust cylindrical roller and cage assemblies with inch nominal dimensions are identified by the prefix letters NTH. They use large diameter cylindrical rollers, providing higher load ratings.

Thrust washers of inch nominal dimensions are identified by the prefix letters TR followed by another letter such as A, B or C etc. – indicating washer thickness. TRA is the complete prefix code for the thinnest thrust washer made to inch nominal dimensions.

Most thrust washers are intended to be piloted on their bores. Some washers, however, are designed to be piloted on their outer diameters. Such washers are identified by the letter D, following the thickness code letter. Thus TRJD is the complete prefix code for a thrust washer with inch nominal dimensions of J thickness and designed to be piloted by its outer diameter.

Cylindrical roller thrust bearings, with prefix code NTHA, are made up of one NTH assembly – one TRI or TRJ bore-piloted washer and one TRID or TRJD outer-diameter piloted washer.

Because the bearing designation for thrust assemblies does not appear on the bearing itself, the manufacturer's parts list or another reliable source should always be consulted when ordering bearings for service or field replacement – to make certain that the correct bearing with the correct lubricant is used.

CONSTRUCTION

Thrust needle roller and cage assemblies (NTA) and thrust cylindrical roller and cage assemblies (NTH) have hardened cages and through-hardened, precision-ground rollers. The cages are securely fastened assemblies of two mating pieces. This construction minimizes cage stress and assures that the roller retaining function of the cage is unaffected by normal wear. The needle rollers and the cylindrical rollers are precision ground and lapped to close tolerance for optimum load distribution.

Thrust washers for the thrust needle roller and cage assemblies are designed for bore piloting. The thinner thrust washers are tumble burnished and may be out-of-flat due to heat treatment – but will flatten under load. The raceway surfaces of thick thrust washers are ground and lapped.

Thrust washers for the thrust cylindrical roller and cage assemblies are available in both bore-piloted and outer-diameter piloted types. Their piloting surfaces are ground and raceway surfaces are ground and lapped.

DIMENSIONAL ACCURACY

TOLERANCES FOR THRUST NEEDLE ROLLER AND CAGE ASSEMBLIES

Pages B-312 to B-320, list the nominal outer diameter, bore diameter and the needle roller diameter for the inch thrust needle roller and cage assemblies. And their corresponding thrust washers appear in the bearing tables.

Tolerances for the bore diameters and outer diameters of inch thrust assemblies are given in Table B-55.

Table B-55. Tolerances for bore (D_{c1}) and outer (D_c) diameters of nominal inch thrust needle (NTA) and cylindrical (NTH) roller and cage assemblies

NTA thrust needle roller and cage assemblies				
D_w	Deviations			
	D_{c1}		D_c	
	Bore diameter		Outer diameter	
Needle roller diameter (nominal)	Max.	Min.	Max.	Min.
mm in	mm in	mm in	mm in	mm in
1.981 0.078	+0.178 +0.007	+0.051 +0.002	-0.254 -0.010	-0.508 -0.020
3.175 0.125	+0.254 +0.010	+0.051 +0.002	-0.254 -0.010	-0.635 -0.025
NTH thrust cylindrical roller and cage assemblies				
All diameters	+0.381 +0.015	0.000 0.000	-0.127 -0.005	-0.508 -0.020

BORE INSPECTION PROCEDURE FOR ASSEMBLY

The bore diameter (D_{c1}) of the assembly should be checked with "go" and "no go" plug gages. The "go" plug gage size is the minimum bore diameter of the assembly. The "no go" plug gage size is the maximum bore diameter of the assembly.

The assembly must fall freely from the "go" plug gage under its own free weight. The "no go" plug gage must not enter the bore. Where the "no go" plug gage can be forced through the bore, the assembly must not fall from the gage under its own weight.

TOLERANCES FOR THRUST WASHERS

Tolerances for the outer diameters and bore diameters of nominal inch thrust washers are given in Tables B-56 (1) and B-56 (2).

Table B-56 (1) . Tolerances for outer diameter (d_1) of nominal inch (TRA, TRB, etc.) thrust washers

d_1 :Nominal outer diameter				Deviations			
>		≤		Max.		Min.	
mm	in	mm	in	mm	in	mm	in
6.000	0.24	133.400	5.25	-0.025	-0.010	-0.760	-0.030

Table B-56 (2) . Tolerances for bore diameter (d) of nominal inch (TRA, TRB, etc.) thrust washers

d :Nominal bore diameter				Deviations			
>		≤		Max.		Min.	
mm	in	mm	in	mm	in	mm	in
6.000	0.24	57.200	2.25	+0.300	+0.012	+0.050	+0.002
57.200	2.25	133.400	5.25	+0.430	+0.017	+0.050	+0.002

BORE INSPECTION PROCEDURE FOR THRUST WASHER

The bore diameter (d) of the thrust washer should be checked with “go” and “no go” plug gages. The “go” plug gage size is the minimum bore diameter of the thrust washer. The “no go” plug gage size is the maximum bore diameter of the thrust washer.

The thrust washer, under its own weight, must fall freely from the “go” plug gage. The “no go” plug gage must not enter the bore. Where the “no go” plug gage can be forced through the bore, the thrust washer must not fall from the gage under its own weight.

TOLERANCES FOR CYLINDRICAL ROLLER THRUST BEARINGS

The tolerances for inch series cylindrical roller thrust bearings, cylindrical roller cage and thrust assemblies and their corresponding component thrust washers appear in the bearing tables.

MOUNTING TOLERANCES

THRUST NEEDLE ROLLER AND CAGE ASSEMBLIES

On NTA inch type thrust needle roller and cage assemblies, the cage bore has a larger contact area and a closer tolerance than the outer diameter. Therefore, bore piloting is preferred for these assemblies. To reduce wear, it is suggested that the piloting surface for the cage be hardened to an equivalent of at least 55 HRC.

Where design requirements prevent bore piloting, the NTA thrust needle roller and cage assemblies may be piloted on the outer diameters. It should be noted that the “diameter to clear washer O.D.” given in the bearing tables is not suitable for outer diameter piloting. For such cases, suitable O.D. piloting dimensions should be determined in consultation with your representative.

THRUST WASHERS FOR USE WITH NTA THRUST NEEDLE ROLLER AND CAGE ASSEMBLIES

Ideally, a thrust washer should be stationary with respect to and piloted by its supporting or backing member – whether or not this is an integral part of the shaft or housing. There should be no rubbing action between the thrust washer and any other machine member. The economics of design, however, often preclude these ideal conditions and thrust washers must be employed in another manner. In such cases, design details should be determined in consultation with your representative.

THRUST CYLINDRICAL ROLLER AND CAGE ASSEMBLIES

Type NTH assembly cage has a relatively large contact area on both the bore and the outer diameter. Thus, these assemblies can be piloted by either the shaft or the housing. In order to reduce wear, it is suggested that the piloting surface for the cage be hardened to an equivalent of at least 55 HRC.

When the shaft is used as the piloting surface the outer diameter of the cage must clear the housing under all conditions. Conversely, when the housing is the piloting surface, the shaft must clear the cage bore under all conditions. The mounting dimensions are given in the bearing tables for both shaft and housing piloting. Bore inspection procedure for the assembly given on page B-309 should be used for checking the bore of NTH assemblies.

THRUST WASHERS FOR USE WITH THRUST CYLINDRICAL ROLLER AND CAGE ASSEMBLIES

Types TRID and TRJD thrust washers for use with thrust cylindrical roller and cage assemblies are designed to pilot from the housing and to clear the shaft. Types TRI and TRJ thrust washers are designed to pilot from the shaft and clear the housing. The thrust washers should be stationary with respect to their piloting (or locating) machine members. There should be no rubbing action between the washer and any other machine member.

BACKUP SURFACES

In some applications, it is desirable to use the backup surfaces as raceways for the rollers of the thrust assemblies. When this is done, these surfaces must be hardened to an equivalent of at least 58 HRC. If this hardness cannot be achieved and thrust washers cannot be used, the load ratings must be reduced as explained in the engineering section of this catalog.

Thrust raceway surfaces must be ground to a surface of 8 µin Ra (0.20 µm Ra). When this requirement cannot be met, thrust washers must be used.

The raceways against which the rollers operate or the surfaces against which the thrust washers bear must be square with the axis of the shaft. Equally important, the raceway or surface backing the thrust washer must not be dished or coned. The permissible limits of out-of-squareness and dishing or coning are shown in the figures below.

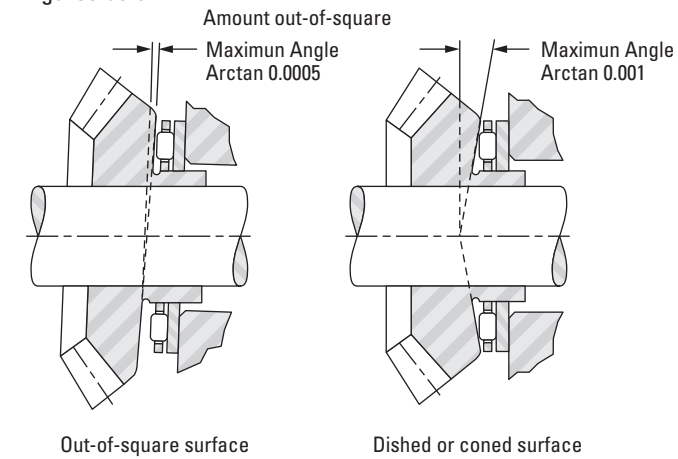

Fig. B-76. Permissible limits

TYPE NTHA CYLINDRICAL ROLLER THRUST BEARING

The NTHA cylindrical roller thrust bearing consists of the NTH thrust cylindrical roller and cage assembly and two thrust washers. This bearing is sold as a unit.

A typical mounting of the thrust bearing on a rotating shaft is shown in Fig. B-77. The bore of the rotating shaft supported thrust washer is ground for an accurate fit on the shaft. The outer diameter of the stationary housing supported thrust washer is ground for a proper fit in the housing.

The NTHA cylindrical roller thrust bearing cage is normally shaft piloted. In the event it is necessary to pilot the cage by the housing – Fig. B-78 illustrates a possible mounting arrangement. When other mounting arrangements are dictated by the application, they should be determined in consultation with your representative.

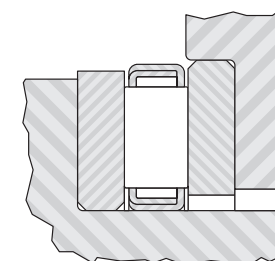

Fig. B-77. Typical mounting of a thrust bearing when the shaft rotates

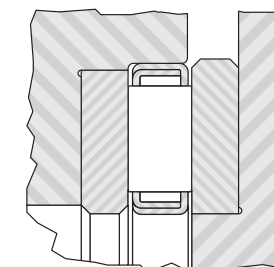

Fig. B-78. NTHA possible mounting arrangement

LOAD RATINGS

MINIMUM AXIAL LOAD

Slippage can occur if the applied axial load is too light and the operating speed of the thrust needle roller and cage assembly is high – particularly if accompanied by inadequate lubrication. For satisfactory operation, a certain minimum load must be applied to a thrust needle roller and cage assembly which can be calculated from:

$$F_{a \text{ min}} = C_0/2200 \text{ [kN]}$$

Where:

- C_0 = static load rating [kN]
- $F_{a \text{ min}}$ = minimum axial load [kN]

COEFFICIENT OF FRICTION

In general, the coefficient of friction of a thrust bearing (consisting of a thrust needle or cylindrical roller and cage assembly and thrust washers) is defined as the friction torque divided by the product of the applied load and the bearing pitch radius. This coefficient of friction is not a constant value, but will vary considerably with load, speed and lubricant. Generally, the coefficient of friction becomes smaller as the load is increased, and larger as the speed is increased. It is suggested that a value of 0.004 to 0.005 be used as a conservative estimate.

LUBRICATION

Oil is the preferred lubricant for thrust needle or cylindrical roller and cage assemblies. An ample oil flow is absolutely necessary for high speeds or for moderate speeds when the load is relatively high.

When the application must utilize grease lubrication, the thrust needle roller and cage assembly should be ordered pre-greased. When the speeds are low and rotation is not continuous, the initial charge of grease may be suitable for the life of the application. When the speeds are moderate, the designer must provide for frequent re-greasing. Because the rollers tend to expel the lubricant radially outward, re-lubrication passages should be directed to the bore of the cage, whether oil or grease is used as the lubricant.

SPECIAL DESIGNS

Thrust needle roller and cage assemblies and thrust washers are also made to special dimensions and configurations, as well as from special materials – when quantities permit economical manufacture.

Thrust needle roller and cage assemblies are particularly adaptable to low-cost integral combinations, with special thrust washers. When the use of such special designs are considered, the following pages should be reviewed for evaluation of proposed arrangements.

THRUST NEEDLE ROLLER AND CAGE ASSEMBLIES, THRUST WASHERS

INCH SERIES

- Dimensions for bore and O.D. of thrust assemblies and washers are nominal.
- See page B-310 for details on piloting and backup surfaces.
- Thrust washers burnished at least one-quarter of bore area (remainder is rough breakaway finish).
- O.D. finish of washers will be as blanked.
- Thinner washers may be out-of-flat due to distortion in hardening in the free state (expected to flatten out under load).

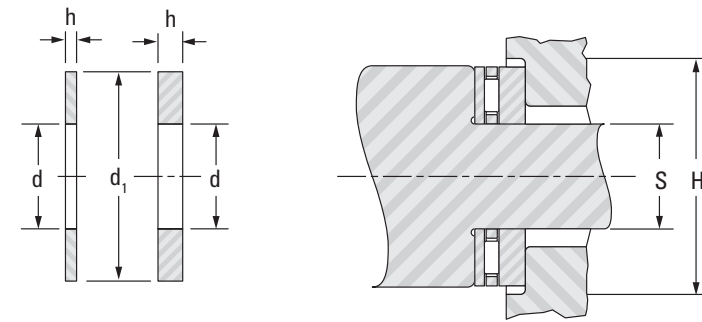
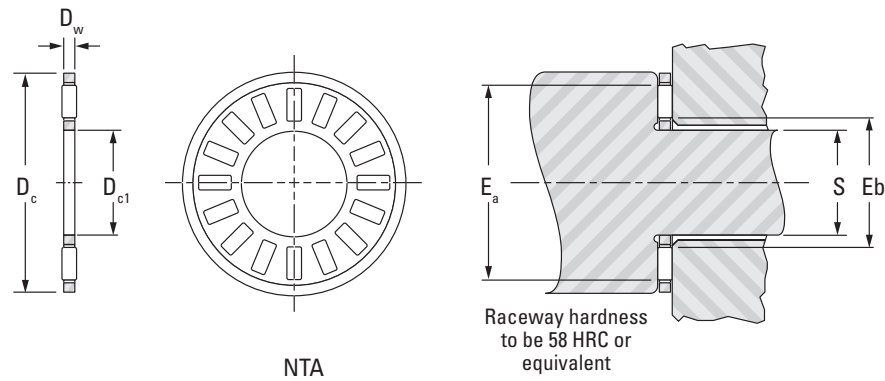

Shaft Dia.	D _{c1}	D _c	D _w	E _b	E _a	Assembly Designation	Load Ratings		Speed Rating ⁽¹⁾	Wt.
							Dynamic	Static		
							kN lbf			
1/4	6.35 0.250	17.45 0.687	1.984 0.0781	8.636 0.340	14.732 0.580	NTA-411	5.12 1150	10.76 2420	26000	0.001 0.003
5/16	7.92 0.312	19.05 0.75	1.984 0.0781	10.16 0.400	16.256 0.640	NTA-512	5.83 1310	13.17 2960	24000	0.002 0.004
3/8	9.53 0.375	20.625 0.812	1.984 0.0781	11.68 0.460	18.034 0.710	NTA-613	6.05 1360	14.32 3220	22000	0.002 0.004
1/2	12.70 0.500	23.80 0.937	1.984 0.0781	14.99 0.590	21.08 0.830	NTA-815	7.16 1610	19.13 4300	19000	0.002 0.005
9/16	14.275 0.562	25.40 1.000	1.9837 0.0781	16.51 0.650	22.606 0.890	NTA-916	7.70 1730	21.53 4840	18000	0.003 0.006
5/8	15.88 0.625	28.575 1.125	1.9837 0.0781	18.03 0.710	25.908 1.020	NTA-1018	9.79 2200	30.38 6830	15000	0.003 0.007

Thrust Washer Designation	d	d ₁	h		S		H ⁽²⁾ Dia. To Clear O.D.	Washer Wt. kg lbs	Shaft Dia. in
			Max.	Min.	Max.	Min.			
			mm in	mm in	mm in	mm in			
TRA-411	6.35 0.250	17.45 0.687	0.81 0.032	0.76 0.030	6.35 0.250	6.27 0.247	18.26 0.719	0.001 0.003	1/4
TRB-411	6.35 0.250	17.45 0.687	1.60 0.063	1.52 0.060	6.35 0.250	6.27 0.247	18.26 0.719	0.002 0.005	
TRC-411	6.35 0.250	17.45 0.687	2.41 0.095	2.34 0.092	6.35 0.250	6.27 0.247	18.26 0.719	0.004 0.008	
TRA-512	7.92 0.312	19.05 0.750	0.81 0.032	0.76 0.030	7.92 0.312	7.85 0.309	19.84 0.781	0.001 0.003	5/16
TRB-512	7.92 0.312	19.05 0.750	1.60 0.063	1.52 0.060	7.92 0.312	7.85 0.309	19.84 0.781	0.003 0.006	
TRA-613	9.53 0.375	20.62 0.812	0.81 0.032	0.76 0.030	9.53 0.375	9.45 0.372	21.44 0.844	0.001 0.003	3/8
TRB-613	9.53 0.375	20.62 0.812	1.60 0.063	1.52 0.060	9.53 0.375	9.45 0.372	21.44 0.844	0.003 0.006	
TRC-613	9.53 0.375	20.62 0.812	2.41 0.095	2.34 0.092	9.53 0.375	9.45 0.372	21.44 0.844	0.004 0.009	
TRA-815	12.70 0.500	23.80 0.937	0.81 0.032	0.76 0.030	12.70 0.500	12.62 0.497	24.61 0.969	0.002 0.004	1/2
TRB-815	12.70 0.500	23.80 0.937	1.60 0.063	1.52 0.060	12.70 0.500	12.62 0.497	24.61 0.969	0.004 0.008	
TRC-815	12.70 0.500	23.80 0.937	2.41 0.095	2.34 0.092	12.70 0.500	12.62 0.497	24.61 0.969	0.005 0.012	
TRA-916	14.27 0.562	25.40 1.000	0.81 0.032	0.76 0.030	14.27 0.562	14.20 0.559	26.19 1.031	0.002 0.005	9/16
TRB-916	14.27 0.562	25.40 1.000	1.60 0.063	1.52 0.060	14.27 0.562	14.20 0.559	26.19 1.031	0.004 0.008	
TRC-916	14.27 0.562	25.40 1.000	2.41 0.095	2.34 0.092	14.27 0.562	14.20 0.559	26.19 1.031	0.006 0.013	
TRA-1018	15.88 0.625	28.58 1.125	0.81 0.032	0.76 0.030	15.88 0.625	15.80 0.622	29.36 1.156	0.003 0.006	5/8
TRB-1018	15.88 0.625	28.58 1.125	1.60 0.063	1.52 0.060	15.88 0.625	15.80 0.622	29.36 1.156	0.005 0.012	
TRC-1018	15.88 0.625	28.58 1.125	2.41 0.095	2.34 0.092	15.88 0.625	15.80 0.622	29.36 1.156	0.008 0.018	
TRD-1018	15.88 0.625	28.58 1.125	3.20 0.126	3.12 0.123	15.88 0.625	15.80 0.622	29.36 1.156	0.011 0.024	
TRE-1018	15.88 0.625	28.58 1.125	3.99 0.157	3.91 0.154	15.88 0.625	15.80 0.622	29.36 1.156	0.013 0.029	

⁽¹⁾Speed ratings listed are based on adequate oil lubrication. See page B-311 for lubrication information. Suggestions for an application requiring O.D. piloting should be determined in consultation with your representative.

⁽²⁾If the shaft and the housing adjacent to the bearing O.D. are not concentric, the T.I.R. between the shaft and housing should be added to this dimension.

Continued on next page.

THRUST NEEDLE ROLLER AND CAGE ASSEMBLIES, THRUST WASHERS – continued

INCH SERIES

- Dimensions for bore and O.D. of thrust assemblies and washers are nominal.
- See page B-310 for details on piloting and backup surfaces.
- Thrust washers burnished at least one-quarter of bore area (remainder is rough breakaway finish).
- O.D. finish of washers will be as blanked.
- Thinner washers may be out-of-flat due to distortion in hardening in the free state (expected to flatten out under load).

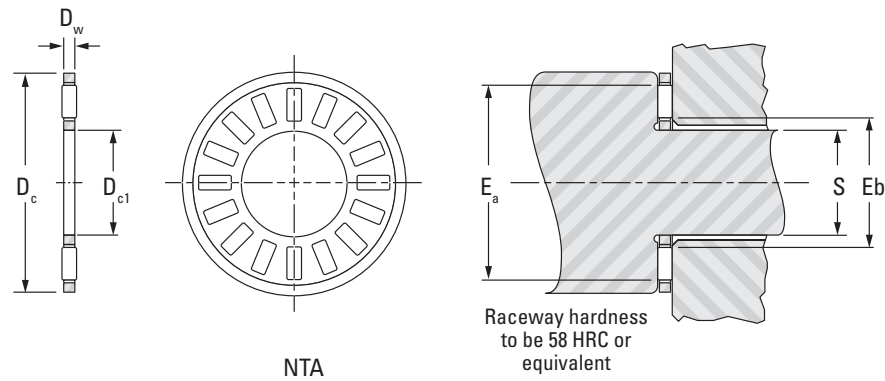

Shaft Dia.	D _{c1}	D _c	D _w	E _b	E _a	Assembly Designation	Load Ratings		Speed Rating ⁽¹⁾	Wt.
							Dynamic	Static		
							kN lbf			
in	mm in	mm in	mm in	mm in	mm in				min ⁻¹	kg lbs
3/4	19.05 0.750	31.75 1.250	1.9837 0.0781	21.34 0.840	28.956 1.140	NTA-1220	10.90 2450	36.48 8200	14000	0.004 0.009
7/8	22.23 0.875	36.50 1.437	1.984 0.0781	24.38 0.960	33.782 1.330	NTA-1423	13.43 3020	49.82 11200	12000	0.005 0.011
7/8	22.23 0.875	42.85 1.687	1.984 0.0781	25.91 1.020	39.878 1.570	NTC-1427	18.46 4150	78.29 17600	9800	0.008 0.017
1	25.40 1.000	39.675 1.562	1.984 0.0781	27.69 1.090	36.83 1.450	NTA-1625	13.83 3110	53.82 12100	11000	0.006 0.013
1 1/8	28.58 1.125	44.45 1.75	1.9837 0.0781	30.73 1.210	41.656 1.640	NTA-1828	16.68 3750	71.17 16000	9600	0.009 0.019

⁽¹⁾Speed ratings listed are based on adequate oil lubrication. See page B-311 for lubrication information. Suggestions for an application requiring O.D. piloting should be determined in consultation with your representative.

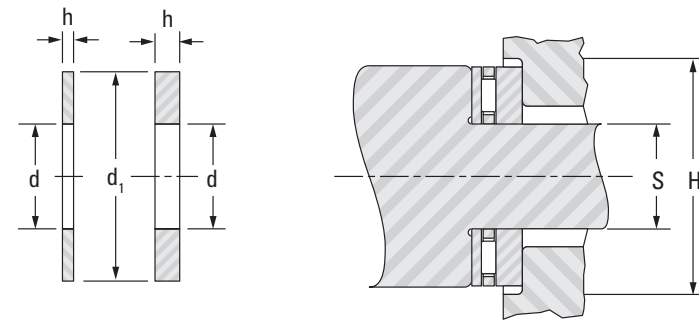

Thrust Washer Designation	d	d ₁	h		S		H ⁽²⁾ Dia. To Clear O.D.	Washer Wt. kg lbs	Shaft Dia. in
			Max.	Min.	Max.	Min.			
			mm in	mm in	mm in	mm in			
TRA-1220	19.05 0.750	31.75 1.250	0.81 0.032	0.76 0.030	19.05 0.750	18.97 0.747	32.54 1.281	0.003 0.007	3/4
TRB-1220	19.05 0.750	31.75 1.250	1.60 0.063	1.52 0.060	19.05 0.750	18.97 0.747	32.54 1.281	0.006 0.013	
TRC-1220	19.05 0.750	31.75 1.250	2.41 0.095	2.34 0.092	19.05 0.750	18.97 0.747	32.54 1.281	0.010 0.021	
TRD-1220	19.05 0.750	31.75 1.250	3.20 0.126	3.12 0.123	19.05 0.750	18.97 0.747	32.54 1.281	0.012 0.026	
TRE-1220	19.05 0.750	31.75 1.250	3.99 0.157	3.91 0.154	19.05 0.750	18.97 0.747	32.54 1.281	0.015 0.033	
TRA-1423	22.23 0.875	36.50 1.437	0.81 0.032	0.76 0.030	22.23 0.875	22.15 0.872	37.31 1.469	0.004 0.009	7/8
TRB-1423	22.23 0.875	36.50 1.437	1.60 0.063	1.52 0.060	22.23 0.875	22.15 0.872	37.31 1.469	0.008 0.017	
TRC-1423	22.23 0.875	36.50 1.437	2.41 0.095	2.34 0.092	22.23 0.875	22.15 0.872	37.31 1.469	0.012 0.026	
TRD-1423	22.23 0.875	36.50 1.437	3.20 0.126	3.12 0.123	22.23 0.875	22.15 0.872	37.31 1.469	0.015 0.034	
TRB-1427	22.23 0.875	42.86 1.688	1.60 0.063	1.52 0.060	22.23 0.875	22.15 0.872	43.66 1.719	0.013 0.029	
TRC-1427	22.23 0.875	42.86 1.688	2.41 0.095	2.34 0.092	22.23 0.875	22.15 0.872	43.66 1.719	0.020 0.044	
TRD-1427	22.23 0.875	42.86 1.688	3.20 0.126	3.12 0.123	22.23 0.875	22.15 0.872	43.66 1.719	0.026 0.057	
TRA-1625	25.40 1.000	39.67 1.562	0.81 0.032	0.76 0.030	25.40 1.000	25.32 0.997	40.49 1.594	0.005 0.010	1
TRB-1625	25.40 1.000	39.67 1.562	1.60 0.063	1.52 0.060	25.40 1.000	25.32 0.997	40.49 1.594	0.009 0.019	
TRD-1625	25.40 1.000	39.67 1.562	3.20 0.126	3.12 0.123	25.40 1.000	25.32 0.997	40.49 1.594	0.017 0.038	
TRE-1625	25.40 1.000	39.67 1.562	3.99 0.157	3.91 0.154	25.40 1.000	25.32 0.997	40.49 1.594	0.021 0.047	
TRA-1828	28.58 1.125	44.45 1.750	0.81 0.032	0.76 0.030	28.58 1.125	28.50 1.122	45.24 1.781	0.006 0.013	1 1/8
TRB-1828	28.58 1.125	44.45 1.750	1.60 0.063	1.52 0.060	28.58 1.125	28.50 1.122	45.24 1.781	0.011 0.024	
TRC-1828	28.58 1.125	44.45 1.750	2.41 0.095	2.34 0.092	28.58 1.125	28.50 1.122	45.24 1.781	0.017 0.037	

⁽²⁾If the shaft and the housing adjacent to the bearing O.D. are not concentric, the T.I.R. between the shaft and housing should be added to this dimension.

Continued on next page.

THRUST NEEDLE ROLLER AND CAGE ASSEMBLIES, THRUST WASHERS – continued

INCH SERIES

- Dimensions for bore and O.D. of thrust assemblies and washers are nominal.
- See page B-310 for details on piloting and backup surfaces.
- Thrust washers burnished at least one-quarter of bore area (remainder is rough breakaway finish).
- O.D. finish of washers will be as blanked.
- Thinner washers may be out-of-flat due to distortion in hardening in the free state (expected to flatten out under load).

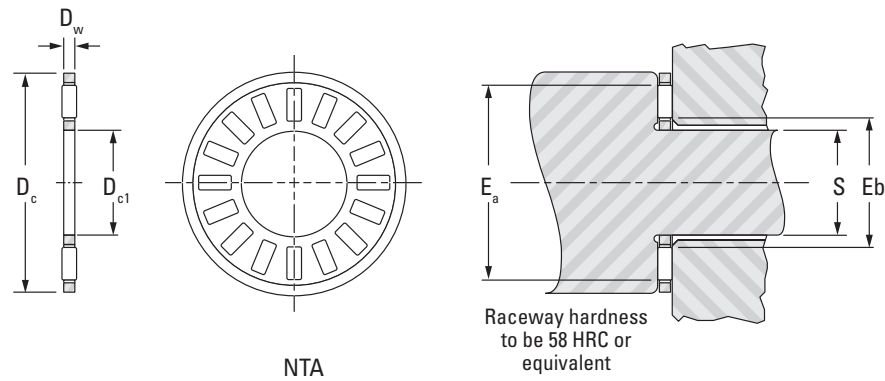

Shaft Dia.	D _{c1}	D _c	D _w	E _b	E _a	Assembly Designation	Load Ratings		Speed Rating ⁽¹⁾	Wt.
							Assembly Dimensions			
							Dynamic	Static		
in	mm in	mm in	mm in	mm in	mm in		kN lbf	min ⁻¹	kg lbs	
1 1/4	31.75 1.250	49.20 1.937	1.9837 0.0781	34.04 1.340	46.228 1.820	NTA-2031	20.15 4530	93.41 21000	8600	0.010 0.021
1 3/8	34.93 1.375	52.375 2.062	1.9837 0.0781	37.08 1.460	49.53 1.950	NTA-2233	21.35 4800	103.20 23200	8000	0.010 0.023
1 1/2	38.10 1.500	55.55 2.187	1.9837 0.0781	40.39 1.590	52.578 2.070	NTA-2435	23.22 5220	117.88 26500	7600	0.011 0.025
1 3/4	44.45 1.750	63.50 2.500	1.984 0.0781	46.74 1.840	58.928 2.320	NTA-2840	25.31 5690	137.45 30900	6800	0.014 0.031

⁽¹⁾Speed ratings listed are based on adequate oil lubrication. See page B-311 for lubrication information. Suggestions for an application requiring O.D. piloting should be determined in consultation with your representative.

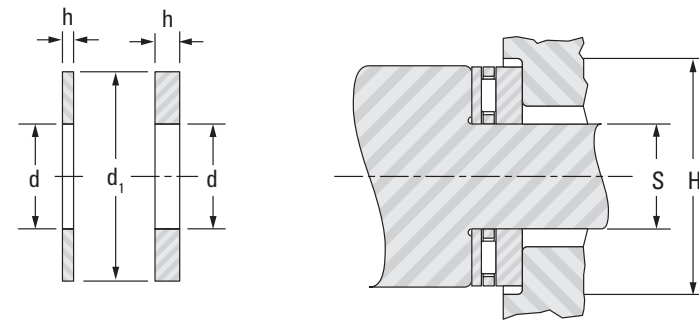

Thrust Washer Designation	d	d ₁	h		S		H ⁽²⁾	Washer Wt.	Shaft Dia.
			Washer Dimensions		Piloting Dimensions				
			Max.	Min.	Max.	Min.			
TRD-1828	28.58 1.125	44.45 1.750	3.20 0.126	3.12 0.123	28.58 1.125	28.50 1.122	45.24 1.781	0.022 0.048	
TRA-2031	31.75 1.250	49.20 1.937	0.81 0.032	0.76 0.030	31.75 1.250	31.67 1.247	50.01 1.969	0.007 0.015	1 1/4
TRB-2031	31.75 1.250	49.20 1.937	1.60 0.063	1.52 0.060	31.75 1.250	31.67 1.247	50.01 1.969	0.014 0.030	
TRC-2031	31.75 1.250	49.20 1.937	2.41 0.095	2.34 0.092	31.75 1.250	31.67 1.247	50.01 1.969	0.020 0.044	
TRD-2031	31.75 1.250	49.20 1.937	3.20 0.126	3.12 0.123	31.75 1.250	31.67 1.247	50.01 1.969	0.026 0.058	
TRF-2031	31.75 1.250	49.20 1.937	4.78 0.188	4.70 0.185	31.75 1.250	31.67 1.247	50.01 1.969	0.041 0.090	
TRA-2233	34.93 1.375	52.37 2.062	0.81 0.032	0.76 0.030	34.93 1.375	34.85 1.372	53.19 2.094	0.007 0.016	1 3/8
TRB-2233	34.93 1.375	52.37 2.062	1.60 0.063	1.52 0.060	34.93 1.375	34.85 1.372	53.19 2.094	0.015 0.033	
TRC-2233	34.93 1.375	52.37 2.062	2.41 0.095	2.34 0.092	34.93 1.375	34.85 1.372	53.19 2.094	0.018 0.040	
TRD-2233	34.93 1.375	52.37 2.062	3.20 0.126	3.12 0.123	34.93 1.375	34.85 1.372	53.19 2.094	0.029 0.065	
TRE-2233	34.93 1.375	52.37 2.062	3.99 0.157	3.91 0.154	34.93 1.375	34.85 1.372	53.19 2.094	0.037 0.081	
TRF-2233	34.93 1.375	52.37 2.062	4.78 0.188	4.70 0.185	34.93 1.375	34.85 1.372	53.19 2.094	0.044 0.097	
TRA-2435	38.10 1.500	55.55 2.187	0.81 0.032	0.76 0.030	38.10 1.500	38.02 1.497	56.36 2.219	0.008 0.017	1 1/2
TRB-2435	38.10 1.500	55.55 2.187	1.60 0.063	1.52 0.060	38.10 1.500	38.02 1.497	56.36 2.219	0.015 0.034	
TRC-2435	38.10 1.500	55.55 2.187	2.41 0.095	2.34 0.092	38.10 1.500	38.02 1.497	56.36 2.219	0.023 0.050	
TRD-2435	38.10 1.500	55.55 2.187	3.20 0.126	3.12 0.123	38.10 1.500	38.02 1.497	56.36 2.219	0.030 0.067	
TRF-2435	38.10 1.500	55.55 2.187	4.78 0.188	4.70 0.185	38.10 1.500	38.02 1.497	56.36 2.219	0.045 0.100	
TRA-2840	44.45 1.750	63.50 2.500	0.81 0.032	0.76 0.030	44.45 1.750	44.37 1.747	64.29 2.531	0.010 0.021	1 3/4
TRB-2840	44.45 1.750	63.50 2.500	1.60 0.063	1.52 0.060	44.45 1.750	44.37 1.747	64.29 2.531	0.020 0.044	

⁽²⁾If the shaft and the housing adjacent to the bearing O.D. are not concentric, the T.I.R. between the shaft and housing should be added to this dimension.

Continued on next page.

THRUST NEEDLE ROLLER AND CAGE ASSEMBLIES, THRUST WASHERS – continued

INCH SERIES

- Dimensions for bore and O.D. of thrust assemblies and washers are nominal.
- See page B-310 for details on piloting and backup surfaces.
- Thrust washers burnished at least one-quarter of bore area (remainder is rough breakaway finish).
- O.D. finish of washers will be as blanked.
- Thinner washers may be out-of-flat due to distortion in hardening in the free state (expected to flatten out under load).

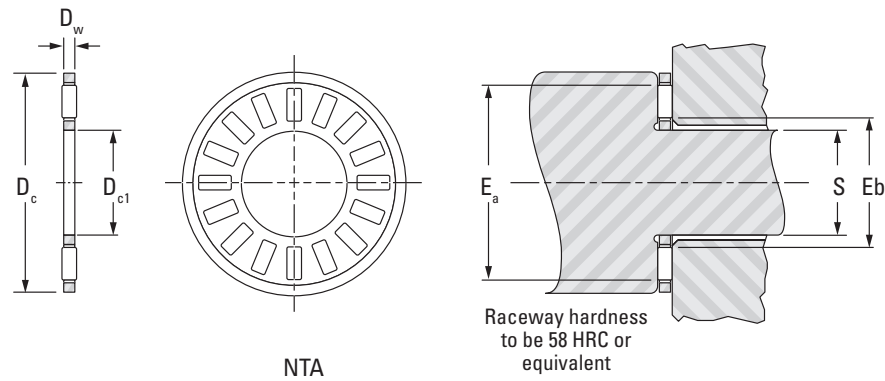

Shaft Dia.	D _{c1}	D _c	D _w	E _b	E _a	Assembly Designation	Load Ratings		Speed Rating ⁽¹⁾	Wt.
							Dynamic	Static		
							kN	lbf		
in	mm in	mm in	mm in	mm in	mm in				min ⁻¹	kg lbs
2	50.80 2.000	69.85 2.750	1.9837 0.0781	53.09 2.090	65.278 2.570	NTA-3244	24.02 5400	132.56 29800	6100	0.015 0.033
2 1/8	53.98 2.125	73.025 2.875	1.984 0.0781	56.39 2.220	68.58 2.700	NTA-3446	24.42 5490	137.45 30900	5800	0.016 0.036
2 1/4	57.15 2.250	76.20 3.000	1.984 0.0781	59.44 2.340	71.628 2.820	NTA-3648	24.78 5570	142.34 32000	5600	0.017 0.038
2 3/4	57.15 2.250	79.375 3.125	3.175 0.1250	59.94 2.360	75.184 2.960	NTA-3650	37.68 8470	177.04 39800	5300	0.029 0.064
2 1/2	63.50 2.500	82.55 3.250	1.9837 0.0781	65.79 2.590	77.978 3.070	NTA-4052	25.53 5740	152.13 34200	5100	0.019 0.041

⁽¹⁾Speed ratings listed are based on adequate oil lubrication. See page B-311 for lubrication information. Suggestions for an application requiring O.D. piloting should be determined in consultation with your representative.

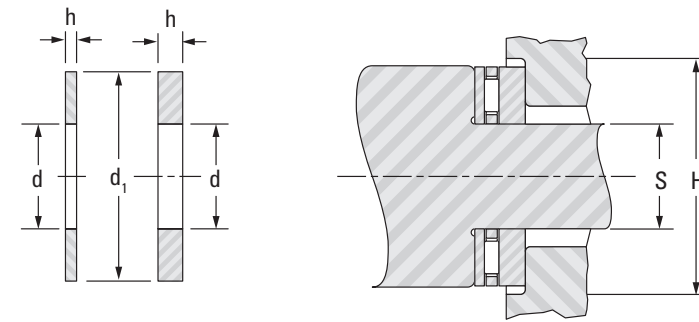

Thrust Washer Designation	d	d ₁	h		S		H ⁽²⁾ Dia. To Clear O.D.	Washer Wt. kg lbs	Shaft Dia. in
			Max.	Min.	Max.	Min.			
			mm in	mm in	mm in	mm in			
TRC-2840	44.45 1.750	63.50 2.500	2.41 0.095	2.34 0.092	44.45 1.750	44.37 1.747	64.29 2.531	0.029 0.063	
TRD-2840	44.45 1.750	63.50 2.500	3.20 0.126	3.12 0.123	44.45 1.750	44.37 1.747	64.29 2.531	0.038 0.084	
TRF-2840	44.45 1.750	63.50 2.500	4.78 0.188	4.70 0.185	44.45 1.750	44.37 1.747	64.29 2.531	0.057 0.126	
TRA-3244	50.80 2.000	69.85 2.750	0.81 0.032	0.76 0.030	50.80 2.000	50.72 1.997	70.64 2.781	0.011 0.024	2
TRB-3244	50.80 2.000	69.85 2.750	1.60 0.063	1.52 0.060	50.80 2.000	50.72 1.997	70.64 2.781	0.022 0.048	
TRC-3244	50.80 2.000	69.85 2.750	2.41 0.095	2.34 0.092	50.80 2.000	50.72 1.997	70.64 2.781	0.033 0.072	
TRD-3244	50.80 2.000	69.85 2.750	3.20 0.126	3.12 0.123	50.80 2.000	50.72 1.997	70.64 2.781	0.044 0.096	
TRF-3244	50.80 2.000	69.85 2.750	4.78 0.188	4.70 0.185	50.80 2.000	50.72 1.997	70.64 2.781	0.066 0.145	
TRA-3446	53.98 2.125	73.03 2.875	0.81 0.032	0.76 0.030	53.98 2.125	53.90 2.122	73.81 2.906	0.012 0.026	2 1/8
TRB-3446	53.98 2.125	73.03 2.875	1.60 0.063	1.52 0.060	53.98 2.125	53.90 2.122	73.81 2.906	0.024 0.052	
TRC-3446	53.98 2.125	73.03 2.875	2.41 0.095	2.34 0.092	53.98 2.125	53.90 2.122	73.81 2.906	0.035 0.078	
TRD-3446	53.98 2.125	73.03 2.875	3.20 0.126	3.12 0.123	53.98 2.125	53.90 2.122	73.81 2.906	0.047 0.103	
TRA-3648	57.15 2.250	76.20 3.000	0.81 0.032	0.76 0.030	57.15 2.250	57.07 2.247	76.99 3.031	0.012 0.026	2 1/4
TRB-3648	57.15 2.250	76.20 3.000	1.60 0.063	1.52 0.060	57.15 2.250	57.07 2.247	76.99 3.031	0.022 0.048	
TRC-3648	57.15 2.250	76.20 3.000	2.41 0.095	2.34 0.092	57.15 2.250	57.07 2.247	76.99 3.031	0.037 0.081	
TRD-3648	57.15 2.250	76.20 3.000	3.20 0.126	3.12 0.123	57.15 2.250	57.07 2.247	76.99 3.031	0.048 0.105	
TRF-3648	57.15 2.250	76.20 3.000	4.78 0.188	4.70 0.185	57.15 2.250	57.07 2.247	76.99 3.031	0.071 0.157	
					57.15 2.250	57.07 2.247	76.99 3.156		2 1/4
TRA-4052	63.50 2.500	82.55 3.250	0.81 0.032	0.76 0.030	63.50 2.500	63.42 2.497	83.34 3.281	0.013 0.029	2 1/2
TRB-4052	63.50 2.500	82.55 3.250	1.60 0.063	1.52 0.060	63.50 2.500	63.42 2.497	83.34 3.281	0.027 0.059	

⁽²⁾If the shaft and the housing adjacent to the bearing O.D. are not concentric, the T.I.R. between the shaft and housing should be added to this dimension.

Continued on next page.

THRUST NEEDLE ROLLER AND CAGE ASSEMBLIES, THRUST WASHERS – continued

INCH SERIES

- Dimensions for bore and O.D. of thrust assemblies and washers are nominal.
- See page B-310 for details on piloting and backup surfaces.
- Thrust washers burnished at least one-quarter of bore area (remainder is rough breakaway finish).
- O.D. finish of washers will be as blanked.
- Thinner washers may be out-of-flat due to distortion in hardening in the free state (expected to flatten out under load).

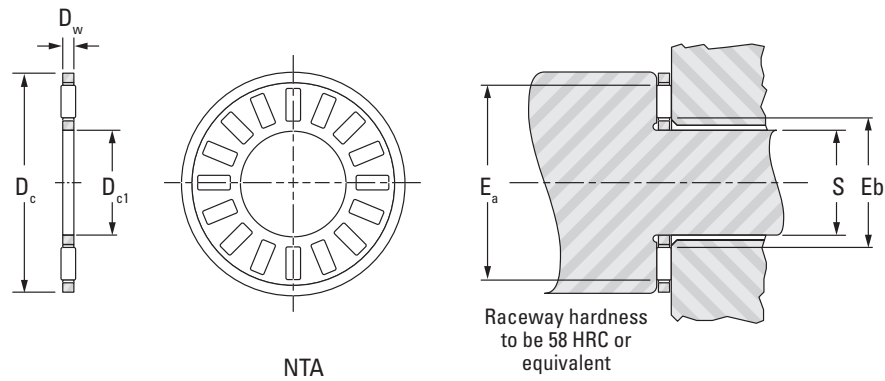

Shaft Dia.	D _{c1}	D _c	D _w	E _b	E _a	Assembly Designation	Load Ratings		Speed Rating ⁽¹⁾	Wt.
							Dynamic	Static		
							kN lbf			
in	mm in	mm in	mm in	mm in	mm in				min ⁻¹	kg lbs
2 3/4	69.85 2.750	92.075 3.625	3.175 0.1250	72.64 2.860	87.884 3.460	NTA-4458	47.60 10700	255.8 57500	4600	0.037 0.082
3	76.20 3.000	95.25 3.750	1.9837 0.0781	78.49 3.090	90.678 3.570	NTA-4860	26.96 6060	172.1 38700	4400	0.022 0.048
3 1/4	82.55 3.250	104.78 4.125	3.175 0.1250	85.34 3.360	100.58 3.960	NTA-5266	51.60 11600	294.9 66300	4000	0.042 0.092
3 3/4	95.25 3.750	117.48 4.625	3.175 0.1250	98.04 3.860	113.28 4.460	NTA-6074	56.05 12600	344.3 77400	3500	0.050 0.11
4 1/8	104.78 4.125	128.57 5.062	3.175 0.125	107.44 4.230	124.46 4.900	NTA-6681	63.61 14300	414.6 93200	3200	0.062 0.136

⁽¹⁾Speed ratings listed are based on adequate oil lubrication. See page B-311 for lubrication information. Suggestions for an application requiring O.D. piloting should be determined in consultation with your representative.

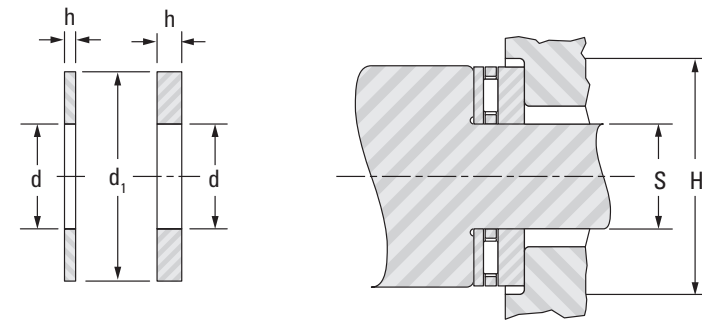

Thrust Washer Designation	d	d ₁	h		S		H ⁽²⁾ Dia. To Clear O.D.	Washer Wt.	Shaft Dia.
			Max.	Min.	Max.	Min.			
			mm in	mm in	mm in	mm in			
TRC-4052	63.50 2.500	82.55 3.250	2.41 0.095	2.34 0.092	63.50 2.500	63.42 2.497	83.34 3.281	0.041 0.09	
TRC-4052	63.50 2.500	82.55 3.250	3.20 0.126	3.12 0.123	63.50 2.500	63.42 2.497	83.34 3.281	0.054 0.119	
TRA-4458	69.85 2.750	92.08 3.625	0.81 0.032	0.76 0.030	69.85 2.750	69.77 2.747	92.86 3.656	0.018 0.039	2 3/4
TRB-4458	69.85 2.750	92.08 3.625	1.60 0.063	1.52 0.060	69.85 2.750	69.77 2.747	92.86 3.656	0.035 0.077	
TRC-4458	69.85 2.750	92.08 3.625	2.41 0.095	2.34 0.092	69.85 2.750	69.77 2.747	92.86 3.656	0.051 0.113	
TRD-4458	69.85 2.750	92.08 3.625	3.20 0.126	3.12 0.123	69.85 2.750	69.77 2.747	92.86 3.656	0.069 0.152	
TRF-4458	69.85 2.750	92.08 3.625	4.78 0.188	4.70 0.185	69.85 2.750	69.77 2.747	92.86 3.656	0.104 0.229	
TRA-4860	76.20 3.000	95.25 3.750	0.81 0.032	0.76 0.030	76.20 3.000	76.12 2.997	96.04 3.781	0.015 0.034	3
TRB-4860	76.20 3.000	95.25 3.750	1.60 0.063	1.52 0.060	76.20 3.000	76.12 2.997	96.04 3.781	0.032 0.07	
TRD-4860	76.20 3.000	95.25 3.750	3.20 0.126	3.12 0.123	76.20 3.000	76.12 2.997	96.04 3.781	0.061 0.135	
TRA-5266	82.55 3.250	104.78 4.125	0.81 0.032	0.76 0.030	82.55 3.250	82.47 3.247	105.56 4.156	0.020 0.044	3 1/4
TRD-5266	82.55 3.250	104.78 4.125	3.20 0.126	3.12 0.123	82.55 3.250	82.47 3.247	105.56 4.156	0.080 0.176	
TRA-6074	95.25 3.750	117.48 4.625	0.81 0.032	0.76 0.030	95.25 3.750	95.17 3.747	118.26 4.656	0.023 0.05	3 3/4
TRB-6074	95.25 3.750	117.48 4.625	1.60 0.063	1.52 0.060	95.25 3.750	95.17 3.747	118.26 4.656	0.046 0.101	
TRC-6074	95.25 3.750	117.48 4.625	2.41 0.095	2.34 0.092	95.25 3.750	95.17 3.747	118.26 4.656	0.069 0.152	
TRD-6074	95.25 3.750	117.48 4.625	3.20 0.126	3.12 0.123	95.25 3.750	95.17 3.747	118.26 4.656	0.092 0.202	
TRA-6681	104.78 4.125	128.57 5.062	0.81 0.032	0.76 0.030	104.78 4.125	104.70 4.122	129.39 5.094	0.027 0.059	4 1/8
TRC-6681	104.78 4.125	128.57 5.062	2.41 0.095	2.34 0.092	104.78 4.125	104.70 4.122	129.39 5.094	0.081 0.178	
TRD-6681	104.78 4.125	128.57 5.062	3.20 0.126	3.12 0.123	104.78 4.125	104.70 4.122	129.39 5.094	0.109 0.24	
TRF-6681	104.78 4.125	128.57 5.062	4.78 0.188	4.70 0.185	104.78 4.125	104.70 4.122	129.39 5.094	0.161 0.354	

⁽²⁾If the shaft and the housing adjacent to the bearing O.D. are not concentric, the T.I.R. between the shaft and housing should be added to this dimension.

THRUST CYLINDRICAL ROLLER AND CAGE ASSEMBLIES

INCH SERIES

- Backup surfaces should be flat and square with the centerline of the shaft.
- See pages B-310 for details on piloting and backup surfaces.

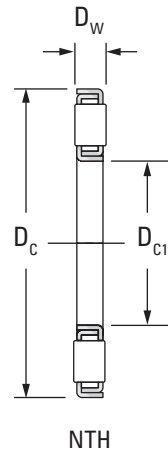

Shaft Dia.	D _{c1}	D _c	D _w	Assembly Designation	C		Speed Rating ⁽¹⁾
					Load Ratings		
					Dynamic	Static	
in	mm in	mm in	mm in		kN lbf		min ⁻¹
1 1/2	38.15 1.502	75.44 2.970	6.35 0.250	NTH-2448	81.8 18400	280 62900	5700
2	50.85 2.002	91.31 3.595	9.53 0.375	NTH-3258	129 29000	407 91600	4700
2 1/8	54.03 2.127	94.49 3.720	9.53 0.375	NTH-3460	133 30000	433 97400	4500
2 1/4	57.20 2.252	97.66 3.845	9.53 0.375	NTH-3662	138 31100	458 103000	4400
2 3/8	60.38 2.377	100.84 3.970	9.53 0.375	NTH-3864	143 32100	484.9 109000	4200
2 1/2	63.55 2.502	104.01 4.095	9.53 0.375	NTH-4066	147 33000	511 115000	4100
2 5/8	66.73 2.627	109.60 4.315	9.53 0.375	NTH-4270	156 35100	556 125000	3900
2 3/4	69.98 2.755	112.78 4.440	9.53 0.375	NTH-4472	161 36100	587 132000	3800
3	76.33 3.005	119.13 4.690	9.53 0.375	NTH-4876	169 38000	641 144000	3600
3 1/4	82.68 3.255	125.48 4.940	9.53 0.375	NTH-5280	178 39900	698 157000	3400
3 1/2	89.03 3.505	132.26 5.207	9.53 0.375	NTH-5684	180 40500	725 163000	3200

⁽¹⁾ Speed ratings listed are based on adequate oil lubrication. See page B-311 for lubrication information.

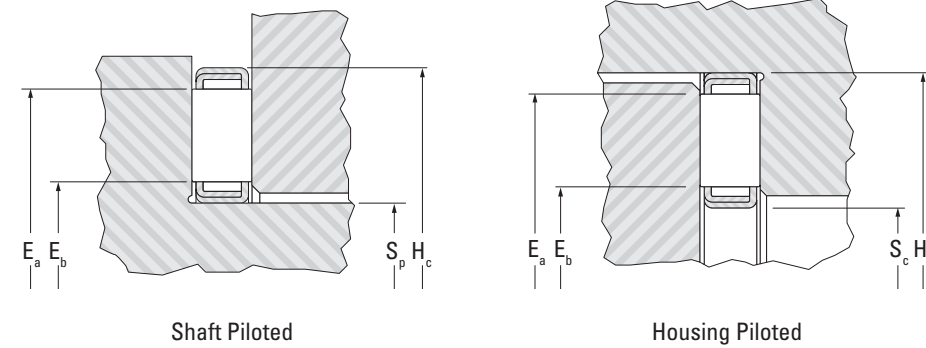

Assembly Wt.	S _p		H _c		S _c		H _p		E _b		E _a		Shaft Dia.
	Piloting Dimensions												
	Shaft Piloting				Housing Piloting				Raceway Contact				
	+0, +0.000						+0.13, +0.005						
	-0.13, -0.005		Min.		Max.		-0, -0.000						
kg lbs	mm in	mm in	mm in	mm in	mm in	mm in	mm in	mm in	mm in	mm in	mm in	in	
0.10 0.23	38.10 1.500	76.96 3.030	36.63 1.442	75.57 2.975	44.70 1.760	68.83 2.710	1 1/2						
0.21 0.47	50.80 2.000	92.84 3.655	49.33 1.942	91.44 3.600	57.40 2.260	84.33 3.320	2						
0.22 0.49	53.98 2.125	96.01 3.780	52.5 2.067	94.62 3.725	60.71 2.390	87.38 3.440	2 1/8						
0.24 0.52	57.15 2.250	99.19 3.905	55.68 2.192	97.79 3.850	63.75 2.510	90.68 3.570	2 1/4						
0.24 0.54	60.33 2.375	102.36 4.030	58.85 2.317	100.97 3.975	67.06 2.640	93.73 3.690	2 3/8						
0.26 0.57	63.50 2.500	105.54 4.155	62.03 2.442	104.14 4.100	70.10 2.760	97.03 3.820	2 1/2						
0.28 0.62	66.68 2.625	111.13 4.375	65.2 2.567	109.73 4.320	73.41 2.890	102.36 4.030	2 5/8						
0.29 0.64	69.85 2.750	114.30 4.500	68.45 2.695	112.90 4.445	76.45 3.010	105.66 4.160	2 3/4						
0.31 0.69	76.20 3.000	120.65 4.750	74.8 2.945	119.25 4.695	82.80 3.260	112.01 4.410	3						
0.34 0.75	82.55 3.250	127.00 5.000	81.15 3.195	125.60 4.945	89.15 3.510	118.36 4.660	3 1/4						
0.37 0.81	88.90 3.500	133.78 5.267	87.5 3.445	132.38 5.212	95.76 3.770	125.73 4.950	3 1/2						

CYLINDRICAL ROLLER THRUST BEARINGS

- The NTHA thrust cylindrical roller bearing consists of an NTH roller and cage assembly, one bore piloted washer and one O.D. piloted washer. The NTHA bearing is identified and sold as a unit and is manufactured to inch-nominal dimensions only.
- Load ratings given are identical to the corresponding NTH thrust cylindrical roller and cage assembly.
- It is suggested that the roller and cage assembly be bore piloted when applying NTHA bearings. When different arrangements of piloting are required, please contact your representative.
- Backup surfaces should be flat and square with the center line of the shaft.
- To order individual thrust washers, see washer designation below.

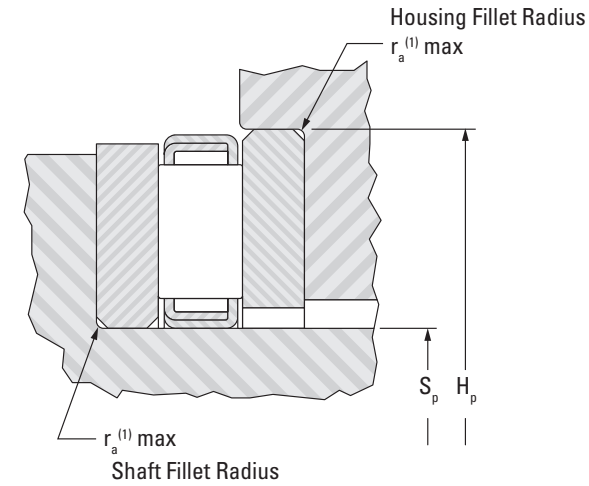
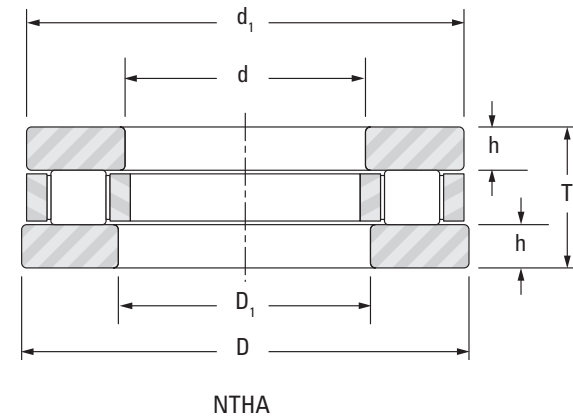

Shaft Dia.	d			d ₁			T +0.000 -0.006	Bearing Designation	Bearing Wt.
	Shaft-Piloted Washer			Housing-Piloted Washer					
	Max.	Min.	Nom.	Max.	Min.	Nom.			
in	mm in	mm in	mm in	mm in	mm in	mm in	mm in		kg lbs
1 1/2	38.100 1.5000	38.082 1.4993	74.613 2 15/16	76.218 3.0007	76.200 3.0000	39.688 1 9/16	20.62 0.812	NTHA-2448	0.47 1.03
2	50.800 2.0000	50.775 1.9990	90.488 3 9/16	92.098 3.6259	92.075 3.6250	52.388 2 1/16	25.40 1.000	NTHA-3258	0.76 1.68
2 1/8	53.975 2.1250	53.950 2.1240	93.663 3 11/16	95.278 3.7511	95.250 3.7500	55.563 2 3/16	25.40 1.000	NTHA-3460	0.80 1.76
2 1/4	57.150 2.2500	57.122 2.2489	96.838 3 13/16	98.453 3.8761	98.425 3.8750	58.738 2 5/16	25.40 1.000	NTHA-3662	0.83 1.84
2 3/8	60.325 2.3750	60.297 2.3739	100.013 3 15/16	101.628 4.0011	101.600 4.0000	61.913 2 7/16	25.40 1.000	NTHA-3864	0.87 1.91
2 1/2	63.500 2.5000	63.472 2.4989	103.188 4 1/16	104.808 4.1263	104.775 4.1250	65.088 2 9/16	25.40 1.000	NTHA-4066	0.90 1.99
2 5/8	66.675 2.6250	66.645 2.6238	108.744 4 9/32	110.345 4.3443	110.312 4.3430	68.263 2 11/16	25.40 1.000	NTHA-4270	1.01 2.22
2 3/4	69.850 2.7500	69.820 2.7488	111.919 4 13/32	113.520 4.4693	113.487 4.4680	71.438 2 13/16	25.40 1.000	NTHA-4472	1.04 2.29
3	76.200 3.0000	76.170 2.9988	118.269 4 21/32	119.875 4.7195	119.837 4.7180	77.788 3 1/16	25.40 1.000	NTHA-4876	1.12 2.46
3 1/4	82.550 3.2500	82.517 3.2487	124.619 4 29/32	126.225 4.9695	126.187 4.9680	84.138 3 5/16	25.40 1.000	NTHA-5280	1.19 2.62
3 1/2	88.900 3.5000	88.867 3.4987	130.969 5 9/32	132.575 5.2195	132.537 5.2180	90.488 3 9/16	25.40 1.000	NTHA-5684	1.27 2.80

(1) r_a max is equal to minimum washer chamfer r_s min.

C	C ₀	Speed Rating Oil	Piloting Dimensions				Bore Piloted Washer	Washer Wt.	O.D. Piloted Washer	Washer Wt.	Shaft Dia.
			S _p		H _p						
			+0, +0.000		+0.13, +0.005						
			-0.13, -0.005		-0, -0.000						
81.8 18400	280 62900	5700	38.082 1.4993	76.218 3.0007	0.81 0.032	7.137 0.2810	TRI-2448	0.18 0.39	TRID-2448	0.18 0.39	1 1/2
129 29000	408 91600	4700	50.775 1.9990	92.098 3.6259	1.57 0.062	7.938 0.3125	TRJ-3258	0.26 0.57	TRJD-3258	0.27 0.59	2
133 30000	433 97400	4500	53.950 2.1240	95.278 3.7511	1.57 0.062	7.938 0.3125	TRJ-3460	0.27 0.60	TRJD-3460	0.28 0.61	2 1/8
138 31100	458 103000	4400	57.122 2.2489	98.453 3.8761	1.57 0.062	7.938 0.3125	TRJ-3662	0.28 0.62	TRJD-3662	0.29 0.64	2 1/4
143 32100	485 109000	4200	60.297 2.3739	101.628 4.0011	1.57 0.062	7.938 0.3125	TRJ-3864	0.29 0.65	TRJD-3864	0.30 0.66	2 3/8
147 33000	512 115000	4100	63.472 2.4989	104.808 4.1263	1.57 0.062	7.938 0.3125	TRJ-4066	0.30 0.67	TRJD-4066	0.31 0.69	2 1/2
156 35100	556 125000	3900	66.645 2.6238	110.345 4.3443	1.57 0.062	7.938 0.3125	TRJ-4270	0.34 0.75	TRJD-4270	0.35 0.77	2 5/8
161 36100	587 132000	3800	69.820 2.7488	113.520 4.4693	1.57 0.062	7.938 0.3125	TRJ-4472	0.35 0.78	TRJD-4472	0.36 0.80	2 3/4
169 38000	641 144000	3600	76.170 2.9988	119.875 4.7195	1.57 0.062	7.938 0.3125	TRJ-4876	0.38 0.83	TRJD-4876	0.39 0.85	3
177 39900	698 157000	3400	82.517 3.2487	126.225 4.9695	1.57 0.062	7.938 0.3125	TRJ-5280	0.40 0.89	TRJD-5280	0.41 0.91	3 1/4
180 40500	725 163000	3200	88.867 3.4987	132.575 5.2195	1.57 0.062	7.938 0.3125	TRJ-5684	0.43 0.94	TRJD-5284	0.43 0.96	3 1/2

NOTES

COMBINED NEEDLE ROLLER BEARINGS

Overview: Combined bearings incorporate a radial needle roller bearing and a thrust ball or roller bearing into a convenient unitized package.

- **Sizes:** 5.000 mm – 70.000 mm (0.1966 in – 2.7559 in) bore.
- **Markets:** Industrial applications, machine tools, and automotive transmissions.
- **Features:** Available with ball, needle roller or cylindrical roller thrust component, machined and drawn outer rings are available, some sizes available with integral dust caps.
- **Benefits:** An effective alternative to separate radial and thrust bearings.

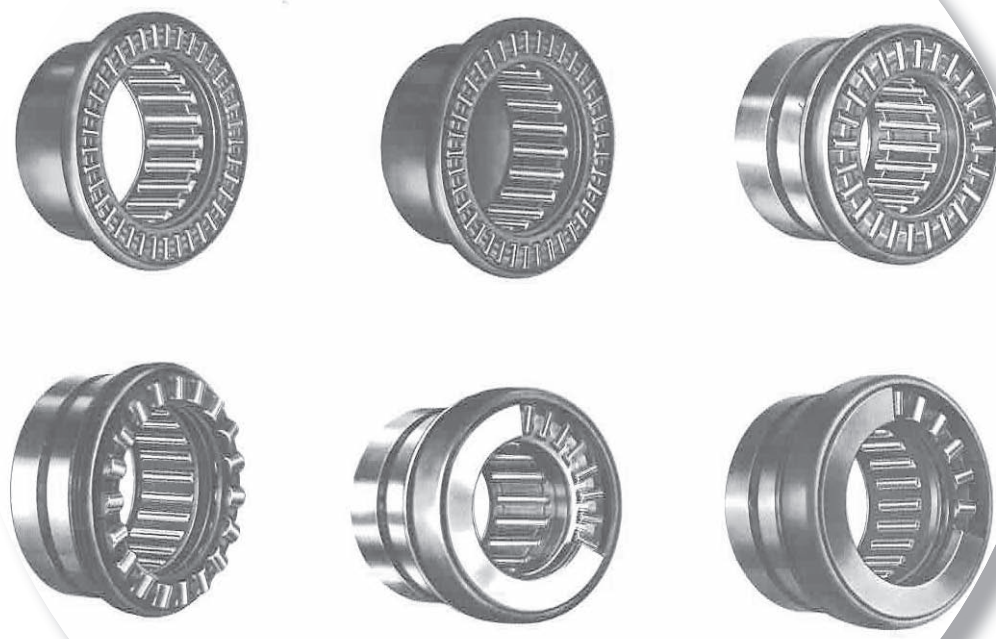

Combined Needle Roller Bearings – Metric Nominal Dimensions

Prefix
RAX radial needle roller and thrust needle (or cylindrical) roller bearing without inner ring or thrust washer
RAXF closed-end drawn cup design radial needle roller and needle thrust roller bearing without inner ring or thrust washer
RAXZ unitized machined outer ring thrust cylindrical roller and radial needle roller bearing
NAXR machined outer ring thrust cylindrical roller and radial needle roller bearing without inner ring
NAXK machined outer ring thrust ball and radial needle roller bearing without inner ring

RAXF 7 15 TC
NAXR 20 Z.TN

Suffix
TN molded polymer retainer
Z thrust washer retaining dust cap
TB radial play under rollers set to lower half of F6 tolerance
TC radial play under rollers set to upper half of F6 tolerance

Bore Diameter
 20 = 20.000 mm

Series (RAX)
700 drawn cup design radial needle roller and needle thrust roller bearing without inner ring or thrust washer
400 machined ring radial needle roller and thrust needle roller bearing without inner ring or thrust washer
500 machined ring radial needle roller and thrust cylindrical roller bearing

Inner Rings for Combined Needle Roller Bearings – Metric Nominal Dimensions

Prefix
JR inner ring for use with NAXR series bearings
IM inner ring for use RAX series bearings

JR 25 x 30 x 18
IM 10 14 16 P

Bore Diameter
 25 = 25.000 mm

Width
 18 = 18.000 mm

Outer Diameter
 14 = 14.000 mm

Suffix (IM Series)
P ISO 492 toleranced inner ring

Thrust Washers for Combined Needle Roller Bearings - Metric Nominal Dimensions

Prefix
CP thrust washer for metric needle roller bearings

CP 15 28 — thin washer designation
CP 2 15 28 — thick washer designation

Thickness
 2 = 2.000 mm

Outer Diameter
 28 = 28.000 mm

Bore Diameter
 15 = 15.000 mm

Combined Needle Roller Bearings

Page

Introduction	B-330
Ball Thrust Series – Metric Series	B-332
Cylindrical Roller Thrust Series – Metric Series	B-336
Needle Roller and Cylindrical Roller Thrust Series – Metric Series	B-340
Drawn Cup, Needle Roller Thrust Series Open and Closed Bearings – Metric Series	B-344



COMBINED BEARINGS

METRIC SERIES

Combined bearings consist of a radial bearing (needle roller bearing) and a thrust bearing (ball, roller or needle bearing). The thrust roller bearing is usually a cylindrical roller thrust bearing.

Combined bearings make an effective alternative in place of two separate bearings—in terms of cost, handling and packaging. Combined bearings can be used with or without matching inner rings and thrust washers—though these are listed opposite the bearing part numbers, where possible, on the following pages of tables for convenience.

REFERENCE STANDARDS ARE:

- **DIN 5429, Part 1** – needle roller – thrust cylindrical roller bearings, series NAXR, NAXR.Z.
- **DIN 5429, Part 1** – needle roller – thrust ball bearings, series NAXK, NAXK.Z.
- **ISO 1206** – needle roller bearings – light and medium series – dimensions and tolerances.

Needle roller-ball thrust bearing

Needle roller-needle roller thrust bearings

Needle roller-cylindrical roller thrust bearings

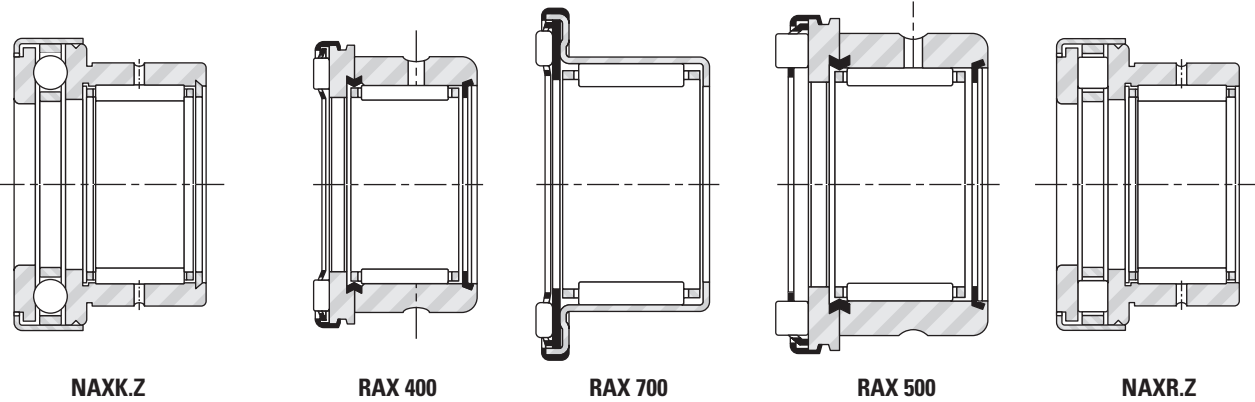

Fig. B-79. Types of metric series combined bearings

Suffixes

TN	molded cage of reinforced engineered polymer
Z	retained with a dust cap
Z.TN	retained with a dust cap, molded cage of reinforced engineered polymer
TB	radial play under rollers set to lower half of F6 tolerance limits
TC	radial play under rollers set to upper half of F6 tolerance limits

CONSTRUCTION

Needle roller-cylindrical roller thrust bearings of series NAXR and RAXZ 500 are available with dust caps. They have the highest axial load-carrying capability of all combined bearings. The NAXR and NAXR.Z Series have the same dimensions as needle roller-ball thrust bearings (series NAXK and NAXK.Z).

Combined bearings of series RAX 700 use a thin, one-piece outer ring design, similar in construction to metric drawn cups. The RAX 700 Series is available with an open or closed (RAXF) design, as are standard drawn cups. These bearings use needle rollers for both their radial and thrust complements.

The RAX 400 Series uses needle rollers for both their radial and thrust complements, as with the RAX 700 Series, but are constructed from two separate machined rings, joined with a strong metal insert. The RAX 500 Series, fabricated like the 400 Series, uses heavier cylindrical rollers for their thrust complement.

Both series are available with matching thrust washers and inner rings. These series should be considered for applications requiring higher load capacity and running accuracy.

Each of the previous two bearing types may be best used without inner rings because the radial internal clearances are smaller if the needle roller and cage assemblies operate directly on a hardened and ground shaft. Tolerance class F6 is the normal specification for the needle roller complement bore diameters of the unmounted bearings.

RAX 400 and 500 Series (without inner rings) can be supplied with a smaller radial clearance, if desired. Refer to the suffix options TB and TC, as listed in the chart above.

Quality requirements for shafts, when used as a bearing raceway, are given in the engineering section of this catalog. When it becomes impractical to meet the shaft raceway design requirements, standard inner rings may be used with these bearings.

DIMENSIONAL ACCURACY

TOLERANCES

Metric series combined bearings (except Series RAX 700) are manufactured to the normal tolerances which apply to the metric series radial bearings and standard thrust bearings, as shown in the engineering section. The only exceptions are the diameter tolerances of the shaft-piloted washer and the bearing width tolerances. The shaft-piloted washer bore tolerance is E7 for the NAXK, NAXR, NAXK.Z and NAXR.Z Series bearings. The thickness tolerance of the combined bearings thrust component (C₁) can be found in Table B-58. The matching thrust washer thickness tolerance may be found in the metric unitized thrust bearing section of this catalog.

Because of the nature of the RAX 700 Series design, these bearings must be inspected with suitable plug ("go" and "no go") and ring gage. The plug and ring gage sizes are listed in the inspection columns of the RAX700 Series product table.

BEARING MOUNTING

MOUNTING DIMENSIONS

Simple, through-bored housings are adequate for combined bearings. The mounting tolerances for the mechanical-ring combined bearings are provided in Table B-57.

The shaft-piloted washers of combined bearings must be supported, at least over half of their width. Other quality requirements for shafts and housings are given in the engineering section. Requirements for fillets, recesses and shoulder heights are the same as for needle roller bearings, as shown in the Mounting Dimensions paragraph on pages B-151 and B-152.

When mounting these bearings in their housings with a tight fit, relatively high press-in forces will be required which may brinell the raceways of the thrust bearing arrangements. Particular care should be exercised when installing needle roller-cylindrical roller thrust bearings with dust caps – and where the roller assembly of the thrust bearings cannot be removed. In order to avoid brinelling of the thrust bearing raceways, the bearings should be installed with uniform, continuous pressure against the installation tool, avoiding sudden impact forces. At times it may even be desirable to heat the housing before bearing mounting.

Table B-57. Mounting tolerances

Rotation conditions	ISO tolerance zone for housing	d		With inner ring	Without inner ring
		>	≤		
		Nominal shaft diameter		ISO tolerance zone for shaft	
Load stationary relative to housing	K6 (M6) ⁽¹⁾	mm 10.000 0.3937	mm 40.000 1.5748	k6	h6
		mm 40.000 1.5748	mm 70.000 2.7559	m6	h6
Load rotates relative to housing	M6 (N6) ⁽¹⁾	All diameters		g6	f6
RAX 700 RAXF 700	H6 (H7)	All diameters		k5	h5 (h6)

⁽¹⁾ Tighter fit for more secure arrangement.

Table B-58. Thrust component thickness (C₁) tolerances

Bearing series	Tolerance	
	mm	in
NAXK, NAXK.Z	+0.000 / -0.200	+0.000 / -0.0078
NAXR, NAXR.Z		
RAX 400, RAX 500	+0.050 / -0.060	+0.0020 / -0.0024
RAX 700, RAXF 700	±0.100	±0.0039
RAXZ	+0.100 / -0.110	+0.0039 / -0.0043

LUBRICATION

When the applied axial loads are relatively high and the application allows the use of oil as the desired method of lubrication, bearing types NAXR and NAXK should be given consideration. Combined bearings with a dust cap may use oil lubrication, although their design makes them better suited for use with grease lubrication.

Combined bearings are typically shipped protected with a corrosion-preventive compound that is not a lubricant. The bearings may be used in oil- or grease-lubricated applications, without removal of the corrosion-preventive compound. However, it may be advisable to remove the corrosion-preventive compound before packing the bearings (with a suitable grease) to obtain optimum grease performance and to minimize the possibility of confusing grease bearings with bearings containing corrosion preventive.

LOAD RATINGS

Minimum axial load for combined bearings excluding RAX700:

$$F_{amin} = C_0 / 2200 \quad (\text{kN})$$

Where:

$$C_0 = \text{static load rating} \quad (\text{kN})$$

DYNAMIC EQUIVALENT LOAD

Combined bearings can accommodate radial and axial loads.

Radial needle roller complement

$$P = F_r \quad (\text{kN})$$

Cylindrical or needle roller thrust complement

$$P_a = F_a \quad (\text{kN})$$

STATIC EQUIVALENT LOAD

For all combined bearings series:

Radial needle roller complement

$$P_0 = F_r \quad (\text{kN})$$

Cylindrical or needle roller thrust complement

$$P_{0a} = F_a \quad (\text{kN})$$



BALL THRUST SERIES METRIC SERIES

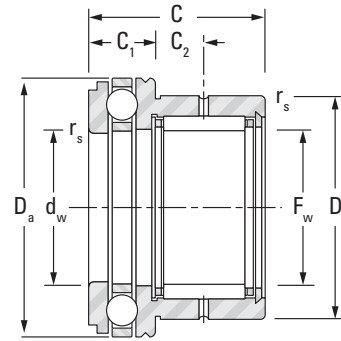

NAXK

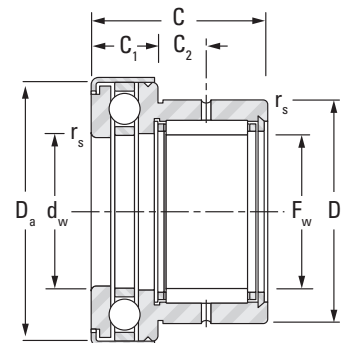

NAXK.Z

Shaft Diameter	F _w	D	C	d _w	D _a	C ₁	C ₂	r _{s min}
				E7				
				mm in				
10 0.394	10 0.394	19 0.748	23 0.906	10 0.394	24 0.945	9 0.354	6.5 0.256	0.3 0.012
	10 0.394	19 0.748	23 0.906	10 0.394	25 0.984	9 0.354	6.5 0.256	0.3 0.012
12 0.472	12 0.472	21 0.827	23 0.906	12 0.472	26 1.024	9 0.354	6.5 0.256	0.3 0.012
	12 0.472	21 0.827	23 0.906	12 0.472	27 1.063	9 0.354	6.5 0.256	0.3 0.012
15 0.591	15 0.591	24 0.945	23 0.906	15 0.591	28 1.102	9 0.354	6.5 0.256	0.3 0.012
	15 0.591	24 0.945	23 0.906	15 0.591	29 1.142	9 0.354	6.5 0.256	0.3 0.012
17 0.669	17 0.669	26 1.024	25 0.984	17 0.669	30 1.181	9 0.354	8 0.315	0.3 0.012
	17 0.669	26 1.024	25 0.984	17 0.669	31 1.220	9 0.354	8 0.315	0.3 0.012
20 0.787	20 0.787	30 1.181	30 1.181	20 0.787	35 1.378	10 0.394	10.5 0.413	0.3 0.012
	20 0.787	30 1.181	30 1.181	20 0.787	36 1.417	10 0.394	10.5 0.413	0.3 0.012
25 0.984	25 0.984	37 1.457	30 1.181	25 0.984	42 1.654	11 0.433	9.5 0.374	0.6 0.024
	25 0.984	37 1.457	30 1.181	25 0.984	43 1.693	11 0.433	9.5 0.374	0.6 0.024
30 1.181	30 1.181	42 1.654	30 1.181	30 1.181	47 1.850	11 0.433	9.5 0.374	0.6 0.024
	30 1.181	42 1.654	30 1.181	30 1.181	48 1.890	11 0.433	9.5 0.374	0.6 0.024
35 1.378	35 1.378	47 1.850	30 1.181	35 1.378	52 2.047	12 0.472	9 0.354	0.6 0.024
	35 1.378	47 1.850	30 1.181	35 1.378	53 2.087	12 0.472	9 0.354	0.6 0.024
40 1.575	40 1.575	52 2.047	32 1.260	40 1.575	60 2.362	13 0.512	10 0.394	0.6 0.024
	40 1.575	52 2.047	32 1.260	40 1.575	61 2.402	13 0.512	10 0.394	0.6 0.024
45 1.772	45 1.772	58 2.283	32 1.260	45 1.772	65 2.559	14 0.551	9 0.354	0.6 0.024
	45 1.772	58 2.283	32 1.260	45 1.772	66.5 2.618	14 0.551	9 0.354	0.6 0.024

Bearing Designation	Speed Rating Oil	Load Ratings				Wt.	Matching Inner ring Designation	Shaft Diameter
		Radial		Thrust				
		Dynamic	Static	Dynamic	Static			
		C	C ₀	C	C ₀			
	min ⁻¹	kN lbf		kN lbf		kg	mm in	
NAXK10	9500	7.9 1780	8.7 1960	10.4 2340	14 3150	0.04	JR7x10x16	10 0.394
NAXK10Z	9500	7.9 1780	8.7 1960	10.4 2340	14 3150	0.04	JR7x10x16	
NAXK12	9000	7.5 1690	8.5 1910	10.7 2410	15.4 3460	0.046	JR9x12x16	12 0.472
NAXK12Z	9000	7.5 1690	8.5 1910	10.7 2410	15.4 3460	0.047	JR9x12x16	
NAXK15	8500	9.7 2180	12.6 2830	10.9 2450	16.8 3780	0.047	JR12x15x16	15 0.591
NAXK15Z	8500	9.7 2180	12.6 2830	10.9 2450	16.8 3780	0.05	JR12x15x16	
NAXK17	8500	11.4 2560	16.1 3620	11.8 2650	19.6 4410	0.06	JR14x17x17	17 0.669
NAXK17Z	8500	11.4 2560	16.1 3620	11.8 2650	19.6 4410	0.064	JR14x17x17	
NAXK20	7000	14.8 3330	23.7 5330	15.5 3480	26.6 5980	0.089	JR17x20x20	20 0.787
NAXK20Z	7000	14.8 3330	23.7 5330	15.5 3480	26.6 5980	0.094	JR17x20x20	
NAXK25	6300	18.8 4230	29.8 6700	18.8 4230	35.5 7980	0.134	JR20x25x20	25 0.984
NAXK25Z	6300	18.8 4230	29.8 6700	18.8 4230	35.5 7980	0.141	JR20x25x20	
NAXK30	5600	20.2 4540	34.6 7780	19.5 4380	39.9 8970	0.146	JR25x30x20	30 1.181
NAXK30Z	5600	20.2 4540	34.6 7780	19.5 4380	39.9 8970	0.154	JR25x30x20	
NAXK35	5300	22.1 4970	40.8 9170	20.8 4680	46.6 10480	0.176	JR30x35x20	35 1.378
NAXK35Z	5300	22.1 4970	40.8 9170	20.8 4680	46.6 10480	0.184	JR30x35x20	
NAXK40	4500	23.8 5350	47 10570	28 6290	62.9 14140	0.224	JR35x40x20	40 1.575
NAXK40Z	4500	23.8 5350	47 10570	28 6290	62.9 14140	0.233	JR35x40x20	
NAXK45	4500	24.9 5600	51.8 11650	29 6520	69.2 15560	0.262	JR40x45x20	45 1.772
NAXK45Z	4500	24.9 5600	51.8 11650	29 6520	69.2 15560	0.275	JR40x45x20	

Continued on next page.



BALL THRUST SERIES — *continued*
METRIC SERIES

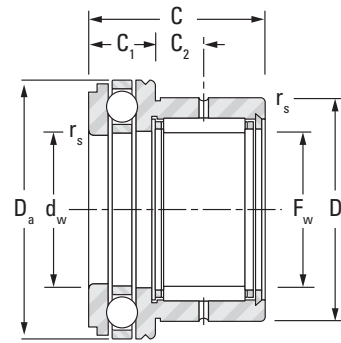

NAXK

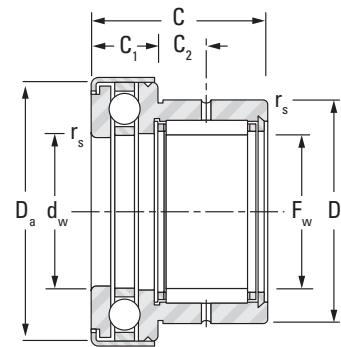

NAXK.Z

Shaft Diameter	F _w	D	C	d _w	D _a	C ₁	C ₂	r _{s min}
				E7				
mm in	mm in	mm in	mm in	mm in	mm in	mm in	mm in	mm in
50 1.969	50 1.969	62 2.441	35 1.378	50 1.969	70 2.756	14 0.551	10 0.394	0.6 0.024
	50 1.969	62 2.441	35 1.378	50 1.969	71.5 2.815	14 0.551	10 0.394	0.6 0.024
60 2.362	60 2.362	72 2.835	40 1.575	60 2.362	85 3.346	17 0.669	12 0.472	1 0.039
70 2.756	70 2.756	85 3.346	40 1.575	70 2.756	95 3.740	18 0.709	11 0.433	1 0.039

Bearing Designation	Speed Rating Oil	Load Ratings				Wt.	Matching Inner ring Designation	Shaft Diameter
		Radial		Thrust				
		Dynamic	Static	Dynamic	Static			
		C	C ₀	C	C ₀			
	min ⁻¹	kN lbf		kN lbf		kg	mm in	
NAXK50	4300	30.2 6790	68.5 15400	29.9 6720	75.5 16970	0.316	JR45x50x25	50 1.969
NAXK50Z	4300	30.2 6790	68.5 15400	29.9 6720	75.5 16970	0.332	JR45x50x25	
NAXK60	3600	31.9 7170	78.1 17560	43 9670	113 25400	0.48	JR50x60x25	60 2.362
NAXK70	3400	43.6 9800	87.9 19760	41.6 9350	110 24730	0.659	JR60x70x25	70 2.756



CYLINDRICAL ROLLER THRUST SERIES
METRIC SERIES

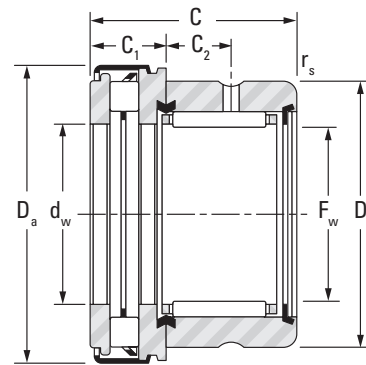

RAXZ 500

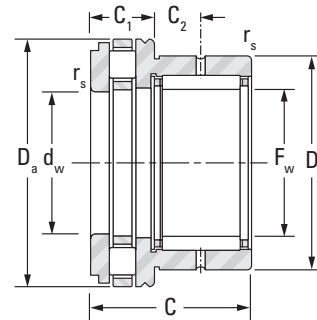

NAXR

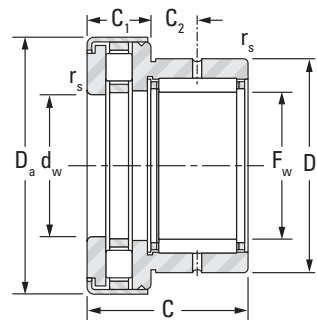

NAXR.Z

Shaft Diameter	F _w	D	C	d _w	D _a	C ₁	C ₂	r _{s min}
				E7				
mm in	mm in	mm in	mm in	mm in	mm in	mm in	mm in	mm in
10 0.394	10 0.394	19 0.748	21.5 0.846	10 0.394	22.4 0.882	7.5 0.295	6 0.236	0.35 0.014
12 0.472	12 0.472	21 0.827	22 0.866	12 0.472	26.4 1.039	8 0.315	6 0.236	0.35 0.014
15 0.591	15 0.591	24 0.945	23 0.906	15 0.591	28 1.102	9 0.354	6.5 0.256	0.3 0.012
	15 0.591	24 0.945	23 0.906	15 0.591	29 1.142	9 0.354	6.5 0.256	0.3 0.012
	15 0.591	24 0.945	22 0.866	15 0.591	28.4 1.118	8 0.315	6 0.236	0.35 0.014
17 0.669	17 0.669	26 1.024	25 0.984	17 0.669	30 1.181	9 0.354	8.0 0.315	0.3 0.012
	17 0.669	26 1.024	25 0.984	17 0.669	31 1.220	9 0.354	8.0 0.315	0.3 0.012
	17 0.669	26 1.024	24 0.945	17 0.669	30.4 1.197	8 0.315	8 0.315	0.65 0.026
20 0.787	20 0.787	30 1.181	30 1.181	20 0.787	35 1.378	10 0.394	10.5 0.413	0.3 0.012
	20 0.787	30 1.181	30 1.181	20 0.787	36 1.417	10 0.394	10.5 0.413	0.3 0.012
	20 0.787	30 1.181	29 1.142	20 0.787	35.4 1.394	11 0.433	9 0.354	0.85 0.033
25 0.984	25 0.984	37 1.457	30 1.181	25 0.984	42 1.654	11 0.433	9.5 0.374	0.6 0.024
	25 0.984	37 1.457	30 1.181	25 0.984	43 1.693	11 0.433	9.5 0.374	0.6 0.024
	25 0.984	37 1.457	29 1.142	25 0.984	43 1.693	11 0.433	9 0.354	0.85 0.033
30 1.181	30 1.181	42 1.654	30 1.181	30 1.181	47 1.850	11 0.433	9.5 0.374	0.6 0.024
	30 1.181	42 1.654	30 1.181	30 1.181	48 1.890	11 0.433	9.5 0.374	0.6 0.024
	30 1.181	42 1.654	29 1.142	30 1.181	48 1.890	11 0.433	9 0.354	0.85 0.033
35 1.378	35 1.378	47 1.850	30 1.181	35 1.378	52 2.047	12 0.472	9.0 0.354	0.6 0.024
	35 1.378	47 1.850	30 1.181	35 1.378	53 2.087	12 0.472	9.0 0.354	0.6 0.024
	35 1.378	47 1.850	30 1.181	35 1.378	54 2.126	12 0.472	9 0.354	0.85 0.033

Bearing Designation			Speed Rating	Load Ratings				Wt.	Matching Inner Ring Designation	Shaft Diameter
				Radial		Thrust				
RAXZ	NAXR	NAXR.Z	min ⁻¹	Dynamic	Static	Dynamic	Static	kg lbs		mm in
				C	C ₀	C	C ₀			
			kN lbf		kN lbf					
RAXZ 510			15500	5.9 1330	7.2 1610	8.2 1840	17.9 4020	0.026 0.057	IM 7 10 16 P	10 0.394
RAXZ 512			13000	6.8 1520	9.0 2030	12.7 2860	29.5 6630	0.033 0.073	IM 9 12 16 P	12 0.472
	NAXR15		12000	9.7 2180	12.6 2830	12.1 2720	26.3 5910	0.032 0.071	JR12x15x16	15 0.591
		NAXR15.Z	12000	9.7 2180	12.6 2830	12.1 2720	26.3 5910	0.035 0.077	JR12x15x16	
RAXZ 515			11500	9.7 2170	12.6 2830	14.0 3150	34.0 7640	0.036 0.079	IM 12 15 16 P	
	NAXR17		11000	11.4 2560	16.1 3620	12.6 2830	28.6 6430	0.050 0.110	JR14x17x17	17 0.669
		NAXR17.Z	11000	11.4 2560	16.1 3620	12.6 2830	28.6 6430	0.053 0.117	JR14x17x17	
RAXZ 517			10500	11.8 2650	16.3 3660	15.0 3370	39.0 8770	0.044 0.097	IM 14 17 17 P	
	NAXR20TN		9500	14.8 3330	23.7 5330	23.6 5310	56.8 12800	0.090 0.198	JR17x20x20	20 0.787
		NAXR20Z.TN	9500	14.8 3330	23.7 5330	23.6 5310	56.8 12800	0.095 0.209	JR17x20x20	
RAXZ 520			9000	14.8 3330	23.7 5330	22.0 4950	54.0 12100	0.070 0.154	IM 15 20 20 P	
	NAXR25TN		8000	18.8 4230	29.8 6700	31.2 7010	81.0 18200	0.146 0.322	JR20x25x20	25 0.984
		NAXR25Z.TN	8000	18.8 4230	29.8 6700	31.2 7010	81.0 18200	0.152 0.335	JR20x25x20	
RAXZ 525			7500	15.1 3390	26.2 5890	25.5 5730	70.0 15700	0.105 0.231	IM 20 25 20 P	
	NAXR30TN		6700	20.2 4540	34.6 7780	33.0 7420	91.1 20500	0.162 0.357	JR25x30x20	30 1.181
		NAXR30Z.TN	6700	20.2 4540	34.6 7780	33.0 7420	91.1 20500	0.169 0.373	JR25x30x20	
RAXZ 530			6500	20.2 4540	34.6 7780	26.5 5960	77.0 17300	0.118 0.260	IM 25 30 20 P	
	NAXR35		6000	22.1 4970	40.8 9170	30.9 6950	86.0 19300	0.186 0.410	JR30x35x20	35 1.378
		NAXR35.Z	6000	22.1 4970	40.8 9170	30.9 6950	86.0 19300	0.195 0.430	JR30x35x20	
RAXZ 535			5500	22.1 4970	40.8 9170	33.8 7600	94.0 21100	0.146 0.322	IM 30 35 20 P	

Continued on next page.



CYLINDRICAL ROLLER THRUST SERIES – continued
METRIC SERIES

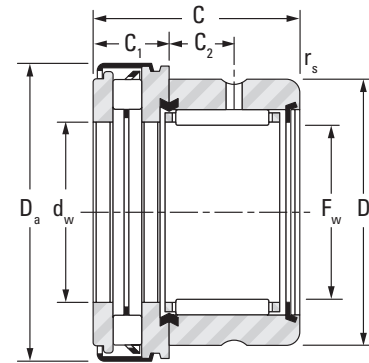

RAXZ 500

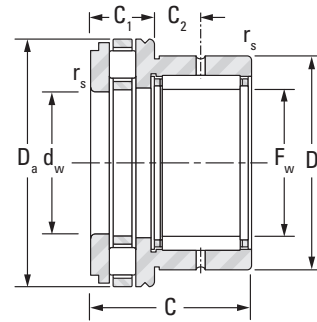

NAXR

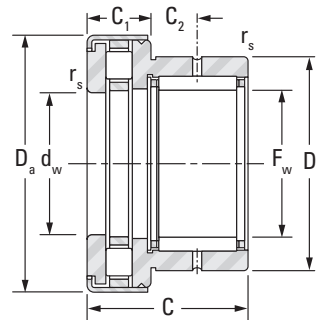

NAXR.Z

Shaft Diameter	F _w	D	C	d _w	D _a	C ₁	C ₂	r _{s min}
				E7				
mm in	mm in	mm in	mm in	mm in	mm in	mm in	mm in	mm in
40 1.575	40 1.575	52 2.047	32 1.260	40 1.575	60 2.362	13 0.512	10.0 0.394	0.6 0.024
	40 1.575	52 2.047	32 1.260	40 1.575	61 2.402	13 0.512	10.0 0.394	0.6 0.024
	40 1.575	52 2.047	31 1.220	40 1.575	61 2.402	13 0.512	9 0.354	0.85 0.033
45 1.772	45 1.772	58 2.283	32 1.260	45 1.772	65 2.559	14 0.551	9.0 0.354	0.6 0.024
	45 1.772	58 2.283	32 1.260	45 1.772	66 2.598	14 0.551	9.0 0.354	0.6 0.024
	45 1.772	58 2.283	31 1.220	45 1.772	66 2.598	13 0.512	9 0.354	0.85 0.033
50 1.969	50 1.969	62 2.441	35 1.378	50 1.969	70 2.756	14 0.551	10.0 0.394	0.6 0.024
	50 1.969	62 2.441	35 1.378	50 1.969	71 2.795	14 0.551	10.0 0.394	0.6 0.024
	50 1.969	62 2.441	34 1.339	50 1.969	71 2.795	13 0.512	11 0.433	1.3 0.051
60 2.362	60 2.362	72 2.835	36 1.417	60 2.362	86 3.386	15 0.591	11 0.433	1.3 0.051
70 2.756	70 2.756	85 3.346	36 1.417	70 2.756	96 3.780	15 0.591	11 0.433	1.3 0.051

Bearing Designation			Speed Rating	Load Ratings				Wt.	Matching Inner Ring Designation	Shaft Diameter
				Radial		Thrust				
RAXZ	NAXR	NAXR.Z		Dynamic	Static	Dynamic	Static			
			C	C ₀	C	C ₀				
			kN lbf		kN lbf		kg lbs			
	NAXR40		5300	23.8 5350	47.0 10600	44.5 10000	126.0 28300	0.288 0.635	JR35x40x20	40 1.575
		NAXR40.Z	5300	23.8 5350	47.0 10600	44.5 10000	126.0 28300	0.299 0.659	JR35x40x20	
RAXZ 540			5000	23.8 5350	47.0 10600	46.0 10300	129.0 29000	0.174 0.384	IM 35 40 20 P	
	NAXR45TN		4800	24.9 5600	51.8 11600	47.0 10600	140.0 31500	0.360 0.794	JR40x45x20	45 1.772
		NAXR45Z.TN	4800	24.9 5600	51.8 11600	47.0 10600	140.0 31500	0.370 0.816	JR40x45x20	
RAXZ 545			4500	24.9 5600	51.8 11600	49.0 11000	143.0 32100	0.206 0.454	IM 40 45 20 P	
	NAXR50		4300	30.2 6790	68.5 15400	49.7 11200	155.0 34800	0.432 0.952	JR45x50x25	50 1.969
		NAXR50.Z	4300	30.2 6790	68.5 15400	49.7 11200	155.0 34800	0.452 0.996	JR45x50x25	
RAXZ 550			4000	30.2 6790	68.5 15400	51.0 11500	157.0 35300	0.232 0.511	IM 45 50 25 P	
RAXZ 560			3500	31.9 7170	78.1 17600	71.0 16000	255.0 57300	0.327 0.721	IM 55 60 25 P	60 2.362
RAXZ 570			3000	36.1 8120	84.7 19000	77.0 17300	295.0 66300	0.435 0.959	IM 60 70 25 P	70 2.756



**NEEDLE ROLLER AND CYLINDRICAL ROLLER THRUST SERIES
METRIC SERIES**

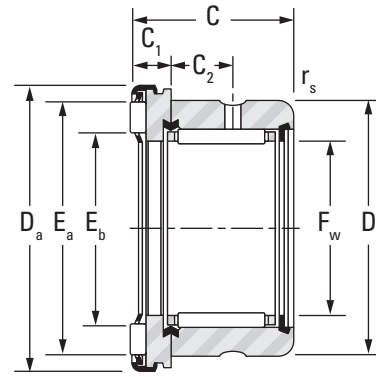

RAX 400

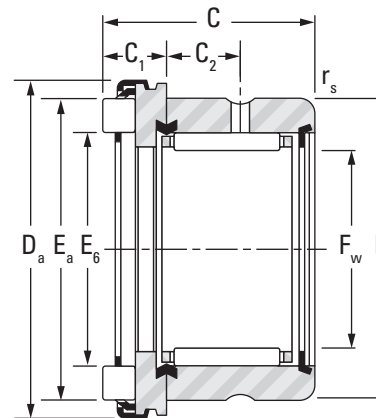

RAX 500

Shaft Diameter	F _w	C	D	D _a	E _b	E _a	C ₁	C ₂	r _{s min}
10 0.3937	10 0.3937	19 0.748	19 0.7480	22 0.8661	12 0.47	18.6 0.73	5 0.197	6 0.236	0.35 0.014
	10 0.3937	19.5 0.768	19 0.7480	22 0.8661	12.2 0.48	18.5 0.73	5.5 0.217	6 0.236	0.35 0.014
12 0.4724	12 0.4724	19 0.748	21 0.8268	26 1.0236	15 0.59	22.6 0.89	5 0.197	6 0.236	0.35 0.014
	15 0.5906	19 0.748	24 0.9449	28 1.1024	17 0.67	24.6 0.97	5 0.197	6 0.236	0.35 0.014
	15 0.5906	20 0.787	24 0.9449	28 1.1024	16.8 0.66	24.9 0.98	6 0.236	6 0.236	0.35 0.014
17 0.6693	17 0.6693	21 0.827	26 1.0236	30 1.1811	19 0.75	26.6 1.05	5 0.197	8 0.315	0.65 0.026
	17 0.6693	22 0.866	26 1.0236	30 1.1811	18.8 0.74	26.9 1.06	6 0.236	8 0.315	0.65 0.026
20 0.7874	20 0.7874	24 0.945	30 1.1811	35 1.3780	22 0.87	31.6 1.24	6 0.236	9 0.354	0.85 0.033
	20 0.7874	26 1.024	30 1.1811	35 1.3780	22 0.87	31.6 1.24	8 0.315	9 0.354	0.85 0.033
25 0.9843	25 0.9843	24 0.945	37 1.4567	42 1.6535	27.7 1.09	37.4 1.47	6 0.236	9 0.354	0.85 0.033
	25 0.9843	26 1.024	37 1.4567	42 1.6535	27.7 1.09	37.4 1.47	8 0.315	9 0.354	0.85 0.033
30 1.1811	30 1.1811	24 0.945	42 1.6535	47 1.8504	32.7 1.29	42.4 1.67	6 0.236	9 0.354	0.85 0.033
	30 1.1811	26 1.024	42 1.6535	47 1.8504	32.7 1.29	42.3 1.67	8 0.315	9 0.354	0.85 0.033
35 1.3780	35 1.3780	24 0.945	47 1.8504	53 2.0866	37.2 1.46	49 1.93	6 0.236	9 0.354	0.85 0.033
	35 1.3780	27 1.063	47 1.8504	53.4 2.1024	37.8 1.49	47.8 1.88	9 0.354	9 0.354	0.85 0.033
40 1.5748	40 1.5748	24 0.945	52 2.0472	60 2.3622	43 1.69	54.9 2.16	6 0.236	9 0.354	0.85 0.033
45 1.7717	45 1.7717	24 0.945	58 2.2835	65 2.5591	48 1.89	59.9 2.36	6 0.236	9 0.354	0.85 0.033
	45 1.7717	28 1.102	58 2.2835	65.4 2.5748	47.8 1.88	59.8 2.35	10 0.394	9 0.354	0.85 0.033

Bearing Designation		Speed Rating	Load Ratings				Wt.	Matching Inner Ring	Thin Plate	Thick Plate	Shaft Diameter
			Radial		Thrust						
			Dynamic	Static	Dynamic	Static					
400 Series	500 Series	min ⁻¹	C	C ₀	C	C ₀	kg lbs				mm in
RAX 410		15500	5.90 1330	7.16 1610	5.00 1120	10.9 2450	0.025 0.055		CP 10 22	CP 2 10 22	10 0.3937
	RAX 510	15500	5.90 1330	7.16 1610	8.20 1840	17.9 4020	0.026 0.057		CP 10 22	CP 2 10 22	
RAX 412		13000	6.78 1520	9.03 2030	7.10 1600	18.5 4160	0.032 0.071	IM 9 12 16 P	CP 12 26	CP 2 12 26	12 0.4724
RAX 415		11500	9.66 2170	12.6 2830	7.60 1710	20.8 4680	0.034 0.075	IM 12 15 16 P	CP 15 28	CP 2 15 28	15 0.5906
	RAX 515	11500	9.66 2170	12.6 2830	14.0 3150	34.0 7640	0.036 0.079	IM 12 15 16 P	CP 15 28	CP 2 15 28	
RAX 417		10500	11.8 2650	16.3 3660	8.10 1820	23.0 5170	0.041 0.090	IM 14 17 17 P	CP 17 30	CP 2 17 30	17 0.6693
	RAX 517	10500	11.8 2650	16.3 3660	15.0 3370	39.0 8770	0.044 0.097	IM 14 17 17 P	CP 17 30	CP 2 17 30	
RAX 420		9000	14.8 3330	23.7 5330	11.8 2650	39.0 8770	0.066 0.146	IM 15 20 20 P	CP 20 35	CP 3 20 35	20 0.7874
	RAX 520	9000	14.8 3330	23.7 5330	22.0 4950	54.0 12100	0.070 0.154	IM 15 20 20 P	CP 20 35	CP 3 20 35	
RAX 425		7500	15.1 3390	26.2 5890	13.3 2990	49.0 11000	0.099 0.218	IM 20 25 20 P	CP 25 42	CP 3 25 42	25 0.9843
	RAX 525	7500	15.1 3390	26.2 5890	25.5 5730	70.0 15700	0.105 0.231	IM 20 25 20 P	CP 25 42	CP 3 25 42	
RAX 430		6500	20.2 4540	34.6 7780	14.5 3260	57.0 12800	0.111 0.245	IM 25 30 20 P	CP 30 47	CP 3 30 47	30 1.1811
	RAX 530	6500	20.2 4540	34.6 7780	26.5 5960	77.0 17300	0.118 0.260	IM 25 30 20 P	CP 30 47	CP 3 30 47	
RAX 435		5500	22.1 4970	40.8 9170	18.9 4250	84.0 18900	0.130 0.287	IM 30 35 20 P	CP 35 52	CP 3 35 52	35 1.3780
	RAX 535	5500	22.1 4970	40.8 9170	33.8 7600	94.0 21100	0.146 0.322	IM 30 35 20 P	CP 35 52	CP 3 35 52	
RAX 440		5000	23.8 5350	47.0 10600	20.4 4590	96.0 21600	0.150 0.331	IM 35 40 20 P	CP 40 60	CP 3 40 60	40 1.5748
RAX 445		4500	24.9 5600	51.8 11600	21.8 4900	109.0 24500	0.179 0.395	IM 40 45 20 P	CP 45 65	CP 3 45 65	45 1.7717
	RAX 545	4500	24.9 5600	51.8 11600	49.0 11000	143.0 32100	0.206 0.454	IM 40 45 20 P	CP 45 65	CP 3 45 65	

Continued on next page.



NEEDLE ROLLER AND CYLINDRICAL ROLLER THRUST SERIES – continued
METRIC SERIES

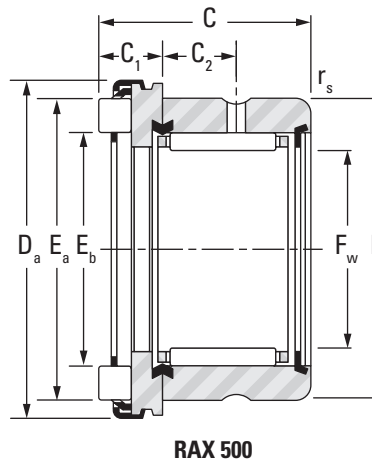
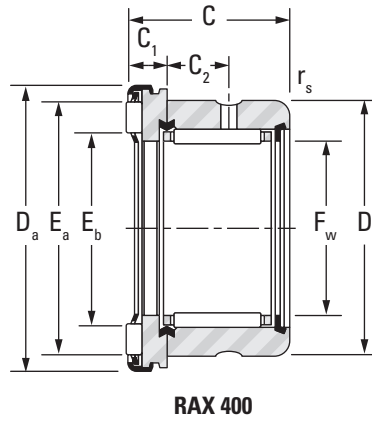

Shaft Diameter	F _w	C	D	D _a	E _b	E _a	C ₁	C ₂	r _{s min}
mm in	mm in	mm in	mm in	mm in	mm in	mm in	mm in	mm in	mm in
50 1.9685	50 1.9685	27 1.063	62 2.4409	70 2.7559	53.3 2.10	65.7 2.59	6 0.236	11 0.433	1.3 0.051
	50 1.9685	31 1.220	62 2.4409	70.4 2.7717	52.8 2.08	64.8 2.55	10 0.394	11 0.433	1.3 0.051
60 2.3622	60 2.3622	28 1.102	72 2.8346	85 3.3465	63.5 2.50	79.2 3.12	7 0.276	11 0.433	1.3 0.051
	60 2.3622	32 1.260	72 2.8346	85.4 3.3622	63.5 2.50	79.5 3.13	11 0.433	11 0.433	1.3 0.051
70 2.7559	70 2.7559	28 1.102	85 3.3465	95 3.7402	73.5 2.89	89.2 3.51	7 0.276	11 0.433	1.3 0.051
	70 2.7559	32 1.260	85 3.3465	95.4 3.7559	73.5 2.89	89.5 3.52	11 0.433	11 0.433	1.3 0.051

Bearing Designation		Speed Rating	Load Ratings				Wt.	Matching Inner Ring	Thin Plate	Thick Plate	Shaft Diameter
			Radial		Thrust						
400 Series	500 Series		Dynamic	Static	Dynamic	Static					
		min ⁻¹	kN lbf		kN lbf						
RAX 450		4000	30.2 6790	68.5 15400	22.5 5060	118.0 26500	0.205 0.452	IM 45 50 25 P	CP 50 70	CP 3 50 70	50 1.9685
	RAX 550	4000	30.2 6790	68.5 15400	51.0 11500	157.0 35300	0.232 0.511	IM 45 50 25 P	CP 50 70	CP 3 50 70	
RAX 460		3500	31.9 7170	78.1 17600	31.5 7080	193.0 43400	0.282 0.622	IM 55 60 25 P	CP 60 85	CP 4 60 85	60 2.3622
	RAX 560	3500	31.9 7170	78.1 17600	71.0 16000	255.0 57300	0.327 0.721	IM 55 60 25 P	CP 60 85	CP 4 60 85	
RAX 470		3000	36.1 8120	84.7 19000	34.5 7760	223.0 50100	0.386 0.851	IM 60 70 25 P	CP 1,5 70 95	CP 4 70 95	70 2.7559
	RAX 570	3000	36.1 8120	84.7 19000	77.0 17300	295.0 66300	0.435 0.959	IM 60 70 25 P	CP 1,5 70 95	CP 4 70 95	



DRAWN CUP, NEEDLE ROLLER THRUST SERIES OPEN AND CLOSED BEARINGS
METRIC SERIES

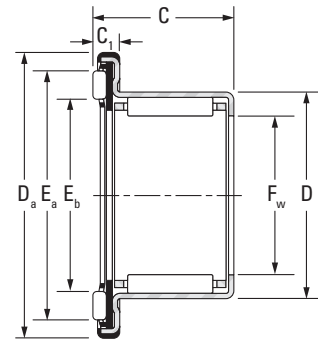

RAX 700

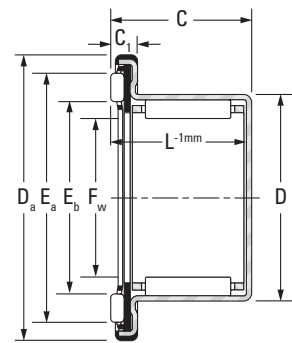

RAXF 700

Shaft Diameter	F _w	D	C	D _a	E _b	E _a	C ₁	Bearing Designation	
								Open-Ends	Closed-End
mm in	mm in	mm in	mm in	mm in	mm in	mm in	mm in		
5 0.1969	5 0.1969	9 0.3543	11 0.433	15.5 0.6102	7.2 0.28	11.2 0.44	3.3 0.130	RAX 705	
12 0.4724	12 0.4724	18 0.7087	14.2 0.559	27.5 1.0827	15 0.59	22.6 0.89	4.2 0.165	RAX 712	RAXF 712
14 0.5512	14 0.5512	20 0.7874	14.2 0.559	29.5 1.1614	17 0.67	24.6 0.97	4.2 0.165	RAX 714	RAXF 714
15 0.5906	15 0.5906	21 0.8268	14.2 0.559	31.5 1.2402	19 0.75	26.6 1.05	4.2 0.165	RAX 715	RAXF 715
18 0.7087	18 0.7087	24 0.9449	18.2 0.717	33.5 1.3189	21 0.83	28.6 1.13	4.2 0.165	RAX 718	RAXF 718
20 0.7874	20 0.7874	26 1.0236	18.2 0.717	36.5 1.4370	22 0.87	31.6 1.24	4.2 0.165	RAX 720	RAXF 720
25 0.9843	25 0.9843	33 1.2992	22.2 0.874	45.5 1.7913	30 1.18	39.6 1.56	4.2 0.165	RAX 725	RAXF 725
30 1.1811	30 1.1811	38 1.4961	22.2 0.874	50.5 1.9882	35 1.38	44.7 1.76	4.2 0.165	RAX 730	RAXF 730
35 1.3780	35 1.3780	43 1.6929	22.2 0.874	56.5 2.2244	39 1.54	50.9 2.00	4.2 0.165	RAX 735	
40 1.5748	40 1.5748	48 1.8898	22.2 0.874	61.5 2.4213	43 1.69	54.9 2.16	4.2 0.165	RAX 7309	RAXF 7309
45 1.7717	45 1.7717	52 2.0472	22.2 0.874	66.5 2.6181	48 1.89	59.9 2.36	4.2 0.165	RAX 745	

L ⁻¹	Speed Rating	Load Ratings				Wt.	Inspection			Matching Inner Ring	Thin Plate	Thick Plate	Shaft Diameter
		Radial		Thrust			Ring Gage	Go Plug	No Go Plug				
		Dynamic	Static	Dynamic	Static								
mm in	min ⁻¹	C	C ₀	C	C ₀	mm in	mm in	mm in				mm in	
-	25000	2.15 480	1.95 440	3.15 710	6.35 1430	0.005 0.010	9.000 0.3543	5.009 0.1972	5.036 0.1983				
13.2 0.520	13000	6.30 1420	7.20 1620	6.90 1550	17.7 3980	0.017 0.036	18.000 0.7087	12.009 0.4728	12.035 0.4738	IM 8 12 12,4	CP 12 26	CP 2 12 26	12 0.4724
13.2 0.520	11500	6.90 1550	8.50 1910	7.40 1660	20.0 4500	0.018 0.040	20.000 0.7874	14.009 0.5515	14.035 0.5526	IM 10 14 12,4	CP 14 26	CP 2 14 26	14 0.5512
13.2 0.520	10500	7.40 1660	9.30 2090	7.80 1750	22.0 4950	0.020 0.044	21.000 0.8268	15.009 0.5909	15.035 0.5919	IM 12 15 12,4	CP 15 28	CP 2 15 28	15 0.5906
17.2 0.677	10000	11.5 2590	17.7 3980	8.00 1800	23.0 5170	0.027 0.060	24.000 0.9449	18.009 0.7090	18.035 0.7100	IM 13 18 16,4	CP 18 30	CP 2 18 30	18 0.7087
17.2 0.677	9000	12.2 2740	19.5 4380	11.8 2650	39.0 8770	0.031 0.068	26.000 1.0236	20.009 0.7878	20.035 0.7888	IM 15 20 16,4	CP 20 35	CP 3 20 35	20 0.7874
21.2 0.835	7200	20.5 4610	32.0 7190	13.7 3080	52.0 11700	0.055 0.121	33.000 1.2992	20.015 0.7880	25.041 0.9859	IM 20 25 20,4	CP 25 42	CP 3 25 42	25 0.9843
21.2 0.835	6300	22.3 5010	37.5 8430	14.9 3350	60.0 13500	0.063 0.139	38.000 1.4961	30.015 1.1817	30.041 1.1827	IM 25 30 20,4	CP 30 47	CP 3 30 47	30 1.1811
21.2 0.835	5500	24.5 5510	45.0 10120	19.4 4360	88.0 19800	0.075 0.165	43.000 1.6929	35.015 1.3785	35.041 1.3796	IM 30 35 20,4	CP 35 52	CP 3 35 52	35 1.3780
21.2 0.835	5000	26.2 5890	51.0 11470	20.4 4590	96.0 21600	0.086 0.190	48.000 1.8898	40.015 1.5754	40.041 1.5764	IM 35 40 20,4	CP 40 60	CP 3 40 60	40 1.5748
21.2 0.835	4500	24.8 5580	55.0 12360	21.8 4900	109 24500	0.088 0.194	52.000 2.0472	45.015 1.7722	45.041 1.7733	IM 40 45 20,4	CP 45 65	CP 3 45 65	45 1.7717



NEEDLE ROLLERS, ACCESSORIES NEEDLE/CYLINDRICAL ROLLERS

Overview: Loose needle and cylindrical rollers are mainly used as bearing rolling elements to reduce friction and torque in rotating and pivoting applications. However, these precision rollers have many other uses, such as shafts or locating pins.

- **Sizes:** Diameters from 1 mm (0.0394 in) to 15 mm (0.5906 in). Lengths from 2.5 mm (0.0984 in) to 69 mm (2.7165 in).
- **Markets:** Vehicle and industrial transmissions, universal joints, and two-cycle engines.
- **Features:** Cylindrical and needle sizes are available. Needle rollers are available with flat and rounded-ends; metric series needle rollers available in Grade 2, 3 or 5.
- **Benefits:** Provide the maximum load-carrying capacity, within the smallest envelope, at a low cost.

METRIC INNER RINGS

Overview: Inner rings are made from bearing-quality steel, and their O.D. and bore are precision-ground. They function as the inner raceway for a needle roller bearing by providing a surface that meets all shaft raceway design requirements (hardness, surface finish, roundness, etc.).

- **Sizes:** 5 mm (0.1969 in) bore to 180 mm (7.0866 in) outer diameter.
- **Markets:** Automotive, truck, power transmissions, and industrial applications.
- **Features:** Available with and without chamfers, some are available with a profiled outer diameter.
- **Benefits:** When it is not practical to manufacture the shaft to raceway quality, an inner ring allows a customer to obtain acceptable bearing performance.



Standard Inner Rings for Needle Roller Bearings – Metric Nominal Dimensions

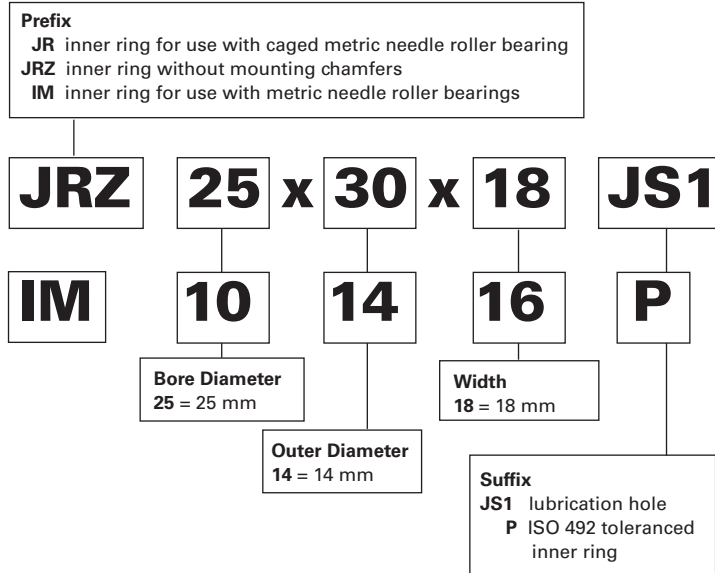

Extra Wide Inner Rings for Needle Roller Bearings – Metric Nominal Dimensions

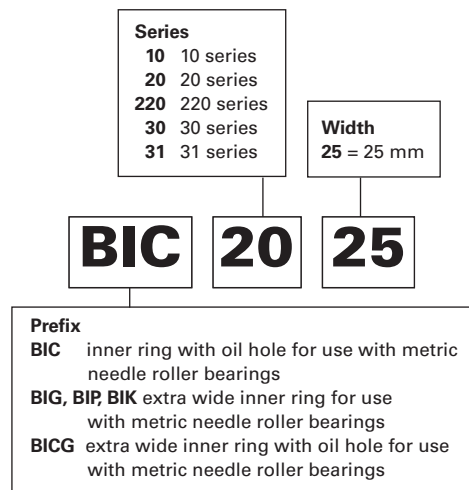

Inner Rings for Full Complement Needle Roller Bearings – Metric Nominal Dimensions

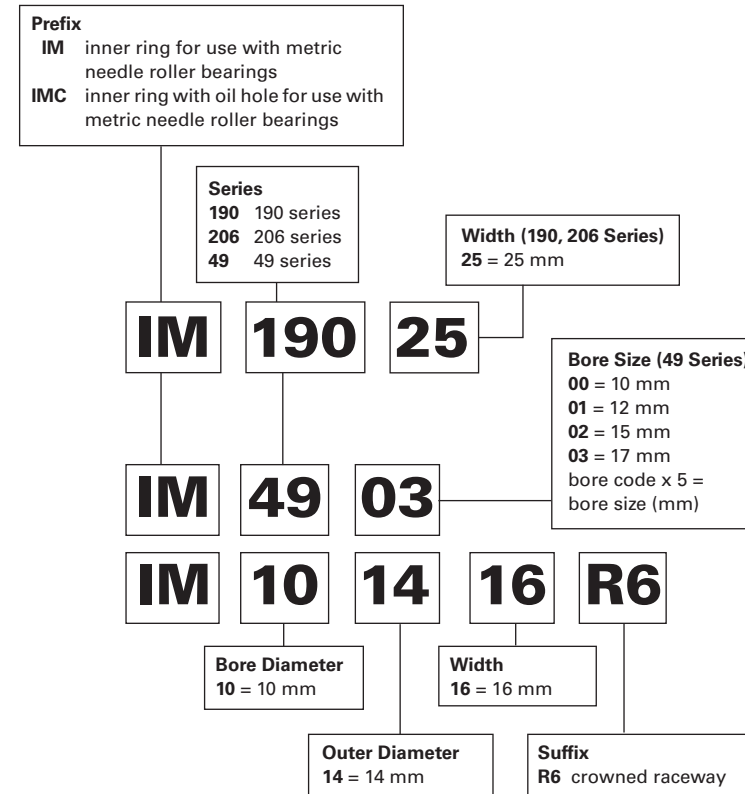

Loose Rollers – Metric Nominal Dimensions

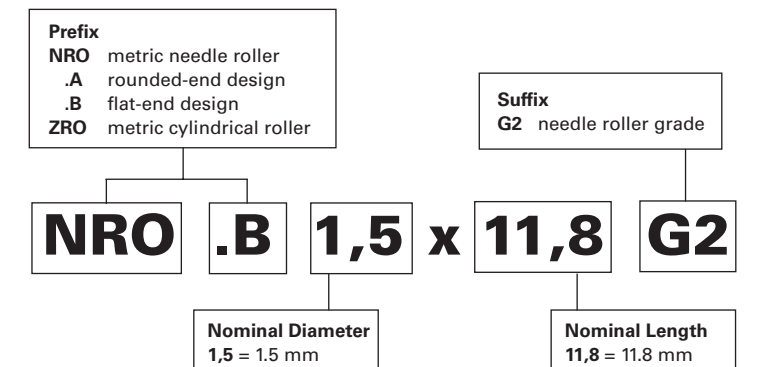



Needle Rollers, Accessories

	<i>Page</i>
Introduction – Needle Rollers – Metric Series	B-352
Introduction – Needle Rollers – Inch Series	B-360
Introduction – Cylindrical Rollers – Metric Series	B-365
Inner Rings – Metric Series	B-367
Inner Rings for Full Complement Drawn Cup Needle Roller Bearings – Metric Series	B-378
Inner Rings for Machine – Tool Quality Precision – Combined Bearings – Metric Series	B-381
Inner Rings with Oil Holes/Extra Wide, RNA Bearings.	B-382
End Washers – Metric Series	B-385





NEEDLE ROLLERS – METRIC SERIES

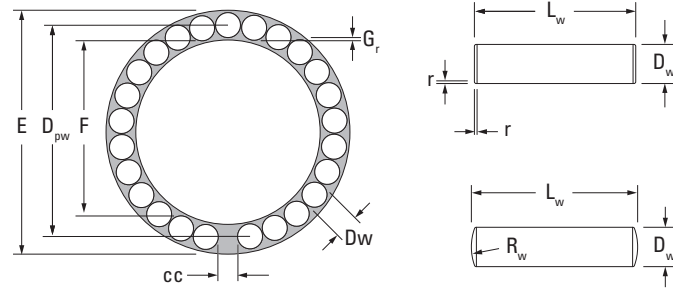
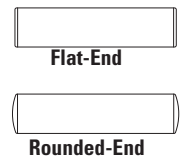

Fig. B-80. Metric Series needle rollers

Needle rollers are made from rolling bearing-quality steel, hardened to 60-64 HRC or equivalent. Nominal metric needle rollers in various grades are standardized at national and international levels. The grades determine the dimensional and form tolerances of the needle rollers. Metric series needle rollers may differ by their end form: type A has rounded-end and type B has flat-ends. JTEKT prefers to supply needle roller in the most economical flat-end, or type B design, in G2 grade. Metric series needle rollers of type A also may be made available on request and in other G3 or G5 grades.

METRIC SERIES NEEDLE ROLLER DIMENSIONS

Nominally metric needle rollers, conforming to the International Standard ISO 3096, are shown in Table B-60 on page B-354. The symbols used in Table B-60 on page B-354, as well as in subsequent tables and figures, are summarized in Table B-63 on page B-356. Needle rollers with flat-ends, which are the preferred design, are shown in Table B-60 on page B-354. Chamfer dimension limits are also shown, the use of which results in the maximum possible effective contact length between roller and raceway. Yet, the relief at the needle roller ends help to reduce stress concentration – resulting in more uniform stress distribution, optimum load ratings, and longer life.

Every needle roller gage is separately packed, and packages are marked accordingly.

REFERENCE STANDARDS ARE:

- ISO 3096 – rolling bearings – needle rollers – dimensions and tolerances.
• DIN 5402 – rolling bearing components – needle rollers.

EXAMPLE OF METRIC SERIES NEEDLE ROLLER DESIGNATION AND PACKAGE MARKING:

NRO.B1,5x13,8G2
M2M4

- NRO – Needle roller
.B – Flat-end needle rollers
1,5 – Nominal diameter Dw = 1.500 mm
13,8 – Nominal length Lw = 13.800 mm
G2 – Needle roller grade (see Table B-59 on page B-355.)
M2M4 – Deviation of needle roller gage -2.000/-4.000 µm

The actual finished diameter is between 1.498 and 1.496 mm.

In the marking of the needle roller gage, P identifies zero (0) or plus (+), and M identifies minus (-). If a shipment of needle rollers of the same size comprises several boxes, each box contains needle rollers of the same grade. The gage may vary from box to box. Each individual box, however, contains needle rollers of the particular gage identified on the box.

METRIC SERIES NEEDLE ROLLER TOLERANCES

Table B-59. Variation of Gage Lot Diameter, Preferred Gages and Circularity Deviation (values in µm)

Table with 4 main columns: Grade, Variation of Gage Lot Diameter V_DwL Max., Gages High/Low Deviation of Mean Diameter D_wmp, and Circularity Deviation Max. It contains data for grades 2, 3, and 5.

Note 1 - Tolerance values apply only at the middle of the needle roller length.

Note 2 - Needle rollers of any nominal dimensions and any of the quoted grades will be supplied sub-divided into the gages listed in Table B-59 at our option, if nothing to the contrary is agreed upon at the time of ordering.



Table B-60. Dimensions of metric series needle rollers

Dia.	Length	Needle Roller Designation	Wt. 1000 pcs Approx.	r _s min Chamfer Dimension Limits			Dia.	Length	Needle Roller Designation	Wt. 1000 pcs Approx.	r _s min Chamfer Dimension Limits		
				mm in	mm in	mm in					mm in	mm in	mm in
1.5 0.0591	5.8 0.228	NRO.B1.5x5,8G2	0.080 0.176	0.1 0.004	0.4 0.016	0.6 0.024	3.5 0.1378	11.8 0.465	NRO.B3.5x11,8G2	0.910 2.006	0.1 0.004	0.9 0.035	1.0 0.039
1.5 0.0591	6.8 0.268	NRO.B1.5x6,8G2	0.094 0.207	0.1 0.004	0.4 0.016	0.6 0.024	3.5 0.1378	13.8 0.543	NRO.B3.5x13,8G2	1.040 2.293	0.1 0.004	0.9 0.035	1.0 0.039
1.5 0.0591	7.8 0.307	NRO.B1.5x7,8G2	0.108 0.238	0.1 0.004	0.4 0.016	0.6 0.024	3.5 0.1378	15.8 0.622	NRO.B3.5x15,8G2	1.190 2.624	0.1 0.004	0.9 0.035	1.0 0.039
1.5 0.0591	9.8 0.386	NRO.B1.5x9,8G2	0.136 0.300	0.1 0.004	0.4 0.016	0.6 0.024	3.5 0.1378	17.8 0.701	NRO.B3.5x17,8G2	1.340 2.954	0.1 0.004	0.9 0.035	1.0 0.039
1.5 0.0591	11.8 0.465	NRO.B1.5x11,8G2	0.164 0.362	0.1 0.004	0.4 0.016	0.6 0.024	3.5 0.1378	21.8 0.858	NRO.B3.5x21,8G2	1.640 3.616	0.1 0.004	0.9 0.035	1.0 0.039
1.5 0.0591	13.8 0.543	NRO.B1.5x13,8G2	0.191 0.421	0.1 0.004	0.4 0.016	0.6 0.024	3.5 0.1378	23.8 0.937	NRO.B3.5x23,8G2	1.850 4.079	0.1 0.004	0.9 0.035	1.0 0.039
2 0.0787	7.8 0.307	NRO.B2x7,8G2	0.190 0.419	0.1 0.004	0.6 0.024	0.8 0.031	3.5 0.1378	25.8 1.016	NRO.B3.5x25,8G2	1.950 4.299	0.1 0.004	0.9 0.035	1.0 0.039
2 0.0787	9.8 0.386	NRO.B2x9,8G2	0.240 0.529	0.1 0.004	0.6 0.024	0.8 0.031	3.5 0.1378	29.8 1.173	NRO.B3.5x29,8G2	2.250 4.960	0.1 0.004	0.9 0.035	1.0 0.039
2 0.0787	11.8 0.465	NRO.B2x11,8G2	0.290 0.639	0.1 0.004	0.6 0.024	0.8 0.031	3.5 0.1378	34.8 1.370	NRO.B3.5x34,8G2	2.650 5.842	0.1 0.004	0.9 0.035	1.0 0.039
2 0.0787	13.8 0.543	NRO.B2x13,8G2	0.340 0.750	0.1 0.004	0.6 0.024	0.8 0.031	4 0.1575	11.8 0.465	NRO.B4x11,8G2	1.600 3.527	0.1 0.004	0.9 0.035	1.0 0.039
2 0.0787	15.8 0.622	NRO.B2x15,8G2	0.390 0.860	0.1 0.004	0.6 0.024	0.8 0.031	4 0.1575	13.8 0.543	NRO.B4x13,8G2	1.360 2.998	0.1 0.004	0.9 0.035	1.0 0.039
2 0.0787	17.8 0.701	NRO.B2x17,8G2	0.440 0.970	0.1 0.004	0.6 0.024	0.8 0.031	4 0.1575	15.8 0.622	NRO.B4x15,8G2	1.550 3.417	0.1 0.004	0.9 0.035	1.0 0.039
2 0.0787	19.8 0.780	NRO.B2x19,8G2	0.490 1.080	0.1 0.004	0.6 0.024	0.8 0.031	4 0.1575	17.8 0.701	NRO.B4x17,8G2	1.750 3.858	0.1 0.004	0.9 0.035	1.0 0.039
2 0.0787	21.8 0.858	NRO.B2x21,8G2	0.540 1.190	0.1 0.004	0.6 0.024	0.8 0.031	4 0.1575	19.8 0.780	NRO.B4x19,8G2	1.950 4.299	0.1 0.004	0.9 0.035	1.0 0.039
2.5 0.0984	7.8 0.307	NRO.B2.5x7,8G2	0.300 0.661	0.1 0.004	0.6 0.024	0.8 0.031	4 0.1575	21.8 0.858	NRO.B4x21,8G2	2.150 4.740	0.1 0.004	0.9 0.035	1.0 0.039
2.5 0.0984	9.8 0.386	NRO.B2.5x9,8G2	0.380 0.838	0.1 0.004	0.6 0.024	0.8 0.031	4 0.1575	23.8 0.937	NRO.B4x23,8G2	2.350 5.181	0.1 0.004	0.9 0.035	1.0 0.039
2.5 0.0984	11.8 0.465	NRO.B2.5x11,8G2	0.450 0.992	0.1 0.004	0.6 0.024	0.8 0.031	4 0.1575	25.8 1.016	NRO.B4x25,8G2	2.550 5.622	0.1 0.004	0.9 0.035	1.0 0.039
2.5 0.0984	13.8 0.543	NRO.B2.5x13,8G2	0.530 1.168	0.1 0.004	0.6 0.024	0.8 0.031	4 0.1575	27.8 1.094	NRO.B4x27,8G2	2.740 6.041	0.1 0.004	0.9 0.035	1.0 0.039
2.5 0.0984	15.8 0.622	NRO.B2.5x15,8G2	0.610 1.345	0.1 0.004	0.6 0.024	0.8 0.031	4 0.1575	29.8 1.173	NRO.B4x29,8G2	2.950 6.504	0.1 0.004	0.9 0.035	1.0 0.039
2.5 0.0984	17.8 0.701	NRO.B2.5x17,8G2	0.690 1.521	0.1 0.004	0.6 0.024	0.8 0.031	4 0.1575	34.8 1.370	NRO.B4x34,8G2	3.400 7.496	0.1 0.004	0.9 0.035	1.0 0.039
2.5 0.0984	19.8 0.780	NRO.B2.5x19,8G2	0.760 1.676	0.1 0.004	0.6 0.024	0.8 0.031	4 0.1575	39.8 1.567	NRO.B4x39,8G2	3.900 8.598	0.1 0.004	0.9 0.035	1.0 0.039
2.5 0.0984	21.8 0.858	NRO.B2.5x21,8G2	0.840 1.852	0.1 0.004	0.6 0.024	0.8 0.031	5 0.1969	15.8 0.622	NRO.B5x15,8G2	2.430 5.357	0.1 0.004	0.9 0.035	1.0 0.039
2.5 0.0984	23.8 0.937	NRO.B2.5x23,8G2	0.920 2.028	0.1 0.004	0.6 0.024	0.8 0.031	5 0.1969	19.8 0.780	NRO.B5x19,8G2	3.050 6.724	0.1 0.004	0.9 0.035	1.0 0.039
3 0.1181	9.8 0.386	NRO.B3x9,8G2	0.540 1.190	0.1 0.004	0.6 0.024	0.8 0.031	5 0.1969	21.8 0.858	NRO.B5x21,8G2	3.360 7.408	0.1 0.004	0.9 0.035	1.0 0.039
3 0.1181	11.8 0.465	NRO.B3x11,8G2	0.650 1.433	0.1 0.004	0.6 0.024	0.8 0.031	5 0.1969	23.8 0.937	NRO.B5x23,8G2	3.670 8.091	0.1 0.004	0.9 0.035	1.0 0.039
3 0.1181	13.8 0.543	NRO.B3x13,8G2	0.760 1.676	0.1 0.004	0.6 0.024	0.8 0.031	5 0.1969	25.8 1.016	NRO.B5x25,8G2	3.980 8.774	0.1 0.004	0.9 0.035	1.0 0.039
3 0.1181	15.8 0.622	NRO.B3x15,8G2	0.870 1.918	0.1 0.004	0.6 0.024	0.8 0.031	5 0.1969	27.8 1.094	NRO.B5x27,8G2	4.290 9.458	0.1 0.004	0.9 0.035	1.0 0.039
3 0.1181	17.8 0.701	NRO.B3x17,8G2	0.990 2.183	0.1 0.004	0.6 0.024	0.8 0.031	5 0.1969	29.8 1.173	NRO.B5x29,8G2	4.600 10.141	0.1 0.004	0.9 0.035	1.0 0.039
3 0.1181	19.8 0.780	NRO.B3x19,8G2	1.100 2.425	0.1 0.004	0.6 0.024	0.8 0.031	5 0.1969	34.8 1.370	NRO.B5x34,8G2	5.400 11.905	0.1 0.004	0.9 0.035	1.0 0.039
3 0.1181	21.8 0.858	NRO.B3x21,8G2	1.210 2.668	0.1 0.004	0.6 0.024	0.8 0.031	5 0.1969	39.8 1.567	NRO.B5x39,8G2	6.150 13.558	0.1 0.004	0.9 0.035	1.0 0.039
3 0.1181	23.8 0.937	NRO.B3x23,8G2	1.320 2.910	0.1 0.004	0.6 0.024	0.8 0.031	5 0.1969	49.8 1.961	NRO.B5x49,8G2	7.500 16.535	0.1 0.004	0.9 0.035	1.0 0.039
3 0.1181	25.8 1.016	NRO.B3x25,8G2	1.430 3.153	0.1 0.004	0.6 0.024	0.8 0.031	6 0.2362	17.8 0.701	NRO.B6x17,8G2	3.950 8.708	0.1 0.004	0.9 0.035	1.0 0.039
3 0.1181	27.8 1.094	NRO.B3x27,8G2	1.540 3.395	0.1 0.004	0.6 0.024	0.8 0.031							

END FORM TOLERANCES

Table B-61 specifies the applicable end configuration for rounded end and flat end needle rollers of all grades.

Table B-61. End configuration limits for metric needle rollers

Rounded End Needle Rollers End Radius		Nominal Diameter of Needle Roller	Flat End Needle Rollers Chamfer Dimension Limits (Dimensions in millimeters)			
R _w (1) Min.	Max.		D _w > <=	r _s min(1)	r _s max Radial Axial	
D _w 2	L _w 2	—	1	0.1	0.3	0.5
		1	1.5	0.1	0.4	0.6
		1.5	3	0.1	0.6	0.8
		3	6	0.1	0.9	1

(1) The chamfer of a needle roller shall clear a fillet radius equal to r_s min, which should also be considered for designs using rounded end needle rollers.

NEEDLE ROLLER LENGTH TOLERANCE

Tolerances on the length L_w for needle rollers of all grades: h13, see Table B-62.

Table B-62. Tolerances for needle roller length, nominal metric needle rollers

Nominal Length, L _w mm		Tolerance Limits mm (ISO h13)	
>	<=	Max.	Min.
3	6	0	-0.18
6	10	0	-0.22
10	18	0	-0.27
18	30	0	-0.33
30	50	0	-0.39

DESIGN CALCULATIONS FOR NEEDLE ROLLER BEARING COMPLEMENTS

In the majority of full complement needle roller applications, needle roller complements of less than 35 needle rollers per row and a ratio of length to diameter between 4:1 and 8:1, is advantageous. Other combinations of quantity and length-to-diameter ratios of needle rollers have been used successfully. Specific design requirements usually dictate the appropriate selection.

In general, needle roller complements for rotating motion should employ a smaller number of large diameter needle rollers, while needle roller complements subjected to oscillating motion (especially under high loads) should employ a large number of smaller diameter needle rollers.

Oscillating applications with small angular travel encourage the development of fretting corrosion. The best performance under these conditions has been achieved by using the largest practical number of small diameter needle rollers.

CALCULATION OF RACEWAY DIAMETERS

The calculation of inner and outer raceway diameters may be carried out using either the formula given in Table B-63 on page B-356 or the raceway calculation form in Table B-64 on page B-356. To assist the designer in making these calculations, the values of K, required for calculation of needle roller complements of six through 60 needle rollers, are listed in Table B-65 on page B-356. Values of K, for other numbers of needle rollers, can be calculated using the formulas given in Table B-63 on page B-356.

Table B-66 on page B-357 lists the suggested values for minimum radial internal clearance (G_r min) and the minimum circumferential clearance divided by π (c_c min/π), to be used for calculating needle roller complements for normal rotating applications – where the speeds, loads and shaft deflections are moderate.

Applications with poor lubrication, unusual motion, large misalignment, raceway distortions, load reversals, high speeds, etc., cannot be characterized as normal rotating applications. These miscellaneous applications require adjustment of the minimum clearances, listed in Table B-66 on page B-357. The factors in Table B-67 on page B-357 may be used for general guidance in the adjustment of minimal clearances. For any of the listed miscellaneous applications or any application where abnormal factors such as those listed above exist, and particularly when the inner raceway diameter will exceed 50.000 mm (1.9685 in), consult your representative for design assistance.



Table B-63. Design factors for needle rollers

Z	Number of needle rollers per bearing path
K	Chordal factor, $K = 1/\sin(180^\circ/Z)$
cc	Total circumferential clearance. See Tables B-66 and B-67 on page B-357 for cc_{min}/π values.
Gr	Radial internal clearance. See Tables B-66 and B-67 on page B-357 for Gr_{min} values
D_{pw}	Pitch diameter: $D_{pw} = KD_{w max} + (cc_{min}/\pi) = E_{min} - D_{w max}$ $= F_{max} + Gr_{min} + D_{w max}$
E	Outer raceway bore diameter: $E_{min} = D_{pw} + D_{w max} = (K + 1)D_{w max} + (cc_{min}/\pi)$ $= F_{max} + Gr_{min} + 2D_{w max}$
F	Inner raceway diameter: $F_{max} = D_{pw} - D_{w max} - Gr_{min}$ $= (K-1)D_{w max} + (cc_{min}/\pi) - Gr_{min}$ $= E_{min} - 2D_{w max} - Gr_{min}$
D_w	Nominal needle roller diameter
D_{we}	Needle roller diameter applicable in the calculation of load ratings: $D_{we} = D_{pw} - F_{max} - Gr_{min} = \frac{D_{pw} - cc_{min}/\pi}{K}$ $= \frac{F_{max} + Gr_{min} - (cc_{min}/\pi)}{(K-1)}$ $= E_{min} - D_{pw} = \frac{E_{min} - cc_{min}/\pi}{(K+1)}$
L_w	Overall needle roller length
R_w	End radius, rounded-end needle roller
r_s	Corner rounding, flat-end needle roller
L_{we}	Needle roller length applicable in the calculation of load ratings, for rounded-end needle rollers: $L_{we} = L_{w max} - \sqrt{L_{w max}^2 - D_{we}^2}$ For flat-end needle rollers: $L_{we} = L_{w max} - (2r_s)$

Note: If length of contact of the needle roller with the raceway is reduced because of undercuts, chamfers, etc. — L_{we} must be reduced correspondingly.

RACEWAY DIAMETER TOLERANCES

Tables B-68(1) and (2) on page B-357 lists the recommended tolerances that should be applied to the dimensions for the maximum inner raceway and minimum outer raceway diameter after they have been calculated using the information given in Table B-63 or Table B-64.

Table B-64. Raceway calculation form

Step	Source	Design factor	mm (in)
1	Given	D_w , needle roller diameter	3.000 max. (0.1181)
2	Table B-65	K, for 30 needle rollers	9.56677 (0.3766)
3	(1) X (2)	KD_w	28.700 (1.1299)
4	Table B-66 on page B-357	$cc_{min}/\pi = 0.025$	0.025 min. (0.0010 min.)
5	(3) + (4)	D_{pw} pitch diameter	28.725 (1.1309)
6	Given	D_w , needle roller diameter	3.000 max. (0.1181 max.)
7	(5) - (6)		25.725 (1.0128)
8	Table B-66 on page B-357	Gr , radial clearance	0.013 min. (0.0005 min.)
9	(7) - (8)	F, inner raceway diameter	25.712 max. (1.0122 min.) 25.703 min. ⁽¹⁾ (1.0119 min.)
10	(5) + (6)	E, outer raceway diameter	31.725 min. (1.2490 min.) 31.741 max. ⁽¹⁾ (1.2496 min.)

⁽¹⁾ Tolerance from Tables B-68(1) and (2) on page B-357.

Table B-65. K values

K values		K values		K values		K values		K values		K values	
Z	K	Z	K	Z	K	Z	K	Z	K	Z	K
6	2.00000	16	5.12583	26	8.29623	36	11.47371	46	14.65364	56	17.86471
7	2.30476	17	5.44219	27	8.61379	37	11.79163	47	14.97171	57	18.15285
8	2.61313	18	5.75877	28	8.93140	38	12.10957	48	15.28979	58	18.47100
9	2.92380	19	6.07553	29	9.24907	39	12.42752	49	15.60788	59	18.78916
10	3.23607	20	6.39245	30	9.56677	40	12.74549	50	15.92597	60	19.10732
11	3.54947	21	6.70951	31	9.88452	41	13.06348	51	16.24408		
12	3.86370	22	7.02667	32	10.20230	42	13.38149	52	16.56219		
13	4.17858	23	7.34394	33	10.52011	43	13.69951	53	16.88031		
14	4.49396	24	7.66130	34	10.83795	44	14.01754	54	17.19843		
15	4.80973	25	7.97873	35	11.15582	45	14.33559	55	17.51657		

CLEARANCES IN NEEDLE ROLLER COMPLEMENTS

Needle rollers, supplied in bulk, are generally used for full complement assemblies. Successful operation of a full complement of needle rollers not only requires careful selection of radial internal clearance, but more importantly, depends on proper circumferential clearance – or the total clearance between needle rollers.

Needle roller guidance, in a full complement assembly, depends largely on contact between needle rollers. Too little circumferential clearance causes overheating. Too much circumferential clearance in a heavily loaded full complement of needle rollers causes loss of needle roller guidance and results in needle roller skew and resultant end thrusting.

Control of radial clearance and circumferential clearance is influenced by the needle roller diameter tolerance, as well as the tolerances of the inner and outer raceway diameters.

END CLEARANCE

The total needle roller end clearance, or endplay, normally should be 0.20 mm (0.008 in) minimum per path of needle rollers.

Table B-66. Minimum clearances, normal rotating applications

F Nominal Inner Raceway Diameter mm in		CC_{min}/π	Gr_{min}
>	≤	mm in	mm in
-	3	0.025	0.006
-	0.1181	0.0010	0.0002
3	6	0.102	0.008
0.1181	0.2362	0.0040	0.0003
6	10	0.127	0.009
0.2362	0.3937	0.0050	0.0004
10	18	0.127	0.011
0.3937	0.7087	0.0050	0.0004
18	30	0.127	0.013
0.7087	1.1811	0.0050	0.0005
30	50	0.127	0.016
1.1811	1.9685	0.0050	0.0006
50	80	0.127	0.019
1.9685	3.1496	0.0050	0.0007
80	120	0.127	0.022
3.1496	4.7244	0.0050	0.0009

Table B-67. Minimum clearances, miscellaneous applications

Application	cc_{min}/π	Gr_{min}
universal joint	1/3 • normal	1/2 • normal
transmission pilot	normal	3 • normal
constant mesh gear	0.2 • roller dia.	normal
transmission planet	normal	normal
crank pin for two cycle engine	5 • normal	7 • normal

Table B-68(1). Recommended raceway diameter tolerances

F Nominal Inner Raceway Diameter mm in		Tolerance Limits (ISO h5) mm in	
>	≤	Max.	Min.
3	6	0	-0.005
0.1181	0.2362	0	-0.0002
6	10	0	-0.006
0.2362	0.3937	0	-0.0002
10	18	0	-0.008
0.3937	0.7087	0	-0.0003
18	30	0	-0.009
0.7087	1.1811	0	-0.0004
30	50	0	-0.011
1.1811	1.9685	0	-0.0004
50	80	0	-0.013
1.9685	3.1496	0	-0.0005
80	120	0	-0.015
3.1496	4.7244	0	-0.0006

Table B-68(2). Recommended raceway diameter tolerances

E Nominal Outer Raceway Diameter mm in		Tolerance Limits (ISO H6) mm in	
>	≤	Max.	Min.
3	6	0.008	0
0.1181	0.2362	0.0003	0
6	10	0.009	0
0.2362	0.3937	0.0004	0
10	18	0.011	0
0.3937	0.7087	0.0004	0
18	30	0.013	0
0.7087	1.1811	0.0005	0
30	50	0.016	0
1.1811	1.9685	0.0006	0
50	80	0.019	0
1.9685	3.1496	0.0007	0
80	120	0.022	0
3.1496	4.7244	0.0009	0



LOAD RATING AND LIFE CALCULATIONS FOR FULL COMPLEMENTS OF NEEDLE ROLLERS

Before selecting the quantity and size of needle rollers to be used in a needle roller complement, it is usually necessary to calculate the load rating required using the applied load, speed and desired life. For a review of bearing size selection, see the engineering section of this catalog.

Because it is not practical to tabulate the dynamic and static load ratings for the great number of needle roller complements that can be assembled by using different quantities, diameters and lengths of rollers, formulae are provided for the necessary calculations. See Tables B-61 and B-62 on page B-355 and Table B-63 on page B-356 for calculation of L_{we} .

For convenience, values of f_c and values of $Z^{3/4}$ have been combined into single factors ($f_c Z^{3/4}$). These factors, for a wide range of roller complements, are tabulated in Table B-69.

Table B-69. Values of $f_c Z^{3/4}$ for metric units

Z	$f_c Z^{3/4}$ kN - units		Z	$f_c Z^{3/4}$ kN - units	
	mm	in		mm	in
6	0.267	0.0105	34	1.288	0.0507
7	0.336	0.0132	35	1.310	0.0516
8	0.400	0.0158	36	1.331	0.0524
9	0.459	0.0181	37	1.353	0.0533
10	0.514	0.0202	38	1.374	0.0541
11	0.565	0.0222	39	1.394	0.0549
12	0.613	0.0241	40	1.415	0.0557
13	0.658	0.0259	41	1.435	0.0565
14	0.701	0.0276	42	1.454	0.0572
15	0.742	0.0292	43	1.474	0.0580
16	0.781	0.0308	44	1.493	0.0588
17	0.818	0.0322	45	1.512	0.0595
18	0.853	0.0336	46	1.531	0.0603
19	0.887	0.0349	47	1.549	0.0610
20	0.919	0.0362	48	1.568	0.0617
21	0.951	0.0374	49	1.586	0.0624
22	0.981	0.0386	50	1.604	0.0632
23	1.011	0.0398	51	1.621	0.0638
24	1.039	0.0409	52	1.639	0.0645
25	1.067	0.0420	53	1.656	0.0652
26	1.094	0.0430	54	1.673	0.0659
27	1.120	0.0441	55	1.690	0.0665
28	1.145	0.0451	56	1.707	0.0672
29	1.170	0.0461	57	1.724	0.0679
30	1.195	0.0471	58	1.740	0.0685
31	1.219	0.0480	59	1.757	0.0692
32	1.242	0.0489	60	1.773	0.0698
33	1.265	0.0498			

BASIC DYNAMIC LOAD RATINGS

The basic dynamic load rating C , for any roller bearing, can be calculated from the formula:

$$C = f_c (i L_{we} \cos \alpha)^{7/9} Z^{3/4} D_{we}^{29/27}$$

Where:

f_c = a factor which depends on the geometry of the bearing components, the accuracy to which the various components are made, and the material. Maximum values are listed in such standards as ISO 281 and USA ANSI-ABMA Standard 11.

i = number of rows of rollers in any one bearing.

α = nominal angle of contact. Since $\alpha = 0$ for a radial roller bearing, $\cos \alpha = 1$.

Other symbols are explained in Table B-63 on page B-356.

For single-path radial roller bearings, where $i = 1$ and $\cos \alpha = 1$, the basic dynamic load rating formula can be written as:

$$C = f_c Z^{3/4} L_{we}^{7/9} D_{we}^{29/27}$$

Example:

Calculate the basic dynamic load rating for a full complement of 28 flat-end rollers, 3.000 mm (0.1181 in) diameter and 17.800 mm (0.7008 in) length.

$$C = f_c Z^{3/4} L_{we}^{7/9} D_{we}^{29/27}$$

$f_c Z^{3/4}$ from Table B-69 on page B-358 = 1.145

$$D_{we}^{29/27} = 3^{29/27} = 3.254$$

$$L_{we} = 17.8 - 0.2 = 17.6 \text{ mm}$$

$$L_{we}^{7/9} = 17.6^{7/9} = 9.305$$

$$C = 1.145 \times 9.305 \times 3.254 = 34.7 \text{ kN}$$

When a couple load (overturning moment) is imposed on a single row of needle rollers, the resulting uneven distribution of load can seriously affect bearing life. In such cases, two rows of needle rollers are generally suggested.

Your representative should be consulted before a final selection of a needle roller complement is made.

BASIC STATIC LOAD RATING

The basic static load rating (C_0) for any roller bearing, including needle roller bearings, can be calculated from the following formula included in ISO 76, USA ANSI-ABMA Standard 11, and other Standards:

$$C_0 = f_0 \left(1 - \frac{D_{we} \cos \alpha}{D_{pw}} \right) i Z L_{we} D_{we} \cos \alpha$$

Where:

f_0 = 0.044 when kilo-newton and millimeter units are used.

D_{pw} = pitch diameter of the needle roller complement (mm).

i = number of rows of rollers in any one bearing.

α = nominal angle of contact. Since $\alpha = 0$ for radial roller bearing, $\cos \alpha = 1$.

The other symbols are described in Table B-63 on page B-356.



NEEDLE ROLLERS – INCH SERIES

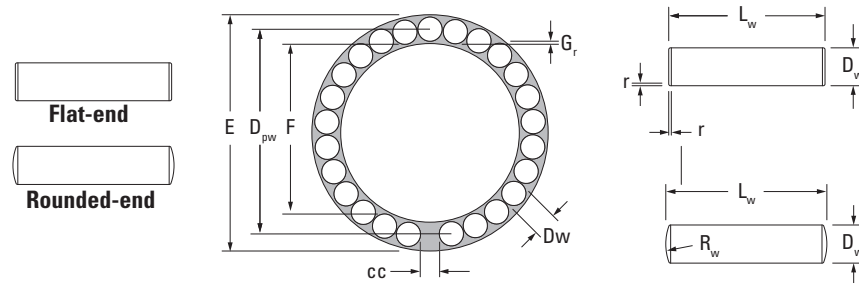

Fig. B-81. Inch series needle rollers

INTRODUCTION

Before selecting a specific needle roller complement, the engineering section should be reviewed for detailed information concerning:

- Bearing type selection.
• Bearing life and reliability.
• Definition of load ratings.
• Life and load relationships.
• Effect of raceway hardness.
• Example of life calculation.
• Lubrication.
• Shaft design.
• Housing design.

In addition to these general considerations, material which follows should also be reviewed when selecting a needle roller complement.

Standard inch series needle rollers are furnished in two styles – rounded-end or the most economical design: flat-end. Materials, dimensions and tolerances for standard needle rollers are specified in this section.

When required, needle rollers having spherical ends, conical ends, trunnion ends or crank pin ends, as well as other end designs, can be furnished. Your representative should be consulted before final needle roller selection is made.

INCH SERIES – NEEDLE ROLLER DIMENSIONS

Needle rollers are made from rolling-bearing-quality steel hardened to 60-64 HRC or equivalent. Nominally inch needle rollers are given in Table B-70. Your representative should be consulted for availability. The symbols used in Tables B-70, as well as in subsequent tables and figures, are summarized in Table B-71 on page B-362.

Needle rollers with rounded-ends permit the use of a more generous fillet between the raceway and the locating shoulder than is possible with flat-end rollers. Also, due to the length of the rounded-end, the possibility of the roller's cylindrical surface operating over the edge of the raceway is less – reducing the chance of occurrence of harmful stress concentrations. On the other hand, where design considerations permit their use, flat-end rollers achieve the maximum possible effective contact length between roller and raceway along with maximum load ratings and longer life.

Table B-70. Preferred needle roller sizes

Table with 2 columns: D_w (Nominal dia. in mm and in) and L_w (Nominal length in mm and in). Rows list various roller sizes from 3.048 mm to 63.500 mm.

* Indicates preferred needle roller sizes. Consult with your representative.

CLEARANCES IN NEEDLE ROLLER COMPLEMENTS

Needle rollers, supplied in bulk, are generally used to assemble full complement bearings. Successful operation of a full complement of rollers not only requires careful selection of radial clearance, but more importantly, depends on proper circumferential clearance – or the total clearance between rollers.

Circumferential guidance in a full complement of needle rollers depends largely on roller-to-roller contact. Too little circumferential clearance causes overheating. Too much circumferential clearance, in a heavily loaded full complement of needle rollers, causes loss of roller guidance and results in roller skew and heavy end thrust.

Control of radial clearance and circumferential clearance is influenced by the roller diameter tolerance, as well as the tolerances of the inner and outer raceway diameters.

END CLEARANCE

The total needle roller end clearance, or endplay, normally should be 0.2 mm (0.008 in) minimum per path of needle rollers.

NOMINAL-INCH NEEDLE ROLLER TOLERANCES

Unless otherwise specified, inch needle rollers are normally manufactured with a tolerance of +0.000 mm -0.005 mm (+0.0000 in -0.0002 in). This tolerance has proven acceptable and ensures satisfactory control of circumferential clearance. The needle roller length tolerance may vary with the end configuration. The normal roller length tolerance for rounded-end rollers is +0.000 mm -0.508 mm (+0.0000 in -0.0200 in).

JTEKT also manufactures needle rollers with 0.0025 mm (0.0001 in) diameter tolerance. These offer enhanced load-carrying capability and improved control of circumferential clearance. For needle rollers of greater precision, please consult with your representative.

Nominal dimensions for typical inch series needle rollers are shown in Table B-70 on page B-360. JTEKT supply rollers with smaller and larger length-to-diameter ratios for special applications. Rollers with dimensions other than those shown in Table B-70 on page B-360 can be obtained, provided the quantities permit economical production. For example, although the largest needle rollers shown in Table B-70 on page B-360 are 6.35 mm (0.2500 in) [the usual limits for needle rollers], JTEKT can produce quantities of rollers as large as 15.900 mm (0.6250 in) diameter.

Your representative should be contacted with the following information about the required needle rollers:

- Nominal metric or inch.
• Diameter and tolerance (e.g., 3.175 mm, + 0.000 mm, -0.005 mm [0.1250 in, + 0.0000 in, -0.0002 in]).
• Length and tolerance (e.g., 14.224 mm, + 0.000 mm, -0.508 mm [0.5600 in, + 0.0000 in, -0.0200 in]).
• End form (e.g., rounded-end or flat-end).

- Material (e.g., high-carbon chrome steel).
• Special features required (e.g., controlled stress).
• Quantity required.

DESIGN CALCULATIONS FOR NEEDLE ROLLER BEARING COMPLEMENTS

In the majority of full complement needle roller applications, roller complements of less than 35 needle rollers per row and a ratio of roller length to roller diameter between 4:1 and 8:1 is advantageous. Other combinations of quantity and length-to-diameter ratios of needle rollers have been used successfully. Specific design requirements usually dictate the appropriate selection.

In general, roller complements for rotating motion should employ a smaller number of larger-diameter needle rollers, while roller complements subjected to oscillating motion (especially under high loads) should employ a larger number of smaller-diameter needle rollers.

Oscillating applications with small angular travel encourage the development of fretting corrosion. The best performance under these conditions has been achieved by using the largest practical number of small-diameter needle rollers.

CALCULATION OF RACEWAY DIAMETERS

It may be convenient to use the Bearing Calculation Form in Table B-72 on page B-362 to calculate the maximum inner raceway and the minimum outer raceway diameters of a bearing. The formula given in Table B-71 on page B-362 can also be used. To assist the designer in making these calculations, the values of K, required for calculation of needle roller complements of 6 through 60 needle rollers, are listed in Table B-75 on page B-363. Values of K for other numbers of needle rollers will be furnished on request or can be calculated from the formula given in Table B-71 on page B-362.

Table B-73 on page B-362 lists the suggested values for minimum radial clearance and (G_r min) minimum circumferential clearance divided by pi (cc_min/pi), to be used for calculating needle roller complements for normal rotating applications where the speeds, loads and shaft deflections are moderate.

Applications with poor lubrication, unusual motion, large misalignment, raceway distortions, load reversals, high speeds, etc., can not be characterized as normal rotating applications. These miscellaneous applications require adjustment of the minimum clearances listed in Table B-73 on page B-362. The factors in Tables B-74 on page B-362 may be used for general guidance in the adjustment of the minimal clearances. For any of the listed miscellaneous applications or any application where abnormal factors such as those listed above exist – and particularly when the inner raceway diameter will exceed 50.800 mm (2.0000 in) – your representative should be consulted for design assistance.



Table B-71. Design factors for needle rollers

Z	Number of needle rollers per bearing path
K	Chordal factor, $K = 1/\sin(180^\circ/Z)$
cc	Total circumferential clearance. See Tables B-73 and B-74 for cc_{min}/π values.
G_r	Radial internal clearance. See Tables B-73 and B-74 for $G_{r\ min}$ values
D_{pw}	Pitch diameter: $D_{pw} = KD_{w\ max} + (cc_{min}/\pi) = E_{min} - D_{w\ max}$ $= F_{max} + G_{r\ min} + D_{w\ max}$
E	Outer raceway bore diameter: $E_{min} = D_{pw} + D_{w\ max} = (K + 1)D_{w\ max} + (cc_{min}/\pi)$ $= F_{max} + G_{r\ min} + 2D_{w\ max}$
F	Inner raceway diameter: $F_{max} = D_{pw} - D_{w\ max} - G_{r\ min}$ $= (K-1)D_{w\ max} + (cc_{min}/\pi) - G_{r\ min}$ $= E_{min} - 2D_{w\ max} - G_{r\ min}$
D_w	Nominal needle roller diameter
D_{we}	Needle roller diameter applicable in the calculation of load ratings: $D_{we} = D_{pw} - F_{max} - G_{r\ min} = \frac{D_{pw} - cc_{min}/\pi}{K}$ $= \frac{F_{max} + G_{r\ min} - (cc_{min}/\pi)}{(K-1)}$ $= E_{min} - D_{pw} = \frac{E_{min} - cc_{min}/\pi}{(K+1)}$
L_w	Overall needle roller length
R_w	End radius, rounded-end needle roller
r_s	Corner rounding, flat-end needle roller
L_{we}	Needle roller length applicable in the calculation of load ratings, for rounded-end needle rollers: $L_{we} = L_{w\ max} - (0.4D_{we})$ For flat-end needle rollers: $L_{we} = L_{w\ max} - (2r_s\ min)$

Note: If length of contact of the needle roller with the raceway is reduced because of undercuts, chamfers, etc. – L_{we} must be reduced correspondingly.

RACEWAY DIAMETER TOLERANCE LIMITS

Tables B-76(1) and (2) on page B-363 lists the recommended tolerances that should be applied to the dimensions for the maximum inner raceway and the minimum outer raceway diameter after they have been calculated using the Bearing Calculation Form, Table B-72.

Table B-72. Bearing calculation form

Step	Source	Design factor	mm (in)	
1	Given	D_w , roller diameter	3.175 (0.1250) max.	Min.
2	Table B-75	K, for 30 rollers	242.996 (9.56677)	
3	(1) x (2)	KD_w	30.373 (1.1958)	
4	Table B-73	$cc_{min}/\pi = 0.001$ in	0.025 (0.0010) min.	Max.
5	(3) + (4)	D_{pw} pitch diameter	30.399 (1.1968)	
6	Given	D_w , roller diameter	3.175 (0.1250) max.	Min.
7	(5) - (6)		27.224 (1.0718)	
8	Table B-73	G_r , radial clearance	0.013 (0.0005) min.	Max.
9	(7) - (8)	F, inner raceway diameter	27.211 (1.0713) max.	27.202 (1.0709) min. ⁽¹⁾
10	(5) + (6)	E, outer raceway diameter	33.574 (1.3218) min.	33.590 (1.3224) max. ⁽¹⁾

⁽¹⁾From Tables B-76(1) and (2) on page B-363.

Table B-73. Minimum clearances, normal rotating applications

F Nominal Inner Raceway Diameter mm in		cc_{min}/π	$G_r\ min$
>	≤	mm in	mm in
-	3	0.025	0.006
-	0.1181	0.0010	0.0002
3	6	0.102	0.008
0.1181	0.2362	0.0040	0.0003
6	10	0.127	0.009
0.2362	0.3937	0.0050	0.0004
10	18	0.127	0.011
0.3937	0.7087	0.0050	0.0004
18	30	0.127	0.013
0.7087	1.1811	0.0050	0.0005
30	50	0.127	0.016
1.1811	1.9685	0.0050	0.0006
50	80	0.127	0.019
1.9685	3.1496	0.0050	0.0007
80	120	0.127	0.022
3.1496	4.7244	0.0050	0.0009

Table B-74. Minimum clearances, miscellaneous applications

Application	cc_{min}/π	$G_r\ min$
universal joint	1/3 • normal	1/2 • normal
transmission pilot	normal	3 • normal
constant mesh gear	0.2 • roller dia.	normal
transmission planet	normal	normal
crank pin for two cycle engine	5 • normal	7 • normal

Table B-75. K values

Z	K	Z	K	Z	K	Z	K
6	2.00000	21	6.70951	36	11.47371	51	16.24408
7	2.30476	22	7.02667	37	11.79163	52	16.56219
8	2.61313	23	7.34394	38	12.10957	53	16.88031
9	2.92380	24	7.66130	39	12.42752	54	17.19843
10	3.23607	25	7.97873	40	12.74549	55	17.51657
11	3.54947	26	8.29623	41	13.06348	56	17.83471
12	3.86370	27	8.61379	42	13.38149	57	18.15285
13	4.17858	28	8.93140	43	13.69951	58	18.47100
14	4.49396	29	9.24907	44	14.01754	59	18.78916
15	4.80973	30	9.56677	45	14.33559	60	19.10732
16	5.12583	31	9.88452	46	14.65364		
17	5.44219	32	10.20230	47	14.97171		
18	5.75877	33	10.52011	48	15.28979		
19	6.07553	34	10.83795	49	15.60788		
20	6.39245	35	11.15582	50	15.92597		

Table B-76(1). Recommended raceway diameter tolerances

F Nominal Inner Raceway Diameter mm in		Tolerance Limits (ISO h5) mm in	
>	≤	Max.	Min.
3	6	0	-0.005
0.1181	0.2362	0	-0.0002
6	10	0	-0.006
0.2362	0.3937	0	-0.0002
10	18	0	-0.008
0.3937	0.7087	0	-0.0003
18	30	0	-0.009
0.7087	1.1811	0	-0.0004
30	50	0	-0.011
1.1811	1.9685	0	-0.0004
50	80	0	-0.013
1.9685	3.1496	0	-0.0005
80	120	0	-0.015
3.1496	4.7244	0	-0.0006

Table B-76(2). Recommended raceway diameter tolerances

E Nominal Outer Raceway Diameter mm in		Tolerance Limits (ISO H6) mm in	
>	≤	Max.	Min.
3	6	0.008	0
0.1181	0.2362	0.0003	0
6	10	0.009	0
0.2362	0.3937	0.0004	0
10	18	0.011	0
0.3937	0.7087	0.0004	0
18	30	0.013	0
0.7087	1.1811	0.0005	0
30	50	0.016	0
1.1811	1.9685	0.0006	0
50	80	0.019	0
1.9685	3.1496	0.0007	0
80	120	0.022	0
3.1496	4.7244	0.0009	0

KEYSTONED ROLLER ASSEMBLIES

Retention of the rollers in the outer raceway by keystoneing can be helpful in assembly operations. The following formula may be used to check the bearing design to be sure that a given number of rollers, Z, will keystone.

$$YD_{w\ min} > E_{max} = \text{keystone condition}$$

That is, the product of the keystone constant Y, given below, and the minimum roller diameter $D_{w\ min}$, must be greater than the maximum outer race bore, E_{max} .

Roller complements with 14 or more rollers usually will not keystone unless steps are taken to reduce the circumferential clearance. It is suggested that your representative be consulted when designing a keystoneed roller complement with 14 or more rollers.

Table B-77. Keystone constant

Z	Y	Z	Y
8	3.67633	14	5.51128
9	3.97094	15	5.82467
10	4.27277	16	6.13885
11	4.57895	17	6.45365
12	4.88797	18	6.76893
13	5.19892	19	7.08461



LOAD RATING AND LIFE CALCULATIONS FOR FULL COMPLEMENTS OF NEEDLE ROLLERS

Before selecting the quantity and size of needle rollers to be used in a needle roller complement, it is usually necessary to calculate the load rating required using the applied load, speed and desired life.

Since it is not practical to tabulate the dynamic and static load ratings for the great number of needle roller complements that can be assembled by using different quantities, diameters and lengths of rollers, formulae are provided for the necessary calculations.

For convenience, values of f_c and values of $Z^{3/4}$ have been combined into single factors ($f_c Z^{3/4}$). These factors for a wide range of needle roller complements are contained in Table B-78.

Table B-78. Values of $f_c Z^{3/4}$ for inch units

Z	$f_c Z^{3/4}$ lbf - units in	Z	$f_c Z^{3/4}$ lbf - units in
6	24000	36	119600
7	30200	37	121500
8	35900	38	123400
9	41200	39	125200
10	46100	40	127100
11	50700	41	128900
12	55100	42	130600
13	59100	43	132400
14	63000	44	134100
15	66600	45	135800
16	70100	46	137500
17	73400	47	139200
18	76600	48	140800
19	79700	49	142400
20	82600	50	144000
21	85400	51	145600
22	88100	52	147200
23	90800	53	148800
24	93300	54	150300
25	95800	55	151800
26	98200	56	153300
27	100600	57	154800
28	102900	58	156300
29	105100	59	157800
30	107300	60	159200
31	109500		
32	111600		
33	113600		
34	115600		
35	117600		

BASIC DYNAMIC LOAD RATINGS

The basic dynamic load rating, C, for any roller bearing can be calculated from the formula:

$$C = f_c (i L_w \cos \alpha)^{7/9} Z^{3/4} D_w^{29/27}$$

Where:

- f_c = a factor which depends on the geometry of the bearing components, the accuracy to which the various components are made, and the material. Maximum values are listed in such standards as ISO 281 and USA ANSI-ABMA Standard 11.
- i = number of rows of needle rollers in any one bearing.
- α = nominal angle of contact. Since $\alpha = 0$ for a radial needle roller bearing, $\cos \alpha = 1$.

Other symbols are explained in Table B-71 on page B-362.

For single-path radial needle roller bearings, where $i = 1$ and $\cos \alpha = 1$, the basic dynamic load rating formula can be written as:

$$C_r = f_c Z^{3/4} L_{we}^{7/9} D_w^{29/27}$$

Example:

Calculate the basic dynamic load rating in lbf for a full complement of 28 rounded-end rollers, 0.1250 inch diameter and 0.750 inch length.

$$C = f_c Z^{3/4} L_{we}^{7/9} D_w^{29/27}$$

$$f_c Z^{3/4} \text{ from Table B-78} = 102900$$

Where:

$$D_{we}^{29/27} = 0.1250^{29/27} = 0.1072$$

$$L_{we} = 0.750 - (0.4) 0.1250 = 0.700 \text{ (see Table B-71 on page B-362)}$$

$$L_{we}^{7/9} = 0.700^{7/9} = 0.758$$

$$C = 102900 \times 0.1072 \times 0.758 = 8360 \text{ lbf}$$

When a couple load (overturning moment) is imposed on a single row of needle rollers, the resulting uneven distribution of load can seriously affect bearing life. In such cases, two rows of needle rollers are generally suggested.

Your representative should be consulted before a final selection of a needle roller complement is made.

BASIC STATIC LOAD RATING

The basic static load rating (C_0) for any roller bearing, including needle roller bearings, can be calculated from the following formula included in ISO 76, USA ANSI-ABMA Standard 11 and other Standards:

$$C_0 = f_0 \left(1 - \frac{D_{we} \cos \alpha}{D_{pw}} \right) i Z L_{we} D_{we} \cos \alpha$$

Where:

- f_0 = 6430 when pound-force and inch units are used
- D_{pw} = pitch diameter of the needle roller complement (inch).
- i = number of rows of rollers in any one bearing.
- α = nominal angle of contact. Since $\alpha = 0$ for radial roller bearing, $\cos \alpha = 1$.

The other symbols are described in Table B-71 on page B-362.

CYLINDRICAL ROLLERS – METRIC SERIES

JTEKT cylindrical rollers are made from bearing-quality steel and hardened to 58-65 HRC or equivalent. Nominal metric cylindrical rollers are sorted into gages based on the mean deviation from nominal diameter and nominal length. The relieved ends of the cylindrical rollers, when used in bearing complements, help to reduce stress concentration at the ends of rollers, both under misalignment or ideal alignment. This results in a more uniform stress distribution along the roller-raceway contact length and optimum bearing performance.

METRIC SERIES CYLINDRICAL ROLLER DIMENSIONS

Nominally metric cylindrical rollers conforming to DIN 5402 sheet 1 are shown in Table B-79. Chamfer dimension limits of these cylindrical rollers with flat-ends are also shown in Table B-79. The use of these chamfer limits results in the maximum possible effective contact length between roller and raceway, along with the already mentioned relieved ends, producing the maximum possible load ratings and longer life.

Each cylindrical roller gage is packed separately, and the mean deviations of diameter and length gages are shown on the package (below the roller designation).

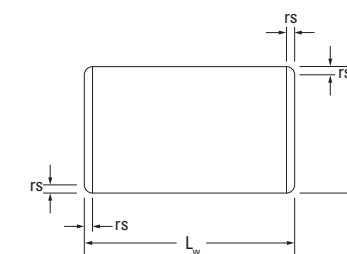

Table B-79. Dimensions of metric series cylindrical rollers

D _w	L _w	r _s min	r _s max	Cylindrical roller designation	Wt. 100 pieces approx.
Nominal diameter	Nominal length				
mm in	mm in	mm in	mm in		kg lbs
3 0.1181	5 0.1969	0.2 0.0079	0.4 0.0158	ZRO.3x5	0.027 0.060
3.5 0.1378	5 0.1969	0.2 0.0079	0.4 0.0158	ZRO.3,5x5	0.037 0.082
4 0.1575	4 0.1575	0.2 0.0079	0.4 0.0158	ZRO.4x4	0.039 0.086
4 0.1575	6 0.2362	0.2 0.0079	0.4 0.0158	ZRO.4x6	0.058 0.128
4 0.1575	8 0.3150	0.2 0.0079	0.4 0.0158	ZRO.4x8	0.078 0.172
5 0.1969	5 0.1969	0.2 0.0079	0.6 0.236	ZRO.5x5	0.075 0.165
5 0.1969	8 0.3150	0.2 0.0079	0.6 0.0236	ZRO.5x8	0.121 0.267
5.5 0.2165	8 0.3150	0.2 0.0079	0.6 0.0236	ZRO.5,5x8	0.146 0.322
6 0.2362	6 0.2362	0.2 0.0079	0.6 0.0236	ZRO.6x6	0.13 0.287
6 0.2362	12 0.4724	0.2 0.0079	0.6 0.0236	ZRO.6x12	0.261 0.575
6.5 0.2559	9 0.3543	0.2 0.0079	0.6 0.0236	ZRO.6,5x9	0.23 0.507
7 0.2756	7 0.2756	0.2 0.0079	0.6 0.0236	ZRO.7x7	0.206 0.454
7 0.2756	10 0.3937	0.2 0.0079	0.6 0.0236	ZRO.7x10	0.296 0.653
7 0.2756	14 0.5512	0.2 0.0079	0.6 0.0236	ZRO.7x14	0.417 0.919
7.5 0.2953	7.5 0.2953	0.2 0.0079	0.6 0.0236	ZRO.7,5x7,5	0.254 0.560
7.5 0.2953	9 0.3543	0.2 0.0079	0.6 0.0236	ZRO.7,5x9	0.312 0.688
7.5 0.2953	11 0.4331	0.2 0.0079	0.6 0.0236	ZRO.7,5x11	0.374 0.825
8 0.3150	8 0.3150	0.2 0.0079	0.6 0.0236	ZRO.8x8	0.308 0.679
8 0.3150	12 0.4724	0.2 0.0079	0.6 0.0236	ZRO.8x12	0.465 1.025
9 0.3543	10 0.3937	0.3 0.0118	0.7 0.0276	ZRO.9x10	0.5 1.102
9 0.3543	14 0.5512	0.3 0.0118	0.7 0.0276	ZRO.9x14	0.68 1.499
10 0.3937	10 0.3937	0.3 0.0118	0.7 0.0276	ZRO.10x10	0.6 1.323
10 0.3937	11 0.4331	0.3 0.0118	0.7 0.0276	ZRO.10x11	0.68 1.499
10 0.3937	14 0.5512	0.3 0.0118	0.7 0.0276	ZRO.10x14	0.85 1.874
11 0.4331	15 0.5906	0.3 0.0118	0.7 0.0276	ZRO.11x15	1.1 2.425
12 0.4724	14 0.5512	0.3 0.0118	0.7 0.0276	ZRO.12x14	1.23 2.712
13 0.5118	20 0.7874	0.4 0.0158	0.8 0.0315	ZRO.13x20	2.04 4.497
14 0.5512	14 0.5512	0.4 0.0158	0.8 0.0315	ZRO.14x14	1.66 3.660
14 0.5512	20 0.7874	0.4 0.0158	0.8 0.0315	ZRO.14x20	2.38 5.247

Note: Mass in accordance with DIN 5402.



EXAMPLE OF METRIC SERIES CYLINDRICAL ROLLER DESIGNATION AND PACKAGE MARKING:

ZR0.6 x 8
P0/M6

Nominal diameter: $D_w = 6.000$ mm
 Nominal length: $L_w = 8.000$ mm
 Mean deviation of the diameter ± 0.0010 mm (see Table B-80)
 Mean deviation of the length -0.006 mm (see Table B-81)
 The actual finished diameter is between 5.999 and 6.001 mm
 The actual finished length is between 7.991 and 7.997 mm

In the marking of the cylindrical roller gage, P identifies zero (0) or plus (+), M identifies minus (-). If a shipment of cylindrical rollers of the same size comprises several boxes, each box contains cylindrical rollers of the identical gage, although the gage may vary from box to box.

Table B-80. Diameter and form accuracy of metric series cylindrical rollers

Nominal Diameter D_w		Total Diameter Deviation		Variation of Gage	Mean Deviation of Gage DIN/ISO 1101														Circularity Deviation	
>	≤	Max.	Min.	μm	μm														Max.	
mm	mm	μm	μm	μm	μm	μm	μm	μm	μm	μm	μm	μm	μm	μm	μm	μm	μm	μm	μm	
—	20	+7	-9	2	+6	+5	+4	+3	+2	+1	0	-1	-2	-3	-4	-5	-6	-7	-8	0.8

Table B-81. Length gages of metric series cylindrical rollers

Nominal Length L_w		Total Length Deviation		Variation of Gage	Mean Deviation of Gage				Axial Runout DIN/ISO 1101
>	≤	Max.	Min.	μm	μm				μm
mm	mm	μm	μm	μm	μm	μm	μm	μm	μm
—	48	+9	-15	6	+6	0	-6	-12	6

INNER RINGS – METRIC SERIES

When it is impractical to meet the shaft raceway design requirements (hardness, surface finish, case depth, etc.) outlined in the engineering section of this catalog, standard inner rings may be used.

Inner rings are made of rolling bearing steel and after hardening, their bores, raceways and end surfaces are ground. Metric series inner rings may be used to provide inner raceway surfaces for metric series radial needle roller and cage assemblies, metric series needle roller bearings and metric series drawn cup needle roller bearings. The extended inner rings are suitable for use with bearings containing lip contact seals and for applications in which axial movement may be present.

CONSTRUCTION

Metric series inner rings are available with combinations of three primary design features. The inner rings may be purchased: without chamfers at the end of the raceway surface to allow for maximum possible raceway contact area, with lubrication holes to allow for increased lubrication to the bearing area, or with a profiled outer diameter for use in applications having a greater degree of misalignment. Table B-82 outlines the features offered in the different series.

Table B-82. Outline of features

Series	Lube Hole	Chamfers	Raceway Profile
JR		X	
JR.JS1	X	X	
JRZ.JS1	X		
IM		X	
IM...P		X	
IMC	X	X	
IM...R6		X	X

The lubrication holes are located nominally at the center of the inner ring width. The nominal diameters for the lubrication holes for inner rings listed in this section are shown in Table B-83.

Table B-83. Nominal diameters for the lubrication holes for inner ring

Series Designation	Inner Ring Bore Diameter		Nominal Lubrication Hole Diameter
	>	≤	mm
JR.JS1	20	40	2.0
JRZ.JS1	40	80	3.0
	80		3.5
IMC	All catalogue parts		2.2

The BIC and BICG Series inner rings have chamfers and oil holes and are designed to be used with the full complement, metric, needle roller bearings of Series RNA1000, RNA2000 and RNA3000. These inner rings are intended for RNA bearings of the same number; for example a BIC2020 would be used with a RNA2020.

DIMENSIONAL ACCURACY

The tolerances of size, form, and runout for metric series inner rings meet the requirements of ISO normal tolerance class for radial bearings (see the engineering section of this catalog). Most

metric series inner rings are produced with outer diameter raceway tolerance in accordance with h5 which, in most cases, is suitable for combining the metric series needle roller bearings to give the normal clearance class and for use with metric caged drawn cup bearings. An exception is the inner rings for metric, full complement drawn cup needle roller bearings; these inner rings are produced with outside diameter raceway tolerance in accordance with g5. Other raceway tolerances may also be found on inner rings for combining with needle roller bearings to give one of the clearance classes, or other specially requested radial internal clearance requirement.

Table B-84 lists the dimensional accuracy of the IM series inner rings.

Table B-84. Dimensional accuracy of IM series inner ring

Part Designation	OD Tolerance	Other Feature Tolerances
IM & IMC with P suffix	h5	ISO 492 Normal Tolerance Class
IM & IMC without P suffix	g5	Consult engineering
Series 49 (e.g. IM4901, IM4902)	Consult engineering	ISO 492 Normal Tolerance Class
Series IM 19000 & IM 20600	+0.000 / -0.005 mm	Consult engineering

MOUNTING OF INNER RINGS

Inner rings may be mounted on the shaft with either a loose transition fit or an interference fit. These fits, used in conjunction with the proper fit of the bearing outer ring, will provide the correct operating clearances for most applications.

Regardless of the fit of the inner ring on the shaft, the inner ring should be axially located by shaft shoulders or other positive means. The shaft shoulder diameter adjacent to the inner ring must not exceed the inner ring outer diameter (per suggestions on page B-151 of the metric series needle roller bearing section).

When metric series inner rings are to be used with the metric series needle roller bearings, appropriate shaft tolerances should be selected from Table B-19 on page B-151 in the heavy-duty needle roller bearing section. When metric series inner rings are to be used with drawn-cup bearings, the suggested shaft tolerances are given in the "inner rings" discussion on page B-46 of the metric series drawn cup needle roller bearings section of this catalog.

INCH SERIES INNER RINGS

Inch series inner rings for use with inch series drawn cup bearings are tabulated on page B-120 of this catalog. See page B-200 for inch series inner rings for use with inch series heavy-duty needle roller bearings.

END WASHERS – METRIC SERIES

When the metric series radial needle roller and cage assembly used in series NAO and RNAO needle roller bearings without flanges cannot be axially located by suitable shoulders or side faces, end washers of series SNSH may be used. These end washers, which are made of spring steel, are designed to be guided in the housing bore. They are tabulated on page B-385.



INNER RINGS
METRIC SERIES

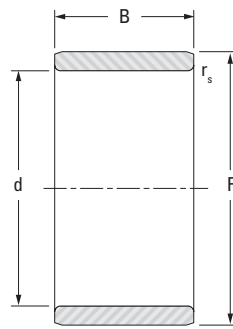

JR, IM..P

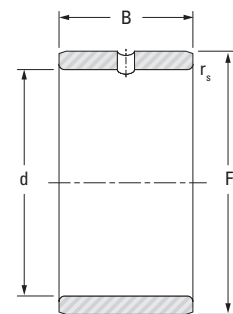

JR.JS1

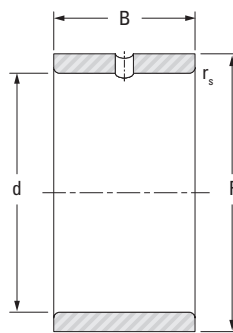

JRZ.JS1

Shaft Dia.	d	F ⁽¹⁾	B	r _s min	Inner Ring Designation	Wt.
mm in	mm in	mm in	mm in	mm in		kg lbs
5 0.1969	5 0.1969	8 0.3150	8 0.3150	0.3 0.01	JR5x8x8JS1	0.002 0.004
	5 0.1969	8 0.3150	12 0.4724	0.3 0.01	JR5x8x12	0.003 0.007
	5 0.1969	8 0.3150	16 0.630	0.3 0.01	JR5x8x16	0.004 0.009
6 0.2362	6 0.2362	9 0.3543	8 0.315	0.3 0.01	JR6x9x8JS1	0.002 0.004
	6 0.2362	9 0.3543	12 0.4724	0.3 0.01	JR6x9x12	0.003 0.007
	6 0.2362	9 0.3543	16 0.630	0.3 0.01	JR6x9x16	0.004 0.009
	6 0.2362	10 0.3937	10 0.394	0.3 0.01	JR6x10x10	0.004 0.009
	6 0.2362	10 0.3937	10 0.394	0.3 0.01	JR6x10x10JS1	0.004 0.009
	6 0.2362	10 0.3937	12 0.4724	0.3 0.01	JRZ6x10x12JS1	0.005 0.011
7 0.2756	7 0.2756	10 0.3937	10.5 0.413	0.3 0.01	JR7x10x10.5	0.003 0.007
	7 0.2756	10 0.3937	12 0.4724	0.3 0.01	JR7x10x12	0.004 0.009
	7 0.2756	10 0.3937	16 0.630	0.3 0.01	JR7x10x16	0.005 0.011
8 0.3150	8 0.3150	12 0.4724	10 0.394	0.3 0.01	JR8x12x10	0.005 0.011
	8 0.3150	12 0.4724	10 0.394	0.3 0.01	JR8x12x10JS1	0.005 0.011
	8 0.3150	12 0.4724	10.5 0.413	0.3 0.01	JR8x12x10.5	0.005 0.011
	8 0.3150	12 0.4724	12 0.472	0.3 0.01	JRZ8x12x12JS1	0.006 0.013
	8 0.3150	12 0.4724	12.5 0.492	0.3 0.01	JR8x12x12.5	0.006 0.013
	8 0.3150	12 0.4724	16 0.630	0.3 0.01	IM 8 12 16 P	0.007 0.016
9 0.3543	9 0.3543	12 0.4724	12 0.4724	0.3 0.01	JR9x12x12	0.005 0.011
	9 0.3543	12 0.4724	16 0.630	0.3 0.01	JR9x12x16	0.006 0.013
10 0.3937	10 0.3937	13 0.5118	12.5 0.492	0.3 0.01	JR10x13x12.5	0.005 0.011
	10 0.3937	14 0.5512	11 0.433	0.3 0.01	JR10x14x11JS1	0.007 0.015
	10 0.3937	14 0.5512	12 0.4724	0.3 0.01	JR10x14x12	0.007 0.015
	10 0.3937	14 0.5512	12 0.4724	0.3 0.01	JR10x14x12JS1	0.007 0.015

⁽¹⁾ Inner rings for metric full complement needle roller bearings are produced with outside diameter tolerance g5.

Continued on next page.

INNER RINGS — continued
METRIC SERIES

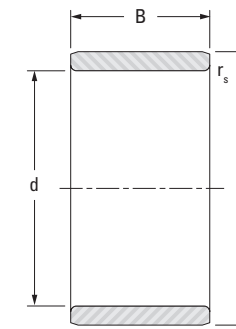

JR, IM..P

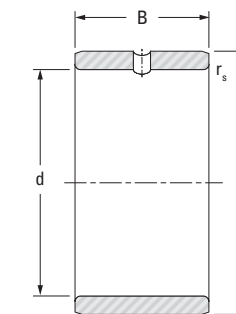

JR.JS1

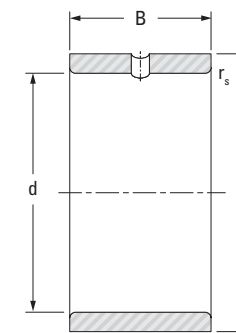

JRZ.JS1

Shaft Dia.	d	F ⁽¹⁾	B	r _s min	Inner Ring Designation	Wt.
mm in	mm in	mm in	mm in	mm in		kg lbs
10 0.3937	10 0.3937	14 0.5512	13 0.512	0.3 0.01	JR10x14x13	0.007 0.015
	10 0.3937	14 0.5512	14 0.551	0.3 0.01	JRZ10x14x14JS1	0.008 0.018
	10 0.3937	14 0.5512	16 0.630	0.3 0.01	JR10x14x16	0.009 0.020
	10 0.3937	14 0.5512	20 0.787	0.3 0.01	JR10x14x20	0.012 0.026
12 0.4724	12 0.4724	15 0.5906	12.5 0.492	0.3 0.01	JR12x15x12.5	0.006 0.013
	12 0.4724	15 0.5906	16 0.630	0.3 0.01	JR12x15x16	0.008 0.018
	12 0.4724	15 0.5906	16.5 0.650	0.3 0.01	JR12x15x16.5	0.008 0.018
	12 0.4724	15 0.5906	18.5 0.728	0.3 0.01	JR12x15x18.5	0.009 0.020
	12 0.4724	15 0.5906	22.4 0.882	0.2 0.01	IM 12 15 22.4 P	0.011 0.024
	12 0.4724	15 0.5906	22.5 0.886	0.3 0.01	JR12x15x22.5	0.011 0.024
	12 0.4724	16 0.6299	12 0.472	0.3 0.01	JR12x16x12	0.008 0.018
	12 0.4724	16 0.6299	12 0.472	0.3 0.01	JR12x16x12JS1	0.008 0.018
	12 0.4724	16 0.6299	13 0.512	0.3 0.01	JR12x16x13	0.008 0.018
	12 0.4724	16 0.6299	14 0.551	0.3 0.01	JRZ12x16x14JS1	0.010 0.022
	12 0.4724	16 0.6299	16 0.630	0.3 0.01	JR12x16x16	0.011 0.024
	12 0.4724	16 0.6299	20 0.787	0.3 0.01	JR12x16x20	0.014 0.031
	12 0.4724	16 0.6299	22 0.866	0.3 0.01	JR12x16x22	0.015 0.033
13 0.5118	13 0.5118	18 0.7087	16 0.630	0.35 0.014	IM 13 18 16 P	0.015 0.033
14 0.5512	14 0.5512	17 0.6693	17 0.669	0.3 0.01	JR14x17x17	0.009 0.020
15 0.5906	15 0.5906	18 0.7087	16.5 0.650	0.3 0.01	JR15x18x16.5	0.010 0.022
	15 0.5906	19 0.7480	16 0.630	0.3 0.01	JR15x19x16	0.013 0.029
	15 0.5906	19 0.7480	20 0.787	0.3 0.01	JR15x19x20	0.017 0.037
	15 0.5906	20 0.7874	12 0.472	0.3 0.01	JR15x20x12	0.012 0.026
	15 0.5906	20 0.7874	12 0.472	0.3 0.01	JR15x20x12JS1	0.012 0.026

⁽¹⁾ Inner rings for metric full complement needle roller bearings are produced with outside diameter tolerance g5.

Continued on next page.



INNER RINGS — continued
METRIC SERIES

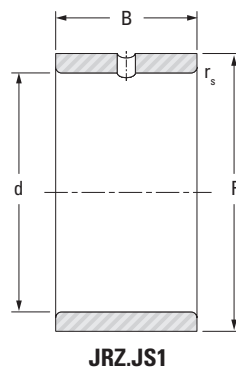
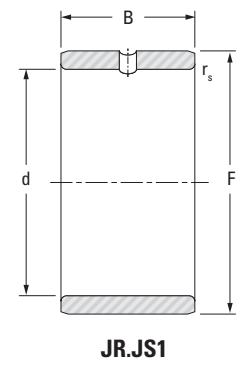
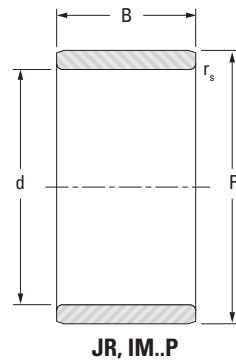

Shaft Dia.	d	F ⁽¹⁾	B	r _s min	Inner Ring Designation	Wt.
mm in	mm in	mm in	mm in	mm in		kg lbs
15 0.5906	15 0.5906	20 0.7874	13 0.512	0.3 0.01	JR15x20x13	0.014 0.031
	15 0.5906	20 0.7874	14 0.551	0.3 0.01	JRZ15x20x14JS1	0.015 0.033
	15 0.5906	20 0.7874	16 0.630	0.3 0.01	JR15x20x16	0.017 0.037
	15 0.5906	20 0.7874	20 0.787	0.35 0.014	IM 15 20 20 P	0.021 0.045
	15 0.5906	20 0.7874	23 0.906	0.3 0.01	JR15x20x23	0.025 0.055
	15 0.5906	20 0.7874	26 1.024	0.3 0.01	JR15x20x26	0.028 0.062
17 0.6693	17 0.6693	20 0.7874	16.5 0.650	0.3 0.01	JR17x20x16.5	0.011 0.024
	17 0.6693	20 0.7874	20 0.787	0.3 0.01	JR17x20x20	0.014 0.031
	17 0.6693	20 0.7874	20.5 0.807	0.3 0.01	JR17x20x20.5	0.014 0.031
	17 0.6693	20 0.7874	30.5 1.201	0.3 0.01	JR17x20x30.5	0.021 0.046
	17 0.6693	21 0.8268	16 0.630	0.3 0.01	JR17x21x16	0.015 0.033
	17 0.6693	21 0.8268	20 0.787	0.3 0.01	JR17x21x20	0.019 0.042
	17 0.6693	22 0.8661	13 0.512	0.3 0.01	JR17x22x13	0.015 0.033
	17 0.6693	22 0.8661	13 0.512	0.35 0.014	IM 4903	0.015 0.033
	17 0.6693	22 0.8661	16 0.630	0.3 0.01	JR17x22x16	0.019 0.042
	17 0.6693	22 0.8661	16 0.630	0.3 0.01	JR17x22x16JS1	0.019 0.042
	17 0.6693	22 0.8661	16 0.630	0.3 0.01	JRZ17x22x16JS1	0.019 0.042
	17 0.6693	22 0.8661	20 0.787	0.35 0.014	IM 17 22 20 P	0.023 0.051
	17 0.6693	22 0.8661	23 0.906	0.3 0.01	JR17x22x23	0.028 0.062
	17 0.6693	22 0.8661	26 1.024	0.3 0.01	JR17x22x26	0.031 0.068
	17 0.6693	22 0.8661	32 1.260	0.3 0.01	JR17x22x32	0.038 0.084
20 0.7874	20 0.7874	24 0.9449	16 0.630	0.3 0.01	JR20x24x16	0.018 0.040
	20 0.7874	24 0.9449	20 0.787	0.3 0.01	JR20x24x20	0.022 0.049
	20 0.7874	25 0.9843	16 0.630	0.3 0.01	JR20x25x16	0.022 0.049

⁽¹⁾ Call for O.D. tolerance

Continued on next page.

INNER RINGS — continued
METRIC SERIES

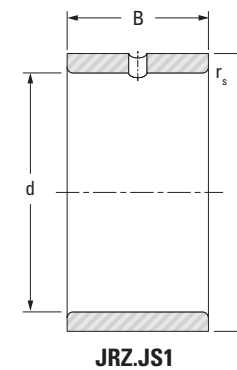
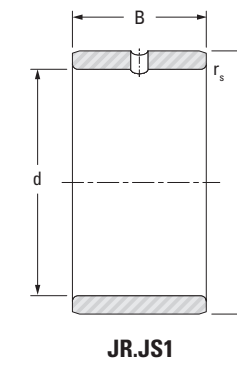
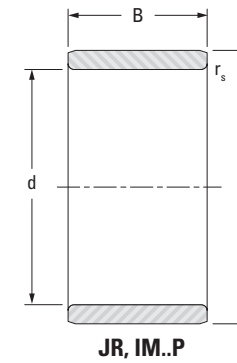

Shaft Dia.	d	F ⁽¹⁾	B	r _s min	Inner Ring Designation	Wt.
mm in	mm in	mm in	mm in	mm in		kg lbs
20 0.7874	20 0.7874	25 0.9843	16 0.630	0.3 0.01	JR20x25x16JS1	0.022 0.049
	20 0.7874	25 0.9843	17 0.669	0.3 0.01	JR20x25x17	0.023 0.051
	20 0.7874	25 0.9843	18 0.709	0.3 0.01	JRZ20x25x18JS1	0.025 0.055
	20 0.7874	25 0.9843	20 0.787	0.3 0.01	JR20x25x20	0.028 0.062
	20 0.7874	25 0.9843	20.5 0.807	0.3 0.01	JR20x25x20.5	0.029 0.064
	20 0.7874	25 0.9843	26 1.024	0.3 0.01	JR20x25x26	0.036 0.079
	20 0.7874	25 0.9843	26.5 1.043	0.3 0.01	JR20x25x26.5	0.037 0.082
	20 0.7874	25 0.9843	30 1.181	0.3 0.01	JR20x25x30	0.042 0.093
	20 0.7874	25 0.9843	32 1.260	0.3 0.01	JR20x25x32	0.044 0.097
	20 0.7874	25 0.9843	38.5 1.516	0.3 0.01	JR20x25x38.5	0.054 0.119
22 0.8661	22 0.8661	26 1.0236	16 0.630	0.3 0.01	JR22x26x16	0.019 0.042
	22 0.8661	26 1.0236	20 0.787	0.3 0.01	JR22x26x20	0.023 0.051
	22 0.8661	28 1.1024	17 0.669	0.3 0.01	JR22x28x17	0.030 0.066
	22 0.8661	28 1.1024	20.5 0.807	0.3 0.01	JR22x28x20.5	0.038 0.084
	22 0.8661	28 1.1024	30 1.181	0.3 0.01	JR22x28x30	0.056 0.123
23 0.9055	23 0.9055	28 1.1024	20 0.787	0.35 0.014	IM 23 28 20 P	0.030 0.066
25 0.9843	25 0.9843	29 1.1417	20 0.787	0.3 0.01	JR25x29x20	0.027 0.060
	25 0.9843	29 1.1417	30 1.181	0.3 0.01	JR25x29x30	0.040 0.088
	25 0.9843	30 1.1811	16 0.630	0.3 0.01	JR25x30x16	0.027 0.060
	25 0.9843	30 1.1811	16 0.630	0.3 0.01	JR25x30x16JS1	0.027 0.060
	25 0.9843	30 1.1811	17 0.669	0.3 0.01	JR25x30x17	0.028 0.062
	25 0.9843	30 1.1811	18 0.709	0.3 0.01	JRZ25x30x18JS1	0.031 0.068
	25 0.9843	30 1.1811	20 0.787	0.3 0.01	JR25x30x20	0.034 0.075
	25 0.9843	30 1.1811	20.5 0.807	0.3 0.01	JR25x30x20.5	0.035 0.077

⁽¹⁾ Call for O.D. tolerance

Continued on next page.



INNER RINGS — continued
METRIC SERIES

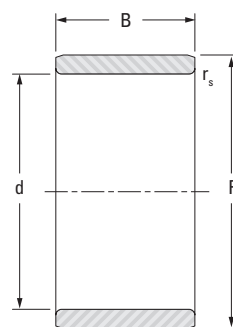

JR, IM..P

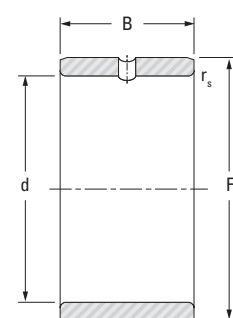

JR.JS1

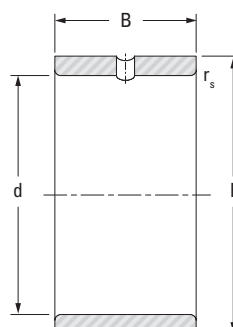

JRZ.JS1

Shaft Dia.	d	F ⁽¹⁾	B	r _s min	Inner Ring Designation	Wt.
mm in	mm in	mm in	mm in	mm in		kg lbs
25 0.9843	25 0.9843	30 1.1811	26 1.024	0.3 0.01	JR25x30x26	0.044 0.097
	25 0.9843	30 1.1811	26.5 1.043	0.3 0.01	JR25x30x26.5	0.045 0.099
	25 0.9843	30 1.1811	30 1.181	0.3 0.01	JR25x30x30	0.051 0.112
	25 0.9843	30 1.1811	32 1.260	0.3 0.01	JR25x30x32	0.054 0.119
	25 0.9843	30 1.1811	38.5 1.516	0.3 0.01	JR25x30x38.5	0.066 0.146
28 1.1024	28 1.1024	32 1.2598	17 0.669	0.3 0.01	JR28x32x17	0.028 0.062
	28 1.1024	32 1.2598	20 0.787	0.3 0.01	JR28x32x20	0.030 0.066
	28 1.1024	32 1.2598	30 1.181	0.3 0.01	JR28x32x30	0.044 0.097
30 1.1811	30 1.1811	35 1.3780	16 0.630	0.3 0.01	JR30x35x16	0.031 0.068
	30 1.1811	35 1.3780	17 0.669	0.3 0.01	JR30x35x17	0.033 0.073
	30 1.1811	35 1.3780	17 0.669	0.35 0.014	IM 4906	0.033 0.073
	30 1.1811	35 1.3780	18 0.709	0.3 0.01	JRZ30x35x18JS1	0.036 0.079
	30 1.1811	35 1.3780	20 0.787	0.3 0.01	JR30x35x20	0.039 0.086
	30 1.1811	35 1.3780	20 0.787	0.3 0.01	JRZ30x35x20JS1	0.039 0.086
	30 1.1811	35 1.3780	20.5 0.807	0.3 0.01	JR30x35x20.5	0.040 0.088
	30 1.1811	35 1.3780	26 1.024	0.3 0.01	JR30x35x26	0.054 0.119
	30 1.1811	35 1.3780	30 1.181	0.3 0.01	JR30x35x30	0.057 0.126
	30 1.1811	35 1.3780	32 1.260	0.3 0.01	JR30x35x32	0.062 0.137
	30 1.1811	38 1.4961	20 0.787	0.6 0.02	JR30x38x20JS1	0.067 0.148
32 1.2598	32 1.2598	37 1.4567	20 0.787	0.3 0.01	JR32x37x20	0.043 0.095
	32 1.2598	37 1.4567	30 1.181	0.3 0.01	JR32x37x30	0.064 0.141
	32 1.2598	40 1.5748	20 0.787	0.6 0.02	JR32x40x20	0.069 0.152
	32 1.2598	40 1.5748	36 1.417	0.6 0.02	JR32x40x36	0.128 0.282
35 1.3780	35 1.3780	40 1.5748	17 0.669	0.3 0.01	JR35x40x17	0.040 0.088

⁽¹⁾ Call for O.D. tolerance

Continued on next page.

INNER RINGS — continued
METRIC SERIES

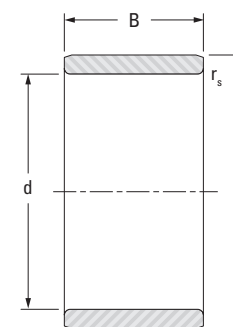

JR, IM..P

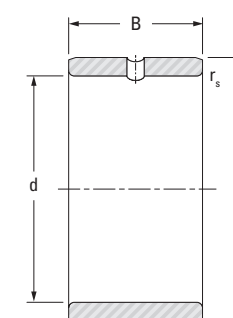

JR.JS1

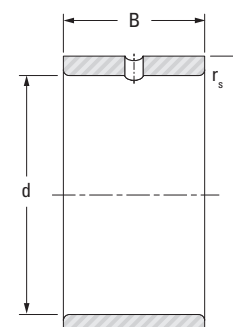

JRZ.JS1

Shaft Dia.	d	F ⁽¹⁾	B	r _s min	Inner Ring Designation	Wt.
mm in	mm in	mm in	mm in	mm in		kg lbs
35 1.3780	35 1.3780	40 1.5748	20 0.787	0.3 0.01	JR35x40x20	0.046 0.101
	35 1.3780	40 1.5748	20.5 0.807	0.3 0.01	JR35x40x20.5	0.049 0.108
	35 1.3780	40 1.5748	22 0.866	0.3 0.01	JR35x40x22	0.052 0.115
	35 1.3780	40 1.5748	30 1.181	0.3 0.01	JR35x40x30	0.071 0.157
	35 1.3780	40 1.5748	34 1.339	0.3 0.01	JR35x40x34	0.080 0.176
	35 1.3780	40 1.5748	40 1.575	0.3 0.01	JR35x40x40	0.094 0.207
	35 1.3780	42 1.6535	20 0.787	0.6 0.02	JR35x42x20	0.065 0.143
	35 1.3780	42 1.6535	20 0.787	0.6 0.02	JR35x42x20JS1	0.065 0.143
	35 1.3780	42 1.6535	23 0.906	0.6 0.02	JRZ35x42x23JS1	0.074 0.163
	35 1.3780	42 1.6535	36 1.417	0.6 0.02	JR35x42x36	0.122 0.269
	35 1.3780	44 1.7323	22 0.866	0.6 0.02	JR35x44x22	0.097 0.214
37 1.4567	37 1.4567	42 1.6535	20 0.787	0.35 0.014	IM 37 42 20 P	0.046 0.101
38 1.4961	38 1.4961	43 1.6929	20 0.787	0.3 0.01	JR38x43x20	0.050 0.110
	38 1.4961	43 1.6929	30 1.181	0.3 0.01	JR38x43x30	0.075 0.165
40 1.5748	40 1.5748	45 1.7717	17 0.669	0.3 0.01	JR40x45x17	0.044 0.097
	40 1.5748	45 1.7717	20 0.787	0.3 0.01	JR40x45x20	0.052 0.115
	40 1.5748	45 1.7717	20.5 0.807	0.3 0.01	JR40x45x20.5	0.054 0.119
	40 1.5748	45 1.7717	25 0.984	0.35 0.014	IM 40 45 25 P	0.062 0.137
	40 1.5748	45 1.7717	30 1.181	0.3 0.01	JR40x45x30	0.078 0.172
	40 1.5748	45 1.7717	34 1.339	0.3 0.01	JR40x45x34	0.089 0.196
	40 1.5748	45 1.7717	40 1.575	0.3 0.01	JR40x45x40	0.115 0.254
	40 1.5748	48 1.8898	22 0.866	0.6 0.02	JR40x48x22	0.094 0.207
	40 1.5748	48 1.8898	23 0.906	0.6 0.02	JRZ40x48x23JS1	0.100 0.220
	40 1.5748	48 1.8898	40 1.575	0.6 0.02	JR40x48x40	0.173 0.381

⁽¹⁾ Call for O.D. tolerance

Continued on next page.



INNER RINGS – continued
METRIC SERIES

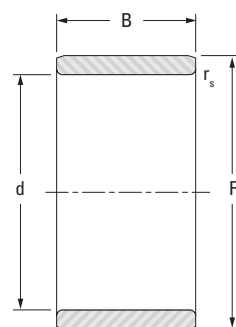

JR, IM..P

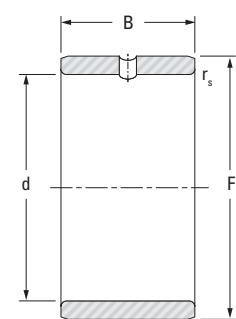

JR.JS1

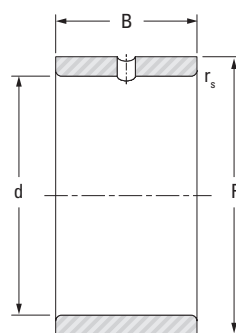

JRZ.JS1

Shaft Dia.	d	F ⁽¹⁾	B	r _s min	Inner Ring Designation	Wt.
mm in	mm in	mm in	mm in	mm in		kg lbs
40 1.5748	40 1.5748	50 1.9685	20 0.787	1 0.04	JR40x50x20	0.110 0.243
42 1.6535	42 1.6535	47 1.8504	20 0.787	0.3 0.01	JR42x47x20	0.055 0.121
	42 1.6535	47 1.8504	30 1.181	0.3 0.01	JR42x47x30	0.083 0.183
45 1.7717	45 1.7717	50 1.9685	20 0.787	0.3 0.01	JR45x50x20	0.058 0.128
	45 1.7717	50 1.9685	25 0.984	0.6 0.02	JR45x50x25	0.073 0.161
	45 1.7717	50 1.9685	25.5 1.004	0.3 0.01	JR45x50x25.5	0.075 0.165
	45 1.7717	50 1.9685	35 1.378	0.6 0.02	JR45x50x35	0.103 0.227
	45 1.7717	50 1.9685	40 1.575	0.3 0.01	JR45x50x40	0.117 0.258
	45 1.7717	52 2.0472	22 0.866	0.6 0.02	JR45x52x22	0.090 0.198
	45 1.7717	52 2.0472	22 0.866	0.85 0.033	IM 4909	0.087 0.192
	45 1.7717	52 2.0472	23 0.906	0.6 0.02	JR45x52x23	0.096 0.212
	45 1.7717	52 2.0472	23 0.906	0.6 0.02	JRZ45x52x23JS1	0.096 0.212
	45 1.7717	52 2.0472	40 1.575	0.6 0.02	JR45x52x40	0.167 0.368
	45 1.7717	55 2.1654	20 0.787	1 0.04	JR45x55x20	0.133 0.293
	45 1.7717	55 2.1654	20 0.787	1 0.04	JR45x55x20JS1	0.133 0.293
	45 1.7717	55 2.1654	22 0.866	1 0.04	JR45x55x22	0.135 0.298
	45 1.7717	55 2.1654	40 1.575	1 0.04	JR45x55x40	0.247 0.545
50 1.9685	50 1.9685	55 2.1654	20 0.787	0.3 0.01	JR50x55x20	0.065 0.143
	50 1.9685	55 2.1654	25 0.984	0.6 0.02	JR50x55x25	0.081 0.179
	50 1.9685	55 2.1654	35 1.378	0.65 0.026	IM 50 55 35 P	0.107 0.236
	50 1.9685	55 2.1654	35 1.378	0.6 0.02	JR50x55x35	0.113 0.249
	50 1.9685	55 2.1654	40 1.575	0.3 0.01	JR50x55x40	0.130 0.287
	50 1.9685	58 2.2835	22 0.866	0.6 0.02	JR50x58x22	0.117 0.258
	50 1.9685	58 2.2835	23 0.906	0.6 0.02	JRZ50x58x23JS1	0.122 0.269

⁽¹⁾ Call for O.D. tolerance

Continued on next page.

INNER RINGS – continued
METRIC SERIES

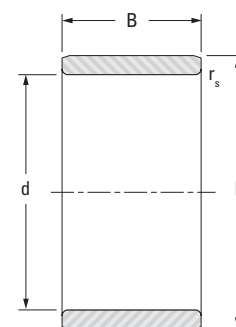

JR, IM..P

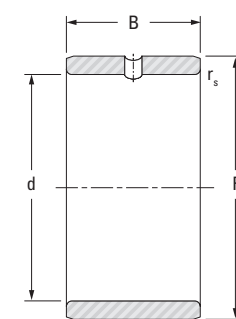

JR.JS1

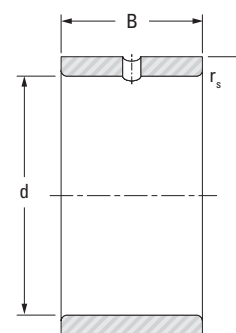

JRZ.JS1

Shaft Dia.	d	F ⁽¹⁾	B	r _s min	Inner Ring Designation	Wt.
mm in	mm in	mm in	mm in	mm in		kg lbs
50 1.9685	50 1.9685	58 2.2835	40 1.575	0.6 0.02	JR50x58x40	0.213 0.470
	50 1.9685	60 2.3622	20 0.787	1 0.04	JR50x60x20	0.155 0.342
	50 1.9685	60 2.3622	20 0.787	1 0.04	JR50x60x20JS1	0.155 0.342
	50 1.9685	60 2.3622	25 0.984	1 0.04	JR50x60x25	0.170 0.375
	50 1.9685	60 2.3622	40 1.575	1 0.04	JR50x60x40	0.310 0.683
55 2.1654	55 2.1654	60 2.3622	25 0.984	0.6 0.02	JR55x60x25	0.088 0.194
	55 2.1654	60 2.3622	35 1.378	0.65 0.026	IM 55 60 35 P	0.118 0.260
	55 2.1654	60 2.3622	35 1.378	0.6 0.02	JR55x60x35	0.124 0.273
	55 2.1654	63 2.4803	25 0.984	1 0.04	JR55x63x25	0.141 0.311
	55 2.1654	63 2.4803	45 1.772	1 0.04	JR55x63x45	0.286 0.631
	55 2.1654	65 2.5591	30 1.181	1 0.04	JR55x65x30	0.222 0.489
	55 2.1654	65 2.5591	60 2.362	1 0.04	JR55x65x60	0.444 0.979
58 2.2835	58 2.2835	65 2.5591	25 0.984	0.85 0.033	IM 58 65 25 P	0.125 0.276
60 2.3622	60 2.3622	68 2.6772	25 0.984	0.6 0.02	JR60x68x25	0.153 0.337
	60 2.3622	68 2.6772	35 1.378	0.6 0.02	JR60x68x35	0.220 0.485
	60 2.3622	68 2.6772	45 1.772	1 0.04	JR60x68x45	0.284 0.626
	60 2.3622	70 2.7559	25 0.984	1 0.04	JR60x70x25	0.200 0.441
	60 2.3622	70 2.7559	30 1.181	1 0.04	JR60x70x30	0.240 0.529
	60 2.3622	70 2.7559	35 1.378	0.85 0.033	IM 60 70 35 P	0.280 0.616
	60 2.3622	70 2.7559	60 2.362	1 0.04	JR60x70x60	0.480 1.058
65 2.5591	65 2.5591	72 2.8346	25 0.984	1 0.04	JR65x72x25	0.143 0.315
	65 2.5591	72 2.8346	45 1.772	1 0.04	JR65x72x45	0.266 0.586
65 2.5591	65 2.5591	73 2.8740	25 0.984	0.6 0.02	JR65x73x25	0.170 0.375
	65 2.5591	73 2.8740	35 1.378	0.6 0.02	JR65x73x35	0.240 0.529

⁽¹⁾ Call for O.D. tolerance

Continued on next page.



INNER RINGS – continued
METRIC SERIES

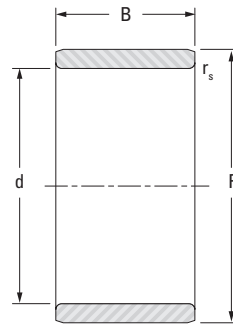

JR, IM..P

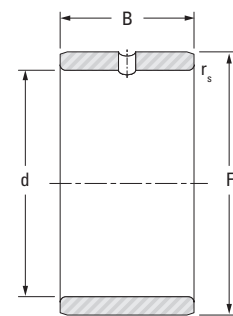

JR.JS1

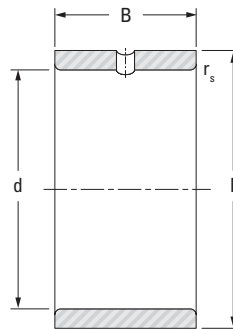

JRZ.JS1

Shaft Dia.	d	F ⁽¹⁾	B	r _s min	Inner Ring Designation	Wt.
mm in	mm in	mm in	mm in	mm in		kg lbs
65 2.5591	65 2.5591	75 2.9528	28 1.102	1 0.04	JR65x75x28	0.240 0.529
	65 2.5591	75 2.9528	30 1.181	1 0.04	JR65x75x30	0.260 0.573
	65 2.5591	75 2.9528	60 2.362	1 0.04	JR65x75x60	0.520 1.146
70 2.7559	70 2.7559	80 3.1496	25 0.984	1 0.04	JR70x80x25	0.230 0.507
	70 2.7559	80 3.1496	30 1.181	1 0.04	JR70x80x30	0.270 0.595
	70 2.7559	80 3.1496	35 1.378	1 0.04	JR70x80x35	0.320 0.705
	70 2.7559	80 3.1496	54 2.126	1 0.04	JR70x80x54	0.500 1.102
	70 2.7559	80 3.1496	60 2.362	1 0.04	JR70x80x60	0.556 1.226
75 2.9528	75 2.9528	85 3.3465	25 0.984	1 0.04	JR75x85x25	0.240 0.529
	75 2.9528	85 3.3465	30 1.181	1 0.04	JR75x85x30	0.289 0.637
	75 2.9528	85 3.3465	35 1.378	1 0.04	JR75x85x35	0.338 0.745
	75 2.9528	85 3.3465	54 2.126	1 0.04	JR75x85x54	0.530 1.168
80 3.1496	80 3.1496	90 3.5433	25 0.984	1 0.04	JR80x90x25	0.260 0.573
	80 3.1496	90 3.5433	30 1.181	1 0.04	JR80x90x30	0.306 0.675
	80 3.1496	90 3.5433	35 1.378	1 0.04	JR80x90x35	0.355 0.783
	80 3.1496	90 3.5433	54 2.126	1 0.04	JR80x90x54	0.565 1.246
85 3.3465	85 3.3465	95 3.7402	26 1.024	1 0.04	JR85x95x26	0.290 0.639
	85 3.3465	95 3.7402	30 1.181	1 0.04	JR85x95x30	0.334 0.736
	85 3.3465	95 3.7402	36 1.417	1 0.04	JR85x95x36	0.397 0.875
	85 3.3465	100 3.9370	35 1.378	1.1 0.04	JR85x100x35	0.595 1.312
	85 3.3465	100 3.9370	63 2.480	1.1 0.04	JR85x100x63	1.080 2.381
90 3.5433	90 3.5433	100 3.9370	26 1.024	1 0.04	JR90x100x26	0.300 0.661
	90 3.5433	100 3.9370	30 1.181	1 0.04	JR90x100x30	0.350 0.772
	90 3.5433	100 3.9370	36 1.417	1 0.04	JR90x100x36	0.422 0.930

⁽¹⁾ Call for O.D. tolerance

Continued on next page.

INNER RINGS – continued
METRIC SERIES

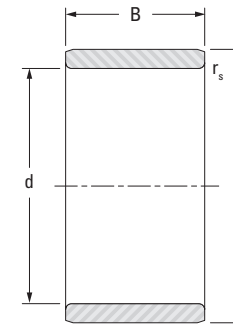

JR, IM..P

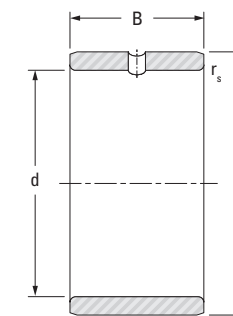

JR.JS1

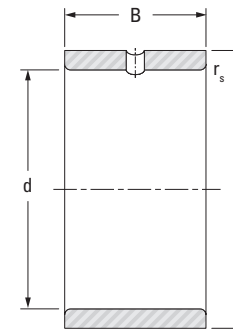

JRZ.JS1

Shaft Dia.	d	F ⁽¹⁾	B	r _s min	Inner Ring Designation	Wt.
mm in	mm in	mm in	mm in	mm in		kg lbs
90 3.5433	90 3.5433	105 4.1339	32 1.260	1.1 0.04	JR90x105x32	0.580 1.279
	90 3.5433	105 4.1339	35 1.378	1.1 0.04	JR90x105x35	0.624 1.376
	90 3.5433	105 4.1339	63 2.480	1.1 0.04	JR90x105x63	1.140 2.513
95 3.7402	95 3.7402	105 4.1339	26 1.024	1 0.04	JR95x105x26	0.310 0.683
	95 3.7402	105 4.1339	36 1.417	1 0.04	JR95x105x36	0.430 0.948
	95 3.7402	110 4.3307	35 1.378	1.1 0.04	JR95x110x35	0.653 1.440
	95 3.7402	110 4.3307	63 2.480	1.1 0.04	JR95x110x63	1.200 2.646
100 3.9370	100 3.9370	110 4.3307	30 1.181	1.1 0.04	JR100x110x30	0.384 0.847
	100 3.9370	110 4.3307	40 1.575	1.1 0.04	JR100x110x40	0.510 1.124
	100 3.9370	115 4.5276	40 1.575	1.1 0.04	JR100x115x40	0.790 1.742
110 4.3307	110 4.3307	120 4.7244	30 1.181	1 0.04	JR110x120x30	0.425 0.937
	110 4.3307	125 4.9213	40 1.575	1.1 0.04	JR110x125x40	0.870 1.918
120 4.7244	120 4.7244	130 5.1181	30 1.181	1 0.04	JR120x130x30	0.460 1.014
	120 4.7244	135 5.3150	45 1.772	1.1 0.04	JR120x135x45	1.060 2.337
130 5.1181	130 5.1181	145 5.7087	35 1.378	1.1 0.04	JR130x145x35	0.890 1.962
	130 5.1181	150 5.9055	50 1.969	1.5 0.06	JR130x150x50	1.730 3.814
140 5.5118	140 5.5118	155 6.1024	35 1.378	1.1 0.04	JR140x155x35	0.955 2.105
	140 5.5118	160 6.2992	50 1.969	1.5 0.06	JR140x160x50	1.860 4.101
150 5.9055	150 5.9055	165 6.4961	40 1.575	1.1 0.04	JR150x165x40	1.170 2.579
160 6.2992	160 6.2992	175 6.8898	40 1.575	1.1 0.04	JR160x175x40	1.240 2.734
170 6.6929	170 6.6929	185 7.2835	45 1.772	1.1 0.04	JR170x185x45	1.480 3.263
180 7.0866	180 7.0866	195 7.6772	45 1.772	1.1 0.04	JR180x195x45	1.560 3.439

⁽¹⁾ Call for O.D. tolerance



INNER RINGS FOR FULL COMPLEMENT DRAWN CUP NEEDLE ROLLER BEARINGS

METRIC SERIES

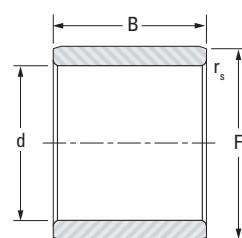

IM

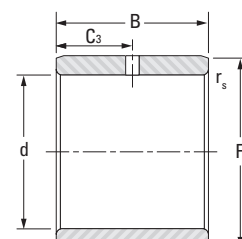

IMC

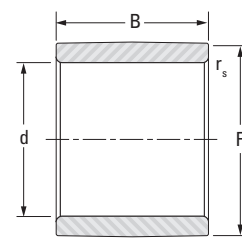

IM...R6

Table with 8 columns: Shaft Dia., d, F (1), B, Hole Location C3, r_s min, Inner Ring Designation, Wt. (kg/lbs). Rows include various IM, IMC, and IM...R6 models.

(1) Call for O.D. tolerance

Continued on next page.

INNER RINGS FOR FULL COMPLEMENT DRAWN CUP NEEDLE ROLLER BEARINGS - continued

METRIC SERIES

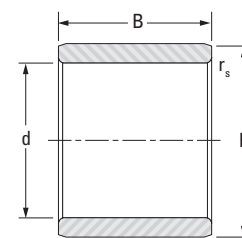

IM

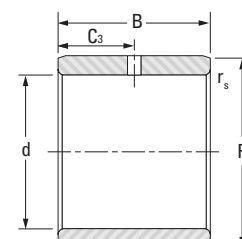

IMC

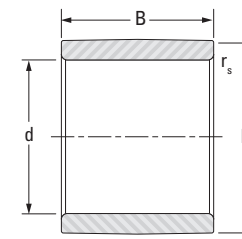

IM...R6

Table with 8 columns: Shaft Dia., d, F (1), B, Hole Location C3, r_s min, Inner Ring Designation, Wt. (kg/lbs). Rows include various IM, IMC, and IM...R6 models.

(1) Call for O.D. tolerance

Continued on next page.



INNER RINGS FOR FULL COMPLEMENT DRAWN CUP NEEDLE ROLLER BEARINGS — continued

METRIC SERIES

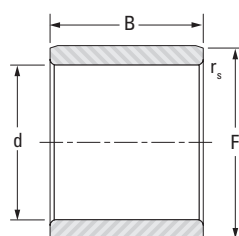

IM

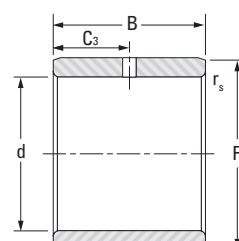

IMC

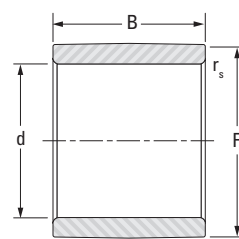

IM...R6

Shaft Dia.	d	F (1)	B	Hole Location C ₃	r _s min	Inner Ring Designation	Wt.
mm in	mm in	mm in	mm in	mm in	mm in		kg lbs
40 1.5748	40 1.5748	44 1.7323	16.4 0.646		0.3 0.01	IM 40 44 16.4 R6	0.032 0.071
	40 1.5748	44 1.7323	16.4 0.646	8.2 0.32	0.3 0.01	IMC 40 44 16.4	0.032 0.071
	40 1.5748	45 1.7717	20.4 0.803		0.35 0.014	IM 40 45 20.4	0.051 0.112
	40 1.5748	44 1.7323	20.4 0.803	10.2 0.40	0.35 0.014	IMC 40 45 20.4	0.051 0.112
45 1.7717	45 1.7717	50 1.9685	20.4 0.803		0.65 0.026	IM 45 50 20.4	0.056 0.123
	45 1.7717	50 1.9685	20.4 0.803		0.65 0.026	IM 45 50 20.4 R6	0.056 0.123
	45 1.7717	50 1.9685	25 0.984		0.65 0.026	IM 45 50 25	0.069 0.152
	45 1.7717	60 2.3622	25 0.984		0.65 0.026	IM 45 50 25 R6	0.069 0.152
50 1.9685	50 1.9685	55 2.1654	20.4 0.803		0.65 0.026	IM 50 55 20.4 R6	0.062 0.137
	50 1.9685	55 2.1654	20.4 0.803		0.65 0.026	IM 50 55 20.4	0.062 0.137

(1) Call for O.D. tolerance

INNER RINGS FOR MACHINE-TOOL QUALITY PRECISION-COMBINED BEARINGS

METRIC SERIES

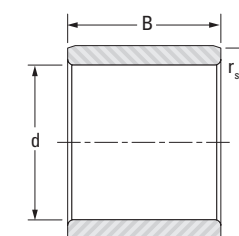

IM

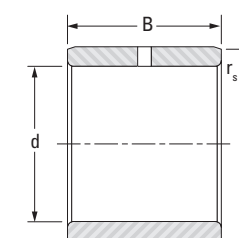

IMC

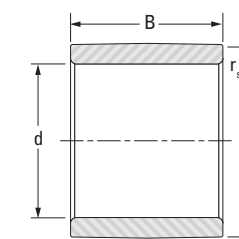

IM...R6

Shaft Dia.	d	F (1)	B	r _s min	Inner Ring Designation	Wt.
mm in	mm in	mm in	mm in	mm in		kg lbs
17 0.6693	17 0.6693	20 0.7874	27.5 1.083	0.2 0.01	IM 19017	0.019 0.042
	17 0.6693	20 0.7874	32 1.240	0.2 0.01	IM 20617	0.021 0.046
	17 0.6693	22 0.8665	13 0.512	0.35 0.014	IM 4903	0.015 0.033
20 0.7874	20 0.7874	25 0.9843	27.5 1.083	0.35 0.014	IM 19020	0.038 0.084
	20 0.7874	25 0.9843	32 1.240	0.35 0.014	IM 20620	0.044 0.097
25 0.9843	25 0.9843	30 1.1811	27.5 1.083	0.35 0.014	IM 19025	0.042 0.093
	25 0.9843	30 1.1811	32 1.240	0.35 0.014	IM 20625	0.052 0.115
30 1.1811	30 1.1811	35 1.3780	17 0.669	0.35 0.014	IM 4906	0.033 0.072
	30 1.1811	35 1.3780	27.5 1.083	0.35 0.014	IM 19030	0.053 0.117
	30 1.1811	35 1.3780	32 1.240	0.35 0.014	IM 20630	0.061 0.134
35 1.3780	35 1.3780	40 1.5748	27.5 1.083	0.35 0.014	IM 19035	0.063 0.139
	35 1.3780	40 1.5748	32 1.240	0.35 0.014	IM 20635	0.072 0.159
40 1.5748	40 1.5748	45 1.7717	27.5 1.083	0.35 0.014	IM 19040	0.069 0.152
	40 1.5748	45 1.7717	32 1.240	0.35 0.014	IM 20640	0.080 0.176
45 1.7717	45 1.7717	50 1.9685	30.5 1.201	0.65 0.026	IM 19045	0.085 0.187
	45 1.7717	50 1.9685	35 1.358	0.65 0.026	IM 20645	0.096 0.212
	45 1.7717	52 2.0476	22 0.866	0.85 0.033	IM 4909	0.087 0.192

(1) Call for O.D. tolerance



INNER RINGS WITH OIL HOLES/EXTRA WIDE, RNA BEARINGS

METRIC SERIES

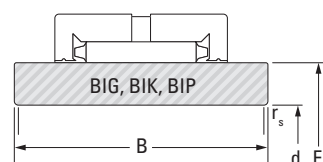
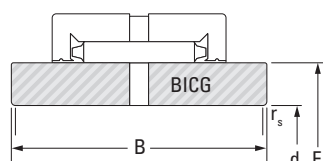
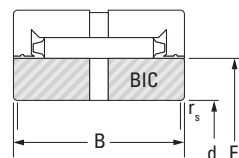

Shaft Dia.	d	F ⁽¹⁾	B	r _s min	Inner Ring Designation	Wt.
mm in	mm in	mm in	mm in	mm in		kg lbs
12 0.4724	12 0.4724	17.6 0.6929	15 0.591	1 0.04	BIC 1012	0.016 0.035
	12 0.4724	17.6 0.6929	20 0.787	1 0.04	BIP 1012	0.020 0.044
15 0.5906	15 0.5906	20.8 0.8189	15 0.591	1 0.04	BIC 1015	0.018 0.040
	15 0.5906	22.1 0.8701	22 0.866	1 0.04	BIC 2015	0.035 0.077
17 0.6693	17 0.6693	23.9 0.9409	15 0.591	1 0.04	BIC 1017	0.026 0.057
	20 0.7874	28.7 1.1299	18 0.709	1 0.04	BIC 1020	0.046 0.101
	20 0.7874	28.7 1.1299	22 0.866	1 0.04	BIC 2020	0.056 0.123
	20 0.7874	28.7 1.1299	22 0.866	1 0.04	BIP 1020	0.056 0.123
25 0.9843	25 0.9843	33.5 1.3189	18 0.709	1 0.04	BIC 1025	0.054 0.119
	25 0.9843	33.5 1.3189	22 0.866	1 0.04	BIC 2025	0.065 0.143
	25 0.9843	33.5 1.3189	30 1.181	1 0.04	BIC 22025	0.500 1.102
	25 0.9843	33.5 1.3189	32 1.260	1 0.04	BIG 2025	0.095 0.209
	25 0.9843	33.5 1.3189	42 1.654	1 0.04	BIK 2025	0.125 0.276
30 1.1811	30 1.1811	38.2 1.5039	18 0.709	1 0.04	BIC 1030	0.060 0.132
	30 1.1811	38.2 1.5039	22 0.866	1 0.04	BIC 2030	0.074 0.163
	30 1.1811	44.0 1.7323	30 1.181	1 0.04	BIC 3030	0.188 0.414
	30 1.1811	38.2 1.5039	32 1.260	1 0.04	BIG 2030	0.108 0.238
	30 1.1811	44.0 1.7323	40 1.575	1 0.04	BIG 3030	0.247 0.545
35 1.3780	35 1.3780	44.0 1.7323	18 0.709	1 0.04	BIC 1035	0.077 0.170
	35 1.3780	44.0 1.7323	22 0.866	1 0.04	BIC 2035	0.093 0.205
	35 1.3780	44.0 1.7323	32 1.260	1 0.04	BIG 2035	0.135 0.298
40 1.5748	40 1.5748	49.7 1.9567	18 0.709	1.5 0.06	BIC 1040	0.094 0.207
	40 1.5748	49.7 1.9567	22 0.866	1.5 0.06	BIC 2040	0.115 0.254
	40 1.5748	55.4 2.1811	36 1.417	1.5 0.06	BIC 3040	0.321 0.708

⁽¹⁾ Call for O.D. tolerance

Continued on next page.

INNER RINGS WITH OIL HOLES/EXTRA WIDE, RNA BEARINGS – continued

METRIC SERIES

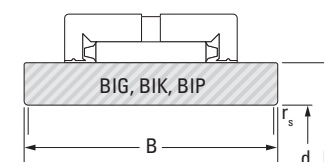
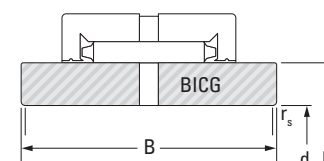
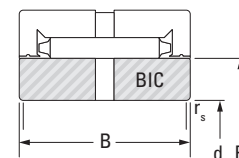

Shaft Dia.	d	F ⁽¹⁾	B	r _s min	Inner Ring Designation	Wt.
mm in	mm in	mm in	mm in	mm in		kg lbs
	40 1.5748	49.7 1.9567	32 1.260	1.5 0.06	BIG 2040	0.170 0.375
	40 1.5748	49.7 1.9567	22 0.866	1.5 0.06	BIP 1040	0.115 0.254
45 1.7717	45 1.7717	55.4 2.1811	18 0.709	1.5 0.06	BIC 1045	0.113 0.249
	45 1.7717	55.4 2.1811	22 0.866	1.5 0.06	BIC 2045	0.139 0.306
	45 1.7717	62.1 2.4449	38 1.496	1.5 0.06	BIC 3045	0.422 0.930
	45 1.7717	55.4 2.1811	32 1.260	1.5 0.06	BIG 2045	0.210 0.463
50 1.9685	50 1.9685	62.1 2.4449	20 0.787	2 0.08	BIC 1050	0.163 0.359
	50 1.9685	62.1 2.4449	24 0.945	2 0.08	BIC 11050	0.196 0.432
	50 1.9685	62.1 2.4449	28 1.102	2 0.08	BIC 2050	0.228 0.503
	50 1.9685	68.8 2.7087	38 1.496	2 0.08	BIC 3050	0.515 1.135
	50 1.9685	62.1 2.4449	38 1.496	2 0.08	BIG 2050	0.312 0.688
	50 1.9685	62.1 2.4449	28 1.102	2 0.08	BIP 1050	0.228 0.503
55 2.1654	55 2.1654	68.8 2.7087	20 0.787	2 0.08	BIC 1055	0.205 0.452
	55 2.1654	72.6 2.8583	38 1.496	2 0.08	BIC 3055	0.525 1.157
	55 2.1654	72.6 2.8583	48 1.890	2 0.08	BICG 3055	0.660 1.455
	55 2.1654	68.8 2.7087	38 1.496	2 0.08	BIG 2055	0.390 0.860
	55 2.1654	68.8 2.7087	28 1.102	2 0.08	BIP 1055	0.288 0.635
60 2.3622	60 2.3622	72.6 2.8583	28 1.102	2 0.08	BIC 2060	0.282 0.622
	60 2.3622	78.3 3.0827	38 1.496	2 0.08	BIC 3060	0.583 1.285
	60 2.3622	72.6 2.8583	38 1.496	2 0.08	BICG 2060	0.385 0.849
	60 2.3622	72.6 2.8583	38 1.496	2 0.08	BIG 2060	0.385 0.849
65 2.5591	65 2.5591	83.1 3.2717	38 1.496	2 0.08	BIC 3065	0.623 1.373
	65 2.5591	78.3 3.0827	38 1.496	2 0.08	BIG 2065	0.437 0.963
70 2.7559	70 2.7559	88.0 3.4646	38 1.496	2 0.08	BIC 3070	0.662 1.459

⁽¹⁾ Call for O.D. tolerance

Continued on next page.



INNER RINGS WITH OIL HOLES/EXTRA WIDE, RNA BEARINGS — continued

METRIC SERIES

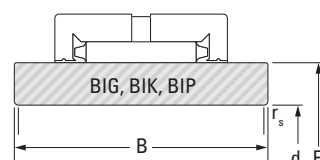
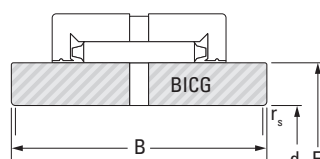
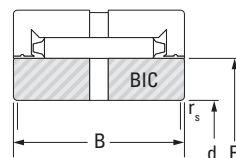

Shaft Dia.	d	F ⁽¹⁾	B	r _s min	Inner Ring Designation	Wt.
mm in	mm in	mm in	mm in	mm in		kg lbs
70 2.7559	70 2.7559	88.0 3.4646	48 1.890	2 0.08	BIG 3070	0.820 1.808
	70 2.7559	88.0 3.4646	58 2.283	2 0.08	BIK 3070	1.010 2.227
75 2.9528	75 2.9528	88.0 3.4646	32 1.260	2 0.08	BIC 2075	0.410 0.904
	75 2.9528	88.0 3.4646	42 1.654	2 0.08	BIG 2075	0.538 1.186
	75 2.9528	96.0 3.7795	58 2.283	2 0.08	BIK 3075	1.260 2.778
80 3.1496	80 3.1496	96.0 3.7795	24 0.945	2 0.08	BIC 1080	0.410 0.904
	80 3.1496	96.0 3.7795	32 1.260	2 0.08	BIC 2080	0.545 1.202
	80 3.1496	99.5 3.9173	38 1.496	2 0.08	BIC 3080	0.805 1.775
	80 3.1496	96.0 3.7795	42 1.654	2 0.08	BIG 2080	0.714 1.574
90 3.5433	90 3.5433	104.7 4.1220	32 1.260	2 0.08	BIC 2090	0.531 1.171
	90 3.5433	109.1 4.2953	43 1.693	2 0.08	BIC 3090	0.990 2.183
	90 3.5433	109.1 4.2953	53 2.087	2 0.08	BIG 3090	1.220 2.690
	90 3.5433	109.1 4.2953	63 2.480	2 0.08	BIK 3090	1.480 3.263
95 3.7402	95 3.7402	109.1 4.2953	32 1.260	2 0.08	BIC 2095	0.548 1.208
	95 3.7402	114.7 4.5157	43 1.693	2 0.08	BIC 3095	1.075 2.370
	95 3.7402	114.7 4.5157	63 2.480	2 0.08	BIK 3095	1.585 3.494
100 3.9370	100 3.9370	119.2 4.6929	43 1.693	2 0.08	BIC 3100	1.090 2.403
	100 3.9370	114.7 4.5157	42 1.654	2 0.08	BIG 2100	0.800 1.764
105 4.1339	105 4.1339	119.2 4.6929	32 1.260	2 0.08	BIC 2105	0.615 1.356
	105 4.1339	124.7 4.9094	55 2.165	2 0.08	BIG 3105	1.505 3.318
110 4.3307	110 4.3307	124.7 4.9094	34 1.339	2 0.08	BIC 2110	0.705 1.554
	110 4.3307	124.7 4.9094	44 1.732	2 0.08	BIG 2110	0.920 2.028
125 4.9213	125 4.9213	142.5 5.6102	44 1.732	2 0.08	BICG 2125	1.340 2.954
	125 4.9213	142.5 5.6102	44 1.732	2 0.08	BIG 2125	1.325 2.921
130 5.1181	130 5.1181	158.0 6.2205	52 2.047	2 0.08	BIC 3130	2.530 5.578

⁽¹⁾ Call for O.D. tolerance

END WASHERS

METRIC SERIES

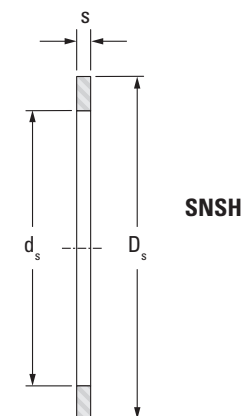

d _s	D _s	S	End Washer Designation	Wt.
mm in	mm in	mm in		kg lbs
8.0 0.315	18 0.709	2.0 0.079	SNSH8X18X2	0.003 0.007
8.5 0.335	15 0.591	0.5 0.020	SNSH8.5X15X0.5	0.0005 0.001
10.5 0.413	17 0.669	0.5 0.020	SNSH10.5X17X0.5	0.0006 0.001
10.5 0.413	20 0.787	0.5 0.020	SNSH10.5X20X0.5	0.0009 0.002
12.5 0.492	19 0.748	0.5 0.020	SNSH12.5X19X0.5	0.0006 0.001
12.5 0.492	22 0.866	0.5 0.020	SNSH12.5X22X0.5	0.0010 0.002
14.5 0.571	22 0.866	0.5 0.020	SNSH14.5X22X0.5	0.0008 0.002
14.5 0.571	26 1.024	0.5 0.020	SNSH14.5X26X0.5	0.0014 0.003
15.5 0.610	23 0.906	0.5 0.020	SNSH15.5X23X0.5	0.0009 0.002
16.5 0.650	24 0.945	0.5 0.020	SNSH16.5X24X0.5	0.0009 0.002
16.5 0.650	28 1.102	0.5 0.020	SNSH16.5X28X0.5	0.0016 0.004
17.5 0.689	25 0.984	0.5 0.020	SNSH17.5X25X0.5	0.001 0.002
18.5 0.728	26 1.024	0.5 0.020	SNSH18.5X26X0.5	0.001 0.002
18.5 0.728	30 1.181	0.5 0.020	SNSH18.5X30X0.5	0.002 0.004
20.5 0.807	28 1.102	0.5 0.020	SNSH20.5X28X0.5	0.001 0.002
20.5 0.807	32 1.260	0.5 0.020	SNSH20.5X32X0.5	0.002 0.004

d _s	D _s	S	End Washer Designation	Wt.
mm in	mm in	mm in		kg lbs
22.5 0.886	30 1.181	0.5 0.020	SNSH22.5X30X0.5	0.001 0.003
22.5 0.886	35 1.378	0.5 0.020	SNSH22.5X35X0.5	0.002 0.005
25.5 1.004	35 1.378	0.5 0.020	SNSH25.5X35X0.5	0.002 0.004
25.5 1.004	37 1.457	0.5 0.020	SNSH25.5X37X0.5	0.002 0.005
28.5 1.122	40 1.575	0.5 0.020	SNSH28.5X40X0.5	0.002 0.005
30.5 1.201	40 1.575	0.5 0.020	SNSH30.5X40X0.5	0.002 0.005
35.5 1.398	47 1.850	0.5 0.020	SNSH35.5X47X0.5	0.003 0.006
40.5 1.594	50 1.969	0.5 0.020	SNSH40.5X50X0.5	0.003 0.006
41.0 1.614	55 2.165	1.0 0.039	SNSH41X55X1	0.008 0.018
45.5 1.791	55 2.165	0.5 0.020	SNSH45.5X55X0.5	0.003 0.007
46.0 1.811	62 2.441	1.0 0.039	SNSH46X62X1	0.011 0.024
51.0 2.008	65 2.559	1.0 0.039	SNSH51X65X1	0.010 0.022
56.0 2.205	72 2.835	1.0 0.039	SNSH56X72X1	0.013 0.029
61.0 2.402	78 3.071	1.0 0.039	SNSH61X78X1	0.015 0.033
66.0 2.598	85 3.346	1.0 0.039	SNSH66X85X1	0.018 0.040



NEEDLE ROLLER BEARINGS



NOTES



C

APPLICATIONS

C NEEDLE ROLLER BEARING APPLICATIONS

C

APPLICATIONS

C

Needle Roller Bearing Applications

	<i>Page</i>
Automatic Transmissions	C-4
Manual Transmissions	C-6
Valvetrain Components	C-8
Steering Columns	C-9
Automotive Accessories	C-10
Drivetrain Components	C-12
Power Transmissions	C-13
Sport Vehicles	C-14
Marine Applications	C-16
Power Tools	C-18
Consumer Products	C-19
Mechanical Pumps	C-20
Industrial Machinery	C-21



AUTOMATIC TRANSMISSIONS

As power density and performance demands continue to increase in automatic transmissions, JTEKT has developed a large array of innovative bearing designs. These offerings help reduce mass, increase power ratings, minimize assembly time, and reduce costs. Analytical evaluations, in-house testing, and new material developments allow JTEKT to solve the most demanding automotive design problems.

FRICION REDUCTION/FUEL ECONOMY

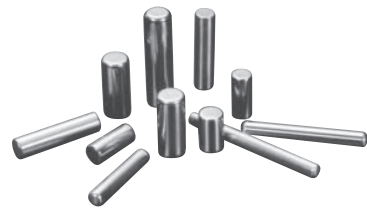

Needle rollers for planet gears

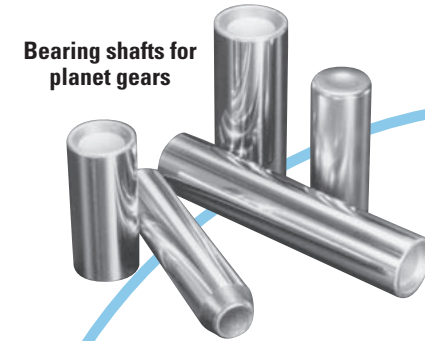

Bearing shafts for planet gears

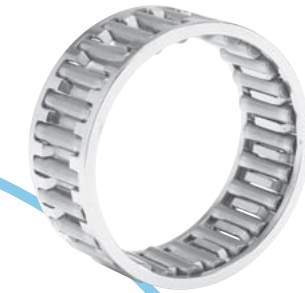

Radial needle roller and cage assembly



Planet thrust washers



Caged drawn cup bearings

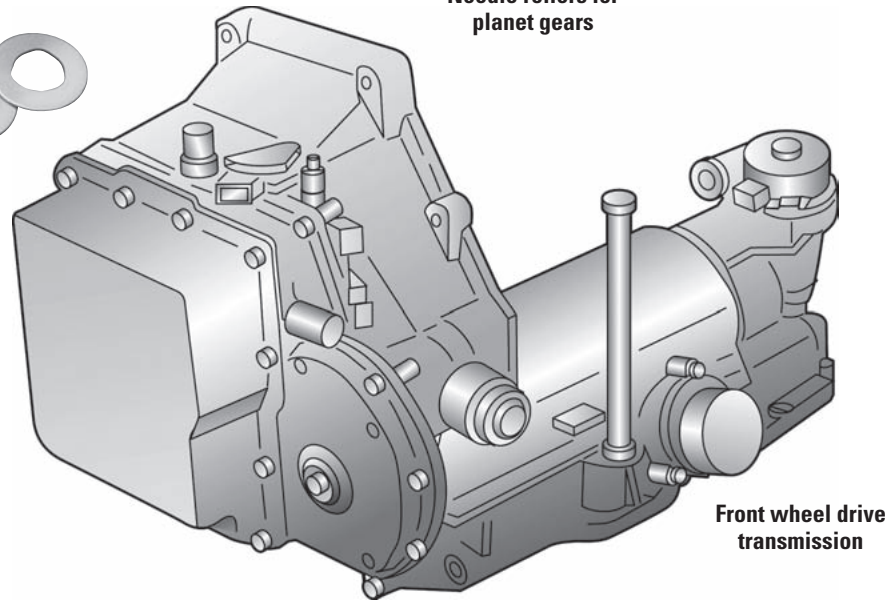

Front wheel drive transmission

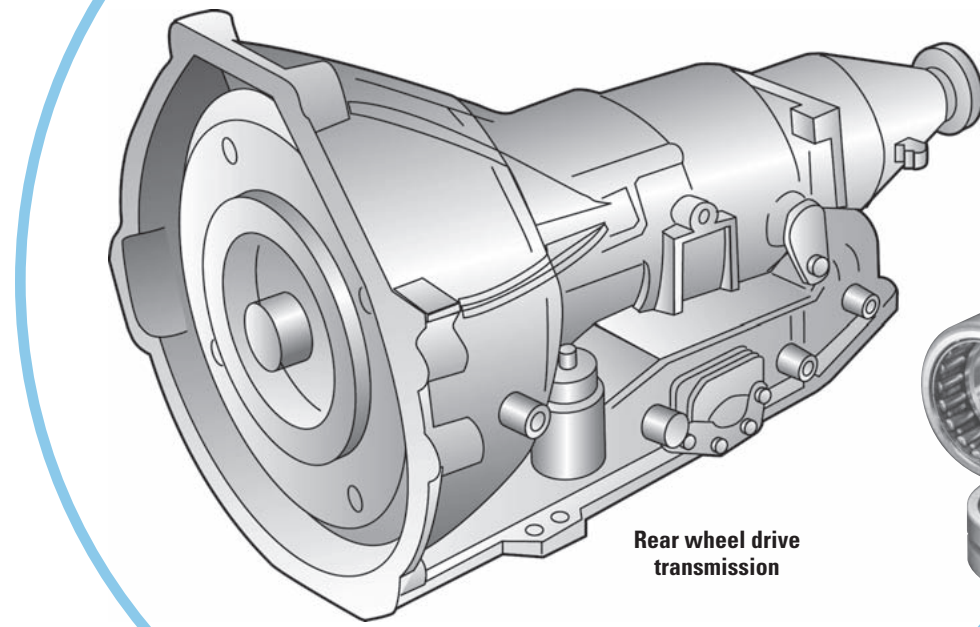

Rear wheel drive transmission



Split polymer caged radial assemblies

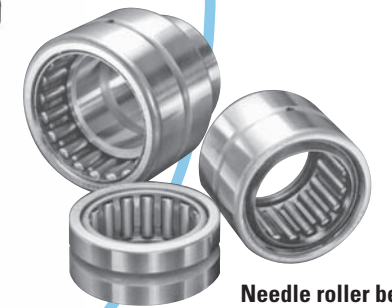

Needle roller bearings for heavy-duty applications



Drawn raceway sleeves

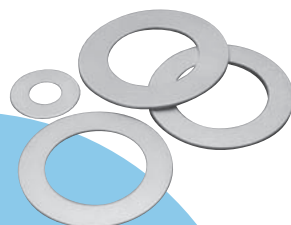

Bearing thrust washers

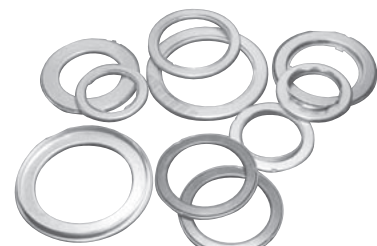

Unitized thrust bearing assemblies



Inverted drawn cup bearings

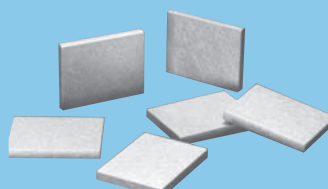

Pump vanes for transmission pumps



Park rods

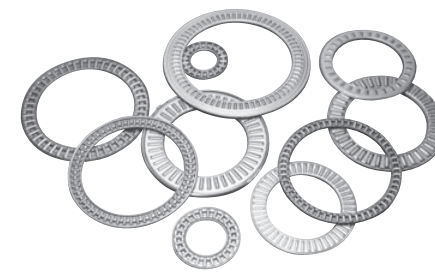

Thrust needle roller and cage assemblies



Ground inner rings



Full complement drawn cup bearings

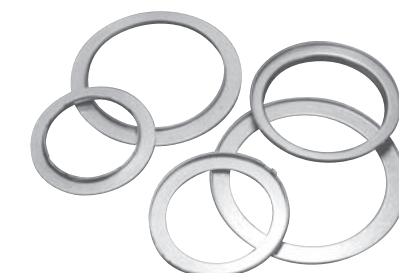

Lipped bearing thrust washers

MANUAL TRANSMISSIONS

JTEKT offers a wide range of highly reliable bearings tailored specifically for manual transmissions. These bearings allow designers to minimize cross sections while attaining peak load-carrying capability in a very cost-effective package. JTEKT has considerable experience with providing in-depth engineering analysis and creative design solutions for the most demanding transmission applications.

FUEL ECONOMY

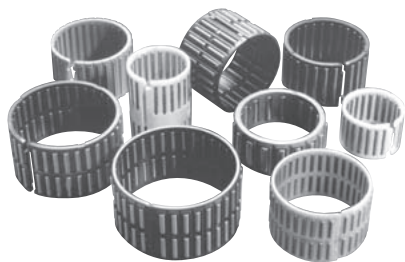

Radial needle roller and cage assemblies (Split polymer type)



Caged drawn cup bearings

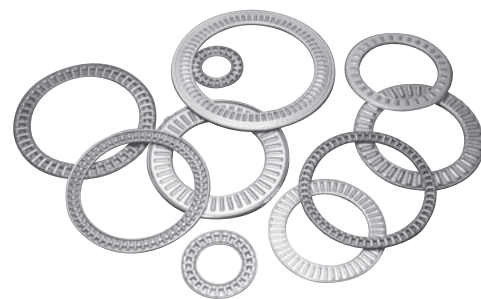

Thrust needle roller and cage assemblies

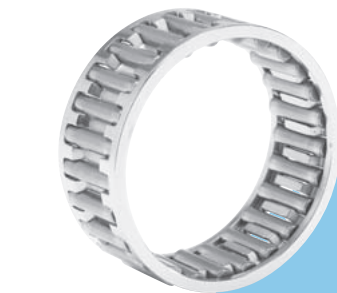

Radial needle roller and cage assembly

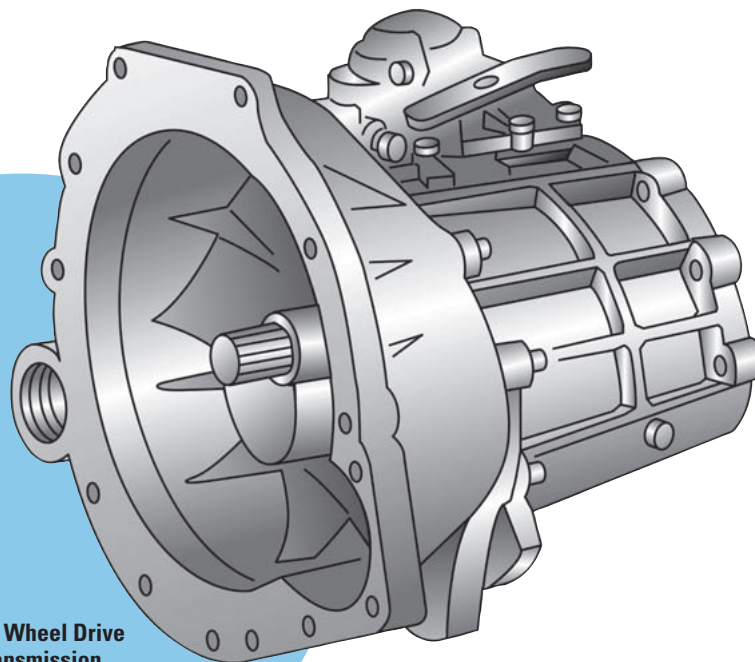

Front Wheel Drive Transmission

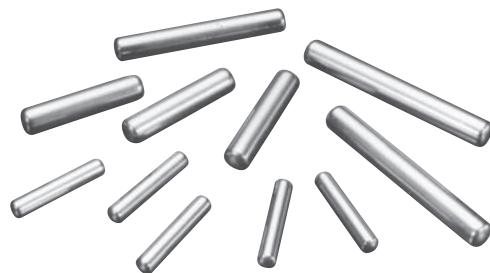

Needle rollers



Unitized thrust bearing assemblies

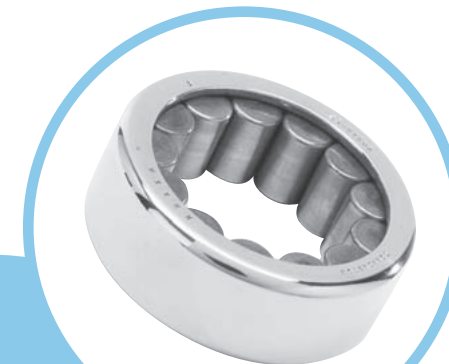

Heavy wall drawn cup bearing

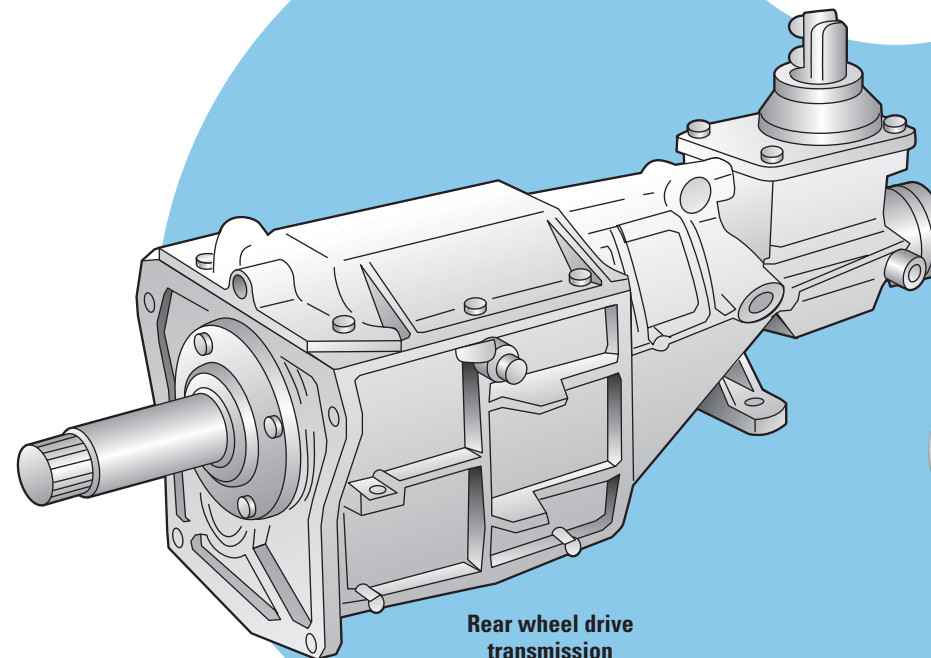

Rear wheel drive transmission

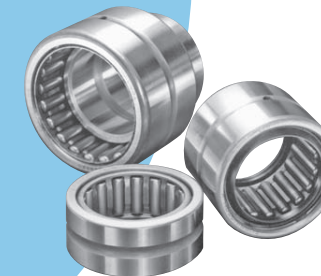

Needle roller bearings for heavy-duty applications



Drawn raceway sleeves



Full complement drawn cup bearings



Full complement drawn cup bearings

VALVETRAIN COMPONENTS

JTEKT's technical and analytical leadership in valvetrain components results in superior products that optimize mass, stiffness, moment of inertia and noise. These design features contribute to the demands of increased engine operating speeds, improved fuel economy and better overall performance.

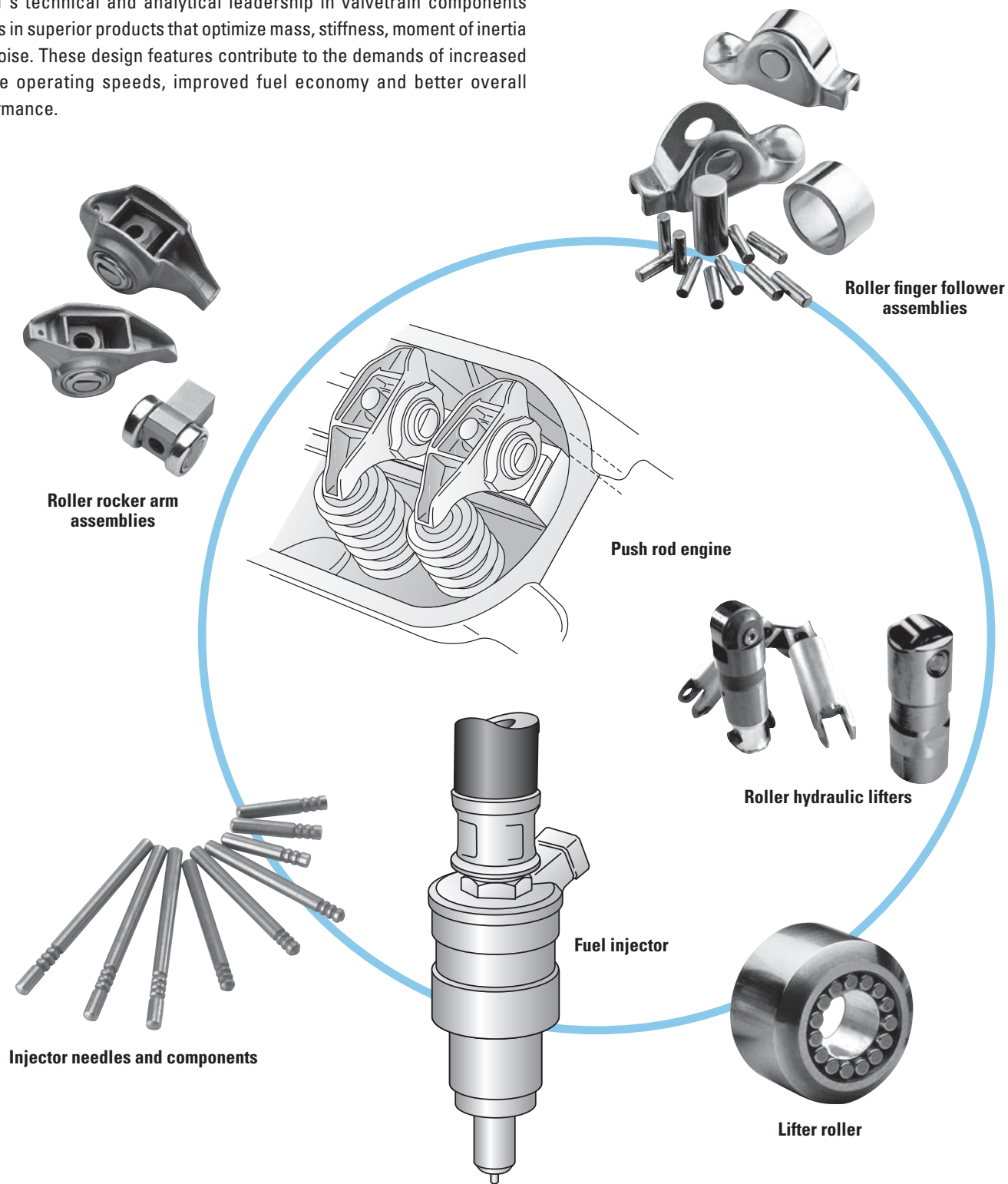

STEERING COLUMNS

JTEKT offers bearings and components dedicated strictly to steering column systems. JTEKT has the technical skills to produce innovative designs for the most demanding applications.

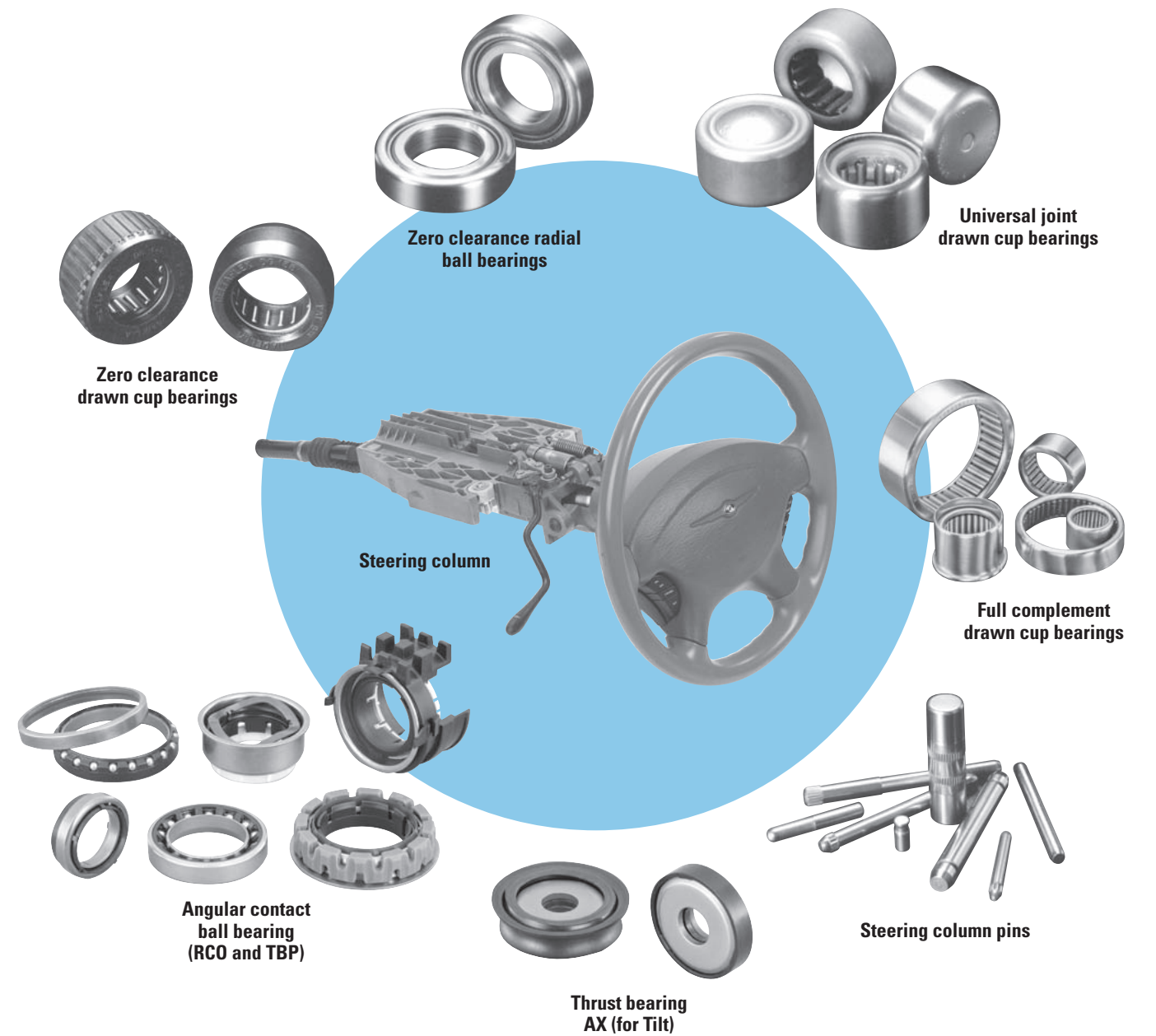

AUTOMOTIVE ACCESSORIES

Tough, compact, lightweight and innovative describe JTEKT's product offering for the automotive accessories market. Advanced analytical optimization techniques, testing and manufacturing technologies allow JTEKT to provide complete packages that result in high reliability while lowering system costs.

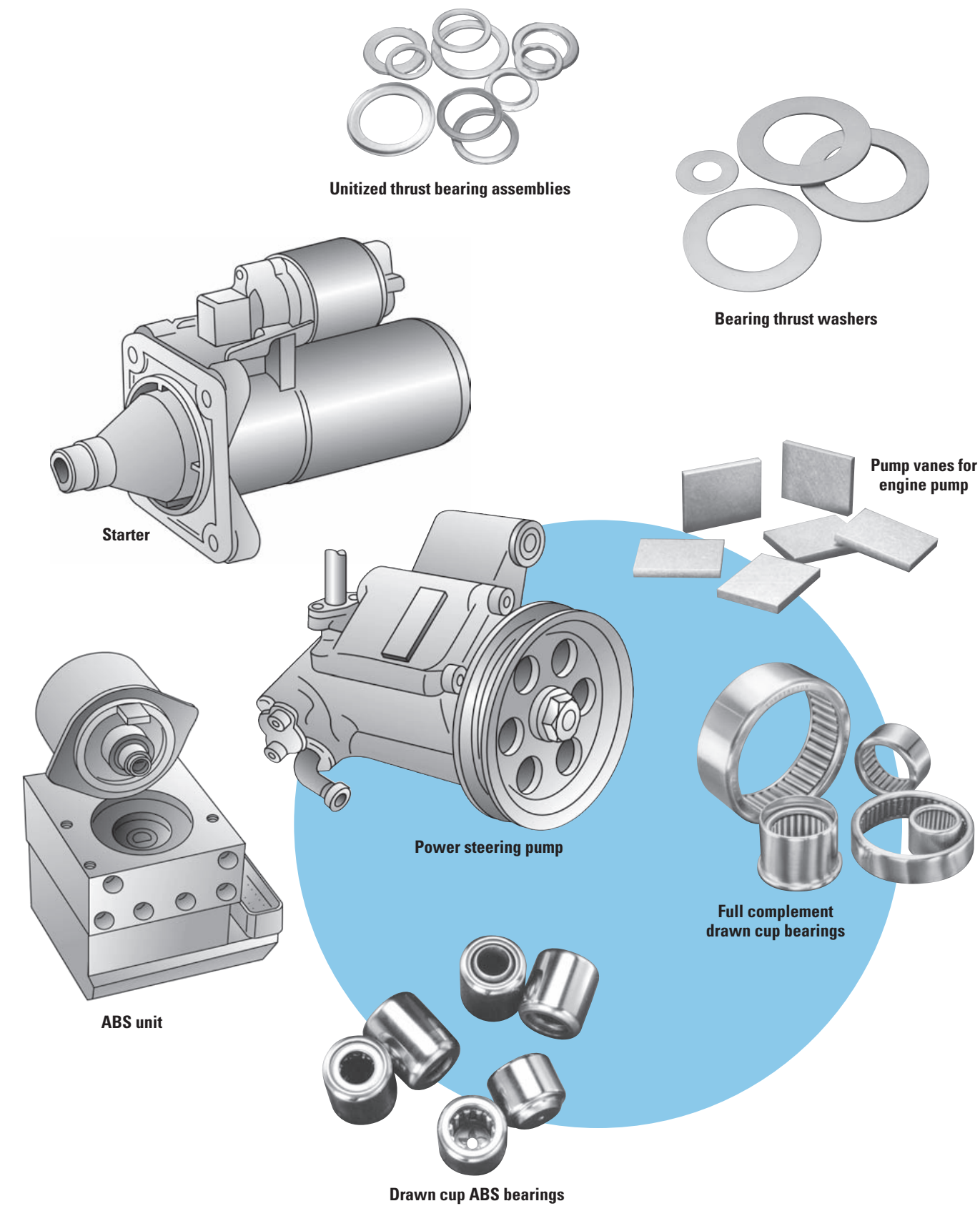
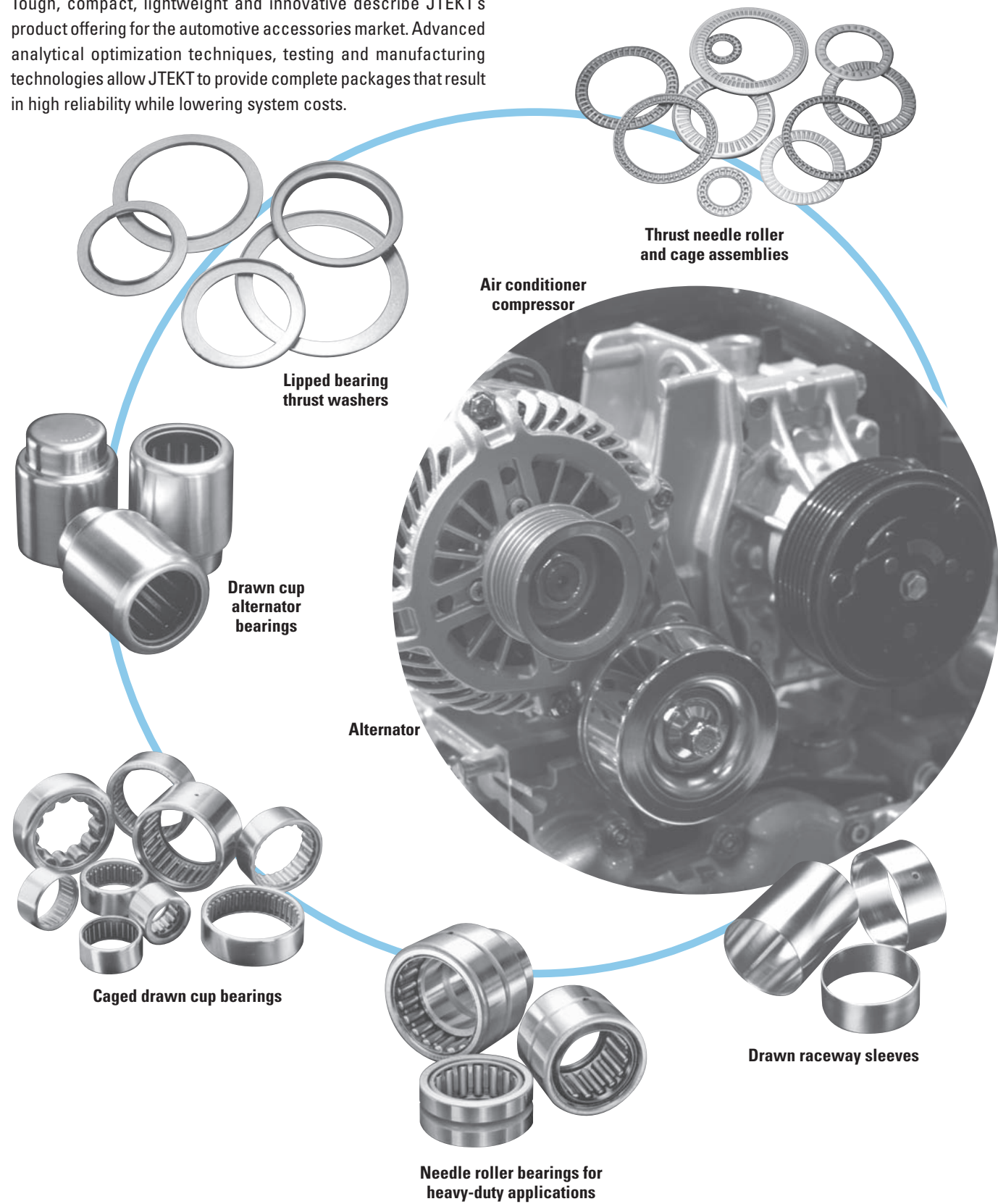

DRIVETRAIN COMPONENTS

JTEKT is a leading supplier of bearings for the harsh environment of drivetrain components. Our heavy wall drawn cup bearing is an industry standard for performance and reliability in semi-float axle applications. With a history of JTEKT's innovative engineering, in-house testing and field experience, vehicle drivetrain engineers can confidently specify JTEKT bearings to meet their design demands.

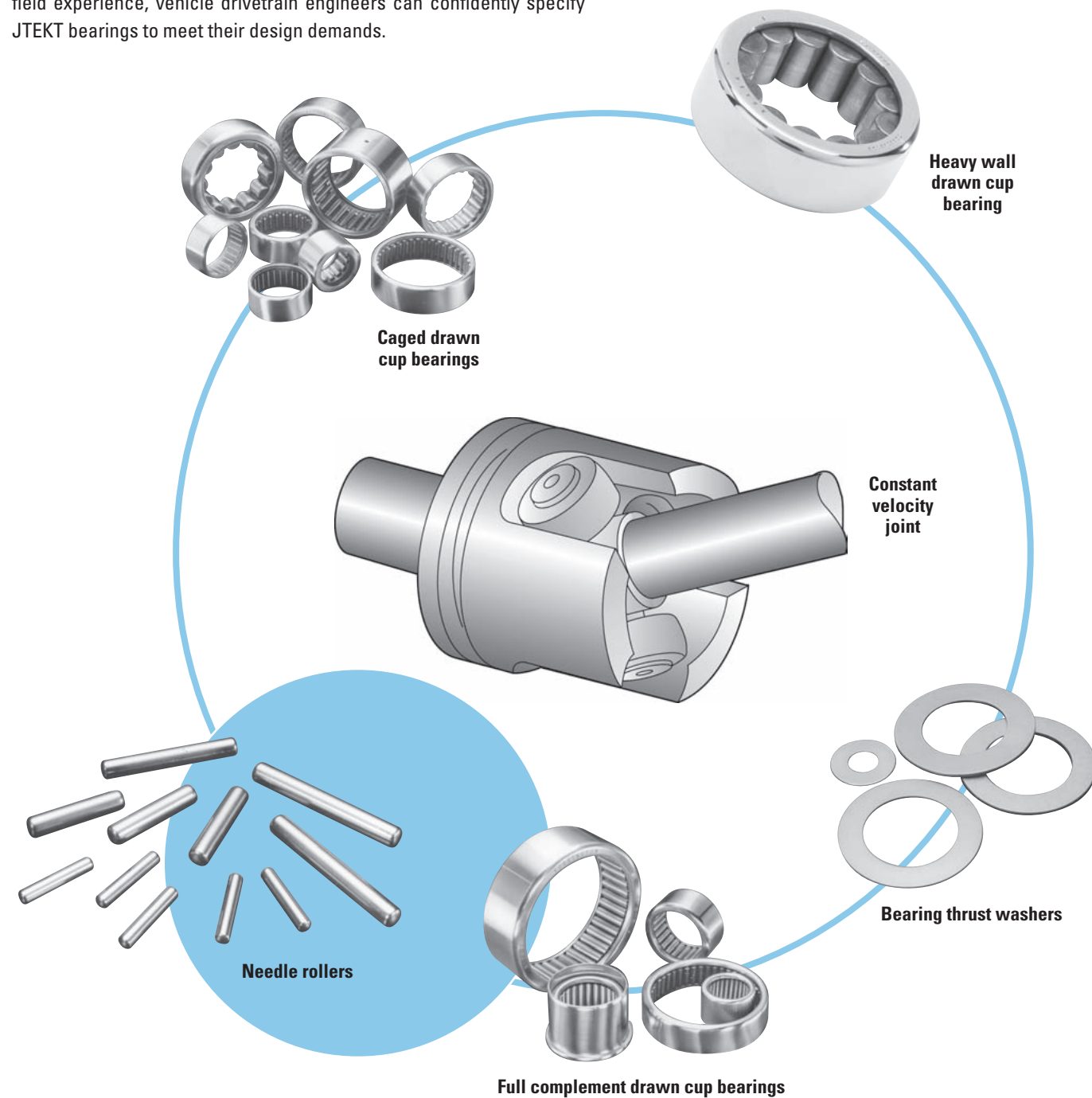

POWER TRANSMISSIONS

Whether supplied as individual components or as unit assemblies, JTEKT offers products that provide maximum load and speed capability within a small envelope. Our compact, efficient and long-life designs allow power transmission builders to increase power density and extend product life while minimizing lubrication demands and reducing overall package size.

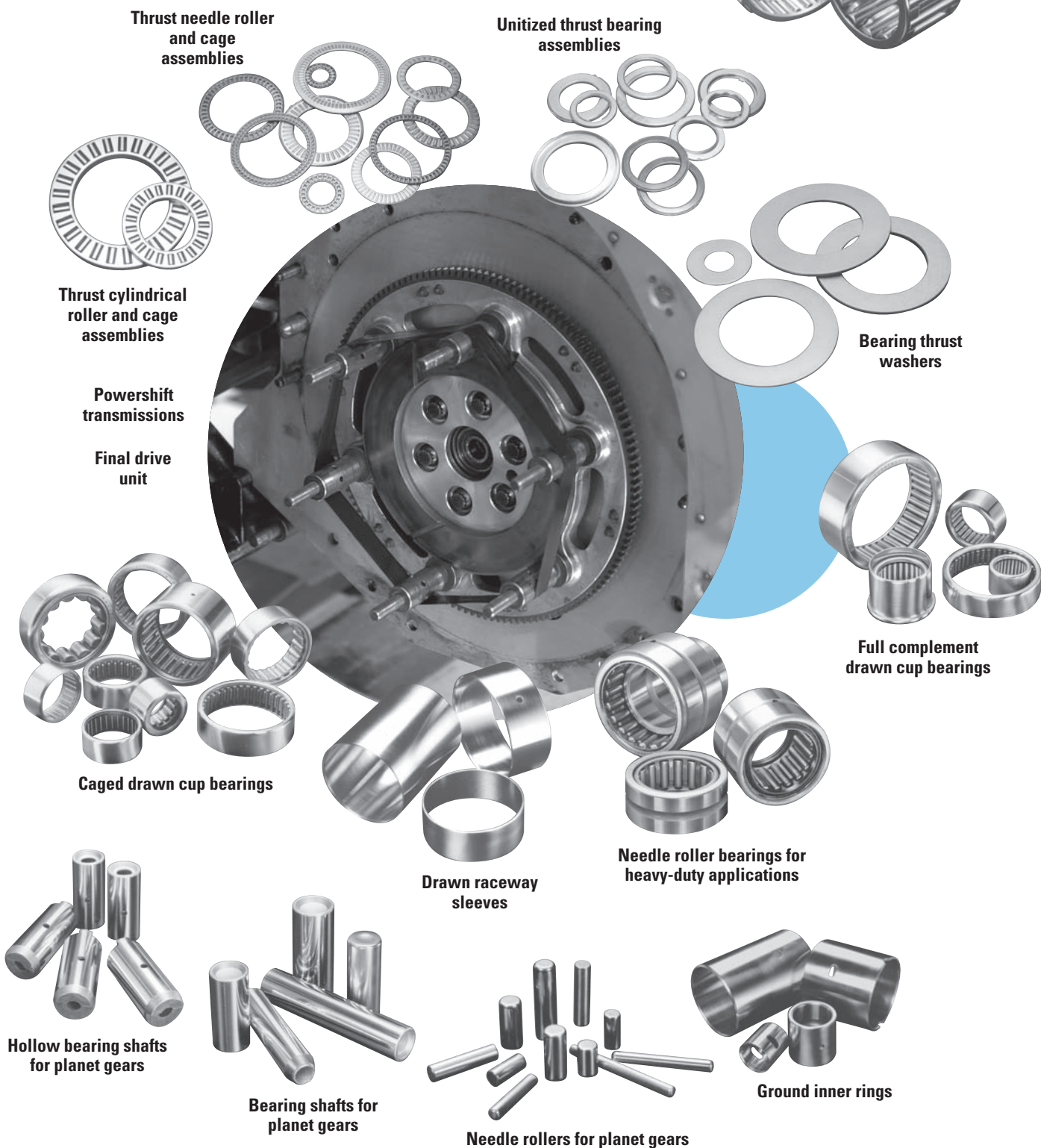

SPORT VEHICLES

In anticipation of the wide range of sport vehicle applications, JTEKT has developed a broad line of reliable, low-profile and low-cost bearing solutions. These designs can be optimized for a wide range of application demands including high speed, high load, temperature extremes or low mass. JTEKT has an engineered solution for your unique and demanding applications.

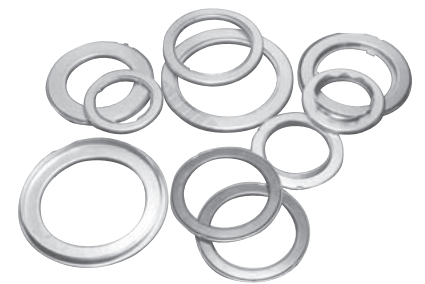

Unitized thrust bearing assemblies

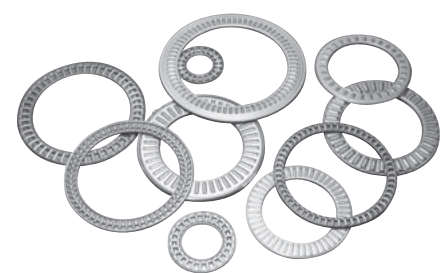

Thrust needle roller and cage assemblies

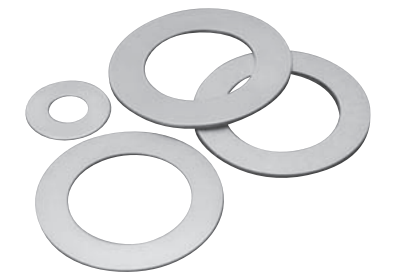

Bearing thrust washers



Radial needle roller and cage assembly

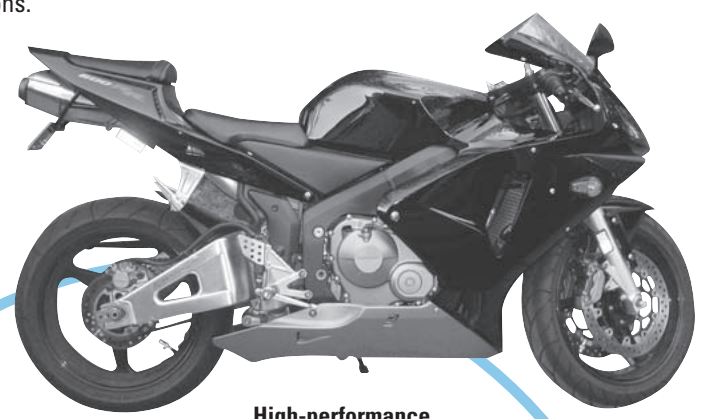

High-performance motorcycle

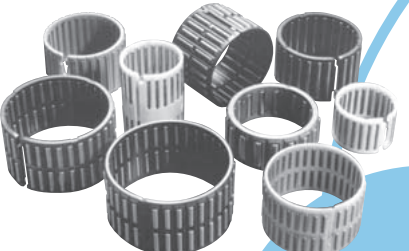

Radial needle roller and cage assemblies (Split polymer type)



Hollow wristpins

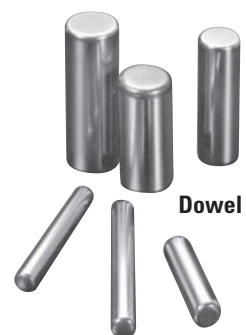

Dowel pins



Roller rocker arms



Off-road motorcycle

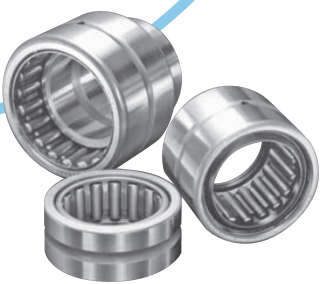

Needle roller bearings for heavy-duty applications



Snowmobile



Ground inner rings



Scooter

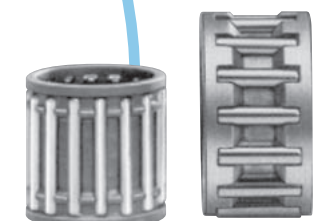

Wrist pin and crank pin bearings



Drawn raceway sleeves

MARINE APPLICATIONS

Split housings, high speeds and limited amounts of lubrication are some of the major design requirements that JTEKT has overcome in successfully designing bearings for marine power head and drivetrain applications. JTEKT's history of supplying this industry proves that tough environmental challenges can be resolved with creative engineering solutions and products at an economical price.

Full complement drawn cup bearings

Needle roller bearings for heavy-duty applications

Caged drawn cup bearings

Cylindrical rollers

Connecting rod and center-main double split liners

Radial needle roller and cage assemblies for crankpins (Split steel or polymer type)

Radial needle roller and cage assemblies for main bearings (Split polymer type)

Caged radial assembly

Outboard motor

Personal watercraft

Unitized thrust bearing assemblies

Thrust needle roller and cage assemblies

Bearing thrust washers

Inboard motor

Wrist pin and crank pin bearings

Outboard motor

Double split outer rings

Ground inner rings

Drawn raceway sleeves

Dowel pins

POWER TOOLS

JTEKT continues to bring lightweight, durable, economical and compact products to the power tool market. We have anticipated customer expectations, become increasingly stringent and have responded with many innovative products. Greater performance within the existing package, subassemblies for more efficient manufacturing, and lubrication enhancing designs make JTEKT bearings the ideal solution for the power tool market.

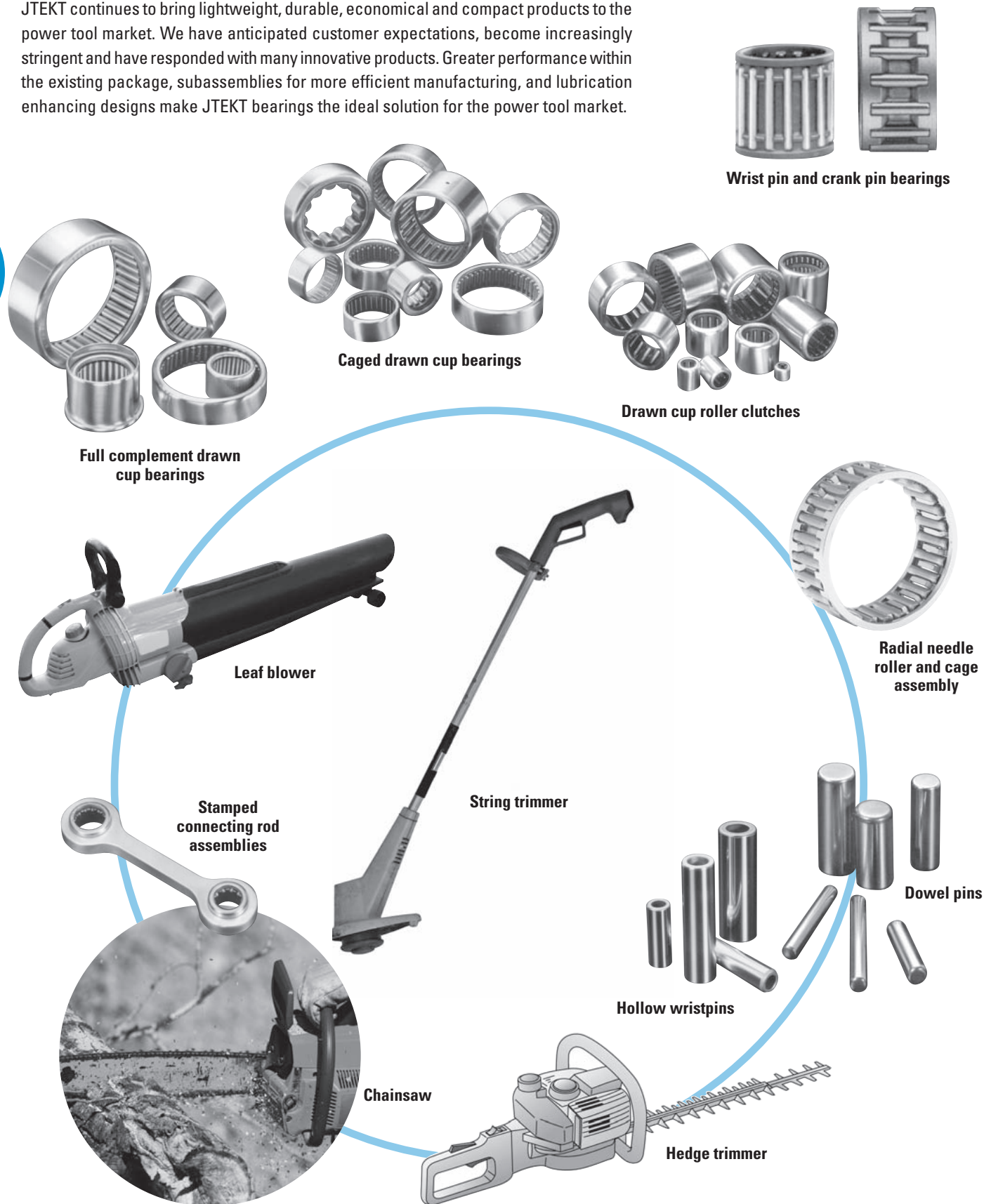

CONSUMER PRODUCTS

Among a vast product offering, JTEKT has design solutions that are ideally matched to the consumer product market. Low friction, light weight, quick assembly and economical designs make JTEKT bearings the product of choice for these diverse applications.

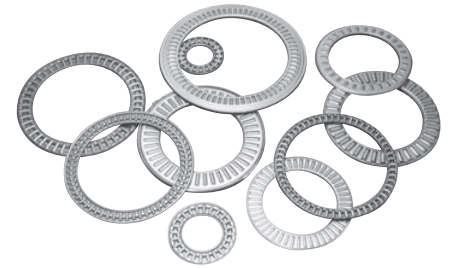
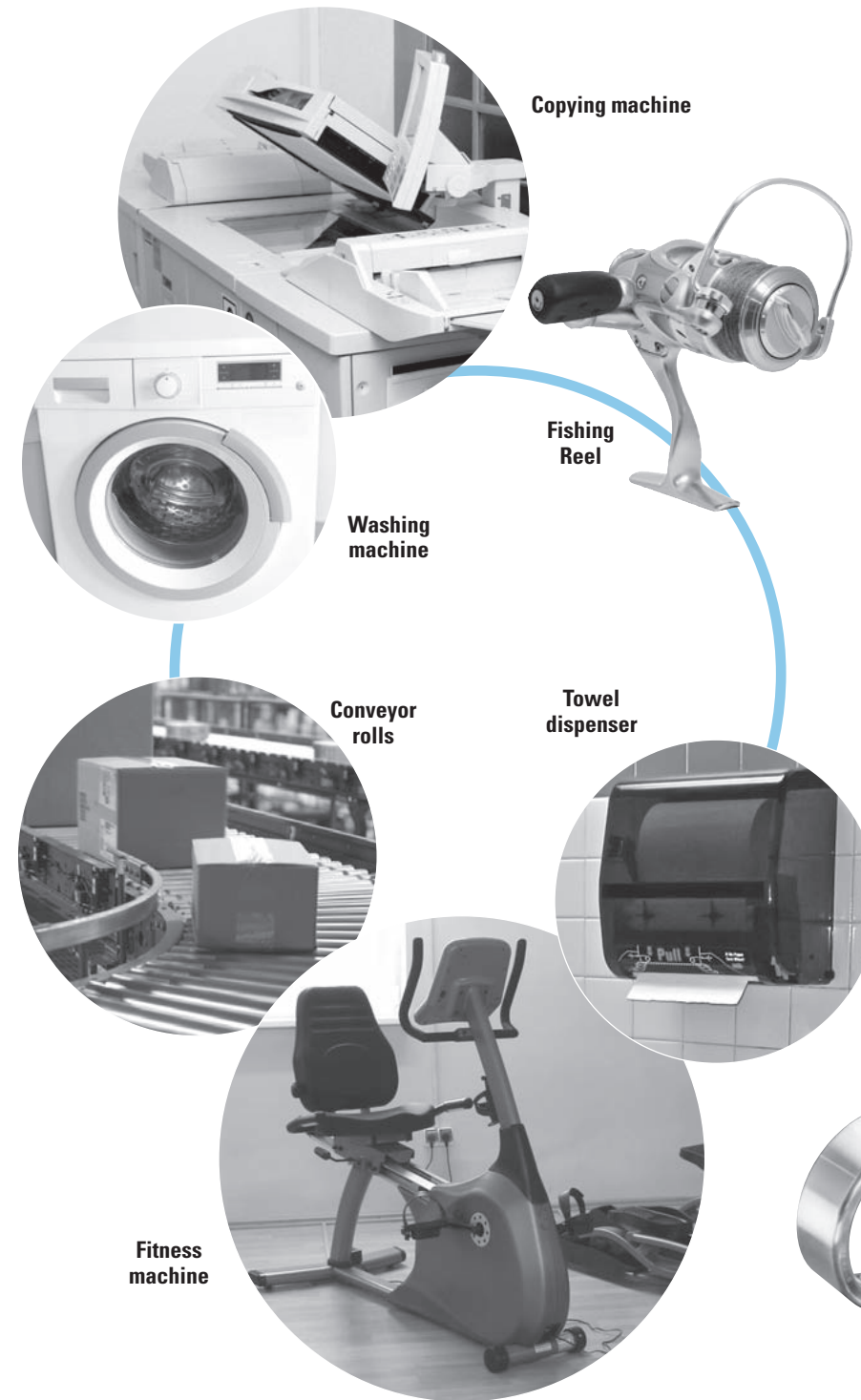

Thrust needle roller and cage assemblies



Bearing thrust washers

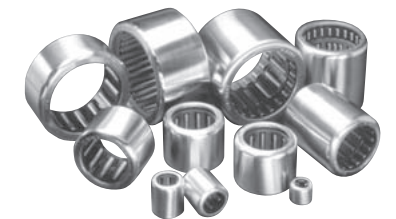

Drawn cup roller clutches



Caged drawn cup bearings



Full complement drawn cup bearings

MECHANICAL PUMPS

Reliable and compact JTEKT bearing designs help pump designers achieve maximum efficiency and reliability in high-pressure industrial applications. Product innovations such as the controlled-stress needle roller bearings provide designers the flexibility they need to tailor their pump packages to meet specific requirements.

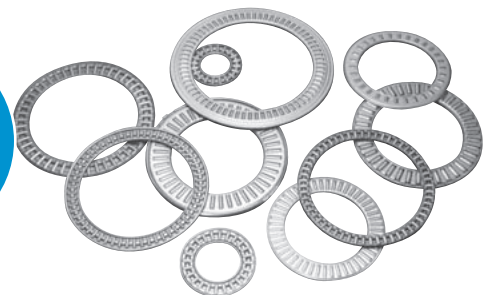

Thrust needle roller and cage assemblies



Bearing thrust washers



Full complement drawn cup bearings



Needle roller bearings for heavy-duty applications



Caged drawn cup bearings

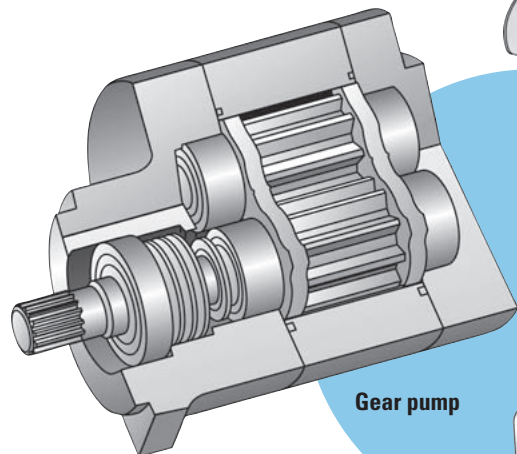

Gear pump

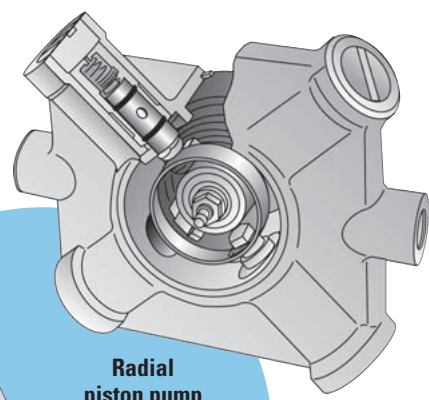

Radial piston pump

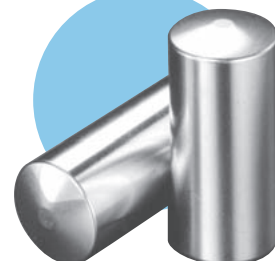

Pistons for hydraulic pumps

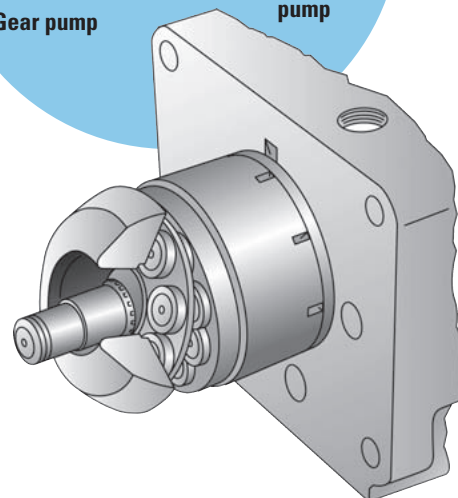

Axial piston pump

INDUSTRIAL MACHINERY

Track rollers provide smooth operation of telescopic masts in fork lift trucks and many heavy lift applications. JTEKT's cylindrical roller thrust bearings and heavy-duty needle roller bearings provide ideal solutions for applications that require high load-carrying capability in small cross sectional areas.



Needle roller bearings for heavy-duty applications

Fork lift truck

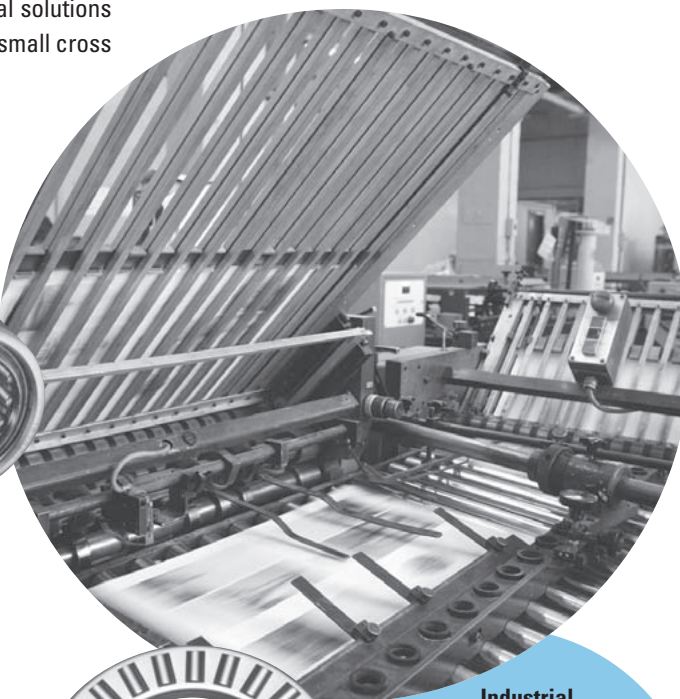

Industrial machines

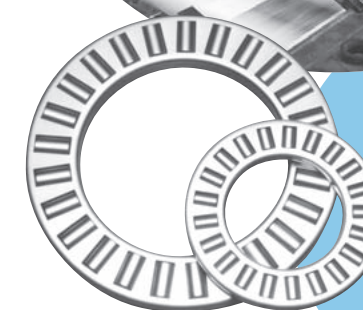

Thrust cylindrical roller and cage assemblies

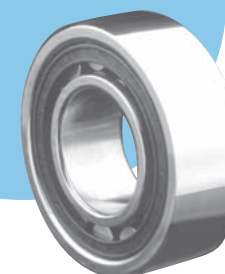

Cylindrical roller bearing



Track rollers





NOTES



SUPPLEMENTARY TABLES

D

D SUPPLEMENTARY TABLES

D

D

SUPPLEMENTARY TABLES



Supplementary Tables

	<i>Page</i>
Conversion Table	D-4
Designation Suffixes	D-8
Symbols and Terms	D-9
Index	D-11



CONVERSION TABLE

STEEL HARDNESS NUMBERS⁽¹⁾

Table D-1. Approximate hardness conversion numbers for steel, based on Rockwell C

Rockwell C-Scale Hardness Number	Diamond Pyramid Hardness Number Vickers	Brinell Hardness Number 10 mm Ball 3000 kg Load			Rockwell Hardness Number			Rockwell Superficial Hardness Number Superficial Brale Penetrator			Shore Scleroscope Hardness Number	Tensile Strength (approx.) MPa	Tensile Strength (approx.) 1000 psi	Rockwell C-Scale Hardness Number
		Standard Ball	Hultgren Ball	Tungsten Carbide Ball	A-Scale 60 kg Load Brale Penetrator	B-Scale 15 kg Load 1/16 in (1.59 mm) Dia.	D-Scale 100 kg Brale Penetrator	15-N Acale 15 kg Load	30-N Scale 30 kg Load	45-N Scale 45 kg Load				
68	940	—	—	—	85.6	—	76.9	93.2	84.4	75.4	97	—	—	68
67	900	—	—	—	85	—	76.1	92.9	83.6	74.2	95	—	—	67
66	865	—	—	—	84.5	—	75.4	92.5	82.8	73.3	92	—	—	66
65	832	—	—	739	83.9	—	74.5	92.2	81.9	72	91	—	—	65
64	800	—	—	722	83.4	—	73.8	91.8	81.1	71	88	—	—	64
63	772	—	—	705	82.8	—	73	91.4	80.1	69.9	87	—	—	63
62	746	—	—	688	82.3	—	72.2	91.1	79.3	68.8	85	—	—	62
61	720	—	—	670	81.8	—	71.5	90.7	78.4	67.7	83	—	—	61
60	697	—	613	654	81.2	—	70.7	90.2	77.5	66.6	81	—	—	60
59	674	—	599	634	80.7	—	69.9	89.8	76.6	65.5	80	2250	326	59
58	653	—	587	615	80.1	—	69.2	89.3	75.7	64.3	78	2170	315	58
57	633	—	575	595	79.6	—	68.5	88.9	74.8	63.2	76	2100	305	57
56	613	—	561	577	79	—	67.7	88.3	73.9	62	75	2030	295	56
55	595	—	546	560	78.5	—	66.9	87.9	73	60.9	74	1980	287	55
54	577	—	534	543	78	—	66.1	87.4	72	59.8	72	1920	278	54
53	560	—	519	525	77.4	—	65.4	86.9	71.2	58.6	71	1850	269	53
52	544	500	508	512	76.8	—	64.6	86.4	70.2	57.4	69	1810	262	52
51	528	487	494	496	76.3	—	63.8	85.9	69.4	56.1	68	1740	253	51
50	513	475	481	481	75.9	—	63.1	85.5	68.5	55	67	1690	245	50
49	498	464	469	469	75.2	—	62.1	85	67.6	53.8	66	1650	239	49
48	484	451	455	455	74.7	—	61.4	84.5	66.7	52.5	64	1600	232	48
47	471	442	443	443	74.1	—	60.8	83.9	65.8	51.4	63	1550	225	47
45	446	421	421	421	73.1	—	59.2	83	64	49	60	1460	212	45
44	434	409	409	409	72.5	—	58.5	82.5	63.1	47.8	58	1420	206	44
43	423	400	400	400	72	—	57.7	82	62.2	46.7	57	1390	201	43
42	412	390	390	390	71.5	—	56.9	81.5	61.3	45.5	56	1350	196	42
41	402	381	381	381	70.9	—	56.2	80.9	60.4	44.3	55	1320	191	41
40	392	371	371	371	70.4	—	55.4	80.4	59.5	43.1	54	1280	186	40
39	382	362	362	362	69.9	—	54.6	79.9	58.6	41.9	52	1250	181	39
38	372	353	353	353	69.4	—	53.8	79.4	57.7	40.8	51	1210	176	38
37	363	344	344	344	68.9	—	53.1	78.8	56.8	39.6	50	1190	172	37
36	354	336	336	336	68.4	(109)	52.3	78.3	55.9	38.4	49	1160	168	36
35	345	327	327	327	67.9	(108.5)	51.5	77.7	55	37.2	48	1120	163	35
34	336	319	319	319	67.4	(108)	50.8	77.2	54.2	36.1	47	1100	159	34
33	327	311	311	311	66.8	(107.5)	50	76.6	53.3	34.9	46	1060	154	33
32	318	301	301	301	66.3	(107)	49.2	76.1	52.1	33.7	44	1030	150	32
31	310	294	294	294	65.8	(106)	48.4	75.6	51.3	32.5	43	1010	146	31
30	302	286	286	286	65.3	(105.5)	47.7	75	50.4	31.3	42	980	142	30
29	294	279	279	279	64.7	(104.5)	47	74.5	49.5	30.1	41	950	138	29
28	286	271	271	271	64.3	(104)	46.1	73.9	48.6	28.9	41	920	134	28
27	279	264	264	264	63.8	(103)	45.2	73.3	47.7	27.8	40	900	131	27
26	272	258	258	258	63.3	(102.5)	44.6	72.8	46.8	26.7	38	880	127	26
25	266	253	253	253	62.8	(101.5)	43.8	72.2	45.9	25.5	38	850	124	25
24	260	247	247	247	62.4	(101)	43.1	71.6	45	24.3	37	830	121	24
23	254	243	243	243	62	100	42.1	71	44	23.1	36	810	118	23
22	248	237	237	237	61.5	99	41.6	70.5	43.2	22	35	790	115	22
21	243	231	231	231	61	98.5	40.9	69.9	42.3	20.7	35	780	113	21
20	238	226	226	226	60.5	97.8	40.1	69.4	41.5	19.6	34	760	110	20

(1) Source ASTM

CONVERSION TABLE

TO CONVERT FROM	TO	MULTIPLY BY
Acceleration		
foot/second ²	meter/second ²	m/s ² 0.3048
inch/second ²	meter/second ²	m/s ² 0.0254
Area		
foot ²	meter ²	m ² 0.09290304
inch ²	meter ²	m ² 0.00064516
inch ²	millimeter ²	mm ² 645.16
yard ²	meter ²	m ² 0.836127
mile ² (U.S. statute)	meter ²	m ² 2589988
Bending Moment or Torque		
dyne-centimeter	newton-meter	N-m..... 0.000001
kilogram-force-meter	newton-meter	N-m..... 9.806650
pound-force-inch	newton-meter	N-m..... 0.1129848
pound-force-foot	newton-meter	N-m..... 1.355818
Energy		
BTU (International Table)	joule	J..... 1055.056
foot-pound-force	joule	J..... 1.355818
kilowatt-hour	megajoule	MJ..... 3.6
Force		
kilogram-force	newton	N..... 9.806650
kilopound-force	newton	N..... 9.806650
pound-force (lbf avoirdupois)	newton	N..... 4.448222
Length		
fathom	meter	m..... 1.8288
foot	meter	m..... 0.3048
inch	millimeter	mm..... 25.4
microinch	micrometer	µm..... 0.0254
micron (µm)	millimeter	mm..... 0.0010
mile (U.S. statute)	meter	m..... 1609.344
yard	meter	m..... 0.9144
nautical mile (UK)	meter	m..... 1853.18
Mass		
kilogram-force-second ² /meter (mass)	kilogram	kg..... 9.806650
kilogram-mass	kilogram	kg..... 1.0
pound-mass (lbm avoirdupois)	kilogram	kg..... 0.4535924
ton (long, 2240 lbm)	kilogram	kg..... 1016.047
ton (short, 2000 lbm)	kilogram	kg..... 907.1847
tonn.	kilogram	kg..... 1000.000
Power		
BTU (International Table)/hour	watt	W..... 0.293071
BTU (International Table)/minute	watt	W..... 17.58427
horsepower (550 ft lbf/s)	kilowatt	kW..... 0.745700
BTU (thermochemical)/minute	watt	W..... 17.57250
Pressure or Stress (Force/Area)		
newton/meter ²	pascal	Pa..... 1.0000
kilogram-force/centimeter ²	pascal	Pa..... 98066.50
kilogram-force/meter ²	pascal	Pa..... 9.806650
kilogram-force/millimeter ²	pascal	Pa..... 9806650
pound-force/foot ²	pascal	Pa..... 47.88026
pound-force/inch ² (psi)	megapascal	MPa..... 0.006894757
Temperature		
degree Celsius	kelvin	k..... t _k = t _c + 273.15
degree Fahrenheit	kelvin	k..... k = 5/9 (t _f + 459.67)
degree Fahrenheit	Celsius	°C..... t _c = 5/9 (t _f - 32)
Velocity		
foot/minute	meter/second	m/s..... 0.00508
foot/second	meter/second	m/s..... 0.3048
inch/second	meter/second	m/s..... 0.0254
kilometer/hour	meter/second	m/s..... 0.27778
mile/hour (U.S. statute)	meter/second	m/s..... 0.44704
mile/hour (U.S. statute)	kilometer/hour	km/h..... 1.609344
Volume		
foot ³	meter ³	m ³ 0.02831685
gallon (U.S. liquid)	liter	l..... 3.785412
liter	meter ³	m ³ 0.001
inch ³	meter ³	m ³ 0.00001638706
inch ³	centimeter ³	cm ³ 16.38706
inch ³	millimeter ³	mm ³ 16387.06
ounce (U.S. fluid)	centimeter ³	cm ³ 29.57353
yard ³	meter ³	m ³ 0.7645549

VISCOSITY CONVERSION TABLE

SUS Saybolt (sec.)	R" Redwood (sec.)	E Engler (deg.)	cSt Centistokes (mm ² /s)
35	32.2	1.18	2.7
40	36.2	1.32	4.3
45	40.6	1.46	5.9
50	44.9	1.60	7.4
55	49.1	1.75	8.9
60	53.5	1.88	10.4
65	57.9	2.02	11.8
70	62.3	2.15	13.1
75	67.6	2.31	14.5
80	71.0	2.42	15.8
85	75.1	2.55	17.0
90	79.6	2.68	18.2
95	84.2	2.81	19.4
100	88.4	2.95	20.6
110	97.1	3.21	23.0
120	105.9	3.49	25.0
130	114.8	3.77	27.5
140	123.6	4.04	29.8
150	132.4	4.32	32.1
160	141.1	4.59	34.3
170	150.0	4.88	36.5
180	158.8	5.15	38.8
190	167.5	5.44	41.0
200	176.4	5.72	43.2
220	194.0	6.28	47.5
240	212	6.85	51.9
260	229	7.38	56.5
280	247	7.95	60.5
300	265	8.51	64.9
325	287	9.24	70.3
350	309	9.95	75.8
375	331	10.7	81.2
400	353	11.4	86.8
425	375	12.1	92.0
450	397	12.8	97.4
475	419	13.5	103
500	441	14.2	108
550	485	15.6	119
600	529	17.0	130
650	573	18.5	141
700	617	19.9	152
750	661	21.3	163
800	705	22.7	173
850	749	24.2	184
900	793	25.6	195
950	837	27.0	206
1000	882	28.4	217
1200	1058	34.1	260
1400	1234	39.8	302
1600	1411	45.5	347
1800	1587	51	390
2000	1763	57	433
2500	2204	71	542
3000	2646	85	650
3500	3087	99	758
4000	3526	114	867
4500	3967	128	974
5000	4408	142	1082
5500	4849	156	1150
6000	5290	170	1300
6500	5730	185	1400
7000	6171	199	1510
7500	6612	213	1630
8000	7053	227	1740
8500	7494	242	1850
9000	7934	256	1960
9500	8375	270	2070
10000	8816	284	2200



CONVERSION TABLE

INCH FRACTIONS TO DECIMALS AND MILLIMETERS

4ths	8ths	16ths	32nds	64ths	Inches	millimeters	4ths	8ths	16ths	32nds	64ths	Inches	millimeters
			$\frac{1}{64}$.015625	0.3969					$\frac{33}{64}$.515625	13.0969
			$\frac{1}{32}$.03125	0.7937				$\frac{17}{32}$.53125	13.4937
				$\frac{3}{64}$.046875	1.1906					$\frac{39}{64}$.546875	13.8906
		$\frac{1}{16}$.0625	1.5875			$\frac{9}{16}$.5625	14.2875
				$\frac{5}{64}$.078125	1.9844					$\frac{37}{64}$.578125	14.6844
			$\frac{3}{32}$.09375	2.3812				$\frac{19}{32}$.59375	15.0812
				$\frac{7}{64}$.109375	2.7781					$\frac{39}{64}$.609375	15.4781
	$\frac{1}{8}$.125	3.1750		$\frac{5}{8}$			$\frac{41}{64}$.625	15.8750
				$\frac{9}{64}$.140625	3.5719						.640625	16.2719
			$\frac{5}{32}$.15625	3.9685				$\frac{21}{32}$.65625	16.6687
				$\frac{11}{64}$.171875	4.3656					$\frac{43}{64}$.671875	17.0656
			$\frac{3}{16}$.1875	4.7625			$\frac{11}{16}$.6875	17.4625
				$\frac{13}{64}$.203125	5.1594					$\frac{45}{64}$.703125	17.8594
			$\frac{7}{32}$.21875	5.5562				$\frac{23}{32}$.71875	18.2562
				$\frac{15}{64}$.234375	5.9531					$\frac{47}{64}$.734375	18.6531
$\frac{1}{4}$.250	6.3500	$\frac{3}{4}$.750	19.0500
				$\frac{17}{64}$.265625	6.7459					$\frac{49}{64}$.765625	19.4459
			$\frac{9}{32}$.28125	7.1438				$\frac{25}{32}$.78125	19.8437
				$\frac{19}{64}$.296875	7.5406					$\frac{51}{64}$.796875	20.2406
	$\frac{5}{16}$.3125	7.9375			$\frac{13}{16}$.8125	20.6375
				$\frac{21}{64}$.328125	8.3344					$\frac{53}{64}$.828125	21.0344
			$\frac{11}{32}$.34375	8.7312				$\frac{27}{32}$.84375	21.4312
				$\frac{23}{64}$.359375	9.1281					$\frac{55}{64}$.859375	21.8281
	$\frac{3}{8}$.375	9.5250		$\frac{7}{8}$.875	22.2250
				$\frac{25}{64}$.390625	9.9219					$\frac{57}{64}$.890625	22.6219
			$\frac{13}{32}$.40625	10.3187				$\frac{29}{32}$.90625	23.0187
				$\frac{27}{64}$.421875	10.7156					$\frac{59}{64}$.921875	23.4156
	$\frac{7}{16}$.4375	11.1125			$\frac{15}{16}$.9375	23.8125
				$\frac{29}{64}$.453125	11.5094					$\frac{61}{64}$.953125	24.2094
			$\frac{15}{32}$.46875	11.9062				$\frac{31}{32}$.96875	24.6062
				$\frac{31}{64}$.484375	12.3031					$\frac{63}{64}$.984375	25.0031
					.500	12.7000						1.000	25.4000

ROUNDING OFF

- If the figure beyond the last figure to be retained is less than five, the last figure retained should not be changed.
- If the figures beyond the last figure to be retained amount to more than five, the last figure retained should be increased by one.
- If the figure beyond the last figure to be retained is five, followed by zeros, and the last figure to be retained is an "even" number, it should be unchanged; if it is "odd" it should be increased by one.

CONVERSION TABLE

Table D-2. Inches to millimeters – units

inches		0	1	2	3	4	5	6	7	8	9
0	0.0000	0.000	25.400	50.800	76.200	101.600	127.000	152.400	177.800	203.200	228.600
1/16	0.0625	1.588	26.988	52.388	77.788	103.188	128.588	153.988	179.388	204.788	230.188
1/8	0.1250	3.175	28.575	53.975	79.375	104.775	130.175	155.575	180.975	206.375	231.775
3/16	0.1875	4.763	30.162	55.562	80.962	106.362	131.762	157.162	182.562	207.962	233.362
1/4	0.2500	6.350	31.750	57.150	82.550	107.950	133.350	158.750	184.150	209.550	234.950
5/16	0.3125	7.938	33.338	58.738	84.138	109.538	134.938	160.338	185.735	211.138	236.538
3/8	0.3750	9.525	34.925	60.325	85.725	111.125	136.525	161.925	187.325	212.725	238.125
7/16	0.4375	11.112	36.512	61.912	87.312	112.712	138.112	163.512	188.912	214.312	239.712
1/2	0.5000	12.700	38.100	63.500	88.900	114.300	139.700	165.100	190.500	215.900	241.300
9/16	0.5625	14.288	39.688	65.088	90.488	115.888	141.288	166.688	192.088	217.488	242.888
5/8	0.6250	15.875	41.275	66.675	92.075	117.475	142.875	168.275	193.675	219.075	244.475
11/16	0.6875	17.462	42.862	68.262	93.662	119.062	144.462	169.862	195.262	220.662	246.062
3/4	0.7500	19.050	44.450	69.850	95.250	120.650	146.050	171.450	196.850	222.250	247.650
13/16	0.8125	20.638	46.038	71.438	96.838	122.238	147.638	173.038	198.438	223.838	249.238
7/8	0.8750	22.225	47.625	73.025	98.425	123.825	149.225	174.625	200.025	225.425	250.825
15/16	0.9375	23.812	49.212	74.612	100.012	125.412	150.812	176.212	201.612	227.012	252.412

inches		10	11	12	13	14	15
0	0.0000	254.000	279.400	304.800	330.200	355.600	381.000
1/16	0.0625	255.588	280.988	306.388	331.788	357.188	382.588
1/8	0.1250	257.175	282.575	307.975	333.375	358.775	384.175
3/16	0.1875	258.762	284.162	309.562	334.962	360.362	385.762
1/4	0.2500	260.350	285.750	311.150	336.550	361.950	387.350
5/16	0.3125	261.938	287.338	312.738	338.138	363.538	388.938
3/8	0.3750	263.525	288.925	314.325	339.725	365.125	390.525
7/16	0.4375	265.112	290.512	315.912	341.312	366.712	392.112
1/2	0.5000	266.700	292.100	317.500	342.900	368.300	393.700
9/16	0.5625	268.288	293.688	319.088	344.488	369.888	395.288
5/8	0.6250	269.875	295.275	320.675	346.075	371.475	396.875
11/16	0.6875	271.462	296.862	322.262	347.662	373.062	398.462
3/4	0.7500	273.050	298.450	323.850	349.250	374.650	400.050
13/16	0.8125	274.638	300.038	325.438	350.838	376.238	401.638
7/8	0.8750	276.225	301.625	327.025	352.425	377.825	403.225
15/16	0.9375	277.812	303.212	328.612	354.012	379.412	404.812

B.S.I. Norm No. 350
A.S.A. Norm No. B48.1 } 1 inch = 25.400 mm (exact)

DIN 4890, 1 mm = $\frac{1}{25.4}$ inches



Table D-3. Units

inches	10	
0	—	254
1	25.4	279.4
2	50.8	304.8
3	76.2	330.2
4	101.6	355.6
5	127	381
6	152.4	406.4
7	177.8	431.8
8	203.2	457.2
9	228.6	482.6

Table D-4. Fractions

1/10"		1/100"		1/1000"		1/10000"	
inches	mm	inches	mm	inches	mm	inches	mm
0.1	2.54	0.01	0.254	0.001	0.0254	0.0001	0.00254
0.2	5.08	0.02	0.508	0.002	0.0508	0.0002	0.00508
0.3	7.62	0.03	0.762	0.003	0.0762	0.0003	0.00762
0.4	10.16	0.04	1.016	0.004	0.1016	0.0004	0.01016
0.5	12.70	0.05	1.270	0.005	0.1270	0.0005	0.01270
0.6	15.24	0.06	1.524	0.006	0.1524	0.0006	0.01524
0.7	17.78	0.07	1.778	0.007	0.1778	0.0007	0.01778
0.8	20.32	0.08	2.032	0.008	0.2032	0.0008	0.02032
0.9	22.86	0.09	2.286	0.009	0.2286	0.0009	0.02286

Table D-5. Millimeters to Inches – Units

mm	10	20	30	40	50	60	70	80	90	
0	—	0.39370	0.78740	1.18110	1.57480	1.96850	2.36220	2.75591	3.14961	3.54331
1	0.03937	0.43307	0.82677	1.22047	1.61417	2.00787	2.40157	2.79528	3.18898	3.58268
2	0.07874	0.47244	0.86614	1.25984	1.65354	2.04724	2.44094	2.83465	3.22835	3.62205
3	0.11811	0.51181	0.90551	1.29921	1.69291	2.08661	2.48031	2.87402	3.26772	3.66142
4	0.15748	0.55118	0.94488	1.33858	1.73228	2.12598	2.51969	2.91339	3.30709	3.70079
5	0.19685	0.59055	0.98425	1.37795	1.77165	2.16535	2.55906	2.95276	3.34646	3.74016
6	0.23622	0.62992	1.02362	1.41732	1.71102	2.20472	2.59843	2.99213	3.38583	3.77953
7	0.27559	0.66929	1.06299	1.45669	1.85039	2.24409	2.63780	3.03150	3.42520	3.81890
8	0.31496	0.70866	1.10236	1.49606	1.88976	2.28346	2.67717	3.07087	3.46457	3.85827
9	0.35433	0.74803	1.14173	1.53543	1.92913	2.32283	2.71654	3.11024	3.50394	3.89764

Table D-6. Millimeters to Inches – Units

mm	100	200	300	
0	—	3.93701	7.87402	11.81100
10	0.39370	4.33071	8.26772	12.20470
20	0.78740	4.72441	8.66142	12.59840
30	1.18110	5.11811	9.05512	12.99210
40	1.57480	5.51181	9.44882	13.38580
50	1.96850	5.90551	9.84252	13.77950
60	2.36220	6.29921	10.23620	14.17320
70	2.75591	6.69291	10.62990	14.56690
80	3.14961	7.08661	11.02360	14.96060
90	3.54331	7.48031	11.41730	15.35430

Table D-7. Fractions

1/10 mm		1/100 mm		1/1000 mm	
mm	inches	mm	inches	mm	inches
0.1	0.00394	0.01	0.00039	0.001	0.00039
0.2	0.00787	0.02	0.00079	0.002	0.00079
0.3	0.01181	0.03	0.00118	0.003	0.00118
0.4	0.01575	0.04	0.00157	0.004	0.00157
0.5	0.01969	0.05	0.00197	0.005	0.00197
0.6	0.02362	0.06	0.00236	0.006	0.00236
0.7	0.02756	0.07	0.00276	0.007	0.00276
0.8	0.03150	0.08	0.00315	0.008	0.00315
0.9	0.03543	0.09	0.00354	0.009	0.00354

DESIGNATION SUFFIXES

Suffix	Description	Applies to
.2RS	Two seals	Metric series: Needle roller bearings; drawn cup needle roller bearings; track rollers. Inch series: Needle roller bearings
2SK	Hexagonal wrench socket in both flange stud ends	Metric series: Track roller – stud-type
AS1	One lubricating hole in the outer ring	Metric series: Drawn cup needle roller bearings
BE	Radial needle roller and cage assembly for crank pin applications	Metric series: Radial needle roller and cage assembly
DZ	Cylindrical outer diameter	Metric series: Track rollers
EE	Two polymer shields	Metric series: Track rollers (types FG, GC, GCR)
EEM	Two metal shields	Metric series: Track rollers (types FG, GC, GCR)
F	Machined cage	Metric series: Radial needle roller and cage assembly
F	Plastic cage	Inch series: Drawn cup needle roller bearing
FH	Machined cage, case hardened	Metric series: Radial needle roller and cage assembly
FS	Single roller per pocket, stainless steel spring (red cage)	Inch series: Drawn cup clutch
G2, G3, G5	Roller diameter tolerance grade	Metric series: Needle rollers
GF	Grease fitting in closed end	Inch series: Drawn cup needle roller bearings
H	Hardened steel cage	Metric series: Radial needle roller and cage assembly
JS1	Lubricating hole in the inner ring	Metric series: Inner ring
K	Light series clutch	Metric series: Drawn cup clutch
L	.005 in width tolerance	Inch series: Inner rings (with four-digit number)
LPB	Machined light metal window-type cage	Metric series: Cylindrical roller thrust bearings
M#	Roller gage, minus	Metric series: Needle rollers, cylindrical rollers
MM	Two metal shields	Metric series: Track rollers (types FG, GC, GCR)
OH	Lubrication hole	Inch series: Drawn cup needle roller bearings, inner rings
OHE	Lubrication hole in closed end	Inch series: Drawn cup needle roller bearings
P	Meets ISO 492 tolerance	Metric series: Inner ring (type IM)
P, P#	Roller gage, 0 or plus	Metric series: Needle rollers, cylindrical rollers
R6	Crowned raceway	Metric series: Inner ring (type IM)
RS	One seal	Metric series: Needle roller bearings, drawn cup needle roller bearings. Inch Series: Needle roller bearings
SE	Radial needle roller and cage assembly for wrist pin applications	Metric series: Radial needle roller and cage assembly
SK	Hexagonal wrench socket in flange end	Metric series: Track roller – stud-type
TB	Bore diameter of needle roller complement set to the lower half of F6 tolerance	Metric series: Combined bearings (types RAX400, RAX500)
TC	Bore diameter of needle roller complement set to the upper half of F6 tolerance	Metric series: Combined bearings (types RAX400, RAX500)
TN	Molded cage of reinforced engineered polymer	Metric series: Needle roller bearings, radial needle roller and cage assemblies, track rollers
TVP	Molded window-type cage of glass-reinforced nylon	Metric series: Cylindrical roller thrust bearings
VH	Machined cage, hardened and tempered	Metric series: Radial needle roller and cage assembly
Z	Shielded and retained with a dust cap	Metric series: Combined bearings
ZW	Double row of rollers	Metric series: Radial needle roller and cage assembly
ZZ	Two end washers for the outer ring	Metric series: Track rollers – yoke-type

SYMBOLS AND TERMS

Symbol	Term	Units	Symbol	Term	Units
α	Nominal contact angle of a bearing (in a typical radial bearing $\alpha = 0^\circ$, in a typical thrust bearing $\alpha = 90^\circ$)	degrees	Δd_{mp}	Deviation of mean bore diameter in a single plane $\Delta d_{mp} = d_{mp} - d$	mm, in
a_1	Reliability life factor	unitless	ΔD_{mp}	Deviation of mean outer diameter in a single plane $\Delta D_{mp} = D_{mp} - D$	mm, in
a_2	Material life factor	unitless	d_{mb}	Mean diameter of a bearing $(d + D)/2$	mm, in
a_3	Operating conditions life factor	unitless	d_{mp}	Mean bore diameter in a single plane $d_{mp} = (d_{sp \max} + d_{sp \min})/2$	mm, in
a_{3d}	Debris life factor	unitless	D_{mp}	Mean outer diameter in a single plane $D_{mp} = (D_{sp \max} + D_{sp \min})/2$	mm, in
a_{3h}	Hardness life factor	unitless	D_{pw}	Pitch diameter of rolling element complement	mm, in
a_{3k}	Load zone life factor	unitless	d_s, d_{sp}	Single bore diameter	mm, in
a_{3l}	Lubrication life factor	unitless	D_s, D_{sp}	Single outer diameter	mm, in
a_{3m}	Misalignment life factor	unitless	D_w	Nominal needle roller diameter	mm, in
a_{3p}	Low load life factor	unitless	D_{we}	Needle roller diameter applicable in the calculation of load ratings	mm, in
B	Nominal inner ring width, nominal bearing width, nominal roller thrust bearing (with washers) thickness	mm, in	E_a	Nominal raceway contact outer diameter for a thrust needle/cylindrical roller and cage assembly	mm, in
B_c	Cage width of radial roller and cage assembly	mm, in	E_b	Nominal raceway contact inside diameter for a thrust needle/cylindrical roller and cage assembly	mm, in
B_s	Single inner ring width	mm, in	E_w	Nominal outer diameter of rolling element complement	mm, in
C	Basic dynamic load rating, radial or axial	kN, lbf	F	Load on bearing	kN, lbf
C	Nominal outer ring width	mm, in	F	Nominal outer diameter on an inner ring	mm, in
C_a	Basic dynamic axial load rating, per ISO 281	kN, lbf	F_a	Bearing axial load	kN, lbf
cc	Total circumferential clearance	mm, in	F_{az}	Bearing allowable axial load	kN, lbf
C_0	Basic static radial load rating, per ISO 76	kN, lbf	f_b	Bearing type factor for determining lubrication interval	unitless
C_{0a}	Basic static axial load rating, per ISO 76	kN, lbf	f_c	Bearing geometry factor, ref. ISO 281	unitless
C_r	Basic dynamic radial load rating, per ISO 281	kN, lbf	$F_{Or \text{ perm}}$	Maximum permissible static load for a track roller	kN, lbf
C_s	Single outer ring width	mm, in	F_r	Bearing radial load	kN, lbf
C_w	Dynamic radial load rating for a track roller	kN, lbf	$F_{r \text{ perm}}$	Maximum permissible radial load for a track roller	kN, lbf
d	Nominal bore diameter of a bearing inner ring or shaft piloted thrust washer	mm, in	F_w	Nominal bore diameter of rolling element complement	mm, in
D	Nominal outer diameter of a bearing outer ring or housing piloted thrust washer	mm, in	$F_{ws \text{ min}}$	The smallest of the single bore diameters of the rolling element complement	mm, in
D_1	Nominal inside diameter of a housing piloted thrust washer	mm, in	G	Stud-type track roller threads	threads
d_1	Nominal stud diameter (stud-type track roller/cam follower)	mm, in	G_r	Radial internal clearance (bearing capable of taking purely radial load, non-preloaded)	mm, in
d_1	Nominal outer diameter of a shaft piloted thrust washer	mm, in	h	Nominal thrust washer thickness	mm, in
d_a	Clamping diameter (yoke- or stud-type track roller/cam follower)	mm, in	H	Cylindrical roller bearing outer ring rib diameter	mm, in
d_b	Housing bore diameter for stud (stud-type track roller/cam follower)	mm, in	H	Housing bore diameter	mm, in
d_m	Mean bearing diameter	mm, in	HF_s	Static load rating adjustment factor for raceway hardness	unitless
ΔB_s	Deviation of a single inner ring width $\Delta B_s = B_s - B$	mm, in	i	Number of rows of rollers in a bearing	unitless
D_c	Nominal outer diameter of a thrust needle roller and cage assembly	mm, in	l	Thrust needle roller approximate length	mm, in
D_{c1}	Nominal bore of a thrust needle roller and cage assembly	mm, in	K	Chordal factor [$K = 1/\sin(180^\circ/Z)$]	unitless
ΔC_s	Deviation of a single outer ring width $\Delta C_s = C_s - C$	mm, in			

SYMBOLS AND TERMS

Symbol	Term	Units	Symbol	Term	Units
K_a	Mounting overhang space (stud type track roller/cam follower)	mm, in	S_d	Deviation from perpendicularity of inner ring face with respect to the bore (previously known as runout of inner ring face with respect to the bore)	mm, in
K_{ea}	Radial runout of outer ring of assembled (radial) bearing	mm, in	S_D	Deviation from perpendicularity of outer ring outside surface generatrix with respect to the face	mm, in
K_{ia}	Radial runout of inner ring of assembled (radial) bearing	mm, in	S_e	Variation in thickness between housing washer raceway and back face (thrust bearing, flat back face)	mm, in
λ	Ratio of lubricant film thickness (in the contact) to the composite surface finish of the mating components.	unitless	S_i	Variation in thickness between shaft washer raceway and back face (thrust bearing, flat back face)	mm, in
L_{10}	Predicted life, in revolutions, that 90 percent of a group of apparently identical bearings will complete or exceed before reaching a defined criterion	hours or 10^6 Rev.	T	Thickness of thrust bearing (thrust roller and cage assembly with washers)	mm, in
L_w	Overall roller length	mm, in	ν	Lubricant kinematic viscosity	cSt (mm ² /s)
L_{we}	Roller length applicable in the calculation of load ratings	mm, in	V_{Bs}	Variation of a single inner ring width $V_{Bs} = B_{s \max} - B_{s \min}$	mm, in
M	Minimum load (axial) constant for combined needle roller thrust ball bearing	mm, in	V_{Cs}	Variation of a single outer ring width $V_{Cs} = C_{s \max} - C_{s \min}$	mm, in
M	Bearing operating torque or moment	N-m, N-mm lb-in	V_{Dmp}	Variation of a mean outer diameter	mm, in
n	Speed, rotational	min ⁻¹	V_{dmp}	Variation of a mean bore diameter	mm, in
P	Equivalent dynamic radial load	kN, lbf	V_{dsp}	Variation of a single bore diameter in a single plane	mm, in
P_a	Equivalent dynamic axial load	kN, lbf	V_{Dsp}	Variation of a single outer diameter in a single plane	mm, in
P_o	Equivalent static radial load	kN, lbf	X	Dynamic radial load factor	unitless
P_{oa}	Equivalent static axial load	kN, lbf	Y	Dynamic axial radial load	unitless
P_{or}	Equivalent static radial load	kN, lbf	Z	Number of rollers per row	unitless
P_r	Equivalent dynamic radial load	kN, lbf			
R	Cam follower outer ring crown radius	mm, in			
r	Chamfer dimension, (radial and/or axial)	mm, in			
r_{1s}	Single chamfer dimension (radial)	mm, in			
$r_{1s \max}$	Largest permissible single chamfer dimension (radial)	mm, in			
$r_{1s \min}$	Smallest permissible single chamfer dimension (radial)	mm, in			
$r_{2s \max}$	Largest permissible single chamfer dimension (axial)	mm, in			
r_a	Chamfer dimension on a mating surface	mm, in			
R_a	Surface roughness parameter based on the arithmetic average departure of the surface from the theoretical centerline, formally AA or CLA	μm , μin			
r_{as}	Single chamfer dimension on a mating surface	mm, in			
R_q	Surface roughness parameter based on root mean square average departure of the surface from the theoretical centerline, formally RMS	μm , μin			
r_s	Single chamfer dimension (radial and/or axial)	mm, in			
$r_{s \min}$	Smallest permissible single chamfer dimension (radial and/or axial)	mm, in			
R_w	End radius rounded end roller	mm, in			
s	Nominal thrust washer thickness	mm, in			
S	Shaft raceway diameter	mm, in			

CODE	DESCRIPTION	PAGE	CODE	DESCRIPTION	PAGE
811, 812	Cylindrical roller thrust bearing with separable washers, this bearing consists of a thrust cylindrical roller and cage assembly, one shaft-piloted washer and one housing-piloted washer, metric series	B298-B301	CRS	Needle roller bearing, track rollers, stud type, full complement, with seals and internal thrust washers, cylindrical outer ring outer diameter, inch series	B256-B259
AR	Thrust cylindrical roller and cage assembly, with one unitized washer, metric series	B304-B307	CRSBCE	Needle roller bearing, track roller, stud type, full complement, with seals and internal thrust washers, hex socket, crowned outer ring outer diameter, eccentric stud, inch series	B250
ARZ	Thrust cylindrical roller and cage assembly, with two unitized washers, metric series	B302-B303	CRSB	Needle roller bearing, track roller, stud type, full complement, with seals and internal thrust washers, hex socket, inch series	B260-B263
AS	Thrust washer, stamped, for AXK series, metric series	B278-B281	CRSC	Needle roller bearing, track roller, stud type, full complement, with seals and internal thrust washers, crowned outer ring outside diameter, inch series	B250
AX	Thrust needle roller and cage assembly, with one unitized washer, metric series	B286-B293	DF	Drawn cup needle roller clutch with plastic housings, with axial grooves, metric series	B141
AXK	Thrust needle roller and cage assembly (without washers), one-piece M profile cage, metric series	B278-B281	DL	Drawn cup needle roller bearing, full complement, open ends, metric series	B76-B81
AXZ	Thrust needle roller and cage assembly, with two unitized washers, metric series	B302-B303	DLF	Drawn cup needle roller bearing, full complement, closed end, metric series	B76-B81
B	Drawn cup needle roller bearing, full complement, inch series	B92-B105	FC	Drawn cup needle roller clutch, regular series, multi-roller per stainless steel spring, metric series	B132-B133
BH	Drawn cup needle roller bearing, full complement, heavy series, inch series	B92-B105	FCB	Drawn cup needle roller clutch and bearing assembly, regular series, multi-roller per stainless steel spring, metric series	B134-B135
BIC	Inner ring for needle roller bearings, with lubrication hole, metric series	B382-B384	FCBL -K	Drawn cup needle roller clutch and bearing assembly, light series, single roller per stainless steel spring, metric series	B134-B135
BICG	Inner ring for needle roller bearings, extra wide, with lubrication hole, metric series	B382-B384	FCBN -K	Drawn cup needle roller clutch and bearing assembly, light series, single roller per stainless steel spring, metric series	B134-B135
BIG, BIK, BIP	Inner ring for needle roller bearings, extra wide, no lubrication hole, metric series	B382-B384	FCL -K	Drawn cup needle roller clutch, light series, single roller per stainless steel spring, metric series	B132-B133
BK	Drawn cup needle roller bearing, caged, closed end, metric series	B50-B59	FCL -K	Drawn cup needle roller clutch, light series, single roller per stainless steel spring, metric series	B132-B133
BK RS	Drawn cup needle roller bearing, closed end, caged with one seal, metric series	B60-B63	FCL -K	Drawn cup needle roller clutch, light series, single roller per stainless steel spring, metric series	B132-B133
CP	Thrust washer, for AX and AR series, metric series	B286-B293 & B304-B307	FCL -K	Drawn cup needle roller clutch, light series, single roller per stainless steel spring, metric series	B132-B133
CPN	Thrust washer, for AX series, precision, metric series	B286-B293	FCL -K	Drawn cup needle roller clutch, light series, single roller per stainless steel spring, metric series	B132-B133
CPR	Thrust washer, for AR series, heavy, metric series	B304-B307	FCL -K	Drawn cup needle roller clutch, light series, single roller per stainless steel spring, metric series	B132-B133
CR	Needle roller bearing, track rollers, stud type, full complement, cylindrical outer ring outer diameter, inch series	B256-B259	FCL -K	Drawn cup needle roller clutch, light series, single roller per stainless steel spring, metric series	B132-B133
			FCP	Drawn cup needle roller clutch, with axial grooves, metric series	B141
			FCS	Drawn cup needle roller clutch, regular series, single roller per stainless steel spring, metric series	B132-B133
			FG	Needle roller bearing, track roller, yoke type, full complement, crowned outer ring outside diameter, with inner ring, metric series	B243-B244



NEEDLE ROLLER BEARINGS



CODE	DESCRIPTION	PAGE	CODE	DESCRIPTION	PAGE
FGL	Needle roller bearing, track roller, yoke type, full complement, cylindrical outer ring outside diameter, with inner ring, metric series.....	B243-B244	GCRL	Needle roller bearing, track roller, stud type, full complement, cylindrical outer ring outside diameter, eccentric collar, metric series.....	B232-B233
FGU	Cylindrical roller bearing, track roller, yoke type, full complement, crowned outer ring outside diameter, with inner ring, metric series.....	B245-B247	GCU	Cylindrical roller bearing, track roller, stud type, full complement, crowned outer ring outside diameter, metric series.....	B230-B231
FGUL	Cylindrical roller bearing, track roller, yoke type, full complement, cylindrical outer ring outside diameter, with inner ring, metric series.....	B245-B247	GCUL	Cylindrical roller bearing, track roller, stud type, full complement, cylindrical outer ring outside diameter, metric series.....	B230-B231
FNT, FNTA	Thrust needle roller and cage assembly (without washers), two-piece cage, metric series.....	B278-B281	GCUR	Cylindrical roller bearings, track roller, stud type, full complement, crowned outer ring outside diameter, eccentric collar, metric series.....	B234-B235
FNTF	Thrust needle roller and cage assembly (with one washer), non-separable design with one I.D. lipped thrust washer, metric series....	B284-B285	GCURL	Cylindrical roller bearings, track roller, stud type, full complement, cylindrical outer ring outside diameter, eccentric collar, metric series.....	B234-B235
FNTK	Thrust needle roller and cage assembly (with one washer), non-separable design with one O.D. lipped thrust washer, metric series.....	B283	GS.811, GS.812	Thrust washer, housing piloted, metric series.....	B278-B281 & B298-B301
FNTKF	Thrust needle roller and cage assembly, with non-separable washers, one I.D. lipped washer and one O.D. lipped washer, metric series.....	B282	HJ	Needle roller bearing with integral flanges, lubricating groove and a lubricating hole in the outer ring, without inner ring, inch series.....	B194-B197
FP	Needle roller bearing, track roller, yoke type, full complement, crowned outer ring outside diameter, with inner ring, metric series.....	B242	HJ RS	Needle roller bearing with integral flanges, lubricating groove and a lubricating hole in the outer ring, without inner ring, with one seal, inch series.....	B198-B199
FPL	Needle roller bearing, track roller, yoke type, full complement, cylindrical outer ring outside diameter, inner ring, metric series.....	B242	HJ .2RS	Needle roller bearing with integral flanges, lubricating groove and a lubricating hole in the outer ring, with two seals, without inner ring, inch series.....	B198-B199
GB	Drawn cup needle roller bearing, full complement, extra-precision, inch series.....	B108	HK	Drawn cup needle roller bearing, open ends, caged, metric series.....	B50-B59
GBH	Drawn cup needle roller bearing, full complement, extra-precision, heavy series, inch series.....	B108	HK RS	Drawn cup needle roller bearing, open ends, caged with one seal, metric series.....	B60-B63
GC	Needle roller bearing, track roller, stud type, full complement, crowned outer ring outside diameter, metric series.....	B226-B229	HK .2RS	Drawn cup needle roller bearing, open ends, caged with two seals, metric series.....	B60-B63
GCL	Needle roller bearing, track roller, stud type, full complement, cylindrical outer ring outside diameter, metric series.....	B226-B229	IM	Inner ring for full complement drawn cup needle roller bearing, no lubrication hole, metric series.....	B82-B84 & B378-B381
GCR	Needle roller bearing, track roller, stud type, full complement, crowned outer ring outside diameter, eccentric collar, metric series.....	B232-B233	IMC	Inner ring for full complement drawn cup needle roller bearing, with lubrication hole, metric series.....	B82-B84 & B378-B380
			IM.R6	Inner ring for full complement drawn cup needle roller bearing, no lubrication hole, without raceway chamfer, metric series.....	B82-B84 & B378-B380

CODE	DESCRIPTION	PAGE	CODE	DESCRIPTION	PAGE
IR (≤4 digit)	Inner ring for drawn cup needle roller bearing, inch series	B120-B122	KR.2RS	Needle roller bearing, track roller, stud type, with cage, with seals, crowned outer ring outer diameter, metric series	B222-B223
IR (6 digit)	Inner ring for needle roller bearing, inch series	B194-B198 & B200-B203	KR.DZ	Needle roller bearing, track roller, stud type, with cage, cylindrical outer ring outer diameter, metric series.....	B220-B221
IRA	Inner ring for drawn cup needle roller bearing, extended width, inch series	B120-B122	KRV	Needle roller bearing, track roller, stud type, full complement, crowned outer ring outer diameter metric series	B224-B225
J	Drawn cup needle roller bearing, caged, inch series	B110-B117	KRV.DZ	Needle roller bearing, track roller, stud type, full complement, cylindrical outer ring outer diameter, metric series.....	B224-B225
JH	Drawn cup needle roller bearing, caged, heavy series, inch series.....	B110-B117	LS	Thrust washer for AXK series, heavy, metric series.....	B278-B281
JP-F	Drawn cup needle roller bearing, plastic finger cage, inch series	B110	M-1	Drawn cup needle roller bearing, full complement, closed end, inch series	B92-B105
JR	Inner ring for needle roller bearing, no lubrication hole, metric series.....	B65-B74 & B368-B377	MH-1	Drawn cup needle roller bearing, full complement, heavy series, closed end, inch series.....	B92-B105
JR.JS1	Inner ring for needle roller bearing, with lubrication hole, metric series.....	B65-B74 & B368-B377	MJ-1	Drawn cup needle roller bearing, caged, closed end, inch series	B110-B117
JRZ.JS1	Inner ring for needle roller bearing, with lubrication hole, without raceway chamfer, metric series.....	B65-B74 & B368-B377	MJH-1	Drawn cup needle roller bearing, caged, heavy series, closed end, inch series.....	B110-B117
JT	Drawn cup needle roller bearing with one seal, open ends, caged, inch series	B118-B119	NA1000	Needle roller bearing, full complement, with inner ring, metric series	B180-B182
JTT	Drawn cup needle roller bearing with two seals, open ends, caged, inch series	B118-B119	NA2000	Needle roller bearing, full complement, with inner ring, metric series	B180-B182
K	Radial needle roller and cage assembly, metric series.....	B8-B25	NA22000	Needle roller bearing, full complement, with inner ring, metric series	B180
K.BE	Radial needle roller and cage assembly for crank pin applications, metric series.....	B31-B32	NA22.2RS	Needle roller bearing, track roller, yoke type, with cage, with seals, with integral flanges, crowned outer ring outer diameter, with inner ring, metric series	B239
K.H	Radial needle roller and cage assembly, hardened steel cage, metric series	B8-B25	NA22.2RS.DZ	Needle roller bearing, track roller, yoke type, with cage, with seals, with integral flanges, cylindrical outer ring outer diameter, with inner ring, metric series	B239
K.SE	Radial needle roller and cage assembly for wrist pin applications, metric series.....	B33-B34	NA3000	Needle roller bearing, full complement, with inner ring, metric series	B180-B182
K.TN	Radial needle roller and cage assembly, molded cage of reinforced engineered polymer, metric series.....	B8-B25	NA48	Needle roller bearing, caged, with integral flanges, lubricating groove and one lubrication hole in the outer ring, with inner ring, metric series.....	B160
K.ZW	Radial needle roller and cage assembly, double-row, metric series.....	B8-B25	NA49	Needle roller bearing, caged, with integral flanges, lubricating groove and one lubricating hole in the outer ring, with inner ring, metric series.....	B155-B160
K.811, K.812	Thrust cylindrical roller and cage assembly (without washers), metric series.....	B298-B301			
KR	Needle roller bearing, track roller, stud type, with cage, crowned outer ring outer diameter, metric series.....	B220-B221			



NEEDLE ROLLER BEARINGS



CODE	DESCRIPTION	PAGE	CODE	DESCRIPTION	PAGE
NA49.RS	Needle roller bearing, caged, with integral flanges, lubricating groove and one lubricating hole in the outer ring, with inner ring, with one seal, metric series.....	B168	NKJ	Needle roller bearing, caged, with flanges (inserted or integral), with inner ring, metric series.....	B155-B160
NA49.2RS	Needle roller bearing, caged, with integral flanges, lubricating groove and one lubricating hole in the outer ring, with inner ring, with two seals, metric series.....	B168	NKJS	Needle roller bearing with integral flanges, lubricating groove and one lubricating hole in the outer ring, with inner ring, metric series.....	B155-B160
NA69	Needle roller bearing, caged, with flanges (inserted or integral), lubricating groove and one Lubricating hole in the outer ring, with inner ring (sizes with 32 mm and larger bores have two needle roller and cage assemblies), metric series.....	B155-B160	NKS	Needle roller bearing, caged, with integral flanges, lubricating groove and one lubricating hole in the outer ring, without inner ring, metric series.....	B161-B167
NAO	Needle roller bearing, caged, without flanges, with inner ring, metric series.....	B170-B172	NRO.B	Needle roller, flat end, metric series.....	B354
NATR	Needle roller bearing, track roller, yoke type, with cage, crowned outer ring outer diameter, with end washers, non-separable design with inner ring, metric series.....	B240	NTA	Thrust needle roller and cage assembly (without washers), two-piece cage, inch series.....	B312-B321
NATR.DZ	Needle roller bearing, track roller, yoke type, with cage, cylindrical outer ring outer diameter, with end washers, non-separable design with inner ring, metric series.....	B240	NTH	Thrust cylindrical roller and cage assembly (without washers), inch series.....	B322-B323
NAXK	Combined needle roller bearings, combination machined race needle roller and thrust ball bearing, with cage, single directional axial load capability, without inner ring, metric series.....	B332-B335	NTHA	Thrust cylindrical roller bearing with separable washers, one shaft-piloted washer and one housing-piloted washer, inch series.....	B324-B325
NAXK.Z	Combined needle roller bearings, combination machined race needle roller and thrust ball bearing, with cage, single directional axial load capability, with dust cap, without inner ring, metric series.....	B332-B335	NU	Cylindrical roller radial bearing, with two ribs on outer ring, cylindrical inner ring, metric series.....	B188-B190
NAXR	Combined needle roller bearings, combination machined race needle roller and thrust cylindrical roller bearing, with cage, single directional axial load capability, without inner ring, metric series.....	B336-B339	NUKR	Cylindrical roller bearing, track roller, stud-type, full complement, with shields, crowned outer ring outer diameter, metric series.....	B224-B225
NAXR.Z	Combined needle roller bearings, combination machined race needle roller and thrust cylindrical roller bearing, with cage, single directional axial load capability, with dust cap, without inner ring, metric series.....	B336-B339	NUKR.DZ	Cylindrical roller bearing, track roller, stud-type, full complement, with shields, cylindrical outer ring outer diameter, metric series.....	B224-B225
NJ	Cylindrical roller radial bearing, with two ribs on outer ring, one rib on inner ring, metric series.....	B188-B190	NUP	Cylindrical roller radial bearing, with two ribs on outer ring, one fixed rib and one loose rib/flat washer on inner ring, metric serie.....	B188-B190
NK	Needle roller bearing, caged, with flanges (inserted or integral), without inner ring, metric series.....	B161-B167	NUTR	Cylindrical roller bearing, track roller, yoke-type, full complement, crowned outer ring outer diameter, with end washers, non-separable design with inner ring, metric series.....	B241
			NUTR.DZ	Cylindrical roller bearing, track roller, yoke-type, full complement, cylindrical outer ring outer diameter, with end washers, non-separable design with inner ring, metric series.....	B241
			RAX400	Combined needle roller bearings, combination machined race needle roller and thrust needle roller bearing, with cage, single directional axial load capability, without inner ring, metric series.....	B340-B343

CODE	DESCRIPTION	PAGE	CODE	DESCRIPTION	PAGE
RAX 500	Combined needle roller bearings, combination machined race needle roller and thrust cylindrical roller bearing, with cage, single directional axial load capability, without inner ring, metric seriesB340-B343		RNA48	Needle roller bearing, caged, with integral flanges, lubricating groove and one lubricating hole in the outer ring, without inner ring, metric series B167	
RAX700	Combined needle roller bearings, combination drawn cup needle roller (with open ends) and thrust needle roller bearing, with cage, single directional axial load capability, without inner ring, metric seriesB344-B345		RNA49	Needle roller bearing, caged, with integral flanges, lubricating groove and one lubricating hole in the outer ring, without inner ring, metric series.....B161-B167	
RAXF700	Combined needle roller bearings, combination drawn cup needle roller (with closed end) and thrust needle roller bearing, with cage, single directional axial load capability, without inner ring, metric seriesB344-B345		RNA49RS	Needle roller bearing, caged, with integral flanges, lubricating groove and one lubricating hole in the outer ring, without inner ring, with one seal, metric series..... B169	
RAXZ500	Combined needle roller bearings, combination machined race needle roller and thrust cylindrical roller bearing, with cage, single directional axial load capability, without inner ring, with unitized thrust washer, metric series.....B336-B339		RNA49.2RS	Needle roller bearing, caged, with integral flanges, lubricating groove and one lubricating hole in the outer ring, without inner ring, with two seals, metric series..... B169	
RC	Drawn cup needle roller clutch, single roller per integral spring, inch seriesB136-B137		RNA69	Needle roller bearing, caged, with flanges (inserted or integral), lubricating groove and one lubricating hole in the outer ring, without inner ring (sizes with 40 mm and larger bores have two needle roller and cage assemblies), metric series.....B162-B167	
RC-FS	Drawn cup needle roller clutch, single roller per stainless steel spring, inch seriesB136-B137		RNAL11000	Needle roller bearing, track roller, yoke type, full complement, crowner outer ring outside diameter, without inner ring, metric series B248	
RCB	Drawn cup needle roller clutch and bearing assembly, single roller per integral spring, inch seriesB138-B139		RNAO	Needle roller bearing without flanges, without inner ring, metric series.....B173-B175	
RCB-FS	Drawn cup needle roller clutch and bearing assembly, single roller per stainless steel spring, inch seriesB138-B139		RSTO	Needle roller bearing, track roller, yoke type, with cage, crowned outer ring outer diameter, separable design without inner ring, metric series..... B236	
RNA1000	Needle roller bearing, full complement, without inner ring, metric series.....B176-B179		RSTO.DZ	Needle roller bearing, track roller, yoke type, with cage, cylindrical outer ring outer diameter, separable design without inner ring, metric series..... B236	
RNA11000, RNAB11000	Needle roller bearing, track roller, yoke type, full complement, crowned outer ring outside diameter, without inner ring, metric series..... B248		SNSH	End washers, for use with NAO and RNAO needle roller bearings, metric series..... B170-B175 & B385	
RNA2000	Needle roller bearing, full complement, without inner ring, metric series.....B176-B179		STO	Needle roller bearing, track roller, yoke type, with cage, crowned outer ring outer diameter, separable design with inner ring, metric series B237	
RNA22.2RS	Needle roller bearing, track roller, yoke type, with cage, with seals, with integral flanges, crowned outer ring outer diameter, without inner ring, metric series..... B238		STO.DZ	Needle roller bearing, track roller, yoke type, with cage, cylindrical outer ring outer diameter, separable design with inner ring, metric series B237	
RNA22.2RS.DZ	Needle roller bearing, track roller, yoke type, with cage, with seals, with integral flanges, cylindrical outer ring outer diameter, without inner ring, metric series..... B238				
RNA22000	Needle roller bearing, full complement, without inner ring, metric series.....B176-B177				
RNA3000	Needle roller bearing, full complement, without inner ring, metric series.....B176-B179				





CODE	DESCRIPTION	PAGE
STO.ZZ	Needle roller bearing, track roller, yoke type, with cage, crowned outer ring outer diameter, with end washers, separable design with inner ring, metric series.....	B240
STO.ZZ.DZ	Needle roller bearing, track roller, yoke type, with cage, cylindrical outer ring outer diameter, with end washers, separable design with inner ring, metric series	B240
TR	Thrust washer A, B, C, etc. indicates (A,B,C, etc) washer thickness, inch series	B312-B321
TRI	Thrust washer, shaft piloted, inch series	B324-B325
TRID	Thrust washer, housing piloted, inch series ...	B324-B325
TRJ	Thrust washer, shaft piloted, inch series	B324-B325
TRJD	Thrust washer, housing piloted, inch series	B324-B325
VEEN	Grease fitting for stud-type track rollers, metric series.....	B218
WJ	Radial needle roller and cage single-row assembly, heavy series, inch series.....	B37-B39
WJC	Radial needle roller and cage single-row, assembly, inch series	B37-B39
WS.811, WS.812	Thrust washer, shaft piloted, metric series.....	B278-B281 & B298-B301
YCR	Needle roller bearing, track roller, yoke type, full complement, cylindrical outer ring outer diameter, with end washers, non-separable design with inner ring, inch series	B264-B265
YCRS	Needle roller bearing, track roller, yoke type, full complement, with seals and internal thrust washers, cylindrical outer ring outer diameter, with end washers, non-separable design with inner ring, inch series	B264-B265
YCRSC	Needle roller bearing, track roller, yoke type, full complement, with seals and internal thrust washers, crowned outer ring outer diameter, with end washers, non-separable design with inner ring, inch series ...	B250
ZRO	Cylindrical roller, metric series	B365





NOTES



GLOBAL NETWORK

BEARING BUSINESS OPERATIONS

JTEKT CORPORATION NAGOYA HEAD OFFICE

No.7-1, Meieki 4-chome, Nakamura-ku, Nagoya, Aichi 450-8515,
JAPAN
TEL : 81-52-527-1900
FAX : 81-52-527-1911

JTEKT CORPORATION OSAKA HEAD OFFICE

No.5-8, Minamisemba 3-chome, Chuo-ku, Osaka 542-8502,
JAPAN
TEL : 81-6-6271-8451
FAX : 81-6-6245-3712

Sales & Marketing Headquarters

No.5-8, Minamisemba 3-chome, Chuo-ku, Osaka 542-8502,
JAPAN
TEL : 81-6-6245-6087
FAX : 81-6-6244-9007

OFFICES

KOYO CANADA INC.

5324 South Service Road, Burlington, Ontario L7L 5H5, CANADA
TEL : 1-905-681-1121
FAX : 1-905-681-1392

KOYO CORPORATION OF U.S.A.

-Cleveland Office-

29570 Clemens Road, P.O.Box 45028, Westlake,
OH 44145, U.S.A.
TEL : 1-440-835-1000
FAX : 1-440-835-9347

-Detroit Office-

47771 Halyard Drive, Plymouth, MI 48170, U.S.A.
TEL : 1-734-454-1500
FAX : 1-734-454-4076

KOYO BEARINGS USA LLC

-Canton Office-

4895 Dressler Road NW, Suite B, Canton, OH 44718, U.S.A.
TEL : 1-330-994-0900
FAX : 1-330-994-0960

KOYO MEXICANA, S.A. DE C.V.

Av. Insurgentes Sur 2376-505, Col. Chimalistac, Del. Álvaro
Obregón, C.P. 01070, México, D.F.
TEL : 52-55-5207-3860
FAX : 52-55-5207-3873

KOYO LATIN AMERICA, S.A.

Edificio Banco del Pacifico Planta Baja, Calle Aquilino de la
Guardia y Calle 52, Panama, REPUBLICA DE PANAMA
TEL : 507-208-5900
FAX : 507-264-2782/507-269-7578

KOYO ROLAMENTOS DO BRASIL LTDA.

Av. Reboucas 2472 Jardim America, Sao Paulo, BRASIL
TEL : 55-11-3372-7500
FAX : 55-11-3887-3039

KOYO BEARINGS INDIA PVT. LTD.

C/o Stylus Commercial Services PVT LTD, Ground Floor, The
Beech, E-1, Manyata Embassy Business Park, Outer Ring Road,
Bengaluru-560045, INDIA
TEL : 91-80-4276-4567 (Reception Desk of Service Office)
FAX : 91-80-4276-4568

JTEKT (THAILAND) CO., LTD.

172/1 Moo 12 Tambol Bangwua, Amphur Bangpakong,
Chachoengsao 24180, THAILAND
TEL : 66-38-830-571/578
FAX : 66-38-830-579

PT. JTEKT INDONESIA

d/a. MM2100 Industrial Town Block DD-3, Cikarang Barat, Bekasi
17520, INDONESIA
TEL : 62-21-8998-3273
FAX : 62-21-8998-3274

KOYO SINGAPORE BEARING (PTE.) LTD.

27, Penjuru Lane, #09-01 C&P Logistics Hub 2, SINGAPORE
609195
TEL : 65-6274-2200
FAX : 65-6862-1623

KOYO MIDDLE EAST FZCO

6EA 601, Dubai Airport Free Zone, P.O. Box 54816, Dubai,
U.A.E.
TEL : 97-1-4299-3600
FAX : 97-1-4299-3700

PHILIPPINE KOYO BEARING CORPORATION

6th Floor, One World Square Building, #10 Upper McKinley
Road, McKinley Town Center Fort Bonifacio, 1634 Taguig City,
PHILIPPINES
TEL : 63-2-856-5046/5047
FAX : 63-2-856-5045

JTEKT KOREA CO., LTD.

Inwoo Building 6F, 539-11, Shinsa-dong, Gangnam-Gu, Seoul,
KOREA
TEL : 82-2-549-7922
FAX : 82-2-549-7923

JTEKT (CHINA) CO., LTD.

Room.25A2, V-CAPITAL Building, 333 Xianxia Road, Changning
District, Shanghai 200336, CHINA
TEL : 86-21-5178-1000
FAX : 86-21-5178-1008

KOYO AUSTRALIA PTY. LTD.

Unit 2, 8 Hill Road, Homebush Bay, NSW 2127, AUSTRALIA
TEL : 61-2-8719-5300
FAX : 61-2-8719-5333

JTEKT EUROPE BEARINGS B.V.

Markerkant 13-01, 1314 AL Almere, THE NETHERLANDS
TEL : 31-36-5383333
FAX : 31-36-5347212

-KOYO BENELUX BRANCH OFFICE-

Energieweg 10a, 2964LE, Groot-Ammers, P.O. Box 1, 2965ZG
Nieuwpoort, THE NETHERLANDS
TEL : 31-184606800
FAX : 31-184606857

-KOYO ROMANIA REPRESENTATIVE OFFICE-

Str. Dr. Lister nr. 24, ap. 1, sector 5, cod 050543, Bucharest,
ROMANIA
TEL : 40-21-410-4170/4182/0984
FAX : 40-21-410-1178

-Sosnowiec Branch Office-

ul.3 Maja14, 41-200 Sosnowiec, POLAND
TEL : 48-32-720-1444
FAX : 48-32-746-7746

KOYO KULLAGER SCANDINAVIA A.B.

Johanneslundsvägen 4, 194 61 Upplands Väsby, SWEDEN
TEL : 46-8-594-212-10
FAX : 46-8-594-212-29

KOYO (U.K.) LIMITED

Whitehall Avenue, Kingston, Milton Keynes MK10 0AX,
UNITED KINGDOM
TEL : 44-1908-289300
FAX : 44-1908-289333

KOYO DEUTSCHLAND GMBH

Bargkoppelweg 4, D-22145 Hamburg, GERMANY
TEL : 49-40-67-9090-0
FAX : 49-40-67-9203-0

KOYO FRANCE S.A.

6 avenue du Marais, BP20189, 95105 Argenteuil, FRANCE
TEL : 33-1-3998-4202
FAX : 33-1-3998-4244/4249

KOYO BEARINGS VIERZON MAROMME SAS

-Colmar Office-

1 rue Denis Papin, CS20035, 68025 Colmar Cedex, FRANCE
TEL : 33-3-8977-9490
FAX : 33-3-8977-9548

KOYO IBERICA, S.L.

Avda.de la Industria, 52-2 izda 28820 Coslada Madrid, SPAIN
TEL : 34-91-329-0818
FAX : 34-91-747-1194

KOYO ITALIA S.R.L.

Via Stephenson 43/a 20157 Milano, ITALY
TEL : 39-02-2951-0844
FAX : 39-02-2951-0954

BEARING PLANTS

KOYO BEARINGS CANADA INC.

4 Victoria Street, Bedford, Quebec J0J-1A0, CANADA
TEL : 1-450-248-3316
FAX : 1-450-248-4196

KOYO CORPORATION OF U.S.A. (MANUFACTURING DIVISION)

-Orangeburg Plant-

2850 Magnolia Street, Orangeburg, SC 29115, U.S.A.
TEL : 1-803-536-6200
FAX : 1-803-534-0599

-Richland Plant-

1006 Northpoint Blvd., Blythewood, SC 29016, U.S.A.
TEL : 1-803-691-4624/4633
FAX : 1-803-691-4655

-Washington Plant-

146 Cutting Edge Court Telford, TN 37690, U.S.A.
TEL : 1-423-913-1006
FAX : 1-423-913-1008

KOYO BEARINGS USA LLC

-Dahlonega Plant-

615 Torrington Drive Dahlonega, GA 30533, U.S.A.
TEL : 1-706-864-7691
FAX : 1-706-864-8258

-Cairo Plant-

2525 Torrington Drive, PO BOX 2449, Cairo, GA 39828, U.S.A.
TEL : 1-229-377-6650
FAX : 1-229-377-9760

-Sylvania Plant-

400 Friendship Road, Sylvania, GA 30467, U.S.A.
TEL : 1-912-564-7151
FAX : 1-912-564-2101

-Walhalla Plant-

430 Torrington Road, Po Box 100, Walhalla, SC 29691, U.S.A.
TEL : 1-864-638-3683
FAX : 1-864-638-2434

JTEKT (THAILAND) CO., LTD.

172/1 Moo 12 Tambol Bangwua, Amphur Bangpakong,
Chachoengsao 24180, THAILAND
TEL : 66-38-830-571/578
FAX : 66-38-830-579

KOYO MANUFACTURING (PHILIPPINES) CORP.

Lima Technology Center, Municipality of Malvar, Batangas
Province 4233, PHILIPPINES
TEL : 63-43-981-0088
FAX : 63-43-981-0001

KOYO JICO KOREA CO., LTD.

28-12, Yulpo-Ri, Koduc-Myun, Pyung Teak-City, Kyungki-Do, KOREA
TEL : 82-31-668-6381
FAX : 82-31-668-6384

KOYO BEARING DALIAN CO., LTD.

No.11 A-2 Dalian Export Processing Zone, Dalian City, Liaoning,
CHINA
TEL : 86-411-8731-0972/0974
FAX : 86-411-8731-0973

WUXI KOYO BEARING CO., LTD.

No.89 Dicui Road, Liyuan Economic Development Zone, Wuxi,
Jiangsu, CHINA
TEL : 86-510-85161901
FAX : 86-510-85161143

KOYO NEEDLE BEARINGS (WUXI) CO., LTD.

No.85 Dicui Road, Liyuan Economic Development Zone, Wuxi,
Jiangsu, 214072 P.R. CHINA
TEL : 86-51085160998
FAX : 86-51085163262

DALIAN KOYO WAZHOU AUTOMOBILE BEARING CO., LTD.

No.96, Liaohe East Road, Dalian, D.D Port, CHINA
TEL : 86-411-8740-7272
FAX : 86-411-8740-7373

KOYO LIOHO (FOSHAN) AUTOMOTIVE PARTS CO., LTD.

No.12, Wusha Section Of Shunpan Road, Daliang Town, Shunde
Of Foshan, Guangdong Province, CHINA
(SHUNDE INDUSTRIAL PARK)
TEL : 86-757-22829589
FAX : 86-757-22829586

KOYO AUTOMOTIVE PARTS (WUXI) CO.,LTD.

B6-A Wuxi National Hi-Tech Industrial Development Zone, Wuxi,
Jiangsu, CHINA
TEL : 86-510-8533-0909
FAX : 86-510-8533-0155

KOYO BEARINGS (EUROPE) LTD.

P.O.Box 101, Elmhirst Lane, Dodworth, Barnsley,
South Yorkshire S75 3TA, UNITED KINGDOM
TEL : 44-1226-733200
FAX : 44-1226-204029

KOYO ROMANIA S.A.

Turnu Magurele Street No.1, 140003, ALEXANDRIA Teleorman
County, ROMANIA
TEL : 40-247-306-400
FAX : 40-247-306-421

KOYO BEARINGS DEUTSCHLAND GMBH

Werkstrasse 5, D-33790 Halle (Westfalen), GERMANY
TEL : 49-5201-7070
FAX : 49-5201-707416

KOYO BEARINGS VIERZON MAROMME SAS

-Maromme Plant-

Zone Industrielle de LA-BP 1033, 7 Rue Ampere, Maromme,
76151, FRANCE
TEL : 33-23282-3838
FAX : 33-23576-6624

-Vierzon Plant-

61 Route de Foecy-BP 238, Vierzon Cedex, 18102 FRANCE
TEL : 33-24852-6200
FAX : 33-24852-6250

KOYO BEARINGS MOULT SAS

Zone Industrielle de Moul, 14370, FRANCE
TEL : 33-23127-9600
FAX : 33-23123-4693

KOYO BEARINGS ČESKÁ REPUBLIKA S.R.O.

Pavelkova 253/5, Bystrovany, Olomouc, 77900, CZECH REP
TEL : 42-585-126-501
FAX : 42-585-126-503

KOYO BEARINGS ESPAÑA S.A.

Doctor Diaz Emparanza, 3, Bilbao, 48002, SPAIN
TEL : 34-94-4431400
FAX : 34-94-4440905

TECHNICAL CENTERS

JTEKT CORPORATION NORTH AMERICAN TECHNICAL CENTER

47771 Halyard Drive, Plymouth, MI 48170, U.S.A.
TEL : 1-734-454-1500
FAX : 1-734-454-4076

JTEKT RESEARCH AND DEVELOPMENT CENTER (WUXI) CO., LTD.

No.801 Hong Qiao Road, Li Yuan Economic Development Zone,
Wuxi Jiangsu 214072, CHINA
TEL : 86-510-8589-8613
FAX : 86-510-8589-8698

JTEKT CORPORATION EUROPEAN TECHNICAL CENTER

Markerkant 13-02, 1314 AL Almere, THE NETHERLANDS
TEL : 31-36-5383350
FAX : 31-36-5302656

KOYO BEARINGS USA LLC

GREENVILLE TECHNOLOGY CENTER

7 Research Drive, Greenville, SC 29607, U.S.A.
TEL : 1-864-770-2100
FAX : 1-864-770-2399

KOYO BEARINGS DEUTSCHLAND GMBH

KUENSEBECK TECHNOLOGY CENTER

Werkstrasse 5, D-33790 Halle (Westfalen), GERMANY
TEL : 49-5201-7070
FAX : 49-5201-707416

KOYO BEARINGS ČESKÁ REPUBLIKA S.R.O.

BRNO TECHNOLOGY CENTER

Technologický Park Brno, Technická 15, 61600 Brno, 61600
CZECH REP
TEL : 420-541-191803
FAX : 420-541-191801

Koyo[®]

Torrington[®] Needle Roller Bearings

Value & Technology



JTEKT

JTEKT CORPORATION

CAT. NO. B2016E-4
Printed in Japan '12.07-2CDS('10.01)
Torrington[®] is a registered
trademark of the Timken Company.