

NEEDLE ROLLER BEARINGS

C

C

C NEEDLE ROLLER BEARINGS

<i>Needle Roller Bearings and Cage Radial Assemblies.....</i>	C1
<i>Drawn Cup Needle Roller Bearings</i>	C35
<i>Heavy-Duty Needle Roller Bearings.....</i>	C95
<i>Stud Type and Yoke Type Track Rollers.....</i>	C155
<i>Needle Roller Thrust Bearings, Assemblies, Washers.....</i>	C223
<i>Combined Needle Roller Bearings</i>	C285
<i>Drawn Cup Roller Clutches</i>	C299
<i>Needle Roller Bearing Accessories.....</i>	C317



NEEDLE ROLLER BEARINGS



NEEDLE ROLLER AND CAGE RADIAL ASSEMBLIES

Overview: Needle roller and cage assemblies are a complement of needle rollers held in place by a cage. The mating shaft and housing are normally used as inner and outer raceways. The unitized design allows for easy handling and installation. Controlled-contour rollers reduce end stresses and permit operation under moderate misalignment. A variety of cage designs, styles and materials, as well as multiple roller paths and segmented constructions, meet broad application requirements.

- **Sizes:** 6 mm - 150 mm bore.
- **Markets:** Automotive and truck transmissions, agricultural and construction equipment, two-cycle engines, pumps and compressors.
- **Features:** Special coatings and platings; split and segmented designs for simplified mounting; engineered polymer cages.
- **Benefits:** High load capacity and high limiting speed within the smallest envelope.





C

Radial Needle Roller and Cage Assemblies – Metric Nominal Dimensions

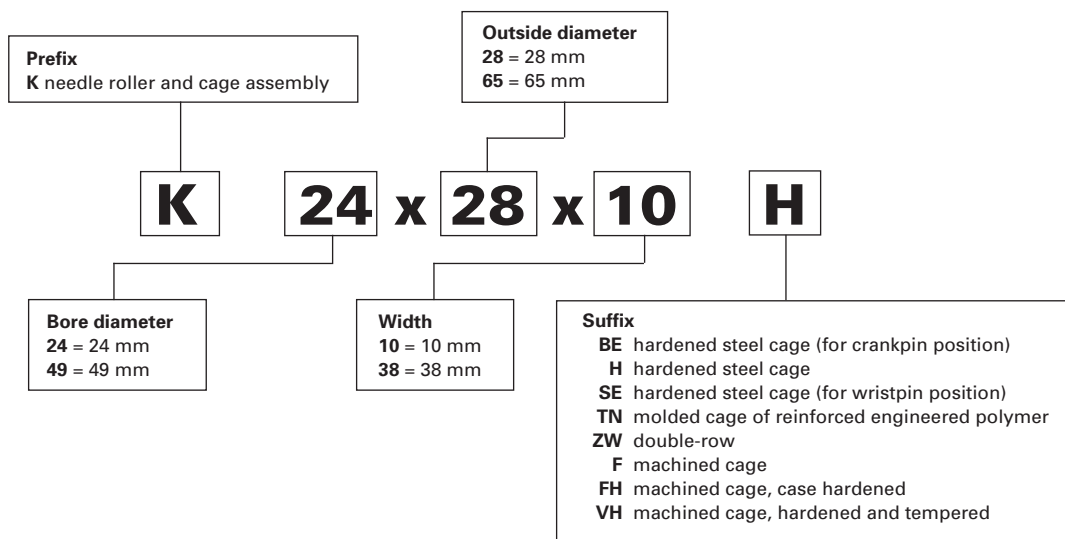

Radial Needle Roller and Cage Assemblies – Inch Nominal Dimensions

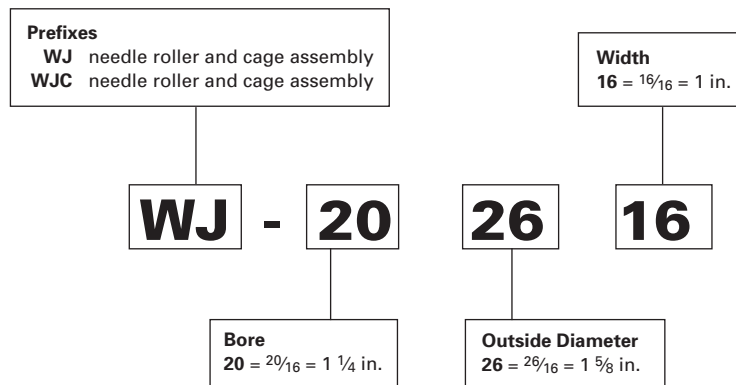

Needle Roller Bearings and Cage Radial Assemblies

	<i>Page</i>
Introduction	C4
Single-Row, Double-Row Assemblies Metric Series	C6
Needle Roller and Cage Radial Assemblies Inch Series.	C31
Single-Row Assemblies Inch Series	C33
Introduction of Needle Roller and Cage Radial Assemblies For Connecting Rod Applications	C22
Connecting Rod Guidance Arrangements	C24
Connecting Rod Applications.....	C26
Assemblies for Crank Pin End Applications	C27
Assemblies for Wrist Pin End Applications.....	C29





NEEDLE ROLLER AND CAGE RADIAL ASSEMBLIES

METRIC SERIES

Timken® Torrington® metric series needle roller and cage radial assemblies are available in a variety of sizes and designs. This catalog includes the most popular, standardized and non-standard designs.

REFERENCE STANDARDS ARE:

- **ISO 3030** – Needle roller bearings – Needle roller and cage radial assemblies – Boundary dimensions and tolerances
- **DIN 5405 Part 1** – Rolling bearings – needle bearings – Radial needle roller and cage assemblies.
- **ANSI/ABMA 18.1** – Needle roller bearings – Radial, metric design.

Before selecting specific metric series needle roller and cage radial assemblies, the engineering section of this catalog should be reviewed.

Types of Metric Series Needle Roller and Cage Radial Assemblies

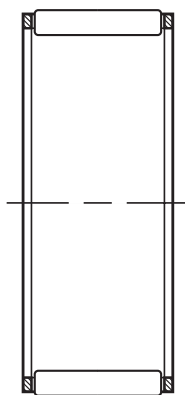

K ...

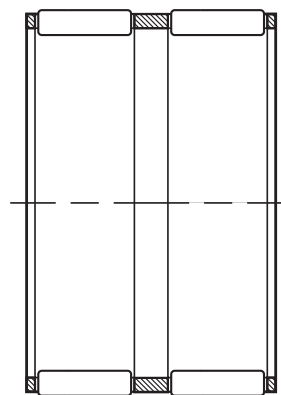

K ... ZW

Suffixes

TN	molded cage of reinforced engineered polymer
ZW	double - row
TNZW	molded cage of reinforced engineered polymer – double - row
H	hardened steel cage
F	machined cage
FH	machined cage, case hardened
FV	machined cage, hardened and tempered

CONSTRUCTION

Needle roller and cage radial assemblies have a steel cage that provides both inward and outward retention for the needle rollers. The designs provide maximum cage strength consistent with the inherent high load ratings of needle roller bearings. Accurate guidance of the needle rollers by the cage bars allows for operation at high speeds. Needle roller and cage assemblies have either one or two rows of needle rollers.

Also listed are metric series needle roller and cage assemblies using molded, one piece glass reinforced engineered polymer cages (suffix TN). These operate well at temperatures up to

120° C over extended periods. However, care should be exercised when these assemblies are lubricated with oils containing additives as service life may be reduced if the operating temperature exceeds 100° C. At such high temperatures oil can deteriorate with time and it is suggested that oil change intervals are observed.

Needle rollers with relieved ends used in these assemblies are made of high carbon chrome steel, through-hardened, ground and lapped to close tolerances for diameter and roundness. See the engineering section of this catalog for further discussion of relieved end rollers.

DIMENSIONAL ACCURACY

NEEDLE ROLLER GROUPS (GAGES)

Metric series needle roller and cage radial assemblies are supplied with needle roller complements subdivided into groups (gages) shown in Table 1. The groups are at Timken's option if nothing to the contrary is agreed upon at the time of ordering. This is in accordance with Grade G2 specified in ISO 3096 standard (see needle rollers, page C326). The group limits of the needle rollers are indicated on the package. Labels of identifying colors show the group limits of the needle rollers. The needle roller and cage assemblies of one shipment usually contain needle rollers with group limits of between 0 to -2, and -5 to -7 mm (colors red, blue and white). Information on needle roller and cage assemblies with needle rollers of different group limits will be supplied on request.

TABLE 1 – NEEDLE ROLLER GROUP LIMITS (GRADE G2)

Group	Tolerance µm	Marking	Identifying color of label or on package
0	-2	P0M2	
-1	-3	M1M3	red
-2	-4	M2M4	
-3	-5	M3M5	blue
-4	-6	M4M6	
-5	-7	M5M7	white (gray)
-6	-8	M6M8	
-7	-9	M7M9	green
-8	-10	M8M10	
-9	-11	M9M11	yellow

In the marking of the gages, P identifies zero (0) or plus (+), M identifies minus (-).

MOUNTING DIMENSIONS

DESIGN OF RACEWAYS

Needle roller and cage radial assemblies use the housing bore as the outer raceway and the shaft as the inner raceway. In order to realize full bearing load rating and life the housing bore and the shaft raceways must have the correct geometric and metallurgical characteristics. The housing should be of sufficient cross section to maintain adequate roundness and running clearance under load. Additional design details for housings and shafts used as outer and inner raceway can be found in the engineering section of this catalog. The only limit to precision of the radial clearance of a mounted assembly is the capability of the user to hold close tolerances on the inner and outer raceways. The suggested shaft tolerances listed in Table 2 are based on housing bore tolerance G6 and apply to metric series radial needle roller and cage assemblies with needle rollers of group limits between P0M2 and M5M7.

TABLE 2 – SUGGESTED SHAFT TOLERANCES FOR HOUSING BORES MACHINED TO G6

Nominal shaft diameter in mm	SHAFT TOLERANCE	
	≤ 80	> 80
RADIAL CLEARANCE	SHAFT TOLERANCE	
smaller than normal	j5	h5
normal	h5	g5
larger than normal	g6	f6

AXIAL GUIDANCE REQUIREMENTS

Needle roller and cage radial assembly must be axially guided by shoulders or other suitable means. The end guiding surfaces should be hardened to minimize wear and must provide sufficient axial clearance to prevent end locking of the assembly. Length tolerance H11 is suggested.

If end guidance is provided by a housing shoulder at one end and by a shaft shoulder at the other end the shaft must be axially positioned to prevent end locking of needle roller and cage assembly. The housing and shaft shoulder heights should be 70 to 90 percent of the needle roller diameter to provide proper axial guidance.

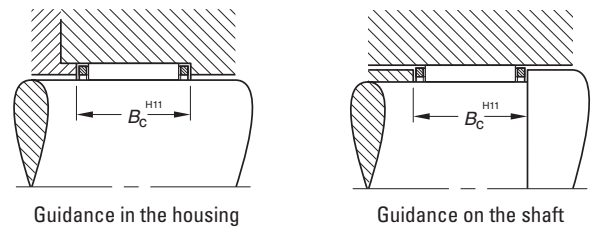

MOUNTING IN SETS

Needle roller and cage radial assemblies that are mounted side by side must have needle rollers of the same group limits to ensure uniform load distribution.

LUBRICATION

Oil is the preferred lubricant for most applications. In critical applications involving high speeds, ample oil flow must be provided. Where assemblies are subjected to high centrifugal forces, such as in epicyclic gearing, or inertia forces as in the small end of a connecting rod, the contact pressure between the cage and the raceway guiding surface becomes critical. The allowable contact pressure depends on a combination of the induced force and the rubbing velocity between the cage and raceway and the rate of lubricant flow. Consult your Timken representative when cages will be subjected to high induced forces.

SPECIAL DESIGNS

Needle roller and cage radial assemblies made to special dimensions or configurations, such as those which are split to assemble around a one piece crankshaft, can be made available on special order. Special coated or plated cages to enhance life under conditions of marginal lubrication and high induced forces can also be made available.



NEEDLE ROLLER BEARINGS

SINGLE-ROW, DOUBLE-ROW ASSEMBLIES

METRIC SERIES

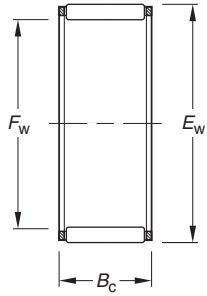

K

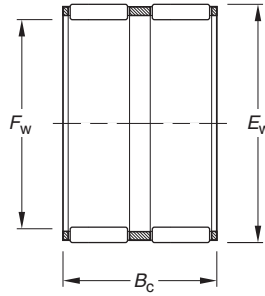

K.ZW

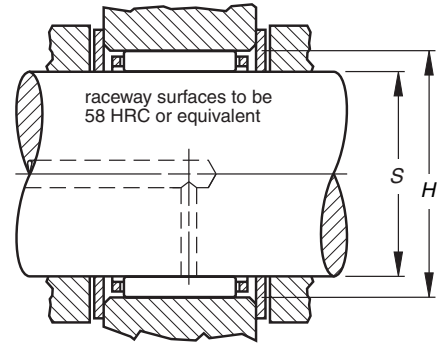

Shaft Dia.	Dimensions mm/in.			Assembly Designation	Load Ratings		Limiting Speed		C ₉	Mounting Dimensions mm/in.				Wt. kg/lbs.
	F _w	E _w	B _c		C	C ₀	Grease	Oil		Max.	Min.	Min.	Max.	
mm	mm	mm	mm				RPM			S	H			
4	4	7	7.0	K4X7X7TN	1.83	1.32	34000	52000	—	4.000	3.995	7.005	7.014	0.00
	0.1575	0.2756	0.276		411	297								
5	5	8	8.0	K5X8X8TN	2.18	1.71	31000	47000	—	5.000	4.995	8.005	8.014	0.001
	0.1969	0.3150	0.315		490	384				0.1969	0.1967	0.3152	0.3155	0.002
	5	8	10.0	K5X8X10TN	3.04	2.63	31000	47000	—	5.000	4.995	8.005	8.014	0.001
5	0.1969	0.3150	0.394		683	591				0.1969	0.1967	0.3152	0.3155	0.002
	5	9	13.0	K5X9X13TN	4.29	3.55	26000	40000	—	5.000	4.995	9.005	9.014	0.002
	0.1969	0.3543	0.512		964	798				0.1969	0.1967	0.3545	0.3549	0.004
6	6	9	8.0	K6X9X8	3.19	2.90	29000	44000	0.0116	6.000	5.995	9.005	9.014	0.001
	0.2362	0.3543	0.315		717	652				0.2362	0.2360	0.3545	0.3549	0.002
	6	9	8.0	K6X9X8TN	2.47	2.07	29000	44000	—	6.000	5.995	9.005	9.014	0.001
6	0.2362	0.3543	0.315		555	465				0.2362	0.2360	0.3545	0.3549	0.002
	6	9	10.0	K6X9X10TN	3.07	2.74	29000	44000	—	6.000	5.995	9.005	9.014	0.001
	0.2362	0.3543	0.394		690	616				0.2362	0.2360	0.3545	0.3549	0.002
7	7	10	8.0	K7X10X8TN	2.74	2.44	28000	42000	—	7.000	6.994	10.005	10.014	0.001
	0.2756	0.3937	0.315		616	549				0.2756	0.2754	0.3939	0.3943	0.002
	7	10	10.0	K7X10X10TN	3.40	3.22	28000	42000	—	7.000	6.994	10.005	10.014	0.001
7	0.2756	0.3937	0.394		764	724				0.2756	0.2754	0.3939	0.3943	0.002
	7	11	15.0	K7X11X15TN	6.44	6.24	23000	35000	—	7.000	6.994	11.006	11.017	0.000
	0.2756	0.4331	0.591		1450	1400				0.2756	0.2754	0.4333	0.4337	0.000
8	8	11	8.0	K8X11X8FV	3.23	3.11	26000	41000	0.0132	8.000	7.994	11.006	11.017	0.002
	0.3150	0.4331	0.315		726	699				0.3150	0.3147	0.4333	0.4337	0.004
	8	11	8.0	K8X11X8TN	2.34	2.05	26000	41000	—	8.000	7.994	11.006	11.017	0.002
8	0.3150	0.4331	0.315		526	461				0.3150	0.3147	0.4333	0.4337	0.003
	8	11	10.0	K8X11X10	4.57	4.89	26000	41000	0.0148	8.000	7.994	11.006	11.017	0.002
	0.3150	0.4331	0.394		1030	1100				0.3150	0.3147	0.4333	0.4337	0.004
8	8	11	10.0	K8X11X10FV	4.01	4.11	26000	41000	0.0142	8.000	7.994	11.006	11.017	0.002
	0.3150	0.4331	0.394		901	924				0.3150	0.3147	0.4333	0.4337	0.004
	8	11	13.0	K8X11X13H	5.22	5.78	26000	41000	0.0154	8.000	7.994	11.006	11.017	0.003
8	0.3150	0.4331	0.512		1170	1300				0.3150	0.3147	0.4333	0.4337	0.007
	8	12	10.0	K8X12X10F	5.05	4.69	22000	33000	0.0143	8.000	7.994	12.006	12.017	0.002
	0.3150	0.4724	0.394		1140	1050				0.3150	0.3147	0.4727	0.4731	0.004
9	9	12	10.0	K9X12X10FH	4.27	4.60	26000	40000	0.0153	9.000	8.994	12.006	12.017	0.003
	0.3543	0.4724	0.394		960	1030				0.3543	0.3541	0.4727	0.4731	0.007
	9	12	10.0	K9X12X10FV	4.27	4.60	26000	40000	0.0153	9.000	8.994	12.006	12.017	0.002
9	0.3543	0.4724	0.394		960	1030				0.3543	0.3541	0.4727	0.4731	0.004
	9	12	13.0	K9X12X13F	5.57	6.47	26000	40000	0.0167	9.000	8.994	12.006	12.017	0.003
	0.3543	0.4724	0.512		1250	1450				0.3543	0.3541	0.4727	0.4731	0.007
9	9	12	13.0	K9X12X13FH	5.57	6.47	26000	40000	0.0167	9.000	8.994	12.006	12.017	0.003
	0.3543	0.4724	0.512		1250	1450				0.3543	0.3541	0.4727	0.4731	0.007
	9	12	13.0	K9X12X13FV	5.57	6.47	26000	40000	0.0167	9.000	8.994	12.006	12.017	0.003
9	0.3543	0.4724	0.512		1250	1450				0.3543	0.3541	0.4727	0.4731	0.007
	9	13	8.0	K9X13X8H	3.96	3.50	21000	32000	0.0139	9.000	8.994	13.006	13.017	0.003
	0.3543	0.5118	0.315		890	787				0.3543	0.3541	0.5120	0.5125	0.007
10	10	13	10.0	K10X13X10	5.40	6.43	25000	39000	0.0174	10.000	9.994	13.006	13.017	0.002
	0.3937	0.5118	0.394		1210	1450				0.3937	0.3935	0.5120	0.5125	0.004

Shaft Dia.	Dimensions mm/in. -0.2 - .008 -0.55 - .022			Assembly Designation	Load Ratings kN/lbf.		Limiting Speed		C _q	Mounting Dimensions mm/in.				Wt. kg/lbs.
	F _w	E _w	B _c		C	C ₀	Grease	Oil		Max.	Min.	Min.	Max.	
mm							RPM			S	H			
10	10	13	10.0	K10X13X10H	5.40	6.43	25000	39000	0.0174	10.000	9.994	13.006	13.017	0.002
	0.3937	0.5118	0.394		1210	1450				0.3937	0.3935	0.5120	0.5125	
10	10	13	10.0	K10X13X10TN	4.29	4.77	25000	39000	—	10.000	9.994	13.006	13.017	0.002
	0.3937	0.5118	0.394		964	1070				0.3937	0.3935	0.5120	0.5125	
10	10	13	13.0	K10X13X13	5.90	7.16	25000	39000	0.0178	10.000	9.994	13.006	13.017	0.003
	0.3937	0.5118	0.512		1330	1610				0.3937	0.3935	0.5120	0.5125	
10	10	13	16.0	K10X13X16	7.43	9.64	25000	39000	0.0192	10.000	9.994	13.006	13.017	0.004
	0.3937	0.5118	0.630		1670	2170				0.3937	0.3935	0.5120	0.5125	
10	10	14	10.0	K10X14X10H	6.12	6.29	20000	31000	0.0167	10.000	9.994	14.006	14.017	0.003
	0.3937	0.5512	0.394		1380	1410				0.3937	0.3935	0.5514	0.5519	
10	10	14	13.0	K10X14X13H	7.88	8.71	20000	31000	0.0181	10.000	9.994	14.006	14.017	0.004
	0.3937	0.5512	0.512		1770	1960				0.3937	0.3935	0.5514	0.5519	
10	10	16	12.0	K10X16X12F	8.39	7.47	15000	24000	0.0168	10.000	9.994	16.006	16.017	0.006
	0.3937	0.6299	0.472		1890	1680				0.3937	0.3935	0.6302	0.6306	
10	10	16	12.0	K10X16X12TN	7.50	6.40	15000	24000	—	10.000	9.994	16.006	16.017	0.005
	0.3937	0.6299	0.472		1690	1440				0.3937	0.3935	0.6302	0.6306	
12	12	15	10.0	K12X15X10H	5.85	7.51	24000	37000	0.0195	12.000	11.992	15.006	15.017	0.003
	0.4724	0.5906	0.394		1320	1690				0.4724	0.4721	0.5908	0.5912	
12	12	15	13.0	K12X15X13H	6.78	9.03	24000	37000	0.0204	12.000	11.992	15.006	15.017	0.004
	0.4724	0.5906	0.512		1520	2030				0.4724	0.4721	0.5908	0.5912	
12	12	16	13.0	K12X16X13	7.49	8.51	19000	30000	0.0194	12.000	11.992	16.006	16.017	0.000
	0.4724	0.6299	0.512		1680	1910				0.4724	0.4721	0.6302	0.6306	
12	12	17	13.0	K12X17X13	8.93	9.29	16000	25000	0.0194	12.000	11.992	17.006	17.017	0.008
	0.4724	0.6693	0.512		2010	2090				0.4724	0.4721	0.6695	0.6700	
12	12	18	12.0	K12X18X12H	9.76	9.40	14000	22000	0.0191	12.000	11.992	18.006	18.017	0.009
	0.4724	0.7087	0.472		2190	2110				0.4724	0.4721	0.7089	0.7093	
13	13	17	10.0	K13X17X10	7.22	8.33	19000	29000	0.0199	13.000	12.992	17.006	17.017	0.004
	0.5118	0.6693	0.394		1620	1870				0.5118	0.5115	0.6695	0.6700	
13	13	18	15.0	K13X18X15F	10.8	12.1	16000	25000	0.0213	13.000	12.992	18.006	18.017	0.008
	0.5118	0.7087	0.591		2430	2720				0.5118	0.5115	0.7089	0.7093	
14	14	18	8.0	K14X18X8	5.39	5.82	19000	29000	0.0188	14.000	13.992	18.006	18.017	0.004
	0.5512	0.7087	0.315		1210	1310				0.5512	0.5509	0.7089	0.7093	
14	14	18	10.0	K14X18X10	7.17	8.41	19000	29000	0.0206	14.000	13.992	18.006	18.017	0.005
	0.5512	0.7087	0.394		1 610	1890				0.5512	0.5509	0.7089	0.7093	
14	14	18	13.0	K14X18X13	9.73	12.5	19000	29000	0.0227	14.000	13.992	18.006	18.017	0.006
	0.5512	0.7087	0.512		2190	2810				0.5512	0.5509	0.7089	0.7093	
14	14	18	15.0	K14X18X15	10.5	13.8	19000	29000	0.0233	14.000	13.992	18.006	18.017	0.007
	0.5512	0.7087	0.591		2360	3100				0.5512	0.5509	0.7089	0.7093	
14	14	18	17.0	K14X18X17H	12.4	17.1	19000	29000	0.0246	14.000	13.992	18.006	18.017	0.008
	0.5512	0.7087	0.669		2790	3840				0.5512	0.5509	0.7089	0.7093	
14	14	19	13.0	K14X19X13H	10.2	11.4	16000	24000	0.0217	14.000	13.992	19.007	19.020	0.008
	0.5512	0.7480	0.512		2290	2560				0.5512	0.5509	0.7483	0.7488	
14	14	19	18.0	K14X19X18F	13.2	16.0	16000	24000	0.0236	14.000	13.992	19.007	19.020	0.011
	0.5512	0.7480	0.709		2970	3600				0.5512	0.5509	0.7483	0.7488	
14	14	20	12.0	K14X20X12	10.5	10.6	14000	21000	0.0209	14.000	13.992	20.007	20.020	0.009
	0.5512	0.7874	0.472		2360	2380				0.5512	0.5509	0.7877	0.7882	
15	15	18	14.0	K15X18X14TN	7.92	11.9	13000	23000	—	15.000	14.992	18.006	18.017	0.003
	0.5906	0.7087	0.551		1780	2680				0.5906	0.5902	0.7089	0.7093	
15	15	18	16.0	K15X18X16F	8.36	12.6	13000	23000	0.0244	15.000	14.992	18.006	18.017	0.005
	0.5906	0.7087	0.630		1880	2830				0.5906	0.5902	0.7089	0.7093	
15	15	18	17.0	K15X18X17	8.08	12.1	23000	36000	0.0241	15.000	14.992	18.006	18.017	0.005
	0.5906	0.7087	0.669		1820	2720				0.5906	0.5902	0.7089	0.7093	
15	15	19	10.0	K15X19X10	7.87	9.69	18000	28000	0.0220	15.000	14.992	19.007	19.020	0.005
	0.5906	0.7480	0.394		1770	2180				0.5906	0.5902	0.7483	0.7488	
15	15	19	13.0	K15X19X13	9.66	12.6	18000	28000	0.0235	15.000	14.992	19.007	19.020	0.007
	0.5906	0.7480	0.512		2170	2830				0.5906	0.5902	0.7483	0.7488	
15	15	19	17.0	K15X19X17	12.3	17.2	18000	28000	0.0254	15.000	14.992	19.007	19.020	0.009
	0.5906	0.7480	0.669		2770	3870				0.5906	0.5902	0.7483	0.7488	

Continued on next page.



NEEDLE ROLLER BEARINGS

SINGLE-ROW, DOUBLE-ROW ASSEMBLIES — continued

METRIC SERIES

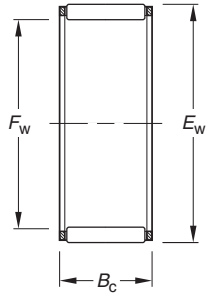

K

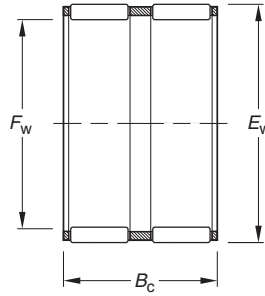

K.ZW

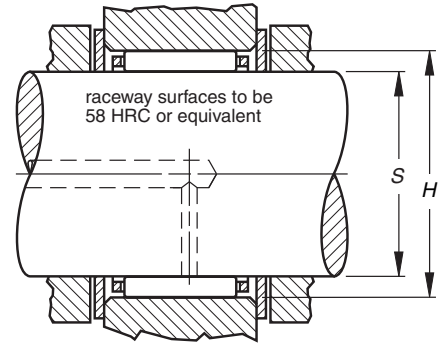

Shaft Dia.	Dimensions mm/in.			Assembly Designation	Load Ratings		Limiting Speed		Mounting Dimensions mm/in.	Wt. kg/lbs.				
	F _w	E _w	B _c		C	C ₀	Grease	Oil			Max.	Min.	Min.	Max.
mm	F _w	E _w	B _c		C	C ₀	RPM		C _q	S		H		
	15	19	17.0	K15X19X17H	12.3	17.2	18000	28000	0.0254	15.000	14.992	19.007	19.020	0.009
	0.5906	0.7480	0.669		2770	3870	0.5906	0.5902		0.7483	0.7488	0.020		
	15	19	22.0	K15X19X22ZW	12.2	17.0	18000	28000	0.0253	15.000	14.992	19.007	19.020	0.010
	0.5906	0.7480	0.866		2740	3820	0.5906	0.5902		0.7483	0.7488	0.022		
	15	20	13.0	K15X20X13H	9.93	11.3	16000	24000	0.0222	15.000	14.992	20.007	20.020	0.008
	0.5906	0.7874	0.512		2230	2540	0.5906	0.5902		0.7877	0.7882	0.018		
	15	21	15.0	K15X21X15	13.4	14.8	14000	21000	0.0233	15.000	14.992	21.007	21.020	0.013
	0.5906	0.8268	0.591		3010	3330	0.5906	0.5902		0.8270	0.8276	0.029		
	15	21	21.0	K15X21X21H	18.0	21.7	14000	21000	0.0256	15.000	14.992	21.007	21.020	0.018
	0.5906	0.8268	0.827		4050	4880	0.5906	0.5902		0.8270	0.8276	0.040		
16	16	20	8.0	K16X20X8F	6.37	7.51	18000	28000	0.0212	16.000	15.992	20.007	20.020	0.005
	0.6299	0.7874	0.315		1430	1690	0.6299	0.6296		0.7877	0.7882	0.011		
	16	20	10.0	K16X20X10	7.82	9.76	18000	28000	0.0226	16.000	15.992	20.007	20.020	0.006
	0.6299	0.7874	0.394		1760	2190	0.6299	0.6296		0.7877	0.7882	0.013		
	16	20	10.0	K16X20X10H	7.82	9.76	18000	28000	0.0226	16.000	15.992	20.007	20.020	0.006
	0.6299	0.7874	0.394		1760	2190	0.6299	0.6296		0.7877	0.7882	0.013		
	16	20	10.6	K16X20X10,6TN1	6.06	7.01	18000	28000	—	16.000	15.992	20.007	20.020	0.003
	0.6299	0.7874	0.417		1360	1580	0.6299	0.6296		0.7877	0.7882	0.007		
	16	20	13.0	K16X20X13	10.1	13.5	18000	28000	0.0245	16.000	15.992	20.007	20.020	0.007
	0.6299	0.7874	0.512		2270	3030	0.6299	0.6296		0.7877	0.7882	0.015		
	16	20	14.0	K16X20X14	10.8	14.8	18000	28000	0.0251	16.000	15.992	20.007	20.020	0.007
	0.6299	0.7874	0.551		2430	3330	0.6299	0.6296		0.7877	0.7882	0.015		
	16	20	17.0	K16X20X17F	11.9	16.8	18000	28000	0.0259	16.000	15.992	20.007	20.020	0.009
	0.6299	0.7874	0.669		2680	3780	0.6299	0.6296		0.7877	0.7882	0.020		
	16	20	17.0	K16X20X17H	12.9	18.5	18000	28000	0.0265	16.000	15.992	20.007	20.020	0.008
	0.6299	0.7874	0.669		2900	4160	0.6299	0.6296		0.7877	0.7882	0.018		
	16	20	20.0	K16X20X20	13.4	19.5	18000	28000	0.0269	16.000	15.992	20.007	20.020	0.011
	0.6299	0.7874	0.787		3010	4380	0.6299	0.6296		0.7877	0.7882	0.024		
	16	21	10.0	K16X21X10HD	7.69	8.22	18000	28000	0.0211	16.000	15.992	21.007	21.020	0.007
	0.6299	0.8268	0.394		1730	1850	0.6299	0.6296		0.8270	0.8276	0.015		
	16	22	12.0	K16X22X12	11.2	11.9	19000	29000	0.0227	16.000	15.992	22.007	22.020	0.010
	0.6299	0.8661	0.472		2520	2680	0.6299	0.6296		0.8664	0.8669	0.022		
	16	22	16.0	K16X22X16	14.9	17.2	19000	29000	0.0248	16.000	15.992	22.007	22.020	0.014
	0.6299	0.8661	0.630		3350	3870	0.6299	0.6296		0.8664	0.8669	0.031		
	16	22	16.0	K16X22X16H.ZB2	14.9	17.2	19000	29000	0.0248	16.000	15.992	22.007	22.020	0.014
	0.6299	0.8661	0.630		3350	3870	0.6299	0.6296		0.8664	0.8669	0.031		
	16	22	20.0	K16X22X20	18.6	22.9	19000	29000	0.0267	16.000	15.992	22.007	22.020	0.017
	0.6299	0.8661	0.787		4180	5150	0.6299	0.6296		0.8664	0.8669	0.037		
	16	24	20.0	K16X24X20	20.2	21.4	20000	30000	0.0255	16.000	15.992	24.007	24.020	0.025
	0.6299	0.9449	0.787		4540	4810	0.6299	0.6296		0.9452	0.9457	0.055		
17	17	20	10.0	K17X20X10	5.96	8.53	16000	25000	0.0234	17.000	16.992	20.007	20.020	0.004
	0.6693	0.7874	0.394		1340	1920	0.6693	0.6690		0.7877	0.7882	0.009		
	17	21	10.0	K17X21X10	8.12	10.4	17000	26000	0.0236	17.000	16.992	21.007	21.020	0.006
	0.6693	0.8268	0.394		1830	2340	0.6693	0.6690		0.8270	0.8276	0.013		
	17	21	12.8	K17X21X13H	10.5	14.5	17000	26000	0.0256	17.000	16.992	21.007	21.020	0.008
	0.6693	0.8268	0.504		2360	3260	0.6693	0.6690		0.8270	0.8276	0.018		

Shaft Dia.	Dimensions mm/in.			Assembly Designation	Load Ratings		Limiting Speed		C _q	Mounting Dimensions mm/in.				Wt. kg/lbs.
	-0.2 - .008 -0.55 - .022				kN/lbf.		Grease	Oil		Max.	Min.	Min.	Max.	
	mm	F _w	E _w		B _c	C	C ₀	RPM		S	H			
	17	21	13.0	K17X21X13	10.5	14.5	17000	26000	0.0256	17.000	16.992	21.007	21.020	0.008
	0.6693	0.8268	0.512		2360	3260				0.6693	0.6690	0.8270	0.8276	
	17	21	15.0	K17X21X15	11.4	16.1	17000	26000	0.0263	17.000	16.992	21.007	21.020	0.008
	0.6693	0.8268	0.591		2560	3620				0.6693	0.6690	0.8270	0.8276	
	17	21	17.0	K17X21X17H	13.4	19.8	17000	26000	0.0277	17.000	16.992	21.007	21.020	0.011
	0.6693	0.8268	0.669		3010	4450				0.6693	0.6690	0.8270	0.8276	
	17	22	20.0	K17X22X20FH	17.0	23.3	17000	27000	0.0280	17.000	16.992	22.007	22.020	0.015
	0.6693	0.8661	0.787		3820	5240				0.6693	0.6690	0.8664	0.8669	
	17	23	15.0	K17X23X15F	14.1	16.3	18000	27000	0.0251	17.000	16.992	23.007	23.020	0.010
	0.6693	0.9055	0.591		3170	3660				0.6693	0.6690	0.9058	0.9063	
18	18	22	8.0	K18X22X8F	6.32	7.70	16000	24000	0.0224	18.000	17.992	22.007	22.020	0.005
	0.7087	0.8661	0.315		1420	1730				0.7087	0.7083	0.8664	0.8669	
	18	22	10.0	K18X22X10	8.41	11.1	16000	24000	0.0246	18.000	17.992	22.007	22.020	0.006
	0.7087	0.8661	0.394		1890	2500				0.7087	0.7083	0.8664	0.8669	
	18	22	10.0	K18X22X10H	8.41	11.1	16000	24000	0.0246	18.000	17.992	22.007	22.020	0.006
	0.7087	0.8661	0.394		1890	2500				0.7087	0.7083	0.8664	0.8669	
	18	22	13.0	K18X22X13H	10.8	15.4	16000	24000	0.0266	18.000	17.992	22.007	22.020	0.008
	0.7087	0.8661	0.512		2430	3460				0.7087	0.7083	0.8664	0.8669	
	18	22	14.0	K18X22X14	11.6	16.8	16000	24000	0.0272	18.000	17.992	22.007	22.020	0.009
	0.7087	0.8661	0.551		2610	3780				0.7087	0.7083	0.8664	0.8669	
	18	22	14.0	K18X22X14FV	11.3	16.3	16000	24000	0.0270	18.000	17.992	22.007	22.020	0.009
	0.7087	0.8661	0.551		2540	3660				0.7087	0.7083	0.8664	0.8669	
	18	22	17.0	K18X22X17H	13.3	19.9	16000	24000	0.0284	18.000	17.992	22.007	22.020	0.009
	0.7087	0.8661	0.669		2990	4470				0.7087	0.7083	0.8664	0.8669	
	18	22	20.0	K18X22X20F	15.0	23.4	16000	24000	0.0296	18.000	17.992	22.007	22.020	0.011
	0.7087	0.8661	0.787		3370	5260				0.7087	0.7083	0.8664	0.8669	
	18	24	12.0	K18X24X12	11.8	13.1	17000	25000	0.0243	18.000	17.992	24.007	24.020	0.011
	0.7087	0.9449	0.472		2650	2940				0.7087	0.7083	0.9452	0.9457	
	18	24	20.0	K18X24X20H	19.4	24.9	16000	25000	0.0285	18.000	17.992	24.007	24.020	0.019
	0.7087	0.9449	0.787		4360	5600				0.7087	0.7083	0.9452	0.9457	
	18	25	22.0	K18X25X22H	23.3	28.6	17000	26000	0.0291	18.000	17.992	25.007	25.020	0.025
	0.7087	0.9843	0.866		5240	6430				0.7087	0.7083	0.9845	0.9850	
	18	26	12.0	K18X26X12FV	13.8	13.5	11000	17000	0.0238	18.000	17.992	26.007	26.020	0.020
	0.7087	1.0236	0.472		3100	3030				0.7087	0.7083	1.0239	1.0244	
	18	26	20.0	K18X26X20FZB2	21.7	24.1	17000	26000	0.0275	18.000	17.992	26.007	26.020	0.027
	0.7087	1.0236	0.787		4880	5420				0.7087	0.7083	1.0239	1.0244	
19	19	23	13.0	K19X23X13	10.8	15.5	15000	23000	0.0273	19.000	18.991	23.007	23.020	0.008
	0.7480	0.9055	0.512		2430	3480				0.7480	0.7477	0.9058	0.9063	
	19	23	17.0	K19X23X17	13.4	20.6	15000	23000	0.0293	19.000	18.991	23.007	23.020	0.011
	0.7480	0.9055	0.669		3010	4630				0.7480	0.7477	0.9058	0.9063	
20	20	24	8.0	K20X24X8F	7.31	9.60	14000	22000	0.0248	20.000	19.991	24.007	24.020	0.005
	0.7874	0.9449	0.315		1640	2160				0.7874	0.7870	0.9452	0.9457	
	20	24	10.0	K20X24X10	8.97	12.5	14000	22000	0.0265	20.000	19.991	24.007	24.020	0.006
	0.7874	0.9449	0.394		2020	2810				0.7874	0.7870	0.9452	0.9457	
	20	24	10.0	K20X24X10H	8.97	12.5	14000	22000	0.0265	20.000	19.991	24.007	24.020	0.006
	0.7874	0.9449	0.394		2020	2810				0.7874	0.7870	0.9452	0.9457	
	20	24	12.0	K20X24X12	10.7	15.7	14000	22000	0.0280	20.000	19.991	24.007	24.020	0.008
	0.7874	0.9449	0.472		2410	3530				0.7874	0.7870	0.9452	0.9457	
	20	24	13.0	K20X24X13	11.5	17.3	14000	22000	0.0287	20.000	19.991	24.007	24.020	0.008
	0.7874	0.9449	0.512		2590	3890				0.7874	0.7870	0.9452	0.9457	
	20	24	13.0	K20X24X13H	11.5	17.3	14000	22000	0.0287	20.000	19.991	24.007	24.020	0.009
	0.7874	0.9449	0.512		2590	3890				0.7874	0.7870	0.9452	0.9457	
	20	24	14.0	K20X24X14	12.4	18.9	14000	22000	0.0293	20.000	19.991	24.007	24.020	0.009
	0.7874	0.9449	0.551		2790	4250				0.7874	0.7870	0.9452	0.9457	
	20	24	17.0	K20X24X17H	14.8	23.7	14000	22000	0.0310	20.000	19.991	24.007	24.020	0.011
	0.7874	0.9449	0.669		3330	5330				0.7874	0.7870	0.9452	0.9457	
	20	26	12.0	K20X26X12	13.0	15.3	15000	23000	0.0264	20.000	19.991	26.007	26.020	0.012
	0.7874	1.0236	0.472		2920	3440				0.7874	0.7870	1.0239	1.0244	

Continued on next page.



NEEDLE ROLLER BEARINGS

SINGLE-ROW, DOUBLE-ROW ASSEMBLIES — *continued*

METRIC SERIES

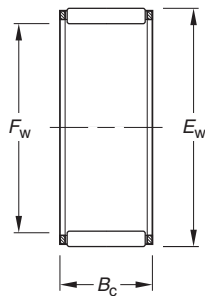

K

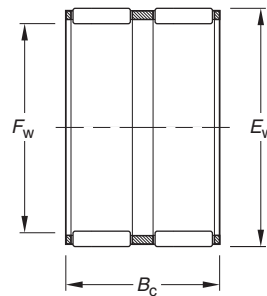

K.ZW

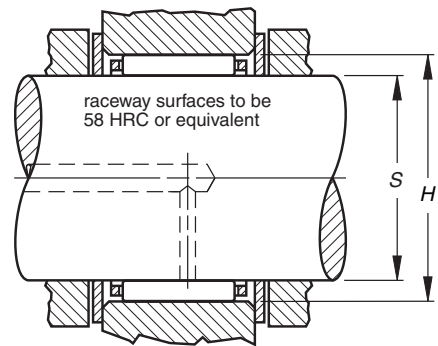

Shaft Dia.	Dimensions mm/in.			Assembly Designation	Load Ratings		Limiting Speed		Mounting Dimensions mm/in.	Wt. kg/lbs.				
	F _w	E _w	B _c		C	C ₀	Grease	Oil			Max.	Min.	Min.	Max.
mm	mm	mm	mm		kN	lb.f.	RPM	RPM	S	H				
20	20	26	13.0	K20X26X13H	13.4	15.9	15000	23000	0.0267	20.000	19.991	26.007	26.020	0.014
	0.7874	1.0236	0.512		3010	3570								
20	20	26	17.0	K20X26X17H	19.3	25.5	15000	23000	0.0300	20.000	19.991	26.007	26.020	0.017
	0.7874	1.0236	0.669		4340	5730								
20	20	26	20.0	K20X26X20	20.3	27.2	15000	23000	0.0305	20.000	19.991	26.007	26.020	0.020
	0.7874	1.0236	0.787		4560	6110								
20	20	28	20.0	K20X28X20H	24.6	29.0	15000	23000	0.0300	20.000	19.991	28.007	28.020	0.028
	0.7874	1.1024	0.787		5530	6520								
20	20	28	25.0	K20X28X25H	29.7	37.0	15000	23000	0.0319	20.000	19.991	28.007	28.020	0.036
	0.7874	1.1024	0.984		6680	8320								
20	20	30	30.0	K20X30X30H	38.9	45.8	16000	24000	0.0329	20.000	19.991	30.007	30.020	0.055
	0.7874	1.1811	1.181		8750	10300								
20	20	32	36.0	K20X32X36H	49.9	57.0	16000	25000	0.0344	20.000	19.991	32.009	32.025	0.082
	0.7874	1.2598	1.417		11220	12810								
21	21	25	17.0	K21X25X17F	14.3	23.1	14000	21000	0.0315	21.000	20.991	25.007	25.020	0.012
	0.8268	0.9843	0.669		3210	5190								
21	21	25	17.0	K21X25X17H	14.3	23.1	14000	21000	0.0315	21.000	20.991	25.007	25.020	0.013
	0.8268	0.9843	0.669		3210	5190								
22	22	26	10.0	K22X26X10H	9.81	14.5	13000	20000	0.0291	22.000	21.991	26.007	26.020	0.007
	0.8661	1.0236	0.394		2210	3260								
22	22	26	13.0	K22X26X13H	11.8	18.3	13000	20000	0.0303	22.000	21.991	26.007	26.020	0.012
	0.8661	1.0236	0.512		2650	4110								
22	22	26	17.0	K22X26X17	15.6	26.3	13000	20000	0.0332	22.000	21.991	26.007	26.020	0.015
	0.8661	1.0236	0.669		3510	5910								
22	22	26	17.0	K22X26X17H	15.6	26.3	13000	20000	0.0332	22.000	21.991	26.007	26.020	0.012
	0.8661	1.0236	0.669		3510	5910								
22	22	26	18.0	K22X26X18H	15.3	25.5	13000	20000	0.0329	22.000	21.991	26.007	26.020	0.017
	0.8661	1.0236	0.709		3440	5730								
22	22	28	13.0	K22X28X13	13.9	17.1	13000	20000	0.0283	22.000	21.991	28.007	28.020	0.015
	0.8661	1.1024	0.512		3120	3840								
22	22	28	17.0	K22X28X17H	18.2	24.2	13000	20000	0.0308	22.000	21.991	28.007	28.020	0.020
	0.8661	1.1024	0.669		4090	5440								
22	22	30	15.0	K22X30X15H	19.7	22.3	14000	21000	0.0292	22.000	21.991	30.007	30.020	0.023
	0.8661	1.1811	0.591		4430	5010								
22	22	30	20.0	K22X30X20FV	24.4	29.4	14000	21000	0.0313	22.000	21.991	30.007	30.020	0.031
	0.8661	1.1811	0.787		5490	6610								
22	22	32	24.0	K22X32X24F	33.1	37.9	14000	22000	0.0326	22.000	21.991	32.009	32.025	0.046
	0.8661	1.2598	0.945		7440	8520								
22	22	32	30.0	K22X32X30H	41.8	51.3	14000	22000	0.0351	22.000	21.991	32.009	32.025	0.057
	0.8661	1.2598	1.181		9400	11530								
23	23	28	24.0	K23X28X24F	22.4	36.2	12000	19000	0.0355	23.000	22.991	28.007	28.020	0.023
	0.9055	1.1024	0.945		5040	8140								
23	23	35	16.0	K23X35X16H.ZB2	25.9	25.1	14000	21000	0.0294	23.000	22.991	35.009	35.025	0.040
	0.9055	1.3780	0.630		5820	5640								
23	23	35	16.2	K23X35X16.2H	29.1	29.3	14000	21000	0.0306	23.000	22.991	35.009	35.025	0.040
	0.9055	1.3780	0.638		6540	6590								

Shaft Dia.	Dimensions mm/in.			Assembly Designation	Load Ratings		Limiting Speed		C _g	Mounting Dimensions mm/in.				Wt. kg/lbs.
	-0.2 - .008 -0.55 - .022				kN/lbf.		Grease	Oil		Max.	Min.	Min.	Max.	
	mm	F _w	E _w		B _c	C	C ₀	RPM		S	H			
24	24	28	10.0	K24X28X10H	9.67	14.6	12000	18000	0.0298	24.000	23.991	28.007	28.020	0.027
	0.9449	1.1024	0.394		2170	3280				0.9449	0.9445	1.1026	1.1031	0.060
	24	28	13.0	K24X28X13H	12.5	20.2	12000	18000	0.0323	24.000	23.991	28.007	28.020	0.010
	0.9449	1.1024	0.512		2810	4540				0.9449	0.9445	1.1026	1.1031	0.022
	24	28	16.0	K24X28X16F						24.000	23.991	28.007	28.020	
	0.9449	1.1024	0.630							0.9449	0.9445	1.1026	1.1031	
	24	28	17.0	K24X28X17H	15.4	26.4	12000	18000	0.0345	24.000	23.991	28.007	28.020	0.013
	0.9449	1.1024	0.669		3460	5930				0.9449	0.9445	1.1026	1.1031	0.029
	24	30	10.0	K24X30X10TN	11.3	13.5	12000	19000	—	24.000	23.991	30.007	30.020	0.008
	0.9449	1.1811	0.394		2540	3030				0.9449	0.9445	1.1814	1.1819	0.018
25	24	30	17.0	K24X30X17H	19.8	27.7	12000	19000	0.0331	24.000	23.991	30.007	30.020	0.020
	0.9449	1.1811	0.669		4450	6230				0.9449	0.9445	1.1814	1.1819	0.044
	24	30	22.0	K24X30X22	25.0	37.3	12000	19000	0.0356	24.000	23.991	30.007	30.020	0.024
	0.9449	1.1811	0.866		5620	8390				0.9449	0.9445	1.1814	1.1819	0.053
	24	36	23.0	K24X36X23H	37.1	40.1	13000	20000	0.0336	24.000	23.991	36.009	36.025	0.070
	0.9449	1.4173	0.906		8340	9010				0.9449	0.9445	1.4177	1.4183	0.154
	25	29	10.0	K25X29X10H	9.61	14.6	11000	17000	0.0303	25.000	24.991	29.007	29.020	0.008
	0.9843	1.1417	0.394		2160	3280				0.9843	0.9839	1.1420	1.1425	0.018
	25	29	13.0	K25X29X13H	12.8	21.1	11000	17000	0.0332	25.000	24.991	29.007	29.020	0.010
	0.9843	1.1417	0.512		2880	4740				0.9843	0.9839	1.1420	1.1425	0.022
25	25	29	17.0	K25X29X17H	15.1	26.2	11000	17000	0.0351	25.000	24.991	29.007	29.020	0.016
	0.9843	1.1417	0.669		3390	5890				0.9843	0.9839	1.1420	1.1425	0.035
	25	30	13.0	K25X30X13	14.6	21.4	11000	17000	0.0323	25.000	24.991	30.007	30.020	0.012
	0.9843	1.1811	0.512		3280	4810				0.9843	0.9839	1.1814	1.1819	0.026
	25	30	17.0	K25X30X17H	18.8	29.8	11000	17000	0.0351	25.000	24.991	30.007	30.020	0.016
	0.9843	1.1811	0.669		4230	6700				0.9843	0.9839	1.1814	1.1819	0.035
	25	30	18.0	K25X30X18	20.6	33.4	11000	17000	0.0361	25.000	24.991	30.007	30.020	0.017
	0.9843	1.1811	0.709		4630	7510				0.9843	0.9839	1.1814	1.1819	0.037
	25	30	20.0	K25X30X20H	21.9	36.1	11000	17000	0.0368	25.000	24.991	30.007	30.020	0.019
	0.9843	1.1811	0.787		4920	8120				0.9843	0.9839	1.1814	1.1819	0.042
	25	30	24.0	K25X30X24H	24.8	42.4	11000	17000	0.0383	25.000	24.991	30.007	30.020	0.024
	0.9843	1.1811	0.945		5580	9530				0.9843	0.9839	1.1814	1.1819	0.053
	25	30	26.0	K25X30X26ZW	23.0	38.6	11000	17000	0.0374	25.000	24.991	30.007	30.020	0.027
	0.9843	1.1811	1.024		5170	8680				0.9843	0.9839	1.1814	1.1819	0.060
	25	31	14.0	K25X31X14H	16.8	22.7	12000	18000	0.0320	25.000	24.991	31.009	31.025	0.017
	0.9843	1.2205	0.551		3780	5100				0.9843	0.9839	1.2208	1.2215	0.037
	25	31	17.0	K25X31X17H	19.7	27.8	12000	18000	0.0337	25.000	24.991	31.009	31.025	0.020
	0.9843	1.2205	0.669		4430	6250				0.9843	0.9839	1.2208	1.2215	0.044
25	31	21.0	K25X31X21	25.1	38.0	12000	18000	0.0364	25.000	24.991	31.009	31.025	0.026	
0.9843	1.2205	0.827		5640	8540				0.9843	0.9839	1.2208	1.2215	0.057	
25	31	21.0	K25X31X21F	25.1	38.0	12000	18000	0.0364	25.000	24.991	31.009	31.025	0.026	
0.9843	1.2205	0.827		5640	8540				0.9843	0.9839	1.2208	1.2215	0.057	
25	31	21.0	K25X31X21H	25.1	38.0	12000	18000	0.0364	25.000	24.991	31.009	31.025	0.026	
0.9843	1.2205	0.827		5640	8540				0.9843	0.9839	1.2208	1.2215	0.057	
25	31	24.0	K25X31X24F	25.3	38.5	12000	18000	0.0365	25.000	24.991	31.009	31.025	0.031	
0.9843	1.2205	0.945		5690	8660				0.9843	0.9839	1.2208	1.2215	0.068	
25	31	24.0	K25X31X24FH	25.3	38.5	12000	18000	0.0365	25.000	24.991	31.009	31.025	0.031	
0.9843	1.2205	0.945		5690	8660				0.9843	0.9839	1.2208	1.2215	0.068	
25	32	16.0	K25X32X16	19.8	25.3	12000	18000	0.0323	25.000	24.991	32.009	32.025	0.027	
0.9843	1.2598	0.630		4450	5690				0.9843	0.9839	1.2602	1.2608	0.060	
25	33	20.0	K25X33X20FH.ZB2	25.6	32.3	12000	18000	0.0337	25.000	24.991	33.009	33.025	0.035	
0.9843	1.2992	0.787		5760	7260				0.9843	0.9839	1.2996	1.3002	0.077	
25	33	20.0	K25X33X20H	28.8	37.6	12000	18000	0.0350	25.000	24.991	33.009	33.025	0.035	
0.9843	1.2992	0.787		6470	8450				0.9843	0.9839	1.2996	1.3002	0.077	
25	33	24.0	K25X33X24H	32.3	43.5	12000	18000	0.0363	25.000	24.991	33.009	33.025	0.038	
0.9843	1.2992	0.945		7260	9780				0.9843	0.9839	1.2996	1.3002	0.084	
25	33	25.0	K25X33X25H	33.0	44.6	12000	18000	0.0365	25.000	24.991	33.009	33.025	0.041	
0.9843	1.2992	0.984		7420	10030				0.9843	0.9839	1.2996	1.3002	0.090	

Continued on next page.



NEEDLE ROLLER BEARINGS

SINGLE-ROW, DOUBLE-ROW ASSEMBLIES — *continued*

METRIC SERIES

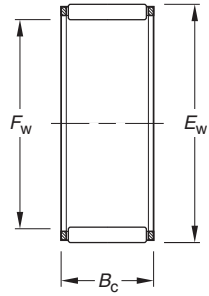

K

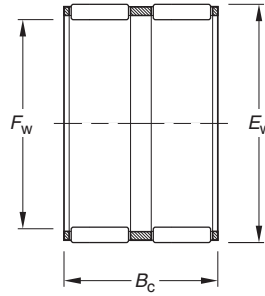

K.ZW

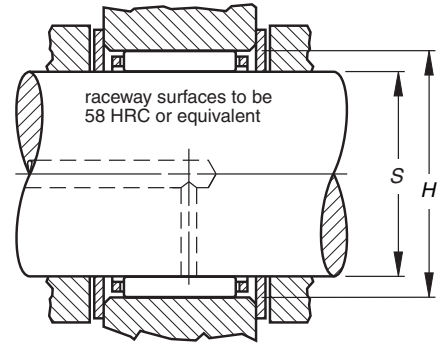

Shaft Dia.	Dimensions mm/in.			Assembly Designation	Load Ratings		Limiting Speed			Mounting Dimensions mm/in.				Wt. kg/lbs.
	-0.2 -0.08 -0.55 -0.22				C	Co	Grease	Oil	Max.	Min.	Min.	Max.		
mm	Fw	Ew	Bc		C	Co	RPM		Cg	S		H		
25	25	35	23.7	K25X35X23,7H	35.9	42.3	12000	19000	0.0354	25.000	24.991	35.009	35.025	0.050
	0.9843	1.3780	0.933		8070	9510								
25	25	35	25.0	K25X35X25H	37.8	46.2	12000	19000	0.0360	25.000	24.991	35.009	35.025	0.054
	0.9843	1.3780	0.984		8500	10390								
25	25	35	30.0	K25X35X30H	44.6	57.2	12000	19000	0.0379	25.000	24.991	35.009	35.025	0.060
	0.9843	1.3780	1.181		10030	12860								
25	25	35	30.0	K25X35X30H.ZB2	44.6	57.2	12000	19000	0.0379	25.000	24.991	35.009	35.025	0.060
	0.9843	1.3780	1.181		10030	12860								
25	25	35	36.0	K25X35X36H	52.4	70.4	12000	19000	0.0399	25.000	24.991	35.009	35.025	0.074
	0.9843	1.3780	1.417		11780	15830								
25	25	37	20.0	K25X37X20H	32.5	34.1	12000	19000	0.0328	25.000	24.991	37.009	37.025	0.055
	0.9843	1.4567	0.787		7310	7670								
26	26	30	10.0	K26X30X10F	9.46	14.5	11000	16000	0.0308	26.000	25.991	30.007	30.020	0.007
	1.0236	1.1811	0.394		2130	3260								
26	26	30	13.0	K26X30X13	12.3	20.4	10000	16000	0.0335	26.000	25.991	30.007	30.020	0.011
	1.0236	1.1811	0.512		2770	4590								
26	26	30	17.0	K26X30X17	15.0	26.3	10000	16000	0.0357	26.000	25.991	30.007	30.020	0.014
	1.0236	1.1811	0.669		3370	5910								
26	26	30	22.0	K26X30X22ZW	16.7	30.2	10000	16000	0.0370	26.000	25.991	30.007	30.020	0.018
	1.0236	1.1811	0.866		3750	6790								
28	28	32	21.0	K28X32X21F	18.7	35.7	9900	15000	0.0398	28.000	27.991	32.009	32.025	0.018
	1.1024	1.2598	0.827		4200	8030								
28	28	33	13.0	K28X33X13F	14.1	21.4	10000	15000	0.0339	28.000	27.991	33.009	33.025	0.015
	1.1024	1.2992	0.512		3170	4810								
28	28	33	13.0	K28X33X13FV	14.1	21.4	10000	15000	0.0339	28.000	27.991	33.009	33.025	0.015
	1.1024	1.2992	0.512		3170	4810								
28	28	33	17.0	K28X33X17H	19.8	33.0	10000	15000	0.0378	28.000	27.991	33.009	33.025	0.018
	1.1024	1.2992	0.669		4450	7420								
28	28	33	27.0	K28X33X27	29.0	53.8	10000	15000	0.0427	28.000	27.991	33.009	33.025	0.027
	1.1024	1.2992	1.063		6520	12090								
28	28	34	17.0	K28X34X17	21.1	31.5	10000	16000	0.0364	28.000	27.991	34.009	34.025	0.022
	1.1024	1.3386	0.669		4740	7080								
28	28	34	20.0	K28X34X20H	24.4	37.8	10000	16000	0.0381	28.000	27.991	34.009	34.025	0.025
	1.1024	1.3386	0.787		5490	8500								
28	28	35	15.0	K28X35X15H	19.5	25.6	10000	16000	0.0339	28.000	27.991	35.009	35.025	0.025
	1.1024	1.3780	0.591		4380	5760								
28	28	35	16.0	K28X35X16FH	21.5	29.1	10000	16000	0.0350	28.000	27.991	35.009	35.025	0.026
	1.1024	1.3780	0.630		4830	6540								
28	28	35	16.0	K28X35X16H	21.5	29.1	10000	16000	0.0350	28.000	27.991	35.009	35.025	0.026
	1.1024	1.3780	0.630		4830	6540								
28	28	35	27.0	K28X35X27H	35.2	54.7	10000	16000	0.0409	28.000	27.991	35.009	35.025	0.042
	1.1024	1.3780	1.063		7910	12300								
28	28	36	20.0	K28X36X20FV	27.8	37.0	10000	16000	0.0365	28.000	27.991	36.009	36.025	0.039
	1.1024	1.4173	0.787		6250	8320								
28	28	38	25.5	K28X38X25,5	40.9	52.7	11000	16000	0.0389	28.000	27.991	38.009	38.025	0.059
	1.1024	1.4961	1.004		9190	11850								

Shaft Dia.	Dimensions mm/in. -0.2 -.008 -0.55 -.022			Assembly Designation	Load Ratings kN/lbf.		Limiting Speed		C _g	Mounting Dimensions mm/in.				Wt. kg/lbs.
	F _w	E _w	B _c		C	C ₀	Grease	Oil		Max.	Min.	Min.	Max.	
mm							RPM		S		H			
28	28	40	18.0	K28X40X18H	33.6	36.5	11000	17000	0.0349	28.000	27.991	40.009	40.025	0.060
	1.1024	1.5748	0.709		7550	8210				1.1024	1.1020	1.5752	1.5758	
28	28	40	25.0	K28X40X25H	45.5	54.0	11000	17000	0.0384	28.000	27.991	40.009	40.025	0.072
	1.1024	1.5748	0.984		10230	12140				1.1024	1.1020	1.5752	1.5758	
28	28	40	30.0	K28X40X30H	54.3	67.8	11000	17000	0.0406	28.000	27.991	40.009	40.025	0.100
	1.1024	1.5748	1.181		12210	15240				1.1024	1.1020	1.5752	1.5758	
28	28	41	25.0	K28X41X25H	49.2	57.1	11000	17000	0.0386	28.000	27.991	41.009	41.025	0.082
	1.1024	1.6142	0.984		11060	12840				1.1024	1.1020	1.6145	1.6152	
29	29	34	27.0	K29X34X27F	28.9	54.0	9700	15000	0.0434	29.000	28.991	34.009	34.025	0.033
	1.1417	1.3386	1.063		6500	12140				1.1417	1.1414	1.3389	1.3396	0.073
30	30	34	13.0	K30X34X13	13.5	24.1	9200	14000	0.0372	30.000	29.991	34.009	34.025	0.011
	1.1811	1.3386	0.512		3030	5420				1.1811	1.1807	1.3389	1.3396	
30	30	35	13.0	K30X35X13H	15.6	24.9	9300	14000	0.0363	30.000	29.991	35.009	35.025	0.017
	1.1811	1.3780	0.512		3510	5600				1.1811	1.1807	1.3783	1.3789	
30	30	35	17.0	K30X35X17H	20.2	34.6	9300	14000	0.0394	30.000	29.991	35.009	35.025	0.022
	1.1811	1.3780	0.669		4540	7780				1.1811	1.1807	1.3783	1.3789	
30	30	35	20.0	K30X35X20H	23.5	41.9	9300	14000	0.0413	30.000	29.991	35.009	35.025	0.023
	1.1811	1.3780	0.787		5280	9420				1.1811	1.1807	1.3783	1.3789	
30	30	35	22.8	K30X35X23F	25.6	46.8	9300	14000	0.0425	30.000	29.991	35.009	35.025	0.028
	1.1811	1.3780	0.898		5760	10520				1.1811	1.1807	1.3783	1.3789	
30	30	35	27.0	K30X35X27H	30.6	59.0	9300	14000	0.0450	30.000	29.991	35.009	35.025	0.032
	1.1811	1.3780	1.063		6880	13260				1.1811	1.1807	1.3783	1.3789	
30	30	35	27.0	K30X35X27HZW	19.9	33.6	9300	14000	0.0391	30.000	29.991	35.009	35.025	0.033
	1.1811	1.3780	1.063		4470	7550				1.1811	1.1807	1.3783	1.3789	
30	30	36	14.0	K30X36X14	18.0	26.2	9500	15000	0.0358	30.000	29.991	36.009	36.025	0.020
	1.1811	1.4173	0.551		4050	5890				1.1811	1.1807	1.4177	1.4183	
30	30	37	17.8	K30X37X18	24.3	34.8	9600	15000	0.0377	30.000	29.991	37.009	37.025	0.033
	1.1811	1.4567	0.701		5460	7820				1.1811	1.1807	1.4570	1.4577	
30	30	37	18.0	K30X37X18FV	24.3	34.8	9600	15000	0.0377	30.000	29.991	37.009	37.025	0.033
	1.1811	1.4567	0.709		5460	7820				1.1811	1.1807	1.4570	1.4577	
30	30	40	30.0	K30X40X30H	49.2	67.8	9900	15000	0.0426	30.000	29.991	40.009	40.025	0.077
	1.1811	1.5748	1.181		11060	15240				1.1811	1.1807	1.5752	1.5758	
30	30	42	30.0	K30X42X30H	54.2	68.6	10000	16000	0.0419	30.000	29.991	42.009	42.025	0.096
	1.1811	1.6535	1.181		12180	15420				1.1811	1.1807	1.6539	1.6545	
30	30	44	26.0	K30X44X26H	52.4	59.9	10000	16000	0.0399	30.000	29.991	44.009	44.025	0.095
	1.1811	1.7323	1.024		11780	13470				1.1811	1.1807	1.7326	1.7333	
31	31	37	24.0	K30,6X36,6X24FV	27.8	46.2	9300	14000	0.0416	30.600	30.591	36.609	36.625	0.038
	1.2047	1.4409	0.945		6250	10390				1.2047	1.2044	1.4413	1.4419	0.084
32	32	36	15.0	K32X36X15F	11.6	20.2	8600	13000	0.0367	32.000	31.989	36.009	36.025	0.015
	1.2598	1.4173	0.591		2610	4540				1.2598	1.2594	1.4177	1.4183	
32	32	37	13.0	K32X37X13	15.2	24.4	8700	13000	0.0372	32.000	31.989	37.009	37.025	0.018
	1.2598	1.4567	0.512		3420	5490				1.2598	1.2594	1.4570	1.4577	
32	32	37	17.0	K32X37X17H	20.0	34.8	8700	13000	0.0406	32.000	31.989	37.009	37.025	0.020
	1.2598	1.4567	0.669		4500	7820				1.2598	1.2594	1.4570	1.4577	
32	32	37	27.0	K32X37X27	29.3	56.8	8700	13000	0.0459	32.000	31.989	37.009	37.025	0.035
	1.2598	1.4567	1.063		6590	12770				1.2598	1.2594	1.4570	1.4577	
32	32	38	20.0	K32X38X20H	27.3	45.7	8800	14000	0.0423	32.000	31.989	38.009	38.025	0.030
	1.2598	1.4961	0.787		6140	10270				1.2598	1.2594	1.4964	1.4970	
32	32	38	26.0	K32X38X26H	33.2	58.8	8800	14000	0.0451	32.000	31.989	38.009	38.025	0.037
	1.2598	1.4961	1.024		7460	13220				1.2598	1.2594	1.4964	1.4970	
32	32	39	16.0	K32X39X16H	23.0	33.0	8900	14000	0.0382	32.000	31.989	39.009	39.025	0.030
	1.2598	1.5354	0.630		5170	7420				1.2598	1.2594	1.5358	1.5364	
32	32	39	18.0	K32X39X18H	25.8	38.2	8900	14000	0.0397	32.000	31.989	39.009	39.025	0.033
	1.2598	1.5354	0.709		5800	8590				1.2598	1.2594	1.5358	1.5364	
32	32	40	25.0	K32X40X25H	37.9	57.2	9000	14000	0.0431	32.000	31.989	40.009	40.025	0.052
	1.2598	1.5748	0.984		8520	12860				1.2598	1.2594	1.5752	1.5758	
32	32	40	36.0	K32X40X36H	52.3	86.4	9000	14000	0.0477	32.000	31.989	40.009	40.025	0.080
	1.2598	1.5748	1.417		11760	19420				1.2598	1.2594	1.5752	1.5758	

Continued on next page.



NEEDLE ROLLER BEARINGS

SINGLE-ROW, DOUBLE-ROW ASSEMBLIES — continued

METRIC SERIES

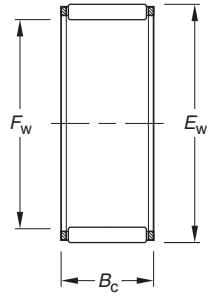

K

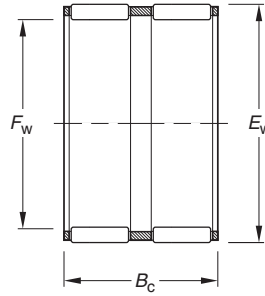

K.ZW

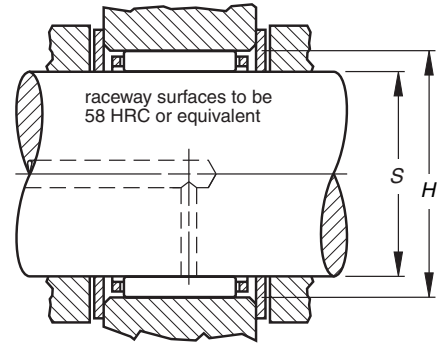

Shaft Dia.	Dimensions mm/in.			Assembly Designation	Load Ratings		Limiting Speed		Mounting Dimensions mm/in.	Wt. kg/lbs.				
	F _w	E _w	B _c		C	C ₀	Grease	Oil			Max.	Min.	Min.	Max.
mm	mm	mm	mm				RPM	C ₉	S	H				
32	32	42	42.0	K32X42X42H	69.2	108	9200	14000	0.0491	32.000	31.989	42.009	42.025	0.110
	1.2598	1.6535	1.654		15560	24280				1.2598	1.2594	1.6539	1.6545	
32	32	46	18.0	K32X46X18H	39.2	41.9	9600	15000	0.0374	32.000	31.989	46.009	46.025	0.075
	1.2598	1.8110	0.709		8810	9420				1.2598	1.2594	1.8114	1.8120	
32	32	46	32.0	K32X46X32H	67.0	83.4	9600	15000	0.0444	32.000	31.989	46.009	46.025	0.140
	1.2598	1.8110	1.260		15060	18750				1.2598	1.2594	1.8114	1.8120	
32	32	46	40.0	K32X46X40H	81.7	108	9600	15000	0.0473	32.000	31.989	46.009	46.025	0.158
	1.2598	1.8110	1.575		18370	24280				1.2598	1.2594	1.8114	1.8120	
33	33	51	23.0	K33X51X23H.ZB2	55.9	57.6	9600	15000	0.0401	33.000	32.989	51.010	51.029	0.140
	1.2992	2.0079	0.906		12570	12950				1.2992	1.2988	2.0083	2.0090	0.309
34	34	38	11.0	K34X38X11	12.2	21.9	8100	12000	0.0385	34.000	33.989	38.009	38.025	0.011
	1.3386	1.4961	0.433		2740	4920				1.3386	1.3381	1.4964	1.4970	
34	34	44	26.0	K34X44X26FH	42.9	58.9	8600	13000	0.0433	34.000	33.989	44.009	44.025	0.080
	1.3386	1.7323	1.024		9640	13240				1.3386	1.3381	1.7326	1.7333	
34	34	44	26.0	K34X44X26FV	42.9	58.9	8600	13000	0.0433	34.000	33.989	44.009	44.025	0.075
	1.3386	1.7323	1.024		9640	13240				1.3386	1.3381	1.7326	1.7333	
35	35	40	13.0	K35X40X13H	16.2	27.2	7900	12000	0.0398	35.000	34.989	40.009	40.025	0.018
	1.3780	1.5748	0.512		3640	6110				1.3780	1.3775	1.5752	1.5758	
35	35	40	17.0	K35X40X17H	22.1	40.8	7900	12000	0.0440	35.000	34.989	40.009	40.025	0.025
	1.3780	1.5748	0.669		4970	9170				1.3780	1.3775	1.5752	1.5758	
35	35	40	19.0	K35X40X19F.ZB2	23.2	43.2	7900	12000	0.0446	35.000	34.989	40.009	40.025	0.025
	1.3780	1.5748	0.748		5220	9710				1.3780	1.3775	1.5752	1.5758	
35	35	40	19.0	K35X40X19H.ZB2	23.2	43.2	7900	12000	0.0446	35.000	34.989	40.009	40.025	0.025
	1.3780	1.5748	0.748		5220	9710				1.3780	1.3775	1.5752	1.5758	
35	35	40	25.0	K35X40X25H	28.4	56.2	7900	12000	0.0476	35.000	34.989	40.009	40.025	0.035
	1.3780	1.5748	0.984		6380	12630				1.3780	1.3775	1.5752	1.5758	
35	35	40	27.0	K35X40X27H	29.8	59.6	7900	12000	0.0483	35.000	34.989	40.009	40.025	0.037
	1.3780	1.5748	1.063		6700	13400				1.3780	1.3775	1.5752	1.5758	
35	35	42	16.0	K35X42X16	24.5	36.8	8100	12000	0.0408	35.000	34.989	42.009	42.025	0.032
	1.3780	1.6535	0.630		5510	8270				1.3780	1.3775	1.6539	1.6545	
35	35	42	16.0	K35X42X16AH	24.5	36.8	8100	12000	0.0408	35.000	34.989	42.009	42.025	0.031
	1.3780	1.6535	0.630		5510	8270				1.3780	1.3775	1.6539	1.6545	
35	35	42	18.0	K35X42X18	27.5	42.6	8100	12000	0.0423	35.000	34.989	42.009	42.025	0.035
	1.3780	1.6535	0.709		6180	9580				1.3780	1.3775	1.6539	1.6545	
35	35	42	20.0	K35X42X20H	30.4	48.5	8100	12000	0.0437	35.000	34.989	42.009	42.025	0.037
	1.3780	1.6535	0.787		6830	10900				1.3780	1.3775	1.6539	1.6545	
35	35	42	30.0	K35X42X30FH	40.5	70.0	8100	12000	0.0479	35.000	34.989	42.009	42.025	0.061
	1.3780	1.6535	1.181		9100	15740				1.3780	1.3775	1.6539	1.6545	
35	35	45	20.0	K35X45X20FH	36.5	49.9	8400	13000	0.0421	35.000	34.989	45.009	45.025	0.059
	1.3780	1.7717	0.787		8210	11220				1.3780	1.3775	1.7720	1.7726	
35	35	45	30.0	K35X45X30F	51.2	74.5	8400	13000	0.0465	35.000	34.989	45.009	45.025	0.100
	1.3780	1.7717	1.181		11510	16750				1.3780	1.3775	1.7720	1.7726	
35	35	45	35.0	K35X45X35H	62.1	95.5	8400	13000	0.0494	35.000	34.989	45.009	45.025	0.085
	1.3780	1.7717	1.378		13960	21470				1.3780	1.3775	1.7720	1.7726	
35	35	45	41.0	K35X45X41	70.8	113	8400	13000	0.0515	35.000	34.989	45.009	45.025	0.120
	1.3780	1.7717	1.614		15920	25400				1.3780	1.3775	1.7720	1.7726	

Shaft Dia.	Dimensions mm/in.			Assembly Designation	Load Ratings		Limiting Speed		C _g	Mounting Dimensions mm/in.				Wt. kg/lbs.	
	-0.2 - .008 -0.55 - .022				kN/lbf.		Grease	Oil		Max.	Min.	Min.	Max.		
	mm	F _w	E _w		B _c	C	C ₀	RPM		C _g	S		H		
	35	45	49.0	K35X45X49H	82.5	138	8400	13000	0.0541	35.000	34.989	45.009	45.025	0.143	
	1.3780	1.7717	1.929		18550	31020				1.3780	1.3775	1.7720	1.7726		0.315
	35	45	49.0	K35X45X49HZW	71.8	115	8400	13000	0.0518	35.000	34.989	45.009	45.025	0.143	
	1.3780	1.7717	1.929		16140	25850				1.3780	1.3775	1.7720	1.7726		0.315
	35	48	22.8	K35X48X22.8H.ZB2	47.6	57.4	8600	13000	0.0423	35.000	34.989	48.009	48.025	0.100	
	1.3780	1.8898	0.898		10700	12900				1.3780	1.3775	1.8901	1.8907		0.220
	35	50	40.0	K35X50X40F	79.7	102	8700	13000	0.0480	35.000	34.989	50.009	50.025	0.200	
	1.3780	1.9685	1.575		17920	22930				1.3780	1.3775	1.9689	1.9695		0.441
36	36	40	29.0	K36X40X29TN	21.2	45.2	7600	12000	—	36.000	35.989	40.009	40.025	0.029	
	1.4173	1.5748	1.142		4770	10160				1.4173	1.4169	1.5752	1.5758		0.064
	36	42	16.0		K36X42X16	22.8				37.7	7800	12000	0.0425		36.000
1.4173	1.6535	0.630	5130	8480		1.4173	1.4169	1.6539	1.6545	0.060					
36	36	44	27.5	K36X44X27.5H	42.8	69.2	7900	12000	0.0475	36.000	35.989	44.009	44.025	0.064	
	1.4173	1.7323	1.083		9620	15560				1.4173	1.4169	1.7326	1.7333		0.14
	37	42	13.0		K37X42X13H	16.9				29.4	7500	11000	0.0416		37.000
1.4567	1.6535	0.512	3800	6610		1.4567	1.4563	1.6539	1.6545	0.037					
37	42	17.0	K37X42X17H	21.9		41.0	7500	11000	0.0451	37.000				36.989	42.009
1.4567	1.6535	0.669		4920	9220	1.4567				1.4563	1.6539	1.6545	0.055		
37	37	42	27.0	K37X42X27F	32.1	66.9	7500	11000	0.0510	37.000	36.989	42.009	42.025	0.039	
	1.4567	1.6535	1.063		7220	15040				1.4567	1.4563	1.6539	1.6545		0.086
	37	44	19.0		K37X44X19H	29.7				48.0	7600	12000	0.0447		37.000
1.4567	1.7323	0.748	6680	10790		1.4567	1.4563	1.7326	1.7333	0.086					
38	38	41	9.0	K38X41X9TN	5.93	11.0	7100	11000	—	38.000	37.989	41.009	41.025	0.004	
	1.4961	1.6142	0.354		1330	2470				1.4961	1.4956	1.6145	1.6152		0.009
	38	43	17.0		K38X43X17F	21.8				41.0	7300	11000	0.0457		38.000
1.4961	1.6929	0.669	4900	9220		1.4961	1.4956	1.6933	1.6939	0.071					
38	38	43	17.0	K38X43X17H	21.8	41.0	7300	11000	0.0457	38.000	37.989	43.009	43.025	0.032	
	1.4961	1.6929	0.669		4900	9220				1.4961	1.4956	1.6933	1.6939		0.071
	38	43	27.0		K38X43X27	31.9				67.0	7300	11000	0.0516		38.000
1.4961	1.6929	1.063	7170	15060		1.4961	1.4956	1.6933	1.6939	0.090					
38	38	46	19.8	K38X46X20	33.3	51.0	7500	12000	0.0450	38.000	37.989	46.009	46.025	0.055	
	1.4961	1.8110	0.780		7490	11470				1.4961	1.4956	1.8114	1.8120		0.121
	38	46	19.8		K38X46X20H	33.3				51.0	7500	12000	0.0450		38.000
1.4961	1.8110	0.780	7490	11470		1.4961	1.4956	1.8114	1.8120	0.121					
38	38	46	32.0	K38X46X32FV1	53.7	94.6	7500	12000	0.0525	38.000	37.989	46.009	46.025	0.080	
	1.4961	1.8110	1.260		12070	21270				1.4961	1.4956	1.8114	1.8120		0.176
	38	46	32.0		K38X46X32H	55.2				98.1	7500	12000	0.0530		38.000
1.4961	1.8110	1.260	12410	22050		1.4961	1.4956	1.8114	1.8120	0.198					
38	38	50	25.0	K38X50X25	53.0	70.8	7800	12000	0.0464	38.000	37.989	50.009	50.025	0.100	
	1.4961	1.9685	0.984		11910	15920				1.4961	1.4956	1.9689	1.9695		0.220
	38	50	33.0		K38X50X33H	68.3				98.2	7800	12000	0.0504		38.000
1.4961	1.9685	1.299	15350	22080		1.4961	1.4956	1.9689	1.9695	0.278					
38	38	50	40.0	K38X50X40FCH1	76.2	113	7800	12000	0.0521	38.000	37.989	50.009	50.025	0.170	
	1.4961	1.9685	1.575		17130	25400				1.4961	1.4956	1.9689	1.9695		0.375
	40	45	13.0		K40X45X13H	17.6				31.7	6900	11000	0.0438		40.000
1.5748	1.7717	0.512	3960	7130		1.5748	1.5744	1.7720	1.7726	0.049					
40	45	17.0	K40X45X17CH	19.2		35.3	6900	11000	0.0450	40.000				39.989	45.009
1.5748	1.7717	0.669		4320	7940	1.5748				1.5744	1.7720	1.7726	0.060		
40	40	45	17.0	K40X45X17H	23.8	47.0	6900	11000	0.0484	40.000	39.989	45.009	45.025	0.030	
	1.5748	1.7717	0.669		5350	10570				1.5748	1.5744	1.7720	1.7726		0.066
	40	45	18.0		K40X45X18H	25.1				50.4	6900	11000	0.0492		40.000
1.5748	1.7717	0.709	5640	11330		1.5748	1.5744	1.7720	1.7726	0.068					
40	40	45	21.0	K40X45X21CH	23.3	45.2	6900	11000	0.0479	40.000	39.989	45.009	45.025	0.033	
	1.5748	1.7717	0.827		5240	10160				1.5748	1.5744	1.7720	1.7726		0.073
	40	45	27.0		K40X45X27H	32.7				70.2	6900	11000	0.0534		40.000
1.5748	1.7717	1.063	7350	15780		1.5748	1.5744	1.7720	1.7726	0.088					
40	40	45	27.0	K40X45X27TN	33.3	72.1	6900	11000	0.0538	40.000	39.989	45.009	45.025	0.030	
	1.5748	1.7717	1.063		7490	16210				1.5748	1.5744	1.7720	1.7726		0.066

Continued on next page.



NEEDLE ROLLER BEARINGS

SINGLE-ROW, DOUBLE-ROW ASSEMBLIES — *continued*

METRIC SERIES

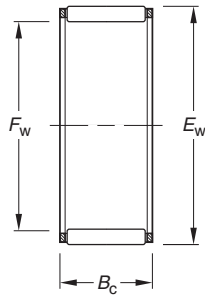

K

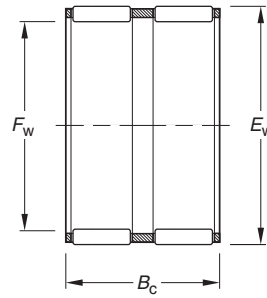

K.ZW

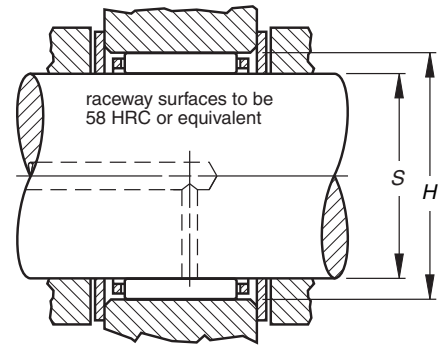

Shaft Dia.	Dimensions mm/in.			Assembly Designation	Load Ratings		Limiting Speed			Mounting Dimensions mm/in.				Wt. kg/lbs.
	-0.2 -0.08 -0.55 -0.22				kN/lbf.		Grease Oil		Max. Min.		Min. Max.			
	mm	Fw	Ew		Bc	C	Co	RPM		Ca	S		H	
	40	45	29.0	K40X45X29H	34.7	75.9	6900	11000	0.0545	40.000	39.989	45.009	45.025	0.050
	1.5748	1.7717	1.142		7800	17060								
	40	46	17.0	K40X46X17	25.2	44.0	7000	11000	0.0464	40.000	39.989	46.009	46.025	0.033
	1.5748	1.8110	0.669		5670	9890								
	40	47	18.0	K40X47X18	28.0	45.6	7000	11000	0.0456	40.000	39.989	47.009	47.025	0.041
	1.5748	1.8504	0.709		6290	10250								
	40	47	20.0	K40X47X20	31.1	52.1	7000	11000	0.0472	40.000	39.989	47.009	47.025	0.042
	1.5748	1.8504	0.787		6990	11710								
	40	48	20.0	K40X48X20FV1	35.5	56.3	7100	11000	0.0472	40.000	39.989	48.009	48.025	0.052
	1.5748	1.8898	0.787		7980	12660								
	40	48	20.0	K40X48X20H	35.5	56.3	7100	11000	0.0472	40.000	39.989	48.009	48.025	0.050
	1.5748	1.8898	0.787		7980	12660								
	40	48	35.0	K40X48X35H.ZB2	57.3	104	7100	11000	0.0550	40.000	39.989	48.009	48.025	0.098
	1.5748	1.8898	1.378		12880	23380								
	40	50	27.0	K40X50X27H	53.0	81.0	7200	11000	0.0502	40.000	39.989	50.009	50.025	0.084
	1.5748	1.9685	1.063		11910	18210								
	40	55	45.0	K40X55X45H	103	146	7500	12000	0.0554	40.000	39.989	55.010	55.029	0.221
	1.5748	2.1654	1.772		23160	32820								
	40	56	26.0	K40X56X26H	63.7	75.7	7600	12000	0.0467	40.000	39.989	56.010	56.029	0.138
	1.5748	2.2047	1.024		14320	17020								
41	41	48	31.0	K41X48X31HZW	38.0	68.1	6800	11000	0.0510	41.000	40.989	48.009	48.025	0.067
	1.6142	1.8898	1.220	8540	15310	1.6142	1.6137	1.8901	1.8907	0.148				
	42	42	47	13.0	K42X47X13H	18.7	34.9	6500	10000	0.0459	42.000	41.989	47.009	47.025
1.6535	1.8504	0.512	4200	7850		1.6535	1.6531							
	42	47	17.0	K42X47X17H	22.8	45.2	6500	10000	0.0490	42.000	41.989	47.009	47.025	0.028
	1.6535	1.8504	0.669		5130	10160								
	42	47	27.0	K42X47X27FH	33.8	74.7	6500	10000	0.0555	42.000	41.989	47.009	47.025	0.041
	1.6535	1.8504	1.063		7600	16790								
	42	47	27.0	K42X47X27H	33.8	74.7	6500	10000	0.0555	42.000	41.989	47.009	47.025	0.041
	1.6535	1.8504	1.063		7600	16790								
	42	48	24.0	K42X48X24F	33.1	63.9	6600	10000	0.0519	42.000	41.989	48.009	48.025	0.046
	1.6535	1.8898	0.945		7440	14370								
	42	50	13.0	K42X50X13H	20.9	28.9	6700	10000	0.0409	42.000	41.989	50.009	50.025	0.035
	1.6535	1.9685	0.512		4700	6500								
	42	50	20.0	K42X50X20H	35.2	56.6	6700	10000	0.0483	42.000	41.989	50.009	50.025	0.054
	1.6535	1.9685	0.787		7910	12720								
	42	50	30.0	K42X50X30H.ZB2	51.3	91.9	6700	10000	0.0545	42.000	41.989	50.009	50.025	0.080
	1.6535	1.9685	1.181		11530	20660								
	42	54	30.7	K42X54X30.7H	62.7	90.1	7000	11000	0.0514	42.000	41.989	54.010	54.029	0.140
	1.6535	2.1260	1.209		14100	20260								
43	43	48	17.0	K43X48X17FH	23.0	45.8	6400	9800	0.0496	43.000	42.989	48.009	48.025	0.036
	1.6929	1.8898	0.669		5170	10300								
	43	48	27.0	K43X48X27H	34.8	78.0	6400	9800	0.0567	43.000	42.989	48.009	48.025	0.050
	1.6929	1.8898	1.063		7820	17540								
44	44	50	22.0	K44X50X22	31.6	60.6	6400	9900	0.0523	44.000	43.989	50.009	50.025	0.046
	1.7323	1.9685	0.866	7100	13620	1.7323	1.7319	1.9689	1.9695	0.101				

Shaft Dia.	Dimensions mm/in.			Assembly Designation	Load Ratings		Limiting Speed		C _g	Mounting Dimensions mm/in.				Wt. kg/lbs.
	-0.2 - .008 -0.55 - .022				kN/lbf.		Grease	Oil		Max.	Min.	Min.	Max.	
	mm	F _w	E _w		B _c	C	C ₀	RPM		S	H			
	44	50	22.0	K44X50X22H	31.6	60.6	6400	9900	0.0523	44.000	43.989	50.009	50.025	0.046
	1.7323	1.9685	0.866		7100	13620				1.7323	1.7319	1.9689	1.9695	
	44	50	30.5	K44X50X30,5HZW	35.5	70.5	6400	9900	0.0543	44.000	43.989	50.009	50.025	0.068
	1.7323	1.9685	1.201		7980	15850				1.7323	1.7319	1.9689	1.9695	
45	45	50	13.0	K45X50X13H	18.4	35.1	6100	9400	0.0474	45.000	44.989	50.009	50.025	0.022
	1.7717	1.9685	0.512		4140	7890				1.7717	1.7712	1.9689	1.9695	
	45	50	15.0	K45X50X15FVB	19.4	37.3	6100	9400	0.0482	45.000	44.989	50.009	50.025	0.028
	1.7717	1.9685	0.591		4360	8390				1.7717	1.7712	1.9689	1.9695	
	45	50	17.0	K45X50X17H	24.9	51.8	6100	9400	0.0523	45.000	44.989	50.009	50.025	0.030
	1.7717	1.9685	0.669		5600	11650				1.7717	1.7712	1.9689	1.9695	
	45	50	20.0	K45X50X20F	27.0	57.4	6100	9400	0.0536	45.000	44.989	50.009	50.025	0.040
	1.7717	1.9685	0.787		6070	12900				1.7717	1.7712	1.9689	1.9695	
	45	50	21.0	K45X50X21CH	24.6	50.4	6100	9400	0.0519	45.000	44.989	50.009	50.025	0.036
	1.7717	1.9685	0.827		5530	11330				1.7717	1.7712	1.9689	1.9695	
	45	50	27.0	K45X50X27FH.ZB2	34.2	77.4	6100	9400	0.0577	45.000	44.989	50.009	50.025	0.043
	1.7717	1.9685	1.063		7690	17400				1.7717	1.7712	1.9689	1.9695	
	45	50	27.0	K45X50X27TN	31.8	70.7	6100	9400	—	45.000	44.989	50.009	50.025	0.048
	1.7717	1.9685	1.063		7150	15890				1.7717	1.7712	1.9689	1.9695	
	45	52	18.0	K45X52X18H	30.1	52.0	6200	9500	0.0497	45.000	44.989	52.010	52.029	0.045
	1.7717	2.0472	0.709		6770	11690				1.7717	1.7712	2.0476	2.0484	
	45	52	21.0	K45X52X21F	35.0	63.2	6200	9500	0.0521	45.000	44.989	52.010	52.029	0.055
	1.7717	2.0472	0.827		7870	14210				1.7717	1.7712	2.0476	2.0484	
	45	53	19.8	K45X53X20FH.ZB2	36.0	59.5	6200	9600	0.0504	45.000	44.989	53.010	53.029	0.060
	1.7717	2.0866	0.780		8090	13380				1.7717	1.7712	2.0870	2.0878	
	45	53	20.0	K45X53X20H	36.0	59.5	6200	9600	0.0504	45.000	44.989	53.010	53.029	0.054
	1.7717	2.0866	0.787		8090	13380				1.7717	1.7712	2.0870	2.0878	
	45	53	24.8	K45X53X25H	45.9	81.5	6200	9600	0.0545	45.000	44.989	53.010	53.029	0.072
	1.7717	2.0866	0.976		10320	18320				1.7717	1.7712	2.0870	2.0878	
	45	53	25.0	K45X53X25F	42.5	73.7	6200	9600	0.0531	45.000	44.989	53.010	53.029	0.075
	1.7717	2.0866	0.984		9550	16570				1.7717	1.7712	2.0870	2.0878	
	45	53	28.0	K45X53X28H	49.3	89.2	6200	9600	0.0557	45.000	44.989	53.010	53.029	0.078
	1.7717	2.0866	1.102		11080	20050				1.7717	1.7712	2.0870	2.0878	
	45	55	20.0	K45X55X20H	42.0	62.2	6400	9800	0.0494	45.000	44.989	55.010	55.029	0.074
	1.7717	2.1654	0.787		9440	13980				1.7717	1.7712	2.1657	2.1665	
	45	59	18.0	K45X59X18H	47.8	58.9	6600	10000	0.0467	45.000	44.989	59.010	59.029	0.107
	1.7717	2.3228	0.709		10750	13240				1.7717	1.7712	2.3232	2.3240	
	45	59	18.0	K45X59X18TN	45.7	55.4	6600	10000	—	45.000	44.989	59.010	59.029	0.097
	1.7717	2.3228	0.709		10270	12450				1.7717	1.7712	2.3232	2.3240	
	45	59	36.0	K45X59X36H	82.4	118	6600	10000	0.0555	45.000	44.989	59.010	59.029	0.181
	1.7717	2.3228	1.417		18520	26530				1.7717	1.7712	2.3232	2.3240	
	45	60	30.0	K45X60X30H	75.5	101	6600	10000	0.0530	45.000	44.989	60.010	60.029	0.171
	1.7717	2.3622	1.181		16970	22710				1.7717	1.7712	2.3626	2.3633	
	45	60	45.0	K45X60X45H	108	160	6600	10000	0.0594	45.000	44.989	60.010	60.029	0.280
	1.7717	2.3622	1.772		24280	35970				1.7717	1.7712	2.3626	2.3633	
46	46	53	36.0	K46X53X36HZW	48.6	96.7	6100	9300	0.0585	46.000	45.989	53.010	53.029	0.100
	1.8110	2.0866	1.417		10930	21740				1.8110	1.8106	2.0870	2.0878	0.220
47	47	52	15.0	K47X52X15FH	20.1	39.8	5800	8900	0.0499	47.000	46.989	52.010	52.029	0.030
	1.8504	2.0472	0.591		4520	8950				1.8504	1.8500	2.0476	2.0484	
	47	52	17.0	K47X52X17H	24.2	50.4	5800	8900	0.0529	47.000	46.989	52.010	52.029	0.032
	1.8504	2.0472	0.669		5440	11330				1.8504	1.8500	2.0476	2.0484	
	47	52	26.8	K47X52X27FH	35.4	82.4	5800	8900	0.0598	47.000	46.989	52.010	52.029	0.045
	1.8504	2.0472	1.055		7960	18520				1.8504	1.8500	2.0476	2.0484	
	47	52	27.0	K47X52X27H	36.6	85.9	5800	8900	0.0604	47.000	46.989	52.010	52.029	0.045
	1.8504	2.0472	1.063		8230	19310				1.8504	1.8500	2.0476	2.0484	
	47	55	28.0	K47X55X28FV1	48.9	89.5	6000	9200	0.0568	47.000	46.989	55.010	55.029	0.092
	1.8504	2.1654	1.102		10990	20120				1.8504	1.8500	2.1657	2.1665	
48	48	53	17.0	K48X53X17H	25.7	54.9	5700	8700	0.0546	48.000	47.989	53.010	53.029	0.032
	1.8898	2.0866	0.669		5780	12340				1.8898	1.8893	2.0870	2.0878	0.071

Continued on next page.



NEEDLE ROLLER BEARINGS

SINGLE-ROW, DOUBLE-ROW ASSEMBLIES — *continued*

METRIC SERIES

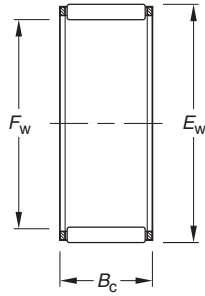

K

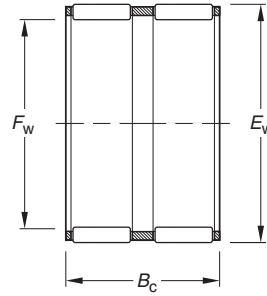

K.ZW

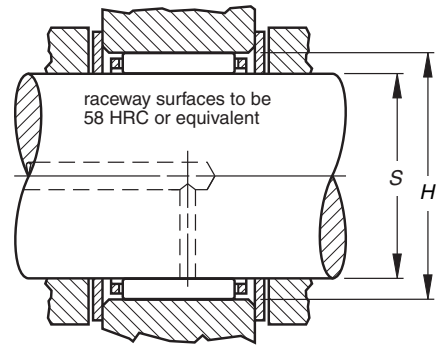

Shaft Dia.	Dimensions mm/in.			Assembly Designation	Load Ratings		Limiting Speed			Mounting Dimensions mm/in.				Wt. kg/lbs.
	-0.2 -0.08 -0.55 -0.22				C	Co	Grease	Oil		Max.	Min.	Min.	Max.	
mm	Fw	Ew	Bc				RPM	Cg	S		H			
48	48	54	19.0	K48X54X19H.ZB2	30.9	61.2	5700	8800	0.0545	48.000	47.989	54.010	54.029	0.042
	1.8898	2.1260	0.748		6950	13760				1.8898	1.8893	2.1264	2.1271	
49	49	55	32.0	K49X55X32HZW	40.2	86.4	5600	8600	0.0599	49.000	48.989	55.010	55.029	0.080
	1.9291	2.1654	1.260		9040	19420				1.9291	1.9287	2.1657	2.1665	
49	49	65	38.0	K49X65X38H	100	142	6100	9300	0.0593	49.000	48.989	65.010	65.029	0.244
	1.9291	2.5591	1.496		22480	31920				1.9291	1.9287	2.5594	2.5602	
50	50	55	17.0	K50X55X17H	25.5	55.0	5400	8400	0.0557	50.000	49.989	55.010	55.029	0.032
	1.9685	2.1654	0.669		5730	12360				1.9685	1.9681	2.1657	2.1665	
50	50	55	20.0	K50X55X20H	30.2	68.5	5400	8400	0.0588	50.000	49.989	55.010	55.029	0.038
	1.9685	2.1654	0.787		6790	15400				1.9685	1.9681	2.1657	2.1665	
50	50	55	30.0	K50X55X30	38.2	92.4	5400	8400	0.0633	50.000	49.989	55.010	55.029	0.057
	1.9685	2.1654	1.181		8590	20770				1.9685	1.9681	2.1657	2.1665	
50	50	55	30.0	K50X55X30FV1	38.2	92.4	5400	8400	0.0633	50.000	49.989	55.010	55.029	0.057
	1.9685	2.1654	1.181		8590	20770				1.9685	1.9681	2.1657	2.1665	
50	50	56	23.0	K50X56X23	35.5	74.1	5500	8500	0.0582	50.000	49.989	56.010	56.029	0.051
	1.9685	2.2047	0.906		7980	16660				1.9685	1.9681	2.2051	2.2059	
50	50	57	18.0	K50X57X18FH	31.3	56.4	5500	8500	0.0531	50.000	49.989	57.010	57.029	0.050
	1.9685	2.2441	0.709		7040	12680				1.9685	1.9681	2.2445	2.2452	
50	50	58	20.0	K50X58X20H	38.8	67.8	5600	8600	0.0545	50.000	49.989	58.010	58.029	0.065
	1.9685	2.2835	0.787		8720	15240				1.9685	1.9681	2.2839	2.2846	
50	50	58	25.0	K50X58X25H	46.5	85.6	5600	8600	0.0577	50.000	49.989	58.010	58.029	0.081
	1.9685	2.2835	0.984		10450	19240				1.9685	1.9681	2.2839	2.2846	
50	50	58	35.0	K50X58X35H	64.9	131	5600	8600	0.0642	50.000	49.989	58.010	58.029	0.105
	1.9685	2.2835	1.378		14590	29450				1.9685	1.9681	2.2839	2.2846	
50	50	62	30.0	K50X62X30H.ZB2	64.6	98.1	5800	8900	0.0565	50.000	49.989	62.010	62.029	0.136
	1.9685	2.4409	1.181		14520	22050				1.9685	1.9681	2.4413	2.4421	
50	50	66	30.0	K50X66X30H	80.9	109	5900	9100	0.0559	50.000	49.989	66.010	66.029	0.192
	1.9685	2.5984	1.181		18190	24500				1.9685	1.9681	2.5988	2.5996	
50	50	70	32.0	K50X70X32H	103	129	6100	9300	0.0569	50.000	49.989	70.010	70.029	0.224
	1.9685	2.7559	1.260		23160	29000				1.9685	1.9681	2.7563	2.7570	
52	52	57	12.0	K52X57X12	18.4	36.7	5200	8000	0.0512	52.000	51.987	57.010	57.029	0.022
	2.0472	2.2441	0.472		4140	8250				2.0472	2.0467	2.2445	2.2452	
52	52	57	17.0	K52X57X17FCH	21.4	44.3	5200	8000	0.0537	52.000	51.987	57.010	57.029	0.035
	2.0472	2.2441	0.669		4810	9960				2.0472	2.0467	2.2445	2.2452	
52	52	57	17.0	K52X57X17H	21.4	44.3	5200	8000	0.0537	52.000	51.987	57.010	57.029	0.035
	2.0472	2.2441	0.669		4810	9960				2.0472	2.0467	2.2445	2.2452	
52	52	60	24.0	K52X60X24	47.1	88.3	5400	8200	0.0592	52.000	51.987	60.010	60.029	0.078
	2.0472	2.3622	0.945		10600	19900				2.0472	2.0467	2.3626	2.3633	
55	55	60	17.0	K55X60X17	26.0	58.3	4900	7600	0.0590	55.000	54.987	60.010	60.029	0.037
	2.1654	2.3622	0.669		5850	13100				2.1654	2.1648	2.3626	2.3633	
55	55	60	20.0	K55X60X20H	30.7	72.4	4900	7600	0.0622	55.000	54.987	60.010	60.029	0.042
	2.1654	2.3622	0.787		6900	16300				2.1654	2.1648	2.3626	2.3633	
55	55	60	27.0	K55X60X27H	40.1	102	4900	7600	0.0677	55.000	54.987	60.010	60.029	0.055
	2.1654	2.3622	1.063		9010	22900				2.1654	2.1648	2.3626	2.3633	
55	55	60	30.0	K55X60X30	40.6	103	4900	7600	0.0680	55.000	54.987	60.010	60.029	0.066
	2.1654	2.3622	1.181		9130	23200				2.1654	2.1648	2.3626	2.3633	

Shaft Dia.	Dimensions mm/in.			Assembly Designation	Load Ratings		Limiting Speed		C _g	Mounting Dimensions mm/in.				Wt. kg/lbs.
	-0.2 - .008 -0.55 - .022				kN/lbf.		Grease	Oil		Max.	Min.	Min.	Max.	
	mm	F _w	E _w		B _c	C	C ₀	RPM		S	H			
	55	60	30.0	K55X60X30FH	40.6	103	4900	7600	0.0680	55.000	54.987	60.010	60.029	0.068 0.150
	2.1654	2.3622	1.181		9130	23200				2.1654	2.1648	2.3626	2.3633	
	55	61	26.0	K55X61X26H	44.3	102	5000	7600	0.0657	55.000	54.987	61.010	61.029	0.063 0.139
	2.1654	2.4016	1.024		9960	22900				2.1654	2.1648	2.4020	2.4027	
	55	62	18.0	K55X62X18H	33.2	62.8	5000	7700	0.0569	55.000	54.987	62.010	62.029	0.055 0.121
	2.1654	2.4409	0.709		7460	14100				2.1654	2.1648	2.4413	2.4421	
	55	63	15.0	K55X63X15F	30.5	51.5	5000	7800	0.0531	55.000	54.987	63.010	63.029	0.054 0.119
	2.1654	2.4803	0.591		6860	11600				2.1654	2.1648	2.4807	2.4815	
	55	63	20.0	K55X63X20	40.3	73.5	5000	7800	0.0580	55.000	54.987	63.010	63.029	0.072 0.159
	2.1654	2.4803	0.787		9060	16500				2.1654	2.1648	2.4807	2.4815	
	55	63	25.0	K55X63X25	49.8	96.5	5000	7800	0.0621	55.000	54.987	63.010	63.029	0.080 0.176
	2.1654	2.4803	0.984		11200	21700				2.1654	2.1648	2.4807	2.4815	
	55	63	32.0	K55X63X32	62.3	129	5000	7800	0.0667	55.000	54.987	63.010	63.029	0.108 0.238
	2.1654	2.4803	1.260		14000	29000				2.1654	2.1648	2.4807	2.4815	
58	58	63	17.0	K58X63X17F	27.0	62.6	4700	7200	0.0615	58.000	57.987	63.010	63.029	0.037 0.082
	2.2835	2.4803	0.669		6070	14100				2.2835	2.2830	2.4807	2.4815	
	58	64	19.0	K58X64X19H	32.9	70.6	4700	7200	0.0615	58.000	57.987	64.010	64.029	0.037 0.082
	2.2835	2.5197	0.748		7400	15900				2.2835	2.2830	2.5201	2.5208	
	58	65	18.0	K58X65X18H	34.3	67.1	4700	7300	0.0593	58.000	57.987	65.010	65.029	0.058 0.128
	2.2835	2.5591	0.709		7710	15100				2.2835	2.2830	2.5594	2.5602	
60	60	65	20.0	K60X65X20H	31.9	78.1	4500	6900	0.0660	60.000	59.987	65.010	65.029	0.046 0.101
	2.3622	2.5591	0.787		7170	17600				2.3622	2.3617	2.5594	2.5602	
	60	65	26.8	K60X65X27FH	39.5	103	4500	6900	0.0707	60.000	59.987	65.010	65.029	0.059 0.130
	2.3622	2.5591	1.055		8880	23200				2.3622	2.3617	2.5594	2.5602	
	60	65	29.8	K60X65X30FH	42.9	114	4500	6900	0.0726	60.000	59.987	65.010	65.029	0.085 0.187
	2.3622	2.5591	1.173		9640	25600				2.3622	2.3617	2.5594	2.5602	
	60	65	30.0	K60X65X30	42.9	114	4500	6900	0.0726	60.000	59.987	65.010	65.029	0.070 0.154
	2.3622	2.5591	1.181		9640	25600				2.3622	2.3617	2.5594	2.5602	
	60	68	17.0	K60X68X17F	34.2	61.4	4600	7100	0.0577	60.000	59.987	68.010	68.029	0.066 0.146
	2.3622	2.6772	0.669		7690	13800				2.3622	2.3617	2.6776	2.6783	
	60	68	20.0	K60X68X20H	41.8	79.2	4600	7100	0.0614	60.000	59.987	68.010	68.029	0.066 0.146
	2.3622	2.6772	0.787		9400	17800				2.3622	2.3617	2.6776	2.6783	
	60	68	23.0	K60X68X23F	49.0	97.2	4600	7100	0.0646	60.000	59.987	68.010	68.029	0.089 0.196
	2.3622	2.6772	0.906		11000	21900				2.3622	2.3617	2.6776	2.6783	
	60	68	23.0	K60X68X23FH	49.0	97.2	4600	7100	0.0646	60.000	59.987	68.010	68.029	0.089 0.196
	2.3622	2.6772	0.906		11000	21900				2.3622	2.3617	2.6776	2.6783	
	60	68	23.0	K60X68X23H	49.0	97.2	4600	7100	0.0646	60.000	59.987	68.010	68.029	0.089 0.196
	2.3622	2.6772	0.906		11000	21900				2.3622	2.3617	2.6776	2.6783	
	60	68	25.0	K60X68X25	51.6	104	4600	7100	0.0657	60.000	59.987	68.010	68.029	0.091 0.201
	2.3622	2.6772	0.984		11600	23400				2.3622	2.3617	2.6776	2.6783	
	60	68	30.0	K60X68X30ZW	46.4	90.1	4600	7100	0.0634	60.000	59.987	68.010	68.029	0.119 0.262
	2.3622	2.6772	1.181		10400	20300				2.3622	2.3617	2.6776	2.6783	
63	63	71	20.0	K63X71X20	41.4	79.4	4400	6700	0.0628	63.000	62.987	71.010	71.029	0.070 0.154
	2.4803	2.7953	0.787		9310	17800				2.4803	2.4798	2.7957	2.7964	
64	64	70	16.0	K64X70X16	26.4	55.1	4200	6500	0.0605	64.000	63.987	70.010	70.029	0.049 0.108
	2.5197	2.7559	0.630		5930	12400				2.5197	2.5192	2.7563	2.7570	
65	65	70	20.0	K65X70X20CH	28.6	69.2	4100	6400	0.0665	65.000	64.987	70.010	70.029	0.050 0.110
	2.5591	2.7559	0.787		6430	15600				2.5591	2.5585	2.7563	2.7570	
	65	70	20.0	K65X70X20F	31.5	78.9	4100	6400	0.0687	65.000	64.987	70.010	70.029	0.050 0.110
	2.5591	2.7559	0.787		7080	17700				2.5591	2.5585	2.7563	2.7570	
	65	70	20.0	K65X70X20H	31.5	78.9	4100	6400	0.0687	65.000	64.987	70.010	70.029	0.050 0.110
	2.5591	2.7559	0.787		7080	17700				2.5591	2.5585	2.7563	2.7570	
	65	70	30.0	K65X70X30	44.4	123	4100	6400	0.0766	65.000	64.987	70.010	70.029	0.075 0.165
	2.5591	2.7559	1.181		9980	27700				2.5591	2.5585	2.7563	2.7570	
	65	73	23.0	K65X73X23H	48.2	97.7	4200	6500	0.0671	65.000	64.987	73.010	73.029	0.091 0.201
	2.5591	2.8740	0.906		10800	22000				2.5591	2.5585	2.8744	2.8752	
	65	73	30.0	K65X73X30H	60.1	129	4200	6500	0.0719	65.000	64.987	73.010	73.029	0.116 0.256
	2.5591	2.8740	1.181		13500	29100				2.5591	2.5585	2.8744	2.8752	

Continued on next page.



NEEDLE ROLLER BEARINGS

SINGLE-ROW, DOUBLE-ROW ASSEMBLIES — *continued*

METRIC SERIES

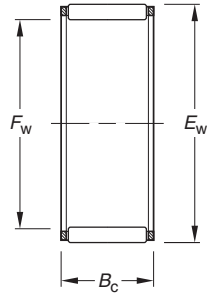

K

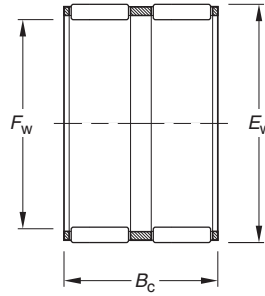

K.ZW

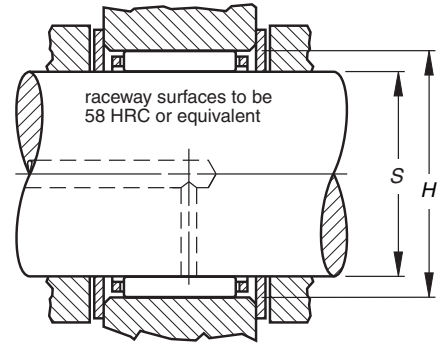

Shaft Dia.	Dimensions mm/in.			Assembly Designation	Load Ratings		Limiting Speed			Mounting Dimensions mm/in.				Wt. kg/lbs.	
	-0.2 -0.008 -0.55 -0.022				kN/lbf.		Grease	Oil	C ₉		Max.	Min.	Min.		Max.
	mm	F _w	E _w		B _c	C	C ₀	RPM		S		H			
68	68	74	20.0	K68X74X20FH	37.5	88.1	4000	6100	0.0699	68.000	67.987	74.010	74.029	0.062	
	2.6772	2.9134	0.787		8430	19800				2.6772	2.6767	2.9138	2.9145		0.137
68	68	74	28.0	K68X74X28CH	44.8	110	4000	6100	0.0739	68.000	67.987	74.010	74.029	0.082	
	2.6772	2.9134	1.102		10100	24700				2.6772	2.6767	2.9138	2.9145		0.181
68	68	74	30.0	K68X74X30H	47.6	119	4000	6100	0.0754	68.000	67.987	74.010	74.029	0.098	
	2.6772	2.9134	1.181		10700	26800				2.6772	2.6767	2.9138	2.9145		0.216
68	68	74	35.0	K68X74X35HZW	45.1	111	4000	6100	0.0740	68.000	67.987	74.010	74.029	0.120	
	2.6772	2.9134	1.378		10100	25000				2.6772	2.6767	2.9138	2.9145		0.265
68	68	76	20.0	K68X76X20	43.8	87.8	4000	6200	0.0667	68.000	67.987	76.010	76.029	0.086	
	2.6772	2.9921	0.787		9850	19700				2.6772	2.6767	2.9925	2.9933		0.190
68	68	82	38.5	K68X82X38,5H	117	209	4200	6400	0.0761	68.000	67.987	82.012	82.034	0.320	
	2.6772	3.2283	1.516		26300	47000				2.6772	2.6767	3.2288	3.2297		0.705
70	70	76	20.0	K70X76X20	36.1	84.7	3900	5900	0.0702	70.000	69.987	76.010	76.029	0.065	
	2.7559	2.9921	0.787		8120	19000				2.7559	2.7554	2.9925	2.9933		0.143
70	70	76	30.0	K70X76X30	51.6	134.0	3900	5900	0.0786	70.000	69.987	76.010	76.029	0.097	
	2.7559	2.9921	1.181		11600	30100				2.7559	2.7554	2.9925	2.9933		0.214
70	70	78	20.0	K70X78X20H	43.6	87.9	3900	6000	0.0676	70.000	69.987	78.010	78.029	0.090	
	2.7559	3.0709	0.787		9800	19800				2.7559	2.7554	3.0713	3.0720		0.198
70	70	78	23.0	K70X78X23F	49.8	104.0	3900	6000	0.0705	70.000	69.987	78.010	78.029	0.115	
	2.7559	3.0709	0.906		11200	23400				2.7559	2.7554	3.0713	3.0720		0.254
70	70	78	24.8	K70X78X25F	49.8	104.0	3900	6000	0.0705	70.000	69.987	78.010	78.029	0.115	
	2.7559	3.0709	0.976		11200	23400				2.7559	2.7554	3.0713	3.0720		0.254
70	70	78	30.0	K70X78X30H	62.2	139.0	3900	6000	0.0757	70.000	69.987	78.010	78.029	0.140	
	2.7559	3.0709	1.181		14000	31200				2.7559	2.7554	3.0713	3.0720		0.309
70	70	78	46.0	K70X78X46ZW	78.4	187.0	3900	6000	0.0815	70.000	69.987	78.010	78.029	0.188	
	2.7559	3.0709	1.811		17600	42000				2.7559	2.7554	3.0713	3.0720		0.414
70	70	85	40.0	K70X85X40F	118	203	4100	6300	0.0758	70.000	69.987	85.012	85.034	0.338	
	2.7559	3.3465	1.575		26500	45600				2.7559	2.7554	3.3469	3.3478		0.745
70	70	88	30.0	K70X88X30H.ZB2	115	175	4100	6400	0.0714	70.000	69.987	88.012	88.034	0.205	
	2.7559	3.4646	1.181		25900	39300				2.7559	2.7554	3.4650	3.4659		0.452
72	72	80	20.0	K72X80X20	44.4	90.7	3800	5800	0.0690	72.000	71.987	80.010	80.029	0.084	
	2.8346	3.1496	0.787		9980	20400				2.8346	2.8341	3.1500	3.1507		0.185
73	73	79	20.0	K73X79X20	37.0	88.7	3700	5700	0.0723	73.000	72.987	79.010	79.029	0.068	
	2.8740	3.1102	0.787		8320	19900				2.8740	2.8735	3.1106	3.1114		0.150
75	75	81	20.0	K75X81X20F	37.4	90.7	3600	5500	0.0737	75.000	74.987	81.012	81.034	0.075	
	2.9528	3.1890	0.787		8410	20400				2.9528	2.9522	3.1894	3.1903		0.165
75	75	83	23.0	K75X83X23	52.5	114.0	3600	5600	0.0744	75.000	74.987	83.012	83.034	0.104	
	2.9528	3.2677	0.906		11800	25600				2.9528	2.9522	3.2682	3.2691		0.229
75	75	83	30.0	K75X83X30	60.9	138	3600	5600	0.0780	75.000	74.987	83.012	83.034	0.141	
	2.9528	3.2677	1.181		13700	31000				2.9528	2.9522	3.2682	3.2691		0.311
75	75	83	30.0	K75X83X30FH	60.9	138	3600	5600	0.0780	75.000	74.987	83.012	83.034	0.141	
	2.9528	3.2677	1.181		13700	31000				2.9528	2.9522	3.2682	3.2691		0.311
80	80	86	20.0	K80X86X20H	38.6	96.7	3400	5200	0.0771	80.000	79.987	86.012	86.034	0.072	
	3.1496	3.3858	0.787		8680	21700				3.1496	3.1491	3.3863	3.3872		0.159
80	80	88	25.0	K80X88X25FV1	54.0	121	3400	5200	0.0778	80.000	79.987	88.012	88.034	0.134	
	3.1496	3.4646	0.984		12100	27200				3.1496	3.1491	3.4650	3.4659		0.295

Shaft Dia.	Dimensions mm/in.			Assembly Designation	Load Ratings kN/lbf.		Limiting Speed		C _g	Mounting Dimensions mm/in.				Wt. kg/lbs.
	-0.2 - .008 -0.55 - .022				C	C ₀	Grease	Oil		Max.	Min.	Min.	Max.	
mm	F _w	E _w	B _c				RPM		S	H				
80	80	88	30.0	K80X88X30	67.5	161	3400	5200	0.0835	80.000	79.987	88.012	88.034	0.153
	3.1496	3.4646	1.181		15200	36200				3.1496	3.1491	3.4650	3.4659	
85	85	92	20.0	K85X92X20H	39.9	91.7	3200	4900	0.0763	84.988	84.973	92.012	92.034	0.085
	3.3465	3.6220	0.787		8970	20600				3.3460	3.3454	3.6225	3.6234	
85	85	93	25.0	K85X93X25F						84.988	84.973	93.012	93.034	0.000
	3.3465	3.6614	0.984							3.3460	3.3454	3.6619	3.6628	
85	85	93	30.0	K85X93X30H	69.4	170	3200	4900	0.0870	84.988	84.973	93.012	93.034	0.166
	3.3465	3.6614	1.181		15600	38200				3.3460	3.3454	3.6619	3.6628	
90	90	97	20.0	K90X97X20	46.3	114	3000	4600	0.0827	89.988	89.973	97.012	97.034	0.095
	3.5433	3.8189	0.787		10400	25600				3.5428	3.5422	3.8194	3.8202	
90	90	98	25.0	K90X98X25F	54.8	128	3000	4600	0.0832	89.988	89.973	98.012	98.034	0.134
	3.5433	3.8583	0.984		12300	28800				3.5428	3.5422	3.8587	3.8596	
90	90	98	30.0	K90X98X30	63.6	155	3000	4600	0.0873	89.988	89.973	98.012	98.034	0.168
	3.5433	3.8583	1.181		14300	34800				3.5428	3.5422	3.8587	3.8596	
95	95	103	20.0	K95X103X20	49.3	114	2800	4400	0.0829	94.988	94.973	103.012	103.034	0.130
	3.7402	4.0551	0.787		11100	25600				3.7397	3.7391	4.0556	4.0565	
95	95	103	30.0	K95X103X30F	71.0	183	2800	4400	0.0932	94.988	94.973	103.012	103.034	0.180
	3.7402	4.0551	1.181		16000	41100				3.7397	3.7391	4.0556	4.0565	
100	100	108	30.0	K100X108X30	72.4	191	2700	4200	0.0965	99.988	99.973	108.012	108.034	0.210
	3.9370	4.2520	1.181		16300	42900				3.9365	3.9359	4.2524	4.2533	
110	110	118	24.0	K110X118X24	64.0	168	2400	3800	0.0977	109.988	109.973	118.012	118.034	0.165
	4.3307	4.6457	0.945		14400	37800				4.3302	4.3296	4.6461	4.6470	
110	110	118	30.0	K110X118X30H	75.3	207	2400	3800	0.1029	109.988	109.973	118.012	118.034	0.200
	4.3307	4.6457	1.181		16900	46500				4.3302	4.3296	4.6461	4.6470	





NEEDLE ROLLER AND CAGE RADIAL ASSEMBLIES FOR CONNECTING ROD APPLICATIONS – METRIC SERIES

Connecting rods have two bearing positions: the crank pin or big end and the wrist pin or small end.

In the crank pin position there may be severe operating conditions due to centrifugal forces, internal forces, accelerations and high rotational speeds, requiring the use of special needle roller and cage radial assemblies.

Similarly, in the wrist pin position the reciprocating inertia loads and high oscillating speeds dictate the use of special cage designs.

Types Of Metric Series Needle Roller and Cage Radial Assemblies.

Needle roller and cage assembly for crank pin applications.

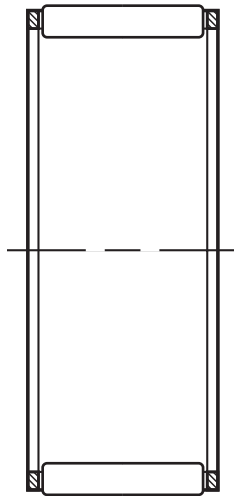

K.BE

Needle roller and cage assembly for wrist pin applications.

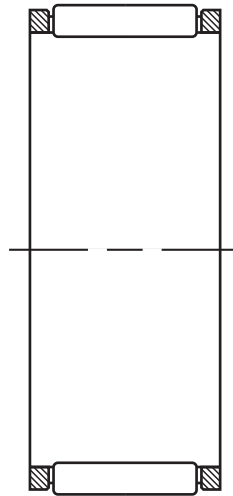

K.SE

Suffixes

BE	steel cage, heat treated, for crank pin position
SE	steel cage, heat treated, for wrist pin position

C



CONSTRUCTION

METRIC SERIES NEEDLE ROLLER AND CAGE RADIAL ASSEMBLIES FOR CRANK PIN POSITIONS

Needle roller and cage assemblies for use in crank pin positions have cages with a large outside cylindrical surface to ensure optimum radial guidance in the connecting rod bore. Due to the inherent low weight and strength of the heat-treated cages, the needle roller and cage assemblies are well-suited for high engine speed applications. When necessary, silver plating and copper plating can be applied for optimum performance during operation at high speeds.

METRIC SERIES NEEDLE ROLLER AND CAGE RADIAL ASSEMBLIES FOR WRIST PIN POSITIONS

Reciprocating inertia loads and oscillating speeds require the cages used in the wrist pin positions to be heat treated and to guide on the wrist pin.

These cages are available in a variety of widths to allow the selection of a needle roller and cage assembly with the length of needle rollers to match the connecting rod width.

SIZE SELECTION

In most instances selection of a suitable size of a needle roller and cage assembly for typical connecting rod positions may be based on the cylinder displacement of the engine which in turn, dictates the crank pin and wrist pin diameters.

Suggestions based on engine displacements are listed in the following table.

TABLE 1 – CRANK PIN AND WRIST PIN DIAMETERS, DETERMINED BY THE CYLINDER DISPLACEMENT OF THE ENGINE.

		CYLINDER DISPLACEMENT IN CM ³						
Cylinder	>		40	60	100	150	200	300
Displacement	≤	40	60	100	150	200	300	

		DIAMETER IN MM						
Crank pin		12/14	15/16/18	18/20	18/20/22	24/25/28	28/30	35/40
Wrist pin		10/11	12/13	14/15	15/16	18	20	20





CONNECTING ROD GUIDANCE ARRANGEMENTS

End guidance of a connecting rod can be provided either at the crank pin or at the wrist pin end. Connecting rod guidance is achieved at the crank pin end using a small clearance between the crank webs. Guidance at the wrist pin end is controlled by a small clearance between the piston bosses.

CRANK PIN END GUIDANCE

With crank pin end guidance care must be taken that an adequate amount of lubricant is supplied to the crank pin bearing and the surfaces which guide the connecting rod. For this purpose, grooves in the connecting rod end faces or slots in the connecting rod bore aligned with the incoming lubrication path should be provided. Occasionally, bronze or hardened steel washers may be used for end guidance of the connecting rod.

At the wrist pin end, the needle roller and cage assembly is located axially between the piston bosses. It may be both economical and effective to machine the connecting rod at the wrist pin end and at the crank pin end to the same width. It is suggested that at the wrist pin end the needle roller length does not overhang the connecting rod width. Otherwise, the load rating of the needle roller and cage assembly will be reduced.

WRIST PIN END GUIDANCE

Wrist pin end will get the most effective axial guidance between the piston bosses. Grooves in the bottom of the piston bosses and a chamfer of small angle on each side of the upper portion of the connecting rod small end, can improve the oil flow to the needle roller and cage assembly and its guiding surfaces.

The length of the needle roller and cage assembly and the connecting rod width at the crank pin end should be identical to ensure best possible radial piloting of cage in the bore of the connecting rod. The crank webs are recessed to allow proper axial alignment of the connecting rod. As a rule, it is not necessary to have additional supply of lubricant. Only in engines with sparse lubrication should consideration be given to provide lubricating slots in the connecting rod bores as with crank pin end guidance.

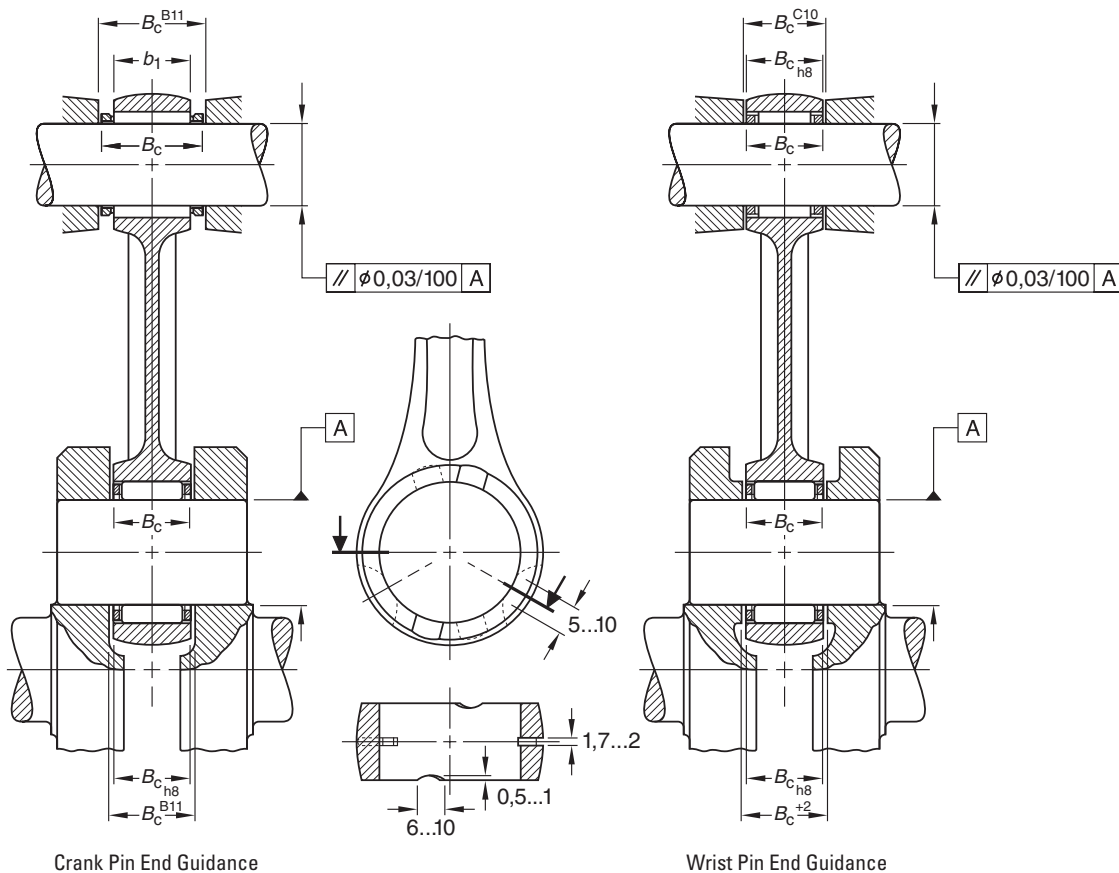

Suitable Materials and Heat Treatment

Connecting rod crank pin end and wrist pin end bores serve as raceways:

a case hardening steel such as 15 CrNi 6, 17 MnCr 5 or AISI 8620.

Crank pins:

e.g., case hardening steel 15 Cr 3, AISI 8620, AISI 1018 or through-hardening steel 100 Cr 6, AISI 52100.

Wrist pins:

e.g., case hardening steel Ck 15, 15 Cr 3 or through-hardening steel 100 Cr 6, AISI 52100.

The effective case depth (50 HRC) of the raceways should be 0.5 mm minimum, the surface hardness should be 60 HRC or 700 HV minimum.

After hardening, the connecting rods must be stress relieved.

The connecting rod raceway bores as well as the crank pins and the wrist pins must be precision ground or preferably honed to a surface finish R_a not exceeding 0.16 μm .

FORM TOLERANCES

The form tolerances for crank pins, wrist pins and connecting rod bores are listed in Table 2.

TABLE 2 – FORM TOLERANCES

		Dimension in mm				
Nominal pin diameter	>	10	14	18	25	30
	≤	14	18	25	30	40
		Tolerances in μm				
Parallelism*	wrist pin & crank pin	1	1	2	2	3
	rod bore	2	3	3	4	4
Circularity (DIN ISO 1101)	wrist pin & crank pin	1	1	1.5	1.5	2
	rod bore	1.5	2	2	2.5	2.5

* The parallelism values are valid for the needle roller length L_w .

It is suggested that the parallelism of the wrist pin axis and the crank pin axis be within a tolerance zone of 0.03 mm diameter over a distance of 100 mm.

RADIAL CLEARANCE

METRIC SERIES CRANK PIN BEARINGS

The high speeds of modern production engines dictate the need for crank pin bearings with a relatively large radial clearance. As an approximation, the minimum clearance can be taken as the crank pin diameter/1000. The maximum radial clearance would be a result of the sorting plan shown in Table 3.

As shown in the example of the matching scheme, the suggested mounting diameters for the crank pin position are G6 for the connecting rod bore diameters and h5 for the crank pin diameters. Axial location of the cage is shown on the crank pin end guidance arrangement.

Racing and sport engines operate at yet even higher speeds than production engines, requiring 50 percent larger radial clearances in the crank pin bearings. The larger radial clearances should also be used in bores of split connecting rods to avoid the danger of distortion resulting from the unavoidable connecting rod deformation occurring in operation. Consult your Timken representative for advice on such applications.

METRIC SERIES WRIST PIN BEARINGS

The radial clearance in wrist pin bearings should be held as small as possible. The minimum clearance should be aimed at 2 mm with the maximum clearance resulting from the proposed sorting plan in Table 3. The maximum clearance should be held as close as possible to 12 mm for all wrist pin bearings based on sorting wrist pins made to a tolerance h5, small end bore diameter tolerance of K6 and needle roller grades as shown in Table 3.



TIMKEN® TORRINGTON® METRIC SERIES NEEDLE ROLLER AND CAGE RADIAL ASSEMBLIES FOR CONNECTING ROD APPLICATIONS

TABLE 3 – RADIAL CLEARANCE

Matching Scheme For A Crank Pin Bearing Arrangement

(three diameter ranges are specified for the connecting rod and crank pin)

Example: Crank pin diameter 20 mm, tolerance h5
 Connecting rod bore diameter 26 mm, tolerance G6
 Needle roller and cage assembly K20x26x12BE
 Radial clearance 20 . . . 29 µm

		Connecting Rod Crank Pin End Bore Diameter 26 ⁺²⁰ / ₊₇ Tolerances and Radial Clearances In µm											
		+12 +7 Needle Roller Tolerance		Radial Clearance		+16 +12 Needle Roller Tolerance		Radial Clearance		+20 +16 Needle Roller Tolerance		Radial Clearance	
Crank Pin Diameter	0	-7		21...29		-4	-5	20...29		-2	-3	20...29	
	-3	-9				-6	-7			-4	-5		
	-3	-5		20...28		-3		21...28		-1		21...28	
	-6	-7				-5				-3			
20 ⁰ / ₋₉	-6	-4		21...29		-1	-2	20...29		0		22...29	
	-9	-6				-3	-4			-2			

Matching Scheme For A Wrist Pin Bearing Arrangement

(three diameter ranges are specified for the connecting rod and wrist pin)

Example: Wrist pin diameter 16 mm, tolerance h5
 Connecting rod bore diameter 20 mm, tolerance K6
 Needle roller and cage assembly K16x20x20SE
 Radial clearance 2 . . . 12 µm

		Wrist Pin End Bore Diameter 20 ⁺² / ₋₁₁ Tolerances and Radial Clearances In µm											
		-6 -11 Needle roller Tolerance		Radial Clearance		-2 -6 Needle Roller Tolerance		Radial Clearance		+2 -2 Needle Roller Tolerance		Radial Clearance	
Wrist Pin Diameter	0					-4	-5	2...11		-2	-3	2...11	
	-3					-6	-7			-4	-5		
	-3	-5		2...10		-3	-4	3...12		-1	-2	3...12	
16 ⁰ / ₋₈	-6	-7				-5	-6			-3	-4		
	-6	-4	-5	3...12		-1	-2	2...10		0		4...10	
	-8	-6	-7			-3	-4			-2			

**ASSEMBLIES FOR CRANK PIN
END APPLICATIONS
METRIC SERIES**

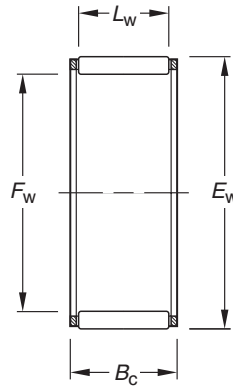

K.BE

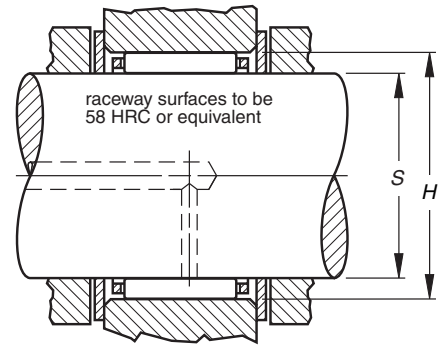

Shaft Dia.	Dimensions mm/in. -0.2 - .008 -0.55 - .022				Assembly Designation	Load Ratings kN/lbf.			Mounting Dimensions mm/in. (non-high performance engines)				Wt. kg/lbs.
	mm	F _w	E _w	B _c		L _w	C	C ₀	C _g	S	H	Max.	
12	12	12	16	10	K12X16X10BE	6.21	6.70	n/a	12.000	11.992	16.006	16.017	0.004
	0.4724	0.4724	0.6299	0.394		1400	1510		0.4724	0.4721	0.6302	0.6306	
12	12	17	10	7.8	K12X17X10BE	7.32	7.21	n/a	12.000	11.992	17.006	17.017	0.005
	0.4724	0.6693	0.394	0.307		1650	1620		0.4724	0.4721	0.6695	0.6700	
14	14	18	10	7.8	K14X18X10BE	6.89	7.98	n/a	14.000	13.992	18.006	18.017	0.005
	0.5512	0.7087	0.394	0.307		1550	1790		0.5512	0.5509	0.7089	0.7093	
14	14	18	10	7.8	WK14X18X10BE	6.89	7.98	0.0204	14.000	13.992	18.006	18.017	0.005
	0.5512	0.7087	0.394	0.307		1550	1790		0.5512	0.5509	0.7089	0.7093	
14	14	20	10	7.8	K14X20X10BE	8.90	8.61	0.0198	14.000	13.992	20.007	20.020	0.007
	0.5512	0.7874	0.394	0.307		2000	1940		0.5512	0.5509	0.7877	0.7882	
14	14	20	12	9.5	K14X20X12BE	10.50	10.60	0.0209	14.000	13.992	20.007	20.020	0.009
	0.5512	0.7874	0.472	0.374		2360	2380		0.5512	0.5509	0.7877	0.7882	
14	14	20	12	9.5	WK14X20X12BE	10.50	10.60	0.0209	14.000	13.992	20.007	20.020	0.009
	0.5512	0.7874	0.472	0.374		2360	2380		0.5512	0.5509	0.7877	0.7882	
15	15	22	12	9.0	K15,2X22,2X12BE	10.80	10.30	0.0211	15.200	15.192	22.207	22.220	0.012
	0.5984	0.8740	0.472	0.354		2430	2320		0.5984	0.5981	0.8743	0.8748	
16	16	21	10	7.8	K16X21X10BE	8.17	8.90	0.0215	16.000	15.992	21.007	21.020	0.007
	0.6299	0.8268	0.394	0.307		1840	2000		0.6299	0.6296	0.8270	0.8276	
16	16	21	10	7.8	WK16X21X10BE	8.17	8.90	0.0215	16.000	15.992	21.007	21.020	0.007
	0.6299	0.8268	0.394	0.307		1840	2000		0.6299	0.6296	0.8270	0.8276	
16	16	22	12	9.5	K16X22X12BE	11.20	11.90	0.0227	16.000	15.992	22.007	22.020	0.011
	0.6299	0.8661	0.472	0.374		2520	2680		0.6299	0.6296	0.8664	0.8669	
18	18	24	12	9.5	K18X24X12BE	11.80	13.10	0.0243	18.000	17.992	24.007	24.020	0.011
	0.7087	0.9449	0.472	0.374		2650	2940		0.7087	0.7083	0.9452	0.9457	
18	18	24	13	9.8	K18X24X13BE	12.10	13.50	0.0245	18.000	17.992	24.007	24.020	0.013
	0.7087	0.9449	0.512	0.386		2720	3030		0.7087	0.7083	0.9452	0.9457	
18	18	24	13	10.5	WK18X24X13BE	12.80	14.60	0.0250	18.000	17.992	24.007	24.020	0.011
	0.7087	0.9449	0.512	0.413		2880	3280		0.7087	0.7083	0.9452	0.9457	
18	18	24	15	11.8	K18X24X15BE	13.30	15.20	0.0253	18.000	17.992	24.007	24.020	0.014
	0.7087	0.9449	0.591	0.465		2990	3420		0.7087	0.7083	0.9452	0.9457	
19	19	25	15	12.5	K19X25X15BE	14.70	17.60	0.0268	19.000	18.991	25.007	25.020	0.014
	0.7480	0.9843	0.591	0.492		3300	3960		0.7480	0.7477	0.9845	0.9850	
20	20	26	12	9.8	K20X26X12BE	13.30	15.80	0.0267	20.000	19.991	26.007	26.020	0.013
	0.7874	1.0236	0.472	0.386		2990	3550		0.7874	0.7870	1.0239	1.0244	
20	20	26	17	13.8	K20X26X17BE	14.90	18.20	0.0276	20.000	19.991	26.007	26.020	0.017
	0.7874	1.0236	0.669	0.543		3350	4090		0.7874	0.7870	1.0239	1.0244	
21	21	27	13	10.5	K21,1X27,1X13BE	14.10	17.20	0.0278	21.100	21.091	27.107	27.120	0.016
	0.8307	1.0669	0.512	0.413		3170	3870		0.8307	0.8304	1.0672	1.0677	
22	22	28	13	9.8	K22X28X13BE	13.90	17.10	0.0283	22.000	21.991	28.007	28.020	0.015
	0.8661	1.1024	0.512	0.386		3120	3840		0.8661	0.8658	1.1026	1.1031	
22	22	29	15.6	12.8	WK22X29X15,6BE	18.50	22.30	0.0296	22.000	21.991	29.007	29.020	0.021
	0.8661	1.1417	0.614	0.504		4160	5010		0.8661	0.8658	1.1420	1.1425	
22	22	29	16	12.8	K22X29X16BE	18.50	22.30	0.0296	22.000	21.991	29.007	29.020	0.021
	0.8661	1.1417	0.630	0.504		4160	5010		0.8661	0.8658	1.1420	1.1425	

Continued on next page.



NEEDLE ROLLER BEARINGS

ASSEMBLIES FOR CRANK PIN END APPLICATIONS

continued

METRIC SERIES

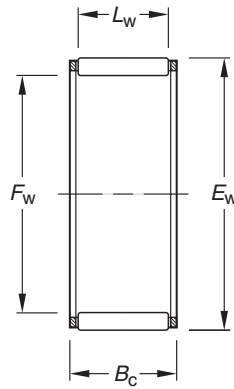

K.BE

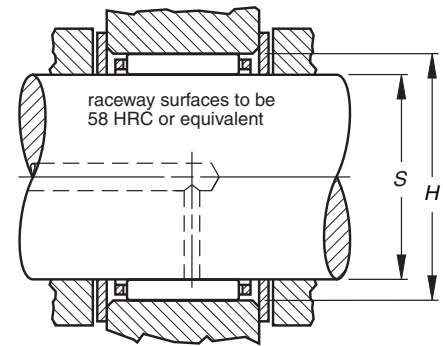

Shaft Dia.	Dimensions mm/in.				Assembly Designation	Load Ratings kN/lbf.			Mounting Dimensions mm/in. (non-high performance engines)				Wt. kg/lbs.
	F _w	E _w	B _c	L _w		C	C ₀	C _g	Max.	Min.	Min.	Max.	
mm									S	H			
24	24	30	13	9.8	K24X30X13BE	14.40	18.40	0.0298	24.000	23.991	30.007	30.020	0.016
	0.9449	1.1811	0.512	0.386		3240	4140		0.9449	0.9445	1.1814	1.1819	
24	24	30	15	11.8	K24X30X15BE	15.30	19.70	0.0304	24.000	23.991	30.007	30.020	0.018
	0.9449	1.1811	0.591	0.465		3440	4430		0.9449	0.9445	1.1814	1.1819	
24	24	30	17	13.8	K24X30X17BE	19.00	26.30	0.0326	24.000	23.991	30.007	30.020	0.021
	0.9449	1.1811	0.669	0.543		4270	5910		0.9449	0.9445	1.1814	1.1819	
25	25	31	19.8	17.8	WK25X31X20BE	23.30	34.50	0.0355	25.000	24.991	31.009	31.025	0.024
	0.9843	1.2205	0.780	0.701		5240	7760		0.9843	0.9839	1.2208	1.2215	
25	25	32	16	12.8	K25X32X16BE	19.20	24.30	0.0319	25.000	24.991	32.009	32.025	0.022
	0.9843	1.2598	0.630	0.504		4320	5460		0.9843	0.9839	1.2602	1.2608	
25	25	32	24	19.8	K25X32X24BE	27.50	38.50	0.0358	25.000	24.991	32.009	32.025	0.035
	0.9843	1.2598	0.945	0.780		6180	8660		0.9843	0.9839	1.2602	1.2608	
30	30	37	16	12.8	K30X37X16BE	21.60	29.80	0.0363	30.000	29.991	37.009	37.025	0.029
	1.1811	1.4567	0.630	0.504		4860	6700		1.1811	1.1807	1.4570	1.4577	
35	35	42	20	16.8	K35X42X20BE	29.70	47.00	0.0434	35.000	34.989	42.009	42.025	0.039
	1.3780	1.6535	0.787	0.661		6680	10600		1.3780	1.3775	1.6539	1.6545	

**ASSEMBLIES FOR WRIST PIN
END APPLICATIONS**
METRIC SERIES

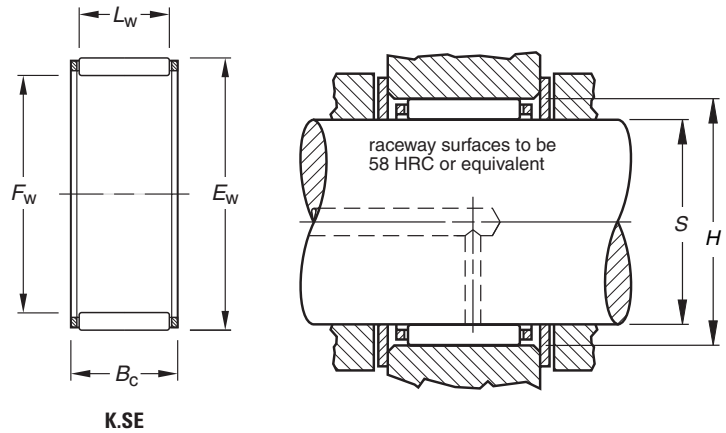

K.SE

Shaft Dia.	Dimensions mm/in. -0.2 -.008 -0.55 -.022				Assembly Designation	Load Ratings kN/lbf.			Mounting Dimensions mm/in. (non-high performance engines)				Wt. kg/lbs.
	F _w	E _w	B _c	L _w		C	C ₀	C _g	Max.	Min.	Min.	Max.	
mm	F _w	E _w	B _c	L _w		C	C ₀	C _g	S	H			
9	9	12	11.5	8.4	K9X12X11,5SE	4.23	4.53	0.0296	9.000	8.994	12.006	12.017	0.003
	0.3543	0.4724	0.453	0.331		951	1020		0.3543	0.3541	0.4727	0.4731	
9	9	13	12.5	9.8	K9X13X12,5SE	5.58	5.41	0.0306	9.000	8.994	13.006	13.017	0.005
	0.3543	0.5118	0.492	0.386		1250	1220		0.3543	0.3541	0.5120	0.5125	
10	10	13	14.5	11.8	K10X13X14,5SE	5.93	7.20	0.0152	10.000	9.994	13.006	13.017	0.004
	0.3937	0.5118	0.571	0.465		1330	1620		0.3937	0.3935	0.5120	0.5125	
10	10	14	10.0	7.0	K10X14X10SE	4.62	4.36	0.0155	10.000	9.994	14.006	14.017	0.004
	0.3937	0.5512	0.394	0.276		1040	980		0.3937	0.3935	0.5514	0.5519	
12	12	15	13.0	9.8	K12X15X13SE	6.00	7.72	0.0179	12.000	11.992	15.006	15.017	0.004
	0.4724	0.5906	0.512	0.386		1350	1740		0.4724	0.4721	0.5908	0.5912	
12	12	15	15.0	11.8	K12X15X15SE	6.97	9.36	0.0153	12.000	11.992	15.006	15.017	0.005
	0.4724	0.5906	0.591	0.465		1570	2100		0.4724	0.4721	0.5908	0.5912	
12	12	15	17.5	12.8	K12X15X17,5SE	7.45	10.2	0.0196	12.000	11.992	15.006	15.017	0.006
	0.4724	0.5906	0.689	0.504		1670	2290		0.4724	0.4721	0.5908	0.5912	
12	12	16	13.0	9.8	K12X16X13SE	6.03	6.38	0.0206	12.000	11.992	16.006	16.017	0.006
	0.4724	0.6299	0.512	0.386		1360	1430		0.4724	0.4721	0.6302	0.6306	
12	12	17	13.0	9.8	K12X17X13SE	7.61	7.54	0.0210	12.000	11.992	17.006	17.017	0.007
	0.4724	0.6693	0.512	0.386		1710	1700		0.4724	0.4721	0.6695	0.6700	
12	12	17	15.0	12.5	K12X17X15SE	9.30	9.75	0.0181	12.000	11.992	17.006	17.017	0.007
	0.4724	0.6693	0.591	0.492		2090	2190		0.4724	0.4721	0.6695	0.6700	
13	13	16	14.0	9.8	K13X16X14SE	5.62	7.23	0.0184	13.000	12.992	16.006	16.017	0.005
	0.5118	0.6299	0.551	0.386		1260	1630		0.5118	0.5115	0.6302	0.6306	
13	13	17	17.7	13.8	K13X17X17,7SE	9.80	12.3	0.0196	13.000	12.992	17.006	17.017	0.008
	0.5118	0.6693	0.697	0.543		2200	2770		0.5118	0.5115	0.6695	0.6700	
13	13	18	15.0	12.5	K13X18X15SE	9.28	9.88	0.0200	13.000	12.992	18.006	18.017	0.008
	0.5118	0.7087	0.591	0.492		2090	2220		0.5118	0.5115	0.7089	0.7093	
14	14	18	13.0	9.8	K14X18X13SE	7.39	8.69	0.0220	14.000	13.992	18.006	18.017	0.007
	0.5512	0.7087	0.512	0.386		1660	1950		0.5512	0.5509	0.7089	0.7093	
14	14	18	17.0	11.8	K14X18X17SE	8.59	10.5	0.0203	14.000	13.992	18.006	18.017	0.00
	0.5512	0.7087	0.669	0.465		1930	2360		0.5512	0.5509	0.7089	0.7093	
14	14	18	21.0	14.8	K14X18X21SE	10.3	13.3	0.0208	14.000	13.992	18.006	18.017	0.011
	0.5512	0.7087	0.827	0.583		2320	2990		0.5512	0.5509	0.7089	0.7093	
15	15	19	17.0	11.8	K15X19X17SE	9.05	11.5	0.0218	15.000	14.992	19.007	19.020	0.009
	0.5906	0.7480	0.669	0.465		2030	2590		0.5906	0.5902	0.7483	0.7488	
15	15	19	19.5	15.8	K15X19X19,5SE	10.8	14.3	0.0231	15.000	14.992	19.007	19.020	0.010
	0.5906	0.7480	0.768	0.622		2430	3210		0.5906	0.5902	0.7483	0.7488	
15	15	19	20.0	15.8	K15X19X20SE	10.8	14.3	0.0229	15.000	14.992	19.007	19.020	0.010
	0.5906	0.7480	0.787	0.622		2430	3210		0.5906	0.5902	0.7483	0.7488	
16	16	20	20.0	15.8	K16X20X20SE	12.0	16.9	0.0242	16.000	15.992	20.007	20.020	0.011
	0.6299	0.7874	0.787	0.622		2700	3800		0.6299	0.6296	0.7877	0.7882	
16	16	20	22.0	15.8	K16X20X22SE	12.0	16.9	0.0242	16.000	15.992	20.007	20.020	0.013
	0.6299	0.7874	0.866	0.622		2700	3800		0.6299	0.6296	0.7877	0.7882	
16	16	20	23.0	15.8	K16X20X23SE	10.7	14.5	0.0259	16.000	15.992	20.007	20.020	0.013
	0.6299	0.7874	0.906	0.622		2410	3260		0.6299	0.6296	0.7877	0.7882	

Continued on next page.



NEEDLE ROLLER BEARINGS

ASSEMBLIES FOR WRIST PIN END APPLICATIONS — *continued*

METRIC SERIES

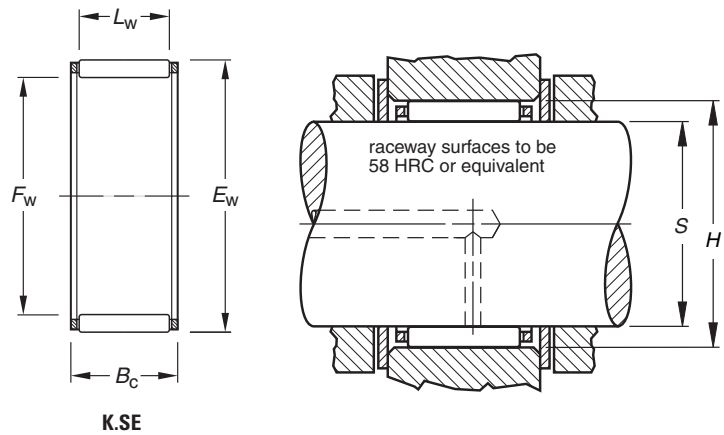

K.SE

Shaft Dia.	Dimensions mm/in. -0.2 - .008 -0.55 - .022				Assembly Designation	Load Ratings kN/lbf.			Mounting Dimensions mm/in. (non-high performance engines)				Wt. kg/lbs.
	F _w	E _w	B _c	L _w		C	C ₀	C _g	Max.	Min.	Min.	Max.	
mm	F _w	E _w	B _c	L _w		C	C ₀	C _g	S		H		
18	18	22	22.0	17.8	K18X22X22SE	14.4	22.0	0.0259	18.000	17.992	22.007	22.020	0.016
	0.7087	0.8661	0.866	0.701		3240	4950		0.7087	0.7083	0.8664	0.8669	
18	18	23	20.0	15.8	K18X23X20SE	13.6	17.6	0.0249	18.000	17.992	23.007	23.020	0.015
	0.7087	0.9055	0.787	0.622		3060	3960		0.7087	0.7083	0.9058	0.9063	
18	18	23	23.0	17.8	K18X23X23SE	15.9	21.6	0.0291	18.000	17.992	23.007	23.020	0.018
	0.7087	0.9055	0.906	0.701		3570	4860		0.7087	0.7083	0.9058	0.9063	
19	19	24	25.5	17.8	K19X24X25.5SE	16.7	23.4	0.0268	19.000	18.991	24.007	24.020	0.022
	0.7480	0.9449	1.004	0.701		3750	5260		0.7480	0.7477	0.9452	0.9457	
20	20	24	23.0	17.8	K20X24X23SE	14.8	23.7	0.0282	20.000	19.991	24.007	24.020	0.017
	0.7874	0.9449	0.906	0.701		3330	5330		0.7874	0.7870	0.9452	0.9457	
20	20	25	22.0	16.8	K20X25X22SE	15.9	22.2	0.0294	20.000	19.991	25.007	25.020	0.020
	0.7874	0.9843	0.866	0.661		3570	4990		0.7874	0.7870	0.9845	0.9850	
20	20	25	23.0	17.8	K20X25X23SE	17.5	25.2	0.0310	20.000	19.991	25.007	25.020	0.025
	0.7874	0.9843	0.906	0.701		3930	5670		0.7874	0.7870	0.9845	0.9850	

NEEDLE ROLLER AND CAGE RADIAL ASSEMBLIES

INCH SERIES

Timken® Torrington® inch series needle roller and cage radial assemblies are available in a variety of sizes and designs. This catalog includes the most popular standard designs.

REFERENCE STANDARDS:

- **ANSI/ABMA 18.2** – Needle roller bearings – Radial, inch design.

Before selecting specific inch series, needle roller and cage radial assemblies, the engineering section of this catalog should be reviewed.

Types Of Inch Series Needle Roller And Cage Radial Assemblies



WJ



WJC

There are two primary constructions of inch series needle roller and cage assemblies. The WJ assemblies generally employ larger diameter needle rollers whereas the WJC assemblies normally employ smaller diameter needle rollers.

CONSTRUCTION

Needle roller and cage radial assemblies have a steel cage which provides both inward and outward retention for the needle rollers. The designs provide maximum cage strength consistent with the inherent high load ratings of needle roller bearings.

Accurate guidance of the needle rollers by the cage bars allows for operation at high speeds. Needle roller and cage assemblies have either one or two rows of needle rollers.

Also available (on request) are needle roller and cage assemblies using molded, one piece glass reinforced engineered polymer cages. These operate well at temperatures up to 250° F (120° C) over extended periods. However, care should be exercised when bearings are lubricated with oils containing additives as service life may be reduced if the operating temperature exceeds 212° F (100° C). At such high temperatures oil can deteriorate with time and it is suggested that oil change intervals are observed.

Needle rollers with relieved ends used in these assemblies are made of high carbon chrome steel, through-hardened, ground and lapped to close tolerances for diameter and roundness. See the engineering section of this catalog for further discussion of relieved end rollers.

DIMENSIONAL ACCURACY

The nominal inch assemblies, WJ and WJC, contain needle rollers manufactured to only one diameter grade. Within any one assembly, the needle rollers have a total diameter tolerance of .0001 inch.

The limit to precision of the radial clearance of mounted needle roller and cage assemblies is the capability of the user to hold close tolerances on the inner and outer raceways.

The tolerance of the overall width of these assemblies is given on the tabular pages of this section.

MOUNTING DIMENSIONS

The cage and needle roller assembly normally uses the shaft and housing as the inner and outer raceways. In order to realize full bearing load rating and life, the shaft and housing must have the correct geometric and metallurgical characteristics.

The tables of dimensions for these assemblies list the suggested diameters for the shaft when used as the inner raceway. These are consistent with ISO h5 shaft raceway tolerances. Additional design details for shafts used as inner raceways can be found in the engineering section of this catalog.

Since the housing normally serves as the outer raceway, it should be of sufficient cross section to maintain adequate roundness and running clearance under load. The tables of dimensions also list the suggested diameters for the housings when used as outer raceways. These are consistent with ISO G6



NEEDLE ROLLER BEARINGS

housing bore tolerances. Additional design details for housings used as outer raceways can be found in the engineering section of this catalog.

The suggested mounting diameter tolerances for these needle roller and cage assemblies will provide correct running clearance for most applications.

The needle roller and cage assembly must be axially located by shoulders or other suitable means. End locating surfaces should be hardened to minimize wear. For satisfactory operation, minimum axial clearance should be 0.008 inch. When using type WJ assembly, fillets adjacent to the assembly must not exceed 0.03 inch radius. When it is necessary to use fillets adjacent to WJC assembly, please consult your Timken representative for suggestions.

C

LUBRICATION

Oil is the preferred lubricant for most applications. In critical applications involving high speeds, ample oil flow must be provided. Where assemblies are subjected to high centrifugal forces, such as in epicyclic gearing, or inertia forces, as in the small end of a connecting rod, the contact pressure between the cage and the raceway guiding surface becomes critical. The allowable contact pressure depends on a combination of the induced force and the rubbing velocity between the cage and the raceway and the rate of lubricant flow. Consult your Timken representative when cages will be subjected to high induced forces.

SPECIAL DESIGNS

Needle roller and cage assemblies made to special dimensions or configurations, such as those that are split to assemble around a one-piece crankshaft, can be made available on special order where quantities permit. Special plated cages to enhance life under conditions of high induced forces can also be made available.

SINGLE-ROW ASSEMBLIES
INCH SERIES

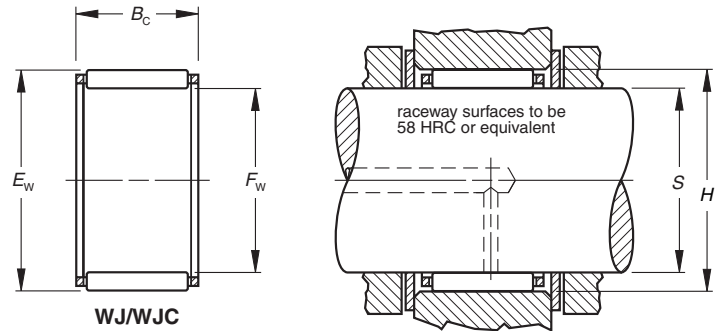

Shaft Dia.	Dimensions mm/in.			Assembly Designation	Load Ratings kN/lbf.		Limiting Speed		C _g	Max.	Min.	Min.	Max.	Wt. kg/lbs.
	-0.2 -.008 -0.55 -.022				C	C ₀	Grease	Oil						
in.	F _w	E _w	B _c		C	C ₀								
3/8	9.525 0.3750	12.700 0.5000	9.53 0.375	WJC-060806	3.87 870	4.00 900	24000	37000	0.0170	9.525 0.3750	9.520 0.3748	12.705 0.5002	12.715 0.5006	0.003 0.006
1/2	12.700 0.5000	15.875 0.6250	12.70 0.500	WJC-081008	6.23 1 400	8.01 1 800	23000	35000	0.0227	12.700 0.5000	12.692 0.4997	15.880 0.6252	15.890 0.6256	0.005 0.010
9/16	14.288 0.5625	17.463 0.6875	12.70 0.500	WJC-091108	6.81 1 530	9.25 2 080	22000	34000	0.0247	14.288 0.5625	14.280 0.5622	17.468 0.6877	17.478 0.6881	0.006 0.013
5/8	15.875 0.6250	19.050 0.7500	12.70 0.500	WJC-101208	7.03 1 580	9.96 2 240	18000	27000	0.0264	15.875 0.6250	15.867 0.6247	19.058 0.7503	19.070 0.7508	0.006 0.013
	15.875 0.6250	22.225 0.8750	15.88 0.625	WJ-101410	15.6 3 510	17.8 3 990	19000	29000	0.0280	15.875 0.6250	15.867 0.6247	22.233 0.8753	22.245 0.8758	0.012 0.027
3/4	15.875 0.6250	22.225 0.8750	22.23 0.875	WJ-101414	21.3 4 780	26.4 5 940	19000	29000	0.0309	15.875 0.6250	15.867 0.6247	22.233 0.8753	22.245 0.8758	0.017 0.038
	19.050 0.7500	25.400 1.0000	25.40 1.000	WJ-121616	26.8 6 020	37.2 8 370	16000	24000	0.0362	19.050 0.7500	19.040 0.7496	25.408 1.0003	25.420 1.0008	0.023 0.051
13/16	20.638 0.8125	26.988 1.0625	22.23 0.875	WJ-131714	25.1 5 650	35.0 7 880	14000	22000	0.0368	20.638 0.8125	20.627 0.8121	26.995 1.0628	27.008 1.0633	0.021 0.046
7/8	22.225 0.8750	28.575 1.1250	25.40 1.000	WJ-141816	29.2 6 570	43.5 9 770	13000	20000	0.0401	22.225 0.8750	22.215 0.8746	28.583 1.1253	28.595 1.1258	0.026 0.058
1	25.400 1.0000	33.338 1.3125	19.05 0.750	WJ-162112	28.1 6 320	37.1 8 340	12000	18000	0.0397	25.400 1.0000	25.390 0.9996	33.348 1.3129	33.363 1.3135	0.029 0.063
	25.400 1.0000	33.338 1.3125	25.40 1.000	WJ-162116	36.8 8 270	52.5 11 800	12000	18000	0.0432	25.400 1.0000	25.390 0.9996	33.348 1.3129	33.363 1.3135	0.038 0.084
	25.400 1.0000	33.338 1.3125	31.75 1.250	WJ-162120	44.5 10 000	67.2 15 100	12000	18000	0.0460	25.400 1.0000	25.390 0.9996	33.348 1.3129	33.363 1.3135	0.048 0.105
1 1/8	28.575 1.1250	38.100 1.5000	25.40 1.000	WJ-182416	42.4 9 520	57.8 13 000	10000	16000	0.0455	28.575 1.1250	28.565 1.1246	38.110 1.5004	38.125 1.5010	0.041 0.090
	28.575 1.1250	38.100 1.5000	31.75 1.250	WJ-182420	52 11 700	74.7 16 800	10000	16000	0.0485	28.575 1.1250	28.565 1.1246	38.110 1.5004	38.125 1.5010	0.065 0.143
1 1/4	31.750 1.2500	41.275 1.6250	19.05 0.750	WJ-202612	33.4 7 520	43.7 9 830	9300	14000	0.0443	31.750 1.2500	31.740 1.2496	41.285 1.6254	41.300 1.6260	0.043 0.094
	31.750 1.2500	41.275 1.6250	25.40 1.000	WJ-202616	44.1 9 910	62.3 14 000	9300	14000	0.0484	31.750 1.2500	31.740 1.2496	41.285 1.6254	41.300 1.6260	0.061 0.134
	31.750 1.2500	41.275 1.6250	31.75 1.250	WJ-202620	53.8 12 100	81.0 18 200	9300	14000	0.0517	31.750 1.2500	31.740 1.2496	41.285 1.6254	41.300 1.6260	0.071 0.156
	31.750 1.2500	41.275 1.6250	38.10 1.500	WJ-202624	63.6 14 300	99.6 22 400	9300	14000	0.0544	31.750 1.2500	31.740 1.2496	41.285 1.6254	41.300 1.6260	0.085 0.188
1 3/8	34.925 1.3750	44.450 1.7500	25.40 1.000	WJ-222816	45.8 10 300	67.2 15 100	8300	13000	0.0513	34.925 1.3750	34.915 1.3746	44.460 1.7504	44.475 1.7510	0.067 0.147
	34.925 1.3750	44.450 1.7500	31.75 1.250	WJ-222820	56.0 12 600	87.2 19 600	8300	13000	0.0547	34.925 1.3750	34.915 1.3746	44.460 1.7504	44.475 1.7510	0.077 0.170
1 1/2	38.100 1.5000	47.625 1.8750	25.40 1.000	WJ-243016	47.2 10 600	71.6 16 100	7600	12000	0.0541	38.100 1.5000	38.090 1.4996	47.635 1.8754	47.650 1.8760	0.078 0.172
	38.100 1.5000	47.625 1.8750	31.75 1.250	WJ-243020	57.8 13 000	93.0 20 900	7600	12000	0.0577	38.100 1.5000	38.090 1.4996	47.635 1.8754	47.650 1.8760	0.083 0.184
	38.100 1.5000	47.625 1.8750	38.10 1.500	WJ-243024	68.1 15 300	114.8 25 800	7600	12000	0.0608	38.100 1.5000	38.090 1.4996	47.635 1.8754	47.650 1.8760	0.100 0.220

Load Ratings are based on a minimum raceway hardness of 58 HRC or equivalent.

Minimum axial clearance should be .02 mm, .008 in.

Continued on next page.



NEEDLE ROLLER BEARINGS

Shaft Dia.	Dimensions mm/in.			Assembly Designation	Load Ratings kN/bf.		Limiting Speed		Grease	Oil	Max.	Min.	Min.	Max.	Wt. kg/lbs.
	F _w	E _w	B _c		C	C ₀	RPM	C _g							
1	38.100	47.625	44.45	WJ-243028	77.4	135.7	7600	12000	0.0634	38.100	38.090	47.635	47.650	0.13	
	1.5000	1.8750	1.750		17 400	30 500									1.5000
1 3/4	44.450	53.975	19.05	WJ-283412	39.5	59.6	6400	9900	0.0552	44.450	44.440	53.985	54.003	0.058	
	1.7500	2.1250	0.750		8 870	13 400									1.7500
1 1/2	44.450	53.975	25.40	WJ-283416	52.0	85.0	6400	9900	0.0603	44.450	44.440	53.985	54.003	0.084	
	1.7500	2.1250	1.000		11 700	19 100									1.7500
1 1/4	44.450	53.975	38.10	WJ-283424	74.7	136	6400	9900	0.0677	44.450	44.440	53.985	54.003	0.115	
	1.7500	2.1250	1.500		16 800	30 600									1.7500
2	50.800	60.325	19.05	WJ-323812	42.8	69	5600	8600	0.0606	50.800	50.787	60.335	60.353	0.065	
	2.0000	2.3750	0.750		9 610	15 500									2.0000
1 3/4	50.800	60.325	25.40	WJ-323816	56.5	98	5600	8600	0.0662	50.800	50.787	60.335	60.353	0.105	
	2.0000	2.3750	1.000		12 700	22 100									2.0000
1 1/2	50.800	60.325	31.75	WJ-323820	69.0	127	5600	8600	0.0707	50.800	50.787	60.335	60.353	0.10	
	2.0000	2.3750	1.250		15 500	28 700									2.0000
1 1/4	50.800	60.325	38.10	WJ-323824	81.0	157	5600	8600	0.0744	50.800	50.787	60.335	60.353	0.130	
	2.0000	2.3750	1.500		18 200	35 300									2.0000
2 1/16	52.388	61.913	25.40	WJ-333916	57.8	102	5400	8300	0.0678	52.388	52.375	61.923	61.940	0.099	
	2.0625	2.4375	1.000		13 000	23 100									2.0625
2 1/8	53.975	63.500	25.40	WJ-344016	52.5	92.08	5200	8000	0.0668	53.975	53.962	63.510	63.528	0.089	
	2.1250	2.5000	1.000		11 800	20 700									2.1250
1 3/4	53.975	63.500	38.10	WJ-344024	78.3	153	5200	8000	0.0759	53.975	53.962	63.510	63.528	0.137	
	2.1250	2.5000	1.500		17 600	34 500									2.1250
2 3/16	55.563	65.088	19.05	WJ-354112	44.5	75.17	5000	7800	0.0644	55.563	55.550	65.098	65.115	0.070	
	2.1875	2.5625	.750		10 000	16 900									2.1875
1 3/4	55.563	65.088	25.40	WJ-354116	57.8	107	5000	7800	0.0704	55.563	55.550	65.098	65.115	0.094	
	2.1875	2.5625	1.000		13 000	24 100									2.1875
2 1/4	57.150	66.675	25.40	WJ-364216	53.8	96.08	4900	7500	0.0693	57.150	57.137	66.685	66.703	0.096	
	2.2500	2.6250	1.000		12 100	21 600									2.2500
1 3/4	57.150	66.675	31.75	WJ-364220	67.6	128	4900	7500	0.0745	57.150	57.137	66.685	66.703	0.120	
	2.2500	2.6250	1.250		15 200	28 900									2.2500
2 3/8	60.325	69.850	38.10	WJ-384424	81.4	167	4600	7100	0.0815	60.325	60.312	69.860	69.878	0.151	
	2.3750	2.7500	1.500		18 300	37 600									2.3750
2 1/2	63.500	73.025	25.40	WJ-404616	55.6	104	4400	6700	0.0741	63.500	63.487	73.035	73.053	0.106	
	2.5000	2.8750	1.000		12 500	23 400									2.5000
1 3/4	63.500	73.025	31.75	WJ-404620	69.8	139	4400	6700	0.0797	63.500	63.487	73.035	73.053	0.132	
	2.5000	2.8750	1.250		15 700	31 400									2.5000
1 3/4	63.500	73.025	38.10	WJ-404624	83.2	173	4400	6700	0.0842	63.500	63.487	73.035	73.053	0.179	
	2.5000	2.8750	1.500		18 700	39 100									2.5000
2 3/4	69.850	79.375	25.40	WJ-445016	57.8	112.54	4000	6100	0.0788	69.850	69.837	79.385	79.403	0.116	
	2.7500	3.1250	1.000		13 000	25 300									2.7500
3	76.200	85.725	25.40	WJ-485416	59.6	120.55	3600	5600	0.0833	76.200	76.187	85.738	85.761	0.126	
	3.0000	3.3750	1.000		13 400	27 100									3.0000
1 3/4	76.200	85.725	38.10	WJ-485424	85.4	191.72	3600	5600	0.0935	76.200	76.187	85.738	85.761	0.189	
	3.0000	3.3750	1.500		19 200	43 100									3.0000
3 1/4	82.550	92.075	25.40	WJ-525816	61.4	128.55	3300	5100	0.0878	82.550	82.535	92.088	92.111	0.136	
	3.2500	3.6250	1.000		13 800	28 900									3.2500
1 3/4	82.550	92.075	38.10	WJ-525824	88.1	204.62	3300	5100	0.0985	82.550	82.535	92.088	92.111	0.220	
	3.2500	3.6250	1.500		19 800	46 000									3.2500
3 1/2	88.900	98.425	25.40	WJ-566216	63.2	136.56	3100	4700	0.0922	88.900	88.885	98.438	98.461	0.146	
	3.5000	3.8750	1.000		14 200	30 700									3.5000
1 3/4	88.900	101.600	25.40	WJ-566416	79.6	150.35	3100	4800	0.0903	88.900	88.885	101.613	101.636	0.197	
	3.5000	4.0000	1.000		17 900	33 800									3.5000
1 3/4	88.900	101.600	38.10	WJ-566424	113	237.53	3100	4800	0.1011	88.900	88.885	101.613	101.636	0.296	
	3.5000	4.0000	1.500		25 600	53 400									3.5000
4	101.600	114.300	25.40	WJ-647216	83.6	166.59	2700	4200	0.0983	101.600	101.585	114.313	114.336	0.224	
	4.0000	4.5000	1.000		18 800	37 450									4.0000
1 3/4	101.600	114.300	38.10	WJ-647224	119	263.33	2700	4200	0.1102	101.600	101.585	114.313	114.336	0.335	
	4.0000	4.5000	1.500		26 800	59 200									4.0000
5	127.000	152.400	38.10	WJ-809624	211	365.20	2200	3400	0.1196	127.000	126.982	152.415	152.438	1.018	
	5.0000	6.0000	1.500		47 600	82 100									5.0000

Load Ratings are based on a minimum raceway hardness of 58 HRC or equivalent.

Minimum axial clearance should be .02 mm, .008 in.

DRAWN CUP NEEDLE ROLLER BEARINGS

Overview: Drawn cup needle roller bearings support radial loads and reduce friction between rotating components, with a drawn outer shell serving as a raceway for the rollers. The low cross section of the drawn cup bearing provides high load-carrying capability with minimum required space. Drawn cup bearings are easily installed with a press fit in the housing.

- **Sizes:** 3 mm - 60 mm bore (1/8 in. - 5 1/2 in. bore).
- **Markets:** Transmissions, transfer cases, engines, valve trains, steering and braking systems, axle supports, outboard engines, power tools, copiers, fax machines, paper-moving equipment and appliances.
- **Features:** Available in two basic designs: full complement and caged.
- **Benefits:** Full complement handles high radial load-carrying capability at a low cost. Caged provides high speed and maximum lubricant retention capability.

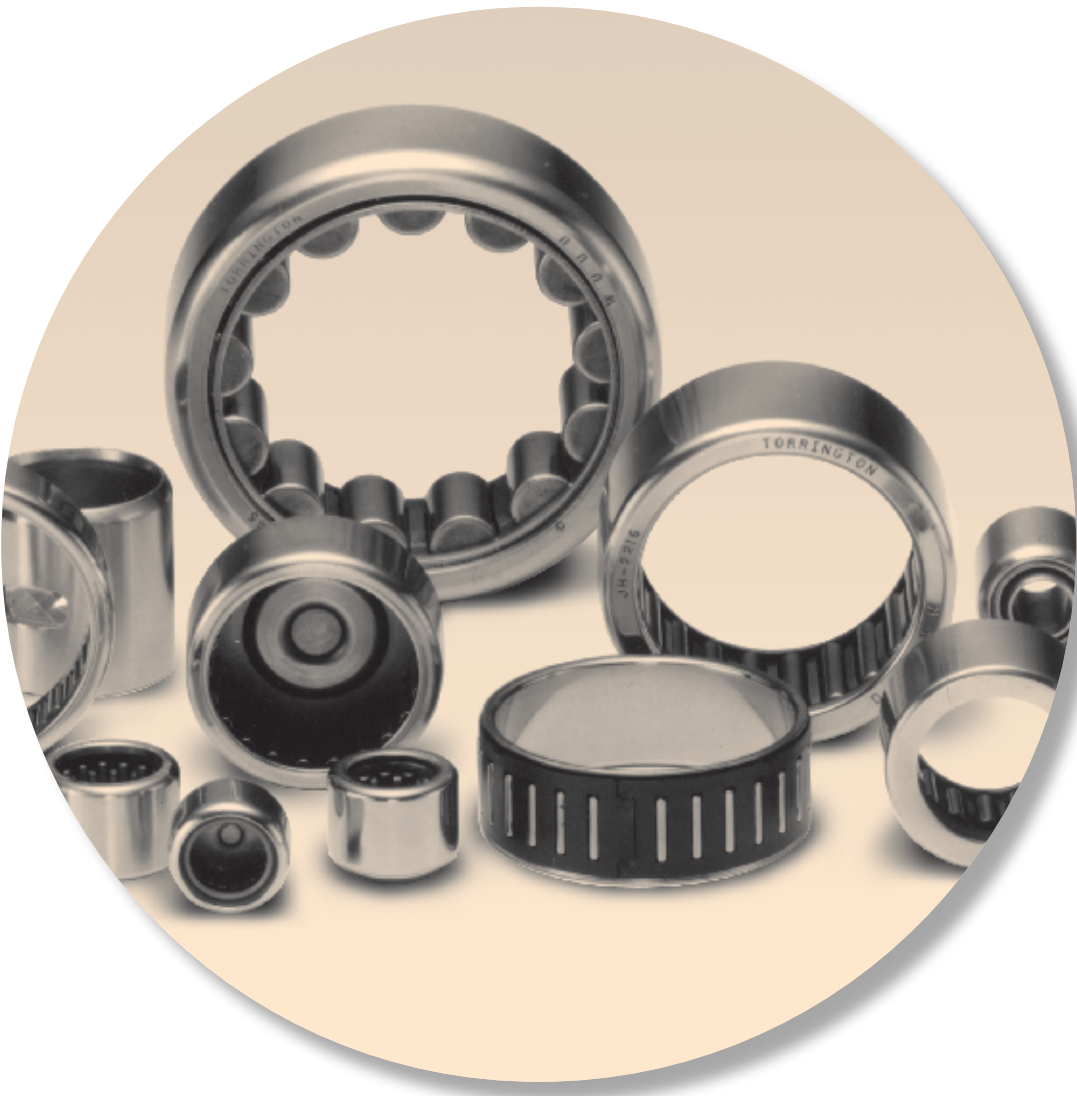

Drawn Cup Needle Roller Bearings – Metric Nominal Dimensions

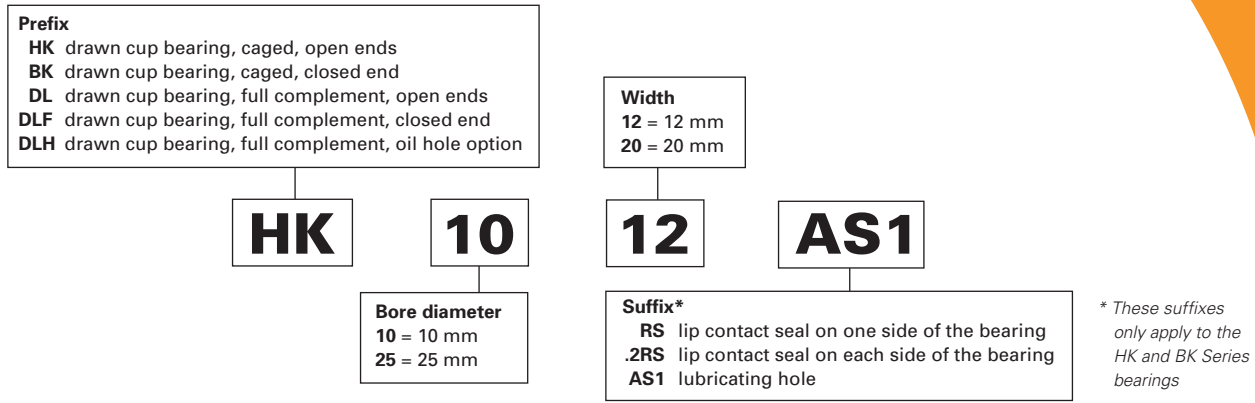

Inner Rings – Metric Nominal Dimensions

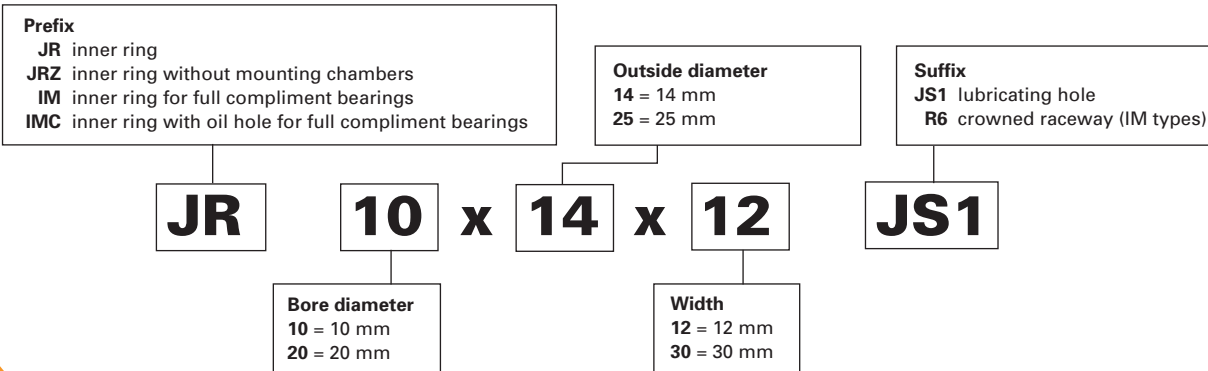

Drawn Cup Needle Roller Bearings – Inch Nominal Dimensions

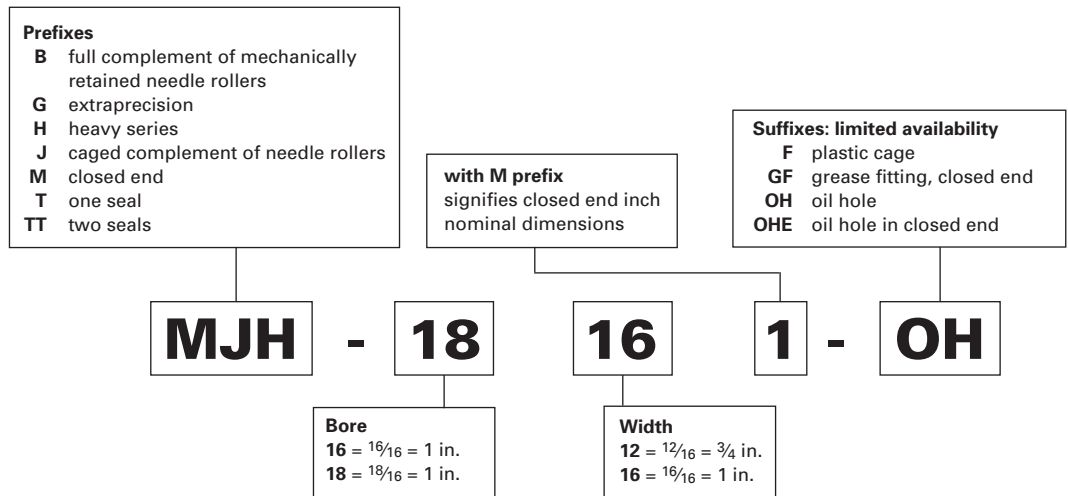

Inner Rings (with 4-digit number) Inch Nominal Dimensions

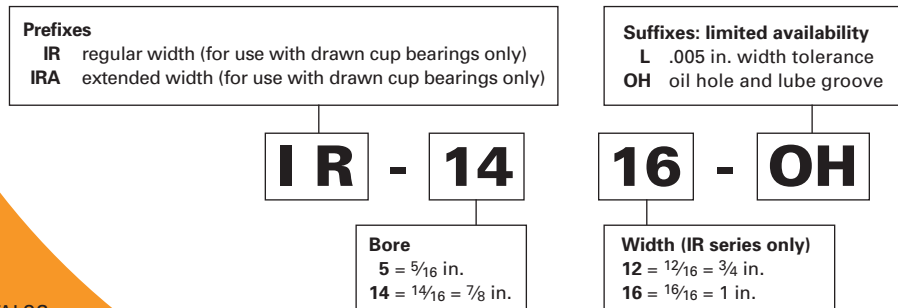

Drawn Cup Bearings

	<i>Page</i>
Introduction	C38
Open Ends, Closed One End – Metric Series	C42
Sealed Bearings – Metric Series.....	C50
Drawn Cup Needle Roller Bearings – Inch Series.....	C58
Full Complement Bearings, Caged Bearings – Open Ends, Closed One End – Inch Series	C66
Extra-Precision Bearings – Inch Series	C80
Caged Bearings – Open Ends, Closed One End – Inch Series	C82
Sealed Drawn Cup Bearings – Inch Series	C90
Inner Rings for Inch Series Drawn Cup Bearings	C92





DRAWN CUP NEEDLE ROLLER BEARINGS

METRIC SERIES

When a rolling bearing is needed for a compact and economic design and where it is not practical to harden and grind the housing bore, or where the housing materials are of low rigidity such as cast iron, aluminum or even plastics, drawn cup needle roller bearings should be considered.

REFERENCE STANDARDS ARE:

- **ISO 3245** – Rolling bearings – Needle roller bearings, drawn cup, without inner ring, boundary dimensions and tolerances.
- **ANSI/ABMA 18.1** – Needle roller bearings – Radial, metric design.
- **DIN 618** – Needle roller bearings with cage – Drawn cups with open end, drawn cup with closed end.

Before selecting specific drawn cup needle roller bearings, the engineering section of this catalog should be reviewed.

Types Of Metric Series Drawn Cup Needle Roller Bearings

Drawn cup needle roller bearing, open ends

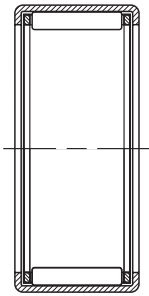

HK

Drawn cup needle roller bearing, closed end

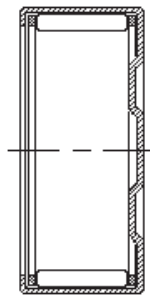

BK

Drawn cup needle roller bearings, open ends, sealed

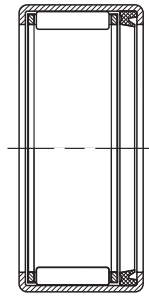

HKRS

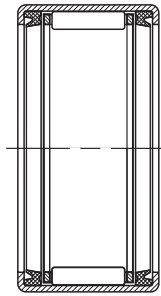

HK.2RS

Suffixes

AS1	lubricating hole
RS	one seal
.2RS	two seals

CONSTRUCTION

The prefix letters in metric series drawn cup bearing designations denote whether the bearings are made with a full complement of needle rollers or caged needle rollers. The use of a full complement of needle rollers is indicated by the prefix code letters DL or DLF and for use of caged needle rollers by the prefix code letters HK or BK.

The outer ring, in the form of a cup, is accurately drawn and no subsequent machining is performed. Drawn cup needle roller bearings of series HK and DL have open ends. The HK Series are also available with one seal, HKRS, and with two seals, HK.2RS. The stamped lip of a drawn cup needle roller bearing of series HKRS with one seal is at the seal end.

Drawn cup needle roller bearings of series BK and DLF are closed at one end. They are used for shaft end mounting. The open end is not sealed.

The one-piece steel cage used in HK Series drawn cup bearings is designed to provide rigidity and minimize wear. This cage design separates the needle roller guiding and retention functions.

Drawn cup needle roller bearings are manufactured with two needle roller and cage assemblies. They have a lubricating hole in the outer ring. Metric series drawn cup bearings with one needle roller and cage assembly may be made available on request with a lubricating hole, indicated by suffix AS1.

SEALED BEARINGS

The HK Series drawn cup bearings are offered with integral seals. The tables of dimensions on page C50 indicates those sizes available with lip contact seals. The seal lip design achieves a light and constant contact with the inner raceway throughout the range

of mounted bearing clearances thereby ensuring positive sealing and low frictional drag.

Sealed drawn cup bearings are intended to retain grease or non-pressurized oil within a bearing while also preventing contaminants entering the raceway area.

Details of shaft design for sealed bearings are given in the engineering section of this catalog.

The standard lip contact seals are compatible with common lubricating oils and petroleum based fuels, but they are adversely affected by certain fire-resistant hydraulic fluids and most common solvents. Sealed drawn cup bearings are normally filled with a high quality lithium soap base general purpose grease. The seal material and grease properties limit the bearing operating temperature between -30° C and +100° C.

If the operating temperature must be outside of the range for the seals mentioned here, or if the seals are exposed to unusual fluids please consult your Timken automotive representative.

BEARING MOUNTING FITS AND INTERNAL CLEARANCE

Drawn cup bearings are manufactured to a degree of precision that will satisfy the radial clearance requirements of most applications. The total radial clearance for an installed drawn cup bearing results from the build up of manufacturing tolerances of the housing bore, the inner raceway diameter and the bearing, as well as the minimum radial clearance required for the application.

For metric series drawn cup bearings requiring close control of radial internal clearance, the suggested housing bore tolerance is N6 and h5 tolerance for the inner raceway diameter. When such exacting close control of radial internal clearance is not required, the user may select N7 housing bore and h6 inner raceway diameter tolerances.

TOLERANCES FOR HOUSING MATERIALS OF LOW RIGIDITY

Metric series drawn cup bearings used in housings made from materials of low rigidity or steel housings of small section, the suggested housing bore tolerance is R6 (R7). To maintain normal radial internal clearance the inner raceway diameter tolerance should be h5 (h6).

OUTER RING ROTATION

For metric series drawn cup bearing applications where the outer ring rotates with respect to the load, it is suggested that both the housing bore and the inner raceway diameter be reduced using R6 (R7) and f5 (f6) tolerance practice respectively.

OSCILLATING MOTION

Metric series drawn cup bearing applications involving oscillating motion may require reduced radial internal clearances. This reduction may be accomplished by increasing the inner raceway diameter using j6 tolerance.

INNER RINGS

When it becomes impractical to meet the shaft raceway design requirements (hardness, case depth, surface finish etc.) outlined in the engineering section, standard inner rings may be used with metric series drawn cup bearings. It is suggested that when metric series inner rings are used with metric series drawn cup bearings, they should be mounted with a loose transition fit on the shaft using g6 (g5) shaft diameter tolerance. The inner ring should be end-clamped against a shoulder. If a tight transition fit must be used, [shaft diameter tolerance h6 (h5)], to keep the inner ring from rotating relative to the shaft, the inner ring outside diameter, as mounted, must not exceed the raceway diameter required by the drawn cup bearing for the particular application. In case the outside diameter of the inner ring, when mounted on the shaft, exceeds the required raceway diameter for the matching drawn cup bearing, it should be ground to proper diameter while mounted on the shaft.

LOAD RATING FACTORS

DYNAMIC LOADS

Drawn cup needle roller bearings can accommodate only radial loads.

$$P = F_r$$

P = The maximum dynamic radial load that may be applied to a drawn cup bearing based on the dynamic load rating, C given in the tabular pages. This load should be $\leq C/3$.

STATIC LOADS

$$f_0 = \frac{C_0}{P_0}$$

f_0 – static load safety factor

C_0 – basic static load rating (kN)

P_0 – maximum applied static load (kN)

To ensure satisfactory operation of drawn cup needle roller bearings under all types of conditions the static load safety factor f_0 should be ≥ 3 .

ADJUSTED RATING LIFE

When application data includes details of operating temperature, oil viscosity, operating speed and the applied load meets the $\leq C/3$ condition adjusted rating life may be evaluated using the information given in the engineering section of this catalog.

C





INSPECTION OF DRAWN CUP NEEDLE ROLLER BEARINGS

Although the bearing cup is accurately drawn from strip steel, because of its fairly thin section it may go out of round during heat treatment. When the bearing is pressed into a true round housing or ring gage, of correct size and wall thickness, it becomes round and is sized properly. For this reason, it is incorrect to inspect an unmounted drawn cup bearing by measuring the outside diameter. The correct method for inspecting the bearing size is to:

1. press the bearing into a ring gage of proper size
2. plug the bearing bore with the appropriate "go" and "no go" gages or measure it with a tapered arbor (lathe mandrel)

The "go" gage size is the minimum needle roller complement bore diameter. The "no go" gage size is larger than the maximum needle roller complement bore diameter by 0.002 mm.

TABLE 1 – HK SERIES BEARINGS

Nominal Bore Diameter mm	Ring Gage *	Dimensions – mm Needle Roller Complement Bore Diameter	
		Min.	Max.
		$F_{ws\ min}$	
3	6.484	3.006	3.024
4	7.984	4.010	4.028
5	8.984	5.010	5.028
6	9.984	6.010	6.028
7	10.980	7.013	7.031
8	11.980	8.013	8.031
9	12.980	9.013	9.031
10	13.980	10.013	10.031
12	15.980	12.016	12.034
12	17.980	12.016	12.034
13	18.976	13.016	13.034
14	19.976	14.016	14.034
15	20.976	15.016	15.034
16	21.976	16.016	16.034
17	22.976	17.016	17.034
18	23.976	18.016	18.034
20	25.976	20.020	20.041
22	27.976	22.020	22.041
25	31.972	25.020	25.041
28	34.972	28.020	28.041
30	36.972	30.020	30.041
35	41.972	35.025	35.050
40	46.972	40.025	40.050
45	51.967	45.025	45.050
50	57.967	50.025	50.050
60	67.967	60.030	60.060

*The ring gage sizes are in accordance with ISO N6 lower limit.

INSTALLATION PROCEDURES

GENERAL INSTALLATION REQUIREMENTS

- A drawn cup bearing must be pressed into its housing.
- An installation tool, similar to the one illustrated, must be used in conjunction with a standard press.
- The bearing must not be hammered into its housing even in conjunction with the proper assembly mandrel.
- The bearing must not be pressed tightly against a shoulder in the housing.
- If it is necessary to use a shouldered housing, the depth of the housing bore must be sufficient to ensure that the housing shoulder fillet, as well as the shoulder face, clears the bearing.
- The installation tool must be coaxial with the housing bore.

INSTALLATION OF OPEN END BEARINGS

It is advisable to utilize a positive stop on the press tool to locate the bearing properly in the housing. The assembly tool should have a leader or a pilot, as shown, to aid in starting the bearing true in the housing. The "O" ring shown on the drawing may be used to assist in holding the bearing on the installation tool. The bearing should be installed with the marked end (the end with the identification markings) against the angled shoulder of the pressing tool.

- A – 0.4 mm less than housing bore
- B – 0.08 mm less than shaft diameter
- C – distance bearing will be inset into housing, minimum of 0.2 mm
- D – pilot length should be length of bearing less 0.8 mm
- E – approximately $\frac{1}{2} D$

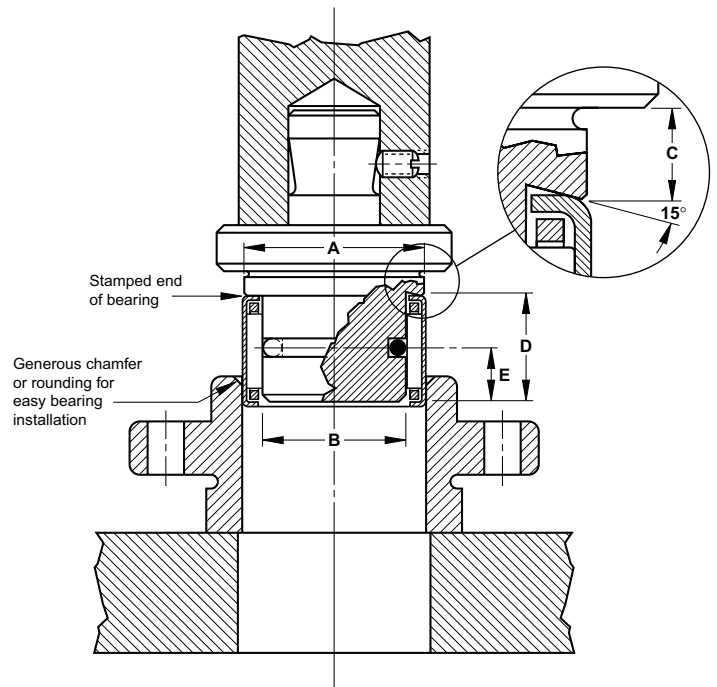

INSTALLATION OF CLOSED END BEARINGS

Bearing can be piloted from below for installation.

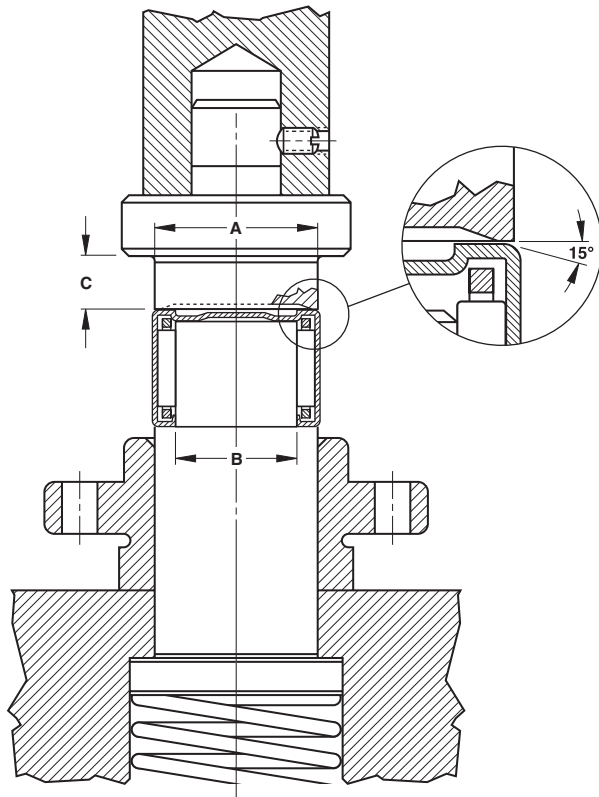

EXTRACTION FROM A STRAIGHT HOUSING

Bearing can be extracted by pushing it through the housing. After extraction, the drawn cup bearing should not be reused.

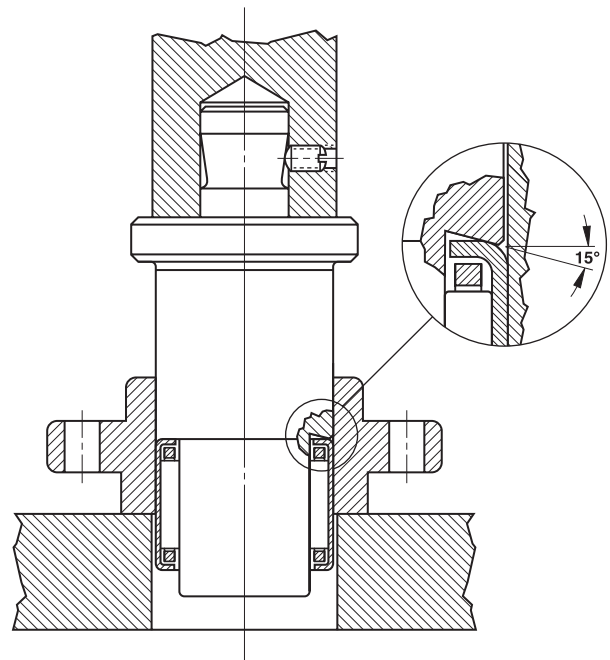



NEEDLE ROLLER BEARINGS

OPEN ENDS, CLOSED ONE END METRIC SERIES

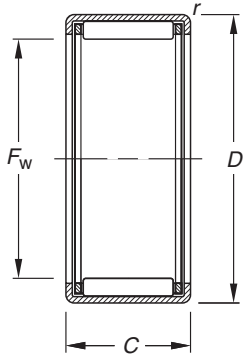

HK

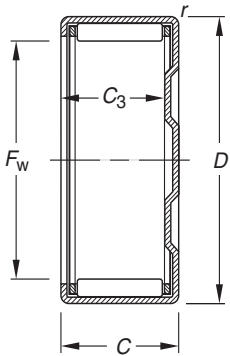

BK

Shaft Dia.	Dimensions mm/in.					Bearing Designation	Load Ratings kN/lbf.		Limiting Speed Approx.		C ₉	
	mm	F _w	D	C	C _{3 min}		r _{s min}	Dynamic	Static	Grease		Oil
3	3	3	7	6	—	0.3	HK0306	1.6	1.14	30000	46000	0.0065
		0.1181	0.2559	0.236		0.012		360	256			
4	4	4	8	8	—	0.4	HK0408	1.88	1.32	25000	39000	0.0083
		0.1575	0.315	0.315		0.016		423	297			
5	5	5	9	9	7.4	0.4	BK0509	2.52	2.07	23000	36000	0.01
		0.1969	0.3543	0.354	0.291	0.016		567	465			
6	5	5	9	9	—	0.4	HK0509	2.52	2.07	23000	36000	0.01
		0.1969	0.3543	0.354		0.016		567	465			
6	6	6	10	8	—	0.4	HK0608	2.34	1.95	22000	33000	0.0105
		0.2362	0.3937	0.315		0.016		526	438			
6	6	6	10	9	7.4	0.4	BK0609	3.14	2.85	22000	33000	0.0116
		0.2362	0.3937	0.354	0.291	0.016		706	641			
6	6	6	10	9	—	0.4	HK0609	3.15	2.94	22000	33000	0.0116
		0.2362	0.3937	0.354		0.016		708	661			
7	7	7	11	9	7.4	0.4	BK0709	3.23	3.05	21000	32000	0.0125
		0.2756	0.4331	0.354	0.291	0.016		726	686			
7	7	7	11	9	—	0.4	HK0709	3.22	3.12	21000	32000	0.0125
		0.2756	0.4331	0.354		0.016		724	701			
8	8	8	12	8	6.4	0.4	BK0808	2.9	2.73	20000	31000	0.0128
		0.315	0.4724	0.315	0.252	0.016		652	614			
8	8	8	12	8	—	0.4	HK0808	2.9	2.73	20000	31000	0.0128
		0.315	0.4724	0.315		0.016		652	614			
8	8	8	12	10	8.4	0.4	BK0810	3.93	4.14	20000	31000	0.0184
		0.315	0.4724	0.394	0.331	0.016		883	931			
8	8	8	12	10	—	0.4	HK0810	3.95	4.07	20000	31000	0.0186
		0.315	0.4724	0.394		0.016		888	915			
9	9	9	13	10	8.4	0.4	BK0910	4.57	5.07	19000	30000	0.0206
		0.3543	0.5118	0.394	0.331	0.016		1030	1140			
9	9	9	13	10	—	0.4	HK0910	4.57	5.07	19000	30000	0.0206
		0.3543	0.5118	0.394		0.016		1030	1140			
9	9	9	13	12	10.4	0.4	BK0912	5.65	6.65	19000	30000	0.022
		0.3543	0.5118	0.472	0.409	0.016		1270	1490			
9	9	9	13	12	—	0.4	HK0912	5.65	6.65	19000	30000	0.022
		0.3543	0.5118	0.472		0.016		1270	1490			
10	10	10	14	10	8.4	0.4	BK1010	4.78	5.51	19000	29000	0.0219
		0.3937	0.5512	0.394	0.331	0.016		1070	1240			
10	10	10	14	10	—	0.4	HK1010	4.78	5.51	19000	29000	0.0219
		0.3937	0.5512	0.394		0.016		1070	1240			
10	10	10	14	12	10.4	0.4	BK1012	5.9	7.23	19000	29000	0.0239
		0.3937	0.5512	0.472	0.409	0.016		1330	1630			
10	10	10	14	12	—	0.4	HK1012	5.9	7.23	19000	29000	0.0235
		0.3937	0.5512	0.472		0.016		1330	1630			
10	10	10	14	15	—	0.4	HK1015	7.49	9.81	19000	29000	0.0253
		0.3937	0.5512	0.591		0.016		1680	2210			
12	12	12	16	10	8.4	0.4	BK1210	4.96	6.08	18000	28000	0.0243
		0.4724	0.6299	0.394	0.331	0.016		1120	1370			
12	12	12	16	10	—	0.4	HK1210	4.96	6.08	18000	28000	0.0243
		0.4724	0.6299	0.394		0.016		1120	1370			
12	12	12	18	12	9.3	1	BK1212	6.61	7.29	14000	22000	0.0245
		0.4724	0.7087	0.472	0.366	0.039		1490	1640			
12	12	12	18	12	—	1	HK1212	6.61	7.29	14000	22000	0.0245
		0.4724	0.7087	0.472		0.039		1490	1640			
13	13	13	19	12	9.3	1	BK1312	6.92	7.89	14000	22000	0.0258
		0.5118	0.748	0.472	0.366	0.039		1560	1770			
13	13	13	19	12	—	1	HK1312	6.92	7.89	14000	22000	0.0258
		0.5118	0.748	0.472		0.039		1560	1770			
14	14	14	20	12	9.3	1	BK1412	7.21	8.5	14000	21000	0.0271
		0.5512	0.7874	0.472	0.366	0.039		1620	1910			

Wt. kg/lbs.	Mounting Dimensions mm/in.					Plug Gage		C _g	Matching Inner Ring	Shaft Dia. mm
	Max.	Min.	Min.	Max.	Ring Gage	Go	No-Go			
	S		H							
0.001 0.002	3 0.1181	2.996 0.118	6.487 0.2554	6.495 0.2557	6.484 0.2553	3.006 0.1183	3.026 0.1191			3
0.002 0.004	4 0.1575	3.995 0.1573	7.984 0.3143	7.993 0.3147	7.984 0.3143	4.01 0.1579	4.03 0.1587			4
0.002 0.004	5 0.1969	4.995 0.1967	8.984 0.3537	8.993 0.3541	8.984 0.3537	5.01 0.1972	5.03 0.198			5
0.002 0.004	5 0.1969	4.995 0.1967	8.984 0.3537	8.993 0.3541	8.984 0.3537	5.01 0.1972	5.03 0.198			5
0.002 0.004	6 0.2362	5.995 0.236	9.984 0.3931	9.993 0.3934	9.984 0.3931	6.01 0.2366	6.03 0.2374			6
0.003 0.007	6 0.2362	5.995 0.236	9.984 0.3931	9.993 0.3934	9.984 0.3931	6.01 0.2366	6.03 0.2374			6
0.002 0.004	6 0.2362	5.995 0.236	9.984 0.3931	9.993 0.3934	9.984 0.3931	6.01 0.2366	6.03 0.2374			6
0.003 0.007	7 0.2756	6.994 0.2754	10.98 0.4323	10.991 0.4327	10.98 0.4323	7.013 0.2761	7.033 0.2769			7
0.003 0.007	7 0.2756	6.994 0.2754	10.98 0.4323	10.991 0.4327	10.98 0.4323	7.013 0.2761	7.033 0.2769			7
0.003 0.007	8 0.315	7.994 0.3147	11.98 0.4717	11.991 0.4721	11.98 0.4717	8.013 0.3155	8.033 0.3163			8
0.003 0.007	8 0.315	7.994 0.3147	11.98 0.4717	11.991 0.4721	11.98 0.4717	8.013 0.3155	8.033 0.3163			8
0.004 0.009	8 0.315	7.994 0.3147	11.98 0.4717	11.991 0.4721	11.98 0.4717	8.013 0.3155	8.033 0.3163	0.0241	JR5x8x12	
0.004 0.009	8 0.315	7.994 0.3147	11.98 0.4717	11.991 0.4721	11.98 0.4717	8.013 0.3155	8.033 0.3163	0.0244	JR5x8x12	
0.004 0.009	9 0.3543	8.994 0.3541	12.98 0.511	12.991 0.5115	12.98 0.511	9.013 0.3548	9.033 0.3556	0.027	JR6x9x12	9
0.004 0.009	9 0.3543	8.994 0.3541	12.98 0.511	12.991 0.5115	12.98 0.511	9.013 0.3548	9.033 0.3556	0.027	JR6x9x12	
0.005 0.011	9 0.3543	8.994 0.3541	12.98 0.511	12.991 0.5115	12.98 0.511	9.013 0.3548	9.033 0.3556	0.0289	JR6x9x12	
0.005 0.011	9 0.3543	8.994 0.3541	12.98 0.511	12.991 0.5115	12.98 0.511	9.013 0.3548	9.033 0.3556	0.0289	JR6x9x12	
0.004 0.009	10 0.3937	9.994 0.3935	13.98 0.5504	13.991 0.5508	13.98 0.5504	10.013 0.3942	10.033 0.395	0.0287	JR7x10x10.5	10
0.004 0.009	10 0.3937	9.994 0.3935	13.98 0.5504	13.991 0.5508	13.98 0.5504	10.013 0.3942	10.033 0.395	0.0287	JR7x10x10.5	
0.005 0.011	10 0.3937	9.994 0.3935	13.98 0.5504	13.991 0.5508	13.98 0.5504	10.013 0.3942	10.033 0.395	0.0314	JR7x10x12	
0.005 0.011	10 0.3937	9.994 0.3935	13.98 0.5504	13.991 0.5508	13.98 0.5504	10.013 0.3942	10.033 0.395	0.0308	JR7x10x12	
0.007 0.015	10 0.3937	9.994 0.3935	13.98 0.5504	13.991 0.5508	13.98 0.5504	10.013 0.3942	10.033 0.395	0.0332	JR7x10x16	
0.006 0.013	12 0.4724	11.992 0.4721	15.98 0.6291	15.991 0.6296	17.98 0.7079	12.016 0.4731	12.036 0.4739	0.0319	JR8x12x10.5	12
0.006 0.013	12 0.4724	11.992 0.4721	15.98 0.6291	15.991 0.6296	17.98 0.7079	12.016 0.4731	12.036 0.4739	0.0319	JR8x12x10.5	
0.012 0.026	12 0.4724	11.992 0.4721	17.98 0.7079	17.991 0.7083	17.98 0.7079	12.016 0.4731	12.036 0.4739	0.0321	JR8x12x12.5	
0.01 0.022	12 0.4724	11.992 0.4721	17.98 0.7079	17.991 0.7083	17.98 0.7079	12.016 0.4731	12.036 0.4739	0.0321	JR8x12x12.5	
0.012 0.026	13 0.5118	12.992 0.5115	18.976 0.7471	18.989 0.7476	18.976 0.7471	13.016 0.5124	13.036 0.5132	0.0338	JR10x13x12.5	13
0.01 0.022	13 0.5118	12.992 0.5115	18.976 0.7471	18.989 0.7476	18.976 0.7471	13.016 0.5124	13.036 0.5132	0.0338	JR10x13x12.5	
0.014 0.031	14 0.5512	13.992 0.5509	19.976 0.7865	19.989 0.787	19.976 0.7865	14.016 0.5518	14.036 0.5526	0.0356	JR10x14x12	14

Continued on next page.



NEEDLE ROLLER BEARINGS

OPEN ENDS, CLOSED ONE END METRIC SERIES

continued

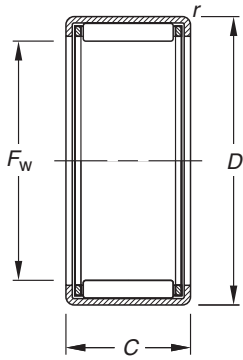

HK

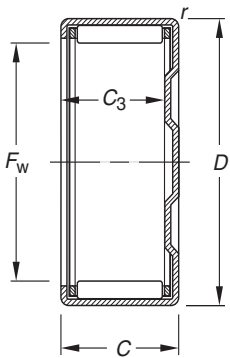

BK

Shaft Dia.	Dimensions mm/in.					Bearing Designation	Load Ratings kN/lbf.		Limiting Speed Approx.		C ₉
	mm	F _w	D	C	C _{3 min}		r _{s min}	Dynamic	Static	Grease	
	14	20	12	—	1	HK1412	7.21	8.5	14000	21000	0.0271
	0.5512	0.7874	0.472	—	0.039		1620	1910			
15	15	21	12	9.3	1	BK1512	7.16	8.57	14000	21000	0.0284
	0.5906	0.8268	0.472	0.366	0.039		1610	1930			
	15	21	12	—	1	HK1512	7.49	9.11	14000	21000	0.0284
	0.5906	0.8268	0.472	—	0.039		1680	2050			
	15	21	16	13.3	1	BK1516	10.7	14.4	14000	21000	0.0318
	0.5906	0.8268	0.63	0.524	0.039		2410	3240			
	15	21	16	—	1	HK1516	10.7	14.4	14000	21000	0.0318
	0.5906	0.8268	0.63	—	0.039		2410	3240			
	15	21	22	19.3	1	BK1522	13.5	19.4	14000	21000	0.0288
	0.5906	0.8268	0.866	0.76	0.039		3030	4360			
	15	21	22	—	1	HK1522	13.5	19.4	14000	21000	0.0288
	0.5906	0.8268	0.866	—	0.039		3030	4360			
16	16	22	12	9.3	1	BK1612	7.76	9.72	14000	21000	0.0297
	0.6299	0.8661	0.472	0.366	0.039		1740	2190			
	16	22	12	—	1	HK1612	7.76	7.72	14000	21000	0.0297
	0.6299	0.8661	0.472	—	0.039		1740	1740			
	16	22	16	13.3	1	BK1616	11.1	15.3	14000	21000	0.0332
	0.6299	0.8661	0.63	0.524	0.039		2500	3440			
	16	22	16	—	1	HK1616	11.1	15.3	14000	21000	0.0332
	0.6299	0.8661	0.63	—	0.039		2500	3440			
	16	22	22	19.3	1	BK1622	13.4	19.5	14000	21000	0.0297
	0.6299	0.8661	0.866	0.76	0.039		3010	4380			
	16	22	22	—	1	HK1622	13.4	19.5	14000	21000	0.0297
	0.6299	0.8661	0.866	—	0.039		3010	4380			
17	17	23	12	9.3	1	BK1712	8.12	10.4	13000	20000	0.0236
	0.6693	0.9055	0.472	0.366	0.039		1830	2340			
	17	23	12	—	1	HK1712	8.12	10.4	13000	20000	0.0236
	0.6693	0.9055	0.472	—	0.039		1830	2340			
18	18	24	12	—	1	HK1812	8.41	11.11	12000	18000	0.0246
	0.7087	0.9449	0.472	—	0.039		1890	2500			
	18	24	16	13.3	1	BK1816	11.6	16.8	12000	18000	0.0357
	0.7087	0.9449	0.63	0.524	0.039		2610	3780			
	18	24	16	—	1	HK1816	11.6	16.8	12000	18000	0.0357
	0.7087	0.9449	0.63	—	0.039		2610	3780			
20	20	26	12	9.3	1	BK2012	8.97	12.5	11000	16000	0.0347
	0.7874	1.0236	0.472	0.366	0.039		2020	2810			
	20	26	12	—	1	HK2012	8.97	12.5	11000	16000	0.0347
	0.7874	1.0236	0.472	—	0.039		2020	2810			
	20	26	16	13.3	1	BK2016	12.4	18.9	11000	16000	0.0385
	0.7874	1.0236	0.63	0.524	0.039		2790	4250			
	20	26	16	—	1	HK2016	12.4	18.9	11000	16000	0.0385
	0.7874	1.0236	0.63	—	0.039		2790	4250			
	20	26	20	17.3	1	BK2020	15.5	25.3	11000	16000	0.0414
	0.7874	1.0236	0.787	0.681	0.039		3480	5690			
	20	26	20	—	1	HK2020	15.9	26.2	11000	16000	0.0414
	0.7874	1.0236	0.787	—	0.039		3570	5890			
	20	26	30	27.3	1	BK2030	21.2	37.8	11000	16000	0.0385
	0.7874	1.0236	1.181	1.075	0.039		4770	8500			
	20	26	30	—	1	HK2030	21.2	37.8	11000	16000	0.0385
	0.7874	1.0236	1.181	—	0.039		4770	8500			
22	22	28	12	9.3	1	BK2212	9.81	14.5	9600	15000	0.0375
	0.8661	1.1024	0.472	0.366	0.039		2210	3260			
	22	28	12	—	1	HK2212	9.81	14.5	9600	15000	0.0382
	0.8661	1.1024	0.472	—	0.039		2210	3260			
	22	28	16	13.3	1	BK2216	13.1	20.9	9600	15000	0.0412
	0.8661	1.1024	0.63	0.524	0.039		2940	4700			

Wt. kg/lbs	Mounting Dimensions mm/in.						Plug Gage		Matching Inner Ring	Shaft Dia. mm
	Max.	Min.	Min.	Max.	Ring Gage	Go	No-Go			
	S		H			C _g				
0.011 0.024	14 0.5512	13.992 0.5509	19.976 0.7865	19.989 0.787	19.976 0.7865	14.016 0.5518	14.036 0.5526	0.0356	JR10x14x12	
0.015 0.033	15 0.5906	14.992 0.5902	20.976 0.8258	20.989 0.8263	20.976 0.8258	15.016 0.5912	15.036 0.592	0.0373	JR12x15x12.5	15
0.011 0.024	15 0.5906	14.992 0.5902	20.976 0.8258	20.989 0.8263	20.976 0.8258	15.016 0.5912	15.036 0.592	0.0373	JR12x15x12.5	
0.019 0.042	15 0.5906	14.992 0.5902	20.976 0.8258	20.989 0.8263	20.976 0.8258	15.016 0.5912	15.036 0.592	0.0417	JR12x15x16.5	
0.016 0.035	15 0.5906	14.992 0.5902	20.976 0.8258	20.989 0.8263	20.976 0.8258	15.016 0.5912	15.036 0.592	0.0417	JR12x15x16.5	
0.025 0.055	15 0.5906	14.992 0.5902	20.976 0.8258	20.989 0.8263	20.976 0.8258	15.016 0.5912	15.036 0.592	0.0378	JR12x15x22.5	
0.024 0.053	15 0.5906	14.992 0.5902	20.976 0.8258	20.989 0.8263	20.976 0.8258	15.016 0.5912	15.036 0.592	0.0378	JR12x15x22.5	
0.016 0.035	16 0.6299	15.992 0.6296	21.976 0.8652	21.989 0.8657	21.976 0.8652	16.016 0.6306	16.036 0.6313	0.039	JR12x16x12	16
0.012 0.026	16 0.6299	15.992 0.6296	21.976 0.8652	21.989 0.8657	21.976 0.8652	16.016 0.6306	16.036 0.6313	0.039	JR12x16x12	
0.02 0.044	16 0.6299	15.992 0.6296	21.976 0.8652	21.989 0.8657	21.976 0.8652	16.016 0.6306	16.036 0.6313	0.0436	JR12x16x16	
0.018 0.04	16 0.6299	15.992 0.6296	21.976 0.8652	21.989 0.8657	21.976 0.8652	16.016 0.6306	16.036 0.6313	0.0436	JR12x16x16	
0.028 0.062	16 0.6299	15.992 0.6296	21.976 0.8652	21.989 0.8657	21.976 0.8652	16.016 0.6306	16.036 0.6313	0.039	JR12x16x22	
0.022 0.049	16 0.6299	15.992 0.6296	21.976 0.8652	21.989 0.8657	21.976 0.8652	16.016 0.6306	16.036 0.6313	0.039	JR12x16x22	
0.018 0.04	17 0.6693	16.992 0.669	22.976 0.9046	22.989 0.9051	22.976 0.9046	17.016 0.6699	17.036 0.6707			17
0.013 0.029	17 0.6693	16.992 0.669	22.976 0.9046	22.989 0.9051	22.976 0.9046	17.016 0.6699	17.036 0.6707			
0.015 0.033	18 0.7087	17.992 0.7083	23.976 0.9439	23.989 0.9444	23.976 0.9439	18.016 0.7093	18.036 0.7101			18
0.022 0.049	18 0.7087	17.992 0.7083	23.976 0.9439	23.989 0.9444	23.976 0.9439	18.016 0.7093	18.036 0.7101	0.0468	JR15x18x16.5	
0.018 0.04	18 0.7087	17.992 0.7083	23.976 0.9439	23.989 0.9444	23.976 0.9439	18.016 0.7093	18.036 0.7101	0.0468	JR15x18x16.5	
0.017 0.037	20 0.7874	19.991 0.787	25.976 1.0227	25.989 1.0232	25.976 1.0227	20.02 0.7882	20.043 0.7891	0.0455	JR15x20x12	20
0.016 0.035	20 0.7874	19.991 0.787	25.976 1.0227	25.989 1.0232	25.976 1.0227	20.02 0.7882	20.043 0.7891	0.0455	JR15x20x12	
0.022 0.049	20 0.7874	19.991 0.787	25.976 1.0227	25.989 1.0232	25.976 1.0227	20.02 0.7882	20.043 0.7891	0.0505	JR17x20x16.5	
0.022 0.049	20 0.7874	19.991 0.787	25.976 1.0227	25.989 1.0232	25.976 1.0227	20.02 0.7882	20.043 0.7891	0.0505	JR17x20x16.5	
0.027 0.06	20 0.7874	19.991 0.787	25.976 1.0227	25.989 1.0232	25.976 1.0227	20.02 0.7882	20.043 0.7891	0.0543	JR17x20x20.5	
0.025 0.055	20 0.7874	19.991 0.787	25.976 1.0227	25.989 1.0232	25.976 1.0227	20.02 0.7882	20.043 0.7891	0.0543	JR17x20x20.5	
0.043 0.095	20 0.7874	19.991 0.787	25.976 1.0227	25.989 1.0232	25.976 1.0227	20.02 0.7882	20.043 0.7891	0.0505	JR17x20x30.5	
0.041 0.09	20 0.7874	19.991 0.787	25.976 1.0227	25.989 1.0232	25.976 1.0227	20.02 0.7882	20.043 0.7891	0.0505	JR17x20x30.5	
0.02 0.044	22 0.8661	21.991 0.8658	27.976 1.1014	27.989 1.1019	27.976 1.1014	22.02 0.8669	22.043 0.8678	0.0492	JR17x22x13	22
0.015 0.033	22 0.8661	21.991 0.8658	27.976 1.1014	27.989 1.1019	27.976 1.1014	22.02 0.8669	22.043 0.8678	0.0501	JR17x22x13	
0.027 0.06	22 0.8661	21.991 0.8658	27.976 1.1014	27.989 1.1019	27.976 1.1014	22.02 0.8669	22.043 0.8678	0.0541	JR17x22x16	

Continued on next page.



NEEDLE ROLLER BEARINGS

OPEN ENDS, CLOSED ONE END METRIC SERIES

continued

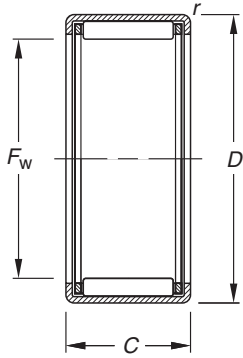

HK

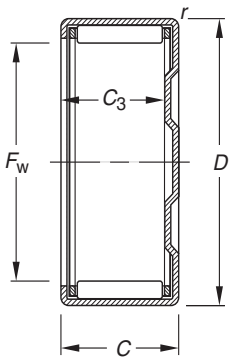

BK

Shaft Dia.	Dimensions mm/in.					Bearing Designation	Load Ratings kN/lbf.		Limiting Speed Approx.		C ₉
	mm	F _w	D	C	C _{3 min}		r _{s min}	Dynamic	Static	Grease	
	22	28	16	—	1	HK2216	13.1	20.9	9600	15000	0.0412
	0.8661	1.1024	0.63	—	0.039		2940	4700			
	22	28	20	17.3	1	BK2220	15.3	25.5	9600	15000	0.0432
	0.8661	1.1024	0.787	0.681	0.039		3440	5730			
	22	28	20	—	1	HK2220	15.3	25.5	9600	15000	0.0432
	0.8661	1.1024	0.787	—	0.039		3440	5730			
25	25	32	12	—	1	HK2512	10.9	14.7	8500	13000	0.0295
	0.9843	1.2598	0.472	—	0.039		2450	3300			
	25	32	16	13.3	1	BK2516	15.6	23.5	8500	13000	0.0434
	0.9843	1.2598	0.63	0.524	0.039		3510	5280			
	25	32	16	—	1	HK2516	15.6	23.5	8500	13000	0.0434
	0.9843	1.2598	0.63	—	0.039		3510	5280			
	25	32	20	17.3	1	BK2520	20.6	33.4	8500	13000	0.0474
	0.9843	1.2598	0.787	0.681	0.039		4630	7510			
	25	32	20	—	1	HK2520	20.6	33.4	8500	13000	0.0474
	0.9843	1.2598	0.787	—	0.039		4630	7510			
	25	32	26	23.3	1	BK2526	25.7	44.4	8500	13000	0.0508
	0.9843	1.2598	1.024	0.917	0.039		5780	9980			
	25	32	26	—	1	HK2526	25.7	44.4	8500	13000	0.0508
	0.9843	1.2598	1.024	—	0.039		5780	9980			
	25	32	38	35.3	1	BK2538	35.3	66.9	8500	13000	0.0474
	0.9843	1.2598	1.496	1.39	0.039		7940	15000			
	25	32	38	—	1	HK2538	35.3	66.9	8500	13000	0.0474
	0.9843	1.2598	1.496	—	0.039		7940	15000			
28	28	35	16	—	1	HK2816	15.9	24.9	7500	12000	0.0462
	1.1024	1.378	0.63	—	0.039		3570	5600			
	28	35	20	17.3	1	BK2820	20.9	35.3	7500	12000	0.0504
	1.1024	1.378	0.787	0.681	0.039		4700	7940			
	28	35	20	—	1	HK2820	20.9	35.3	7500	12000	0.0504
	1.1024	1.378	0.787	—	0.039		4700	7940			
30	30	37	12	9.3	1	BK3012	11.6	16.8	7000	11000	0.033
	1.1811	1.4567	0.472	0.366	0.039		2610	3780			
	30	37	12	—	1	HK3012	12	17.7	7000	11000	0.033
	1.1811	1.4567	0.472	—	0.039		2700	3980			
	30	37	16	—	1	HK3016	16.8	27.3	7000	11000	0.0488
	1.1811	1.4567	0.63	—	0.039		3780	6140			
	30	37	20	17.3	1	BK3020	22.4	39.6	7000	11000	0.0537
	1.1811	1.4567	0.787	0.681	0.039		5040	8900			
	30	37	20	—	1	HK3020	22.4	39.6	7000	11000	0.0537
	1.1811	1.4567	0.787	—	0.039		5040	8900			
	30	37	26	23.3	1	BK3026	27.4	51.2	7000	11000	0.057
	1.1811	1.4567	1.024	0.917	0.039		6160	11500			
	30	37	26	—	1	HK3026	27.4	51.2	7000	11000	0.0571
	1.1811	1.4567	1.024	—	0.039		6160	11500			
	30	37	38	35.3	1	BK3038	38.4	79.2	7000	11000	0.0535
	1.1811	1.4567	1.496	1.39	0.039		8630	17800			
	30	37	38	—	1	HK3038	38.4	79.2	7000	11000	0.0535
	1.1811	1.4567	1.496	—	0.039		8630	17800			
35	35	42	12	—	1	HK3512	13	20.6	5900	9100	0.0365
	1.378	1.6535	0.472	—	0.039		2920	4630			
	35	42	16	—	1	HK3516	17.4	29.9	5900	9100	0.0534
	1.378	1.6535	0.63	—	0.039		3910	6720			
	35	42	20	17.3	1	BK3520	24.5	46.8	5900	9100	0.0597
	1.378	1.6535	0.787	0.681	0.039		5510	10520			
	35	42	20	—	1	HK3520	24.5	46.8	5900	9100	0.0597
	1.378	1.6535	0.787	—	0.039		5510	10500			
40	40	47	12	—	1	HK4012	14.7	25.3	5200	7900	0.0402
	1.5748	1.8504	0.472	—	0.039		3300	5690			

Wt. kg/lbs	Mounting Dimensions mm/in.						Plug Gage		Matching Inner Ring	Shaft Dia. mm
	Max.	Min.	Min.	Max.	Ring Gage	Go	No-Go			
	S		H			C _g				
0.022 0.049	22 0.8661	21.991 0.8658	27.976 1.1014	27.989 1.1019	27.976 1.1014	22.02 0.8669	22.043 0.8678	0.0541	JR17x22x16	
0.028 0.062	22 0.8661	21.991 0.8658	27.976 1.1014	27.989 1.1019	27.976 1.1014	22.02 0.8669	22.043 0.8678	0.0567	JR17x22x23	
0.026 0.057	22 0.8661	21.991 0.8658	27.976 1.1014	27.989 1.1019	27.976 1.1014	22.02 0.8669	22.043 0.8678	0.0567	JR17x22x23	
0.021 0.046	25 0.9843	24.991 0.9839	31.972 1.2587	31.988 1.2594	31.972 1.2587	25.02 0.985	25.043 0.9859			25
0.031 0.068	25 0.9843	24.991 0.9839	31.972 1.2587	31.988 1.2594	31.972 1.2587	25.02 0.985	25.043 0.9859	0.0569	JR20x25x17	
0.028 0.062	25 0.9843	24.991 0.9839	31.972 1.2587	31.988 1.2594	31.972 1.2587	25.02 0.985	25.043 0.9859	0.0569	JR20x25x17	
0.043 0.095	25 0.9843	24.991 0.9839	31.972 1.2587	31.988 1.2594	31.972 1.2587	25.02 0.985	25.043 0.9859	0.0622	JR20x25x20.5	
0.04 0.088	25 0.9843	24.991 0.9839	31.972 1.2587	31.988 1.2594	31.972 1.2587	25.02 0.985	25.043 0.9859	0.0622	JR20x25x20.5	
0.048 0.106	25 0.9843	24.991 0.9839	31.972 1.2587	31.988 1.2594	31.972 1.2587	25.02 0.985	25.043 0.9859	0.0666	JR20x25x26.5	
0.046 0.101	25 0.9843	24.991 0.9839	31.972 1.2587	31.988 1.2594	31.972 1.2587	25.02 0.985	25.043 0.9859	0.0666	JR20x25x26.5	
0.077 0.17	25 0.9843	24.991 0.9839	31.972 1.2587	31.988 1.2594	31.972 1.2587	25.02 0.985	25.043 0.9859	0.0622	JR20x25x38.5	
0.073 0.161	25 0.9843	24.991 0.9839	31.972 1.2587	31.988 1.2594	31.972 1.2587	25.02 0.985	25.043 0.9859	0.0622	JR20x25x38.5	
0.032 0.071	28 1.1024	27.991 1.102	34.972 1.3769	34.988 1.3775	34.972 1.3769	28.02 1.1031	28.043 1.1041	0.0606	JR22x28x17	28
0.047 0.104	28 1.1024	27.991 1.102	34.972 1.3769	34.988 1.3775	34.972 1.3769	28.02 1.1031	28.043 1.1041	0.0661	JR22x28x20.5	
0.04 0.088	28 1.1024	27.991 1.102	34.972 1.3769	34.988 1.3775	34.972 1.3769	28.02 1.1031	28.043 1.1041	0.0661	JR22x28x20.5	
0.031 0.068	30 1.1811	29.991 1.1807	36.972 1.4556	36.988 1.4562	36.972 1.4556	30.02 1.1819	30.043 1.1828			30
0.042 0.093	30 1.1811	29.991 1.1807	36.972 1.4556	36.988 1.4562	36.972 1.4556	30.02 1.1819	30.043 1.1828			
0.032 0.071	30 1.1811	29.991 1.1807	36.972 1.4556	36.988 1.4562	36.972 1.4556	30.02 1.1819	30.043 1.1828	0.064	JR25x30x17	
0.053 0.117	30 1.1811	29.991 1.1807	36.972 1.4556	36.988 1.4562	36.972 1.4556	30.02 1.1819	30.043 1.1828	0.0705	JR25x30x20.5	
0.047 0.104	30 1.1811	29.991 1.1807	36.972 1.4556	36.988 1.4562	36.972 1.4556	30.02 1.1819	30.043 1.1828	0.0705	JR25x30x20.5	
0.067 0.148	30 1.1811	29.991 1.1807	36.972 1.4556	36.988 1.4562	36.972 1.4556	30.02 1.1819	30.043 1.1828	0.0748	JR25x30x26.5	
0.052 0.115	30 1.1811	29.991 1.1807	36.972 1.4556	36.988 1.4562	36.972 1.4556	30.02 1.1819	30.043 1.1828	0.0749	JR25x30x26.5	
0.093 0.205	30 1.1811	29.991 1.1807	36.972 1.4556	36.988 1.4562	36.972 1.4556	30.02 1.1819	30.043 1.1828	0.0702	JR25x30x38.5	
0.087 0.192	30 1.1811	29.991 1.1807	36.972 1.4556	36.988 1.4562	36.972 1.4556	30.02 1.1819	30.043 1.1828	0.0702	JR25x30x38.5	
0.028 0.062	35 1.378	34.989 1.3775	41.972 1.6524	41.988 1.6531	41.972 1.6524	35.025 1.3789	35.052 1.38			35
0.037 0.082	35 1.378	34.989 1.3775	41.972 1.6524	41.988 1.6531	41.972 1.6524	35.025 1.3789	35.052 1.38	0.0701	JR30x35x17	
0.065 0.143	35 1.378	34.989 1.3775	41.972 1.6524	41.988 1.6531	41.972 1.6524	35.025 1.3789	35.052 1.38	0.0783	JR30x35x20.5	
0.049 0.108	35 1.378	34.989 1.3775	41.972 1.6524	41.988 1.6531	41.972 1.6524	35.025 1.3789	35.052 1.38	0.0783	JR30x35x20.5	
0.036 0.079	40 1.5748	39.989 1.5744	46.972 1.8493	46.988 1.8499	46.972 1.8493	40.025 1.5758	40.052 1.5769			40

Continued on next page.



NEEDLE ROLLER BEARINGS

OPEN ENDS, CLOSED ONE END

METRIC SERIES

continued

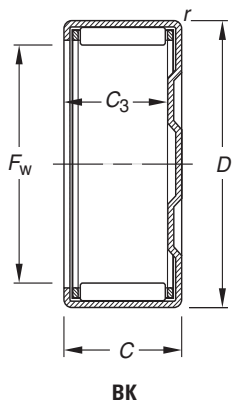
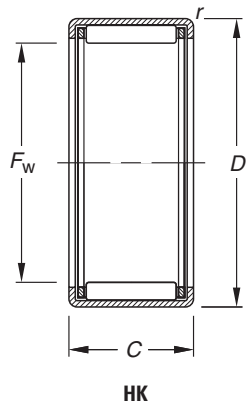

Shaft Dia.	Dimensions mm/in.					Bearing Designation	Load Ratings kN/lbf.		Limiting Speed Approx.		C _g
	-0.3, -.012						Dynamic	Static	Grease	Oil	
mm	F _w	D	C	C _{3 min}	r _{s min}		C	C ₀	RPM		
40	40	47	16	—	1	HK4016	18.9	34.8	5200	7900	0.0589
	1.5748	1.8504	0.63		0.039		4250	7820			
40	40	47	20	17.3	1	BK4020	25.1	50.4	5200	7900	0.0646
	1.5748	1.8504	0.787	0.681	0.039		5640	11300			
40	40	47	20	—	1	HK4020	25.1	50.4	5200	7900	0.0646
	1.5748	1.8504	0.787		0.039		5640	11300			
45	45	52	12	—	1	HK4512	14.1	24.8	4600	7000	N/A
	1.7717	2.0472	0.472		0.039		3170	5580			
45	45	52	16	—	1	HK4516	19.8	38.5	4600	7000	0.0637
	1.7717	2.0472	0.63		0.039		4450	8660			
45	45	52	20	17.3	1	BK4520	26.3	55.4	4600	7000	0.0697
	1.7717	2.0472	0.787	0.681	0.039		5910	12500			
45	45	52	20	—	1	HK4520	27.2	58.2	4600	7000	0.0697
	1.7717	2.0472	0.787		0.039		6110	13100			
50	50	58	20	—	1	HK5020	30.9	62.2	4100	6300	0.0714
	1.9685	2.2835	0.787		0.039		6950	14000			
50	50	58	25	—	1	HK5025	35.5	74.1	4100	6300	0.0764
	1.9685	2.2835	0.984		0.039		7980	16700			
60	60	68	12	—	1	HK6012	17.2	31.2	3400	5200	0.0523
	2.3622	2.6772	0.472		0.039		3870	7010			

Wt. kg/lbs	Mounting Dimensions mm/in.					Plug Gage		C _g	Matching Inner Ring	Shaft Dia. mm
	Max.	Min.	Min.	Max.	Ring Gage	Go	No-Go			
	S		H							
0.048 0.106	40 1.5748	39.989 1.5744	46.972 1.8493	46.988 1.8499	46.972 1.8493	40.025 1.5758	40.052 1.5769	0.0773	JR35x40x17	
0.07 0.154	40 1.5748	39.989 1.5744	46.972 1.8493	46.988 1.8499	46.972 1.8493	40.025 1.5758	40.052 1.5769	0.0848	JR35x40x20.5	
0.06 0.132	40 1.5748	39.989 1.5744	46.972 1.8493	46.988 1.8499	46.972 1.8493	40.025 1.5758	40.052 1.5769	0.0848	JR35x40x20.5	
0.036 0.079	45 1.7717	44.989 1.7712	51.967 2.0459	51.986 2.0467	51.967 2.0459	45.025 1.7726	45.052 1.7737	N/A		45
0.048 0.106	45 1.7717	44.989 1.7712	51.967 2.0459	51.986 2.0467	51.967 2.0459	45.025 1.7726	45.052 1.7737	0.0836	JR40x45x17	
0.079 0.174	45 1.7717	44.989 1.7712	51.967 2.0459	51.986 2.0467	51.967 2.0459	45.025 1.7726	45.052 1.7737	0.0914	JR40x45x20.5	
0.057 0.126	45 1.7717	44.989 1.7712	51.967 2.0459	51.986 2.0467	51.967 2.0459	45.025 1.7726	45.052 1.7737	0.0914	JR40x45x20.5	
0.072 0.159	50 1.9685	49.989 1.9681	57.967 2.2822	57.986 2.2829	57.967 2.2822	50.025 1.9695	50.052 1.9706	0.0937	JR45x50x20	
0.092 0.203	50 1.9685	49.989 1.9681	57.967 2.2822	57.986 2.2829	57.967 2.2822	50.025 1.9695	50.052 1.9706	0.1002	JR45x50x25.5	50
0.06 0.132	60 2.3622	59.987 2.3617	67.967 2.6759	67.986 2.6766	67.967 2.6759	60.03 2.3634	60.062 2.3646			





NEEDLE ROLLER BEARINGS

SEALED BEARINGS METRIC SERIES

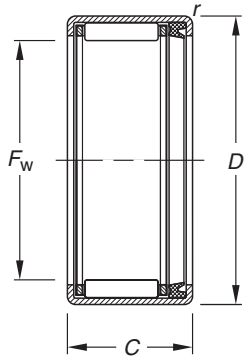

HK RS

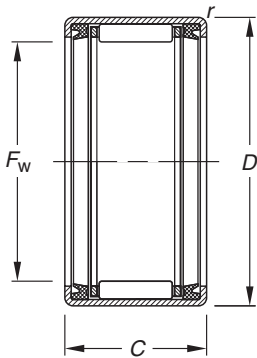

HK .2RS

Shaft Dia.	Dimensions mm/in.					Bearing Designation	Load Ratings kN/lbf.		Limiting Speed Approx. Grease RPM	C ₉
	F _w	D	C	C _{3 min}	r _{s min}		C	C ₀		
8	8 0.315	12 0.4724	10 0.394	—	0.4 0.016	HK0810RS	2.9 650	2.73 610	20000	N/A
10	10 0.3937	14 0.5512	12 0.472	—	0.4 0.016	HK1012RS	4.78 1070	5.51 1240	19000	N/A
12	12 0.4724	18 0.7087	14 0.551	—	1 0.039	HK1214RS	6.61 1490	7.29 1640	14000	0.0189
	12 0.4724	18 0.7087	16 0.63	—	1	HK1216.2RS	6.87	7.65	14000	0.0189
14	14 0.5512	20 0.7874	14 0.551	11.3 0.445	1 0.039	BK1414RS	7.17 1610	8.41 1890	14000	N/A
	14 0.5512	20 0.7874	14 0.551	—	1 0.039	HK1414RS	7.17 1610	8.41 1890	14000	0.0271
	14 0.5512	20 0.7874	16 0.63	—	1 0.039	HK1416.2RS	7.17 1610	8.41 1890	14000	0.0271
15	15 0.5906	21 0.8268	14 0.551	11.3 0.445	1 0.039	BK1514RS	7.87 1770	9.69 2180	13000	N/A
	15 0.5906	21 0.8268	14 0.551	—	1 0.039	HK1514RS	7.87 1770	9.69 2180	13000	0.0288
	15 0.5906	21 0.8268	16 0.63	—	1 0.039	HK1516.2RS	7.87 1770	9.69 2180	13000	0.0288
16	16 0.6299	22 0.8661	16 0.63	—	1 0.039	HK1614RS	7.82 1760	9.76 2190	12000	0.0297
	16 0.6299	22 0.8661	16 0.63	—	1 0.039	HK1616.2RS	7.82 1760	9.76 2190	12000	0.0297
18	18 0.7087	24 0.9449	14 0.551	—	1 0.039	HK1814RS	8.41 1890	11.1 2500	11000	0.0246
	18 0.7087	24 0.9449	16 0.63	—	1 0.039	HK1816.2RS	8.41 1890	11.1 2500	11000	0.0322
20	20 0.7874	26 1.0236	16 0.63	—	1 0.039	HK2016.2RS	8.97 2020	12.5 2810	9700	0.0347
	20 0.7874	26 1.0236	18 0.709	—	1 0.039	HK2018RS	12.4 2790	18.9 4250	9700	0.0385
	20 0.7874	26 1.0236	20 0.787	—	1 0.039	HK2020.2RS	12.4 2790	18.9 4250	9700	0.0385
22	22 0.8661	28 1.1024	16 0.63	—	1 0.039	HK2216.2RS	9.81 2210	14.5 3260	8800	0.0286
22	22 0.8661	28 1.1024	18 0.709	—	1 0.039	HK2218RS	13.1 2950	20.9 4700	8800	0.0412
	22 0.8661	28 1.1024	20 0.787	—	1 0.039	HK2220.2RS	13.1 2950	20.9 4700	8800	0.0412
25	25 0.9843	32 1.2598	16 0.63	—	1 0.039	HK2516.2RS	11.1 2500	15.1 3390	7800	0.0389
	25 0.9843	32 1.2598	18 0.709	—	1 0.039	HK2518RS	16.2 3640	24.6 5530	7800	0.0439
	25 0.9843	32 1.2598	20 0.787	—	1 0.039	HK2520.2RS	16.2 3640	24.6 5530	7800	0.0439
	25 0.9843	32 1.2598	22 0.866	—	1 0.039	HK2522RS	20.6 4630	33.4 7510	7800	0.0474
	25 0.9843	32 1.2598	24 0.945	—	1 0.039	HK2524.2RS	20.6 4630	33.4 7510	7800	0.0474
28	28 1.1024	35 1.378	20 0.787	—	1 0.039	HK2820.2RS	15.9 3570	24.9 5600	6900	0.0462
30	30 1.1811	37 1.4567	16 0.63	—	1 0.039	HK3016.2RS	11.6 2610	16.8 3780	6500	0.0432
	30 1.1811	37 1.4567	18 0.709	—	1 0.039	HK3018RS	16.8 3780	27.3 6140	6500	0.0488
	30 1.1811	37 1.4567	20 0.787	—	1 0.039	HK3020.2RS	16.8 3780	27.3 6140	6500	0.0488

Wt. kg/lbs	Mounting Dimensions mm/in.						Plug Gage		Matching Inner Ring	Shaft Dia. mm
	Max.	Min.	Min.	Max.	Ring Gage	Go	No-Go			
	S		H			C _g				
0.004 0.009	8 0.315	7.994 0.3147	11.98 0.4717	11.991 0.4721	11.98 0.4717	8.013 0.3155	8.033 0.3163		8	
0.005 0.011	10 0.3937	9.994 0.3935	13.98 0.5504	13.991 0.5508	13.98 0.5504	10.013 0.3942	10.033 0.395		10	
0.013 0.029	12 0.4724	11.992 0.4721	17.98 0.7079	17.991 0.7083	17.98 0.7079	12.016 0.4731	12.036 0.4739		12	
0.016 0.035	12 0.4724	11.992 0.4721	17.98 0.7079	17.991 0.7083	17.98 0.7079	12.016 0.4731	12.036 0.4739			
0.014 0.031	14 0.5512	13.992 0.5509	19.976 0.7865	19.989 0.787	19.976 0.7865	14.016 0.5518	14.036 0.5526		14	
0.015 0.033	14 0.5512	13.992 0.5509	19.976 0.7865	19.989 0.787	19.976 0.7865	14.016 0.5518	14.036 0.5526	0.0356	JR10x14x16	
0.014 0.031	14 0.5512	13.992 0.5509	19.976 0.7865	19.989 0.787	19.976 0.7865	14.016 0.5518	14.036 0.5526	0.0356	JR10x14x20	
0.017 0.037	15 0.5906	14.992 0.5902	20.976 0.8258	20.989 0.8263	20.976 0.8258	15.016 0.5912	15.036 0.592	0.0378	JR12x15x16.5	
0.016 0.035	15 0.5906	14.992 0.5902	20.976 0.8258	20.989 0.8263	20.976 0.8258	15.016 0.5912	15.036 0.592	0.0378	JR12x15x16.5	
0.019 0.042	15 0.5906	14.992 0.5902	20.976 0.8258	20.989 0.8263	20.976 0.8258	15.016 0.5912	15.036 0.592	0.0378	JR12x15x16.5	
0.014 0.031	16 0.6299	15.992 0.6296	21.976 0.8652	21.989 0.8657	21.976 0.8652	16.016 0.6306	16.036 0.6313	0.039	JR12x16x16	
0.015 0.033	16 0.6299	15.992 0.6296	21.976 0.8652	21.989 0.8657	21.976 0.8652	16.016 0.6306	16.036 0.6313	0.039	JR12x16x20	
0.018 0.04	18 0.7087	17.992 0.7083	23.976 0.9439	23.989 0.9444	23.976 0.9439	18.016 0.7093	18.036 0.7101		18	
0.017 0.037	18 0.7087	17.992 0.7083	23.976 0.9439	23.989 0.9444	23.976 0.9439	18.016 0.7093	18.036 0.7101	0.0422	JR15x18x16.5	
0.023 0.051	20 0.7874	19.991 0.787	25.976 1.0227	25.989 1.0232	25.976 1.0227	20.02 0.7882	20.043 0.7891	0.0455	JR17x20x16.5	
0.025 0.055	20 0.7874	19.991 0.787	25.976 1.0227	25.989 1.0232	25.976 1.0227	20.02 0.7882	20.043 0.7891	0.0505	JR17x20x20.5	
0.028 0.062	20 0.7874	19.991 0.787	25.976 1.0227	25.989 1.0232	25.976 1.0227	20.02 0.7882	20.043 0.7891	0.0505	JR17x20x20.5	
0.025 0.055	22 0.8661	21.991 0.8658	27.976 1.1014	27.989 1.1019	27.976 1.1014	22.02 0.8669	22.043 0.8678		22	
0.027 0.06	22 0.8661	21.991 0.8658	27.976 1.1014	27.989 1.1019	27.976 1.1014	22.02 0.8669	22.043 0.8678	0.0541	JR17x22x23	
0.026 0.057	22 0.8661	21.991 0.8658	27.976 1.1014	27.989 1.1019	27.976 1.1014	22.02 0.8669	22.043 0.8678	0.0541	JR17x22x23	
0.03 0.066	25 0.9843	24.991 0.9839	31.972 1.2587	31.988 1.2594	31.972 1.2587	25.02 0.985	25.043 0.9859	0.051	JR20x25x17	
0.034 0.075	25 0.9843	24.991 0.9839	31.972 1.2587	31.988 1.2594	31.972 1.2587	25.02 0.985	25.043 0.9859	0.0576	JR20x25x20.5	
0.038 0.084	25 0.9843	24.991 0.9839	31.972 1.2587	31.988 1.2594	31.972 1.2587	25.02 0.985	25.043 0.9859	0.0576	JR20x25x20.5	
0.042 0.093	25 0.9843	24.991 0.9839	31.972 1.2587	31.988 1.2594	31.972 1.2587	25.02 0.985	25.043 0.9859	0.0622	JR20x25x26	
0.047 0.104	25 0.9843	24.991 0.9839	31.972 1.2587	31.988 1.2594	31.972 1.2587	25.02 0.985	25.043 0.9859	0.0622	JR20x25x26	
0.042 0.093	28 1.1024	27.991 1.102	34.972 1.3769	34.988 1.3775	34.972 1.3769	28.02 1.1031	28.043 1.1041	0.0606	JR22x28x20.5	
0.03 0.066	30 1.1811	29.991 1.1807	36.972 1.4556	36.988 1.4562	36.972 1.4556	30.02 1.1819	30.043 1.1828	0.0567	JR25x30x17	
0.042 0.093	30 1.1811	29.991 1.1807	36.972 1.4556	36.988 1.4562	36.972 1.4556	30.02 1.1819	30.043 1.1828	0.064	JR25x30x20.5	
0.04 0.088	30 1.1811	29.991 1.1807	36.972 1.4556	36.988 1.4562	36.972 1.4556	30.02 1.1819	30.043 1.1828	0.064	JR25x30x20.5	

Continued on next page.



SEALED BEARINGS METRIC SERIES

continued

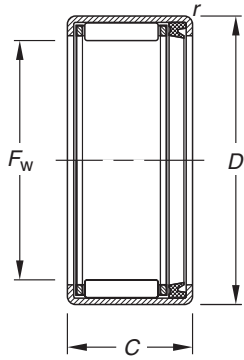

HK RS

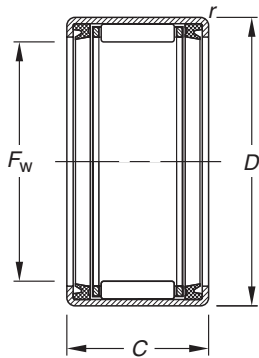

HK .2RS

Shaft Dia.	Dimensions mm/in.					Bearing Designation	Load Ratings kN/lbf.		Limiting Speed Approx. Grease RPM	C _g
	-0.3 -.012						Dynamic	Static		
mm	F _w	D	C	C _{3 min}	r _{s min}		C	C ₀		
30	30	37	22	—	1	HK3022RS	22.4	39.6	6500	0.0535
	1.1811	1.4567	0.866		0.039		5040	8900		
30	30	37	24	—	1	HK3024.2RS	22.4	39.6	6500	0.0535
	1.1811	1.4567	0.945		0.039		5040	8900		
35	35	42	16	—	1	HK3516.2RS	14.2	23.2	5500	0.0492
	1.378	1.6535	0.63		0.039		3190	5220		
35	35	42	18	—	1	HK3518RS	17.4	29.9	5500	0.0534
	1.378	1.6535	0.709		0.039		3910	6720		
35	35	42	20	—	1	HK3520.2RS	17.4	29.9	5500	0.0534
	1.378	1.6535	0.787		0.039		3910	6720		
40	40	47	16	—	1	HK4016.2RS	13.4	22.4	4900	0.0528
	1.5748	1.8504	0.63		0.039		3010	5040		
40	40	47	18	—	1	HK4018RS	18.9	34.8	4900	0.0589
	1.5748	1.8504	0.709		0.039		4250	7820		
40	40	47	20	—	1	HK4020.2RS	18.9	34.8	4900	0.0589
	1.5748	1.8504	0.787		0.039		4250	7820		
45	45	52	18	—	1	HK4518RS	19.8	38.5	4300	0.0637
	1.7717	2.0472	0.709		0.039		4450	8660		
45	45	52	20	—	1	HK4520.2RS	19.8	38.5	4300	0.0637
	1.7717	2.0472	0.787		0.039		4450	8660		
50	50	58	22	—	1	HK5022RS	28.8	56.6	3900	0.0714
	1.9685	2.2835	0.866		0.039		6470	12700		
50	50	58	24	—	1	HK5024.2RS	28.8	56.6	3900	0.0714
	1.9685	2.2835	0.945		0.039		6470	12700		

Wt. kg/lbs.	Mounting Dimensions mm/in.					Plug Gage		C _g	Matching Inner Ring	Shaft Dia. mm
	Max.	Min.	Min.	Max.	Ring Gage	Go	No-Go			
	S		H							
0.051 0.112	30 1.1811	29.991 1.1807	36.972 1.4556	36.988 1.4562	36.972 1.4556	30.02 1.1819	30.043 1.1828	0.0702	JR25x30x26	
0.057 0.126	30 1.1811	29.991 1.1807	36.972 1.4556	36.988 1.4562	36.972 1.4556	30.02 1.1819	30.043 1.1828	0.0702	JR25x30x26	
0.047 0.104	35 1.378	34.989 1.3775	41.972 1.6524	41.988 1.6531	41.972 1.6524	35.025 1.3789	35.052 1.38	0.0646	JR30x35x17	35
0.54 1.19	35 1.378	34.989 1.3775	41.972 1.6524	41.988 1.6531	41.972 1.6524	35.025 1.3789	35.052 1.38	0.0701	JR30x35x20.5	
0.044 0.097	35 1.378	34.989 1.3775	41.972 1.6524	41.988 1.6531	41.972 1.6524	35.025 1.3789	35.052 1.38	0.0701	JR30x35x20.5	
0.037 0.082	40 1.5748	39.989 1.5744	46.972 1.8493	46.988 1.8499	46.972 1.8493	40.025 1.5758	40.052 1.5769	0.0693	JR35x40x20	40
0.057 0.126	40 1.5748	39.989 1.5744	46.972 1.8493	46.988 1.8499	46.972 1.8493	40.025 1.5758	40.052 1.5769	0.0773	JR35x40x20.5	
0.053 0.117	40 1.5748	39.989 1.5744	46.972 1.8493	46.988 1.8499	46.972 1.8493	40.025 1.5758	40.052 1.5769	0.0773	JR35x40x20.5	
0.064 0.141	45 1.7717	44.989 1.7712	51.967 2.0459	51.986 2.0467	51.967 2.0459	45.025 1.7726	45.052 1.7737	0.0836	JR40x45x20.5	45
0.075 0.165	45 1.7717	44.989 1.7712	51.967 2.0459	51.986 2.0467	51.967 2.0459	45.025 1.7726	45.052 1.7737	0.0836	JR40x45x20.5	
0.097 0.214	50 1.9685	49.989 1.9681	57.967 2.2822	57.986 2.2829	57.967 2.2822	50.025 1.9695	50.052 1.9706	0.0937	JR45x50x25.5	50
0.083 0.183	50 1.9685	49.989 1.9681	57.967 2.2822	57.986 2.2829	57.967 2.2822	50.025 1.9695	50.052 1.9706	0.0937	JR45x50x25.5	





NEEDLE ROLLER BEARINGS

**FULL
COMPLEMENT
OPEN ENDS,
CLOSED ONE END
METRIC SERIES**

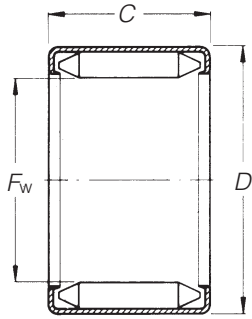

DL

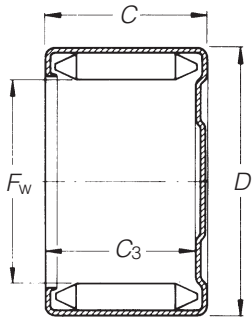

DLF

Shaft Dia.	Dimensions mm/in.				Bearing Designation	Load Ratings kN/lbf.		Limiting Speed Approx.		C ₉
	-0.3, -.012					Dynamic	Static	Grease	Oil	
mm	F _w	D	C	C _{3 min}		C	C ₀	RPM		
6	6	12	10	-	DL 6 10	2.90	3.80	33000	50000	0.0120
	0.2362	0.4724	0.394			650	850			
	6	12	10	7.7	DLF 6 10	2.90	3.80	33000	50000	0.0120
	0.2362	0.4724	0.394	0.303		650	850			
8	8	14	10	-	DL 8 10	4.50	6.50	24000	37500	0.0145
	0.3150	0.5512	0.394			1010	1460			
	8	14	10	7.7	DLF 8 10	4.50	6.50	24000	37500	0.0145
	0.3150	0.5512	0.394	0.303		1010	1460			
10	10	16	12	-	DL 10 12	7.00	10.9	20000	30000	0.0180
	0.3937	0.6299	0.472			1570	2450			
	10	16	12	9.7	DLF 10 12	7.00	10.9	20000	30000	0.0180
	0.3937	0.6299	0.472	0.382		1570	2450			
12	12	18	10	-	DL 12 10	6.00	9.7	16000	25000	0.0195
	0.4724	0.7087	0.394			1350	2180			
	12	20	12	-	DL 12 12	7.00	11.5	16000	25000	0.0206
	0.4724	0.7874	0.472			1570	2590			
	12	20	12	9.7	DLF 12 12	7.00	11.5	16000	25000	0.0206
	0.4724	0.7874	0.472	0.382		1570	2590			
13	13	19	12	-	DL 13 12	8.50	14.2	15000	23000	0.0217
	0.5118	0.7480	0.472			1910	3190			
	13	19	12	9.7	DLF 13 12	8.50	14.2	15000	23000	0.0217
	0.5118	0.7480	0.472	0.382		1910	3190			
14	14	20	12	-	DL 14 12	7.90	13.5	14000	21500	0.0229
	0.5512	0.7874	0.472			1780	3030			
	14	20	12	9.7	DLF 14 12	7.90	13.5	14000	21500	0.0229
	0.5512	0.7874	0.472	0.382		1780	3030			
15	15	21	12	-	DL 15 12	9.40	16.4	13000	20000	0.0238
	0.5906	0.8268	0.472			2110	3690			
	15	21	12	9.7	DLF 15 12	9.40	16.4	13000	20000	0.0238
	0.5906	0.8268	0.472	0.382		2110	3690			
16	16	22	12	-	DL 16 12	8.70	15.5	12000	18500	0.0251
	0.6299	0.8661	0.472			1960	3480			
	16	22	12	9.7	DLF 16 12	8.70	15.5	12000	18500	0.0251
	0.6299	0.8661	0.472	0.382		1960	3480			
17	17	23	12	-	DL 17 12	9.00	16.2	11000	17500	0.0260
	0.6693	0.9055	0.472			2020	3640			
	17	23	12	9.7	DLF 17 12	9.00	16.2	11000	17500	0.0260
	0.6693	0.9055	0.472	0.382		2020	3640			
18	18	24	12	-	DL 18 12	10.7	19.5	11000	16500	0.0272
	0.7087	0.9449	0.472			2410	4380			
	18	24	12	9.7	DLF 18 12	10.7	19.5	11000	16500	0.0272
	0.7087	0.9449	0.472	0.382		2410	4380			
	18	24	16	-	DL 18 16	16.0	29.5	11000	16500	0.0304
	0.7087	0.9449	0.630			3600	6630			
	18	24	16	13.7	DLF 18 16	16.0	29.5	11000	16500	0.0304
	0.7087	0.9449	0.630	0.539		3600	6630			
20	20	26	12	-	DL 20 12	10.2	19.5	10000	15000	0.0292
	0.7874	1.0236	0.472			2290	4380			
	20	26	12	9.7	DLF 20 12	10.2	19.5	10000	15000	0.0292
	0.7874	1.0236	0.472	0.382		2290	4380			
	20	26	16	-	DL 20 16	16.0	30.5	10000	15000	0.0327
	0.7874	1.0236	0.630			3600	6860			
	20	26	16	13.7	DLF 20 16	16.0	30.5	10000	15000	0.0327
	0.7874	1.0236	0.630	0.539		3600	6860			
22	22	28	16	-	DL 22 16	17.0	33.0	8800	13500	0.0349
	0.8661	1.1024	0.630			3820	7420			
	22	28	16	13.7	DLF 22 16	17.0	33.0	8800	13500	0.0349
	0.8661	1.1024	0.630	0.539		3820	7420			

Wt. kg/lbs.	Mounting Dimensions mm/in.					Plug Gage		Matching Inner Ring	Shaft Dia. mm
	Max.	Min.	Min.	Max.	Ring Gage	Go	No-Go		
	S		H			C _g			
0.004 0.009	6.000 0.2362	5.995 0.2360	12.000 0.4724	12.011 0.4729	12.000 0.4724	6.009 0.2366	6.036 0.2376		6
0.004 0.010	6.000 0.2362	5.995 0.2360	12.000 0.4724	12.011 0.4729	12.000 0.4724	6.009 0.2366	6.036 0.2376		
0.005 0.012	8.000 0.3150	7.994 0.3147	14.000 0.5512	14.011 0.5516	14.000 0.5512	8.009 0.3153	8.036 0.3164		8
0.005 0.012	8.000 0.3150	7.994 0.3147	14.000 0.5512	14.011 0.5516	14.000 0.5512	8.009 0.3153	8.036 0.3164		
0.008 0.018	10.000 0.3937	9.994 0.3935	16.000 0.6299	16.011 0.6304	16.000 0.6299	10.009 0.3941	10.036 0.3951		10
0.008 0.018	10.000 0.3937	9.994 0.3935	16.000 0.6299	16.011 0.6304	16.000 0.6299	10.009 0.3941	10.036 0.3951		
0.008 0.017	12.000 0.4724	11.992 0.4721	18.000 0.7087	18.011 0.7091	18.000 0.7087	12.009 0.4728	12.035 0.4738		12
0.009 0.021	12.000 0.4724	11.992 0.4721	20.000 0.7874	20.013 0.7879	20.000 0.7874	12.009 0.4728	12.035 0.4738	0.0270	IM 8 12 12.4
0.009 0.021	12.000 0.4724	11.992 0.4721	20.000 0.7874	20.013 0.7879	20.000 0.7874	12.009 0.4728	12.035 0.4738	0.0270	IM 8 12 12.4
0.010 0.022	13.000 0.5118	12.992 0.5115	19.000 0.7480	19.013 0.7485	19.000 0.7480	13.009 0.5122	13.035 0.5132	0.0285	IM 9 13 12.4
0.010 0.022	13.000 0.5118	12.992 0.5115	19.000 0.7480	19.013 0.7485	19.000 0.7480	13.009 0.5122	13.035 0.5132	0.0285	IM 9 13 12.4
0.011 0.023	14.000 0.5512	13.992 0.5509	20.000 0.7874	20.013 0.7879	20.000 0.7874	14.009 0.5515	14.035 0.5526	0.0300	IM 10 14 12.4
0.011 0.023	14.000 0.5512	13.992 0.5509	20.000 0.7874	20.013 0.7879	20.000 0.7874	14.009 0.5515	14.035 0.5526	0.0300	IM 10 14 12.4
0.011 0.024	15.000 0.5906	14.992 0.5902	21.000 0.8268	21.013 0.8273	21.000 0.8268	15.009 0.5909	15.035 0.5919	0.0312	IM 12 15 12.4
0.011 0.024	15.000 0.5906	14.992 0.5902	21.000 0.8268	21.013 0.8273	21.000 0.8268	15.009 0.5909	15.035 0.5919	0.0312	IM 12 15 12.4
0.012 0.026	16.000 0.6299	15.992 0.6296	22.000 0.8661	22.013 0.8667	22.000 0.8661	16.009 0.6303	16.035 0.6313		16
0.012 0.026	16.000 0.6299	15.992 0.6296	22.000 0.8661	22.013 0.8667	22.000 0.8661	16.009 0.6303	16.035 0.6313		
0.013 0.029	17.000 0.6693	16.992 0.6690	23.000 0.9055	23.013 0.9060	23.000 0.9055	17.009 0.6696	17.035 0.6707	0.0341	IM 13 17 12.4
0.013 0.029	17.000 0.6693	16.992 0.6690	23.000 0.9055	23.013 0.9060	23.000 0.9055	17.009 0.6696	17.035 0.6707	0.0341	IM 13 17 12.4
0.014 0.031	18.000 0.7087	17.992 0.7083	24.000 0.9449	24.013 0.9454	24.000 0.9449	18.009 0.7090	18.035 0.7100	0.0357	IM 13 18 12.4
0.014 0.031	18.000 0.7087	17.992 0.7083	24.000 0.9449	24.013 0.9454	24.000 0.9449	18.009 0.7090	18.035 0.7100	0.0357	IM 13 18 12.4
0.019 0.042	18.000 0.7087	17.992 0.7083	24.000 0.9449	24.013 0.9454	24.000 0.9449	18.009 0.7090	18.035 0.7100	0.0399	IM 13 18 16.4
0.019 0.042	18.000 0.7087	17.992 0.7083	24.000 0.9449	24.013 0.9454	24.000 0.9449	18.009 0.7090	18.035 0.7100	0.0399	IM 13 18 16.4
0.015 0.033	20.000 0.7874	19.991 0.7870	26.000 1.0236	26.013 1.0241	26.000 1.0236	20.009 0.7878	20.035 0.7888	0.0383	IM 15 20 12.4
0.015 0.033	20.000 0.7874	19.991 0.7870	26.000 1.0236	26.013 1.0241	26.000 1.0236	20.009 0.7878	20.035 0.7888	0.0383	IM 15 20 12.4
0.020 0.044	20.000 0.7874	19.991 0.7870	26.000 1.0236	26.013 1.0241	26.000 1.0236	20.009 0.7878	20.035 0.7888	0.0429	IM 15 20 16.4
0.020 0.044	20.000 0.7874	19.991 0.7870	26.000 1.0236	26.013 1.0241	26.000 1.0236	20.009 0.7878	20.035 0.7888	0.0429	IM 15 20 16.4
0.022 0.049	22.000 0.8661	21.991 0.8658	28.000 1.1024	28.013 1.1029	28.000 1.1024	20.009 0.7878	20.035 0.7888	0.0458	IM 17 22 16.4
0.022 0.049	22.000 0.8661	21.991 0.8658	28.000 1.1024	28.013 1.1029	28.000 1.1024	20.009 0.7878	20.035 0.7888	0.0458	IM 17 22 16.4

Continued on next page.



NEEDLE ROLLER BEARINGS

**FULL
COMPLEMENT
OPEN ENDS,
CLOSED ONE END
METRIC SERIES**

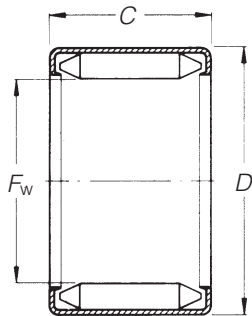

DL

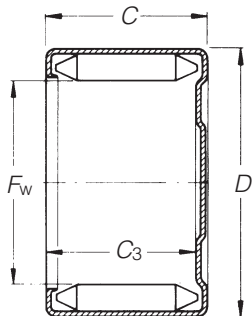

DLF

Shaft Dia.	Dimensions mm/in.				Bearing Designation	Load Ratings kN/lbf.		Limiting Speed Approx.		C _g
	F _w	D	C	C _{3 min}		Dynamic	Static	Grease	Oil	
mm						C	C ₀	RPM		
25	25	33	16	-	DL 25 16	16.0	32.5	7800	12000	0.0348
	0.9843	1.2992	0.630			3600	7310			
	25	33	16	13.7	DLF 25 16	16.0	32.5	7800	12000	0.0348
	0.9843	1.2992	0.630	0.539		3600	7310			
	25	33	20	-	DL 25 20	22.8	46.0	7800	12000	0.0379
	0.9843	1.2992	0.787			5130	10300			
	25	33	20	17.7	DLF 25 20	22.8	46.0	7800	12000	0.0379
	0.9843	1.2992	0.787	0.697		5130	10300			
28	28	36	20	-	DL 28 20	24.5	52.0	7200	11000	0.0417
	1.1024	1.4173	0.787			5510	11700			
30	30	38	16	-	DL 30 16	21.7	46.5	6500	10000	0.0403
	1.1811	1.4961	0.630			4880	10500			
	30	38	20	-	DL 30 20	26.0	56.0	6500	10000	0.0437
	1.1811	1.4961	0.787			5850	12600			
	30	38	20	17.7	DLF 30 20	26.0	56.0	6500	10000	0.0437
	1.1811	1.4961	0.787	0.697		5850	12600			
	30	38	25	-	DL 30 25	35.5	76.0	6500	10000	0.0470
	1.1811	1.4961	0.984			7980	17100			
35	35	35	16	-	DL 35 16	24.0	54.0	5500	8500	0.0437
	1.3780	0.0000	0.630			5400	12100			
	35	43	20	-	DL 35 20	29.0	65.0	5500	8500	0.0477
	1.3780	1.6929	0.787			6520	14600			
	35	43	20	17.7	DLF 35 20	29.0	65.0	5500	8500	0.0477
	1.3780	1.6929	0.787	0.697		6520	14600			
40	40	48	16	-	DL 40 16	26.5	62.0	4900	7500	0.0479
	1.5748	1.8898	0.630			5960	13900			
	40	48	20	-	DL 40 20	36.0	84.0	4900	7500	0.0523
	1.5748	1.8898	0.787			8090	18900			
	40	48	20	17.7	DLF 40 20	36.0	84.0	4900	7500	0.0523
	1.5748	1.8898	0.787	0.697		8090	18900			
44	44	52	16	-	DL 44 16	23.8	57.0	4400	6800	0.0512
	1.7323	2.0472	0.630			5350	12800			
47	47	55	16	-	DL 47 16	25.0	61.0	4200	6400	0.0536
	1.8504	2.1654	0.630			5620	13700			
50	50	58	12	-	DL 50 12	20.0	50.0	3900	6000	0.0508
	1.9685	2.2835	0.472			4500	11200			
	50	58	18	-	DL 50 18	36.5	92.0	3900	6000	0.0587
	1.9685	2.2835	0.709			8210	20700			
	50	58	20	-	DL 50 20	37.0	93.0	3900	6000	0.0611
	1.9685	2.2835	0.787			8320	20900			
	50	58	20	17.7	DLF 50 20	37.0	93.0	3900	6000	0.0611
	1.9685	2.2835	0.787	0.697		8320	20900			
55	55	63	20	-	DL 55 20	39.5	102.0	3600	5500	0.0653
	2.1654	2.4803	0.787			8880	22900			

Wt. kg/lbs.	Mounting Dimensions mm/in.								Matching Inner Ring	Shaft Dia. mm
	Max.	Min.	Min.	Max.	Ring Gage	Plug Gage		C _g		
	S		H			Go	No-Go			
0.035 0.077	25.000 0.9843	24.991 0.9839	33.000 1.2992	33.016 1.2998	33.000 1.2992	22.009 0.8665	22.035 0.8675	0.0457	IM 20 25 16.4	25
0.035 0.077	25.000 0.9843	24.991 0.9839	33.000 1.2992	33.016 1.2998	33.000 1.2992	22.009 0.8665	22.035 0.8675	0.0457	IM 20 25 16.4	
0.043 0.095	25.000 0.9843	24.991 0.9839	33.000 1.2992	33.016 1.2998	33.000 1.2992	25.015 0.9848	25.041 0.9859	0.0497	IM 20 25 20.4	
0.043 0.095	25.000 0.9843	24.991 0.9839	33.000 1.2992	33.016 1.2998	33.000 1.2992	25.015 0.9848	25.041 0.9859	0.0497	IM 20 25 20.4	
0.047 0.104	28.000 1.1024	27.991 1.1020	36.000 1.4173	36.016 1.4180	36.000 1.4173	28.015 1.1030	28.041 1.1040	0.0547	IM 23 28 20.4	28
0.040 0.088	30.000 1.1811	29.991 1.1807	38.000 1.4961	38.016 1.4967	38.000 1.4961	30.015 1.1817	30.041 1.1827	0.0529	IM 25 30 16.4	30
0.050 0.110	30.000 1.1811	29.991 1.1807	38.000 1.4961	38.016 1.4967	38.000 1.4961	30.015 1.1817	30.041 1.1827	0.0573	IM 25 30 20.4	
0.050 0.110	30.000 1.1811	29.991 1.1807	38.000 1.4961	38.016 1.4967	38.000 1.4961	30.015 1.1817	30.041 1.1827	0.0573	IM 25 30 20.4	
0.063 0.139	30.000 1.1811	29.991 1.1807	38.000 1.4961	38.016 1.4967	38.000 1.4961	30.015 1.1817	30.041 1.1827	0.0617	IM 25 30 25	
0.046 0.101	35.000 1.3780	34.989 1.3775	0.000 0.0000	#N/A #N/A	43.000 1.6929	35.015 1.3785	35.041 1.3796	0.0573	IM 30 35 16.4	35
0.057 0.126	35.000 1.3780	34.989 1.3775	43.000 1.6929	43.016 1.6935	43.000 1.6929	35.015 1.3785	35.041 1.3796	0.0626	IM 30 35 20.4	
0.057 0.126	35.000 1.3780	34.989 1.3775	43.000 1.6929	43.016 1.6935	43.000 1.6929	35.015 1.3785	35.041 1.3796	0.0626	IM 30 35 20.4	
0.051 0.112	40.000 1.5748	39.989 1.5744	48.000 1.8898	48.016 1.8904	48.000 1.8898	40.015 1.5754	40.041 1.5764	0.0628	IM 35 40 16.4	40
0.064 0.141	40.000 1.5748	39.989 1.5744	48.000 1.8898	48.016 1.8904	48.000 1.8898	40.015 1.5754	40.041 1.5764	0.0686	IM 35 40 20.4	
0.064 0.141	40.000 1.5748	39.989 1.5744	48.000 1.8898	48.016 1.8904	48.000 1.8898	40.015 1.5754	40.041 1.5764	0.0686	IM 35 40 20.4	
0.056 0.123	44.000 1.7323	43.989 1.7319	52.000 2.0472	52.019 2.0480	52.000 2.0472	44.015 1.7329	44.041 1.7339	0.0672	IM 40 44 16.4	44
0.060 0.132	47.000 1.8504	46.989 1.8500	55.000 2.1654	55.019 2.1661	55.000 2.1654	47.015 1.8510	47.041 1.8520	0.0703	IM 40 44 16.4	47
0.047 0.104	50.000 1.9685	49.989 1.9681	58.000 2.2835	58.019 2.2842	58.000 2.2835	50.015 1.9691	50.041 1.9701			50
0.071 0.157	50.000 1.9685	49.989 1.9681	58.000 2.2835	58.019 2.2842	58.000 2.2835	50.015 1.9691	50.041 1.9701			
0.077 0.170	50.000 1.9685	49.989 1.9681	58.000 2.2835	58.019 2.2842	58.000 2.2835	50.015 1.9691	50.041 1.9701	0.0802	IM 45 50 20.4	
0.077 0.170	50.000 1.9685	49.989 1.9681	58.000 2.2835	58.019 2.2842	58.000 2.2835	50.015 1.9691	50.041 1.9701	0.0802	IM 45 50 20.4	
0.086 0.190	55.000 2.1654	54.987 2.1648	63.000 2.4803	63.019 2.4811	63.000 2.4803	55.015 2.1659	55.041 2.1670	0.0857	IM 50 55 20.4	55





NEEDLE ROLLER BEARINGS

DRAWN CUP NEEDLE ROLLER BEARINGS – INCH SERIES

When a rolling bearing is needed for a compact and economical design where it is not practical to harden and grind the housing bore, or where the housing materials are of low rigidity such as cast iron, aluminum or even plastics, drawn cup needle roller bearings should be considered.

REFERENCE STANDARDS

- **ANSI/ABMA 18.2** - Needle roller bearings - Radial, inch design.

Before selecting specific inch series drawn cup needle roller bearings, the engineering section of this catalog should be reviewed.

TYPES OF INCH SERIES DRAWN CUP NEEDLE ROLLER BEARINGS



B

Full complement bearings



M



J

Caged bearings

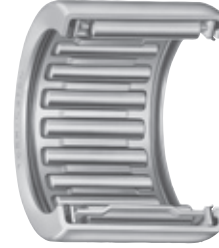

JTT

IDENTIFICATION

The prefix letter or letters in inch series drawn cup bearing designation denote whether the bearings are made with a full complement of needle rollers or caged needle rollers. The use of full complement of needle rollers is indicated by the prefix code letter B and for use of caged needle rollers by the prefix code letter J.

Inch bearings are available in either of two radial cross-sections. The larger cross-section is indicated by the prefix code letter H. Absence of the letter H indicates the smaller radial cross section.

These major features of dimension and construction are summarized in Table 1.

In addition, there can be other identifying letters which cover special modification. Please consult your Timken representative when special modifications are required.

Since the entire identification code in the bearing designation may not appear on the bearing itself, the manufacturer's parts list or another reliable source should always be consulted when ordering bearings for service or field replacement to make certain that the correct bearing with the correct lubricant is used.

TABLE 1 – IDENTIFYING LETTERS – INCH SERIES

	Prefix letters in Bearing Designation	
	Smaller Roller	Larger Roller
Full complement (mechanically retained)	B	BH
Caged	J	JH

Other prefix letters denoting major construction features are:

- M – closed end style
- P – open end (finger) cage
- T – single seal
- TT – double seal
- G – extra-precision

CONSTRUCTION

FULL COMPLEMENT BEARINGS

The original drawn cup needle roller bearing employs a full complement of needle rollers. The full complement drawn cup bearing combines maximum load carrying capability and low cost with the advantages of the drawn outer ring.

The inward turned lips of the cup are used to mechanically

retain the full complement of needle rollers, providing their positive radial retention even though it may be necessary to remove the shaft repeatedly during servicing of the mechanism employing the bearing.

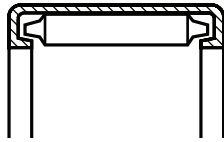

Full Complement Bearing

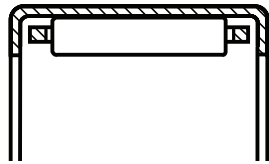

Caged Bearing

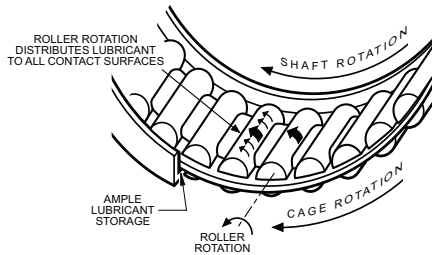

CAGED BEARINGS

The one-piece steel cage, used in most Timken® Torrington® caged drawn cup bearings, is designed to provide rigidity and minimize wear. This cage design separates the roller guiding and roller retention functions. The portions of the cage that retain the rollers cannot contact the rollers while the bearing is operating. Thus, there is no wear which might affect roller retention.

The cage contacts the rollers only near their ends at the roller pitch line, so accurate guidance is achieved with least effort. Pitch line guidance at the ends of the rollers prevents skewing and assures roller stability, with little stress on the cage itself. The design minimizes the contact area and force required for roller guidance, and thus minimizes drag between cage and rollers.

The same design feature which assures no contact between roller retention bars and rollers while the bearing is operating also provides ample clearance along the length of the roller to enhance the circulation of lubricant.

Timken also has available bearings with other cage designs. Bearings with engineered polymer cages are for use where operating conditions permit. Before applying bearings with engineered polymer cages, please consult your Timken representative.

SEALED BEARINGS

Drawn cup caged needle roller bearings are offered with integral seals. The tables of dimensions on pages C90-C91 indicate those sizes available with lip contact seals which limit the bearing operating temperature between -25° F and 225° F. The seal lip design achieves a light and constant contact with the shaft throughout the range of mounting bearing clearances thereby ensuring positive sealing and low frictional drag.

Sealed drawn cup bearings are intended to retain grease or non-pressurized oil within a bearing while also preventing contaminants from entering the raceway area.

Details of shaft design for sealed bearings are given in the engineering section.

The standard lip contact seals are compatible with common lubricating oils and petroleum based fuels, but they are adversely affected by certain fire-resistant hydraulic fluids and most common solvents.

If the operating temperature must be outside of the specified range, or if the seals are exposed to unusual fluids, please consult your Timken representative.

DIMENSIONAL ACCURACY AND MOUNTING DIMENSIONS

MANUFACTURING TOLERANCES AND RESULTING CLEARANCES

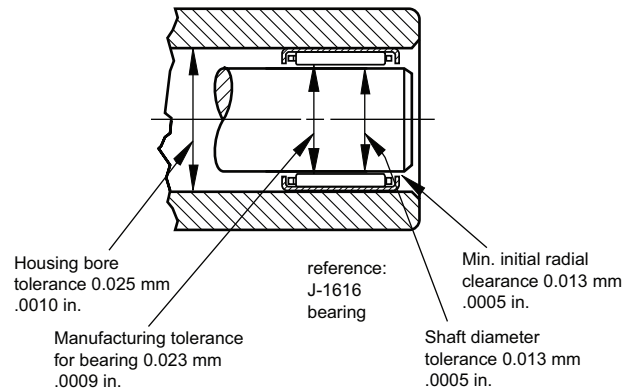

BEARING MOUNTING FITS AND RADIAL INTERNAL CLEARANCE

Drawn cup bearings are manufactured to a degree of precision that will satisfy the radial clearance requirements of most applications. The total radial clearance of an installed drawn cup bearing results from the build up of manufacturing tolerances of the housing bore, inner raceway O.D. and the bearing, as well as the minimum radial clearance required for the application.

For bearings of nominal inch dimensions, the suggested mounting dimensions will provide correct running clearance for most applications. Closer control of radial clearance would be governed by the user's capability of holding housing and shaft raceway dimensional tolerances tighter than the limits shown on the tabular pages.

The drawing illustrates the manufacturing tolerances and resulting clearances applying to medium size drawn cup bearings in rotating applications when using the suggested tabulated mounting dimensions.

Radial clearance in a mounted bearing may be more closely controlled by reducing the manufacturing tolerances of the housing bore and inner raceway diameter. Where extremely close control of radial clearance is required for bearings of nominal inch dimensions, extra-precision full complement bearings are available (see page C80).



TOLERANCES FOR HOUSING MATERIALS OF LOW RIGIDITY

For housing materials of low rigidity, or steel housings of small section, it is suggested that for initial trial the housing bore diameters given in the tabular pages be reduced by the amounts shown in Table 3. To maintain normal radial internal clearance, the inner raceway diameter tolerance given in the tabular pages should be used.

TABLE 3 – LOW RIGIDITY HOUSING BORE

Nom. Housing Bore				Subtract	
inch				inch	
mm	inch	mm	inch	mm	inch
over	incl.	over	incl.		
0	9.5	0	.38	.010	.0004
9.5	25.4	.38	1.00	.015	.0006
25.4	50.8	1.00	2.00	.025	.0010
50.8	76.2	2.00	3.00	.030	.0012
76.2	152.4	3.00	6.00	.036	.0014

OUTER RING ROTATION

For applications where the outer ring rotates with respect to the load, it is suggested that both the housing bore and inner raceway diameter be reduced. Bearings of nominal inch dimensions should have the housing bore and inner raceway diameters reduced by .0005 in.

OSCILLATING MOTION

Applications involving oscillating motion often require reduced radial clearances. This reduction is accomplished by increasing the shaft raceway diameters as shown in Table 4.

TABLE 4 – NOMINAL INCH BEARING OSCILLATING SHAFT SIZE

Shaft Size		Add	
mm	inch	mm	inch
2.38 to 4.76	.094 to .188	.008	.0003
6.35 to 47.62	.25 to 1.875	.013	.0005
50.8 to 139.7	2 to 5.5	.015	.0006

INNER RINGS

Where it becomes impractical to meet the shaft raceway design requirements (hardness, case depth, surface finish, etc.) outlined in the general engineering section, standard inner rings for drawn cup bearings are available. These are tabulated on pages C92 of the drawn cup section.

Inner rings for drawn cup bearings are designed to be a loose transition fit on the shaft and should be clamped against a shoulder. If a tight transition fit must be used to keep the inner ring from rotating relative to the shaft, the inner ring O.D., as mounted, must not exceed the raceway diameters required by the drawn cup bearing for the particular application. See the previous discussion on internal clearances and fits for further details on inner raceway diameter choice.

LUBRICATION

Inch series drawn cup bearings can be furnished with an oil hole (centered in the drawn cup) to facilitate relubrication. If desired, specify on order by adding an -OH suffix to the bearing designation.

LOAD RATING FACTORS DYNAMIC LOADS

Drawn cup needle roller bearings can accommodate only radial loads.

$$P = F_r$$

P = The maximum dynamic radial load that may be applied to a drawn cup bearing based on the dynamic load rating, C given in the tabular pages. This load should be $\leq C/3$.

STATIC LOADS

$$f_0 = \frac{C_0}{P_0}$$

f_0 – static load safety factor

C_0 – basic static load rating

P_0 – maximum applied static load

To ensure satisfactory operation of drawn cup needle roller bearings under all types of conditions the static load safety factor f_0 should be ≥ 3 .

ADJUSTED RATING LIFE

When application data includes details of operating temperature, oil viscosity, operating speed and the applied load meets the $\leq C/3$ condition adjusted rating life may be evaluated using the information given in the engineering section.

C

INSPECTION PROCEDURES

Although the bearing cup (outer ring) is accurately drawn from strip steel it may go out of round during heat treatment. When the bearing is pressed into a true, round housing or ring gage of correct size and wall thickness, it becomes round and is sized properly. For this reason, it is incorrect to inspect an unmounted drawn cup bearing by measuring the O.D. The correct method for inspecting the bearing size is to:

1. press the bearing into a ring gage of proper size.
2. plug the bearing bore with the appropriate "go" and "no go" gages.

Table 2 provides the correct ring and plug gage diameters for inspecting Torrington drawn cup needle roller bearings. When the letter H appears in the columns headed "Bearing Bore Designation" and "Nominal Shaft Diameter", the gage sizes listed are for the larger cross section bearings which include H in their bearing designation prefix.

EXAMPLE

Find the ring gage and plug gage dimensions for a BH-68 bearing.

The nominal bore diameter (F_w) for this bearing, as shown in the table of dimensions on this page, is .3750". Since the letter H appears in the bearing designation, the following information will be found opposite H6 .3750" in Table 2.

	inch
ring gage	.6255
diameter under needle rollers, min.	.3765
diameter under needle rollers, max.	.3774

The "go" plug gage is the same size as the minimum needle roller complement bore diameter and the "no go" plug gage size is .0001" larger than the maximum bore diameter. Therefore the correct ring and plug gage dimensions are:

	inch
ring gage	.6255
plug gage, "go"	.3765
plug gage, "no go"	.3775

These same gage dimensions also apply to JH-68.

TABLE 2 –
INCH SERIES BEARINGS

Bearing Bore Designation	Nominal Shaft Diameter	Nominal Bore Diameter	Ring Gage	Dimensions - inch	
				Needle Roller Complement Bore Diameter	
inch				min.	max.
2	1/8	.1250	.2505	.1258	.1267
2 1/2	5/32	.1562	.2817	.1571	.1580
3	3/16	.1875	.3437	.1883	.1892
4	1/4	.2500	.4380	.2515	.2524
5	5/16	.3125	.5005	.3140	.3149
H 5	H 5/16	.3125	.5630	.3140	.3149
6	3/8	.3750	.5630	.3765	.3774
H 6	H 3/8	.3750	.6255	.3765	.3774
7	7/16	.4375	.6255	.4390	.4399
H 7	H 7/16	.4375	.6880	.4390	.4399
8	1/2	.5000	.6880	.5015	.5024
H 8	H 1/2	.5000	.7505	.5015	.5024
9	9/16	.5625	.7505	.5640	.5649
H 9	H 9/16	.5625	.8130	.5640	.5649
10	5/8	.6250	.8130	.6265	.6274
H 10	H 5/8	.6250	.8755	.6265	.6274
11	11/16	.6875	.8755	.6890	.6899
H 11	H 11/16	.6875	.9380	.6890	.6899
12	3/4	.7500	.9995	.7505	.7514
H 12	H 3/4	.7500	1.0620	.7505	.7514
13	13/16	.8125	1.0620	.8130	.8139
H 13	H 13/16	.8125	1.1245	.8130	.8139
14	7/8	.8750	1.1245	.8755	.8764
H 14	H 7/8	.8750	1.1870	.8755	.8764
15	15/16	.9375	1.1870	.9380	.9389
16	1	1.0000	1.2495	1.0005	1.0014
H 16	H 1	1.0000	1.3120	1.0005	1.0014
17	1 1/16	1.0625	1.3120	1.0630	1.0639
18	1 1/8	1.1250	1.3745	1.1255	1.1264
H 18	H 1 1/8	1.1250	1.4995	1.1255	1.1264
19	1 3/16	1.1875	1.4995	1.1880	1.1889
20	1 1/4	1.2500	1.4995	1.2505	1.2514
H 20	H 1 1/4	1.2500	1.6245	1.2505	1.2514
21	1 5/16	1.3125	1.6245	1.3130	1.3140
22	1 3/8	1.3750	1.6245	1.3755	1.3765
H 22	H 1 3/8	1.3750	1.7495	1.3755	1.3765
24	1 1/2	1.5000	1.8745	1.5005	1.5016
26	1 5/8	1.6250	1.9995	1.6255	1.6266
28	1 3/4	1.7500	2.1245	1.7505	1.7517
30	1 7/8	1.8750	2.2495	1.8755	1.8767
32	2	2.0000	2.3745	2.0006	2.0018
H 32	H 2 1/16	2.0625	2.5307	2.0630	2.0644
34	2 1/8	2.1250	2.4995	2.1256	2.1270
36	2 1/4	2.2500	2.6245	2.2506	2.2520
42	2 5/8	2.6250	2.9995	2.6260	2.6274
44	2 3/4	2.7500	3.1245	2.7510	2.7524
56	3 1/2	3.5000	3.9995	3.5010	3.5024
88	5 1/2	5.5000	5.9990	5.5010	5.5029

Bearing bore should be checked with "go" and "no go" plug gages. The "go" gage size is the minimum needle roller complement bore diameter. The "no go" gage size is larger than the maximum needle roller complement bore diameter by 0.0001".



INSTALLATION OF DRAWN CUP BEARINGS

GENERAL INSTALLATION REQUIREMENTS

- A drawn cup bearing must be pressed into its housing.
- An installation tool, similar to the ones shown, must be used in conjunction with a standard press.
- The bearing must not be hammered into its housing, even in conjunction with the proper assembly mandrel.
- The bearing must not be pressed tightly against a shoulder in the housing.
- If it is necessary to use a shouldered housing, the depth of the housing bore must be sufficient to ensure the housing shoulder fillet, as well as the shoulder face, clears the bearing.
- The installation tool must be coaxial with the housing bore.

C

INSTALLATION OF OPEN END BEARINGS

It is advisable to utilize a positive stop on the press tool to locate the bearing properly in the housing. The assembly tool should have a leader or a pilot, as shown, to aid in starting the bearing true in the housing. The ball detent shown on the drawing is used to assist in aligning the rollers of a full complement bearing during installation and to hold the bearing on the installation tool. A caged type drawn cup bearing does not require a ball detent to align its rollers. The

ball detent may still be used to hold the bearing on the installation tool or an "O" ring may be used as shown in the drawing on page C41. The bearing should be installed with the marked end (the end with identification markings) against the angled shoulder of the pressing tool.

- A – $\frac{1}{64}$ " less than housing bore
- B – .003" less than shaft diameter
- C – distance bearing will be inset into housing, minimum of .008"
- D – pilot length should be length of bearing less $\frac{1}{32}$ "
- E – approximately $\frac{1}{2}$ D

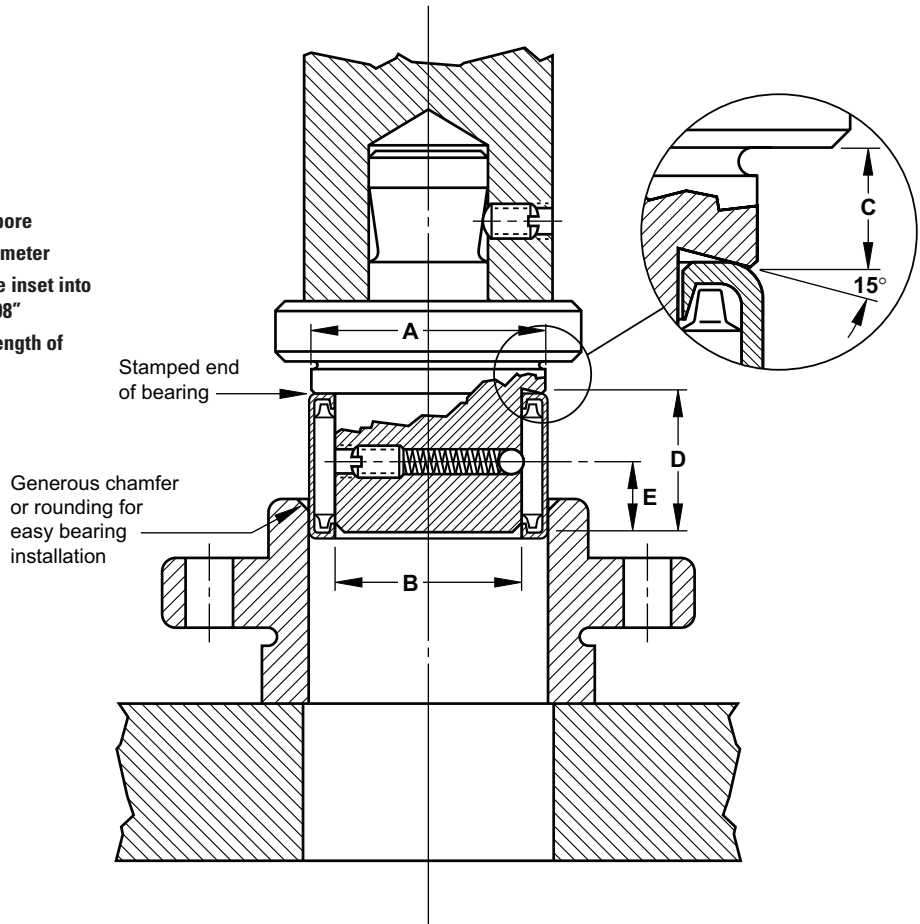

INSTALLATION OF CLOSED END BEARINGS

The installation tool combines all the features of the tool used to install open end bearings, but the pilot is spring loaded and is part of the press bed.

The angled shoulder of the pressing tool should bear against the closed end with the bearing held on the pilot to aid in starting the bearing true in the housing.

- A** – $\frac{1}{64}$ " less than housing bore
- B** – .003" less than shaft diameter
- C** – distance bearing will be inset into housing, minimum of .008"

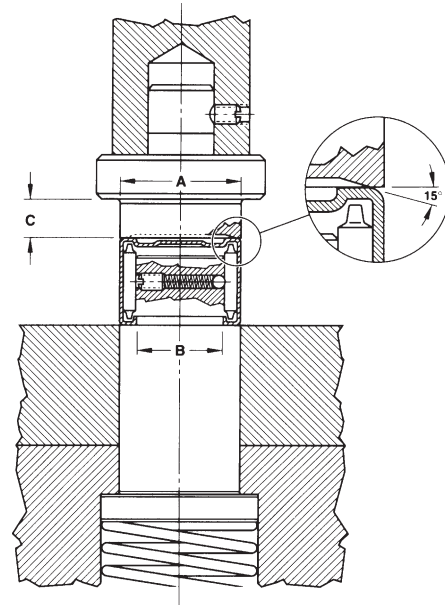

EXTRACTION OF DRAWN CUP BEARINGS

The need to extract a drawn cup bearing does not arise often. Standard extractor tools may be purchased from a reputable manufacturer. Customers may produce the special extraction tools at their own facilities. In certain cases, The Timken Company may assist, particularly when a drawn cup bearing appears to be damaged and a full analysis is required. After extraction, the drawn cup bearing should not be reused.

EXTRACTION FROM A STRAIGHT HOUSING

When it is necessary to extract a drawn cup bearing from a straight housing, a similar tool to the installation tool, but without the stop, may be used. To avoid damage to the bearing, pressure should be applied against the marked end of the bearing, just as it is done at installation.

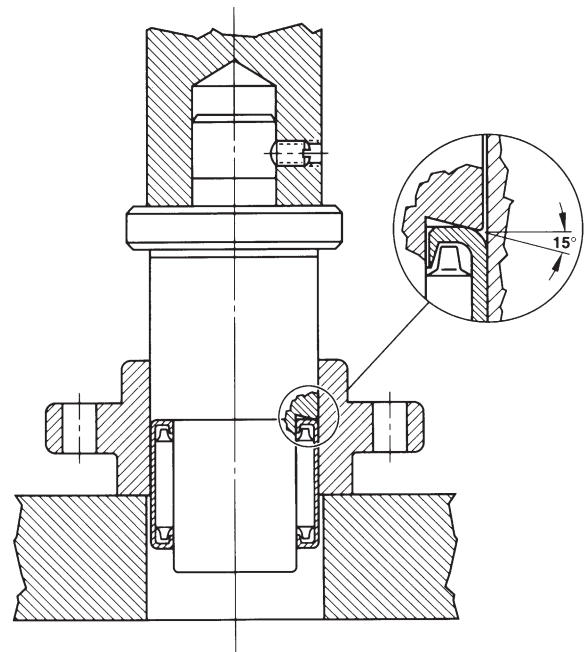



EXTRACTION FROM A SHOULDERED OR DEAD END HOUSING (with space between the bearing and the housing shoulder)

Bearings may be extracted from shouldered or dead end housings with a common bearing puller tool as shown. This type of tool is slotted in two places at right angles to form four prongs. The four puller prongs are pressed together and inserted into the space between the end of the bearing and the shoulder. The prongs are forced outward by inserting the expansion rod, and then the bearing is extracted. Do not reuse the bearing after extraction.

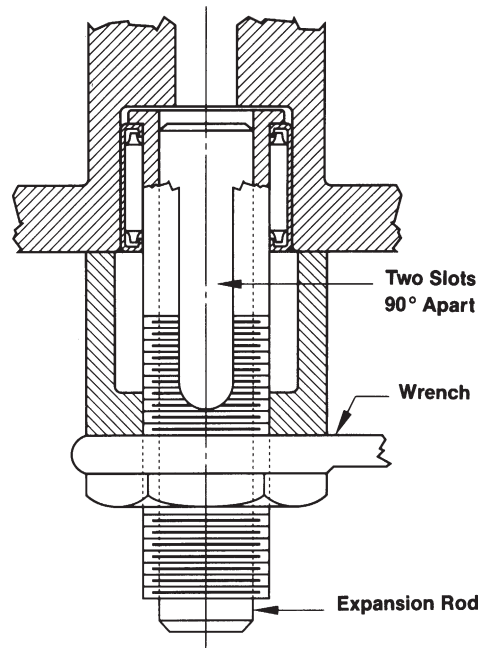

C



EXTRACTION FROM A SHOULDERED HOUSING (with bearing pressed up close to the shoulder)

The tool to be used, as shown, is of a similar type described for a shouldered or dead end housing, but the rollers must first be removed from the bearing.

The four segment puller jaws are collapsed and slipped into the empty cup. The jaws are then forced outward into the cup bore by means of the tapered expansion rod. The jaws should bear on the lip as near as possible to the cup bore. The cup is then pressed out from the top.

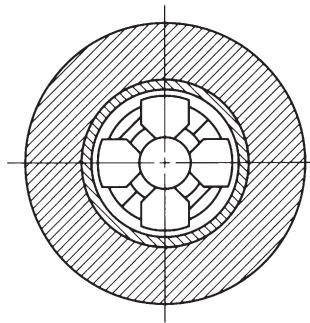

Section A-A of Four Jaws

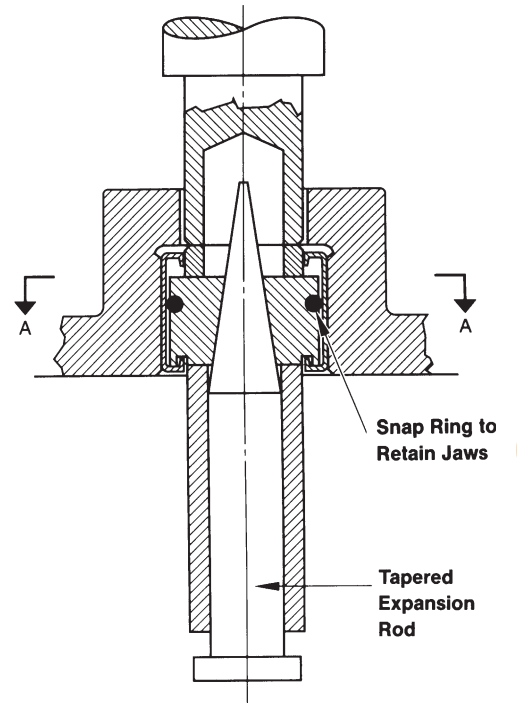

Snap Ring to Retain Jaws

Tapered Expansion Rod





**FULL COMPLEMENT BEARINGS,
OPEN ENDS, CLOSED ONE END**

INCH SERIES

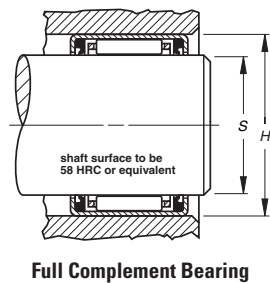
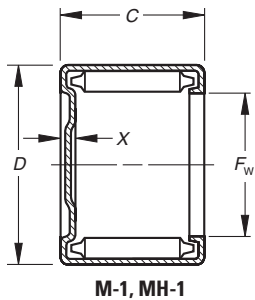
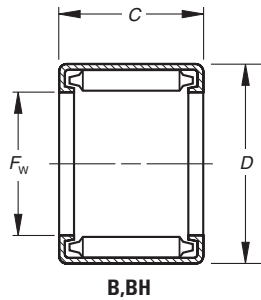

Drawn cup bearings of nominal inch dimensions, with one closed end, that are not tabulated, may be made available upon request.

Mounting dimensions are based on the inner ring rotating and the outer ring being stationary relative to the load. The housing should be of high strength material. See engineering section for discussion of shaft and housing design.

Shaft Dia.	Dimensions mm/in.				Bearing Designation		Load Ratings		Limiting Speed		C _g
	+0 +0.000 -0.3 -0.100						Dynamic	Static	Grease	Oil	
in.	F _w	D	C	Y			C	C ₀	RPM		
1/8	3.175	6.350	6.35	—	B-24	—	1.73	1.65	8100	13000	0.0081
	0.1250	0.2500	0.250				390	370			
5/32	3.970	7.142	6.35	—	B-2-1/2-4	—	2.00	2.00	7000	11000	0.0093
	0.1563	0.2812	0.250				450	450			
	3.970	7.142	7.92	—	B-2-1/2-5	—	2.58	2.80	7000	11000	0.0101
	0.1563	0.2812	0.312				580	630			
3/16	4.763	8.733	6.35	1.78	B-34	M-341	2.22	2.14	7000	11000	0.0099
	0.1875	0.3438	0.250	0.07			500	480			
	4.763	8.733	9.53	1.78	B-36	M-361	3.78	4.23	7000	11000	0.0118
	0.1875	0.3438	0.375	0.07			850	950			
1/4	6.350	11.113	6.35	2.03	B-44	M-441	2.76	2.62	6500	10000	0.0115
	0.2500	0.4375	0.250	0.08			620	590			
	6.350	11.113	7.92	2.03	B-45	M-451	3.56	3.69	6500	10000	0.0125
	0.2500	0.4375	0.312	0.08			800	830			
	6.350	11.113	9.53	—	B-46	—	4.54	5.03	6500	10000	N/A
	0.2500	0.4375	0.375				1020	1130			
5/16	6.350	11.113	11.13	2.03	B-47	M-471	5.52	6.45	6500	10000	0.0143
	0.2500	0.4375	0.438	0.08			1240	1450			
	7.938	12.700	7.92	2.03	B-55	M-551	4.09	4.58	5400	8300	0.0144
	0.3125	0.5000	0.312	0.08			920	1030			
	7.938	12.700	9.53	—	B-56	—	5.25	6.32	5400	8300	0.0156
	0.3125	0.5000	0.375				1180	1420			
	7.938	12.700	11.13	2.03	B-57	M-571	6.32	8.1	5400	8300	0.0165
	0.3125	0.5000	0.438	0.08			1420	1820			
	7.938	12.700	14.27	—	B-59	—	8.36	11.60	5400	8300	0.0181
	0.3125	0.5000	0.562				1880	2600			
	7.938	14.288	11.13	2.29	BH-57	MH-571	7.03	7.34	7500	12000	0.0156
	0.3125	0.5625	0.438	0.09			1580	1650			
	7.938	14.288	14.27	—	BH-59	—	9.47	10.80	7500	12000	0.0171
	0.3125	0.5625	0.562				2130	2420			
3/8	9.525	14.288	7.92	2.03	B-65	M-651	4.54	5.52	4600	7100	0.0162
	0.3750	0.5625	0.312	0.08			1020	1240			
	9.525	14.288	9.53	2.03	B-66	M-661	5.83	7.61	4600	7100	0.0175
	0.3750	0.5625	0.375	0.08			1310	1710			
	9.525	14.288	11.13	—	B-67	—	7.07	9.7	4600	7100	0.0186
	0.3750	0.5625	0.438				1590	2180			
	9.525	14.288	12.70	2.03	B-68	M-681	8.18	11.80	4600	7100	0.0195
	0.3750	0.5625	0.500	0.08			1840	2650			
	9.525	14.288	14.27	—	B-69	—	9.34	13.92	4600	7100	0.0203
	0.3750	0.5625	0.562				2100	3130			
	9.525	14.288	15.88	2.03	B-610	M-6101	10.4	16.00	4600	7100	0.0211
	0.3750	0.5625	0.625	0.08			2340	3590			
	9.525	15.875	12.70	—	BH-68	—	9.34	10.90	6500	10000	0.0184
	0.3750	0.6250	0.500				2100	2460			
7/16	11.113	15.875	9.53	—	B-76	—	6.36	8.90	4100	6300	0.0194
	0.4375	0.6250	0.375				1430	2000			
	11.113	15.875	11.13	—	B-77	—	7.70	11.3	4100	6300	0.0206
	0.4375	0.6250	0.438				1730	2550			
	11.113	15.875	12.70	2.03	B-78	M-781	8.99	13.80	4100	6300	0.0216
	0.4375	0.6250	0.500	0.08			2020	3100			
	11.113	15.875	15.88	—	B-710	—	11.3	18.7	4100	6300	0.0233
	0.4375	0.6250	0.625				2550	4200			

Wt. kg/lbs. Approx.		Bearing Mounting mm/in.				Inspection mm/in.			Matching Inner Ring*	Shaft Dia. in.
Open Ends	Closed Ends	Max.	Min.	Min.	Max.	Ring Gage	Plug-GO	Plug-NO-Go		
		S		H						
0.001 0.002	—	3.175 0.1250	3.167 0.1247	6.350 0.2500	6.363 0.2505	6.363 0.2505	3.195 0.1258	3.221 0.1268		1/8
0.001 0.002	—	3.970 0.1563	3.962 0.1560	7.142 0.2812	7.155 0.2817	7.155 0.2817	3.990 0.1571	4.016 0.1581		5/32
0.001 0.003	—	3.970 0.1563	3.962 0.1560	7.142 0.2812	7.155 0.2817	7.155 0.2817	3.990 0.1571	4.016 0.1581		
0.001 0.003	0.002 0.004	4.763 0.1875	4.755 0.1872	8.717 0.3432	8.730 0.3437	8.730 0.3437	4.783 0.1883	4.808 0.1893		3/16
0.002 0.005	0.003 0.006	4.763 0.1875	4.755 0.1872	8.717 0.3432	8.730 0.3437	8.730 0.3437	4.783 0.1883	4.808 0.1893		
0.002 0.005	0.003 0.006	6.350 0.2500	6.337 0.2495	11.100 0.4370	11.125 0.4380	11.125 0.4380	6.388 0.2515	6.414 0.2525		1/4
0.003 0.007	0.004 0.008	6.350 0.2500	6.337 0.2495	11.100 0.4370	11.125 0.4380	11.125 0.4380	6.388 0.2515	6.414 0.2525		
0.004 0.008	—	6.350 0.2500	6.337 0.2495	11.100 0.4370	11.125 0.4380	11.125 0.4380	6.388 0.2515	6.414 0.2525		
0.004 0.009	0.005 0.011	6.350 0.2500	6.337 0.2495	11.100 0.4370	11.125 0.4380	11.125 0.4380	6.388 0.2515	6.414 0.2525		
0.004 0.008	0.004 0.009	7.938 0.3125	7.925 0.3120	12.687 0.4995	12.713 0.5005	12.713 0.5005	7.976 0.3140	8.001 0.3150		5/16
0.005 0.010	—	7.938 0.3125	7.925 0.3120	12.687 0.4995	12.713 0.5005	12.713 0.5005	7.976 0.3140	8.001 0.3150		
0.005 0.011	0.006 0.013	7.938 0.3125	7.925 0.3120	12.687 0.4995	12.713 0.5005	12.713 0.5005	7.976 0.3140	8.001 0.3150		
0.006 0.014	—	7.938 0.3125	7.925 0.3120	12.687 0.4995	12.713 0.5005	12.713 0.5005	7.976 0.3140	8.001 0.3150		
0.007 0.016	0.008 0.018	7.938 0.3125	7.925 0.3120	14.275 0.5620	14.300 0.5630	14.300 0.5630	7.976 0.3140	8.001 0.3150		
0.009 0.020	—	7.938 0.3125	7.925 0.3120	14.275 0.5620	14.300 0.5630	14.300 0.5630	7.976 0.3140	8.001 0.3150		
0.004 0.009	0.005 0.010	9.525 0.3750	9.512 0.3745	14.275 0.5620	14.300 0.5630	14.300 0.5630	9.563 0.3765	9.589 0.3775		3/8
0.005 0.011	0.005 0.012	9.525 0.3750	9.512 0.3745	14.275 0.5620	14.300 0.5630	14.300 0.5630	9.563 0.3765	9.589 0.3775		
0.006 0.013	—	9.525 0.3750	9.512 0.3745	14.275 0.5620	14.300 0.5630	14.300 0.5630	9.563 0.3765	9.589 0.3775		
0.007 0.015	0.008 0.017	9.525 0.3750	9.512 0.3745	14.275 0.5620	14.300 0.5630	14.300 0.5630	9.563 0.3765	9.589 0.3775	IRA-3	
0.007 0.016	—	9.525 0.3750	9.512 0.3745	14.275 0.5620	14.300 0.5630	14.300 0.5630	9.563 0.3765	9.589 0.3775		
0.008 0.018	0.01 0.021	9.525 0.3750	9.512 0.3745	14.275 0.5620	14.300 0.5630	14.300 0.5630	9.563 0.3765	9.589 0.3775		
0.010 0.021	0.000	9.525 0.3750	9.512 0.3745	15.862 0.6245	15.888 0.6255	15.888 0.6255	9.563 0.3765	9.589 0.3775	IRA-3	
0.005 0.012	—	11.113 0.4375	11.100 0.4370	15.862 0.6245	15.888 0.6255	15.888 0.6255	11.151 0.4390	11.176 0.4400	IRA-4	7/16
0.007 0.015	—	11.113 0.4375	11.100 0.4370	15.862 0.6245	15.888 0.6255	15.888 0.6255	11.151 0.4390	11.176 0.4400	IRA-4	
0.008 0.017	0.009 0.019	11.113 0.4375	11.100 0.4370	15.862 0.6245	15.888 0.6255	15.888 0.6255	11.151 0.4390	11.176 0.4400	IRA-4	
0.010 0.021	—	11.113 0.4375	11.100 0.4370	15.862 0.6245	15.888 0.6255	15.888 0.6255	11.151 0.4390	11.176 0.4400		

* Further reduces shaft diameter.

Continued on next page.



FULL COMPLEMENT BEARINGS,
OPEN ENDS, CLOSED ONE END – *continued*

INCH SERIES

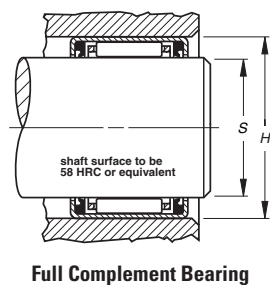
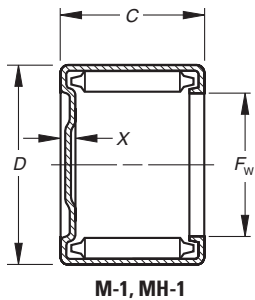
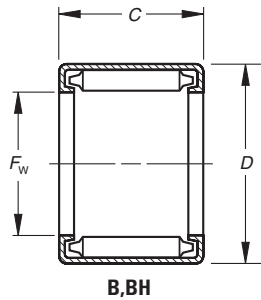

Drawn cup bearings of nominal inch dimensions, with one closed end, that are not tabulated, may be made available upon request.

Mounting dimensions are based on the inner ring rotating and the outer ring being stationary relative to the load. The housing should be of high strength material. See engineering section for discussion of shaft and housing design.

Shaft Dia.	Dimensions mm/in.				Bearing Designation		Load Ratings		Limiting Speed		C _g
	+0 +0.000 -0.3 -0.100						Dynamic	Static	Grease	Oil	
in.	F _w	D	C	Y			C	C ₀	RPM		
	11.113	17.463	12.70	—	BH-78	—	10.3	12.8	5700	8800	0.0203
	0.4375	0.6875	0.500	—			2320	2870			
1/2	12.700	17.463	7.92	2.03	B-85	M-851	5.34	7.38	3600	5600	0.0196
	0.5000	0.6875	0.312	0.08			1200	1660			
	12.700	17.463	9.53	2.03	B-86	M-861	6.85	10.1	3600	5600	0.0212
	0.5000	0.6875	0.375	0.08			1540	2280			
	12.700	17.463	11.13	2.03	B-87	M-871	8.32	13.0	3600	5600	0.0225
	0.5000	0.6875	0.438	0.08			1870	2920			
	12.700	17.463	12.70	2.03	B-88	M-881	9.61	15.7	3600	5600	0.0236
	0.5000	0.6875	0.500	0.08			2160	3530			
	12.700	17.463	15.88	2.03	B-810	M-8101	12.2	21.34	3600	5600	0.0255
	0.5000	0.6875	0.625	0.08			2750	4800			
	12.700	17.463	19.05	2.03	B-812	M-8121	14.7	27.0	3600	5600	0.0270
	0.5000	0.6875	0.750	0.08			3300	6060			
	12.700	19.050	11.13	—	BH-87	—	9.47	11.8	5100	7900	0.0210
	0.5000	0.7500	0.438	—			2130	2650			
	12.700	19.050	12.70	—	BH-88	—	11.2	14.6	5100	7900	0.0221
	0.5000	0.7500	0.500	—			2510	3280			
	12.700	19.050	15.88	—	BH-810	—	14.4	20.2	5100	7900	0.0240
	0.5000	0.7500	0.625	—			3230	4540			
	12.700	19.050	19.05	2.29	BH-812	MH-8121	17.4	25.8	5100	7900	0.0255
	0.5000	0.7500	0.750	0.09			3910	5790			
9/16	14.288	19.050	7.92	2.03	B-95	M-951	5.74	8.32	3300	5000	0.0212
	0.5625	0.7500	0.312	0.08			1290	1870			
	14.288	19.050	9.53	2.03	B-96	M-961	7.34	11.4	3300	5000	0.0229
	0.5625	0.7500	0.375	0.08			1650	2570			
	14.288	19.050	11.13	2.03	B-97	M-971	8.85	14.6	3300	5000	0.0244
	0.5625	0.7500	0.438	0.08			1990	3280			
	14.288	19.050	12.70	2.03	B-98	M-981	10.3	17.7	3300	5000	0.0256
	0.5625	0.7500	0.500	0.08			2320	3990			
	14.288	19.050	15.88	2.03	B-910	M-9101	13.1	24.0	3300	5000	0.0276
	0.5625	0.7500	0.625	0.08			2940	5400			
	14.288	19.050	19.05	2.03	B-912	M-9121	15.7	30.3	3300	5000	0.0292
	0.5625	0.7500	0.750	0.08			3520	6820			
	14.288	20.638	12.70	—	BH-98	—	12.0	16.5	4600	7100	0.0239
	0.5625	0.8125	0.500	—			2690	3700			
	14.288	20.638	15.88	—	BH-910	—	15.4	22.7	4600	7100	0.0259
	0.5625	0.8125	0.625	—			3460	5110			
	14.288	20.638	19.05	—	BH-912	—	18.6	29.0	4600	7100	0.0275
	0.5625	0.8125	0.750	—			4190	6520			
5/8	15.875	20.638	7.92	2.03	B-105	M-1051	6.1	9.25	3000	4500	0.0227
	0.6250	0.8125	0.312	0.08			1360	2080			
	15.875	20.638	11.13	2.03	B-107	M-1071	9.39	16.2	3000	4500	0.0262
	0.6250	0.8125	0.438	0.08			2110	3650			
	15.875	20.638	12.70	2.03	B-108	M-1081	10.9	19.7	3000	4500	0.0275
	0.6250	0.8125	0.500	0.08			2450	4430			
	15.875	20.638	15.88	2.03	B-1010	M-10101	13.80	26.7	3000	4500	0.0296
	0.6250	0.8125	0.625	0.08			3110	6000			
	15.875	20.638	19.05	2.03	B-1012	M-10121	16.6	33.7	3000	4500	0.0314
	0.6250	0.8125	0.750	0.08			3720	7580			
5/8	15.875	22.212	12.70	2.29	BH-108	MH-1081	12.7	18.3	4200	6500	0.0256
	0.6250	0.8745	0.500	0.09			2860	4110			

Wt. kg/lbs. Approx.		Bearing Mounting mm/in.				Inspection mm/in.			Matching Inner Ring*	Shaft Dia.
Open Ends	Closed Ends	Max.	Min.	Min.	Max.	Ring Gage	Plug-GO	Plug-NO-Go		in.
		S		H						
0.010 0.023	—	11.113 0.4375	11.100 0.4370	17.450 0.6870	17.475 0.6880	17.475 0.6880	11.151 0.4390	11.176 0.4400	IRA-4	
0.005 0.012	0.006 0.014	12.700 0.5000	12.687 0.4995	17.450 0.6870	17.475 0.6880	17.475 0.6880	12.738 0.5015	12.764 0.5025	IRA-5	1/2
0.006 0.014	0.007 0.016	12.700 0.5000	12.687 0.4995	17.450 0.6870	17.475 0.6880	17.475 0.6880	12.738 0.5015	12.764 0.5025	IRA-5	
0.007 0.016	0.008 0.018	12.700 0.5000	12.687 0.4995	17.450 0.6870	17.475 0.6880	17.475 0.6880	12.738 0.5015	12.764 0.5025	IRA-5	
0.009 0.019	0.010 0.021	12.700 0.5000	12.687 0.4995	17.450 0.6870	17.475 0.6880	17.475 0.6880	12.738 0.5015	12.764 0.5025		
0.010 0.023	0.012 0.026	12.700 0.5000	12.687 0.4995	17.450 0.6870	17.475 0.6880	17.475 0.6880	12.738 0.5015	12.764 0.5025		
0.013 0.028	0.014 0.031	12.700 0.5000	12.687 0.4995	17.450 0.6870	17.475 0.6880	17.475 0.6880	12.738 0.5015	12.764 0.5025		
0.010 0.023	—	12.700 0.5000	12.687 0.4995	19.037 0.7495	19.063 0.7505	19.063 0.7505	12.738 0.5015	12.764 0.5025	IRA-5	
0.012 0.026	—	12.700 0.5000	12.687 0.4995	19.037 0.7495	19.063 0.7505	19.063 0.7505	12.738 0.5015	12.764 0.5025	IRA-5	
0.015 0.033	—	12.700 0.5000	12.687 0.4995	19.037 0.7495	19.063 0.7505	19.063 0.7505	12.738 0.5015	12.764 0.5025		
0.018 0.039	0.020 0.044	12.700 0.5000	12.687 0.4995	19.037 0.7495	19.063 0.7505	19.063 0.7505	12.738 0.5015	12.764 0.5025		
0.006 0.013	0.006 0.014	14.288 0.5625	14.275 0.5620	19.037 0.7495	19.063 0.7505	19.063 0.7505	14.326 0.5640	14.351 0.5650	IR-68	9/16
0.007 0.015	0.008 0.018	14.288 0.5625	14.275 0.5620	19.037 0.7495	19.063 0.7505	19.063 0.7505	14.326 0.5640	14.351 0.5650	IR-68	
0.008 0.018	0.010 0.021	14.288 0.5625	14.275 0.5620	19.037 0.7495	19.063 0.7505	19.063 0.7505	14.326 0.5640	14.351 0.5650	IR-68	
0.009 0.020	0.010 0.023	14.288 0.5625	14.275 0.5620	19.037 0.7495	19.063 0.7505	19.063 0.7505	14.326 0.5640	14.351 0.5650	IR-68	
0.012 0.026	0.013 0.029	14.288 0.5625	14.275 0.5620	19.037 0.7495	19.063 0.7505	19.063 0.7505	14.326 0.5640	14.351 0.5650	IR-612	
0.014 0.031	0.015 0.034	14.288 0.5625	14.275 0.5620	19.037 0.7495	19.063 0.7505	19.063 0.7505	14.326 0.5640	14.351 0.5650	IR-612	
0.013 0.029	—	14.288 0.5625	14.275 0.5620	20.625 0.8120	20.650 0.8130	20.650 0.8130	14.326 0.5640	14.351 0.5650	IR-68	
0.016 0.036	—	14.288 0.5625	14.275 0.5620	20.625 0.8120	20.650 0.8130	20.650 0.8130	14.326 0.5640	14.351 0.5650	IR-612	
0.020 0.043	—	14.288 0.5625	14.275 0.5620	20.625 0.8120	20.650 0.8130	20.650 0.8130	14.326 0.5640	14.351 0.5650	IRA-6	
0.006 0.014	0.007 0.016	15.875 0.6250	15.862 0.6245	20.625 0.8120	20.650 0.8130	20.650 0.8130	15.913 0.6265	15.939 0.6275	IR-68-1	5/8
0.009 0.020	0.010 0.022	15.875 0.6250	15.862 0.6245	20.625 0.8120	20.650 0.8130	20.650 0.8130	15.913 0.6265	15.939 0.6275	IR-68-1	
0.010 0.022	0.012 0.026	15.875 0.6250	15.862 0.6245	20.625 0.8120	20.650 0.8130	20.650 0.8130	15.913 0.6265	15.939 0.6275	IR-68-1	
0.013 0.028	0.015 0.032	15.875 0.6250	15.862 0.6245	20.625 0.8120	20.650 0.8130	20.650 0.8130	15.913 0.6265	15.939 0.6275	IR-612-1	
0.015 0.034	0.017 0.038	15.875 0.6250	15.862 0.6245	20.625 0.8120	20.650 0.8130	20.650 0.8130	15.913 0.6265	15.939 0.6275	IR-612-1	
0.014 0.031	0.016 0.035	15.875 0.6250	15.862 0.6245	22.212 0.8745	22.238 0.8755	22.238 0.8755	15.913 0.6265	15.939 0.6275	IR-68-1	5/8

* Further reduces shaft diameter.

Continued on next page.



**FULL COMPLEMENT BEARINGS,
OPEN ENDS, CLOSED ONE END** – *continued*

INCH SERIES

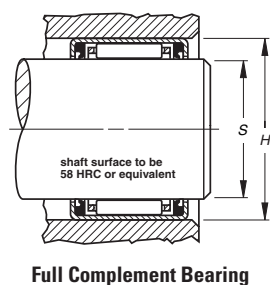
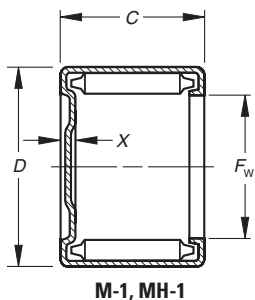
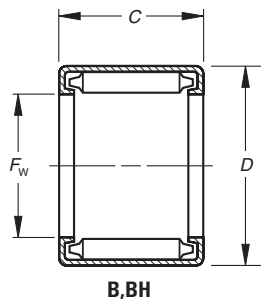

Drawn cup bearings of nominal inch dimensions, with one closed end, that are not tabulated, may be made available upon request.

Mounting dimensions are based on the inner ring rotating and the outer ring being stationary relative to the load. The housing should be of high strength material. See engineering section for discussion of shaft and housing design.

Shaft Dia.	Dimensions mm/in.				Bearing Designation		Load Ratings		Limiting Speed		C _g
	+0 +0.000 -0.3 -0.100						Dynamic	Static	Grease	Oil	
in.	F _w	D	C	Y			C	C ₀	RPM		
	15.875	22.212	15.88	—	BH-1010	—	16.4	25.3	4200	6500	0.0278
	0.6250	0.8745	0.625	—			3680	5680			
5/8	15.875	22.212	19.05	—	BH-1012	—	19.8	32.3	4200	6500	0.0295
	0.6250	0.8745	0.750	—			4450	7250			
	15.875	22.212	25.40	—	BH-1016	—	26.2	46.3	4200	6500	0.0322
	0.6250	0.8745	1.000	—			5890	10400			
11/16	17.463	22.212	9.53	2.03	B-116	M-1161	8.18	14.0	2700	4200	0.0263
	0.6875	0.8745	0.375	0.08			1840	3140			
	17.463	22.212	12.70	2.03	B-118	M-1181	11.5	21.7	2700	4200	0.0293
	0.6875	0.8745	0.500	0.08			2580	4880			
	17.463	22.212	15.88	2.03	B-1110	M-11101	14.6	29.4	2700	4200	0.0316
	0.6875	0.8745	0.625	0.08			3270	6610			
	17.463	22.212	19.05	2.03	B-1112	M-11121	17.4	37.1	2700	4200	0.0335
	0.6875	0.8745	0.750	0.08			3920	8340			
	17.463	23.813	11.13	—	BH-117	—	11.4	16.2	3900	6000	0.0259
	0.6875	0.9375	0.438	—			2560	3650			
	17.463	23.813	15.88	2.29	BH-1110	MH-11101	17.3	27.8	3900	6000	0.0296
	0.6875	0.9375	0.625	0.09			3890	6250			
	17.463	23.813	19.05	—	BH-1112	—	20.9	35.5	3900	6000	0.0314
	0.6875	0.9375	0.750	—			4700	7980			
3/4	19.050	25.400	9.53	2.29	B-126	M-1261	9.7	13.6	3600	5600	0.0256
	0.7500	1.0000	0.375	0.09			2180	3050			
	19.050	25.400	12.70	2.29	B-128	M-1281	14.1	22.0	3600	5600	0.0289
	0.7500	1.0000	0.500	0.09			3170	4940			
	19.050	25.400	15.88	2.29	B-1210	M-12101	18.2	30.3	3600	5600	0.0313
	0.7500	1.0000	0.625	0.09			4080	6820			
	19.050	25.400	19.05	2.29	B-1212	M-12121	21.9	38.7	3600	5600	0.0333
	0.7500	1.0000	0.750	0.09			4930	8710			
13/16	20.638	26.988	9.53	—	B-136	—	10.1	14.68	3400	5200	0.0271
	0.8125	1.0625	0.375	—			2280	3300			
	20.638	26.988	12.70	2.29	B-138	M-1381	14.8	23.80	3400	5200	0.0305
	0.8125	1.0625	0.500	0.09			3320	5350			
	20.638	26.988	22.23	2.29	B-1314	M-13141	26.7	51.15	3400	5200	0.0369
	0.8125	1.0625	0.875	0.09			6010	11500			
	20.638	26.988	25.40	2.29	B-1316	M-13161	30.3	60.05	3400	5200	0.0384
	0.8125	1.0625	1.000	0.09			6820	13500			
	20.638	26.988	31.75	—	B-1320	—	37.3	78.29	3500	5200	N/A
	0.8125	1.0625	1.250	—			8380	17600			
	20.643	28.575	12.70	2.79	BH-138	MH-1381	14.9	20.82	4100	6300	0.0287
	0.8127	1.1250	0.500	0.11			3340	4680			
	20.638	28.575	15.88	2.79	BH-1310	MH-13101	19.70	29.89	4100	6300	0.0314
	0.8125	1.1250	0.625	0.11			4430	6720			
	20.638	28.575	19.05	2.79	BH-1312	MH-13121	24.2	38.97	4100	6300	0.0336
	0.8125	1.1250	0.750	0.11			5440	8760			
7/8	22.225	28.575	9.53	2.29	B-146	M-1461	10.5	15.84	3100	4800	0.0285
	0.8750	1.1250	0.375	0.09			2370	3560			
	22.225	28.575	12.70	2.29	B-148	M-1481	15.4	25.62	3100	4800	0.0321
	0.8750	1.1250	0.500	0.09			3450	5760			
	22.225	28.575	19.05	2.29	B-1412	M-14121	23.9	45.37	3100	4800	0.0369
	0.8750	1.1250	0.750	0.09			5370	10200			
	22.225	28.575	25.40	2.29	B-1416	M-14161	31.6	64.94	3100	4800	0.0404
	0.8750	1.1250	1.000	0.09			7100	14600			

Wt. kg/lbs. Approx.		Bearing Mounting mm/in.				Inspection mm/in.			Matching Inner Ring*	Shaft Dia.
Open Ends	Closed Ends	Max.	Min.	Min.	Max.	Ring Gage	Plug-GO	Plug-NO-Go		
		S		H						in.
0.018 0.039	—	15.875 0.6250	15.862 0.6245	22.212 0.8745	22.238 0.8755	22.238 0.8755	15.913 0.6265	15.939 0.6275	IR-612-1	
0.021 0.047	—	15.875 0.6250	15.862 0.6245	22.212 0.8745	22.238 0.8755	22.238 0.8755	15.913 0.6265	15.939 0.6275	IR-612-1	5/8
0.028 0.062	—	15.875 0.6250	15.862 0.6245	22.212 0.8745	22.238 0.8755	22.238 0.8755	15.913 0.6265	15.939 0.6275		
0.008 0.018	0.009 0.020	17.463 0.6875	17.450 0.6870	22.212 0.8745	22.238 0.8755	22.238 0.8755	17.501 0.6890	17.526 0.6900		11/16
0.011 0.024	0.012 0.027	17.463 0.6875	17.450 0.6870	22.212 0.8745	22.238 0.8755	22.238 0.8755	17.501 0.6890	17.526 0.6900		
0.014 0.030	0.015 0.034	17.463 0.6875	17.450 0.6870	22.212 0.8745	22.238 0.8755	22.238 0.8755	17.501 0.6890	17.526 0.6900		
0.016 0.036	0.019 0.041	17.463 0.6875	17.450 0.6870	22.212 0.8745	22.238 0.8755	22.238 0.8755	17.501 0.6890	17.526 0.6900		
0.014 0.030	—	17.463 0.6875	17.450 0.6870	23.800 0.9370	23.825 0.9380	23.825 0.9380	17.501 0.6890	17.526 0.6900		
0.019 0.042	0.021 0.047	17.463 0.6875	17.450 0.6870	23.800 0.9370	23.825 0.9380	23.825 0.9380	17.501 0.6890	17.526 0.6900		
0.023 0.051	—	17.463 0.6875	17.450 0.6870	23.800 0.9370	23.825 0.9380	23.825 0.9380	17.501 0.6890	17.526 0.6900		
0.012 0.027	0.014 0.031	19.050 0.7500	19.037 0.7495	25.387 0.9995	25.413 1.0005	25.387 0.9995	19.063 0.7505	19.088 0.7515	IR-88	3/4
0.016 0.036	0.019 0.041	19.050 0.7500	19.037 0.7495	25.387 0.9995	25.413 1.0005	25.387 0.9995	19.063 0.7505	19.088 0.7515	IR-88	
0.020 0.045	0.024 0.052	19.050 0.7500	19.037 0.7495	25.387 0.9995	25.413 1.0005	25.387 0.9995	19.063 0.7505	19.088 0.7515		
0.024 0.054	0.028 0.062	19.050 0.7500	19.037 0.7495	25.387 0.9995	25.413 1.0005	25.387 0.9995	19.063 0.7505	19.088 0.7515	IR-812	
0.013 0.029	—	20.638 0.8125	20.625 0.8120	26.975 1.0620	27.000 1.0630	26.975 1.0620	20.650 0.8130	20.676 0.8140		13/16
0.018 0.039	0.020 0.044	20.638 0.8125	20.625 0.8120	26.975 1.0620	27.000 1.0630	26.975 1.0620	20.650 0.8130	20.676 0.8140		
0.031 0.068	0.035 0.077	20.638 0.8125	20.625 0.8120	26.975 1.0620	27.000 1.0630	26.975 1.0620	20.650 0.8130	20.676 0.8140		
0.035 0.078	0.040 0.088	20.638 0.8125	20.625 0.8120	26.975 1.0620	27.000 1.0630	26.975 1.0620	20.650 0.8130	20.676 0.8140		
0.044 0.098	—	20.638 0.8125	29.625 0.8120	27.000 1.0630	26.975 1.0620	26.975 1.0620	20.650 0.8130	20.676 0.8140		
0.023 0.050	0.026 0.057	20.638 0.8125	20.625 0.8120	28.562 1.1245	28.588 1.1255	28.562 1.1245	20.650 0.8130	20.676 0.8140		
0.029 0.063	0.032 0.071	20.638 0.8125	20.625 0.8120	28.562 1.1245	28.588 1.1255	28.562 1.1245	20.650 0.8130	20.676 0.8140		
0.034 0.076	0.039 0.086	20.638 0.8125	20.625 0.8120	28.562 1.1245	28.588 1.1255	28.562 1.1245	20.650 0.8130	20.676 0.8140		
0.014 0.031	0.016 0.035	22.225 0.8750	22.212 0.8745	28.562 1.1245	28.588 1.1255	28.562 1.1245	22.238 0.8755	22.263 0.8765		7/8
0.019 0.042	0.022 0.048	22.225 0.8750	22.212 0.8745	28.562 1.1245	28.588 1.1255	28.562 1.1245	22.238 0.8755	22.263 0.8765	IR-1012	
0.028 0.062	0.032 0.070	22.225 0.8750	22.212 0.8745	28.562 1.1245	28.588 1.1255	28.562 1.1245	22.238 0.8755	22.263 0.8765	IRA-10	
0.038 0.083	0.043 0.094	22.225 0.8750	22.212 0.8745	28.562 1.1245	28.588 1.1255	28.562 1.1245	22.238 0.8755	22.263 0.8765	IR-1016	

* Further reduces shaft diameter.

Continued on next page.



NEEDLE ROLLER BEARINGS

FULL COMPLEMENT BEARINGS, OPEN ENDS, CLOSED ONE END — *continued*

INCH SERIES

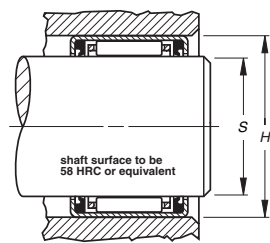
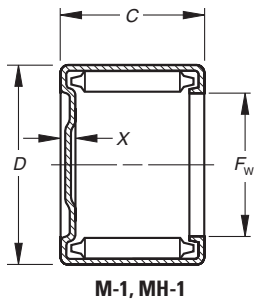
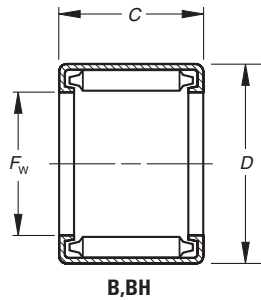

Drawn cup bearings of nominal inch dimensions, with one closed end, that are not tabulated, may be made available upon request.

Mounting dimensions are based on the inner ring rotating and the outer ring being stationary relative to the load. The housing should be of high strength material.

See engineering section for discussion of shaft and housing design.

Shaft Dia.	Dimensions mm/in.				Bearing Designation	Load Ratings		Limiting Speed		C _g
	F _w	D	C	Y		Dynamic	Static	Grease	Oil	
in.	F _w	D	C	Y		C	C ₀	RPM		
	22.225 0.8750	28.575 1.1250	28.58 1.125	—	B-1418 —	35.2 7920	74.73 16800	3100	4800	0.0418
	22.225 0.8750	30.163 1.1875	15.88 0.625	2.79 0.11	BH-1410 MH-14101	20.3 4570	32.21 7240	3800	5880	0.0331
	22.225 0.8750	30.163 1.1875	19.05 0.750	2.79 0.11	BH-1412 MH-14121	25.0 5620	41.99 9440	3800	5880	0.0354
	22.225 0.8750	30.163 1.1875	25.40 1.000	—	BH-1416 —	33.7 7570	61.39 13800	3800	5880	0.0389
15/16	23.813 0.9375	30.163 1.1875	12.70 0.500	—	B-158 —	15.9 3580	27.49 6180	3000	4500	0.0336
	23.813 0.9375	30.163 1.1875	25.40 1.000	2.29 0.09	B-1516 M-15161	32.8 7370	69.39 15600	3000	4500	0.0423
1/2	25.400 1.0000	31.750 1.2500	9.53 0.375	—	B-166 —	11.3 2550	18.10 4070	2800	4300	0.0312
	25.400 1.0000	31.750 1.2500	11.13 0.438	2.29 0.09	B-167 M-1671	14.0 3140	23.66 5320	2800	4300	0.0333
	25.400 1.0000	31.750 1.2500	15.88 0.625	2.29 0.09	B-1610 M-16101	21.2 4770	40.52 9110	2800	4300	0.0381
	25.400 1.0000	31.750 1.2500	19.05 0.750	2.29 0.09	B-1612 M-16121	25.7 5770	51.60 11600	2800	4300	0.0404
	25.400 1.0000	31.750 1.2500	25.40 1.000	2.29 0.09	B-1616 M-16161	33.9 7630	74.29 16700	2800	4300	0.0442
	25.400 1.0000	33.338 1.3125	12.70 0.500	2.79 0.11	BH-168 MH-1681	16.6 3740	25.6 5760	3400	5200	0.0330
	25.400 1.0000	33.338 1.3125	15.88 0.625	—	BH-1610 —	22.0 4950	36.8 8280	3400	5200	0.0361
	25.400 1.0000	33.338 1.3125	19.05 0.750	2.79 0.11	BH-1612 MH-16121	27.1 6090	48.0 10800	3400	5200	0.0386
	25.400 1.0000	33.338 1.3125	22.23 0.875	—	BH-1614 —	31.9 7170	59.2 13300	3400	5200	0.0407
	25.400 1.0000	33.338 1.3125	25.40 1.000	2.79 0.11	BH-1616 MH-16161	36.5 8200	70.3 15800	3400	5200	0.0425
	25.400 1.0000	33.338 1.3125	31.75 1.250	—	BH-1620 —	45.4 10200	93.0 20900	3400	5200	0.0455
	25.400 1.0000	33.338 1.3125	38.10 1.500	2.79 0.11	BH-1624 MH-16241	53.4 12000	115.2 25900	3400	5200	0.0480
1 1/16	26.988 1.0625	33.338 1.3125	15.88 0.625	2.29 0.09	B-1710 M-17101	21.9 4930	43.1 9680	2600	4000	0.0397
	26.988 1.0625	34.925 1.3750	19.05 0.750	—	BH-1712 —	29.49 6630	52.49 11800	2300	3400	N/A
1 1/8	28.575 1.1250	34.925 1.3750	9.53 0.375	2.29 0.09	B-186 M-1861	12.1 2720	20.37 4580	2500	3800	0.0338
	28.575 1.1250	34.925 1.3750	12.70 0.500	2.29 0.09	B-188 M-1881	17.6 3950	33.0 7420	2500	3800	0.0381
	28.575 1.1250	34.925 1.3750	15.88 0.625	—	B-1810 —	22.6 5080	45.8 10300	2500	3800	0.0413
	28.575 1.1250	34.925 1.3750	19.05 0.750	2.29 0.09	B-1812 M-18121	27.3 6140	58.3 13100	2500	3800	0.0438
	28.575 1.1250	34.925 1.3750	25.40 1.000	2.29 0.09	B-1816 M-18161	36.2 8130	83.6 18800	2500	3800	0.0479
	28.575 1.1250	38.100 1.5000	19.05 0.750	3.05 0.12	BH-1812 MH-18121	31.5 7090	52.9 11900	3600	5600	0.0405

Wt. kg/lbs. Approx.		Bearing Mounting mm/in.				Inspection mm/in.			Matching Inner Ring*	Shaft Dia.
Open Ends	Closed Ends	Max.	Min.	Min.	Max.	Ring Gage	Plug-GO	Plug-NO-Go		
		S		H						in.
0.043 0.094	—	22.225 0.8750	22.212 0.8745	28.562 1.1245	28.588 1.1255	28.562 1.1245	22.238 0.8755	22.263 0.8765		
0.030 0.067	0.035 0.076	22.225 0.8750	22.212 0.8745	30.150 1.1870	30.175 1.1880	30.150 1.1870	22.238 0.8755	22.263 0.8765	IR-1012	
0.036 0.080	0.041 0.091	22.225 0.8750	22.212 0.8745	30.150 1.1870	30.175 1.1880	30.150 1.1870	22.238 0.8755	22.263 0.8765	IRA-10	
0.049 0.107	—	22.225 0.8750	22.212 0.8745	30.150 1.1870	30.175 1.1880	30.150 1.1870	22.238 0.8755	22.263 0.8765	IR-1016	
0.020 0.044	—	23.813 0.9375	23.800 0.9370	30.150 1.1870	30.175 1.1880	30.150 1.1870	23.825 0.9380	23.851 0.9390		15/16
0.040 0.088	0.045 0.100	23.813 0.9375	23.800 0.9370	30.150 1.1870	30.175 1.1880	30.150 1.1870	23.825 0.9380	23.851 0.9390		
0.016 0.035	—	25.400 1.0000	25.387 0.9995	31.737 1.2495	31.763 1.2505	31.737 1.2495	25.413 1.0005	25.438 1.0015	IR-128	1/2
0.019 0.041	0.021 0.046	25.400 1.0000	25.387 0.9995	31.737 1.2495	31.763 1.2505	31.737 1.2495	25.413 1.0005	25.438 1.0015	IR-128	
0.026 0.058	0.030 0.066	25.400 1.0000	25.387 0.9995	31.737 1.2495	31.763 1.2505	31.737 1.2495	25.413 1.0005	25.438 1.0015	IR-1212	
0.032 0.070	0.036 0.080	25.400 1.0000	25.387 0.9995	31.737 1.2495	31.763 1.2505	31.737 1.2495	25.413 1.0005	25.438 1.0015	IR-1212	
0.043 0.094	0.048 0.106	25.400 1.0000	25.387 0.9995	31.737 1.2495	31.763 1.2505	31.737 1.2495	25.413 1.0005	25.438 1.0015	IR-1216	
0.027 0.060	0.031 0.068	25.400 1.0000	25.387 0.9995	33.325 1.3120	33.350 1.3130	33.325 1.3120	25.413 1.0005	25.438 1.0015	IR-128	
0.034 0.075	—	25.400 1.0000	25.387 0.9995	33.325 1.3120	33.350 1.3130	33.325 1.3120	25.413 1.0005	25.438 1.0015	IR-1212	
0.041 0.090	0.046 0.102	25.400 1.0000	25.387 0.9995	33.325 1.3120	33.350 1.3130	33.325 1.3120	25.413 1.0005	25.438 1.0015	IR-1212	
0.048 0.105	—	25.400 1.0000	25.387 0.9995	33.325 1.3120	33.350 1.3130	33.325 1.3120	25.413 1.0005	25.438 1.0015	IR-1216	
0.054 0.120	0.062 0.136	25.400 1.0000	25.387 0.9995	33.325 1.3120	33.350 1.3130	33.325 1.3120	25.413 1.0005	25.438 1.0015	IR-1216	
0.068 0.150	—	25.400 1.0000	25.387 0.9995	33.325 1.3120	33.350 1.3130	33.325 1.3120	25.413 1.0005	25.438 1.0015	IR-1220	
0.082 0.180	0.093 0.204	25.400 1.0000	25.387 0.9995	33.325 1.3120	33.350 1.3130	33.325 1.3120	25.413 1.0005	25.438 1.0015	IR-1224	
0.028 0.062	0.032 0.070	26.988 1.0625	26.975 1.0620	33.325 1.3120	33.350 1.3130	33.325 1.3120	27.000 1.0630	27.026 1.0640		1 1/16
0.035 0.078	—	26.988 1.0625	26.975 1.0620	34.912 1.3745	34.938 1.3755	33.325 1.3120	25.413 1.0005	25.438 1.0015		
0.018 0.039	0.020 0.044	28.575 1.1250	28.562 1.1245	34.912 1.3745	34.938 1.3755	34.912 1.3745	28.588 1.1255	28.613 1.1265		1 1/8
0.024 0.052	0.027 0.059	28.575 1.1250	28.562 1.1245	34.912 1.3745	34.938 1.3755	34.912 1.3745	28.588 1.1255	28.613 1.1265		
0.029 0.065	—	28.575 1.1250	28.562 1.1245	34.912 1.3745	34.938 1.3755	34.912 1.3745	28.588 1.1255	28.613 1.1265		
0.035 0.078	0.040 0.088	28.575 1.1250	28.562 1.1245	34.912 1.3745	34.938 1.3755	34.912 1.3745	28.588 1.1255	28.613 1.1265		
0.047 0.104	0.054 0.118	28.575 1.1250	28.562 1.1245	34.912 1.3745	34.938 1.3755	34.912 1.3745	28.588 1.1255	28.613 1.1265	IR-1416	
0.056 0.123	0.063 0.138	28.575 1.1250	28.562 1.1245	38.087 1.4995	38.113 1.5005	38.087 1.4995	28.588 1.1255	28.613 1.1265		

* Further reduces shaft diameter.

Continued on next page.



FULL COMPLEMENT BEARINGS,
OPEN ENDS, CLOSED ONE END – *continued*

INCH SERIES

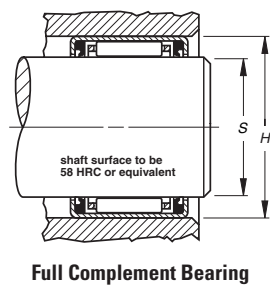
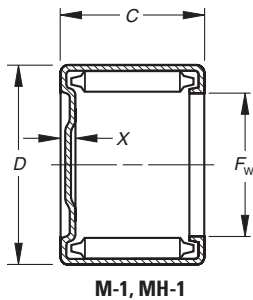
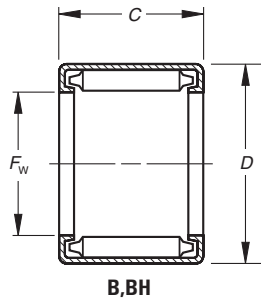

Drawn cup bearings of nominal inch dimensions, with one closed end, that are not tabulated, may be made available upon request.

Mounting dimensions are based on the inner ring rotating and the outer ring being stationary relative to the load. The housing should be of high strength material. See engineering section for discussion of shaft and housing design.

Shaft Dia.	Dimensions mm/in.				Bearing Designation		Load Ratings		Limiting Speed		C _g
	+0 +0.000 -0.3 -0.100						Dynamic	Static	Grease	Oil	
in.	F _w	D	C	Y	C	C ₀	RPM				
	28.575	38.100	25.40	3.05	BH-1816	MH-18161	42.5	77.8	3600	5600	0.0446
	1.1250	1.5000	1.000	0.12			9560	17500			
	28.575	38.100	31.75	3.05	BH-1820	MH-18201	52.9	103.2	3600	5600	0.0479
	1.1250	1.5000	1.250	0.12			11900	23200			
1 3/16	30.163	38.100	15.88	2.79	B-1910	M-19101	24.1	43.8	2900	4400	0.0406
	1.1875	1.5000	0.625	0.11			5420	9840			
	30.163	38.100	25.40	—	B-1916	—	40.0	83.6	2900	4400	0.0477
	1.1875	1.5000	1.000	—			8980	18800			
1 1/4	31.750	38.100	12.70	2.29	B-208	M-2081	18.6	36.6	2300	3500	0.0409
	1.2500	1.5000	0.500	0.09			4170	8240			
	31.750	38.100	15.88	2.29	B-2010	M-20101	23.9	50.7	2300	3500	0.0444
	1.2500	1.5000	0.625	0.09			5370	11400			
	31.750	38.100	19.05	2.29	B-2012	M-20121	28.9	64.5	2300	3500	0.0471
	1.2500	1.5000	0.750	0.09			6490	14500			
	31.750	38.100	25.40	2.29	B-2016	M-20161	38.2	92.5	2300	3500	0.0515
	1.2500	1.5000	1.000	0.09			8590	20800			
	31.750	38.100	31.75	2.29	B-2020	M-20201	47.2	121	2300	3500	0.0550
	1.2500	1.5000	1.250	0.09			10600	27200			
	31.750	41.275	12.70	3.05	BH-208	MH-2081	19.7	30	3300	5000	0.0369
	1.2500	1.6250	0.500	0.12			4420	6750			
	31.750	41.275	19.05	3.05	BH-2012	MH-20121	33.1	58.7	3300	5000	0.0435
	1.2500	1.6250	0.750	0.12			7440	13200			
	31.750	41.275	25.40	3.05	BH-2016	MH-20161	44.9	86.7	3300	5000	0.0480
	1.2500	1.6250	1.000	0.12			10100	19500			
	31.750	41.275	31.75	3.05	BH-2020	MH-20201	56.0	115	3300	5000	0.0515
	1.2500	1.6250	1.250	0.12			12600	25800			
1 5/16	33.338	41.275	12.70	2.79	B-218	M-2181	19.3	33.7	2600	4100	0.0397
	1.3125	1.6250	0.500	0.11			4330	7570			
	33.338	41.275	15.88	2.79	B-2110	M-21101	25.5	48.5	2600	4100	0.0435
	1.3125	1.6250	0.625	0.11			5740	10900			
	33.338	41.275	31.75	—	B-2120	—	52.5	122	2600	4100	0.0547
	1.3125	1.6250	1.250	—			11800	27500			
1 3/8	34.925	41.275	12.70	2.29	B-228	M-2281	19.5	40.4	2100	3200	0.0437
	1.3750	1.6250	0.500	0.09			4390	9070			
	34.925	41.275	19.05	2.29	B-2212	M-22121	30.4	71.2	2100	3200	0.0504
	1.3750	1.6250	0.750	0.09			6830	16000			
	34.925	41.275	25.40	2.29	B-2216	M-22161	40.2	102	2100	3200	0.0551
	1.3750	1.6250	1.000	0.09			9030	22900			
	34.925	41.275	31.75	2.29	B-2220	M-22201	49.4	133	2100	3200	0.0588
	1.3750	1.6250	1.250	0.09			11100	29900			
	34.925	44.450	12.70	—	BH-228	—	21.2	33.5	3000	4700	0.0394
	1.3750	1.7500	0.500	—			4770	7540			
	34.925	44.450	15.88	—	BH-2210	—	28.5	48.9	3000	4700	0.0432
	1.3750	1.7500	0.625	—			6410	11000			
	34.925	44.450	19.05	3.05	BH-2212	MH-22121	35.3	64.5	3000	4700	0.0463
	1.3750	1.7500	0.750	0.12			7930	14500			
	34.925	44.450	25.40	3.05	BH-2216	MH-22161	47.6	94.8	3000	4700	0.0509
	1.3750	1.7500	1.000	0.12			10700	21300			
	34.925	44.450	31.75	—	BH-2220	—	59.6	126	3000	4700	0.0547
	1.3750	1.7500	1.250	—			13400	28300			
1 1/2	38.100	47.625	12.70	3.05	B-248	M-2481	22.3	37.1	2800	4300	0.0420
	1.5000	1.8750	0.500	0.12			5020	8340			

Wt. kg/lbs. Approx.		Bearing Mounting mm/in.				Inspection mm/in.			Matching Inner Ring*	Shaft Dia.
Open Ends	Closed Ends	Max.	Min.	Min.	Max.	Ring Gage	Plug-GO	Plug-NO-Go		in.
		S		H						
0.074 0.164	0.084 0.186	28.575 1.1250	28.562 1.1245	38.087 1.4995	38.113 1.5005	38.087 1.4995	28.588 1.1255	28.613 1.1265	IR-1416	
0.093 0.205	0.105 0.232	28.575 1.1250	28.562 1.1245	38.087 1.4995	38.113 1.5005	38.087 1.4995	28.588 1.1255	28.613 1.1265		
0.040 0.088	0.045 0.099	30.163 1.1875	30.150 1.1870	38.087 1.4995	38.113 1.5005	38.087 1.4995	30.175 1.1880	30.201 1.1890		1 3/16
0.064 0.140	—	30.163 1.1875	30.150 1.1870	38.087 1.4995	38.113 1.5005	38.087 1.4995	30.175 1.1880	30.201 1.1890		
0.026 0.057	0.029 0.065	31.750 1.2500	31.737 1.2495	38.087 1.4995	38.113 1.5005	38.087 1.4995	31.763 1.2505	31.788 1.2515		1 1/4
0.032 0.071	0.044 0.097	31.750 1.2500	31.737 1.2495	38.087 1.4995	38.113 1.5005	38.087 1.4995	31.763 1.2505	31.788 1.2515		
0.039 0.086	0.045 0.099	31.750 1.2500	31.737 1.2495	38.087 1.4995	38.113 1.5005	38.087 1.4995	31.763 1.2505	31.788 1.2515	IR-1612	
0.052 0.114	0.059 0.130	31.750 1.2500	31.737 1.2495	38.087 1.4995	38.113 1.5005	38.087 1.4995	31.763 1.2505	31.788 1.2515	IR-1616	
0.065 0.143	0.073 0.162	31.750 1.2500	31.737 1.2495	38.087 1.4995	38.113 1.5005	38.087 1.4995	31.763 1.2505	31.788 1.2515		
0.041 0.090	0.046 0.102	31.750 1.2500	31.737 1.2495	41.262 1.6245	41.288 1.6255	41.262 1.6245	31.763 1.2505	31.788 1.2515		
0.061 0.135	0.069 0.153	31.750 1.2500	31.737 1.2495	41.262 1.6245	41.288 1.6255	41.262 1.6245	31.763 1.2505	31.788 1.2515	IR-1612	
0.081 0.179	0.092 0.203	31.750 1.2500	31.737 1.2495	41.262 1.6245	41.288 1.6255	41.262 1.6245	31.763 1.2505	31.788 1.2515	IR-1616	
0.102 0.224	0.115 0.254	31.750 1.2500	31.737 1.2495	41.262 1.6245	41.288 1.6255	41.262 1.6245	31.763 1.2505	31.788 1.2515		
0.034 0.076	0.039 0.086	33.338 1.3125	33.325 1.3120	41.262 1.6245	41.288 1.6255	41.262 1.6245	33.350 1.3130	33.378 1.3141		1 5/16
0.043 0.095	0.049 0.108	33.338 1.3125	33.325 1.3120	41.262 1.6245	41.288 1.6255	41.262 1.6245	33.350 1.3130	33.378 1.3141		
0.087 0.191	—	33.338 1.3125	33.325 1.3120	41.262 1.6245	41.288 1.6255	41.262 1.6245	33.350 1.3130	33.378 1.3141		
0.028 0.062	0.032 0.070	34.925 1.3750	34.912 1.3745	41.262 1.6245	41.288 1.6255	41.262 1.6245	34.938 1.3755	34.966 1.3766		1 3/8
0.043 0.094	0.049 0.107	34.925 1.3750	34.912 1.3745	41.262 1.6245	41.288 1.6255	41.262 1.6245	34.938 1.3755	34.966 1.3766	IR-1812	
0.057 0.125	0.064 0.142	34.925 1.3750	34.912 1.3745	41.262 1.6245	41.288 1.6255	41.262 1.6245	34.938 1.3755	34.966 1.3766	IR-1816	
0.071 0.156	0.080 0.177	34.925 1.3750	34.912 1.3745	41.262 1.6245	41.288 1.6255	41.262 1.6245	34.938 1.3755	34.966 1.3766	IR-1820	
0.044 0.098	—	34.925 1.3750	34.912 1.3745	44.437 1.7495	44.463 1.7505	44.437 1.7495	34.938 1.3755	34.966 1.3766		
0.055 0.122	—	34.925 1.3750	34.912 1.3745	44.437 1.7495	44.463 1.7505	44.437 1.7495	34.938 1.3755	34.966 1.3766	IR-1812	
0.066 0.146	0.075 0.165	34.925 1.3750	34.912 1.3745	44.437 1.7495	44.463 1.7505	44.437 1.7495	34.938 1.3755	34.966 1.3766	IR-1812	
0.088 0.195	0.100 0.221	34.925 1.3750	34.912 1.3745	44.437 1.7495	44.463 1.7505	44.437 1.7495	34.938 1.3755	34.966 1.3766	IR-1816	
0.111 0.244	0.125 0.276	34.925 1.3750	34.912 1.3745	44.437 1.7495	44.463 1.7505	44.437 1.7495	34.938 1.3755	34.966 1.3766	IR-1820	
0.048 0.105	0.054 0.119	38.100 1.5000	38.087 1.4995	47.612 1.8745	47.638 1.8755	47.612 1.8745	38.113 1.5005	38.143 1.5017		1 1/2

* Further reduces shaft diameter.

Continued on next page.



**FULL COMPLEMENT BEARINGS,
OPEN ENDS, CLOSED ONE END** – *continued*

INCH SERIES

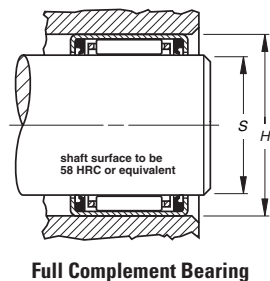
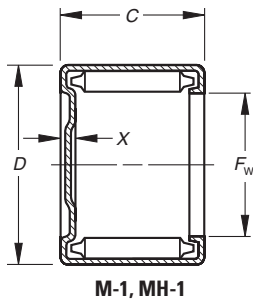
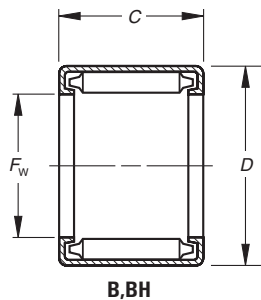

Drawn cup bearings of nominal inch dimensions, with one closed end, that are not tabulated, may be made available upon request.

Mounting dimensions are based on the inner ring rotating and the outer ring being stationary relative to the load. The housing should be of high strength material. See engineering section for discussion of shaft and housing design.

Shaft Dia.	Dimensions mm/in.				Bearing Designation		Load Ratings		Limiting Speed		C _g
	+0 +0.000 -0.3 -0.100						Dynamic	Static	Grease	Oil	
in.	F _w	D	C	Y	C	C ₀	RPM				
1 1/8	38.100	47.625	15.88	3.05	B-2410	M-24101	29.8	53.8	2800	4300	0.0460
	1.5000	1.8750	0.625	0.12			6710	12100			
1 1/8	38.100	47.625	19.05	3.05	B-2412	M-24121	36.9	70.7	2800	4300	0.0493
	1.5000	1.8750	0.750	0.12			8290	15900			
1 1/8	38.100	47.625	22.23	3.05	B-2414	M-24141	43.5	87.6	2800	4300	0.0519
	1.5000	1.8750	0.875	0.12			9780	19700			
1 1/8	38.100	47.625	25.40	3.05	B-2416	M-24161	49.8	103	2800	4300	0.0542
	1.5000	1.8750	1.000	0.12			11200	23300			
1 1/8	38.100	47.625	31.75	3.05	B-2420	M-24201	61.8	138	2800	4300	0.0581
	1.5000	1.8750	1.250	0.12			13900	31000			
1 5/8	41.275	50.800	12.70	—	B-268	—	22.8	39.2	2600	3900	0.0441
	1.6250	2.0000	0.500	—			5120	8820			
1 5/8	41.275	50.800	15.88	3.05	B-2610	M-26101	30.6	57.4	2600	3900	0.0485
	1.6250	2.0000	0.625	0.12			6890	12900			
1 5/8	41.275	50.800	25.40	—	B-2616	—	51.6	112	2600	3900	0.0573
	1.6250	2.0000	1.000	—			11600	25200			
1 5/8	41.275	50.800	31.75	3.05	B-2620	M-26201	64.0	149	2600	3900	0.0614
	1.6250	2.0000	1.250	0.12			14400	33400			
1 3/4	44.450	53.975	19.05	3.05	B-2812	M-28121	39.3	81.4	2400	3700	0.0547
	1.7500	2.1250	0.750	0.12			8830	18300			
1 3/4	44.450	53.975	25.40	3.05	B-2816	M-28161	53.4	121	2400	3700	0.0603
	1.7500	2.1250	1.000	0.12			12000	27100			
1 3/4	44.450	53.975	31.75	—	B-2820	—	66.3	160	2400	3700	0.0647
	1.7500	2.1250	1.250	—			14900	36000			
1 7/8	44.450	53.975	38.10	3.05	B-2824	M-26241	78.7	199	2400	3700	0.0683
	1.7500	2.1250	1.500	0.12			17700	44800			
1 7/8	47.625	57.150	12.70	3.05	B-308	M-3081	25.1	46.3	2300	3500	0.0489
	1.8750	2.2500	0.500	0.12			5650	10400			
1 7/8	47.625	57.150	15.888	—	B-3010	—	33.6	67.61	2300	3500	N/A
	1.8750	2.2500	0.625	—			7550	15200			
1 7/8	47.625	57.150	19.05	—	B-3012	—	41.5	88.5	2300	3500	0.0574
	1.8750	2.2500	0.750	—			9330	19900			
1 7/8	47.625	57.150	25.40	3.05	B-3016	M-30161	56.0	130	2300	3500	0.0632
	1.8750	2.2500	1.000	0.12			12600	29200			
2	50.800	60.325	12.70	3.05	B-328	M-3281	25.4	48.0	2100	3300	0.0509
	2.0000	2.3750	0.500	0.12			5710	10800			
2	50.800	60.325	15.88	—	B-3210	—	34.2	70.7	2200	3300	N/A
	2.0000	2.3750	0.625	—			7680	15900			
2	50.800	60.325	22.23	—	B-3214	—	54.3	115	2200	3300	N/A
	2.0000	2.3750	0.875	—			11300	26000			
2	50.800	60.325	25.40	3.05	B-3216	M-32161	57.4	138	2100	3300	0.0661
	2.0000	2.3750	1.000	0.12			12900	31000			
2	50.800	60.325	31.75	3.05	B-3220	M-32201	71.6	183	2100	3300	0.0708
	2.0000	2.3750	1.250	0.12			16100	41100			
2	50.800	60.325	38.10	3.05	B-3224	M-32241	85.0	228	2100	3300	0.0748
	2.0000	2.3750	1.500	0.12			19100	51200			
2	50.800	60.325	44.45	3.05	B-3228	M-32281	97.4	273	2100	3300	0.0782
	2.0000	2.3750	1.750	0.12			21900	61300			
2 1/16	52.388	64.292	19.05	—	BH-3312	—	46.3	86.7	2600	4100	0.0574
	2.0625	2.5312	0.750	—			10400	19500			

Wt. kg/lbs. Approx.		Bearing Mounting mm/in.				Inspection mm/in.			Matching Inner Ring*	Shaft Dia. in.
Open Ends	Closed Ends	Max.	Min.	Min.	Max.	Ring Gage	Plug-GO	Plug-NO-Go		
		S		H						
0.060 0.132	0.068 0.150	38.100 1.5000	38.087 1.4995	47.612 1.8745	47.638 1.8755	47.612 1.8745	38.113 1.5005	38.143 1.5017		
0.072 0.158	0.081 0.179	38.100 1.5000	38.087 1.4995	47.612 1.8745	47.638 1.8755	47.612 1.8745	38.113 1.5005	38.143 1.5017		
0.083 0.184	0.095 0.209	38.100 1.5000	38.087 1.4995	47.612 1.8745	47.638 1.8755	47.612 1.8745	38.113 1.5005	38.143 1.5017		
0.096 0.211	0.108 0.239	38.100 1.5000	38.087 1.4995	47.612 1.8745	47.638 1.8755	47.612 1.8745	38.113 1.5005	38.143 1.5017	IR-1916	
0.119 0.263	0.135 0.298	38.100 1.5000	38.087 1.4995	47.612 1.8745	47.638 1.8755	47.612 1.8745	38.113 1.5005	38.143 1.5017	IR-1920	
0.051 0.113	—	41.275 1.6250	41.262 1.6245	50.787 1.9995	50.813 2.0005	50.787 1.9995	41.288 1.6255	41.318 1.6267		1 5/8
0.064 0.141	0.073 0.16	41.275 1.6250	41.262 1.6245	50.787 1.9995	50.813 2.0005	50.787 1.9995	41.288 1.6255	41.318 1.6267		
0.103 0.226	—	41.275 1.6250	41.262 1.6245	50.787 1.9995	50.813 2.0005	50.787 1.9995	41.288 1.6255	41.318 1.6267		
0.128 0.282	0.145 0.32	41.275 1.6250	41.262 1.6245	50.787 1.9995	50.813 2.0005	50.787 1.9995	41.288 1.6255	41.318 1.6267	IR-2220	
0.082 0.181	0.093 0.205	44.450 1.7500	44.437 1.7495	53.962 2.1245	53.988 2.1255	53.962 2.1245	44.463 1.7505	44.496 1.7518		1 3/4
0.110 0.242	0.124 0.274	44.450 1.7500	44.437 1.7495	53.962 2.1245	53.988 2.1255	53.962 2.1245	44.463 1.7505	44.496 1.7518	IR-2316	
0.137 0.302	—	44.450 1.7500	44.437 1.7495	53.962 2.1245	53.988 2.1255	53.962 2.1245	44.463 1.7505	44.496 1.7518		
0.165 0.363	0.186 0.411	44.450 1.7500	44.437 1.7495	53.962 2.1245	53.988 2.1255	53.962 2.1245	44.463 1.7505	44.496 1.7518	IR-2324	
0.059 0.129	0.066 0.146	47.625 1.8750	47.612 1.8745	57.137 2.2495	57.163 2.2505	57.137 2.2495	47.638 1.8755	47.671 1.8768		1 7/8
0.073 0.161	—	47.625 1.8750	47.612 1.8745	57.137 2.2495	57.163 2.2505	57.137 2.2495	47.638 1.8755	47.671 1.8768		
0.088 0.193	—	47.625 1.8750	47.612 1.8745	57.137 2.2495	57.163 2.2505	57.137 2.2495	47.638 1.8755	47.671 1.8768		
0.117 0.258	0.132 0.292	47.625 1.8750	47.612 1.8745	57.137 2.2495	57.163 2.2505	57.137 2.2495	47.638 1.8755	47.671 1.8768		
0.062 0.136	0.070 0.154	50.800 2.0000	50.785 1.9994	60.312 2.3745	60.338 2.3755	60.312 2.3745	50.815 2.0006	50.848 2.0019		2
0.078 0.171	—	50.800 2.0000	50.785 1.9994	60.312 2.3745	60.338 2.3755	60.312 2.3745	50.815 2.0006	50.848 2.0019		
0.108 0.239	—	50.800 2.0000	50.785 1.9994	60.312 2.3745	60.338 2.3755	60.312 2.3745	50.815 2.0006	50.848 2.0019		
0.124 0.273	0.140 0.309	50.800 2.0000	50.785 1.9994	60.312 2.3745	60.338 2.3755	60.312 2.3745	50.815 2.0006	50.848 2.0019		
0.155 0.341	0.175 0.386	50.800 2.0000	50.785 1.9994	60.312 2.3745	60.338 2.3755	60.312 2.3745	50.815 2.0006	50.848 2.0019		
0.186 0.410	0.211 0.465	50.800 2.0000	50.785 1.9994	60.312 2.3745	60.338 2.3755	60.312 2.3745	50.815 2.0006	50.848 2.0019		
0.217 0.478	0.245 0.541	50.800 2.0000	50.785 1.9994	60.312 2.3745	60.338 2.3755	60.312 2.3745	50.815 2.0006	50.848 2.0019		
0.122 0.269	—	52.388 2.0625	52.372 2.0619	64.280 2.5307	64.305 2.5317	64.280 2.5307	50.815 2.0006	50.848 2.0019	IR-2916	2 1/16

* Further reduces shaft diameter.

Continued on next page.



**FULL COMPLEMENT BEARINGS,
OPEN ENDS, CLOSED ONE END** – *continued*

INCH SERIES

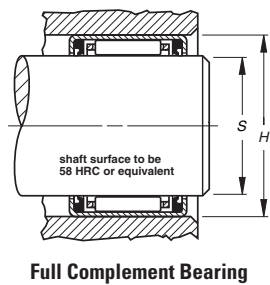
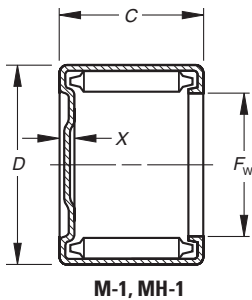
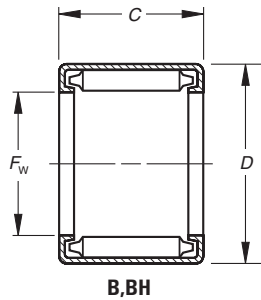

Shaft Dia.	Dimensions mm/in.				Bearing Designation		Load Ratings		Limiting Speed		C _g
	F _w	D	C	Y			Dynamic	Static	Grease	Oil	
in.	F _w	D	C	Y	C	C ₀	RPM				
	52.388	64.292	25.40	3.56	BH-3316 MH-33161	64.0	133	2600	4100	0.0639	
	2.0625	2.5312	1.000	0.14		14400	29900				
2 1/8	52.388	64.292	38.10	3.56	BH-3324 MH-33241	97.0	226	2600	4100	0.0728	
	2.0625	2.5312	1.500	0.14		21800	50700				
2 1/8	53.975	63.500	12.70	—	B-348 —	26.1	51.2	2000	3100	0.0531	
	2.1250	2.5000	0.500	—		5870	11500				
2 1/8	53.975	63.500	19.05	—	B-3412 —	43.6	99.2	2100	3100	N/A	
	2.1250	2.5000	0.750	—		9790	22300				
2 1/8	53.975	63.500	25.40	3.05	B-3416 M-34161	59.2	147	2000	3100	0.069	
	2.1250	2.5000	1.000	0.12		13300	33000				
2 1/8	53.975	63.500	31.75	—	B-3420 —	73.4	194	2000	3100	0.074	
	2.1250	2.5000	1.250	—		16500	43700				
2 1/8	53.975	63.500	38.10	3.05	B-3424 M-34241	87.2	242	2000	3100	0.0781	
	2.1250	2.5000	1.500	0.12		19600	54400				
2 1/4	57.150	66.675	19.05	3.30	B-3612 M-36121	45.8	105	2000	3000	0.0648	
	2.2500	2.6250	0.750	0.13		10300	23700				
2 1/4	57.150	66.675	31.75	—	B-3620 —	77.4	206	2000	3000	0.0766	
	2.2500	2.6250	1.250	—		17400	46400				
2 1/4	57.150	66.675	38.10	3.30	B-3624 M-36241	92.1	257	2000	3000	0.0809	
	2.2500	2.6250	1.500	0.13		20700	57700				
2 5/8	66.675	76.200	25.40	3.30	B-4216 M-42161	66.7	182	1700	2500	0.0799	
	2.6250	3.0000	1.000	0.13		15000	40900				
2 3/4	69.850	79.375	15.88	—	B-4410 —	41.0	98	1600	2500	0.0698	
	2.7500	3.1250	0.625	—		9210	22000				
2 3/4	69.850	79.375	25.40	—	B-4416 —	69.0	190	1600	2500	0.0824	
	2.7500	3.1250	1.000	—		15500	42800				
2 3/4	69.850	79.375	31.75	3.30	B-4420 M-44201	85.4	252	1600	2500	0.0883	
	2.7500	3.1250	1.250	0.13		19200	56700				
3 1/2	88.900	101.600	19.05	—	B-5612 —	64.9	150	1800	2700	N/A	
	3.5000	4.0000	0.750	—		14600	33700				
5 1/2	139.700	152.400	19.05	—	B-8812 —	77.00	231	1000	1600	0.114	
	5.5000	6.0000	0.750	—		17300	52000				

Drawn cup bearings of nominal inch dimensions, with one closed end, that are not tabulated, may be made available upon request.

Mounting dimensions are based on the inner ring rotating and the outer ring being stationary relative to the load. The housing should be of high strength material. See engineering section for discussion of shaft and housing design.

Wt. kg/lbs. Approx.		Bearing Mounting mm/in.				Inspection mm/in.			Matching Inner Ring*	Shaft Dia.
Open Ends	Closed Ends	Max.	Min.	Min.	Max.	Ring Gage	Plug-GO	Plug-NO-Go		
		S		H						in.
0.162 0.358	0.184 0.406	52.388 2.0625	52.372 2.0619	64.280 2.5307	64.305 2.5317	64.280 2.5307	50.815 2.0006	50.848 2.0019	IR-2916	
0.244 0.537	0.276 0.609	52.388 2.0625	52.372 2.0619	64.280 2.5307	64.305 2.5317	64.280 2.5307	50.815 2.0006	50.848 2.0019	IR-2724	
0.065 0.144	—	53.975 2.1250	53.960 2.1244	63.487 2.4995	63.513 2.5005	63.487 2.4995	53.990 2.1256	54.028 2.1271		2 1/8
0.098 0.216	—	53.975 2.1250	53.960 2.1244	63.487 2.4995	63.513 2.5005	63.487 2.4995	53.990 2.1256	54.028 2.1271		
0.131 0.289	0.148 0.327	53.975 2.1250	53.960 2.1244	63.487 2.4995	63.513 2.5005	63.487 2.4995	53.990 2.1256	54.028 2.1271		
0.164 0.361	—	53.975 2.1250	53.960 2.1244	63.487 2.4995	63.513 2.5005	63.487 2.4995	53.990 2.1256	54.028 2.1271		
0.196 0.433	0.223 0.491	53.975 2.1250	53.960 2.1244	63.487 2.4995	63.513 2.5005	63.487 2.4995	53.990 2.1256	54.028 2.1271	IR-3024	
0.103 0.228	0.117 0.258	57.150 2.2500	57.135 2.2494	66.662 2.6245	66.688 2.6255	66.662 2.6245	57.165 2.2506	57.203 2.2521		2 1/4
0.172 0.380	—	57.150 2.2500	57.135 2.2494	66.662 2.6245	66.688 2.6255	66.662 2.6245	57.165 2.2506	57.203 2.2521		
0.207 0.456	0.235 0.517	57.150 2.2500	57.135 2.2494	66.662 2.6245	66.688 2.6255	66.662 2.6245	57.165 2.2506	57.203 2.2521		
0.159 0.351	0.181 0.398	66.675 2.6250	66.660 2.6244	76.187 2.9995	76.213 3.0005	76.187 2.9995	66.700 2.6260	66.739 2.6275		2 5/8
0.104 0.229	—	69.850 2.7500	69.835 2.7494	79.362 3.1245	79.388 3.1255	79.362 3.1245	69.875 2.7510	69.914 2.7525		2 3/4
0.166 0.366	—	69.850 2.7500	69.835 2.7494	79.362 3.1245	79.388 3.1255	79.362 3.1245	69.875 2.7510	69.914 2.7525	IR-4016	
0.208 0.458	0.235 0.519	69.850 2.7500	69.835 2.7494	79.362 3.1245	79.388 3.1255	79.362 3.1245	69.875 2.7510	69.914 2.7525		
0.212 0.468	—	88.900 3.5000	88.885 3.4994	101.587 3.9995	101.613 4.0005	101.587 3.9995	88.925 3.5010	88.964 3.5025		3 1/2
0.325 0.717	—	139.700 5.5000	139.682 5.4993	152.375 5.9990	152.425 6.0010	152.375 5.9990	139.725 5.5010	139.776 5.5030		5 1/2

* Further reduces shaft diameter.





EXTRA-PRECISION BEARINGS –

INCH SERIES

Open end full complement mechanically retained drawn cup needle roller bearings, manufactured to inch standards, are offered with extra-precision specifications. The manufacturing tolerance of these bearings is one-third that of the precision bearings. In production operations using closer tolerances on shaft and housing, they will assemble with consistently lower radial internal clearances than can be expected with the precision series bearings.

Extra-precision bearings are suitable for those applications requiring close control of radial play and eccentricity. They are also preferred when two bearings are mounted adjacent to each other since the greater accuracy in manufacture will provide better load distribution between the bearings.

Nominal dimensions, load ratings, limiting speeds and other general specifications for extra-precision bearings are the same as for the corresponding “B” or “BH” sizes of drawn cup needle bearings. Consequently, the data on pages C66 to C79 can be used in bearing size selection.

When ordering an extra-precision bearing, add the prefix letter “G” to the bearing designation. For example, after following the size selection procedure outlined in the engineering section, bearing B-1212 is selected, but extra-precision tolerances are required. These are designated by ordering a GB-1212 bearing.

To realize the advantages of the expected closer radial internal clearance of the extra-precision bearing, the user must have the capability of producing housing bore and shaft raceway diameters to the close tolerances indicated by the tabular data on the facing page.

The resulting total radial internal clearance within the installed GB-1212 extra-precision drawn cup needle roller bearing will lie in the range from 0.0002 in. to 0.0012 in.

Inspection dimensions for the extra-precision bearings are given in the table at the right. Note that these bearings must be inspected while mounted in the specified ring gage. Bearing bores are checked with “GO” and “NO GO” plug gages. The “GO” gage size is the minimum diameter inside the needle rollers. The “NO GO” gage size is 0.0001 in. larger than the maximum diameter inside the needle rollers.

Procedures for selecting ring and plug gage dimensions are the same as for those involving precision needle bearings, except that the ring gage diameters and diameters inside the needle rollers must be drawn from the table on this page.

Nominal Inch Shaft Diameter	Gaging		
	Ring Gage	Diameter Inside Needle Rollers	
		Min.	Max.
1/8	0.2473	0.1256	0.1260
5/32	0.2785	0.1569	0.1573
3/16	0.3390	0.1881	0.1885
1/4	0.4328	0.2506	0.2510
5/16	0.4953	0.3131	0.3135
H 5/16	0.5578	0.3131	0.3135
3/8	0.5578	0.3756	0.3760
H 3/8	0.6203	0.3756	0.3760
7/16	0.6203	0.4381	0.4385
H 7/16	0.6828	0.4381	0.4385
1/2	0.6828	0.5006	0.5010
H 1/2	0.7453	0.5006	0.5010
9/16	0.7453	0.5631	0.5635
H 9/16	0.8078	0.5631	0.5635
5/8	0.8078	0.6256	0.6260
H 5/8	0.8703	0.6256	0.6260
11/16	0.8703	0.6881	0.6885
H 11/16	0.9328	0.6881	0.6885
3/4	0.9950	0.7503	0.7507
H 3/4	1.0575	0.7503	0.7507
13/16	1.0575	0.8128	0.8132
H 13/16	1.1200	0.8128	0.8132
7/8	1.1200	0.8753	0.8757
H 7/8	1.1825	0.8753	0.8757
15/16	1.1825	0.9378	0.9382
H 1	1.2450	1.0003	1.0007
H 1	1.3075	1.0003	1.0007
1 1/16	1.3075	1.0628	1.0632
1 1/8	1.3700	1.1253	1.1257
H 1 1/8	1.4950	1.1253	1.1257
1 3/16	1.4950	1.1878	1.1882
1 1/4	1.4950	1.2503	1.2507
H 1 1/4	1.6200	1.2503	1.2507
1 5/16	1.6200	1.3128	1.3132
1 3/8	1.6200	1.3753	1.3757
H 1 3/8	1.7450	1.3753	1.3757
1 1/2	1.8700	1.5003	1.5008
1 5/8	1.9950	1.6253	1.6258
1 3/4	2.1200	1.7503	1.7508
1 7/8	2.2450	1.8753	1.8758
2	2.3700	2.0003	2.0008
H 2 1/16	2.5262	2.0628	2.0633
2 1/8	2.4950	2.1253	2.1258
2 1/4	2.6200	2.2503	2.2508
2 5/8	2.9950	2.6254	2.6260
2 3/4	3.1200	2.7504	2.7510
3 1/2	3.9950	3.5004	3.5010

Bearing Bore Designation	Mounting					
	Nominal Bore Inch	Nominal O.D. Inch	Shaft Raceway Diameter		Housing Bore	
			Max.	Min.	Min.	Max.
GB-2	.1250	.2500	0.1251	0.1248	0.2470	0.2473
GB-2 1/2	.1562	.2812	0.1564	0.1561	0.2782	0.2785
GB-3	.1875	.3438	0.1876	0.1873	0.3387	0.3390
GB-4	.2500	.4375	0.2501	0.2498	0.4325	0.4328
GB-5	.3125	.5000	0.3126	0.3123	0.4950	0.4953
GBH-5	.3125	.5625	0.3126	0.3123	0.5575	0.5578
GB-6	.3750	.5625	0.3751	0.3748	0.5575	0.5578
GBH-6	.3750	.6250	0.3751	0.3748	0.6200	0.6203
GB-7	.4375	.6250	0.4376	0.4373	0.6200	0.6203
GBH-7	.4375	.6875	0.4376	0.4373	0.6825	0.6828
GB-8	.5000	.6875	0.5001	0.4998	0.6825	0.6828
GBH-8	.5000	.7500	0.5001	0.4998	0.7450	0.7453
GB-9	.5625	.7500	0.5626	0.5623	0.7450	0.7453
GBH-9	.5625	.8125	0.5626	0.5623	0.8075	0.8078
GB-10	.6250	.8125	0.6251	0.6248	0.8075	0.8078
GBH-10	.6250	.8750	0.6251	0.6248	0.8700	0.8703
GB-11	.6875	.8750	0.6876	0.6873	0.8700	0.8703
GBH-11	.6875	.9375	0.6876	0.6873	0.9325	0.9328
GB-12	.7500	1.0000	0.7501	0.7498	0.9950	0.9953
GBH-12	.7500	1.0625	0.7501	0.7498	1.0575	1.0578
GB-13	.8125	1.0625	0.8126	0.8123	1.0575	1.0578
GBH-13	.8125	1.1250	0.8126	0.8123	1.1200	1.1203
GB-14	.8750	1.1250	0.8751	0.8748	1.1200	1.1203
GBH-14	.8750	1.1875	0.8751	0.8748	1.1825	1.1829
GB-15	.9375	1.1875	0.9376	0.9373	1.1825	1.1829
GB-16	1.0000	1.2500	1.0001	0.9998	1.2450	1.2454
GBH-16	1.0000	1.3125	1.0001	0.9998	1.3075	1.3079
GB-17	1.0625	1.3125	1.0626	1.0623	1.3075	1.3079
GB-18	1.1250	1.3750	1.1251	1.1248	1.3700	1.3704
GBH-18	1.1250	1.5000	1.1251	1.1248	1.4950	1.4955
GB-19	1.1875	1.5000	1.1876	1.1873	1.4950	1.4955
GB-20	1.2500	1.5000	1.2501	1.2498	1.4950	1.4955
GBH-20	1.2500	1.6250	1.2501	1.2498	1.6200	1.6205
GB-21	1.3125	1.6250	1.3126	1.3123	1.6200	1.6205
GB-22	1.3750	1.6250	1.3750	1.3747	1.6200	1.6205
GBH-22	1.3750	1.7500	1.3750	1.3747	1.7450	1.7455
GB-24	1.5000	1.8750	1.5000	1.4997	1.8700	1.8705
GB-26	1.6250	2.0000	1.6250	1.6247	1.9950	1.9955
GB-28	1.7500	2.1250	1.7500	1.7497	2.1200	2.1205
GB-30	1.8750	2.2500	1.8750	1.8747	2.2450	2.2455
GB-32	2.0000	2.3750	2.0000	1.9997	2.3700	2.3705
GBH-33	2.0625	2.5312	2.0624	2.0621	2.5262	2.5267
GB-34	2.1250	2.5000	2.1249	2.1246	2.4950	2.4955
GB-36	2.2500	2.6250	2.2499	2.2496	2.6200	2.6205
GB-42	2.6250	3.0000	2.6248	2.6245	2.9950	2.9956
GB-44	2.7500	3.1250	2.7498	2.7495	3.1200	3.1206
GB-56	3.5000	4.0000	3.4998	3.4995	3.9950	3.9956

* Check for availability as not every size may be in production.





**CAGED BEARINGS –
OPEN ENDS, CLOSED ONE END**

INCH SERIES

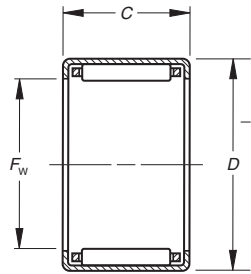

J, JH

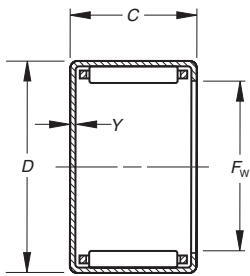

MJ-1, MJH-1

Mounting dimensions are based on the inner ring rotating and the outer ring being stationary relative to the load. The housing should be of high strength material.

See engineering section for discussion of shaft and housing design. See page C62 for mounting procedure.

Shaft Diameter	Dimensions mm/in. +0 +0.000 -0.3 -0.100				Bearing Designation		Load Ratings kN/lbf.		Limiting Speed		C _g	
	in.	F _w	D	C	Y	C	C ₀	Grease RPM	Oil RPM			
1/8	3.175	6.350	4.780	—	—	JP-23-F	—	0.89	0.62	33000	51000	0.0064
	0.1250	0.2500	0.188					200	140			
5/32	3.970	7.142	4.780	—	—	JP-2-1/2-3F	—	0.93	0.62	31000	47000	0.007
	0.1563	0.2812	0.188					210	140			
3/16	4.763	8.733	9.530	1.02	—	J-36 MJ-361	—	2.27	1.91	25000	38000	0.0097
	0.1875	0.3438	0.375	0.04				510	430			
1/4	6.350	11.113	7.920	1.02	—	J-45 MJ-451	—	2.22	1.73	20000	30000	0.0103
	0.2500	0.4375	0.312	0.04				500	390			
—	6.350	11.113	11.130	1.02	—	J-47 MJ-471	—	3.38	3.02	20000	30000	0.0119
	0.2500	0.4375	0.438	0.04				760	680			
5/16	7.938	12.700	7.920	—	—	J-55	—	2.40	2.00	18000	28000	0.0117
	0.3125	0.5000	0.312					—	540	450		
—	7.938	12.700	11.130	1.02	—	J-57 MJ-571	—	4.05	3.91	18000	28000	0.013
	0.3125	0.5000	0.438	0.04				910	880			
—	7.938	14.288	11.130	1.02	—	JH-57 MJH-571	—	4.63	3.78	14000	22000	0.0132
	0.3125	0.5625	0.438	0.04				1040	850			
3/8	9.525	14.288	7.920	1.02	—	J-65 MJ-651	—	2.76	2.49	18000	27000	0.0133
	0.3750	0.5625	0.312	0.04				620	560			
—	9.525	14.288	9.530	1.02	—	J-66 MJ-661	—	3.51	3.47	18000	27000	0.0144
	0.3750	0.5625	0.375	0.04				790	780			
—	9.525	14.288	12.700	1.02	—	J-68 MJ-681	—	5.20	5.74	18000	27000	0.0163
	0.3750	0.5625	0.500	0.04				1170	1290			
—	9.525	15.875	12.700	—	—	JH-68	—	6.58	6.09	13000	20000	0.0159
	0.3750	0.6250	0.500					—	1480	1370		
7/16	11.113	15.875	12.700	1.02	—	J-78 MJ-781	—	6.36	7.70	17000	26000	0.0187
	0.4375	0.6250	0.500	0.04				1430	1730			
—	11.113	17.463	12.700	—	—	JH-78	—	7.12	6.89	13000	19000	0.0174
	0.4375	0.6875	0.500					—	1600	1550		
1/2	12.700	17.463	7.920	1.02	—	J-85 MJ-851	—	3.47	3.65	16000	25000	0.0164
	0.5000	0.6875	0.312	0.04				780	820			
—	12.700	17.463	9.530	1.02	—	J-86 MJ-861	—	4.67	5.38	16000	25000	0.0181
	0.5000	0.6875	0.375	0.04				1050	1210			
—	12.700	17.463	12.700	1.02	—	J-88 MJ-881	—	6.32	7.92	16000	25000	0.0199
	0.5000	0.6875	0.500	0.04				1420	1780			
—	12.700	17.463	19.050	—	—	J-812	—	10.23	14.72	16000	25000	0.0232
	0.5000	0.6875	0.750					—	2300	3310		
—	12.700	19.050	11.130	1.02	—	JH-87 MJH-871	—	6.41	6.18	12000	19000	0.0179
	0.5000	0.7500	0.438	0.04				1440	1390			
—	12.700	19.050	12.700	1.02	—	JH-88 MJH-881	—	7.56	7.70	12000	19000	0.0189
	0.5000	0.7500	0.500	0.04				1700	1730			
—	12.700	19.050	19.050	—	—	JH-812	—	12.32	14.41	12000	19000	0.0221
	0.5000	0.7500	0.750					—	2770	3240		
9/16	14.288	19.050	11.130	1.02	—	J-97 MJ-971	—	5.47	6.81	16000	25000	—
	0.5625	0.750	0.438	0.04				1230	1530			
—	14.288	19.050	12.700	1.02	—	J-98 MJ-981	—	6.23	8.01	16000	25000	0.021
	0.5625	0.7500	0.500	0.04				1400	1800			

Wt. kg/lbs. Approx.		Bearing Mounting mm/in.				Inspection mm/in.			Matching Inner Ring	Shaft Diameter
Open Ends	Closed Ends	Max.	Min.	Min.	Max.	Ring Gage	Plug-GO	Plug-NO-Go		
		S		H						in.
0.0005 0.001	—	3.175 0.1250	3.167 0.1247	6.350 0.2500	6.363 0.2505	6.363 0.2505	3.195 0.1258	3.221 0.1268		1/8
0.0005 0.001	—	3.970 0.1563	3.962 0.1560	7.142 0.2812	7.155 0.2817	7.155 0.2817	3.990 0.1571	4.016 0.1581		5/32
0.0018 0.004	0.0023 0.005	4.763 0.1875	4.755 0.1872	8.717 0.3432	8.730 0.3437	8.730 0.3437	4.783 0.1883	4.808 0.1893		3/16
0.0027 0.006	0.0032 0.007	6.350 0.2500	6.337 0.2495	11.100 0.4370	11.125 0.4380	11.125 0.4380	6.388 0.2515	6.414 0.2525		1/4
0.0036 0.008	0.0041 0.009	6.350 0.2500	6.337 0.2495	11.100 0.4370	11.125 0.4380	11.125 0.4380	6.388 0.2515	6.414 0.2525		
0.0032 0.007	—	7.938 0.3125	7.925 0.3120	12.687 0.4995	12.713 0.5005	12.713 0.5005	7.976 0.3140	8.001 0.3150		5/16
0.0041 0.009	0.0050 0.011	7.938 0.3125	7.925 0.3120	12.687 0.4995	12.713 0.5005	12.713 0.5005	7.976 0.3140	8.001 0.3150		
0.0059 0.013	0.0073 0.016	7.938 0.3125	7.925 0.3120	14.275 0.5620	14.300 0.5630	14.300 0.5630	7.976 0.3140	8.001 0.3150		
0.0036 0.008	0.0041 0.009	9.525 0.3750	9.512 0.3745	14.275 0.5620	14.300 0.5630	14.300 0.5630	9.563 0.3765	9.589 0.3775		3/8
0.0041 0.009	0.0045 0.01	9.525 0.3750	9.512 0.3745	14.275 0.5620	14.300 0.5630	14.300 0.5630	9.563 0.3765	9.589 0.3775		
0.0054 0.012	0.0059 0.013	9.525 0.3750	9.512 0.3745	14.275 0.5620	14.300 0.5630	14.300 0.5630	9.563 0.3765	9.589 0.3775	IRA-3	
0.0077 0.017	—	9.525 0.3750	9.512 0.3745	15.862 0.6245	15.888 0.6255	15.888 0.6255	9.563 0.3765	9.589 0.3775	IRA-3	
0.0064 0.014	0.0073 0.016	11.113 0.4375	11.100 0.4370	15.862 0.6245	15.888 0.6255	15.888 0.6255	11.151 0.4390	11.176 0.4400		7/16
0.0086 0.019	—	11.113 0.4375	11.100 0.4370	17.450 0.6870	17.475 0.6880	17.475 0.6880	11.151 0.4390	11.176 0.4400		
0.0045 0.01	0.0054 0.012	12.700 0.5000	12.687 0.4995	17.450 0.6870	17.475 0.6880	17.475 0.6880	12.738 0.5015	12.764 0.5025		1/2
0.0050 0.011	0.0059 0.013	12.700 0.5000	12.687 0.4995	17.450 0.6870	17.475 0.6880	17.475 0.6880	12.738 0.5015	12.764 0.5025		
0.0068 0.015	0.0082 0.018	12.700 0.5000	12.687 0.4995	17.450 0.6870	17.475 0.6880	17.475 0.6880	12.738 0.5015	12.764 0.5025	IRA-5	
0.0104 0.023	—	12.700 0.5000	12.687 0.4995	17.450 0.6870	17.475 0.6880	17.475 0.6880	12.738 0.5015	12.764 0.5025		
0.0086 0.019	0.0104 0.023	12.700 0.5000	12.687 0.4995	19.037 0.7495	19.063 0.7505	19.063 0.7505	12.738 0.5015	12.764 0.5025		
0.0100 0.022	0.0118 0.026	12.700 0.5000	12.687 0.4995	19.037 0.7495	19.063 0.7505	19.063 0.7505	12.738 0.5015	12.764 0.5025		
0.0145 0.032	—	12.700 0.5000	12.687 0.4995	19.037 0.7495	19.063 0.7505	19.063 0.7505	12.738 0.5015	12.764 0.5025		
0.0073 0.016	0.0086 0.019	14.288 0.5625	14.275 0.5620	19.037 0.7495	19.063 0.7505	19.063 0.7505	14.326 0.5640	14.351 0.5650		9/16
0.0077 0.017	0.0091 0.02	14.288 0.5625	14.275 0.5620	19.037 0.7495	19.063 0.7505	19.063 0.7505	14.326 0.5640	14.351 0.5650	IR-68	

Continued on next page.



**CAGED BEARINGS –
OPEN ENDS, CLOSED ONE END – *continued***
INCH SERIES

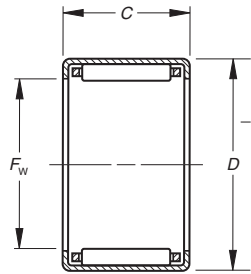

J, JH

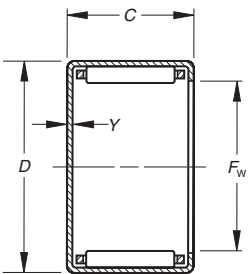

MJ-1, MJH-1

Mounting dimensions are based on the inner ring rotating and the outer ring being stationary relative to the load. The housing should be of high strength material.

See engineering section for discussion of shaft and housing design. See page C62 for mounting procedure.

Shaft Diameter	Dimensions mm/in. +0 +0.000 -0.3 -0.100				Bearing Designation		Load Ratings kN/lbf.		Limiting Speed		C _g	
	in.	F _w	D	C	Y			Dynamic	Static	Grease		Oil
	14.288 0.5625	19.050 0.7500	15.880 0.625	—		J-910	—	5.83 1310	7.21 1620	16000	25000	0.0205
	14.288 0.5625	20.638 0.8125	12.700 0.500	1.02 0.04		JH-98	MJH-981	8.01 1800	8.50 1910	12000	18000	N/A
5/8	15.875 0.6250	20.638 0.8125	12.700 0.500	1.02 0.04		J-108	MJ-1081	6.72 1510	9.12 2050	13000	21000	0.0227
	15.875 0.6250	20.638 0.8125	15.880 0.625	1.02 0.04		J-1010	MJ-10101	8.81 1980	12.94 2910	13000	21000	0.0247
	15.875 0.6250	20.638 0.8125	19.050 0.750	1.02 0.04		J-1012	MJ-10121	11.74 2640	18.86 4240	13000	21000	0.0272
	15.875 0.6250	22.212 0.8745	15.880 0.625	1.02 0.04		JH-1010	MJH-10101	11.57 2600	14.10 3170	14000	21000	0.024
	15.875 0.6250	22.212 0.8745	25.400 1.000	1.02 0.04		JH-1016	MJH-10161	19.79 4450	28.11 6320	14000	21000	0.0285
11/16	17.463 0.6875	22.212 0.8745	19.050 0.750	1.02 0.04		J-1112	MJ-11121	11.43 2570	18.73 4210	12000	19000	0.029
	17.463 0.6875	23.813 0.9375	15.880 0.625	1.02 0.04		JH-1110	MJH-11101	12.05 2710	15.21 3420	13000	19000	0.0255
	17.463 0.6875	23.813 0.9375	19.050 0.750	—		JH-1112	—	16.15 3630	22.20 4990	13000	19000	0.028
3/4	19.050 0.7500	25.400 1.0000	9.530 0.375	—		J-126	—	6.49 1460	7.03 1580	11000	18000	0.0218
	19.050 0.7500	25.400 1.0000	12.700 0.500	—		J-128	—	9.92 2230	12.19 2740	11000	18000	0.025
	19.050 0.7500	25.400 1.0000	15.880 0.625	1.02 0.04		J-1210	MJ-12101	12.50 2810	16.32 3670	11000	18000	0.0269
	19.050 0.7500	25.400 1.0000	19.050 0.750	1.02 0.04		J-1212	MJ-12121	15.52 3490	21.62 4860	11000	18000	0.0288
	19.050 0.7500	26.988 1.0625	19.050 0.750	1.02 0.04		JH-1212	MJH-12121	19.08 4290	23.58 5300	12000	18000	0.0285
13/16	20.638 0.8125	26.988 1.0625	22.230 0.875	—		J-1314	—	19.31 4340	29.31 6590	10000	16000	0.0321
	20.638 0.8125	28.575 1.1250	19.050 0.750	1.27 0.05		JH-1312	MJH-13121	18.77 4220	24.55 5520	11000	16000	0.0299
7/8	22.225 0.8750	28.575 1.1250	9.530 0.375	—		J-146	—	7.21 1620	8.41 1890	9700	15000	0.0243
	22.225 0.8750	28.575 1.1250	12.700 0.500	—		J-148	—	10.94 2460	14.50 3260	9700	15000	0.027
	22.225 0.8750	28.575 1.1250	19.050 0.750	1.02 0.04		J-1412	MJ-14121	17.88 4020	27.18 6110	9700	15000	0.0325
	22.225 0.8750	28.575 1.1250	25.400 1.000	1.02 0.04		J-1416	MJ-14161	23.66 5320	38.97 8760	9700	15000	0.0356
	22.225 0.8750	30.163 1.1875	19.050 0.750	1.27 0.05		JH-1412	MJH-14121	18.33 4120	24.55 5520	9800	15000	0.0309
	22.225 0.8750	30.163 1.1875	25.400 1.000	1.27 0.05		JH-1416	MJH-14161	25.40 5710	37.37 8400	9800	15000	0.0343

Wt. kg/lbs. Approx.		Bearing Mounting mm/in.				Inspection mm/in.			Matching Inner Ring	Shaft Diameter
Open Ends	Closed Ends	Max.	Min.	Min.	Max.	Ring Gage	Plug-GO	Plug-NO-Go		
		S		H						in.
0.0095 0.021	—	14.288 0.5625	14.275 0.5620	19.037 0.7495	19.063 0.7505	19.063 0.7505	14.326 0.5640	14.351 0.5650	IR-612	
0.0113 0.025	0.0136 0.03	14.288 0.5625	14.275 0.5620	20.625 0.8120	20.650 0.8130	20.650 0.8130	14.326 0.5640	14.351 0.5650	IR-68	
0.0086 0.019	0.0104 0.023	15.875 0.6250	15.862 0.6245	20.625 0.8120	20.650 0.8130	20.650 0.8130	15.913 0.6265	15.939 0.6275	IR-68-1	5/8
0.0104 0.023	0.0127 0.028	15.875 0.6250	15.862 0.6245	20.625 0.8120	20.650 0.8130	20.650 0.8130	15.913 0.6265	15.939 0.6275		
0.0127 0.028	0.0150 0.033	15.875 0.6250	15.862 0.6245	20.625 0.8120	20.650 0.8130	20.650 0.8130	15.913 0.6265	15.939 0.6275	IR-612-1	
0.0145 0.032	0.0168 0.037	15.875 0.6250	15.862 0.6245	22.212 0.8745	22.238 0.8755	22.238 0.8755	15.913 0.6265	15.939 0.6275		
0.0236 0.052	0.0281 0.062	15.875 0.6250	15.862 0.6245	22.212 0.8745	22.238 0.8755	22.238 0.8755	15.913 0.6265	15.939 0.6275		
0.0136 0.03	0.0163 0.036	17.463 0.6875	17.450 0.6870	22.212 0.8745	22.238 0.8755	22.238 0.8755	17.501 0.6890	17.526 0.6900		11/16
0.0159 0.035	0.0191 0.042	17.463 0.6875	17.450 0.6870	23.800 0.9370	23.825 0.9380	23.825 0.9380	17.501 0.6890	17.526 0.6900		
0.0191 0.042	—	17.463 0.6875	17.450 0.6870	23.800 0.9370	23.825 0.9380	23.825 0.9380	17.501 0.6890	17.526 0.6900		
0.0100 0.022	—	19.050 0.7500	19.037 0.7495	25.387 0.9995	25.413 1.0005	25.387 0.9995	19.063 0.7505	19.088 0.7515		3/4
0.0136 0.03	—	19.050 0.7500	19.037 0.7495	25.387 0.9995	25.413 1.0005	25.387 0.9995	19.063 0.7505	19.088 0.7515	IR-88	
0.0172 0.038	0.0204 0.045	19.050 0.7500	19.037 0.7495	25.387 0.9995	25.413 1.0005	25.387 0.9995	19.063 0.7505	19.088 0.7515		
0.0204 0.045	0.0245 0.054	19.050 0.7500	19.037 0.7495	25.387 0.9995	25.413 1.0005	25.387 0.9995	19.063 0.7505	19.088 0.7515	IR-812	
0.0263 0.058	0.0313 0.069	19.050 0.7500	19.037 0.7495	26.975 1.0620	27.000 1.0630	26.975 1.0620	19.063 0.7505	19.088 0.7515	IR-812	
0.0254 0.056	—	20.638 0.8125	20.625 0.8120	26.975 1.0620	27.000 1.0630	26.975 1.0620	20.650 0.8130	20.676 0.8140		13/16
0.0281 0.062	0.0336 0.074	20.638 0.8125	20.625 0.8120	28.562 1.1245	28.588 1.1255	28.562 1.1245	20.650 0.8130	20.676 0.8140		
0.0118 0.026	—	22.225 0.8750	22.212 0.8745	28.562 1.1245	28.588 1.1255	28.562 1.1245	22.238 0.8755	22.263 0.8765		7/8
0.0154 0.034	—	22.225 0.8750	22.212 0.8745	28.562 1.1245	28.588 1.1255	28.562 1.1245	22.238 0.8755	22.263 0.8765		
0.0236 0.052	0.0281 0.062	22.225 0.8750	22.212 0.8745	28.562 1.1245	28.588 1.1255	28.562 1.1245	22.238 0.8755	22.263 0.8765	IR-1012	
0.0313 0.069	0.0585 0.129	22.225 0.8750	22.212 0.8745	28.562 1.1245	28.588 1.1255	28.562 1.1245	22.238 0.8755	22.263 0.8765	IR-1016	
0.0299 0.066	0.0358 0.079	22.225 0.8750	22.212 0.8745	30.150 1.1870	30.175 1.1880	30.150 1.1870	22.238 0.8755	22.263 0.8765	IR-1012	
0.0404 0.089	0.0481 0.106	22.225 0.8750	22.212 0.8745	30.150 1.1870	30.175 1.1880	30.150 1.1870	22.238 0.8755	22.263 0.8765	IR-1016	

Continued on next page.



**CAGED BEARINGS –
OPEN ENDS, CLOSED ONE END – *continued***
INCH SERIES

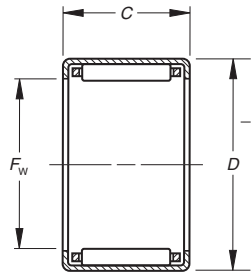

J,JH

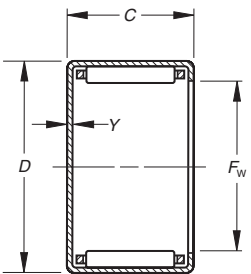

MJ-1, MJH-1

Mounting dimensions are based on the inner ring rotating and the outer ring being stationary relative to the load. The housing should be of high strength material.

See engineering section for discussion of shaft and housing design. See page C62 for mounting procedure.

Shaft Diameter	Dimensions mm/in. +0 +0.000 -0.3 -0.100				Bearing Designation		Load Ratings kN/lbf.		Limiting Speed		C _g	
	in.	F _w	D	C	Y		C	C ₀	Grease	Oil		
1	25.400	31.750	19.050	0.750	—	J-1612	—	18.15	28.82	8400	13000	0.035
	1.0000	1.2500	0.750					4080	6480			
	25.400	31.750	25.400	1.000	1.02	J-1616	MJ-16161	24.95	43.41	8400	13000	0.0387
	1.0000	1.2500	1.000	0.04	0.04			5610	9760			
	25.400	33.338	19.050	0.750	1.27	JH-1612	MJH-16121	20.68	29.58	8500	13000	0.0342
	1.0000	1.3125	0.750	0.05	0.05			4650	6650			
	25.400	33.338	25.400	1.000	1.27	JH-1616	MJH-16161	27.58	42.88	8500	13000	0.0375
	1.0000	1.3125	1.000	0.05	0.05			6200	9640			
1 1/8	28.575	34.925	12.700	0.500	1.02	J-188	MJ-1881	11.65	16.95	7400	11000	0.0323
	1.1250	1.3750	0.500	0.04	0.04			2620	3810			
	28.575	34.925	19.050	0.750	1.02	J-1812	MJ-18121	19.04	31.76	7400	11000	0.0377
	1.1250	1.3750	0.750	0.04	0.04			4280	7140			
	28.575	34.925	25.400	1.000	1.02	J-1816	MJ-18161	26.16	48.04	7400	11000	0.0418
	1.1250	1.3750	1.000	0.04	0.04			5880	10800			
	28.575	38.100	19.050	0.750	1.27	JH-1812	MJH-18121	23.35	31.32	7600	12000	0.0356
	1.1250	1.5000	0.750	0.05	0.05			5250	7040			
	28.575	38.100	25.400	1.000	1.27	JH-1816	MJH-18161	33.14	49.38	7600	12000	0.0398
	1.1250	1.5000	1.000	0.05	0.05			7450	11100			
	28.575	38.100	28.580	1.125	1.27	JH-1818	MJH-18181	36.30	55.16	7600	12000	0.041
	1.1250	1.5000	1.125	0.05	0.05			8160	12400			
1 1/4	31.750	38.100	19.050	0.750	1.02	J-2012	MJ-20121	19.84	34.70	6600	10000	0.0404
	1.2500	1.5000	0.750	0.04	0.04			4460	7800			
	31.750	38.100	25.400	1.000	1.02	J-2016	MJ-20161	28.82	56.49	6600	10000	0.0455
	1.2500	1.5000	1.000	0.04	0.04			6480	12700			
	31.750	41.275	19.050	0.750	—	JH-2012	—	24.11	33.94	6800	10000	0.038
	1.2500	1.6250	0.750	—	—			5420	7630			
	31.750	41.275	25.400	1.000	—	JH-2016	—	33.94	52.93	6800	10000	0.0424
	1.2500	1.6250	1.000	—	—			7630	11900			
	31.750	41.275	31.750	1.250	—	JH-2020	—	43.37	72.51	6800	10000	0.0459
	1.2500	1.6250	1.250	—	—			9750	16300			
1 3/8	34.925	41.275	12.700	0.500	1.02	J-228	MJ-2281	13.97	22.91	6000	9200	0.038
	1.3750	1.6250	0.500	0.04	0.04			3140	5150			
	34.925	41.275	19.050	0.750	—	J-2212	—	22.82	42.97	6000	9200	0.0444
	1.3750	1.6250	0.750	—	—			5130	9660			
	34.925	44.450	19.050	0.750	1.27	JH-2212	MJH-22121	26.24	38.43	6100	9400	0.0407
	1.3750	1.7500	0.750	0.05	0.05			5900	8640			
	34.925	44.450	25.400	1.000	1.27	JH-2216	MJH-22161	36.52	58.72	6100	9400	0.0452
	1.3750	1.7500	1.000	0.05	0.05			8210	13200			
1 1/2	38.100	47.625	19.050	0.750	1.27	J-2412	MJ-24121	29.89	47.15	5600	8600	0.0445
	1.5000	1.8750	0.750	0.05	0.05			6720	10600			
	38.100	47.625	25.400	1.000	1.27	J-2416	MJ-24161	39.32	66.72	5600	8600	0.0486
	1.5000	1.8750	1.000	0.05	0.05			8840	15000			
	38.100	47.625	31.750	1.250	—	J-2420	—	49.38	89.85	5600	8600	0.0523
	1.5000	1.8750	1.250	—	—			11100	20200			
1 5/8	41.275	50.800	15.880	—	—	J-2610	—	26.11	40.97	5100	7900	0.0446
	1.6250	2.0000	0.625	—	—			5870	9210			

Wt. kg/lbs. Approx.		Bearing Mounting mm/in.				Inspection mm/in.			Matching Inner Ring	Shaft Diameter
Open Ends	Closed Ends	Max.	Min.	Min.	Max.	Ring Gage	Plug-GO	Plug-NO-Go		
		S		H						in.
0.0263 0.058	—	25.400 1.0000	25.387 0.9995	31.737 1.2495	31.763 1.2505	31.737 1.2495	25.413 1.0005	25.438 1.0015	IR-1212	1
0.0349 0.077	0.0417 0.092	25.400 1.0000	25.387 0.9995	31.737 1.2495	31.763 1.2505	31.737 1.2495	25.413 1.0005	25.438 1.0015	IR-1216	
0.0336 0.074	0.0399 0.088	25.400 1.0000	25.387 0.9995	33.325 1.3120	33.350 1.3130	33.325 1.3120	25.413 1.0005	25.438 1.0015	IR-1212	
0.0449 0.099	0.0540 0.119	25.400 1.0000	25.387 0.9995	33.325 1.3120	33.350 1.3130	33.325 1.3120	25.413 1.0005	25.438 1.0015	IR-1216	
0.0195 0.043	0.0227 0.05	28.575 1.1250	28.562 1.1245	34.912 1.3745	34.938 1.3755	34.912 1.3745	28.588 1.1255	28.613 1.1265		1 1/8
0.0290 0.064	0.0345 0.076	28.575 1.1250	28.562 1.1245	34.912 1.3745	34.938 1.3755	34.912 1.3745	28.588 1.1255	28.613 1.1265		
0.0390 0.086	0.0467 0.103	28.575 1.1250	28.562 1.1245	34.912 1.3745	34.938 1.3755	34.912 1.3745	28.588 1.1255	28.613 1.1265	IR-1416	
0.0458 0.101	0.0549 0.121	28.575 1.1250	28.562 1.1245	38.087 1.4995	38.113 1.5005	38.087 1.4995	28.588 1.1255	28.613 1.1265		
0.0612 0.135	0.0735 0.162	28.575 1.1250	28.562 1.1245	38.087 1.4995	38.113 1.5005	38.087 1.4995	28.588 1.1255	28.613 1.1265	IR-1416	
0.0689 0.152	0.0821 0.181	28.575 1.1250	28.562 1.1245	38.087 1.4995	38.113 1.5005	38.087 1.4995	28.588 1.1255	28.613 1.1265		
0.0363 0.08	0.0431 0.095	31.750 1.2500	31.737 1.2495	38.087 1.4995	38.113 1.5005	38.087 1.4995	31.763 1.2505	31.788 1.2515	IR-1612	1 1/4
0.0426 0.094	0.0513 0.113	31.750 1.2500	31.737 1.2495	38.087 1.4995	38.113 1.5005	38.087 1.4995	31.763 1.2505	31.788 1.2515	IR-1616	
0.0503 0.111	—	31.750 1.2500	31.737 1.2495	41.262 1.6245	41.288 1.6255	41.262 1.6245	31.763 1.2505	31.788 1.2515	IR-1612	
0.0671 0.148	—	31.750 1.2500	31.737 1.2495	41.262 1.6245	41.288 1.6255	41.262 1.6245	31.763 1.2505	31.788 1.2515	IR-1616	
0.0839 0.185	—	31.750 1.2500	31.737 1.2495	41.262 1.6245	41.288 1.6255	41.262 1.6245	31.763 1.2505	31.788 1.2515		
0.0236 0.052	0.0281 0.062	34.925 1.3750	34.912 1.3745	41.262 1.6245	41.288 1.6255	41.262 1.6245	34.938 1.3755	34.966 1.3766		1 3/8
0.0349 0.077	—	34.925 1.3750	34.912 1.3745	41.262 1.6245	41.288 1.6255	41.262 1.6245	34.938 1.3755	34.966 1.3766	IR-1812	
0.0549 0.121	0.0653 0.144	34.925 1.3750	34.912 1.3745	44.437 1.7495	44.463 1.7505	44.437 1.7495	34.938 1.3755	34.966 1.3766	IR-1812	
0.0730 0.161	0.0871 0.192	34.925 1.3750	34.912 1.3745	44.437 1.7495	44.463 1.7505	44.437 1.7495	34.938 1.3755	34.966 1.3766	IR-1816	
0.0594 0.131	0.0943 0.208	38.100 1.5000	38.087 1.4995	47.612 1.8745	47.638 1.8755	47.612 1.8745	38.113 1.5005	38.143 1.5017		1 1/2
0.0789 0.174	0.0943 0.208	38.100 1.5000	38.087 1.4995	47.612 1.8745	47.638 1.8755	47.612 1.8745	38.113 1.5005	38.143 1.5017	IR-1916	
0.0989 0.218	—	38.100 1.5000	38.087 1.4995	47.612 1.8745	47.638 1.8755	47.612 1.8745	38.113 1.5005	38.143 1.5017	IR-1920	
0.0531 0.117	—	41.275 1.6250	41.262 1.6245	50.787 1.9995	50.813 2.0005	50.787 1.9995	41.288 1.6255	41.318 1.6267		1 5/8

Continued on next page.



**CAGED BEARINGS –
OPEN ENDS, CLOSED ONE END – *continued***
INCH SERIES

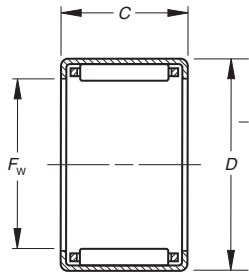

J, JH

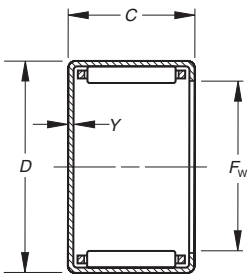

MJ-1, MJH-1

Shaft Diameter	Dimensions mm/in. +0 +0.000 -0.3 -0.100				Bearing Designation		Load Ratings kN/lbf.		Limiting Speed		C _g
	in.	F _w	D	C	Y	C	C ₀	Grease RPM	Oil RPM		
	41.275 1.6250	50.800 2.0000	25.400 1.000	1.27 0.05	J-2616	M-26161	39.28 8830	68.95 15500	5100	7900	0.0508
1 3/4	44.450 1.7500	53.975 2.1250	19.050 0.750	1.27 0.05	J-2812	MJ-28121	29.58 6650	49.38 11100	4700	7300	0.0483
	44.450 1.7500	53.975 2.1250	25.400 1.000	1.27 0.05	J-2816	MJ-28161	40.08 9010	72.95 16400	4700	7300	0.0532
	44.450 1.7500	53.975 2.1250	38.100 1.500	1.27 0.05	J-2824	MJ-28241	59.61 13400	121.88 27400	4700	7300	0.0605
1 7/8	47.625 1.8750	57.150 2.2500	25.400 1.000	1.27 0.05	J-3016	MJ-30161	41.10 9240	76.06 17100	4400	6800	0.0553
2	50.800 2.0000	60.325 2.3750	25.400 1.000	1.27 0.05	J-3216	MJ-32161	42.39 9530	81.40 18300	4100	6300	0.0579
2 1/4	57.150 2.2500	66.675 2.6250	19.050 0.750	—	J-3612	—	35.41 7960	65.83 14800	3600	5600	0.0577
	57.150 2.2500	66.675 2.6250	25.400 1.000	—	J-3616	—	46.26 10400	92.52 20800	3600	5600	0.0628
2 3/4	69.850 2.7500	79.375 3.1250	19.050 0.750	—	J-4412	—	36.25 8150	72.95 16400	2900	4500	0.0649

Mounting dimensions are based on the inner ring rotating and the outer ring being stationary relative to the load. The housing should be of high strength material.

See engineering section for discussion of shaft and housing design. See page C62 for mounting procedure.

Wt. kg/lbs. Approx.		Bearing Mounting mm/in.				Inspection mm/in.			Matching Inner Ring	Shaft Diameter
Open Ends	Closed Ends	Max.	Min.	Min.	Max.	Ring Gage	Plug-GO	Plug-NO-Go		
		S		H						in.
0.0848 0.187	0.1012 0.223	41.275 1.6250	41.262 1.6245	50.787 1.9995	50.813 2.0005	50.787 1.9995	41.288 1.6255	41.318 1.6267		
0.0680 0.15	0.0812 0.179	44.450 1.7500	44.437 1.7495	53.962 2.1245	53.988 2.1255	53.962 2.1245	44.463 1.7505	44.496 1.7518		1 3/4
0.0907 0.2	0.1084 0.239	44.450 1.7500	44.437 1.7495	53.962 2.1245	53.988 2.1255	53.962 2.1245	44.463 1.7505	44.496 1.7518	IR-2316	
0.1361 0.3	0.1624 0.358	44.450 1.7500	44.437 1.7495	53.962 2.1245	53.988 2.1255	53.962 2.1245	44.463 1.7505	44.496 1.7518	IR-2324	
0.0966 0.213	0.1152 0.254	47.625 1.8750	47.612 1.8745	57.137 2.2495	57.163 2.2505	57.137 2.2495	47.638 1.8755	47.671 1.8768		1 7/8
0.1025 0.226	0.1365 0.301	50.800 2.0000	50.785 1.9994	60.312 2.3745	60.338 2.3755	60.312 2.3745	50.815 2.0006	50.848 2.0019		2
0.0857 0.189	—	57.150 2.2500	57.135 2.2494	66.662 2.6245	66.688 2.6255	66.662 2.6245	57.165 2.2506	57.203 2.2521		2 1/4
0.1143 0.252	—	57.150 2.2500	57.135 2.2494	66.662 2.6245	66.688 2.6255	66.662 2.6245	57.165 2.2506	57.203 2.2521		
0.1030 0.227	—	69.850 2.7500	69.835 2.7494	79.362 3.1245	79.388 3.1255	79.362 3.1245	69.875 2.7510	69.914 2.7525	IR-4016	2 3/4

C





SEALED DRAWN CUP BEARINGS

INCH SERIES

- Check for availability. Not all bearings are in production.
- Prepacked with general purpose ball and roller bearing grease unless otherwise specified.
- Bearing operating temperature limited between -25° F and +225° F.
- Consult your Timken representative for operating temperatures outside the above range or if seals exposed to unusual fluids.
- Limiting speed based on shaft contact speed of 2000 RPM.
- Reduce the listed limiting speed by one-half for outer ring rotation.

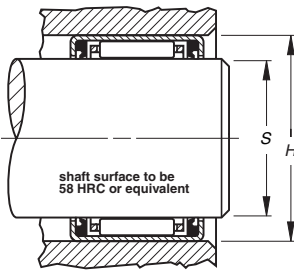
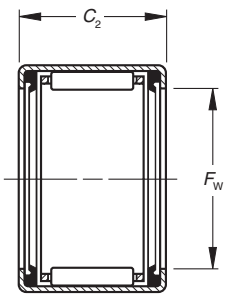
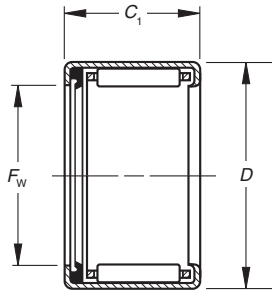

Drawn cup bearings of nominal inch dimensions, with one seal and one end closed, may be made available upon request.

Mounting dimensions are based on the inner ring rotating and the outer ring being stationary relative to the load. The housing should be of high strength material. See engineering section for discussion of shaft and housing design. See page C62 for mounting procedure.

Shaft Diameter	Dimensions mm/in.			Bearings With One Seal mm/in.		Bearings With Two Seals mm/in.		
	F_w	D	C_1	Bearing Designation Open End	Wt. Approx. kg/lbs.	C_2	Bearing Designation	Wt. Approx. kg/lbs.
in.	F_w	D	C_1			C_2		
$+0 +0.000$ $-0.3 -0.100$						$+0 +0.000$ $-0.3 -0.010$		
5/16	7.938 0.3125	12.700 0.5000	9.53 0.375	JT-56	0.004 0.008	11.13 0.438	JTT-57	0.004 0.009
	7.938 0.3125	12.700 0.5000	—	—	—	14.27 0.562	JTT-59	0.005 0.012
3/8	9.525 0.3750	14.288 0.5625	9.53 0.375	JT-66	0.004 0.009	11.13 0.438	JTT-67	0.005 0.011
	9.525 0.3750	14.288 0.5625	14.27 0.562	JT-69	0.006 0.014	—	—	—
1/2	12.700 0.5000	17.463 0.6875	9.53 0.375	JT-86	0.005 0.012	11.13 0.438	JTT-87	0.006 0.013
	12.700 0.5000	17.463 0.6875	14.27 0.562	JT-89	0.008 0.017	15.88 0.625	JTT-810	0.009 0.019
	12.700 0.5000	17.463 0.6875	—	—	—	22.23 0.875	JTT-814	0.012 0.027
9/16	14.288 0.5625	19.050 0.7500	14.27 0.562	JT-99	0.009 0.019	15.88 0.625	JTT-910	0.010 0.021
	14.288 0.5625	19.050 0.7500	—	—	—	19.05 0.75	JTT-912	0.011 0.025
5/8	15.875 0.6250	20.638 0.8125	14.27 0.562	JT-109	0.010 0.021	15.88 0.625	JTT-1010	0.010 0.023
	15.875 0.6250	20.638 0.8125	—	—	—	19.05 0.75	JTT-1012	0.013 0.028
	15.875 0.6250	20.638 0.8125	—	—	—	22.23 0.875	JTT-1014	0.015 0.032
11/16	17.463 0.6875	22.225 0.8750	—	—	—	22.23 0.875	JTT-1114	0.016 0.035
3/4	19.050 0.7500	25.400 1.0000	14.27 0.562	JT-129	0.015 0.034	15.88 0.625	JTT-1210	0.017 0.038
	19.050 0.7500	25.400 1.0000	17.48 0.688	JT-1211	0.019 0.041	—	—	—
	19.050 0.7500	25.400 1.0000	20.62 0.812	JT-1213	0.022 0.049	22.23 0.875	JTT-1214	0.024 0.053
7/4	22.225 0.8750	28.575 1.1250	14.27 0.562	JT-149	0.018 0.039	15.88 0.625	JTT-1410	0.020 0.043
	22.225 0.8750	28.575 1.1250	26.97 1.062	JT-1417	0.033 0.073	—	—	—
1	25.400 1.0000	31.750 1.2500	20.62 0.812	JT-1613	0.029 0.063	22.23 0.875	JTT-1614	0.031 0.068
1 1/8	28.575 1.1250	34.925 1.3750	20.62 0.812	JT-1813	0.032 0.070	22.23 0.875	JTT-1814	0.034 0.075
1 1/4	31.750 1.2500	38.100 1.5000	20.62 0.812	JT-2013	0.035 0.077	—	—	—
	31.750 1.2500	38.100 1.500	—	—	—	28.58 1.125	JTT-2018	0.048 0.106
1 1/2	38.100 1.500	47.625 1.875	33.32 1.312	JT-2421	0.104 0.229	—	—	—

Load Ratings KN/lbf.		Limiting Speed Approx.		Bearing Mounting mm/in.				Shaft Diameter
Dynamic	Static			Max.	Min.	Min.	Max.	
C	C₀	RPM	C_g	S		H		in.
2.40 540	2.00 450	18000	0.0117	7.938 0.3125	7.925 0.3120	12.687 0.4995	12.713 0.5005	5/16
4.05 910	3.91 880	18000	0.0138	7.938 0.3125	7.925 0.3120	12.687 0.4995	12.713 0.5005	
2.74 615	2.49 560	18000	0.0133	9.525 0.3750	9.512 0.3745	14.275 0.5620	14.300 0.5630	3/8
5.20 1 170	5.74 1 290	18000	0.0163	9.525 0.3750	9.512 0.3745	14.275 0.5620	14.300 0.5630	
3.47 780	3.65 820	15000	0.0164	12.700 0.5000	12.687 0.4995	17.450 0.6870	17.475 0.6880	1/2
6.32 1 420	7.92 1 780	15000	0.0199	12.700 0.5000	12.687 0.4995	17.450 0.6870	17.475 0.6880	
10.2 2 300	14.7 3 310	15000	0.0232	12.700 0.5000	12.687 0.4995	17.450 0.6870	17.475 0.6880	
6.23 1 400	8.01 1 800	14000	0.0210	14.288 0.5625	14.275 0.5620	19.037 0.7495	19.063 0.7505	9/16
8.18 1 840	11.4 2 560	14000	0.0229	14.288 0.5625	14.275 0.5620	19.037 0.7495	19.063 0.7505	
6.72 1 510	9.12 2 050	12000	0.0227	15.875 0.6250	15.862 0.6245	20.625 0.8120	20.650 0.8130	5/8
8.81 1 980	12.9 2 910	12000	0.0247	15.875 0.6250	15.862 0.6245	20.625 0.8120	20.650 0.8130	
11.7 2 640	18.9 4 240	12000	0.0272	15.875 0.6250	15.862 0.6245	20.625 0.8120	20.650 0.8130	
12.5 2 800	20.9 4 700	11000	0.0290	17.463 0.6875	17.450 0.6870	22.212 0.8745	22.238 0.8755	11/16
9.92 2 230	12.2 2 740	10000	0.0250	19.050 0.7500	19.037 0.7495	25.387 0.9995	25.413 1.0005	3/4
12.5 2 810	16.3 3 670	10000	0.0269	19.050 0.7500	19.037 0.7495	25.387 0.9995	25.413 1.0005	
15.5 3 490	21.6 4 860	10000	0.0288	19.050 0.7500	19.037 0.7495	25.387 0.9995	25.413 1.0005	
10.9 2 460	14.5 3 260	8700	0.0278	22.225 0.8750	22.212 0.8745	28.562 1.1245	28.588 1.1255	7/8
23.7 5 320	39.0 8 760	8700	0.0356	22.225 0.8750	22.212 0.8745	28.562 1.1245	28.588 1.1255	
18.1 4 080	28.8 6 480	7600	0.035	25.400 1.0000	25.387 0.9995	31.737 1.2495	31.763 1.2505	1
19.0 4 280	31.8 7 140	6800	0.0377	28.575 1.125	28.562 1.1245	34.912 1.3745	34.938 1.3755	1 1/8
19.8 4 460	34.7 7 800	6100	0.0404	31.750 1.2500	31.737 1.2495	38.087 1.4995	38.113 1.5005	1 1/4
28.8 6 480	56.5 12 700	6100	0.0455	31.750 1.2500	31.737 1.2495	38.087 1.4995	38.113 1.5005	
49.4 11 100	89.9 20 200	5100	0.0523	38.100 1.5000	38.087 1.4995	47.612 1.8745	47.638 1.8755	1 1/2





INNER RINGS FOR INCH SERIES DRAWN CUP BEARINGS

- Check for availability.
- Ideal choice where shaft not practical to use as inner raceway.
- Provided in inch (IR, IRA) nominal dimensions for use with inch series drawn cup bearings.
- Designed to meet established inch tolerances.
- Designed to be wider than matching drawn cup bearing.
- Maximum shaft fillet radius (r_{as-max}) cannot exceed inner ring bore chamfer (r_{s-min}) as shown.
- Optional centralized lubrication groove (bore) or thru-hole available – specify when ordering.
- Designed to be axially clamped against shoulder for loose transition fit on shaft.
- After mounting, for tight transition fit (keeping inner ring from rotating relative to shaft), inner ring O.D. must not exceed raceway diameter on matching bearing.
- See tables for required bearing dimensions raceway diameter.
- After mounting, if O.D. of inner ring exceeds required raceway diameter for matching bearing, ring should be ground to proper diameter while mounted on shaft.
- Unmarked end of inner ring to be assembled against shaft shoulder to assure clearing maximum allowable shaft fillet ($r_{as max}$) as indicated in tables shown.

Shaft Diameter	Dimensions mm/in.							Inner Ring Designation	Transition Fit				Wt. mm/lbs. Approx.
	Min.	Max.	Max.	Min.	Max.	Min.	Min.		Loose Max.	Transition Fit Min.	Tight Max.	Tight Min.	
in.	d		F		B		$r_{s min}$		S				
3/16	4.813	4.826	9.525	9.512	13.614	13.360	0.64	IRA-3	4.818	4.806	4.829	4.816	0.053
	0.1895	0.1900	0.3750	0.3745	0.5360	0.5260	0.025		0.1897	0.1892	0.1901	0.1896	
1/4	6.337	6.350	11.113	11.100	13.614	13.360	0.64	IRA-4	6.342	6.330	6.353	6.340	0.062
	0.2495	0.2500	0.4375	0.4370	0.5360	0.5260	0.025		0.2497	0.2492	0.2501	0.2496	
5/16	7.925	7.938	12.700	12.687	13.614	13.360	0.64	IRA-5	7.930	7.917	7.940	7.927	0.076
	0.3120	0.3125	0.5000	0.4995	0.5360	0.5260	0.025		0.3122	0.3117	0.3126	0.3121	
3/8	9.512	9.525	14.288	14.275	13.081	12.827	0.64	IR-68	9.517	9.505	9.528	9.515	0.085
	0.3745	0.3750	0.5625	0.5620	0.5150	0.5050	0.025		0.3747	0.3742	0.3751	0.3746	0.019
	9.512	9.525	14.288	14.275	19.431	19.177	0.64	IR-612	9.517	9.505	9.528	9.515	0.125
	0.3745	0.3750	0.5625	0.5620	0.7650	0.7550	0.025		0.3747	0.3742	0.3751	0.3746	0.028
3/8	9.512	9.525	14.288	14.275	19.964	19.710	0.64	IRA-6	9.517	9.505	9.528	9.515	0.129
	0.3745	0.3750	0.5625	0.5620	0.7860	0.7760	0.025		0.3747	0.3742	0.3751	0.3746	0.029
	9.512	9.525	15.875	15.862	13.081	12.827	0.64	IR-68-1	9.517	9.505	9.528	9.515	0.120
	0.3745	0.3750	0.6250	0.6245	0.5150	0.5050	0.025		0.3747	0.3742	0.3751	0.3746	0.027
3/8	9.512	9.525	15.875	15.862	19.431	19.177	0.64	IR-612-1	9.517	9.505	9.528	9.515	0.178
	0.3745	0.3750	0.6250	0.6245	0.7650	0.7550	0.025		0.3747	0.3742	0.3751	0.3746	0.040
	11.100	11.113	15.875	15.862	19.964	19.710	0.64	IRA-7	11.105	11.092	11.115	11.102	0.147
	0.4370	0.4375	0.6250	0.6245	0.7860	0.7760	0.025		0.4372	0.4367	0.4376	0.4371	0.033
1/2	12.687	12.700	19.050	19.037	13.081	12.827	1.02	IR-88	12.692	12.680	12.703	12.690	0.147
	0.4995	0.5000	0.7500	0.7495	0.5150	0.5050	0.040		0.4997	0.4992	0.5001	0.4996	0.033
	12.687	12.700	19.050	19.037	19.431	19.177	1.02	IR-812	12.692	12.680	12.703	12.690	0.222
	0.4995	0.5000	0.7500	0.7495	0.7650	0.7550	0.040		0.4997	0.4992	0.5001	0.4996	0.050
1/2	12.687	12.700	19.050	19.037	19.964	19.710	1.02	IRA-8	12.692	12.680	12.703	12.690	0.227
	0.4995	0.5000	0.7500	0.7495	0.7860	0.7760	0.040		0.4997	0.4992	0.5001	0.4996	0.051
	15.862	15.875	22.225	22.212	19.431	19.177	1.02	IR-1012	15.867	15.855	15.878	15.865	0.267
	0.6245	0.6250	0.8750	0.8745	0.7650	0.7550	0.040		0.6247	0.6242	0.6251	0.6246	0.060
1/2	15.862	15.875	22.225	22.212	19.964	19.710	1.02	IRA-10	15.867	15.855	15.878	15.865	0.276
	0.6245	0.6250	0.8750	0.8745	0.7860	0.7760	0.040		0.6247	0.6242	0.6251	0.6246	0.062
	15.862	15.875	22.225	22.212	25.781	25.527	1.02	IR-1016	15.867	15.855	15.878	15.865	0.356
	0.6245	0.6250	0.8750	0.8745	1.0150	1.0050	0.040		0.6247	0.6242	0.6251	0.6246	0.080
3/4	19.037	19.050	25.400	25.387	13.081	12.827	1.02	IR-128	19.042	19.030	19.053	19.040	0.209
	0.7495	0.7500	1.0000	0.9995	0.5150	0.5050	0.040		0.7497	0.7492	0.7501	0.7496	0.047
	19.037	19.050	25.400	25.387	19.431	19.177	1.02	IR-1212	19.042	19.030	19.053	19.040	0.311
	0.7495	0.7500	1.0000	0.9995	0.7650	0.7550	0.040		0.7497	0.7492	0.7501	0.7496	0.070
3/4	19.037	19.050	25.400	25.387	25.781	25.527	1.02	IR-1216	19.042	19.030	19.053	19.040	0.414
	0.7495	0.7500	1.0000	0.9995	1.0150	1.0050	0.040		0.7497	0.7492	0.7501	0.7496	0.093
	19.037	19.050	25.400	25.387	26.314	26.060	1.02	IRA-12	19.042	19.030	19.053	19.040	0.423
	0.7495	0.7500	1.0000	0.9995	1.0360	1.0260	0.040		0.7497	0.7492	0.7501	0.7496	0.095
3/4	19.037	19.050	25.400	25.387	32.131	31.877	1.02	IR-1220	19.042	19.030	19.053	19.040	0.516
	0.7495	0.7500	1.0000	0.9995	1.2650	1.2550	0.040		0.7497	0.7492	0.7501	0.7496	0.116

Bore and O.D. tolerance limits correspond to the single mean diameter (the arithmetical mean of the largest and smallest diameters in a single radial plane).
 * $r_{as max}$ is equal to minimum inner ring bore chamfer ($r_{s min}$) at unmarked end.

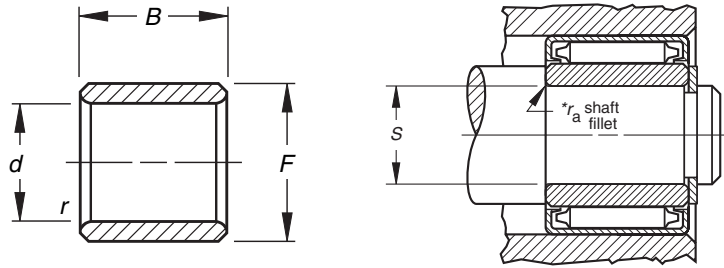

Shaft Diameter	Dimensions mm/in.							Inner Ring Designation	Transition Fit				Wt. mm/lbs. Approx.
	Min.	Max.	Max.	Min.	Max.	Min.	Min.		Loose Max.	Min.	Max.	Tight Min.	
in.	d		F		B		r _s min.		S				
	19.037 0.7495	19.050 0.7500	25.400 1.0000	25.387 0.9995	38.481 1.5150	38.227 1.5050	1.02 0.040	IR-1224	19.042 0.7497	19.030 0.7492	19.053 0.7501	19.040 0.7496	0.618 0.139
13/16	20.625 0.8120	20.638 0.8125	25.400 1.0000	25.387 0.9995	19.431 0.7650	19.177 0.7550	1.02 0.040	IR-1312	20.630 0.8122	20.617 0.8117	20.640 0.8126	20.627 0.8121	0.240 0.054
	20.625 0.8120	20.638 0.8125	25.400 1.0000	25.387 0.9995	25.781 1.0150	25.527 1.0050	1.02 0.040	IR-1316	20.630 0.8122	20.617 0.8117	20.640 0.8126	20.627 0.8121	0.320 0.072
7/8	22.212 0.8745	22.225 0.8750	28.575 1.1250	28.562 1.1245	25.781 1.0150	25.527 1.0050	1.02 0.040	IR-1416	22.217 0.8747	22.205 0.8742	22.228 0.8751	22.215 0.8746	0.494 0.111
	22.212 0.8745	22.225 0.8750	28.575 1.1250	28.562 1.1245	26.314 1.0360	26.060 1.0260	1.02 0.040	IRA-14	22.217 0.8747	22.205 0.8742	22.228 0.8751	22.215 0.8746	0.480 0.108
15/16	23.800 0.9370	23.813 0.9375	28.575 1.1250	28.562 1.1245	25.781 1.0150	25.527 1.0050	1.02 0.040	IR-1516	23.805 0.9372	23.792 0.9367	23.815 0.9376	23.802 0.9371	0.365 0.082
1	25.387 0.9995	25.400 1.0000	31.750 1.2500	31.737 1.2495	19.431 0.7650	19.177 0.7550	1.02 0.040	IR-1612	25.392 0.9997	25.380 0.9992	25.403 1.0001	25.390 0.9996	0.400 0.090
	25.387 0.9995	25.400 1.0000	31.750 1.2500	31.737 1.2495	25.781 1.0150	25.527 1.0050	1.02 0.040	IR-1616	25.392 0.9997	25.380 0.9992	25.403 1.0001	25.390 0.9996	0.556 0.125
	25.387 0.9995	25.400 1.0000	31.750 1.2500	31.737 1.2495	26.314 1.0360	26.060 1.0260	1.02 0.040	IRA-16	25.392 0.9997	25.380 0.9992	25.403 1.0001	25.390 0.9996	0.543 0.122
1 1/8	28.562 1.1245	28.575 1.1250	34.925 1.3750	34.912 1.3745	19.431 0.7650	19.177 0.7550	1.02 0.040	IR-1812	28.567 1.1247	28.555 1.1242	28.578 1.1251	28.565 1.1246	0.445 0.100
	28.562 1.1245	28.575 1.1250	34.925 1.3750	34.912 1.3745	25.781 1.0150	25.527 1.0050	1.02 0.040	IR-1816	28.567 1.1247	28.555 1.1242	28.578 1.1251	28.565 1.1246	0.592 0.133
	28.562 1.1245	28.575 1.1250	34.925 1.3750	34.912 1.3745	32.131 1.2650	31.877 1.2550	1.02 0.040	IR-1820	28.567 1.1247	28.555 1.1242	28.578 1.1251	28.565 1.1246	0.738 0.166
1 3/16	30.150 1.1870	30.163 1.1875	38.100 1.5000	38.087 1.4995	25.781 1.0150	25.527 1.0050	1.02 0.040	IR-1916	30.155 1.1872	30.142 1.1867	30.165 1.1876	30.152 1.1871	0.827 0.186
	30.150 1.1870	30.163 1.1875	38.100 1.5000	38.087 1.4995	32.131 1.2650	31.877 1.2550	1.02 0.040	IR-1920	30.155 1.1872	30.142 1.1867	30.165 1.1876	30.152 1.1871	0.992 0.223
1 1/4	31.737 1.2495	31.750 1.2500	38.100 1.5000	38.087 1.4995	25.781 1.0150	25.527 1.0050	1.52 0.060	IR-2016	31.742 1.2497	31.730 1.2492	31.753 1.2501	31.740 1.2496	0.676 0.152
	31.737 1.2495	31.750 1.2500	38.100 1.5000	38.087 1.4995	32.131 1.2650	31.877 1.2550	1.52 0.060	IR-2020	31.742 1.2497	31.730 1.2492	31.753 1.2501	31.740 1.2496	0.845 0.190
	31.737 1.2495	31.750 1.2500	38.100 1.5000	38.087 1.4995	32.664 1.2860	32.410 1.2760	1.52 0.060	IRA-20	31.742 1.2497	31.730 1.2492	31.753 1.2501	31.740 1.2496	0.845 0.190
1 3/8	34.912 1.3745	34.925 1.3750	41.275 1.6250	41.262 1.6245	32.131 1.2650	31.877 1.2550	1.52 0.060	IR-2220	34.917 1.3747	34.905 1.3742	34.928 1.3751	34.915 1.3746	0.925 0.208
1 7/16	36.500 1.4370	36.513 1.4375	44.450 1.7500	44.437 1.7495	25.781 1.0150	25.527 1.0050	1.52 0.060	IR-2316	36.505 1.4372	36.492 1.4367	36.515 1.4376	36.502 1.4371	0.979 0.220

Continued on next page.



**INNER RINGS FOR INCH SERIES
DRAWN CUP BEARINGS**

- Check for availability.
- Ideal choice where shaft not practical to use as inner raceway.
- Provided in inch (IR, IRA) nominal dimensions for use with inch series drawn cup bearings.
- Designed to meet established inch tolerances.
- Designed to be wider than matching drawn cup bearing.
- Maximum shaft fillet radius (r_{as-max}) cannot exceed inner ring bore chamfer (r_{s-min}) as shown.
- Optional centralized lubrication groove (bore) or thru-hole available – specify when ordering.
- Designed to be axially clamped against shoulder for loose transition fit on shaft.
- After mounting, for tight transition fit (keeping inner ring from rotating relative to shaft), inner ring O.D. must not exceed raceway diameter on matching bearing.
- See tables for required bearing dimensions raceway diameter.
- After mounting, if O.D. of inner ring exceeds required raceway diameter for matching bearing, ring should be ground to proper diameter while mounted on shaft.
- Unmarked end of inner ring to be assembled against shaft shoulder to assure clearing maximum allowable shaft fillet ($r_{as max}$) as indicated in tables shown.

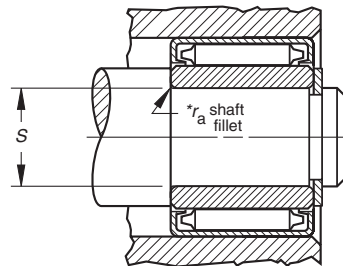
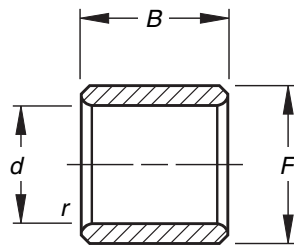

Shaft Diameter	Dimensions mm/in.							Inner Ring Designation	Transition Fit				Wt. mm/lbs. Approx.
	Min.	Max.	Max.	Min.	Max.	Min.	Min.		Loose Max.	Min.	Tight Max.	Min.	
in.	d		F		B		$r_{s min.}$	S					
	36.500 1.4370	36.513 1.4375	44.450 1.7500	44.437 1.7495	38.481 1.5150	38.227 1.5050	1.52 0.060	IR-2324	36.505 1.4372	36.492 1.4367	36.515 1.4376	36.502 1.4371	1.472 0.331
1 1/2	38.087 1.4995	38.100 1.5000	44.450 1.7500	44.437 1.7495	25.781 1.0150	25.527 1.0050	1.52 0.060	IR-2416	38.092 1.4997	38.080 1.4992	38.103 1.5001	38.090 1.4996	0.770 0.173
	38.087 1.4995	38.100 1.5000	44.450 1.7500	44.437 1.7495	38.481 1.5150	38.227 1.5050	1.52 0.060	IR-2424	38.092 1.4997	38.080 1.4992	38.103 1.5001	38.090 1.4996	1.201 0.270
1 11/16	42.850 1.6870	42.863 1.6875	52.388 2.0625	52.375 2.0620	38.481 1.5150	38.227 1.5050	1.52 0.060	IR-2724	42.855 1.6872	42.842 1.6867	42.865 1.6876	42.852 1.6871	2.082 0.468
1 3/4	44.437 1.7495	44.450 1.7500	52.388 2.0625	52.375 2.0620	38.481 1.5150	38.227 1.5050	1.52 0.060	IR-2824	44.442 1.7497	44.430 1.7492	44.453 1.7501	44.440 1.7496	1.761 0.396
1 13/16	46.025 1.8120	46.038 1.8125	52.388 2.0625	52.375 2.0620	25.781 1.0150	25.527 1.0050	1.52 0.060	IR-2916	46.030 1.8122	46.017 1.8117	46.040 1.8126	46.027 1.8121	0.952 0.214
	46.025 1.8120	46.038 1.8125	52.388 2.0625	52.375 2.0620	38.481 1.5150	38.227 1.5050	1.52 0.060	IR-2924	46.030 1.8122	46.017 1.8117	46.040 1.8126	46.027 1.8121	1.432 0.322
1 7/8	47.612 1.8745	47.625 1.8750	53.975 2.1250	53.962 2.1245	38.481 1.5150	38.227 1.5050	1.52 0.060	IR-3024	47.617 1.8747	47.605 1.8742	47.628 1.8751	47.615 1.8746	1.419 0.319
2 1/2	63.487 2.4995	63.500 2.5000	69.850 2.7500	69.837 2.7495	25.781 1.0150	25.527 1.0050	1.52 0.060	IR-4016	63.495 2.4998	63.477 2.4991	63.505 2.5002	63.487 2.4995	1.290 0.290

Bore and O.D. tolerance limits correspond to the single mean diameter (the arithmetical mean of the largest and smallest diameters in a single radial plane).
 $*r_{as max}$ is equal to minimum inner ring bore chamfer ($r_{s min}$) at unmarked end.

HEAVY-DUTY NEEDLE ROLLER BEARINGS

Overview: Heavy-duty needle roller bearings consist of a machined and ground channel-shaped outer ring with a complement of needle rollers retained and guided by a cage. The high-strength cage retains and guides the rollers. An optional lubrication groove and hole in the outer ring facilitate relubrication. These bearings can be used with or without a machined and ground inner ring, depending on the suitability of the shaft as a raceway surface.

- **Sizes: Metric:** 5 mm - 175 mm bore (0.19685 in. - 6.88976 in.).
- **Markets:** Gear pumps, sheaves, automotive transmissions and two-cycle engines.
- **Features:** Thick outer ring provides maximum load capacity and shock resistance with a relatively small radial cross section.
- **Benefits:** Optimum speed and lubrication-retention capability.

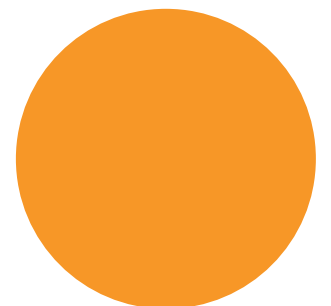
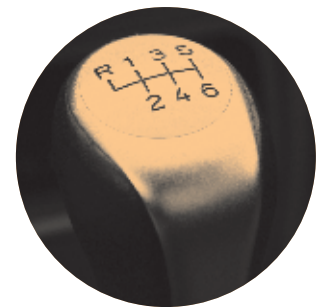
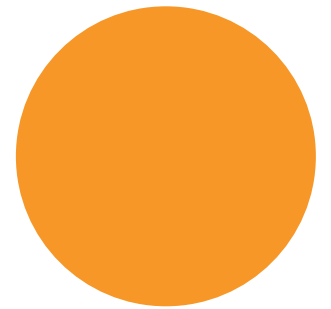

Needle Roller Bearings with Inner Rings – Metric Nominal Dimensions

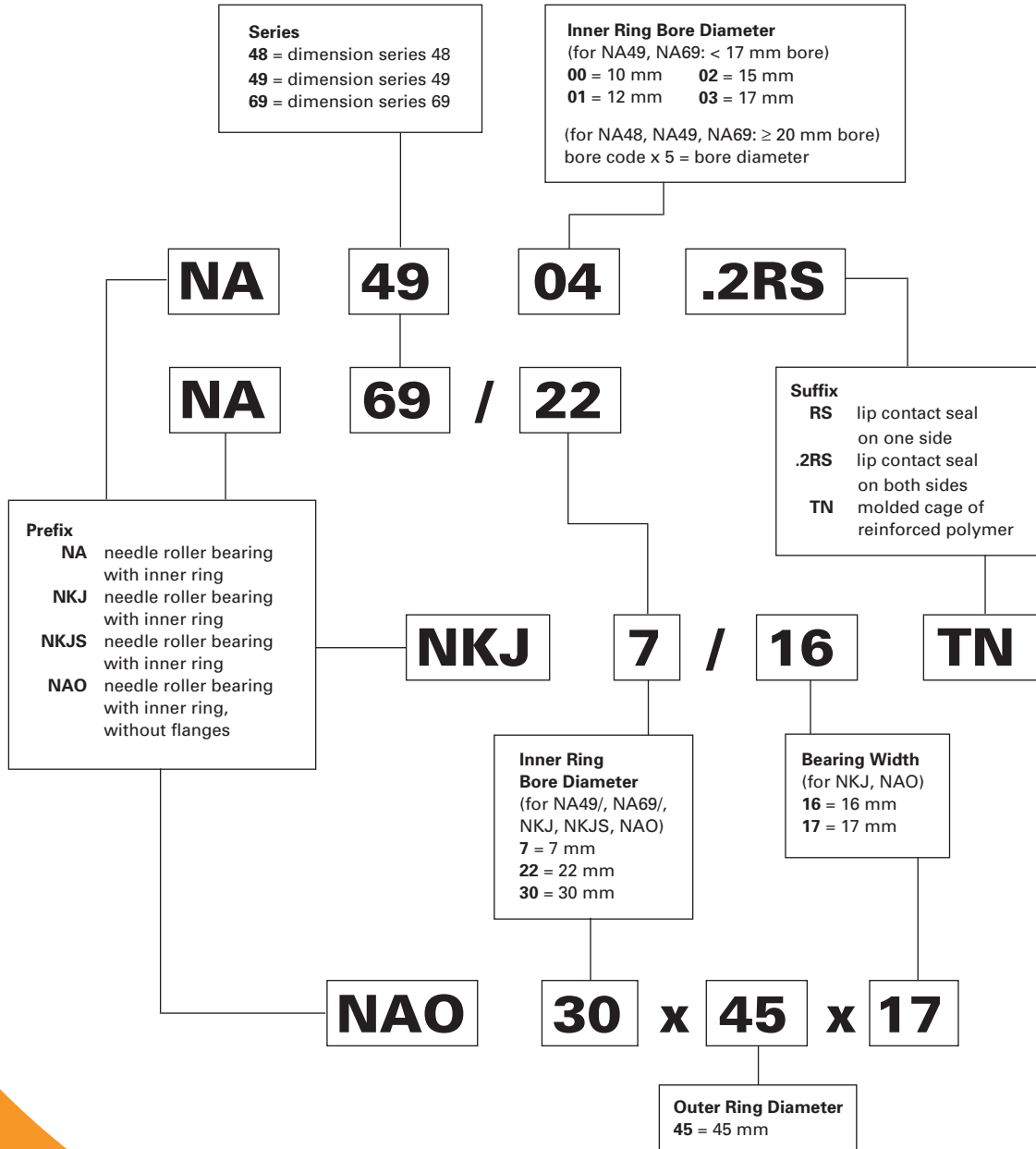

Needle Roller Bearings without Inner Rings – Metric Nominal Dimensions

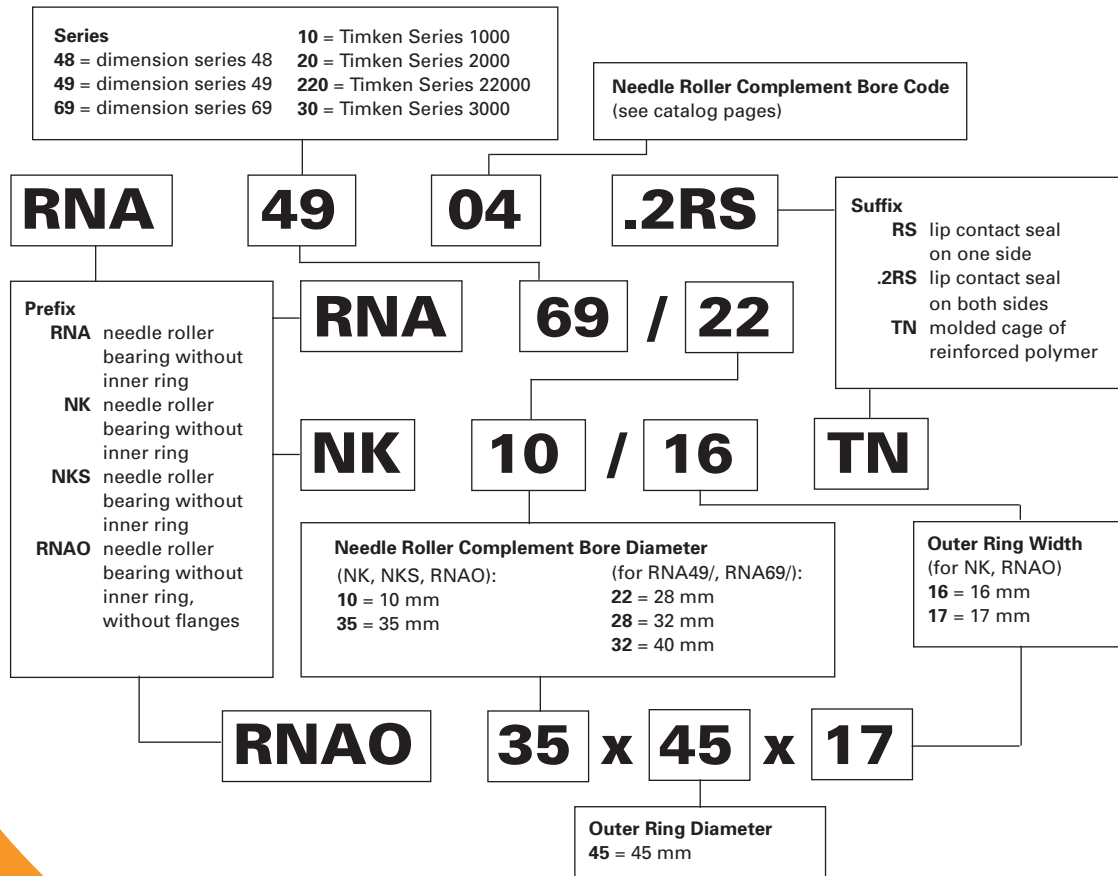

Inner Rings for Needle Roller Bearings – Metric Nominal Dimensions

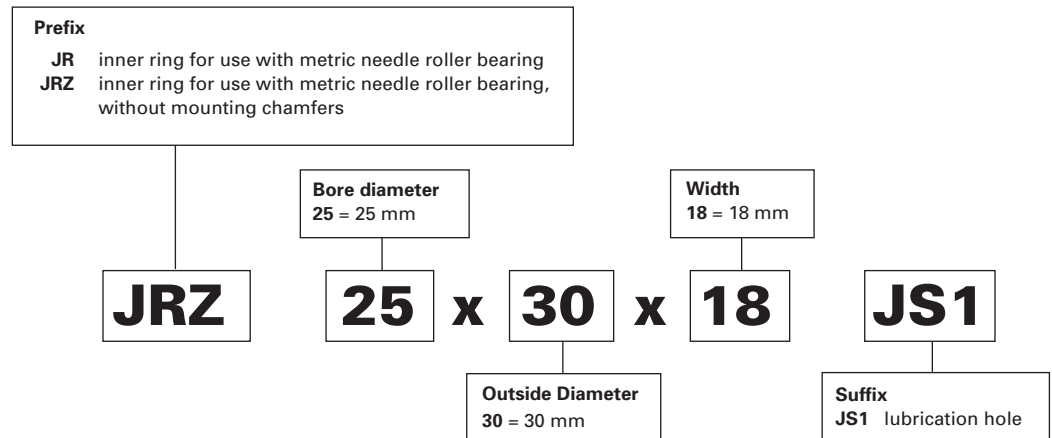

C



Heavy-Duty Needle Roller

	<i>Page</i>
Introduction	C100
 SINGLE-ROW RADIAL BEARINGS	
Introduction	C134
Nomogram For Determining The Allowable Axial Load	C137
Dimensional Accuracy, Bearings – Inch Series	C139
Dimensional Accuracy, Inner Rings – Inch Series	C140
Needle Roller Bearings – Inch Series	C142
 METRIC SERIES	
Needle Roller Bearings with Inner Rings	C105
Needle Roller Bearings Without Inner Rings	C111
Sealed Needle Roller Bearings With Inner Rings	C118
Sealed Needle Roller Bearings Without Inner Rings	C119
Needle Roller Bearings Without Flanges	
With Inner Rings	C120
Needle Roller Bearings Without Flanges	
Without Inner Rings	C123
Needle Roller Bearings Full Complement	
Without Inner Rings	C126
Needle Roller Bearings Full Complement	
With Inner Rings	C130

	<i>Page</i>
 NEEDLE ROLLER BEARINGS TYPE HJ	
Introduction	C141
 INCH SERIES	
HJ Type	C142
Sealed Heavy-duty Needle Roller Bearings	C148
Inner Ring	C152

C





NEEDLE ROLLER BEARINGS

METRIC SERIES

When applications involve very heavy dynamic, static or even shock load conditions the needle roller bearing may be found to give best results.

REFERENCE STANDARDS ARE:

- ISO 1206 – Needle roller bearings – Light and medium series – Dimensions and tolerances.
- DIN 617 – Rolling bearings – Needle roller bearings with cage – Dimension Series 48 and 49.

TYPES OF METRIC SERIES NEEDLE ROLLER BEARINGS

Needle roller bearings with inner rings

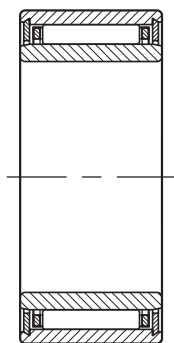

NKJ
($d \leq 7$ mm)

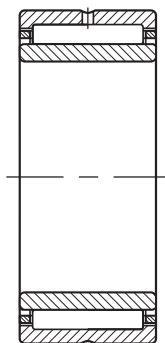

NKJ, NKJS
($d \geq 9$ mm)
NA48, NA49
NA69 ($d \leq 30$ mm)

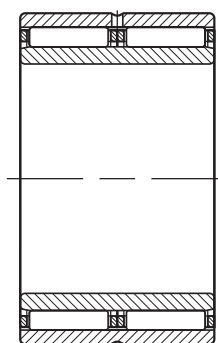

NA69
($d \geq 32$ mm)

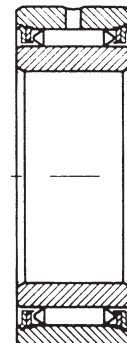

Full Complement

Needle roller bearings without inner rings

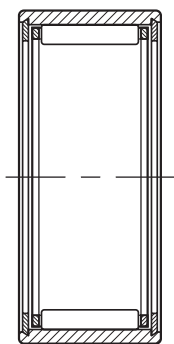

NK
($F_w \leq 10$ mm)

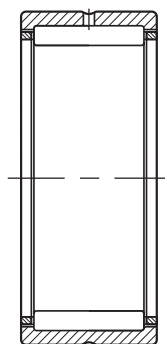

NK ($F_w \geq 12$ mm)
NKS, RNA48, RNA49
RNA69 ($F_w \leq 35$ mm)

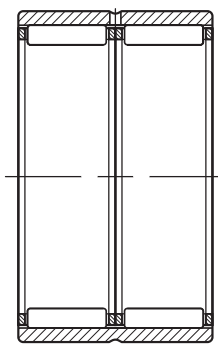

RNA69
($F_w \geq 40$ mm)

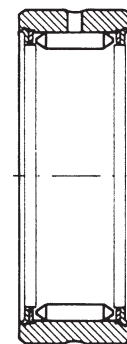

Full Complement

Sealed needle roller bearings with inner rings

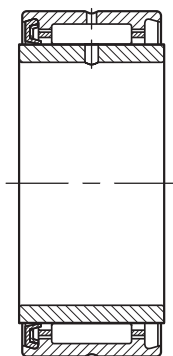

NA49RS

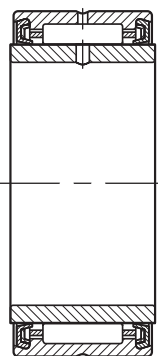

NA49.2RS

Sealed needle roller bearings without inner rings

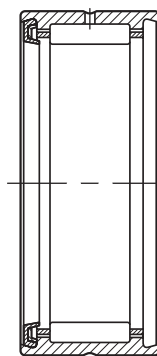

RNA49RS

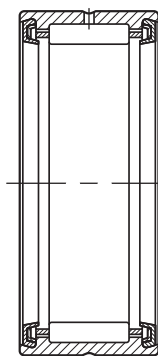

RNA49.2RS

**Needle roller bearings
without flanges,
with inner rings**

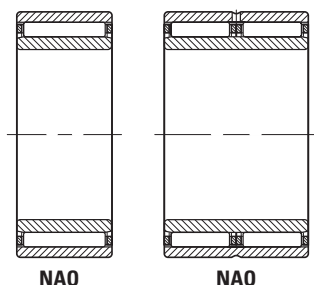

**Needle roller bearings
without flanges, without
inner rings**

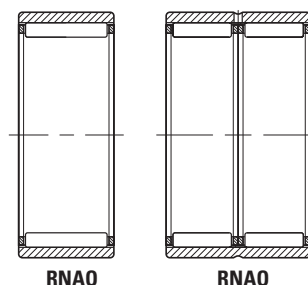

Suffixes

RS	One Seal
.2RS	Two Seals
TN	Molded Cage of Engineered Reinforced Polymer

CONSTRUCTION

The basic constructions of metric series needle roller bearings are:

- with integral end flanges on the one piece channel-shaped outer rings. ($F_w \geq 12$ mm)
- with inserted end washers to provide axial retention of the needle roller and cage assemblies. ($F_w \leq 10$ mm)
- without flanges where separate end washers or housing shoulders are required to provide axial retention of the needle roller and cage assemblies.
- full, outer ring-piloted complement of needle rollers (with or without inner ring).

METRIC SERIES NEEDLE ROLLER BEARINGS WITH INNER RINGS

When it is impractical to finish the shaft to meet the desired raceway design requirements, an inner ring may be used. Standard needle roller bearings are available with inner rings (such as the NA Series) forming complete bearings. Bearings furnished with inner rings meet the quality requirements in accordance with ISO standards.

- For inner and outer ring tolerances the metric series bearings follow the normal tolerance class in ISO Standard 492 covering radial bearings. Bearings to more precise tolerance classes P6 and P5 may be obtained upon request (see the engineering section).
- The metric series bearings may be obtained with radial internal clearance in accordance with ISO Standard 5753 also specified for cylindrical roller bearings. Mostly, they follow the normal (C0) radial clearance group although bearings to clearance groups C2, C3, and C4 may be made available on request (see the engineering section).
- Inner ring and outer ring chamfer dimensions meet the requirements of ISO Standard 582.

METRIC SERIES NEEDLE ROLLER BEARINGS WITHOUT INNER RINGS

Whenever the shaft can be used as the inner raceway, needle roller bearings without inner rings provide advantages of economy and close control of radial internal clearance in operation. Tolerance class F6 is the normal specification for the metric series needle roller complement bore diameter of an unmounted bearing as shown in Table 1. In the case of needle roller bearings of series RNAO, without flanges and without inner rings, the outer rings and needle roller and cage assemblies are not interchangeable.

TABLE 1 – METRIC SERIES CAGED NEEDLE ROLLER COMPLEMENT BORE DIAMETER FOR BEARINGS WITHOUT INNER RINGS.

mm		µm	
>	≤	low	high
F_w		ΔF_w min	
3	6	+10	+18
6	10	+13	+22
10	18	+16	+27
18	30	+20	+33
30	50	+25	+41
50	80	+30	+49
80	120	+36	+58
120	180	+43	+68
180	250	+50	+79
250	315	+56	+88
315	400	+62	+98



NEEDLE ROLLER BEARINGS

TABLE 1. A – FULL COMPLEMENT METRIC NEEDLE ROLLER COMPLEMENT BORE DIAMETER FOR BEARINGS WITHOUT INNER RINGS

mm		µm	
>	≤	low	high
F _w		ΔF _{us} min	
5	15	+20	+40
15	25	+20	+43
25	30	+25	+48
30	35	+30	+53
35	60	+35	+58
60	80	+45	+73
80	115	+50	+78
115	180	+60	+88
180	220	+70	+103
220	270	+80	+113
270	350	+90	+128

METRIC SERIES NEEDLE ROLLER BEARINGS WITH INTEGRAL FLANGES

The Timken® Torrington® needle roller bearing has a one-piece channel-shaped outer ring of bearing quality steel, heat treated to yield maximum load rating. The integral end flanges provide axial location for the needle rollers. The bores of the end flanges serve as piloting surfaces for the cage.

A steel cage provides inward retention for the needle rollers and the design assures roller stability and minimizes friction between the cage and the needle rollers. The cage has maximum strength consistent with the inherent high load ratings of needle roller bearings.

Needle roller bearings of series NKJ, NKJS, NA48, and NA49 contain one needle roller and cage assembly, bearings of series NA69 with bearing bores of 32 mm and above have two needle roller and cage assemblies.

The outer ring has a lubricating groove and a lubricating hole for more convenient lubrication of the bearing. However, the smaller bearings of series NKJ and NK have not have a lubricating groove or a lubricating hole. (F_w ≤ 10 mm)

METRIC SERIES NEEDLE ROLLER BEARINGS WITH INSERTED END WASHERS

Some metric series needle roller bearings have inserted end washers to provide axial retention of the needle roller and cage assembly. The needle roller and cage radial assemblies, consistent with other Timken Torrington designs, provide inward and outward retention for the needle rollers.

METRIC SERIES NEEDLE ROLLER BEARINGS WITHOUT FLANGES

The needle roller and cage radial assembly used in the metric series needle roller bearings without flanges is slightly narrower than the inner and outer rings to ensure unobstructed operation. Separate end washers are required to provide axial retention of the needle roller and cage radial assembly. Wide needle roller bearings using two needle roller and cage assemblies have a lubricating

groove and one lubricating hole in the outer ring to facilitate relubrication of the bearing. Narrow needle roller bearings do not have a lubricating groove or a lubricating hole in the outer ring.

SEALED METRIC SERIES NEEDLE ROLLER BEARINGS OF DIMENSION SERIES 49

Needle roller bearings of Series 49 are available with one or two integral lip contact seals as listed on page C118. One seal is designated by suffix letters RS. Two seals are designated by .2RS. When combining sealed metric series needle roller bearings with inner rings it is suggested to use inner rings shown on page C340 with designation JRZ because they are wider than the outer rings to ensure positive seal contact.

These seals limit the bearing operating temperature between -30° C and 110° C. If the operating temperature must be outside the above range or if the seals are exposed to unusual fluids, external seals using suitable seal materials or other solutions should be investigated. Sealed bearings are normally packed with a high quality lithium soap base grease suitable up to 120° C for short periods of operation.

The limiting speeds specified for sealed bearings listed in the bearing tables are based on operating conditions determined by testing. Optimum performance may be expected providing the bearing is properly installed, with appropriate internal clearances, and be subjected to a load of low magnitude. Care should be taken that overheating will not occur, thus preventing breakdown of the grease and eventual bearing failure.

METRIC SERIES FULL COMPLEMENT NEEDLE ROLLER BEARINGS

Series NA and RNA 1000, 2000, 22000 and 3000 are available with possible options of extra wide and/or crowned inner ring raceways. Consult your local Timken representative for application details.

BEARING MOUNTING

MOUNTING DIMENSIONS

It is suggested that needle roller bearings are mounted in their housings with a clearance fit if the load is stationary relative to the housing, or with a tight transition fit if the load rotates relative to the housing. Table 2 lists the suggested tolerances for the housing bore and the shaft raceway for metric series bearings without inner rings. Table 3 lists the suggested shaft tolerances for the above two mounting conditions when the metric series bearings are used with inner rings. The suggested housing bore tolerances for metric series bearings with inner rings is the same as the housing bore tolerance listed in Table 2 for metric series bearings without inner rings. Other quality requirements for shafts and housings are given in the engineering section of this catalog.

Other mounting dimensions may be required for special operating conditions such as:

1. Extremely heavy radial loads
2. Shock loads
3. Temperature gradient across bearing
4. Housing material with heat expansion coefficient different than that of the bearing
5. Oscillating motion applications

Regardless of the fit of the bearing outer ring in the housing, the outer ring should be axially located by housing shoulders or other positive means. The bearing rings should closely fit against the shaft and housing shoulders and must not contact the fillet radius. The maximum shaft or housing fillet $r_{as\ max}$ should be no greater than the minimum bearing chamfer $r_{s\ min}$ as shown in Table 4.

In order to permit mounting and dismounting of the shaft, the maximum diameter D_1 in Table 5 must not be exceeded. F_w is shown in the bearing tables.

TABLE 2 – MOUNTING TOLERANCES FOR METRIC SERIES BEARINGS WITHOUT INNER RING

Rotation conditions	Nominal housing bore diameter D mm	ISO tolerance zone for housing		Nominal shaft diameter F mm	ISO tolerance zone for shaft	
		caged	full		caged	full
Load stationary relative to housing	all diameters	H7	J6	all diameters	h6	h5
General work with larger clearance	all diameters	K7	—	all diameters	g6	—
Load rotates relative to housing	all diameters	N7	M6	all diameters	f6	g5

NOTE: Care should be taken that the selected bearing internal clearance is appropriate for the operating conditions. Details of shaft and housing quality requirements are given in the engineering section of this catalog.

TABLE 3 – SHAFT TOLERANCES FOR METRIC SERIES BEARINGS WITH INNER RINGS (USE HOUSING TOLERANCE SHOWN IN TABLE 2)

Rotation conditions	Nominal shaft diameter d, mm		ISO tolerance zone for shaft	
	>	≤	caged	full
load rotates relative to housing	all diameters		g6	h5 (h6)
load stationary relative to housing	>	40	k6	k5
	40	100	M6	M5
	100	140	M6	M5
	140		n6	n6

NOTE: Care should be taken that the selected bearing internal clearance is appropriate for the operating conditions. Details of shaft and housing quality requirements are given in the engineering section of this catalog.

Needle roller bearings without flanges of series RNAO and NAO must have the needle roller and cage radial assembly properly end guided by shoulders as shown in Table 6, or other suitable means such as the spring steel washers (SNSH) shown on page C349. These end guiding surfaces should be hardened and precision turned or ground to minimize wear and should properly fit against the outer rings and the inner rings to provide the desired end clearance for the needle roller and cage assembly.

TABLE 4 – FILLETS, UNDERCUTS, AND SHOULDER HEIGHTS FOR METRIC SERIES BEARINGS

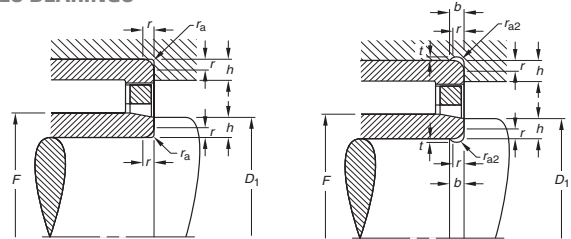

r_s Min. mm	r_{as} Max.	t	r_{a2s} Min.	b	h Min.
0.15	0.15				0.6
0.3	0.3				1
0.6	0.6				2
1	1	0.2	1.3	2	2.5
1.1	1	0.3	2	3	3.25
1.5	1.5	0.4	2	3.2	4
2	2	0.5	2.5	4	5
2.1	2.1	0.5	3	4.7	5.5
3	2.5	0.5	3.5	5.3	6

TABLE 5 – SHOULDER DIAMETER D_{1MAX} FOR METRIC SERIES BEARINGS

		Dimensions in mm				
Needle roller complement bore diameter F_w	>	20	55	100	250	
	≤	20	55	100	250	
Diameter	D_{1max}	$F_w - 0.3$	$F_w - 0.5$	$F_w - 0.7$	$F_w - 1$	$F_w - 1.5$



NEEDLE ROLLER BEARINGS

**TABLE 6 –
MOUNTING DIMENSIONS FOR
METRIC SERIES NEEDLE ROLLER
BEARINGS WITHOUT FLANGES**

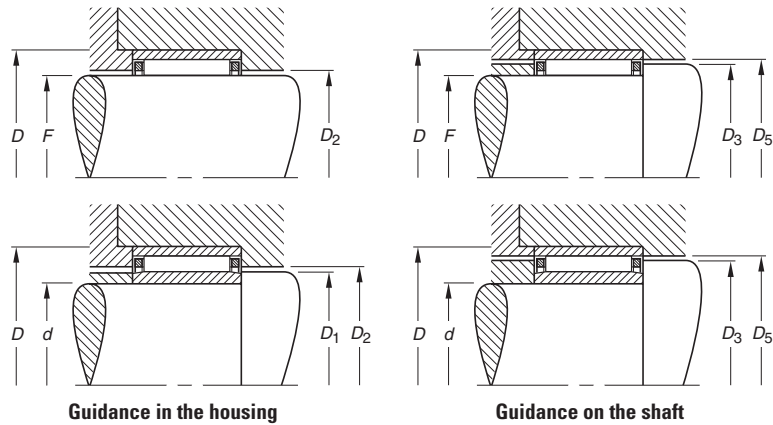

Guidance in the housing

Guidance on the shaft

Dimensions mm	Bearing Series RNAO		
	Min.	Max.	Min.
FxD	D ₂	D ₃	D ₅
10x17	10.3	12.7	13.3
12x19	12.3	14.7	15.3
14x22	14.4	17.6	18.3
15x23	15.4	18.6	19.3
16x24	16.4	19.6	20.3
17x25	17.4	20.6	21.3
18x26	18.4	21.6	22.3
18x30	18.6	23.6	24.5
20x28	20.4	23.6	24.3
20x32	20.6	25.6	26.5
22x30	22.4	25.6	26.3
22x35	22.8	28.4	29.5
25x35	25.6	29.4	30.5
25x37	25.8	31.4	32.5
28x40	28.8	34.4	35.5
30x40	30.6	34.4	35.5
30x42	30.8	36.4	37.5
35x45	35.6	39.4	40.5
35x47	35.8	41.4	42.5
40x50	40.6	44.4	45.5
40x55	41	47.2	48.5
45x55	45.6	49.4	50.5
45x62	46	52.2	53.5
50x62	50.6	54.4	55.8
50x65	51	57.2	58.5
55x68	55.6	59.4	60.8
55x72	56	62.2	63.8
60x78	61	67.2	68.8
65x85	66	72.2	73.8
70x90	71	77.2	78.8
75x95	76	82.2	84
80x100	81	87.2	89
85x105	86	92.2	94
90x110	91	97.2	99
95x115	96	102.2	104
100x120	101	107.2	109

Dimensions mm	Bearing Series NAO			
	Max.	Min.	Max.	Min.
dxD	D ₁	D ₂	D ₃	D ₅
6x17	9.7	10.3	12.7	13.3
8x19	11.7	12.3	14.7	15.3
10x22	13.7	14.4	17.6	18.3
10x26	13.7	14.6	19.6	20.3
12x24	15.7	16.4	19.6	20.3
12x28	15.7	16.6	21.6	22.3
15x28	19.5	20.4	23.6	24.3
15x32	19.5	20.6	25.6	26.5
17x30	21.5	22.4	25.6	26.3
17x35	21.5	22.8	28.4	29.5
20x35	24.5	25.6	29.4	30.5
20x37	24.5	25.8	31.4	32.5
25x40	29.5	30.6	34.4	35.5
25x42	29.5	30.8	36.4	37.5
30x45	34.5	35.6	39.4	40.5
30x47	34.5	35.8	41.4	42.5
35x50	39.5	40.6	44.4	45.5
35x55	39.5	41	47.2	48.5
40x55	44.5	45.6	49.4	50.5
40x62	44.5	46	52.2	53.5
45x62	49.5	50.6	54.4	55.8
45x72	54.5	56	62.2	63.8
50x68	54.5	55.6	59.4	60.8
50x78	59.3	61	67.2	68.8
55x85	64.3	66	72.2	73.8
60x90	69.3	71	77.2	78.8
65x95	74.3	76	82.2	84
70x100	79.3	81	87.2	89
75x105	84.3	86	92.2	94
80x110	89.3	91	97.2	99
85x115	94.3	96	102.2	104
90x120	99.3	101	107.2	109

LOAD RATING FACTORS

DYNAMIC LOADS

Needle roller bearings can accommodate only radial loads.

$$P = F_r \quad (\text{kN})$$

P = The maximum dynamic radial load that may be applied to a needle roller bearing based on the dynamic load rating C given in the tabular pages. This load should be $\leq C/3$.

STATIC LOADS

Needle roller bearings can accommodate only radial loads.

$$P_0 = F_r \quad (\text{kN})$$

MOUNTING IN SETS

Needle roller bearings which are mounted side by side or must have the same cross-section and radial internal clearances, after mounting.

**NEEDLE ROLLER BEARINGS
WITH INNER RINGS
METRIC SERIES**

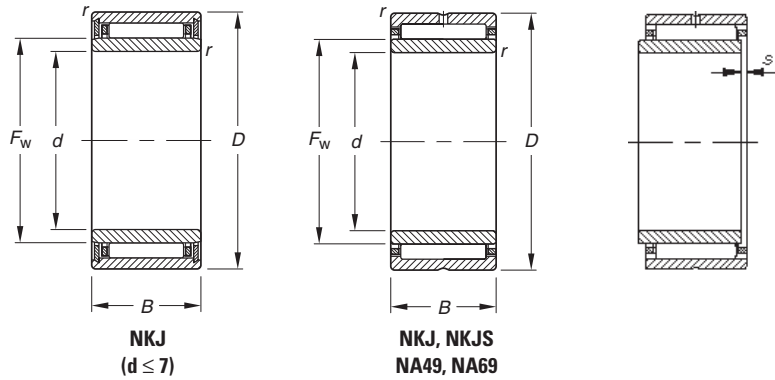

Shaft Diameter	Dimensions mm/in.						Bearing Designation	Load Ratings kN/lbf.		Limiting Speeds		Approx. Wt. kg/lbs.	
	mm	d	D	B	F _w	r _{s min}		s ¹	Dynamic C	Static C ₀	Oil RPM		Grease RPM
5	5	15	12	8	0.3	1.5	NKJ5/12	4.57	4.89	41000	26000	0.0148	0.014
	0.1969	0.5906	0.472	0.3150	0.012	0.059		1030	1100			0.031	
5	5	15	16	8	0.3	1.5	NKJ5/16	5.22	5.78	41000	26000	0.0154	0.017
	0.1969	0.5906	0.630	0.3150	0.012	0.059		1170	1300			0.037	
6	6	16	12	9	0.3	1.5	NKJ6/12	4.27	4.60	40000	26000	0.0153	0.015
	0.2362	0.6299	0.472	0.3543	0.012	0.059		960	1030			0.033	
6	6	16	16	9	0.3	1.5	NKJ6/16	5.57	6.47	40000	26000	0.0167	0.019
	0.2362	0.6299	0.630	0.3543	0.012	0.059		1250	1450			0.042	
7	7	17	12	11.5	0.3	1.5	NKJ7/12	5.40	6.43	39000	25000	0.0174	0.017
	0.2756	0.6693	0.472	0.4528	0.012	0.059		1210	1450			0.037	
7	7	17	16	11.5	0.3	1.5	NKJ7/16TN	5.30	6.27	39000	25000	0.0173	0.021
	0.2756	0.6693	0.630	0.4528	0.012	0.059		1190	1410			0.046	
9	9	19	12	12	0.3	1.5	NKJ9/12	6.86	7.60	30000	19000	0.0189	0.018
	0.3543	0.7480	0.472	0.4724	0.012	0.059		1540	1710			0.040	
9	9	19	16	12	0.3	1.5	NKJ9/16	6.78	9.03	30000	19000	0.0204	0.024
	0.3543	0.7480	0.630	0.4724	0.012	0.059		1520	2030			0.053	
10	10	22	13	14	0.3	1.0	NA4900	9.39	10.3	24000	16000	0.0211	0.025
	0.3937	0.8661	0.512	0.5512	0.012	0.039		2110	2320			0.055	
10	10	22	16	14	0.6	1.5	NKJ10/16	12.4	14.8	24000	16000	0.0231	0.032
	0.3937	0.8661	0.630	0.5512	0.024	0.059		2790	3330			0.071	
10	10	22	20	14	0.3	1.5	NKJ10/20	14.7	18.4	24000	16000	0.0244	0.040
	0.3937	0.8661	0.787	0.5512	0.012	0.059		3300	4140			0.088	
12	12	24	13	16	0.3	1.0	NA4901	10.5	12.0	28000	18000	0.0233	0.028
	0.4724	0.9449	0.512	0.6299	0.012	0.039		2360	2700			0.062	
12	12	24	16	16	0.3	1.5	NKJ12/16	13.0	16.2	28000	18000	0.0250	0.036
	0.4724	0.9449	0.630	0.6299	0.012	0.059		2920	3640			0.079	
12	12	24	20	16	0.3	1.5	NKJ12/20	15.4	20.2	28000	18000	0.0264	0.046
	0.4724	0.9449	0.787	0.6299	0.012	0.059		3460	4540			0.101	
12	12	24	22	16	0.3	1.0	NA6901	16.1	21.3	28000	18000	0.0267	0.051
	0.4724	0.9449	0.866	0.6299	0.012	0.039		3620	4790			0.11	
15	15	27	16	19	0.3	1.5	NKJ15/16	14.1	19.0	24000	15000	0.0279	0.042
	0.5906	1.0630	0.630	0.7480	0.012	0.059		3170	4270			0.093	
15	15	27	20	19	0.3	1.5	NKJ15/20	16.8	23.6	24000	15000	0.0295	0.054
	0.5906	1.0630	0.787	0.7480	0.012	0.059		3780	5310			0.119	
15	15	28	13	20	0.3	1.0	NA4902	11.8	15.3	22000	14000	0.0270	0.037
	0.5906	1.1024	0.512	0.7874	0.012	0.039		2650	3440			0.082	
15	15	28	23	20	0.3	1.5	NA6902	18.4	26.9	22000	14000	0.0311	0.067
	0.5906	1.1024	0.906	0.7874	0.012	0.059		4140	6050			0.148	
17	17	29	16	21	0.3	2.0	NKJ17/16	15.3	21.6	21000	14000	0.0301	0.047
	0.6693	1.1417	0.630	0.8268	0.012	0.079		3440	4860			0.104	
17	17	29	20	21	0.3	1.5	NKJ17/20	18.1	23.9	21000	14000	0.0317	0.059
	0.6693	1.1417	0.787	0.8268	0.012	0.059		4070	5370			0.130	
17	17	30	13	22	0.3	1.0	NA4903	12.2	16.4	20000	13000	0.0286	0.040
	0.6693	1.1811	0.512	0.8661	0.012	0.039		2740	3690			0.088	

⁽¹⁾ Max. axial displacement

Continued on next page.



NEEDLE ROLLER BEARINGS WITH INNER RINGS – *continued*

METRIC SERIES

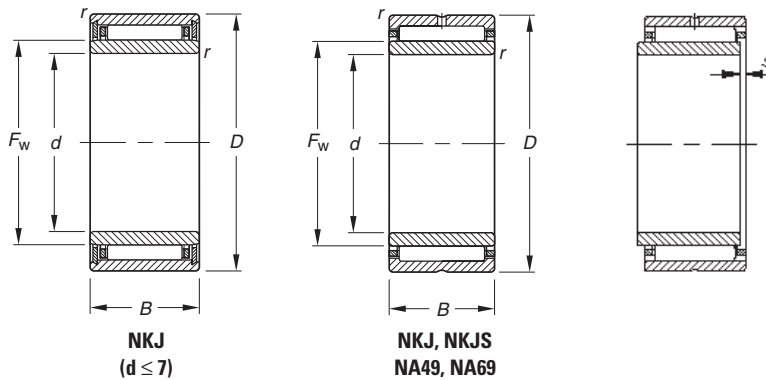

Shaft Diameter	Dimensions mm/in.						Bearing Designation	Load Ratings kN/lbf.		Limiting Speeds		Approx. Wt. kg/lbs.	
	mm	d	D	B	F _w	r _s min		s ¹	Dynamic C	Static C ₀	Oil Grease RPM		C _g
	17	30	23	22	0.6	1.0	NA6903	19.8	30.6	20000	13000	0.0334	0.084
	0.6693	1.1811	0.906	0.8661	0.024	0.039		4450	6880				
	17	37	20	24	0.6	1.0	NKJS17	29.1	32.8	20000	13000	0.0325	0.108
	0.6693	1.4567	0.787	0.9449	0.024	0.039		6540	7370				
20	20	32	16	24	0.3	1.5	NKJ20/16	16.2	24.3	18000	12000	0.0328	0.053
	0.7874	1.2598	0.630	0.9449	0.012	0.059		3640	5460				
	20	32	20	24	0.3	1.5	NKJ20/20	19.3	30.3	18000	12000	0.0346	0.067
	0.7874	1.2598	0.787	0.9449	0.012	0.059		4340	6810				
	20	37	17	25	0.3	1.5	NA4904	21.3	25.5	18000	12000	0.0318	0.084
	0.7874	1.4567	0.669	0.9843	0.012	0.059		4790	5730				
	20	37	30	25	0.3	1.5	NA6904	36.6	51.0	18000	12000	0.0378	0.133
	0.7874	1.4567	1.181	0.9843	0.012	0.059		8230	11500				
	20	42	20	28	0.6	1.0	NKJS20	30.3	38.4	16000	11000	0.0364	0.130
	0.7874	1.6535	0.787	1.1024	0.024	0.039		6810	8630				
22	22	34	16	26	0.3	1.5	NKJ22/16	16.6	25.7	17000	11000	0.0344	0.058
	0.8661	1.3386	0.630	1.0236	0.012	0.059		3730	5780				
	22	34	20	26	0.3	2.0	NKJ22/20	19.7	32.0	17000	11000	0.0363	0.071
	0.8661	1.3386	0.787	1.0236	0.012	0.079		4430	7190				
	22	39	17	28	0.3	1.5	NA49/22	23.3	29.6	16000	10000	0.0346	0.089
	0.8661	1.5354	0.669	1.1024	0.012	0.059		5240	6650				
	22	39	30	28	0.3	1.0	NA69/22	30.6	50.7	16000	10000	0.0487	0.163
	0.8661	1.5354	1.181	1.1024	0.012	0.039		6880	11400				
25	25	38	20	29	0.3	2.0	NKJ25/20	23.4	36.4	15000	9800	0.0383	0.086
	0.9843	1.4961	0.787	1.1417	0.012	0.079		5260	8180				
	25	38	30	29	0.3	2.0	NKJ25/30	29.8	56.4	15000	9800	0.0438	0.130
	0.9843	1.4961	1.181	1.1417	0.012	0.079		6700	12700				
	25	42	17	30	0.3	1.5	NA4905	24.3	31.7	15000	9700	0.0362	0.099
	0.9843	1.6535	0.669	1.1811	0.012	0.059		5460	7130				
	25	42	30	30	0.3	1.5	NA6905	39.7	59.6	15000	9700	0.0424	0.178
	0.9843	1.6535	1.181	1.1811	0.012	0.059		8920	13400				
	25	47	22	32	0.6	1.5	NKJS25	36.0	36.2	14000	9200	0.0398	0.174
	0.9843	1.8504	0.866	1.2598	0.024	0.059		8090	8140				
28	28	42	20	32	0.3	2.0	NKJ28/20	24.8	40.4	14000	8800	0.0411	0.104
	1.1024	1.6535	0.787	1.2598	0.012	0.079		5580	9080				
	28	42	30	32	0.3	2.0	NKJ28/30	35.6	64.3	14000	8800	0.0461	0.156
	1.1024	1.6535	1.181	1.2598	0.012	0.079		8000	14500				
	28	45	17	32	0.3	1.5	NA49/28	25.1	33.8	14000	9000	0.0378	0.108
	1.1024	1.7717	0.669	1.2598	0.012	0.059		5640	7600				
	28	45	30	32	0.3	1.5	NA69/28	37.1	55.4	14000	9000	0.0434	0.190
	1.1024	1.7717	1.181	1.2598	0.012	0.059		8340	12500				
30	30	45	20	35	0.3	1.5	NKJ30/20	26.1	44.4	12000	8000	0.0437	0.120
	1.1811	1.7717	0.787	1.3780	0.012	0.059		5870	9980				
	30	45	30	35	0.3	1.5	NKJ30/30	37.4	70.6	12000	8000	0.0491	0.179
	1.1811	1.7717	1.181	1.3780	0.012	0.059		8410	15900				

⁽¹⁾ Max. axial displacement

Continued on next page.

Shaft Diameter	Dimensions mm/in.						Bearing Designation	Load Ratings kN/lbf.		Limiting Speeds		Approx. Wt. kg/lbs.	
	mm	d	D	B	F _w	r _s min		s ¹	Dynamic C	Static C ₀	Oil RPM		Grease RPM
30	30	47	17	35	0.3	1.5	NA4906	25.9	36.0	13000	8200	0.0399	0.114
	1.1811	1.8504	0.669	1.3780	0.012	0.059		5820	8090				
30	30	47	30	35	0.3	1.0	NA6906	42.6	68.2	13000	8200	0.0467	0.205
	1.1811	1.8504	1.181	1.3780	0.012	0.039		9580	15300				
30	30	52	22	37	0.6	1.5	NKJS30	39.0	53.4	12000	7900	0.0438	0.198
	1.1811	2.0472	0.866	1.4567	0.024	0.059		8770	12000				
32	32	47	20	37	0.3	2.0	NKJ32/20	26.6	46.4	12000	7600	0.0453	0.127
	1.2598	1.8504	0.787	1.4567	0.012	0.079		5980	10400				
32	32	47	30	37	0.3	1.5	NKJ32/30	38.2	73.9	12000	7600	0.0508	0.192
	1.2598	1.8504	1.181	1.4567	0.012	0.059		8590	16600				
32	32	52	20	40	0.6	1.5	NA49/32	32.0	49.3	11000	7100	0.0457	0.169
	1.2598	2.0472	0.787	1.5748	0.024	0.059		7190	11100				
32	32	52	36	40	0.6	1.0	NA69/32	48.6	84.5	11000	7100	0.0620	0.313
	1.2598	2.0472	1.417	1.5748	0.024	0.039		10900	19000				
35	35	50	20	40	0.3	2.0	NKJ35/20	27.8	50.4	11000	7000	0.0479	0.135
	1.3780	1.9685	0.787	1.5748	0.012	0.079		6250	11300				
35	35	50	30	40	0.3	1.5	NKJ35/30	40.0	80.2	11000	7000	0.0537	0.208
	1.3780	1.9685	1.181	1.5748	0.012	0.059		8990	18000				
35	35	55	20	42	0.6	1.5	NA4907	32.8	51.7	10000	6700	0.0472	0.179
	1.3780	2.1654	0.787	1.6535	0.024	0.059		7370	11600				
35	35	55	36	42	0.6	1.0	NA6907	49.9	88.7	10000	6700	0.0540	0.340
	1.3780	2.1654	1.417	1.6535	0.024	0.039		11200	19900				
35	35	58	22	43	0.6	1.0	NKJS35	41.6	60.7	10000	6700	0.0481	0.235
	1.3780	2.2835	0.866	1.6929	0.024	0.039		9350	13600				
38	38	53	20	43	0.3	2.0	NKJ38/20	29.0	54.4	9900	6400	0.0504	0.146
	1.4961	2.0866	0.787	1.6929	0.012	0.079		6520	12200				
38	38	53	30	43	0.3	1.5	NKJ38/30	41.6	86.6	9900	6400	0.0565	0.196
	1.4961	2.0866	1.181	1.6929	0.012	0.059		9350	19500				
40	40	55	20	45	0.3	2.0	NKJ40/20	29.5	56.4	9400	6100	0.0519	0.152
	1.5748	2.1654	0.787	1.7717	0.012	0.079		6630	12700				
40	40	55	30	45	0.3	1.5	NKJ40/30	42.3	89.8	9400	6100	0.0582	0.229
	1.5748	2.1654	1.181	1.7717	0.012	0.059		9510	20200				
40	40	62	22	48	0.6	1.5	NA4908	44.2	67.8	9100	5900	0.0519	0.248
	1.5748	2.4409	0.866	1.8898	0.024	0.059		9940	15200				
40	40	62	40	48	0.6	1.5	NA6908	70.8	124	9100	5900	0.0717	0.473
	1.5748	2.4409	1.575	1.8898	0.024	0.059		15900	27900				
40	40	65	22	50	1.0	1.0	NKJS40	45.5	71.3	8700	5700	0.0535	0.292
	1.5748	2.5591	0.866	1.9685	0.039	0.039		10200	16000				
42	42	57	20	47	0.3	2.0	NKJ42/20	30.0	58.5	9000	5900	0.0534	0.159
	1.6535	2.2441	0.787	1.8504	0.012	0.079		6740	13200				
42	42	57	30	47	0.3	1.5	NKJ42/30	39.9	84.1	9000	5900	0.0584	0.241
	1.6535	2.2441	1.181	1.8504	0.012	0.059		8970	18900				
45	45	62	25	50	0.6	3.0	NKJ45/25	40.7	79.3	8500	5500	0.0580	0.223
	1.7717	2.4409	0.984	1.9685	0.024	0.118		9150	17800				
45	45	62	35	50	0.6	3.0	NKJ45/35	55.0	117	8500	5500	0.0636	0.345
	1.7717	2.4409	1.378	1.9685	0.024	0.118		12400	26300				
45	45	68	22	52	0.6	2.0	NA4909	46.8	74.8	8400	5400	0.0550	0.291
	1.7717	2.6772	0.866	2.0472	0.024	0.079		10500	16800				
45	45	68	40	52	0.6	1.5	NA6909	74.7	137	8400	5400	0.0759	0.55
	1.7717	2.6772	1.575	2.0472	0.024	0.059		16800	30800				
45	45	72	22	55	1.0	1.0	NKJS45	47.9	78.4	7900	5100	0.0571	0.360
	1.7717	2.8346	0.866	2.1654	0.039	0.039		10800	17600				
50	50	68	25	55	0.6	3.0	NKJ50/25	46.1	87.3	7800	5000	0.0605	0.288
	1.9685	2.6772	0.984	2.1654	0.024	0.118		10400	19600				
50	50	68	35	55	0.6	3.0	NKJ50/35	62.3	129	7800	5000	0.0667	0.406
	1.9685	2.6772	1.378	2.1654	0.024	0.118		14000	29000				
50	50	72	22	58	0.6	2.0	NA4910	48.9	82.0	7400	4800	0.0591	0.296
	1.9685	2.8346	0.866	2.2835	0.024	0.079		11000	18400				

⁽¹⁾ Max. axial displacement

Continued on next page.



NEEDLE ROLLER BEARINGS WITH INNER RINGS — *continued* METRIC SERIES

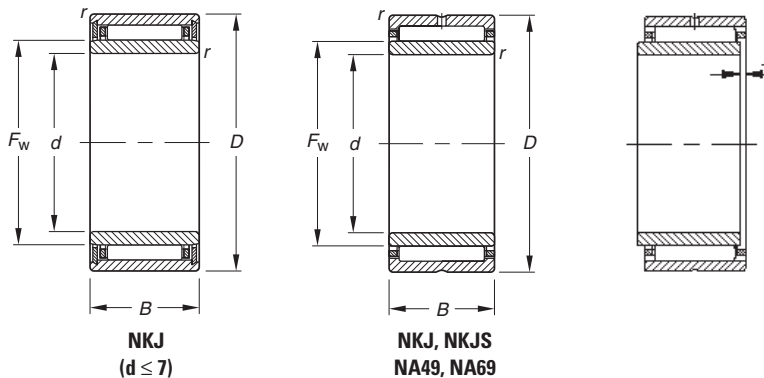

C

Shaft Diameter	Dimensions mm/in.						Bearing Designation	Load Ratings kN/lbf.		Limiting Speeds		Approx. Wt. kg/lbs.	
	mm	d	D	B	F _w	r _s min		s ¹	Dynamic C	Static C ₀	Oil Grease RPM		C _g
	50	72	40	58	0.6	1.5	NA6910	75.7	144	7400	4800	0.0806	0.577
	1.9685	2.8346	1.575	2.2835	0.024	0.059		17000	32400			0.0806	1.272
	50	80	28	60	1.1	1.5	NKJS50	66.9	103	7300	4800	0.0612	0.523
	1.9685	3.1496	1.102	2.3622	0.043	0.059		15000	23200			0.0612	1.153
55	55	72	25	60	0.6	3.0	NKJ55/25	44.3	94.0	7000	4600	0.0654	0.290
	2.1654	2.8346	0.984	2.3622	0.024	0.118		9960	21100			0.0654	0.639
	55	72	35	60	0.6	3.0	NKJ55/35	59.9	139	7000	4600	0.0721	0.410
	2.1654	2.8346	1.378	2.3622	0.024	0.118		13500	31200			0.0721	0.904
	55	80	25	63	1.0	2.5	NA4911	62.0	107	6900	4500	0.0645	0.426
	2.1654	3.1496	0.984	2.4803	0.039	0.098		13900	24100			0.0645	0.939
	55	80	45	63	1.0	2.5	NA6911	94.2	172	6900	4500	0.0852	0.800
	2.1654	3.1496	1.772	2.4803	0.039	0.098		21200	38700			0.0852	1.764
	55	85	28	65	1.1	1.5	NKJS55	71.0	114	6700	4400	0.0650	0.569
	2.1654	3.3465	1.102	2.5591	0.043	0.059		16000	25600			0.0650	1.254
60	60	82	25	68	0.6	2.0	NKJ60/25	49.0	101	6200	4000	0.0691	0.440
	2.3622	3.2283	0.984	2.6772	0.024	0.079		11000	22700			0.0691	0.970
	60	82	35	68	0.6	2.5	NKJ60/35	66.2	149	6200	4000	0.0760	0.520
	2.3622	3.2283	1.378	2.6772	0.024	0.098		14900	33500			0.0760	1.146
	60	85	25	68	1.0	1.5	NA4912	64.8	116	6300	4100	0.0681	0.457
	2.3622	3.3465	0.984	2.6772	0.039	0.059		14600	26100			0.0681	1.008
	60	85	45	68	1.0	2.0	NA6912	99.3	189	6400	4100	0.0901	0.829
	2.3622	3.3465	1.772	2.6772	0.039	0.079		22300	42500			0.0901	1.828
	60	90	28	70	1.1	1.5	NKJS60	72.6	120	6200	4000	0.0679	0.607
	2.3622	3.5433	1.102	2.7559	0.043	0.059		16300	27000			0.0679	1.338
65	65	90	25	72	1.0	1.5	NA4913	66.0	121	5900	3900	0.0705	0.489
	2.5591	3.5433	0.984	2.8346	0.039	0.059		14800	27200			0.0705	1.078
	65	90	25	73	0.6	2.0	NKJ65/25	61.5	119	5800	3800	0.0717	0.500
	2.5591	3.5433	0.984	2.8740	0.024	0.079		13800	26800			0.0717	1.102
	65	90	35	73	0.6	2.0	NKJ65/35	82.5	173	5800	3800	0.0787	0.690
	2.5591	3.5433	1.378	2.8740	0.024	0.079		18500	38900			0.0787	1.521
	65	90	45	72	1.0	2.0	NA6913	107	213	6000	3900	0.0952	0.945
	2.5591	3.5433	1.772	2.8346	0.039	0.079		24100	47900			0.0952	2.083
	65	95	28	75	1.1	1.5	NKJS65	76.5	132	5800	3700	0.0716	0.655
	2.5591	3.7402	1.102	2.9528	0.043	0.059		17200	29700			0.0716	1.444
70	70	95	25	80	1.0	2.0	NKJ70/25	65.0	131	5300	3400	0.0766	0.561
	2.7559	3.7402	0.984	3.1496	0.039	0.079		14600	29400			0.0766	1.237
	70	95	35	80	1.0	3.5	NKJ70/35	79.7	184	5300	3400	0.0846	0.779
	2.7559	3.7402	1.378	3.1496	0.039	0.138		17900	41400			0.0846	1.717
	70	100	28	80	1.1	1.5	NKJS70	80.1	143	5400	3500	0.0752	0.772
	2.7559	3.9370	1.102	3.1496	0.043	0.059		18000	32100			0.0752	1.702
	70	100	30	80	1.0	2.5	NA4914	86.3	157	5400	3500	0.0770	0.772
	2.7559	3.9370	1.181	3.1496	0.039	0.098		19400	35300			0.0770	1.702
	70	100	54	80	1.0	2.0	NA6914	137	286	5400	3500	0.1061	1.450
	2.7559	3.9370	2.126	3.1496	0.039	0.079		30800	64300			0.1061	3.197

⁽¹⁾ Max. axial displacement

Continued on next page.

Shaft Diameter	Dimensions mm/in.						Bearing Designation	Load Ratings kN/lbf.		Limiting Speeds		Approx. Wt. kg/lbs.	
	mm	d	D	B	F _w	r _{s min}		s ¹	Dynamic C	Static C ₀	Oil RPM		Grease RPM
75	75	105	25	85	1.0	2.0	NKJ75/25	76.4	137	5000	3300	0.0764	0.640
	2.9528	4.1339	0.984	3.3465	0.039	0.079		17200	30800				1.411
75	75	105	30	85	1.0	2.5	NA4915	92.4	175	5000	3300	0.0812	0.817
	2.9528	4.1339	1.181	3.3465	0.039	0.098		20800	39300				1.801
75	75	105	32	90	1.1	1.5	NKJS75	91.5	176	4700	3100	0.0834	1.060
	2.9528	4.1339	1.260	3.5433	0.043	0.059		20600	39600				2.337
75	75	105	35	85	1.0	2.0	NKJ75/35	108	214	5000	3300	0.0854	1.050
	2.9528	4.1339	1.378	3.3465	0.039	0.079		24300	48100				2.315
75	75	105	54	85	1.0	2.0	NA6915	143	308	5000	3300	0.1110	1.554
	2.9528	4.1339	2.126	3.3465	0.039	0.079		32100	69200				3.426
80	80	110	25	90	1.0	2.0	NKJ80/25	79.5	147	4700	3100	0.0798	0.790
	3.1496	4.3307	0.984	3.5433	0.039	0.079		17900	33000				1.742
80	80	110	30	90	1.0	2.5	NA4916	91.5	176	4700	3100	0.0834	0.862
	3.1496	4.3307	1.181	3.5433	0.039	0.098		20600	39600				1.900
80	80	110	32	95	1.1	2.0	NKJS80	95.1	188	4500	2900	0.0869	1.140
	3.1496	4.3307	1.260	3.7402	0.043	0.079		21400	42300				2.513
80	80	110	35	90	1.0	2.0	NKJ80/35	113	230	4700	3100	0.0891	0.980
	3.1496	4.3307	1.378	3.5433	0.039	0.079		25400	51700				2.161
80	80	110	54	90	1.0	2.0	NA6916	126	320	4700	3000	0.1197	1.615
	3.1496	4.3307	2.126	3.5433	0.039	0.079		28300	71900				3.560
85	85	115	26	95	1.0	3.0	NKJ85/26	49.3	114	4400	2800	0.0839	0.862
	3.3465	4.5276	1.024	3.7402	0.039	0.118		11100	25600				1.900
85	85	115	36	95	1.0	2.0	NKJ85/36	114	238	4400	2800	0.0921	1.040
	3.3465	4.5276	1.417	3.7402	0.039	0.079		25600	53500				2.293
85	85	120	30	100	1.1	2.5	NA4917	110	230	4200	2800	0.0935	1.310
	3.3465	4.7244	1.181	3.9370	0.043	0.098		24700	51700				2.888
85	85	120	63	100	1.1	2.0	NA6917	150	416	4200	2700	0.1340	2.427
	3.3465	4.7244	2.480	3.9370	0.043	0.079		33700	93500				5.351
90	90	120	26	100	1.0	3.0	NKJ90/26	83.6	163	4200	2800	0.0857	0.780
	3.5433	4.7244	1.024	3.9370	0.039	0.118		18800	36600				1.720
90	90	120	36	100	1.0	2.5	NKJ90/36	118	254	4200	2800	0.0958	1.080
	3.5433	4.7244	1.417	3.9370	0.039	0.098		26500	57100				2.381
90	90	125	35	105	1.1	2.5	NA4918	114	245	4000	2600	0.0970	1.370
	3.5433	4.9213	1.378	4.1339	0.043	0.098		25600	55100				3.020
90	90	125	63	105	1.1	2.0	NA6918	175	427	4000	2600	0.1323	2.640
	3.5433	4.9213	2.480	4.1339	0.043	0.079		39300	96000				5.820
95	95	125	26	105	1.0	2.5	NKJ95/26	52.2	127	3900	2600	0.0892	0.935
	3.7402	4.9213	1.024	4.1339	0.039	0.098		11700	28600				2.061
95	95	125	36	105	1.0	3.5	NKJ95/36	72.8	195	3900	2600	0.0992	1.300
	3.7402	4.9213	1.417	4.1339	0.039	0.138		16400	43800				2.866
95	95	130	35	110	1.1	2.5	NA4919	115	253	3800	2500	0.0999	1.430
	3.7402	5.1181	1.378	4.3307	0.043	0.098		25900	56900				3.153
95	95	130	63	110	1.1	2.0	NA6919	158	458	3800	2500	0.1434	2.670
	3.7402	5.1181	2.480	4.3307	0.043	0.079		35500	103000				5.88
100	100	130	30	110	1.1	2.0	NKJ100/30	103	220	3800	2500	0.0965	0.984
	3.9370	5.1181	1.181	4.3307	0.043	0.079		23200	49500				2.169
100	100	130	40	110	1.1	2.0	NKJ100/40	132	301	3800	2500	0.1043	1.410
	3.9370	5.1181	1.575	4.3307	0.043	0.079		29700	67700				3.109
100	100	135	32	115	1.1	2.0	NKJS100	104	226	3700	2400	0.0991	2.010
	3.9370	5.3150	1.260	4.5276	0.043	0.079		23400	50800				4.431
100	100	140	40	115	1.1	3.5	NA4920	139	296	3700	2400	0.1037	2.010
	3.9370	5.5118	1.575	4.5276	0.043	0.138		31200	66500				4.431
110	110	140	30	120	1.0	0.5	NA4822	90.3	230	3500	2300	0.1059	1.210
	4.3307	5.5118	1.181	4.7244	0.039	0.020		20300	51700				2.668
110	110	150	40	125	1.1	3.5	NA4922	147	325	3400	2200	0.1101	2.190
	4.3307	5.9055	1.575	4.9213	0.043	0.138		33000	73100				4.828
120	120	150	30	130	1.0	0.5	NA4824	94.2	249	3200	2100	0.1121	1.310
	4.7244	5.9055	1.181	5.1181	0.039	0.020		21200	56000				2.888

⁽¹⁾ Max. axial displacement

Continued on next page.



NEEDLE ROLLER BEARINGS

NEEDLE ROLLER BEARINGS WITH INNER RINGS – *continued*

METRIC SERIES

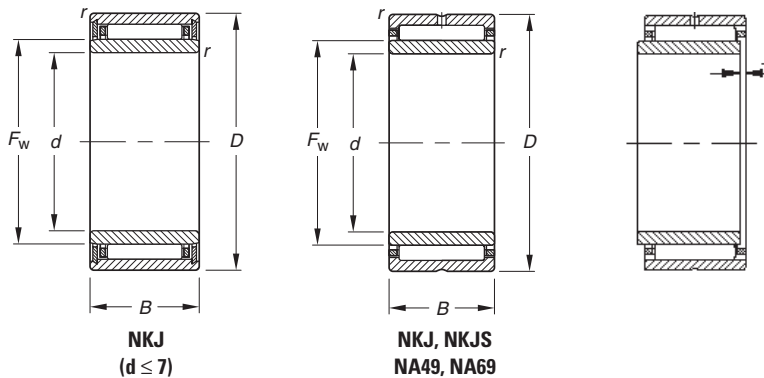

C

Shaft Diameter	Dimensions mm/in.						Bearing Designation	Load Ratings kN/lbf.		Limiting Speeds		Approx. Wt. kg/lbs.	
	mm	d	D	B	F _w	r _{s min}		s ¹	Dynamic C	Static C ₀	Oil RPM		Grease RPM
120	120	165	45	135	1.1	3.5	NA4924	177	407	3100	2000	0.1193	3.040
	4.7244	6.4961	1.772	5.3150	0.043	0.138		39800	91500				
130	130	165	35	145	1.1	1.0	NA4826	112	323	2900	1900	0.1258	1.990
	5.1181	6.4961	1.378	5.7087	0.043	0.039		25200	72600				
130	130	180	45	150	1.5	3.0	NA4926	201	495	2800	1800	0.1314	4.140
	5.1181	7.0866	1.772	5.9055	0.059	0.118		45200	111000				
140	140	175	35	155	1.1	1.0	NA4828	116	346	2700	1700	0.1320	2.120
	5.5118	6.8898	1.378	6.1024	0.043	0.039		26100	77800				
140	140	190	50	160	1.5	3.0	NA4928	214	549	2600	1700	0.1389	4.410
	5.5118	7.4803	1.969	6.2992	0.059	0.118		48100	123000				
150	150	190	40	165	1.1	2.0	NA4830	142	402	2500	1600	0.1367	2.700
	5.9055	7.4803	1.575	6.4961	0.043	0.079		31900	90400				
160	160	200	40	175	1.1	2.0	NA4832	146	425	2400	1500	0.1425	3.150
	6.2992	7.8740	1.575	6.8898	0.043	0.079		32800	95500				

⁽¹⁾ Max. axial displacement

**NEEDLE ROLLER BEARINGS
WITHOUT INNER RINGS** — *continued*
METRIC SERIES

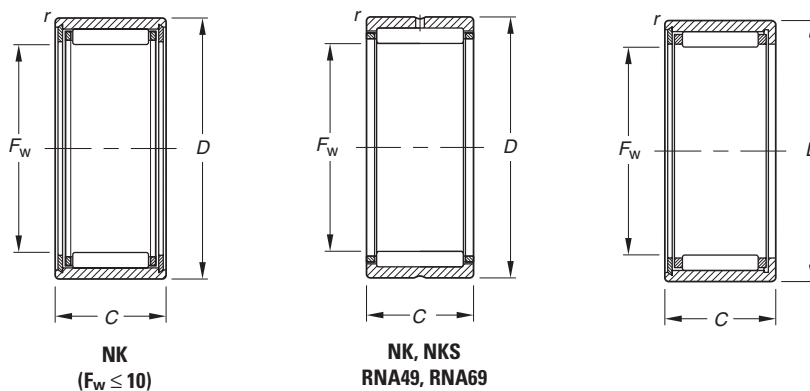

Shaft Diameter	Dimensions mm/in.				Bearing Designation	Load Ratings kN/lbf.		Limiting Speeds		Approx. Wt. kg/lbs.	
	F _w	D	C	r _{s min}		Dynamic	Static	Oil	Grease		
mm	F _w	D	C	r _{s min}		C	C ₀	RPM		C _g	
5	5	10	10	0.2	NK5/10TN	2.18	1.71	47000	31000	0.0095	0.004
	0.1969	0.3937	0.394	0.006		490	384				
5	5	10	12	0.2	NK5/12TN	3.04	2.63	47000	31000	0.0106	0.004
	0.1969	0.3937	0.472	0.006		683	591				
6	6	12	10	0.2	NK6/10	3.19	2.90	44000	29000	0.0116	0.005
	0.2362	0.4724	0.394	0.006		717	652				
6	6	12	12	0.2	NK6/12TN	3.07	2.74	44000	29000	0.0115	0.006
	0.2362	0.4724	0.472	0.006		690	616				
7	7	14	10	0.3	NK7/10TN	2.74	2.44	42000	28000	0.0118	0.007
	0.2756	0.5512	0.394	0.012		616	549				
7	7	14	12	0.3	NK7/12TN	3.40	3.22	42000	28000	0.0127	0.009
	0.2756	0.5512	0.472	0.012		764	724				
8	8	15	12	0.3	NK8/12	4.57	4.89	41000	26000	0.0148	0.011
	0.3150	0.5906	0.472	0.012		1030	1 100				
8	8	15	12	0.3	NK8/12ASR1	4.57	4.89	41000	26000	0.0148	0.011
	0.3150	0.5906	0.472	0.012		1030	1100				
8	8	15	16	0.3	NK8/16	5.22	5.78	41000	26000	0.0154	0.013
	0.3150	0.5906	0.630	0.012		1170	1300				
9	9	16	12	0.3	NK9/12	4.27	4.60	40000	26000	0.0153	0.012
	0.3543	0.6299	0.472	0.012		960	1030				
9	9	16	16	0.3	NK9/16	5.57	6.47	40000	26000	0.0170	0.015
	0.3543	0.6299	0.630	0.012		1250	1450				
10	10	17	12	0.3	NK10/12	5.40	6.43	39000	25000	0.0174	0.013
	0.3937	0.6693	0.472	0.012		1210	1450				
10	10	17	16	0.3	NK10/16TN	5.30	6.27	39000	25000	0.0173	0.015
	0.3937	0.6693	0.630	0.012		1190	1410				
12	12	19	12	0.3	NK12/12	6.86	7.60	30000	19000	0.0195	0.013
	0.4724	0.7480	0.472	0.012		1540	1710				
12	12	19	12	0.3	NK12/16	6.78	9.03	37000	24000	0.0204	0.018
	0.4724	0.7480	0.472	0.012		1520	2030				
14	14	22	13	0.3	RNA4900	9.39	10.3	24000	16000	0.0211	0.018
	0.5512	0.8661	0.512	0.012		2110	2320				
14	14	22	16	0.3	NK14/16	12.4	14.8	24000	16000	0.0231	0.023
	0.5512	0.8661	0.630	0.012		2790	3330				
14	14	22	20	0.3	NK14/20	14.7	18.4	24000	16000	0.0244	0.028
	0.5512	0.8661	0.787	0.012		3300	4140				
15	15	23	16	0.3	NK15/16	12.4	15.0	24000	15000	0.0238	0.024
	0.5906	0.9055	0.630	0.012		2790	3370				
15	15	23	20	0.3	NK15/20	14.7	18.6	24000	15000	0.0252	0.031
	0.5906	0.9055	0.787	0.012		3300	4180				
16	16	24	13	0.3	RNA4901	10.5	12.3	28000	18000	0.0233	0.020
	0.6299	0.9449	0.512	0.012		2360	2770				
16	16	24	16	0.3	NK16/16	15.4	20.2	28000	18000	0.0250	0.025
	0.6299	0.9449	0.630	0.012		3460	4540				

(1) Max. axial displacement

Continued on next page.



NEEDLE ROLLER BEARINGS

NEEDLE ROLLER BEARINGS WITHOUT INNER RINGS — *continued*

METRIC SERIES

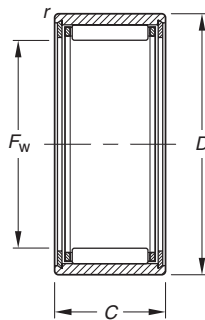

NK
($F_w \leq 10$)

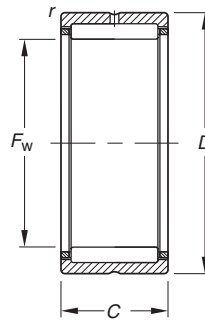

NK, NKS
RNA49, RNA69

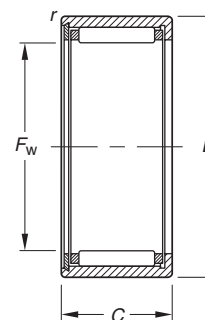

NKTN

Shaft Diameter	Dimensions mm/in.				Bearing Designation	Load Ratings kN/lbf.		Limiting Speeds		Approx. Wt. kg/lbs.	
	F_w	D	C	r_s min		C	C_0	Oil	Grease		
mm							RPM		C_g		
16	16	24	20	0.3	NK16/20	16.1	21.3	28000	18000	0.0264	0.036
	0.6299	0.9449	0.787	0.012		3620	4790				
16	16	24	22	0.3	RNA6901	16.1	21.3	28000	18000	0.0267	0.036
	0.6299	0.9449	0.866	0.012		3620	4790				
17	17	25	16	0.3	NK17/16	13.6	17.5	27000	17000	0.0261	0.027
	0.6693	0.9843	0.630	0.012		3060	3930				
17	17	25	20	0.3	NK17/20	15.4	20.4	27000	17000	0.0271	0.034
	0.6693	0.9843	0.787	0.012		3460	4590				
18	18	26	16	0.3	NK18/16	13.6	17.7	25000	16000	0.0268	0.028
	0.7087	1.0236	0.630	0.012		3060	3980				
18	18	26	20	0.3	NK18/20	16.1	22.0	25000	16000	0.0283	0.035
	0.7087	1.0236	0.787	0.012		3620	4950				
19	19	27	16	0.3	NK19/16	14.1	19.0	24000	15000	0.0279	0.029
	0.7480	1.0630	0.630	0.012		3170	4270				
19	19	27	20	0.3	NK19/20	18.8	23.6	24000	15000	0.0295	0.037
	0.7480	1.0630	0.787	0.012		4230	5310				
19	19	30	16	0.3	NKS18	15.9	16.2	26000	17000	0.0255	0.045
	0.7480	1.1811	0.630	0.012		3570	3640				
20	20	28	13	0.3	RNA4902	11.8	15.3	22000	14000	0.0270	0.023
	0.7874	1.1024	0.512	0.012		2650	3440				
20	20	28	16	0.3	NK20/16	14.1	19.1	22000	14000	0.0285	0.030
	0.7874	1.1024	0.630	0.012		3170	4290				
20	20	28	20	0.3	NK20/20	17.5	25.3	22000	14000	0.0306	0.038
	0.7874	1.1024	0.787	0.012		3930	5690				
20	20	28	23	0.3	RNA6902	18.4	26.9	22000	14000	0.0311	0.042
	0.7874	1.1024	0.906	0.012		4140	6050				
20	20	32	20	0.6	NKS20	24.4	26.7	24000	15000	0.0290	0.058
	0.7874	1.2598	0.787	0.024		5490	6000				
21	21	29	16	0.3	NK21/16	15.3	21.6	21000	14000	0.0301	0.032
	0.8268	1.1417	0.630	0.012		3440	4860				
21	21	29	20	0.3	NK21/20	18.1	26.9	21000	14000	0.0317	0.040
	0.8268	1.1417	0.787	0.012		4070	6050				
22	22	30	13	0.3	RNA4903	12.2	16.4	20000	13000	0.0286	0.025
	0.8661	1.1811	0.512	0.012		2740	3690				
22	22	30	16	0.3	NK22/16	15.2	21.7	20000	13000	0.0307	0.033
	0.8661	1.1811	0.630	0.012		3420	4880				
22	22	30	20	0.3	NK22/20	18.0	27.0	20000	13000	0.0324	0.041
	0.8661	1.1811	0.787	0.012		4050	6070				
22	22	30	23	0.3	RNA6903	19.8	30.6	20000	13000	0.0334	0.056
	0.8661	1.1811	0.906	0.012		4450	6880				
22	22	35	20	0.6	NKS22	22.9	27.1	21000	14000	0.0310	0.069
	0.8661	1.3780	0.787	0.024		5150	6090				
24	24	32	16	0.3	NK24/16	16.2	24.3	18000	12000	0.0328	0.035
	0.9449	1.2598	0.630	0.012		3640	5460				

(1) Max. axial displacement

Continued on next page.

Shaft Diameter	Dimensions mm/in.				Bearing Designation	Load Ratings kN/lbf.		Limiting Speeds		Approx. Wt. kg/lbs.	
	F _w	D	C	r _s min		C	C ₀	Oil	Grease		
mm							RPM		C _g		
25	24 0.9449	32 1.2598	20 0.787	0.3 0.012	NK24/20	19.3 4340	30.3 6810	18000	12000	0.0346	0.045 0.099
	24 0.9449	37 1.4567	20 0.787	0.6 0.024	NKS24	29.1 6540	32.8 7370	20000	13000	0.0325	0.073 0.161
	25 0.9843	33 1.2992	16 0.630	0.3 0.012	NK25/16	16.1 3620	24.4 5490	17000	11000	0.0334	0.037 0.082
	25 0.9843	33 1.2992	20 0.787	0.3 0.012	NK25/20	19.1 4290	30.4 6830	17000	11000	0.0353	0.047 0.104
	25 0.9843	37 1.4567	17 0.669	0.3 0.012	RNA4904	21.3 4790	25.5 5730	18000	12000	0.0318	0.061 0.134
	25 0.9843	37 1.4567	30 1.181	0.3 0.012	RNA6904	36.6 8230	51.0 11500	18000	12000	0.0378	0.091 0.201
26	25 0.9843	38 1.4961	20 0.787	0.6 0.024	NKS25	29.1 6540	33.0 7420	19000	12000	0.0331	0.076 0.168
	26 1.0236	34 1.3386	16 0.630	0.3 0.012	NK26/16	16.6 3730	25.7 5780	17000	11000	0.0344	0.039 0.086
	26 1.0236	34 1.3386	20 0.787	0.3 0.012	NK26/20	19.7 4430	32.0 7190	17000	11000	0.0363	0.048 0.106
	28 1.1024	37 1.4567	20 0.787	0.3 0.012	NK28/20	22.6 5080	34.4 7730	16000	10000	0.0373	0.057 0.126
	28 1.1024	37 1.4567	30 1.181	0.3 0.012	NK28/30	29.0 6520	53.8 12100	16000	10000	0.0427	0.088 0.194
	28 1.1024	39 1.5354	17 0.669	0.3 0.012	RNA49/22	23.3 5240	29.6 6650	16000	10000	0.0346	0.059 0.130
28	28 1.1024	39 1.5354	30 1.181	0.3 0.012	RNA69/22	30.6 6880	50.7 11400	16000	10000	0.0487	0.107 0.236
	28 1.1024	42 1.6535	20 0.787	0.6 0.024	NKS28	30.3 6810	38.4 8630	16000	11000	0.0364	0.094 0.207
	29 1.1417	38 1.4961	20 0.787	0.3 0.012	NK29/20	23.4 5260	36.4 8180	15000	9800	0.0383	0.059 0.130
	29 1.1417	38 1.4961	30 1.181	0.3 0.012	NK29/30	29.8 6700	56.4 12700	15000	9700	0.0438	0.090 0.198
	30 1.1811	40 1.5748	20 0.787	0.3 0.012	NK30/20	24.2 5440	38.3 8610	15000	9500	0.0394	0.071 0.157
	30 1.1811	40 1.5748	30 1.181	0.3 0.012	NK30/30	34.7 7800	61.0 13700	15000	9500	0.0442	0.107 0.236
30	30 1.1811	42 1.6535	17 0.669	0.3 0.012	RNA4905	24.3 5460	31.7 7130	15000	9700	0.0362	0.071 0.157
	30 1.1811	42 1.6535	30 1.181	0.3 0.012	RNA6905	39.7 8920	59.6 13400	15000	9700	0.0424	0.127 0.280
	30 1.1811	45 1.7717	20 0.787	0.6 0.024	NKS30	34.3 7710	42.8 9620	15000	9900	0.0380	0.114 0.251
	32 1.2598	42 1.6535	20 0.787	0.3 0.012	NK32/20	24.8 5580	40.4 9080	14000	8800	0.0411	0.074 0.163
	32 1.2598	42 1.6535	30 1.181	0.3 0.012	NK32/30	35.6 8000	64.3 14500	14000	8800	0.0461	0.112 0.247
	32 1.2598	45 1.7717	17 0.669	0.3 0.012	RNA49/28	25.1 5640	33.8 7600	14000	9000	0.0378	0.080 0.176
32	32 1.2598	45 1.7717	30 1.181	0.3 0.012	RNA69/28	43.2 9710	62.5 14100	14000	9100	0.0612	0.140 0.309
	32 1.2598	47 1.8504	22 0.866	0.6 0.024	NKS32	36.0 8090	46.2 10400	14000	9200	0.0398	0.120 0.265
	35 1.3780	45 1.7717	20 0.787	0.3 0.012	NK35/20	26.1 5870	44.4 9980	12000	8000	0.0437	0.081 0.179
	35 1.3780	45 1.7717	30 1.181	0.3 0.012	NK35/30	37.4 8410	70.6 15900	12000	8000	0.0491	0.122 0.269
	35 1.3780	47 1.8504	18 0.709	0.3 0.012	RNA4906	25.9 5820	36.0 8090	13000	8200	0.0399	0.081 0.179

(1) Max. axial displacement

Continued on next page.



NEEDLE ROLLER BEARINGS

NEEDLE ROLLER BEARINGS WITHOUT INNER RINGS — *continued* METRIC SERIES

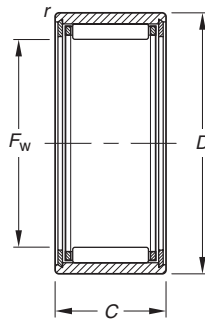

NK
($F_w \leq 10$)

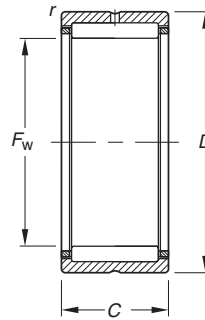

NK, NKS
RNA49, RNA69

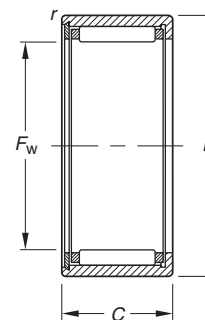

NKTN

Shaft Diameter	Dimensions mm/in.				Bearing Designation	Load Ratings kN/lbf.		Limiting Speeds		Approx. Wt. kg/lbs.	
	F_w	D	C	r_s min		Dynamic	Static	Oil	Grease		
mm	F_w	D	C	r_s min		C	C_0	RPM		C_g	
	35	47	30	0.3	RNA6906	42.6	68.2	13000	8200	0.0467	0.148
	1.3780	1.8504	1.181	0.012		9580	15300				
	35	50	22	0.6	NKS35	37.5	49.9	13000	8400	0.0421	0.130
	1.3780	1.9685	0.866	0.024		8430	11200				
37	37	47	20	0.3	NK37/20	26.6	46.4	12000	7600	0.0453	0.084
	1.4567	1.8504	0.787	0.012		5980	10400				
	37	47	30	0.3	NK37/30	38.2	73.9	12000	7600	0.0508	0.128
	1.4567	1.8504	1.181	0.012		8590	16600				
	37	52	22	0.6	NKS37	39.0	53.4	12000	7900	0.0438	0.134
	1.4567	2.0472	0.866	0.024		8770	12000				
38	38	48	20	0.3	NK38/20	21.7	40.9	11000	7300	0.0456	0.087
	1.4961	1.8898	0.787	0.012		4880	9190				
	38	48	30	0.3	NK38/30	31.9	67.0	11000	7300	0.0516	0.131
	1.4961	1.8898	1.181	0.012		7170	15100				
40	40	50	20	0.3	NK40/20	27.8	50.4	11000	7000	0.0479	0.089
	1.5748	1.9685	0.787	0.012		6250	11300				
	40	50	30	0.3	NK40/30	40.0	80.2	11000	7000	0.0537	0.137
	1.5748	1.9685	1.181	0.012		8990	18000				
	40	52	20	0.6	RNA49/32	32.0	49.3	11000	7100	0.0457	0.100
	1.5748	2.0472	0.787	0.024		7190	11100				
	40	52	36	0.6	RNA69/32	48.6	84.5	11000	7100	0.0620	0.185
	1.5748	2.0472	1.417	0.024		10900	19000				
	40	55	22	0.6	NKS40	40.3	57.0	11000	7200	0.0460	0.140
	1.5748	2.1654	0.866	0.024		9060	12800				
42	42	52	20	0.3	NK42/20	28.3	52.4	10000	6600	0.0494	0.085
	1.6535	2.0472	0.787	0.012		6360	11800				
	42	52	30	0.3	NK42/30	40.7	83.5	10000	6600	0.0554	0.141
	1.6535	2.0472	1.181	0.012		9150	18800				
	42	55	20	0.6	RNA4907	32.8	51.7	10000	6700	0.0454	0.114
	1.6535	2.1654	0.787	0.024		7370	11600				
	42	55	36	0.6	RNA6907	49.9	88.7	10000	6700	0.0641	0.218
	1.6535	2.1654	1.417	0.024		11200	19900				
43	43	53	20	0.3	NK43/20	29.0	54.4	9900	6400	0.0504	0.096
	1.6929	2.0866	0.787	0.012		6520	12200				
	43	53	30	0.3	NK43/30	41.6	86.6	9900	6400	0.0565	0.134
	1.6929	2.0866	1.181	0.012		9350	19500				
	43	58	22	0.6	NKS43	41.6	60.7	10000	6700	0.0481	0.150
	1.6929	2.2835	0.866	0.024		9350	13600				
45	45	55	20	0.3	NK45/20	29.5	56.4	9400	6100	0.0519	0.100
	1.7717	2.1654	0.787	0.012		6630	12700				
	45	55	30	0.3	NK45/30	42.3	89.8	9400	6100	0.0582	0.151
	1.7717	2.1654	1.181	0.012		9510	20200				
	45	60	22	0.6	NKS45	43.0	64.2	9800	6400	0.0498	0.156
	1.7717	2.3622	0.866	0.024		9670	14400				

(1) Max. axial displacement

Continued on next page.

Shaft Diameter	Dimensions mm/in.				Bearing Designation	Load Ratings kN/lbf.		Limiting Speeds		Approx. Wt. kg/lbs.	
	F _w	D	C	r _{s min}		Dynamic C	Static C ₀	Oil RPM	Grease RPM		C _g
47	47	57	20	0.3	NK47/20	30.0	58.5	9000	5900	0.0534	0.104
	1.8504	2.2441	0.787	0.012		6740	13200				
47	47	57	30	0.3	NK47/30	43.0	93.1	9000	5900	0.0599	0.158
	1.8504	2.2441	1.181	0.012		9670	20900				
48	48	62	22	0.6	RNA4908	44.2	67.8	9100	5900	0.0519	0.154
	1.8898	2.4409	0.866	0.024		9940	15200				
48	48	62	40	0.6	RNA6908	70.8	124	9100	5900	0.0717	0.300
	1.8898	2.4409	1.575	0.024		15900	27900				
50	50	62	25	0.3	NK50/25	40.7	79.3	8500	5500	0.0578	0.171
	1.9685	2.4409	0.984	0.012		9150	17800				
50	50	62	35	0.6	NK50/35	55.0	117	8500	5500	0.0636	0.242
	1.9685	2.4409	1.378	0.024		12400	26300				
50	50	65	22	1.0	NKS50	45.5	71.3	8700	5700	0.0535	0.170
	1.9685	2.5591	0.866	0.039		10200	16000				
52	52	68	22	0.6	RNA4909	46.8	74.8	8400	5400	0.0550	0.201
	2.0472	2.6772	0.866	0.024		10500	16800				
52	52	68	40	0.6	RNA6909	74.7	137	8400	5400	0.0759	0.392
	2.0472	2.6772	1.575	0.024		16800	30800				
55	55	68	25	0.6	NK55/25	46.1	87.3	7800	5000	0.0605	0.207
	2.1654	2.6772	0.984	0.024		10400	19600				
55	55	68	35	0.6	NK55/35	62.3	129	7800	5000	0.0667	0.293
	2.1654	2.6772	1.378	0.024		14000	29000				
55	55	72	22	1.0	NKS55	47.9	78.4	7900	5100	0.0571	0.225
	2.1654	2.8346	0.866	0.039		10800	17600				
58	58	72	22	0.6	RNA4910	48.9	82.0	7400	4800	0.0591	0.179
	2.2835	2.8346	0.866	0.024		11000	18400				
58	58	72	40	0.6	RNA6910	75.7	144	7400	4800	0.0806	0.364
	2.2835	2.8346	1.575	0.024		17000	32400				
60	60	72	25	0.6	NK60/25	44.3	94.0	7000	4400	0.0654	0.202
	2.3622	2.8346	0.984	0.024		9960	21100				
60	60	72	35	0.6	NK60/35	59.9	139	7000	4400	0.0721	0.286
	2.3622	2.8346	1.378	0.024		13500	31200				
60	60	80	28	1.1	NKS60	66.9	103	7300	4800	0.0612	0.337
	2.3622	3.1496	1.102	0.043		15000	23200				
63	63	80	25	1.0	RNA4911	62.0	107	6900	4500	0.0645	0.285
	2.4803	3.1496	0.984	0.039		13900	24100				
63	63	80	45	1.0	RNA6911	94.2	172	6900	4500	0.0852	0.540
	2.4803	3.1496	1.772	0.039		21200	38700				
65	65	78	25	0.6	NK65/25	48.2	97.7	6500	4200	0.0671	0.257
	2.5591	3.0709	0.984	0.024		10800	22000				
65	65	78	35	0.6	NK65/35	65.2	144	6500	4200	0.0739	0.298
	2.5591	3.0709	1.378	0.024		14700	32400				
65	65	85	28	1.1	NKS65	71.0	114	6700	4200	0.0650	0.362
	2.5591	3.3465	1.102	0.043		16000	25600				
68	68	82	25	0.6	NK68/25	49.0	101	6200	4000	0.0691	0.287
	2.6772	3.2283	0.984	0.024		11000	22700				
68	68	82	35	0.6	NK68/35	66.2	149	6200	4000	0.0760	0.350
	2.6772	3.2283	1.378	0.024		14900	33500				
68	68	85	25	1.0	RNA4912	64.8	116	6300	4100	0.0681	0.304
	2.6772	3.3465	0.984	0.039		14600	26100				
68	68	85	45	1.0	RNA6912	99.3	189	6300	4100	0.0901	0.546
	2.6772	3.3465	1.772	0.039		22300	42500				
70	70	85	25	0.6	NK70/25	43.6	87.9	6000	3900	0.0705	0.298
	2.7559	3.3465	0.984	0.024		9800	19800				
70	70	85	35	0.6	NK70/35	62.2	139	6000	3900	0.0757	0.411
	2.7559	3.3465	1.378	0.024		14000	31200				
70	70	90	28	1.1	NKS70	72.6	120	6200	4000	0.0679	0.383
	2.7559	3.5433	1.102	0.043		16300	27000				

(1) Max. axial displacement

Continued on next page.



NEEDLE ROLLER BEARINGS

NEEDLE ROLLER BEARINGS WITHOUT INNER RINGS – *continued*

METRIC SERIES

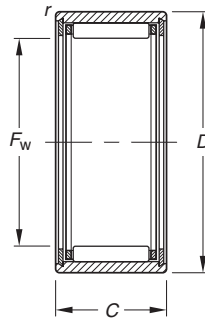

NK
($F_w \leq 10$)

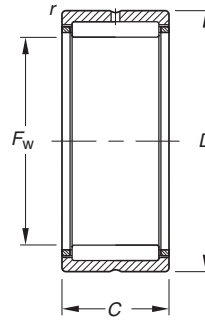

NK, NKS
RNA49, RNA69

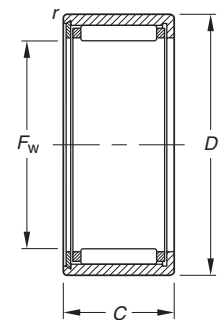

NKTN

Shaft Diameter	Dimensions mm/in.				Bearing Designation	Load Ratings kN/lbf.		Limiting Speeds		Approx. Wt. kg/lbs.	
	F_w	D	C	r_s min		Dynamic	Static	Oil	Grease		
mm	F_w	D	C	r_s min		C	C_0	RPM		C_g	
72	72	90	25	1.0	RNA4913	66.0	121	5900	3900	0.0705	0.346
	2.8346	3.5433	0.984	0.039		14800	27200				
72	72	90	45	1.0	RNA6913	107	213	5900	3900	0.0952	0.679
	2.8346	3.5433	1.772	0.039		24100	47900				
73	73	90	25	0.6	NK73/25	61.5	119	5800	3800	0.0717	0.320
	2.8740	3.5433	0.984	0.024		13800	26800				
73	73	90	35	0.6	NK73/35	82.5	173	5800	3800	0.0787	0.450
	2.8740	3.5433	1.378	0.024		18500	38900				
75	75	92	25	0.6	NK75/25	43.7	90.2	5600	3600	0.0702	0.364
	2.9528	3.6220	0.984	0.024		9820	20300				
75	75	92	35	0.6	NK75/35	60.9	138	5600	3600	0.0780	0.518
	2.9528	3.6220	1.378	0.024		13700	31000				
75	75	95	28	1.1	NKS75	76.5	132	5800	3700	0.0716	0.413
	2.9528	3.7402	1.102	0.043		17200	29700				
80	80	95	25	1.0	NK80/25	65.0	131	5300	3400	0.0766	0.331
	3.1496	3.7402	0.984	0.039		14600	29400				
80	80	95	35	1.0	NK80/35	79.7	184	5300	3400	0.0846	0.380
	3.1496	3.7402	1.378	0.039		17900	41400				
80	80	100	30	1.0	RNA4914	86.3	157	5400	3500	0.0770	0.502
	3.1496	3.9370	1.181	0.039		19400	35300				
80	80	100	54	1.0	RNA6914	137	286	5400	6500	0.1061	0.946
	3.1496	3.9370	2.126	0.039		30800	64300				
85	85	105	25	1.0	NK85/25	76.4	137	5000	3300	0.0764	0.506
	3.3465	4.1339	0.984	0.039		17200	30800				
85	85	105	30	1.0	RNA4915	92.4	175	5000	3300	0.0812	0.528
	3.3465	4.1339	1.181	0.039		20800	39300				
85	85	105	35	1.0	NK85/35	108	214	5000	3300	0.0854	0.610
	3.3465	4.1339	1.378	0.039		24300	48100				
85	85	105	54	1.0	RNA6915	143	308	5000	3300	0.1110	1.020
	3.3465	4.1339	2.126	0.039		32100	69200				
90	90	110	25	1.0	NK90/25	79.5	147	4700	3100	0.0798	0.450
	3.5433	4.3307	0.984	0.039		17900	33000				
90	90	110	30	1.0	RNA4916	91.5	176	4700	3100	0.0834	0.556
	3.5433	4.3307	1.181	0.039		20600	39600				
90	90	110	35	1.0	NK90/35	113	230	4700	3100	0.0891	0.745
	3.5433	4.3307	1.378	0.039		25400	51700				
90	90	110	54	1.0	RNA6916	126	320	4700	3100	0.1197	1.050
	3.5433	4.3307	2.126	0.039		28300	71900				
95	95	115	26	1.0	NK95/26	49.3	114	4400	2800	0.0829	0.572
	3.7402	4.5276	1.024	0.039		11100	25600				
95	95	115	36	1.0	NK95/36	114	238	4500	2900	0.0921	0.803
	3.7402	4.5276	1.417	0.039		25600	53500				
100	100	120	26	1.0	NK100/26	83.6	163	4200	2800	0.0857	0.530
	3.9370	4.7244	1.024	0.039		18800	36600				

(1) Max. axial displacement

Continued on next page.

Shaft Diameter	Dimensions mm/in.				Bearing Designation	Load Ratings kN/lbf.		Limiting Speeds		Approx. Wt. kg/lbs.	
	F _w	D	C	r _s min		Dynamic	Static	Oil	Grease		
mm						C	C ₀	RPM		C _g	
100	100	120	35	1.1	RNA4917	110	230	4200	2800	0.0935	0.715
	3.9370	4.7244	1.378	0.043		24700	51700				1.576
100	100	120	36	1.0	NK100/36	118	254	4200	2800	0.0958	0.658
	3.9370	4.7244	1.417	0.039		26500	57100				1.451
100	100	120	63	1.1	RNA6917	150	416	4200	2800	0.1340	1.350
	3.9370	4.7244	2.480	0.043		33700	93500				2.976
105	105	125	26	1.0	NK105/26	52.2	127	3900	2600	0.0892	0.595
	4.1339	4.9213	1.024	0.039		11700	28600				1.312
105	105	125	35	1.1	RNA4918	114	245	4000	2600	0.0970	0.746
	4.1339	4.9213	1.378	0.043		25600	55100				1.645
105	105	125	63	1.1	RNA6918	154	437	4000	2600	0.1323	1.500
	4.1339	4.9213	2.480	0.043		34600	98200				3.30
110	110	130	30	1.1	NK110/30	103	220	3800	2500	0.0965	0.660
	4.3307	5.1181	1.181	0.043		23200	49500				1.455
110	110	130	35	1.1	RNA4919	115	253	3800	2500	0.0999	0.777
	4.3307	5.1181	1.378	0.043		25900	56900				1.713
110	110	130	40	1.1	NK110/40	132	132	3800	2500	0.1043	0.900
	4.3307	5.1181	1.575	0.043		29700	29700				1.984
110	110	130	63	1.1	RNA6919	158	458	3800	2500	0.1434	1.470
	4.3307	5.1181	2.480	0.043		35500	103000				3.241
115	115	140	40	1.1	RNA4920	139	296	3700	2400	0.1037	1.220
	4.5276	5.5118	1.575	0.043		31200	66500				2.690
120	120	140	30	1.0	RNA4822	90.3	230	3500	2300	0.1059	0.785
	4.7244	5.5118	1.181	0.039		20300	51700				1.731
125	125	150	40	1.1	RNA4922	147	325	3400	2200	0.1101	1.320
	4.9213	5.9055	1.575	0.043		33000	73100				2.910
130	130	150	30	1.0	RNA4824	94.1	249	3200	2100	0.1121	0.850
	5.1181	5.9055	1.181	0.039		21200	56000				1.874
135	135	165	45	1.1	RNA4924	177	407	3100	2000	0.1193	1.980
	5.3150	6.4961	1.772	0.043		39800	91500				4.365
145	145	165	35	1.0	RNA4826	112	323	2900	1900	0.1258	1.100
	5.7087	6.4961	1.378	0.039		25200	72600				2.425
150	150	180	50	1.5	RNA4926	201	495	2800	1800	0.1314	2.420
	5.9055	7.0866	1.969	0.059		45200	111000				5.335
155	155	175	35	1.1	RNA4828	116	346	2700	1700	0.1320	1.170
	6.1024	6.8898	1.378	0.043		26100	77800				2.579
160	160	190	50	1.5	RNA4928	214	549	2600	1700	0.1389	2.560
	6.2992	7.4803	1.969	0.059		48100	123000				5.644
165	165	190	40	1.1	RNA4830	142	402	2500	1600	0.1367	1.540
	6.4961	7.4803	1.575	0.043		31900	90400				3.395
175	175	200	40	1.1	RNA4832	146	425	2400	1500	0.1425	1.910
	6.8898	7.8740	1.575	0.043		32800	95500				4.211

(1) Max. axial displacement



**SEALED NEEDLE ROLLER BEARINGS
WITH INNER RINGS**

METRIC SERIES

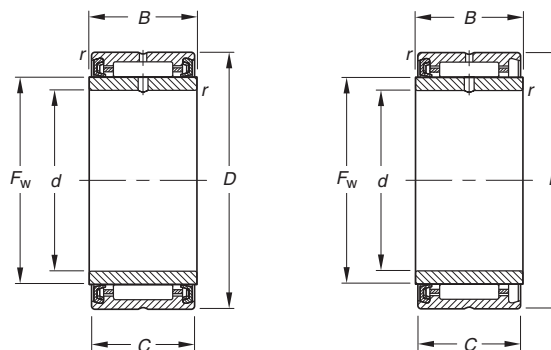

NA49RS

Shaft Diameter	Dimensions mm/in.						Bearing Designation	Load Ratings kN/lbf.		Limiting Speeds		Approx. Wt. kg/lbs.		
	mm	d	D	B	F _w	C		r _s min	Dynamic C	Static C ₀	Oil RPM		Grease RPM	C _g
10	10	10	22	14	13	14	0.3	NA4900RS	7.76	8.06	28000	18000	0.0199	0.027
		0.3937	0.8661	0.551	0.512	0.5512	0.012		1740	1810				0.060
12	12	12	24	14	13	16	0.3	NA4901RS	8.64	9.59	28000	18000	0.0219	0.031
		0.4724	0.9449	0.551	0.512	0.6299	0.012		1940	2160				0.068
15	15	15	28	14	13	20	0.3	NA4902RS	9.77	12.0	22000	14000	0.0254	0.041
		0.5906	1.1024	0.551	0.512	0.7874	0.012		2200	2700				0.090
17	17	17	30	14	13	22	0.3	NA4903RS	10.1	12.8	20000	13000	0.0269	0.044
		0.6693	1.1811	0.551	0.512	0.8661	0.012		2270	2880				0.097
20	20	20	37	18	17	25	0.3	NA4904RS	18.5	21.2	18000	12000	0.0309	0.087
		0.7874	1.4567	0.709	0.669	0.9843	0.012		4160	4770				0.192
25	25	25	42	18	17	30	0.3	NA4905RS	21.0	26.4	15000	9700	0.0346	0.106
		0.9843	1.6535	0.709	0.669	1.1811	0.012		4720	5930				0.234
30	30	30	47	18	17	35	0.3	NA4906RS	22.5	30.0	13000	8200	0.0381	0.119
		1.1811	1.8504	0.709	0.669	1.3780	0.012		5060	6740				0.262
35	35	35	55	21	20	42	0.6	NA4907RS	29.1	44.4	10000	6700	0.0454	0.198
		1.3780	2.1654	0.827	0.787	1.6535	0.024		6540	9980				0.437
40	40	40	62	23	22	48	0.6	NA4908RS	38.6	57.0	9100	5900	0.0497	0.263
		1.5748	2.4409	0.906	0.866	1.8898	0.024		8680	12800				0.580
45	45	45	68	23	22	52	0.6	NA4909.2RS	39.4	60.0	8400	5400	0.0521	0.303
		1.7717	2.6772	0.906	0.866	2.0472	0.024		8860	13500				0.668
50	50	50	72	23	22	58	0.6	NA4910RS	41.2	65.8	7400	4800	0.0559	0.309
		1.9685	2.8346	0.906	0.866	2.2835	0.024		9260	14800				0.681
	50	50	72	23	22	58	0.6	NA4910.2RS	41.2	65.8	7400	4800	0.0559	0.309
		1.9685	2.8346	0.906	0.866	2.2835	0.024		9260	14800				0.681



NEEDLE ROLLER BEARINGS WITHOUT FLANGES WITH INNER RINGS

METRIC SERIES

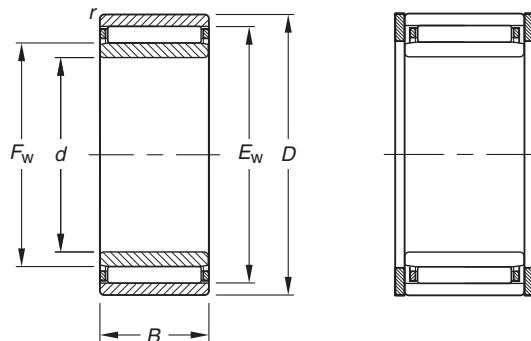

NAO

SNSH

Shaft Dia.	Dimensions mm/in.								Bearing Designation	End Washer Designation	Load Ratings kN/lbf.		Limiting Speeds		Approx. Wt. kg/lbs.
	mm	d	D	B	F _w	E _w	r _{s min}	s ¹			Dynamic C	Static C ₀	Oil RPM	Grease RPM	
6	6	17	10	10	13	0.3	0.5	NAO6X17X10	SNSH10,5X17X0,5	5.40	6.43	39000	25000	0.0174	0.014
	0.2362	0.6693	0.394	0.3937	0.5118	0.012	0.020			1210	1450				0.031
	8	19	10	12	15	0.3	0.5	NAO8X19X10	SNSH12,5X19X0,5	5.85	7.51	37000	24000	0.0195	0.017
	0.3150	0.7480	0.394	0.4724	0.5906	0.012	0.020			1320	1690				0.037
10	10	22	13	14	18	0.3	1.0	NAO10X22X13	SNSH14,5X22X0,5	9.73	12.5	29000	19000	0.0227	0.026
	0.3937	0.8661	0.512	0.5512	0.7087	0.012	0.039			2190	2810				0.057
	10	22	20	14	18	0.3	0.5	NAO10X22X20	SNSH14,5X22X0,5	12.3	16.8	29000	19000	0.0291	0.041
	0.3937	0.8661	0.787	0.5512	0.7087	0.012	0.020			2770	3780				0.090
	10	26	12	14	20	0.3	0.7	NAO10X26X12	SNSH14,5X26X0,5	10.5	10.6	21000	14000	0.0209	0.036
	0.3937	1.0236	0.472	0.5512	0.7874	0.012	0.028			2360	2380				0.079
12	12	24	13	16	20	0.3	1.0	NAO12X24X13	SNSH16,5X24X0,5	10.1	13.5	28000	18000	0.0245	0.030
	0.4724	0.9449	0.512	0.6299	0.7874	0.012	0.039			2270	3030				0.066
	12	24	20	16	20	0.3	0.5	NAO12X24X20	SNSH16,5X24X0,5	13.4	19.5	28000	18000	0.0319	0.046
	0.4724	0.9449	0.787	0.6299	0.7874	0.012	0.020			3010	4380				0.101
	12	28	12	16	22	0.3	0.7	NAO12X28X12	SNSH16,5X28X0,5	11.2	11.9	29000	19000	0.0227	0.041
	0.4724	1.1024	0.472	0.6299	0.8661	0.012	0.028			2520	2680				0.090
15	15	28	13	20	24	0.3	1.0	NAO15X28X13	SNSH20,5X28X0,5	11.5	17.3	22000	14000	0.0287	0.039
	0.5906	1.1024	0.512	0.7874	0.9449	0.012	0.039			2590	3890				0.086
	15	28	26	20	24	0.3	1.0	NAO15X28X26	SNSH20,5X28X0,5	19.8	34.6	22000	14000	0.0405	0.078
	0.5906	1.1024	1.024	0.7874	0.9449	0.012	0.039			4450	7780				0.172
	15	32	12	20	26	0.3	0.7	NAO15X32X12	SNSH20,5X32X0,5	13.0	15.0	23000	15000	0.0264	0.050
	0.5906	1.2598	0.472	0.7874	1.0236	0.012	0.028			2920	3370				0.110
17	17	30	13	22	26	0.3	1.0	NAO17X30X13	SNSH22,5X30X0,5	11.8	18.3	20000	13000	0.0303	0.043
	0.6693	1.1811	0.512	0.8661	1.0236	0.012	0.039			2650	4110				0.095
	17	30	26	22	26	0.3	1.0	NAO17X30X26	SNSH22,5X30X0,5	20.2	36.6	20000	13000	0.0428	0.084
	0.6693	1.1811	1.024	0.8661	1.0236	0.012	0.039			4540	8230				0.185
	17	35	16	22	29	0.3	1.5	NAO17X35X16	SNSH22,5X35X0,5	19.0	23.3	20000	13000	0.0299	0.078
	0.6693	1.3780	0.630	0.8661	1.1417	0.012	0.059			4270	5240				0.172
	17	35	32	22	29	0.3	1.5	NAO17X35X32	SNSH22,5X35X0,5	32.7	46.5	20000	13000	0.0423	0.154
	0.6693	1.3780	1.260	0.8661	1.1417	0.012	0.059			7350	10500				0.340
20	20	35	17	25	30	0.3	1.2	NAO20X35X17	SNSH25,5X35X0,5	18.8	29.8	17000	11000	0.0351	0.073
	0.7874	1.3780	0.669	0.9843	1.1811	0.012	0.047			4230	6700				0.161
	20	35	26	25	30	0.3	1.2	NAO20X35X26	SNSH25,5X35X0,5	25.0	42.8	17000	11000	0.0456	0.112
	0.7874	1.3780	1.024	0.9843	1.1811	0.012	0.047			5620	9620				0.247
	20	37	16	25	32	0.3	1.5	NAO20X37X16	SNSH25,5X37X0,5	19.8	25.3	17000	11000	0.0323	0.080
	0.7874	1.4567	0.630	0.9843	1.2598	0.012	0.059			4450	5690				0.176
	20	37	32	25	32	0.3	1.5	NAO20X37X32	SNSH25,5X37X0,5	34.0	50.7	17000	11000	0.0455	0.162
	0.7874	1.4567	1.260	0.9843	1.2598	0.012	0.059			7640	11400				0.357
25	25	40	17	30	35	0.3	1.2	NAO25X40X17	SNSH30,5X40X0,5	20.2	34.9	14000	9300	0.0394	0.088
	0.9843	1.5748	0.669	1.1811	1.3780	0.012	0.047			4540	7850				0.194
	25	40	26	30	35	0.3	1.2	NAO25X40X26	SNSH30,5X40X0,5	26.8	49.7	14000	9300	0.0512	0.132
	0.9843	1.5748	1.024	1.1811	1.3780	0.012	0.047			6020	11200				0.291
	25	42	16	30	37	0.3	1.5	NAO25X42X16		22.4	31.0	15000	9600	0.0366	0.096
	0.9843	1.6535	0.630	1.1811	1.4567	0.012	0.059			5040	6970				0.212

⁽¹⁾ Max. axial displacement

Continued on next page.

Shaft Dia.	Dimensions mm/in.								Bearing Designation	End Washer Designation	Load Ratings kN/lbf.		Limiting Speeds		C _g	Approx. Wt. kg/lbs.
	d	D	B	F _w	E _w	r _{s min}	s ¹	C			C ₀	Oil	Grease	RPM		
mm																
30	25	42	32	30	37	0.3	1.5	NAO25X42X32		38.2	62.1	15000	9600	0.0517	0.185	
	0.9843	1.6535	1.260	1.1811	1.4567	0.012	0.059			8590	14000					0.408
30	30	45	17	35	40	0.3	1.2	NAO30X45X17		22.1	40.8	12000	7900	0.0440	0.102	
	1.1811	1.7717	0.669	1.3780	1.5748	0.012	0.047			4970	9170					0.225
30	30	45	26	35	40	0.3	1.2	NAO30X45X26		27.7	54.5	12000	7900	0.0561	0.155	
	1.1811	1.7717	1.024	1.3780	1.5748	0.012	0.047			6230	12300					0.342
30	30	47	16	35	42	0.3	1.5	NAO30X47X16	SNSH35,5X47X0,5	24.5	36.8	12000	8100	0.0408	0.106	
	1.1811	1.8504	0.630	1.3780	1.6535	0.012	0.059			5510	8270					0.234
30	30	47	32	35	42	0.3	1.5	NAO30X47X32	SNSH35,5X47X0,5	42.0	73.5	12000	8100	0.0576	0.218	
	1.1811	1.8504	1.260	1.3780	1.6535	0.012	0.059			9440	16500					0.481
35	35	50	17	35	40	0.3	1.2	NAO35X50X17		23.8	47.0	11000	6900	0.0484	0.126	
	1.3780	1.9685	0.669	1.3780	1.5748	0.012	0.047			5350	10600					0.278
35	35	50	34	35	40	0.3	0.7	NAO35X50X34	SNSH40,5X50X0,5	40.9	94.1	11000	6900	0.0682	0.232	
	1.3780	1.9685	1.339	1.3780	1.5748	0.012	0.028			9190	21200					0.511
35	35	55	20	35	43	0.3	1.5	NAO35X55X20	SNSH41X55X1	35.5	56.3	11000	7100	0.0472	0.185	
	1.3780	2.1654	0.787	1.3780	1.6929	0.012	0.059			7980	12700					0.408
35	35	55	40	35	43	0.3	1.7	NAO35X55X40		60.8	113	11000	7100	0.0666	0.370	
	1.3780	2.1654	1.575	1.3780	1.6929	0.012	0.067			13700	25400					0.816
40	40	55	17	45	50	0.3	0.7	NAO40X55X17	SNSH45,5X55X0,5	24.9	51.8	9400	6100	0.0523	0.133	
	1.5748	2.1654	0.669	1.7717	1.9685	0.012	0.028			5600	11600					0.293
40	40	55	34	45	50	0.3	0.7	NAO40X55X34	SNSH45,5X55X0,5	42.7	104	9400	6100	0.0737	0.257	
	1.5748	2.1654	1.339	1.7717	1.9685	0.012	0.028			9600	23400					0.567
40	40	62	20	45	53	0.3	1.5	NAO40X62X20	SNSH46X62X1	36.0	59.5	9600	6200	0.0504	0.215	
	1.5748	2.4409	0.787	1.7717	2.0866	0.012	0.059			8090	13400					0.474
40	40	62	40	45	53	0.3	1.7	NAO40X62X40	SNSH46X62X1	61.7	119	9600	6200	0.0711	0.440	
	1.5748	2.4409	1.575	1.7717	2.0866	0.012	0.067			13900	26800					0.970
45	45	62	20	50	55	0.3	0.7	NAO45X62X20		30.2	68.5	8400	5400	0.0588	0.200	
	1.7717	2.4409	0.787	1.9685	2.1654	0.012	0.028			6790	15400					0.441
45	45	62	40	50	55	0.3	0.5	NAO45X62X40		50.7	137	8400	5400	0.0829	0.386	
	1.7717	2.4409	1.575	1.9685	2.1654	0.012	0.020			11400	30800					0.851
45	45	72	20	55	63	1.0	1.5	NAO45X72X20	SNSH56X72X1	40.3	73.5	7800	5000	0.0580	0.345	
	1.7717	2.8346	0.787	2.1654	2.4803	0.039	0.059			9060	16500					0.761
45	45	72	40	55	63	1.0	1.7	NAO45X72X40	SNSH56X72X1	69.1	147	7800	5000	0.0818	0.680	
	1.7717	2.8346	1.575	2.1654	2.4803	0.039	0.067			15500	33000					1.499
50	50	68	20	55	60	0.3	0.7	NAO50X68X20		30.7	72.4	7600	4900	0.0622	0.230	
	1.9685	2.6772	0.787	2.1654	2.3622	0.012	0.028			6900	16300					0.507
50	50	68	40	55	60	0.3	0.5	NAO50X68X40		52.7	145	7600	4900	0.0878	0.450	
	1.9685	2.6772	1.575	2.1654	2.3622	0.012	0.020			11800	32600					0.992
50	50	78	20	60	68	1.0	1.5	NAO50X78X20	SNSH61X78X1	41.8	79.2	7100	4600	0.0614	0.385	
	1.9685	3.0709	0.787	2.3622	2.6772	0.039	0.059			9400	17800					0.849
50	50	78	40	60	68	1.0	1.7	NAO50X78X40	SNSH61X78X1	71.7	158	7100	4600	0.0867	0.746	
	1.9685	3.0709	1.575	2.3622	2.6772	0.039	0.067			16100	35500					1.645
55	55	85	30	65	73	1.0	2.0	NAO55X85X30	SNSH66X85X1	60.1	129	6500	4200	0.0719	0.690	
	2.1654	3.3465	1.181	2.5591	2.8740	0.039	0.079			13500	29000					1.521
55	55	85	60	65	73	1.0	1.5	NAO55X85X60	SNSH66X85X1	103	259	6500	4200	0.1015	1.320	
	2.1654	3.3465	2.362	2.5591	2.8740	0.039	0.059			23200	58200					2.910
60	60	90	30	70	78	1.0	2.0	NAO60X90X30		62.2	139	6000	3900	0.0757	0.745	
	2.3622	3.5433	1.181	2.7559	3.0709	0.039	0.079			14000	31200					1.642
60	60	90	60	70	78	1.0	1.7	NAO60X90X60		107	277	6000	3900	0.1068	1.405	
	2.3622	3.5433	2.362	2.7559	3.0709	0.039	0.067			24100	62300					3.097
65	65	95	30	75	83	1.0	2.0	NAO65X95X30		60.9	138	5600	3600	0.0780	0.770	
	2.5591	3.7402	1.181	2.9528	3.2677	0.039	0.079			13700	31000					1.698
65	65	95	60	75	83	1.0	1.7	NAO65X95X60		116	277	5600	3600	0.1101	1.500	
	2.5591	3.7402	2.362	2.9528	3.2677	0.039	0.067			26100	62300					3.307
70	70	100	30	80	88	1.0	2.0	NAO70X100X30		67.5	161	5200	3400	0.0835	0.850	
	2.7559	3.9370	1.181	3.1496	3.4646	0.039	0.079			15200	36200					1.874
70	70	100	60	80	88	1.0	1.7	NAO70X100X60		116	322	5200	3400	0.1178	1.600	
	2.7559	3.9370	2.362	3.1496	3.4646	0.039	0.067			26100	72400					3.527

(1) Max. axial displacement

Continued on next page.



NEEDLE ROLLER BEARINGS

NEEDLE ROLLER BEARINGS WITHOUT FLANGES WITH INNER RINGS – *continued*

METRIC SERIES

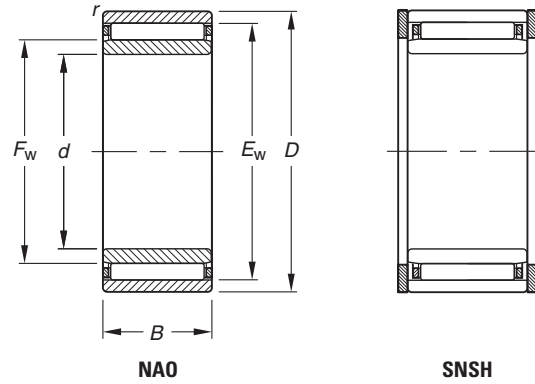

C

Shaft Dia.	Dimensions mm/in.								Bearing Designation	End Washer Designation	Load Ratings kN/lbf.		Limiting Speeds		Approx. Wt. kg/lbs.
	mm	d	D	B	F _w	E _w	r _{s min}	s ¹			Dynamic C	Static C ₀	Oil RPM	Grease RPM	
80	80	110	30	90	98	1.0	2.0	NAO80X110X30		63.6	155	4600	3000	0.0873	0.920
	3.1496	4.3307	1.181	3.5433	3.8583	0.039	0.079			14300	34800				
85	85	115	30	95	103	1.0	2.0	NAO85X115X30		71.0	183	4400	2800	0.0932	0.985
	3.3465	4.5276	1.181	3.7402	4.0551	0.039	0.079			16000	41100				
90	90	120	30	100	108	1.0	2.0	NAO90X120X30		72.4	191	4200	2700	0.0965	1.010
	3.5433	4.7244	1.181	3.9370	4.2520	0.039	0.079			16300	42900				

⁽¹⁾ Max. axial displacement

**NEEDLE ROLLER BEARINGS
WITHOUT FLANGES
WITHOUT INNER RINGS
METRIC SERIES**

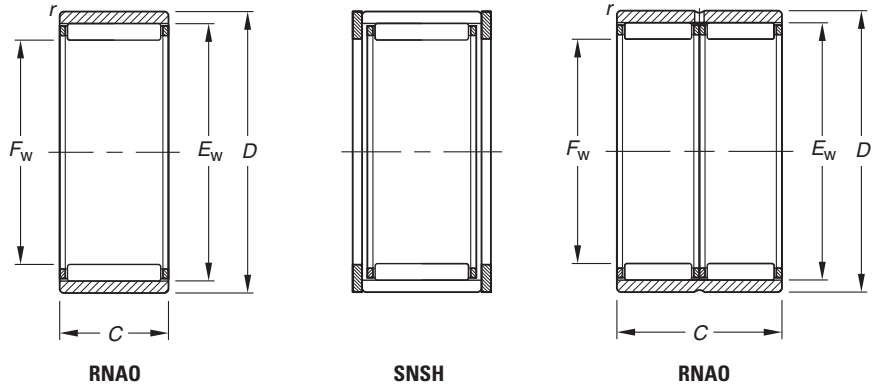

Shaft Dia.	Dimensions mm/in.					Bearing Designation	End Washer Designation	Load Ratings kN/lbf.		Limiting Speeds		Approx. Wt. kg/lbs.	
	F _w	D	C	E _w	r _{s min}			Dynamic	Static	Oil	Grease		C _g
mm	F _w	D	C	E _w	r _{s min}			C	C ₀	RPM	C _g		
6	6	13	8	9	0.3	RNA06X13X8TN		2.47	2.07	44000	29000	0.0107	0.005
	0.2362	0.5118	0.315	0.3543	0.012			560	470				
7	7	14	8	10	0.3	RNA07X14X8TN		2.74	2.44	42000	28000	0.0118	0.007
	0.2756	0.5512	0.315	0.3937	0.012			620	550				
8	8	15	10	11	0.3	RNA08X15X10	SNSH8,5X15X0,5	4.57	4.89	41000	26000	0.0148	0.008
	0.3150	0.5906	0.394	0.4331	0.012			1030	1100				
9	9	16	10	12	0.3	RNA09X16X10		4.27	4.60	40000	26000	0.0153	0.009
	0.3543	0.6299	0.394	0.4724	0.012			960	1030				
10	10	17	10	13	0.3	RNA010X17X10	SNSH10,5X17X0,5	5.40	6.43	39000	25000	0.0174	0.010
	0.3937	0.6693	0.394	0.5118	0.012			1210	1450				
10	10	17	20	13	0.3	RNA010X17X20	SNSH10,5X17X0,5	9.25	12.9	39000	25000	0.0245	0.019
	0.3937	0.6693	0.787	0.5118	0.012			2080	2900				
12	12	19	10	15	0.3	RNA012X19X10	SNSH12,5X19X0,5	5.85	7.51	37000	24000	0.0195	0.012
	0.4724	0.7480	0.394	0.5906	0.012			1320	1690				
14	14	22	13	18	0.3	RNA014X22X13	SNSH14,5X22X0,5	9.73	12.5	29000	19000	0.0227	0.018
	0.5512	0.8661	0.512	0.7087	0.012			2190	2810				
14	14	22	20	18	0.3	RNA014X22X20	SNSH14,5X22X0,5	12.3	16.8	29000	19000	0.0291	0.029
	0.5512	0.8661	0.787	0.7087	0.012			2770	3780				
14	14	26	12	20	0.3	RNA014X26X12	SNSH14,5X26X0,5	10.5	10.6	21000	14000	0.0209	0.029
	0.5512	1.0236	0.472	0.7874	0.012			2360	2380				
15	15	23	13	19	0.3	RNA015X23X13	SNSH15,5X23X0,5	9.66	12.6	28000	18000	0.0235	0.019
	0.5906	0.9055	0.512	0.7480	0.012			2170	2830				
15	15	23	20	19	0.3	RNA015X23X20	SNSH15,5X23X0,5	13.5	19.4	28000	18000	0.0310	0.029
	0.5906	0.9055	0.787	0.7480	0.012			3030	4360				
16	16	24	13	20	0.3	RNA016X24X13	SNSH16,5X24X0,5	10.1	13.5	28000	18000	0.0245	0.022
	0.6299	0.9449	0.512	0.7874	0.012			2270	3030				
16	16	24	20	20	0.3	RNA016X24X20	SNSH16,5X24X0,5	13.4	19.5	28000	18000	0.0319	0.032
	0.6299	0.9449	0.787	0.7874	0.012			3010	4380				
16	16	28	12	22	0.3	RNA016X28X12	SNSH16,5X28X0,5	11.2	11.9	29000	19000	0.0227	0.033
	0.6299	1.1024	0.472	0.8661	0.012			2520	2680				
17	17	25	13	21	0.3	RNA017X25X13	SNSH17,5X25X0,5	10.5	14.5	26000	17000	0.0256	0.022
	0.6693	0.9843	0.512	0.8268	0.012			2360	3260				
17	17	25	20	21	0.3	RNA017X25X20	SNSH17,5X25X0,5	14.7	22.5	26000	17000	0.0333	0.032
	0.6693	0.9843	0.787	0.8268	0.012			3300	5060				
18	18	26	13	22	0.3	RNA018X26X13	SNSH18,5X26X0,5	10.8	15.4	24000	16000	0.0266	0.024
	0.7087	1.0236	0.512	0.8661	0.012			2430	3460				
18	18	26	13	22	0.3	RNA018X26X13ASR1	SNSH18,5X26X0,5	10.8	15.4	24000	16000	0.0266	0.024
	0.7087	1.0236	0.512	0.8661	0.012			2430	3460				
18	18	26	20	22	0.3	RNA018X26X20	SNSH18,5X26X0,5	14.4	22.2	24000	16000	0.0347	0.034
	0.7087	1.0236	0.787	0.8661	0.012			3240	4990				
18	18	30	24	24	0.3	RNA018X30X24		20.2	26.2	25000	17000	0.0343	0.070
	0.7087	1.1811	0.945	0.9449	0.012			4540	5890				
20	20	28	13	24	0.3	RNA020X28X13	SNSH20,5X28X0,5	11.5	17.3	22000	14000	0.0287	0.025
	0.7874	1.1024	0.512	0.9449	0.012			2590	3890				

Continued on next page.



NEEDLE ROLLER BEARINGS

NEEDLE ROLLER BEARINGS WITHOUT FLANGES WITHOUT INNER RINGS

METRIC SERIES

continued

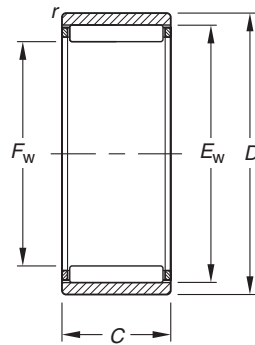

RNAO

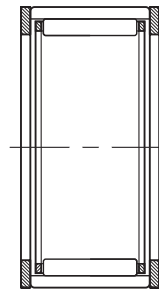

SNSH

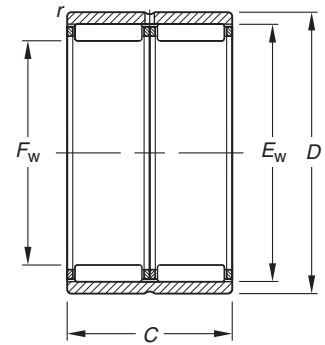

RNAO

Shaft Dia.	Dimensions mm/in.					Bearing Designation	End Washer Designation	Load Ratings kN/lbf.		Limiting Speeds		Approx. Wt. kg/lbs.	
	F _w	D	C	E _w	r _s min			Dynamic	Static	Oil	Grease		
mm	F _w	D	C	E _w	r _s min			C	C ₀	RPM	C _g		
20	20	28	26	24	0.3	RNAO20X28X26	SNSH20,5X28X0,5	19.8	34.6	22000	14000	0.0405	0.050
	0.7874	1.1024	1.024	0.9449	0.012			4450	7780				0.110
	20	32	12	26	0.3	RNAO20X32X12	SNSH20,5X32X0,5	13.0	15.3	23000	15000	0.0264	0.038
20	20	32	24	26	0.3	RNAO20X32X24	SNSH20,5X32X0,5	22.3	30.6	23000	15000	0.0373	0.080
	0.7874	1.2598	0.945	1.0236	0.012			5010	6880				0.176
	22	22	30	13	26	0.3	RNAO22X30X13	SNSH22,5X30X0,5	11.8	18.3	20000	13000	0.0303
22	22	30	26	26	0.3	RNAO22X30X26	SNSH22,5X30X0,5	20.2	36.6	20000	13000	0.0428	0.053
	0.8661	1.1811	1.024	1.0236	0.012			4540	8230				0.117
	22	35	16	29	0.3	RNAO22X35X16	SNSH22,5X35X0,5	19.1	23.3	21000	13000	0.0299	0.059
22	22	35	32	29	0.3	RNAO22X35X32	SNSH22,5X35X0,5	32.7	46.5	21000	13000	0.0423	0.116
	0.8661	1.3780	1.260	1.1417	0.012			7350	10500				0.256
	25	25	35	17	30	0.3	RNAO25X35X17	SNSH25,5X35X0,5	18.8	29.8	17000	11000	0.0351
25	25	35	26	30	0.3	RNAO25X35X26	SNSH25,5X35X0,5	25.0	42.8	17000	11000	0.0456	0.076
	0.9843	1.3780	1.024	1.1811	0.012			5620	9620				0.168
	25	37	16	32	0.3	RNAO25X37X16	SNSH25,5X37X0,5	19.8	25.3	18000	12000	0.0323	0.058
25	25	37	32	32	0.3	RNAO25X37X32	SNSH25,5X37X0,5	19.2	23.6	18000	12000	0.0455	0.118
	0.9843	1.4567	1.260	1.2598	0.012			4320	5310				0.260
	28	28	40	16	35	0.3	RNAO28X40X16	SNSH28,5X40X0,5	20.9	27.9	16000	10000	0.0347
28	28	40	32	35	0.3	RNAO28X40X32	SNSH28,5X40X0,5	35.8	55.9	16000	10000	0.0489	0.128
	1.1024	1.5748	1.260	1.3780	0.012			8050	12600				0.282
	30	30	40	17	35	0.3	RNAO30X40X17	SNSH30,5X40X0,5	20.2	34.6	14000	9300	0.0394
30	30	40	26	35	0.3	RNAO30X40X26	SNSH30,5X40X0,5	26.8	49.7	14000	9300	0.0512	0.088
	1.1811	1.5748	1.024	1.3780	0.012			6020	11200				0.194
	30	42	16	37	0.3	RNAO30X42X16		22.3	31.0	15000	9600	0.0366	0.069
30	30	42	32	37	0.3	RNAO30X42X32		38.2	62.1	15000	9600	0.0517	0.131
	1.1811	1.6535	1.260	1.4567	0.012			8590	14000				0.289
	35	35	45	17	40	0.3	RNAO35X45X17		22.1	40.8	12000	7900	0.0440
35	35	45	26	40	0.3	RNAO35X45X26		27.7	54.5	12000	7900	0.0561	0.091
	1.3780	1.7717	1.024	1.5748	0.012			6230	12300				0.201
	35	47	16	41	0.3	RNAO35X47X16	SNSH35,5X47X0,5	24.5	36.8	12000	8100	0.0404	0.075
35	35	47	32	42	0.3	RNAO35X47X32	SNSH35,5X47X0,5	42.0	73.5	12000	8100	0.0576	0.156
	1.3780	1.8504	1.260	1.6535	0.012			9440	16500				0.344
	40	40	50	17	45	0.3	RNAO40X50X17	SNSH40,5X50X0,5	23.8	47.0	11000	6900	0.0484
40	1.5748	1.9685	0.669	1.7717	0.012			5350	10600				0.190

Continued on next page.

Shaft Dia.	Dimensions mm/in.					Bearing Designation	End Washer Designation	Load Ratings kN/lbf.		Limiting Speeds		C _g	Approx. Wt. kg/lbs.
	F _w	D	C	E _w	r _s min			Dynamic	Static	Oil	Grease		
mm	F _w	D	C	E _w	r _s min			C	C ₀	RPM			
40	40	50	34	45	0.3	RNAO40X50X34	SNSH40,5X50X0,5	40.9	94.1	11000	6900	0.0575	0.152 0.335
	1.5748	1.9685	1.339	1.7717	0.012			9190	21200				
40	40	55	20	48	0.3	RNAO40X55X20	SNSH41X55X1	35.5	56.3	11000	7100	0.0472	0.139 0.306
	1.5748	2.1654	0.787	1.8898	0.012			7980	12700				
40	40	55	40	48	0.3	RNAO40X55X40	SNSH41X55X1	60.8	113	11000	7100	0.0666	0.276 0.608
	1.5748	2.1654	1.575	1.8898	0.012			13700	25400				
45	45	55	17	50	0.3	RNAO45X55X17	SNSH45,5X55X0,5	24.9	51.8	9400	6100	0.0523	0.089 0.196
	1.7717	2.1654	0.669	1.9685	0.012			5600	11600				
45	45	55	34	50	0.3	RNAO45X55X34	SNSH45,5X55X0,5	42.7	104	9400	6100	0.0737	0.168 0.370
	1.7717	2.1654	1.339	1.9685	0.012			9600	23400				
45	45	62	20	53	0.3	RNAO45X62X20	SNSH46X62X1	30.8	68.1	9400	6100	0.0504	0.163 0.359
	1.7717	2.4409	0.787	2.0866	0.012			6920	15300				
45	45	62	40	53	0.3	RNAO45X62X40	SNSH46X62X1	61.7	119	9600	6200	0.0711	0.325 0.717
	1.7717	2.4409	1.575	2.0866	0.012			13900	26800				
50	50	62	20	55	0.3	RNAO50X62X20		30.2	68.5	8400	5400	0.0588	0.142 0.313
	1.9685	2.4409	0.787	2.1654	0.012			6790	15400				
50	50	62	40	55	0.3	RNAO50X62X40		51.7	137	8400	5400	0.0829	0.269 0.593
	1.9685	2.4409	1.575	2.1654	0.012			11600	30800				
50	50	65	20	58	0.3	RNAO50X65X20	SNSH51X65X1	38.8	67.8	8600	5600	0.0545	0.167 0.368
	1.9685	2.5591	0.787	2.2835	0.012			8720	15200				
50	50	65	40	58	0.3	RNAO50X65X40		66.5	136	8600	5600	0.0769	0.342 0.754
	1.9685	2.5591	1.575	2.2835	0.012			14900	30600				
55	55	68	20	60	0.3	RNAO55X68X20		30.7	72.4	7600	4900	0.0622	0.165 0.364
	2.1654	2.6772	0.787	2.3622	0.012			6900	16300				
55	55	68	40	60	0.3	RNAO55X68X40		52.7	145	7600	4900	0.0878	0.320 0.705
	2.1654	2.6772	1.575	2.3622	0.012			11800	32600				
55	55	72	20	63	1.0	RNAO55X72X20	SNSH56X72X1	40.3	73.5	7800	5000	0.0580	0.212 0.467
	2.1654	2.8346	0.787	2.4803	0.039			9060	16500				
55	55	72	40	63	1.0	RNAO55X72X40	SNSH56X72X1	69.1	127	7800	5000	0.0818	0.433 0.955
	2.1654	2.8346	1.575	2.4803	0.039			15500	28600				
60	60	78	20	68	1.0	RNAO60X78X20	SNSH61X78X1	41.8	79.2	7100	4600	0.0614	0.230 0.507
	2.3622	3.0709	0.787	2.6772	0.039			9400	17800				
60	60	78	40	68	1.0	RNAO60X78X40	SNSH61X78X1	71.7	158	7100	4600	0.0867	0.436 0.961
	2.3622	3.0709	1.575	2.6772	0.039			16100	35500				
65	65	85	30	73	1.0	RNAO65X85X30	SNSH66X85X1	60.1	129	6500	4200	0.0719	0.468 1.032
	2.5591	3.3465	1.181	2.8740	0.039			13500	29000				
65	65	85	60	73	1.0	RNAO65X85X60	SNSH66X85X1	103	259	6500	4200	0.1015	0.876 1.931
	2.5591	3.3465	2.362	2.8740	0.039			23200	58200				
70	70	90	30	78	1.0	RNAO70X90X30		62.2	139	6000	3900	0.0757	0.505 1.113
	2.7559	3.5433	1.181	3.0709	0.039			14000	31200				
70	70	90	60	78	1.0	RNAO70X90X60		107	277	6000	3900	0.1068	0.925 2.039
	2.7559	3.5433	2.362	3.0709	0.039			24100	62300				
75	75	95	30	83	1.0	RNAO75X95X30		60.9	138	5600	3600	0.0780	0.510 1.124
	2.9528	3.7402	1.181	3.2677	0.039			13700	31000				
75	75	95	60	83	1.0	RNAO75X95X60		104	277	5600	3600	0.1101	0.980 2.161
	2.9528	3.7402	2.362	3.2677	0.039			23400	62300				
80	80	100	30	88	1.0	RNAO80X100X30		67.5	161	5200	3400	0.0835	0.580 1.279
	3.1496	3.9370	1.181	3.4646	0.039			15200	36200				
80	80	100	60	88	1.0	RNAO80X100X60		116	322	5200	3400	0.1178	1.044 2.30
	3.1496	3.9370	2.362	3.4646	0.039			26100	72400				
85	85	105	30	93	1.0	RNAO85X105X30		69.4	170	4600	3000	0.0870	0.586 1.292
	3.3465	4.1339	1.181	3.6614	0.039			15600	38200				
100	100	120	30	108	1.0	RNAO100X120X30		72.4	191	4200	2700	0.0965	0.660 1.455
	3.9370	4.7244	1.181	4.2520	0.039			16300	42900				





NEEDLE ROLLER BEARINGS FULL COMPLEMENT WITHOUT INNER RINGS METRIC SERIES

- Check for availability.

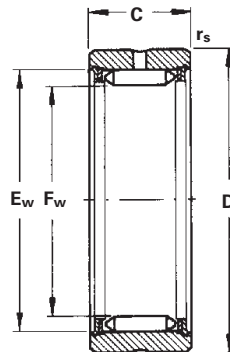

Shaft Diameter	Dimensions mm/in.					Bearing Designation	Load Ratings kN/lbf.		Limiting Speeds		Approx. Wt. kg/lbs.	
	F _w	D	C	E _w	r _s min		Dynamic C	Static C ₀	Oil RPM	Grease RPM		C _g
7.3	7.3 0.2874	16 0.6299	12 0.472	12.3 0.4843	0.35 0.014	RNA 1005	3.95 888	4.45 1000	34000	52000	0.0134	0.010 0.022
9.7	9.7 0.3819	19 0.7480	12 0.472	14.7 0.5787	0.35 0.014	RNA 1007	4.80 1080	5.90 1330	25000	39000	0.0160	0.013 0.029
12.1	12.1 0.4764	22 0.8661	12 0.472	17.1 0.6732	0.35 0.014	RNA 1009	5.60 1260	7.40 1660	20000	31000	0.0184	0.018 0.040
14.4	14.4 0.5669	24 0.9449	12 0.472	19.4 0.7638	0.35 0.014	RNA 1010	6.35 1430	8.90 2000	17000	26000	0.0206	0.020 0.044
17.6	17.6 0.6929	28 1.1024	15 0.591	22.6 0.8898	0.35 0.014	RNA 1012	11.0 2470	16.5 3710	14000	22000	0.0261	0.034 0.075
20.8	20.8 0.8189	32 1.2598	15 0.591	25.8 1.0157	0.65 0.026	RNA 1015	12.4 2790	19.5 4380	12000	18000	0.0292	0.044 0.097
22.1	22.1 0.8701	35 1.3780	22 0.866	28.1 1.1063	0.65 0.026	RNA 2015	23.5 5280	37.5 8430	11000	17000	0.0345	0.082 0.181
23.9	23.9 0.9409	35 1.3780	15 0.591	28.9 1.1378	0.65 0.026	RNA 1017	13.7 3080	22.5 5060	10000	16000	0.0321	0.047 0.104
28.7	28.7 1.1299	42 1.6535	18 0.709	34.7 1.3661	0.65 0.026	RNA 1020	19.3 4340	33.5 7530	8600	13000	0.0374	0.084 0.185
	28.7 1.1299	42 1.6535	22 0.866	34.7 1.3661	0.65 0.026	RNA 2020	28.5 6410	49.0 11000	8600	13000	0.0411	0.104 0.229
33.5	33.5 1.3189	47 1.8504	18 0.709	39.5 1.5551	0.65 0.026	RNA 1025	21.5 4830	39.0 8770	7200	11000	0.0415	0.097 0.214
	33.5 1.3189	47 1.8504	22 0.866	39.5 1.5551	0.65 0.026	RNA 2025	33.0 7420	60.0 13500	7200	11000	0.0457	0.122 0.269
	33.5 1.3189	47 1.8504	30 1.181	39.5 1.5551	0.65 0.026	RNA 22025	52.0 11700	94.0 21100	7200	11000	0.0537	0.170 0.375
38.2	38.2 1.5039	52 2.0472	18 0.709	44.2 1.7402	0.65 0.026	RNA 1030	23.5 5280	44.5 10000	6500	10000	0.0455	0.107 0.236
	38.2 1.5039	52 2.0472	22 0.866	44.2 1.7402	0.65 0.026	RNA 2030	34.5 7760	66.0 14800	6500	10000	0.0501	0.139 0.306
	38.2 1.5039	52 2.0472	30 1.181	44.2 1.7402	0.65 0.026	RNA 22030	57.0 12800	108 24300	6500	10000	0.0588	0.193 0.425
44	44 1.7323	58 2.2835	18 0.709	50.0 1.9685	0.65 0.026	RNA 1035	26.0 5850	51.0 11500	5600	8600	0.0552	0.127 0.280
	44 1.7323	58 2.2835	22 0.866	50.0 1.9685	0.65 0.026	RNA 2035	38.0 8540	75.0 16900	5600	8600	0.0552	0.160 0.353
	44 1.7323	58 2.2835	30 1.181	50.0 1.9685	0.65 0.026	RNA 22035	63.0 14200	124 27900	5600	8600	0.0686	0.225 0.496
	44 1.7323	62 2.4409	30 1.181	51.0 2.0094	0.65 0.026	RNA 3030	64.0 14400	125 28100	5600	8600	0.0607	0.309 0.681
49.7	49.7 1.9567	65 2.5591	18 0.709	55.7 2.1929	0.85 0.033	RNA 1040	28.5 6410	58.0 13000	4900	7600	0.0546	0.160 0.353
	49.7 1.9567	65 2.5591	22 0.866	55.7 2.1929	0.65 0.026	RNA 2040	41.5 9330	85.0 19100	4900	7600	0.0601	0.200 0.441

Continued on next page.

Shaft Diameter	Dimensions mm/in.					Bearing Designation	Load Ratings kN/lbf.		Limiting Speeds		Approx. Wt. kg/lbs.	
	mm	F _w	D	C	E _w		r _s min	Dynamic C	Static C ₀	Oil RPM		Grease RPM
	49.7	65	30	55.7	0.65	RNA 22040	68.0	140	4900	7600	0.0707	0.278
	1.9567	2.5591	1.181	2.1929	0.026		15300	31500				
	49.7	72	36	56.8	0.65	RNA 3035	90.0	183	4900	7600	0.0704	0.545
	1.9567	2.8346	1.417	2.2346	0.026		20200	41100				
55.4	55.4	72	18	61.4	0.85	RNA 1045	30.5	65.0	4500	6900	0.0590	0.193
	2.1811	2.8346	0.709	2.4173	0.033		6860	14600				
	55.4	72	22	61.4	0.85	RNA 2045	45.0	95.0	4500	6900	0.0649	0.242
	2.1811	2.8346	0.866	2.4173	0.033		10100	21400				
	55.4	80	36	62.5	0.85	RNA 3040	97.0	204	4500	6900	0.0759	0.672
	2.1811	3.1496	1.417	2.4591	0.033		21800	45900				
62.1	62.1	80	20	68.1	0.85	RNA 1050	33.0	73.0	4000	6100	0.0639	0.255
	2.4449	3.1496	0.787	2.6811	0.033		7420	16400				
	62.1	80	28	68.1	0.85	RNA 2050	64.0	142	4000	6100	0.0754	0.375
	2.4449	3.1496	1.102	2.6811	0.033		14400	31900				
	62.1	85	38	69.2	0.85	RNA 3045	105	230	4000	6100	0.0823	0.710
	2.4449	3.3465	1.496	2.7228	0.033		23600	51700				
68.8	68.8	85	20	74.8	0.85	RNA 1055	35.5	80.0	3600	5500	0.0687	0.258
	2.7087	3.3465	0.787	2.9449	0.033		7980	18000				
	68.8	85	28	74.8	0.85	RNA 2055	69.0	157	3600	5500	0.0810	0.361
	2.7087	3.3465	1.102	2.9449	0.033		15500	35300				
	68.8	90	38	75.9	0.85	RNA 3050	113	255	3600	5500	0.0885	0.705
	2.7087	3.5433	1.496	2.9866	0.033		25400	57300				
72.6	72.6	90	20	78.6	0.85	RNA 1060	37.0	85.0	3400	5200	0.0714	0.283
	2.8583	3.5433	0.787	3.0945	0.033		8320	19100				
	72.6	90	28	78.6	0.85	RNA 2060	72.0	165	3400	5200	0.0842	0.413
	2.8583	3.5433	1.102	3.0945	0.033		16200	37100				
	72.6	95	38	79.6	0.85	RNA 3055	117	268	3400	5200	0.0811	0.782
	2.8583	3.7402	1.496	3.1339	0.033		26300	60200				
78.3	78.3	95	20	84.3	0.85	RNA 1065	41.5	97.0	3200	4900	0.0751	0.306
	3.0827	3.7402	0.787	3.3189	0.033		9330	21800				
	78.3	95	28	84.3	0.85	RNA 2065	78.0	184	3200	4900	0.0887	0.433
	3.0827	3.7402	1.102	3.3189	0.033		17500	41400				
	78.3	100	38	85.3	0.85	RNA 3060	123.0	290	3200	4900	0.0966	0.810
	3.0827	3.9370	1.496	3.3583	0.033		27700	65200				
83.1	83.1	100	20	89.1	0.85	RNA 1070	43.0	103	2900	4500	0.0784	0.322
	3.2717	3.9370	0.787	3.5079	0.033		9670	23200				
	83.1	100	28	89.1	0.85	RNA 2070	81.0	195	2900	4500	0.0926	0.470
	3.2717	3.9370	1.102	3.5079	0.033		18200	43800				
	83.1	105	38	90.2	0.85	RNA 3065	129	308	2900	4500	0.1012	0.865
	3.2717	4.1339	1.496	3.5496	0.033		29000	69200				
88	88	110	24	95.0	0.85	RNA 1075	64.0	155	2800	4300	0.0864	0.577
	3.4646	4.3307	0.945	3.7402	0.033		14400	34800				
	88	110	32	95.0	0.85	RNA 2075	104	253	2800	4300	0.0983	0.767
	3.4646	4.3307	1.260	3.7402	0.033		23400	56900				
	88	110	38	95.0	0.85	RNA 3070	134	325	2800	4300	0.1050	0.906
	3.4646	4.3307	1.496	3.7402	0.033		30100	73100				
96	96	115	24	103.0	0.85	RNA 1080	68.0	170	2600	4000	0.0918	0.510
	3.7795	4.5276	0.945	4.0551	0.033		15300	38200				
	96	115	32	103.0	0.85	RNA 2080	110	275	2600	4000	0.1045	0.694
	3.7795	4.5276	1.254	4.0551	0.033		24700	61800				
	96	120	38	103.0	0.85	RNA 3075	142	355	2600	4000	0.1117	1.098
	3.7795	4.7244	1.496	4.0551	0.033		31900	79800				
99.5	99.5	120	32	106.5	1.35	RNA 2085	113	285	2500	3800	0.1072	0.787
	3.9173	4.7244	1.260	4.1929	0.053		25400	64100				
	99.5	125	38	106.5	0.85	RNA 3080	145	365	2500	3800	0.1145	1.220
	3.9173	4.9213	1.496	4.1929	0.033		32600	82100				
104.7	104.7	125	32	111.7	1.35	RNA 2090	117	300	2300	3600	0.1113	0.837
	4.1220	4.9213	1.260	4.3976	0.053		26300	67400				

Continued on next page.



NEEDLE ROLLER BEARINGS FULL COMPLEMENT WITHOUT INNER RINGS – *continued*

METRIC SERIES

- Check for availability.

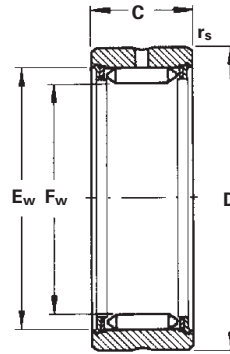

Shaft Diameter	Dimensions mm/in.					Bearing Designation	Load Ratings kN/lbf.		Limiting Speeds		Approx. Wt. kg/lbs.	
	mm	F _w	D	C	E _w		r _{s min}	C	C ₀	Oil Grease RPM		C _g
104.7	104.7	130	38	111.7	1.35	RNA 3085	150	390	2300	3600	0.1189	1.252
	4.1220	5.1181	1.496	4.3976	0.053		33700	87700				
109.1	109.1	130	32	116.1	1.35	RNA 2095	120	315	2300	3500	0.1225	0.882
	4.2953	5.1181	1.260	4.5709	0.053		27000	70800				
109.1	109.1	135	43	116.1	1.35	RNA 3090	185	480	2300	3500	0.1280	1.522
	4.2953	5.3150	1.693	4.5709	0.053		41600	108000				
114.7	114.7	135	32	121.7	1.35	RNA 2100	125	330	2100	3300	0.1188	0.677
	4.5157	5.3150	1.260	4.7913	0.053		28100	74200				
114.7	114.7	140	43	121.7	1.35	RNA 3095	190	505	2100	3300	0.1327	1.551
	4.5157	5.5118	1.693	4.7913	0.053		42700	114000				
119.2	119.2	140	32	126.2	1.35	RNA 2105	129	340	2100	3200	0.1221	0.941
	4.6929	5.5118	1.260	4.9685	0.053		29000	76400				
119.2	119.2	145	43	126.2	1.35	RNA 3100	195	520	2100	3200	0.1364	1.645
	4.6929	5.7087	1.693	4.9685	0.053		43800	117000				
124.5	124.5	145	34	131.5	1.35	RNA 2110	133	360	2000	3000	0.1260	1.015
	4.9016	5.7087	1.339	5.1772	0.053		29900	80900				
124.5	124.5	150	45	131.5	1.35	RNA 3105	203	550	2000	3000	0.1408	1.762
	4.9016	5.9055	1.772	5.1772	0.053		45600	124000				
132.5	132.5	155	34	139.5	1.35	RNA 2115	139	380	1900	2900	0.1318	1.205
	5.2165	6.1024	1.339	5.4921	0.053		31200	85400				
132.5	132.5	160	45	139.5	1.35	RNA 3110	210	580	1900	2900	0.1471	2.037
	5.2165	6.2992	1.772	5.4921	0.053		47200	130000				
137	137	160	34	144.0	1.35	RNA 2120	142	395	1800	2800	0.1350	1.265
	5.3937	6.2992	1.339	5.6693	0.053		31900	88800				
137	137	165	45	144.0	1.35	RNA 3115	215	600	1800	2800	0.1507	2.140
	5.3937	6.4961	1.772	5.6693	0.053		48300	135000				
143.5	143.5	165	34	150.5	1.35	RNA 2125	145	410	1800	2700	0.1403	1.218
	5.6496	6.4961	1.339	5.9268	0.053		32600	92200				
143.5	143.5	170	45	150.5	1.35	RNA 3120	224	630	1800	2700	0.1563	2.107
	5.6496	6.6929	1.772	5.9268	0.053		50400	142000				
148	148	170	34	155.0	1.35	RNA 2130	150	425	1700	2600	0.1435	1.292
	5.8268	6.6929	1.339	6.1039	0.053		33700	95500				
158	158	180	36	165.0	1.35	RNA 2140	157	455	1600	2400	0.1504	1.478
	6.2205	7.0866	1.417	6.4976	0.053		35300	102000				
158	158	190	52	166.0	1.35	RNA 3130	275	790	1600	2400	0.1691	3.285
	6.2205	7.4803	2.047	6.5354	0.053		61800	178000				
170.5	170.5	195	36	177.5	1.35	RNA 2150	165	490	1400	2200	0.1591	1.790
	6.7126	7.6772	1.417	6.9882	0.053		37100	110000				
170.5	170.5	205	52	178.5	1.35	RNA 3140	290	860	1400	2200	0.1787	3.840
	6.7126	8.0709	2.047	7.0276	0.053		65200	193000				
179.3	179.3	205	36	186.3	1.35	RNA 2160	170	515	1400	2100	0.1650	1.970
	7.0591	8.0709	1.417	7.3346	0.053		38200	116000				
179.3	179.3	215	52	187.3	1.35	RNA 3150	300	900	1400	2100	0.1904	4.185
	7.0591	8.4646	2.047	7.3756	0.053		67400	202000				

Continued on next page.



NEEDLE ROLLER BEARINGS FULL COMPLEMENT WITH INNER RINGS METRIC SERIES

- Check for availability.

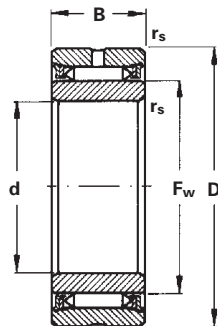

Shaft Diameter	Dimensions mm/in.					Bearing Designation	Load Ratings kN/lbf.		Limiting Speeds		Approx. Wt. kg/lbs.	
	F _w	D	B	E _w	r _s min		Dynamic C	Static C ₀	Oil Grease RPM	C _B		
12	12	28	15	17.6	0.35	NA 1012*	11.0	16.5	14000	22000	0.0261	0.050
	0.4724	1.1024	0.591	0.6929	0.014		2470	3710				
15	15	32	15	20.8	0.65	NA 1015*	12.4	19.5	12000	18000	0.0292	0.044
	0.5906	1.2598	0.591	0.8189	0.026		2790	4380				
15	15	35	22	22.1	0.65	NA 2015	23.5	37.5	11000	17000	0.0345	0.082
	0.5906	1.3780	0.866	0.8701	0.026		5280	8430				
17	17	35	15	23.9	0.65	NA 1017*	13.7	22.5	10000	16000	0.0321	0.047
	0.6693	1.3780	0.591	0.9409	0.026		3080	5060				
20	20	42	18	28.7	0.65	NA 1020	19.3	33.5	8600	13000	0.0374	0.084
	0.7874	1.6535	0.709	1.1299	0.026		4340	7530				
20	20	42	22	28.7	0.65	NA 2020	28.5	49.0	8600	13000	0.0411	0.104
	0.7874	1.6535	0.866	1.1299	0.026		6410	11000				
25	25	47	18	33.5	0.65	NA 1025	21.5	39.0	7200	11000	0.0415	0.097
	0.9843	1.8504	0.709	1.3189	0.026		4830	8770				
25	25	47	22	33.5	0.65	NA 2025	33.0	60.0	7200	11000	0.0457	0.122
	0.9843	1.8504	0.866	1.3189	0.026		7420	13500				
25	25	47	30	33.5	0.65	NA 22025	52.0	94.0	7200	11000	0.0537	0.170
	0.9843	1.8504	1.181	1.3189	0.026		11700	21100				
30	30	52	18	38.2	0.65	NA 1030	23.5	44.5	6500	10000	0.0455	0.107
	1.1811	2.0472	0.709	1.5039	0.026		5280	10000				
30	30	52	22	38.2	0.65	NA 2030	34.5	66.0	6500	10000	0.0501	0.139
	1.1811	2.0472	0.866	1.5039	0.026		7760	14800				
30	30	52	30	38.2	0.65	NA 22030	57.0	108	6500	10000	0.0588	0.193
	1.1811	2.0472	1.181	1.5039	0.026		12800	24300				
30	30	62	30	44.0	0.65	NA 3030	64.0	125	5600	8600	0.0607	0.309
	1.1811	2.4409	1.181	1.7323	0.026		14400	28100				
35	35	58	18	44.0	0.65	NA 1035	26.0	51.0	5600	8600	0.0552	0.127
	1.3780	2.2835	0.709	1.7323	0.026		5850	11500				
35	35	58	22	44.0	0.65	NA 2035	38.0	75.0	5600	8600	0.0552	0.160
	1.3780	2.2835	0.866	1.7323	0.026		8540	16900				
35	35	58	30	44.0	0.65	NA 22035	63.0	124	5600	8600	0.0686	0.225
	1.3780	2.2835	1.181	1.7323	0.026		14200	27900				
35	35	72	36	50.0	0.65	NA 3035	90.0	183	4900	7600	0.0706	0.545
	1.3780	2.8346	1.417	1.9685	0.026		20200	41100				
40	40	65	18	49.7	0.85	NA 1040	28.5	58.0	4900	7600	0.0546	0.160
	1.5748	2.5591	0.709	1.9567	0.033		6410	13000				
40	40	65	22	49.7	0.85	NA 2040	41.5	85.0	4900	7600	0.0601	0.200
	1.5748	2.5591	0.866	1.9567	0.033		9330	19100				
40	40	65	30	49.7	0.85	NA 22040	68.0	140	4900	7600	0.0707	0.278
	1.5748	2.5591	1.181	1.9567	0.033		15300	31500				
40	40	80	36	55.4	0.85	NA 3040	97.0	204	4500	6900	0.0759	0.672
	1.5748	3.1496	1.417	2.1811	0.033		21800	45900				
45	45	72	18	55.4	0.85	NA 1045	30.5	65.0	4500	6900	0.0590	0.193
	1.7717	2.8346	0.709	2.1811	0.033		6860	14600				

* No lubrication holes.

Continued on next page.

Shaft Diameter	Dimensions mm/in.					Bearing Designation	Load Ratings kN/lbf.		Limiting Speeds		Approx. Wt. kg/lbs.	
	mm	F _w	D	B	E _w		r _s min	Dynamic C	Static C ₀	Oil Grease RPM		C _g
	45	72	22	55.4	0.85	NA 2045	45.0	95.0	4500	6900	0.0649	0.242
	1.7717	2.8346	0.866	2.1811	0.033		10100	21400			0.534	
	45	85	38	62.1	0.85	NA 3045	105.0	230	4000	6100	0.0823	0.710
	1.7717	3.3465	1.496	2.4449	0.033		23600	51700			1.565	
50	50	80	20	62.1	0.85	NA 1050	33.0	73.0	4000	6100	0.0639	0.255
	1.9685	3.1496	0.787	2.4449	0.033		7420	16400			0.562	
	50	80	28	62.1	0.85	NA 2050	64.0	142	4000	6100	0.0754	0.375
	1.9685	3.1496	1.102	2.4449	0.033		14400	31900			0.827	
	50	90	38	68.8	0.85	NA 3050	113.0	255	3600	5500	0.0885	0.705
	1.9685	3.5433	1.496	2.7087	0.033		25400	57300			1.554	
55	55	85	20	68.8	0.85	NA 1055	35.5	80.0	3600	5500	0.0687	0.258
	2.1654	3.3465	0.787	2.7087	0.033		7980	18000			0.569	
	55	85	28	68.8	0.85	NA 2055	69.0	157	3600	5500	0.0810	0.361
	2.1654	3.3465	1.102	2.7087	0.033		15500	35300			0.796	
	55	95	38	72.6	0.85	NA 3055	117.0	268	3400	5200	0.0811	0.782
	2.1654	3.7402	1.496	2.8583	0.033		26300	60200			1.724	
60	60	90	20	72.6	0.85	NA 1060	37.0	85.0	3400	5200	0.0714	0.283
	2.3622	3.5433	0.787	2.8583	0.033		8320	19100			0.624	
	60	90	28	72.6	0.85	NA 2060	72.0	165	3400	5200	0.0842	0.413
	2.3622	3.5433	1.102	2.8583	0.033		16200	37100			0.911	
	60	100	38	78.3	0.85	NA 3060	123.0	290	3200	4900	0.0966	0.810
	2.3622	3.9370	1.496	3.0827	0.033		27700	65200			1.786	
65	65	95	28	78.3	0.85	NA 2065	78.0	184	3200	4900	0.0887	0.433
	2.5591	3.7402	1.102	3.0827	0.033		17500	41400			0.955	
	65	105	38	83.1	0.85	NA 3065	129.0	308	2900	4500	0.1012	0.865
	2.5591	4.1339	1.496	3.2717	0.033		29000	69200			1.907	
70	70	100	20	83.1	0.85	NA 1070	43.0	103	2900	4500	0.0784	0.322
	2.7559	3.9370	0.787	3.2717	0.033		9670	23200			0.710	
	70	100	28	83.1	0.85	NA 2070	81.0	195	2900	4500	0.0926	0.470
	2.7559	3.9370	1.102	3.2717	0.033		18200	43800			1.036	
	70	110	38	88.0	0.85	NA 3070	134.0	325	2800	4300	0.1050	0.906
	2.7559	4.3307	1.496	3.4646	0.033		30100	73100			1.997	
75	75	110	32	88.0	0.85	NA 2075	104.0	253	2800	4300	0.0983	0.767
	2.9528	4.3307	1.260	3.4646	0.033		23400	56900			1.691	
	75	120	38	96.0	0.85	NA 3075	142.0	355	2600	4000	0.1117	1.098
	2.9528	4.7244	1.496	3.7795	0.033		31900	79800			2.421	
80	80	115	24	96.0	0.85	NA 1080	68.0	170	2600	4000	0.0918	0.510
	3.1496	4.5276	0.945	3.7795	0.033		15300	38200			1.124	
	80	115	32	96.0	0.85	NA 2080	110.0	275	2600	4000	0.1045	0.694
	3.1496	4.5276	1.254	3.7795	0.033		24700	61800			1.530	
	80	125	38	99.5	0.85	NA 3080	145.0	365	2500	3800	0.1145	1.220
	3.1496	4.9213	1.496	3.9173	0.033		32600	82100			2.690	
85	85	120	32	99.5	1.35	NA 2085	113.0	285	2500	3800	0.1072	0.787
	3.3465	4.7244	1.260	3.9173	0.053		25400	64100			1.735	
	85	130	38	104.7	1.35	NA 3085	150.0	390	2300	3600	0.1189	1.252
	3.3465	5.1181	1.496	4.1220	0.053		33700	87700			2.760	
90	90	125	32	104.7	1.35	NA 2090	117.0	300	2300	3600	0.1113	0.837
	3.5433	4.9213	1.260	4.1220	0.053		26300	67400			1.845	
	90	135	43	109.7	1.35	NA 3090	185.0	480	2300	3500	0.1283	1.522
	3.5433	5.3150	1.693	4.3189	0.053		41600	108000			3.355	
95	95	130	32	109.1	1.35	NA 2095	120.0	315	2300	3500	0.1225	0.882
	3.7402	5.1181	1.260	4.2953	0.053		27000	70800			1.944	
	95	140	43	114.7	1.35	NA 3095	190.0	505	2100	3300	0.1327	1.551
	3.7402	5.5118	1.693	4.5157	0.053		42700	114000			3.419	
100	100	135	32	114.7	1.35	NA 2100	125.0	330	2100	3300	0.1188	0.677
	3.9370	5.3150	1.260	4.5157	0.053		28100	74200			1.493	
	100	145	43	119.2	1.35	NA 3100	195.0	520	2100	3200	0.1364	1.645
	3.9370	5.7087	1.693	4.6929	0.053		43800	117000			3.627	

Continued on next page.



NEEDLE ROLLER BEARINGS FULL COMPLEMENT WITH INNER RINGS – *continued*

METRIC SERIES

- Check for availability.

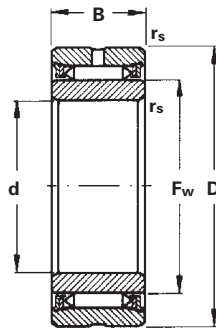

Shaft Diameter	Dimensions mm/in.					Bearing Designation	Load Ratings kN/lbf.		Limiting Speeds		Approx. Wt. kg/lbs.	
	mm	F _w	D	B	E _w		r _{s min}	Dynamic C	Static C ₀	Oil Grease RPM		C _g
105	105	105	140	32	119.2	NA 2105	129.0	340	2100	3200	0.1221	0.941
	4.1339	4.1339	5.5118	1.260	4.6929		29000	76400				
105	105	150	45	124.7	1.35	NA 3105	203.0	550	2000	3000	0.1409	1.762
	4.1339	4.1339	5.9055	1.772	4.9094		45600	124000				
110	110	145	34	124.7	1.35	NA 2110	133.0	360	2000	3000	0.1261	1.015
	4.3307	4.3307	5.7087	1.339	4.9094		29900	80900				
110	110	160	45	132.5	1.35	NA 3110	210.0	580	1900	2900	0.1471	2.037
	4.3307	4.3307	6.2992	1.772	5.2165		47200	130000				
115	115	155	34	132.5	1.35	NA 2115	139.0	380	1900	2900	0.1318	1.205
	4.5276	4.5276	6.1024	1.339	5.2165		31200	85400				
115	115	165	45	137.0	1.35	NA 3115	215.0	600	1800	2800	0.1507	2.140
	4.5276	4.5276	6.4961	1.772	5.3937		48300	135000				
120	120	160	34	137.0	1.35	NA 2120	142.0	395	1800	2800	0.1350	1.265
	4.7244	4.7244	6.2992	1.339	5.3937		31900	88800				
120	120	170	45	143.5	1.35	NA 3120	224.0	630	1800	2700	0.1563	2.107
	4.7244	4.7244	6.6929	1.772	5.6496		50400	142000				
125	125	165	34	143.5	1.35	NA 2125	145.0	410	1800	2700	0.1403	1.218
	4.9213	4.9213	6.4961	1.339	5.6496		32600	92200				
130	130	170	34	148.0	1.35	NA 2130	150.0	425	1700	2600	0.1435	1.292
	5.1181	5.1181	6.6929	1.339	5.8268		33700	95500				
140	140	180	36	158.0	1.35	NA 2140	157.0	455	1600	2400	0.1504	1.478
	5.5118	5.5118	7.0866	1.417	6.2205		35300	102000				
140	140	205	52	170.5	1.35	NA 3140	290.0	860	1400	2200	0.1787	3.840
	5.5118	5.5118	8.0709	2.047	6.7126		65200	193000				
150	150	195	36	170.5	1.35	NA 2150	165.0	490	1400	2200	0.1591	1.790
	5.9055	5.9055	7.6772	1.417	6.7126		37100	110000				
160	160	205	36	179.3	1.35	NA 2160	170.0	515	1400	2100	0.1650	1.970
	6.2992	6.2992	8.0709	1.417	7.0591		38200	116000				
170	170	220	42	193.8	1.35	NA 2170	233.0	720	1300	2000	0.1852	2.570
	6.6929	6.6929	8.6614	1.654	7.6299		52400	162000				
180	180	230	42	202.6	1.35	NA 2180	240.0	750	1200	1900	0.2145	2.835
	7.0866	7.0866	9.0551	1.654	7.9764		54000	169000				
190	190	245	42	216.0	1.35	NA 2190	250.0	800	1200	1800	0.2004	3.210
	7.4803	7.4803	9.6457	1.654	8.5039		56200	180000				
200	200	255	42	224.1	1.35	NA 2200	257.0	830	1100	1700	0.2057	3.560
	7.8740	7.8740	10.0394	1.654	8.8228		57800	187000				



DIMENSIONAL ACCURACY

TOLERANCES AND BEARING CLEARANCE

Metric series cylindrical roller radial bearings are available in various tolerance classes and clearance groups. Single row cylindrical roller bearings are made to normal clearance group C0 although bearings with radial clearance groups C2, C3 and C4 may be obtained on request.

For tolerances of cylindrical roller bearings see page B336. For radial internal clearances of cylindrical roller radial bearings see page B336.

ALIGNMENT

The modified line contact between the cylindrical rollers and raceways of cylindrical roller bearings reduces stress concentration at ends of the rollers and provides some aligning capability. The angular alignment of single row cylindrical roller bearings must not exceed a maximum of 4 angular minutes at a load of $P/C < 0.2$ (P = equivalent dynamic load, kN.) At higher applied loads, or with presence of greater misalignment, consultation with your Timken representative is strongly encouraged.

MOUNTING DIMENSIONS

The bearing inner and outer rings should be mounted against the stepped portion on the shaft and the shoulder of the housing. Under no circumstances should they interfere with the shaft or housing fillets. For this reason the maximum fillet radius $r_{as\ max}$ of the mating component must be no greater than the minimum chamfer dimension of the corresponding cylindrical roller bearing ring corner $r_{s\ min}$.

The shoulder of the mating components must be such that, even with the maximum permissible single chamfer dimension of the corresponding bearing ring, there is an adequate contact surface area. Table 1 lists the maximum fillet radius $r_{as\ max}$ and the minimum shoulder height. At high axial loads the ribs must be supported over half their height.

$$\left(\frac{H + E}{2} \text{ and } \frac{F + J}{2} \right)$$

where from bearing tables:

- F** raceway diameter of the inner ring
- E** raceway diameter of the outer ring
- J** rib diameter of the inner ring
- H** rib diameter of the outer ring

The shaft can be mounted and removed if the mounting dimensions shown in Table 2 on page C135 are observed.

TABLE 1 – ABUTMENT DIMENSIONS AS SPECIFIED IN DIN 5418 FOR METRIC SERIES BEARINGS

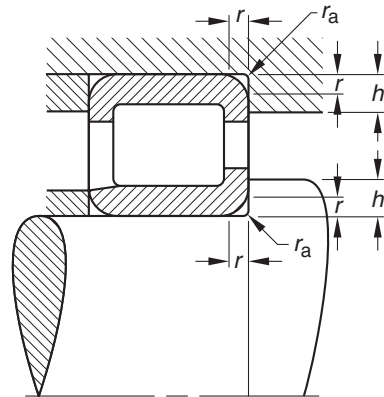

mm	Bearing series			
	10		2..E	3..E
			22..E	23..E
$r_{s\ min}$	$r_{as\ max}$	$h\ min$		
0.3	0.3	1	1.2	
0.6	0.6	1.6	2.1	
1	1	2.3	2.8	
1.1	1	3	3.5	
1.5	1.5	3.5	4.5	
2	2	4.4	5.5	
2.1	2.1	5.1	6	
3	2.5	6.2	7	
4	3	7.3	8.5	
5	4	9	10	
6	5	11.5	13	

See engineering section for shaft tolerances for cylindrical roller bearings with inner rings.

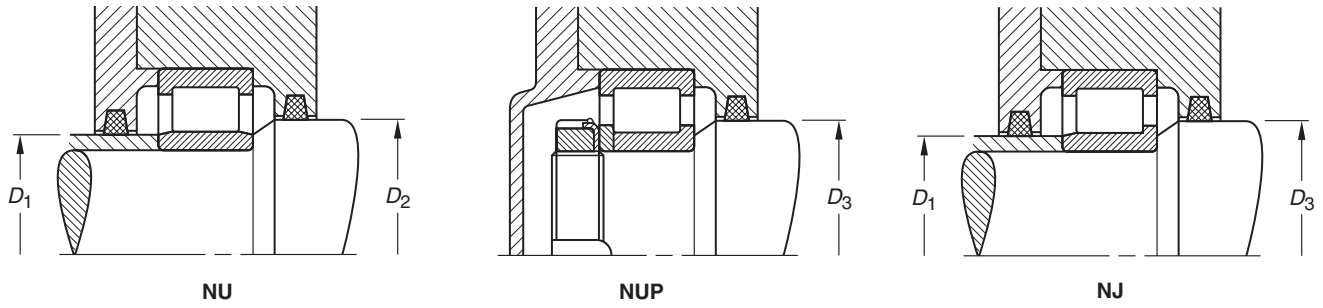

TABLE 2 – MOUNTING DIMENSIONS FOR METRIC SERIES SINGLE-ROW CYLINDRICAL ROLLER BEARINGS

Bore Reference Number	Shaft Diameter mm	Bearing Series 10							
		Max.	Min.	2..E 22..E Max.	Min.	Min.	3..E 23..E Max.	Min.	Min.
		D ₁	D ₂	D ₁	D ₂	D ₃	D ₁	D ₂	D ₃
02	15			20	23	26			
03	17			21	25	27	24	27	30
04	20	25	27	26	29	32	27	30	33
05	25	30	32	31	34	37	33	37	40
06	30	35	38	37	40	44	40	44	48
07	35	41	44	43	46	50	45	48	53
08	40	46	49	49	52	56	51	55	60
09	45	52	54	54	57	61	57	60	66
10	50	57	59	58	62	67	63	67	73
11	55	63	66	65	68	73	69	72	80
12	60	68	71	71	75	80	75	79	86
13	65	73	76	77	81	87	81	85	93
14	70	78	82	82	86	92	87	92	100
15	75	83	87	87	90	96	93	97	106
16	80	90	94	94	97	104	99	105	114





LOAD RATINGS

MAXIMUM CAPACITY BEARINGS

The maximum capacity cylindrical roller radial bearings are designated with a letter E in the suffix. The cylindrical rollers are designed for maximum load carrying capability and are available in bearings of series 2, 22, 3 and 23.

EQUIVALENT DYNAMIC LOADS

For cylindrical roller bearings with purely radial applied load:

$$P = F_r \text{ (kN)}$$

P = Equivalent dynamic load (kN)

F_r = The maximum dynamic radial load that may be applied to a cylindrical roller bearing based on the dynamic load rating C given in the tabular pages. This load should be $\leq C/3$.

If, in addition to the radial load, an axial load F_a acts on the bearing, this axial load is taken into consideration when calculating the life of a bearing (with $F_a \leq F_{az}$; F_{az} is the allowable axial load).

Dimension Series	Load Ratio	Equivalent Dynamic Load
10, 2..E, 3..E	$F_a/F_r \leq 0.11$ $F_a/F_r > 0.11$	$P = F_r$ $P = 0.93 \cdot F_r + 0.69 \cdot F_a$
22..E, 23..E	$F_a/F_r \leq 0.17$ $F_a/F_r > 0.17$	$P = F_r$ $P = 0.93 \cdot F_r + 0.45 \cdot F_a$

ALLOWABLE AXIAL LOAD

Metric series cylindrical roller bearings of NUP, NJ, as well as NU or NJ designs with a thrust collar can transmit axial loads if they are radially loaded at the same time. The allowable axial load ratio F_a/C of 0,1 maximum depends to a great extent on the magnitude of radial load, the operating speed, type of lubricant used, the operating temperature and heat transfer conditions at the bearing location. The heat balance achieved at the bearing location is used as a basis for determination of the allowable axial load.

The nomogram on page C137 should be used to determine the allowable axial load F_{az} based on the following operating conditions:

- The axial load is of constant direction and magnitude
- Radial load ratio $F_r/C \leq 0.2$
- Ratio of axial load to radial load $F_a/F_r < 0.4$
- The temperature of the bearing is 80° C at an ambient temperature of 20° C.
- Lubricating oil is ISO VG 100 using oil bath lubrication or circulating oil.
- As an alternative, the bearing may be lubricated with a grease using the above specified base oil and viscosity. Use of EP additives will be necessary, although considerably shorter relubrication intervals may be expected than with purely radially loaded cylindrical roller radial bearings.

EXAMPLE OF USING THE NOMOGRAM

From the lower part of the nomogram, determine the intersection point of the inner ring bore diameter and the dimension series of the bearing. From the upper part, the allowable axial load ratio F_{az}/C can be found as a function of the operating speed, n.

For a cylindrical roller radial bearing **NU2207E.TVP**

$$C = 63 \text{ kN}; d = 35 \text{ mm}$$

$$n = 2000 \text{ RPM}$$

$$F_r = 10 \text{ kN}$$

From the nomogram:

$$F_{az}/C = 0.06$$

$$\text{Then } F_{az} = 0.06 \cdot 63$$

The calculated allowable axial load F_{az} is 3.78 kN

It should be noted that an axial load as high as that determined by means of the nomogram should not be applied if an oil of rated kinematic viscosity lower than ISO VG 100 is used. Suitable EP additives, which are known for fatigue life improving qualities, may allow for an increase in applied axial load subject to thorough testing.

HIGHER APPLIED AXIAL LOADS

Axial loads greater than those determined by means of the nomogram may be considered, providing they are to be applied intermittently. Also, the bearing should be cooled using circulating oil lubrication and if the operating temperature, due to the internal friction and the higher axial load, exceeds 80° C, a more viscous oil must be used.

EQUIVALENT STATIC LOAD

For cylindrical roller radial bearings with radially applied static loads

$$P_0 = F_r \text{ (kN)}$$

FOR MORE INFORMATION ON CYLINDRICAL ROLLER TYPES NU, NUP AND NJ, SEE THE RADIAL CYLINDRICAL SECTION

NOMOGRAM FOR DETERMINING THE ALLOWABLE AXIAL LOAD F_{AZ}

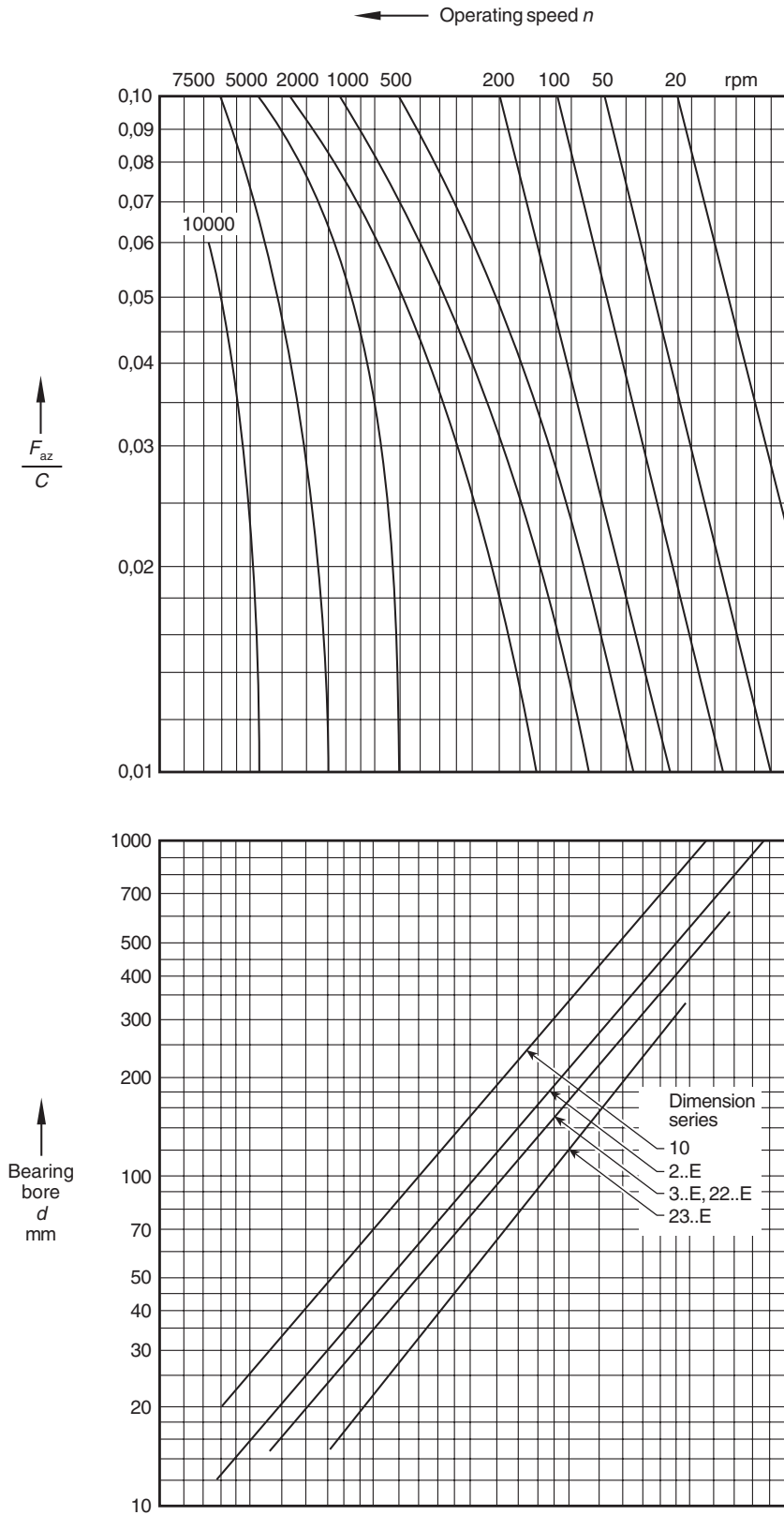



NEEDLE ROLLER BEARINGS –

INCH SERIES

When there is a requirement for a rolling bearing to support very high dynamic, static or even shock loads with a restricted mounting space, the needle roller bearing may be found to give best results.

REFERENCE STANDARDS ARE:

- **ANSI/ABMA Standard 18.2** – Needle Roller Bearings – Radial, Inch Design.
- **ASTM Standard F 2246** – Standard Specification for Bearing, Roller, Needle: Thick Outer Ring with Rollers and Cage.
- **Military Standard MS 51961** – Bearing, Roller, Needle: Thick Outer Ring with Rollers and Cage.

C

IDENTIFICATION

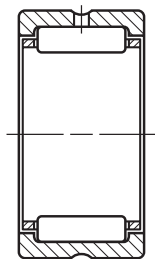

HJ

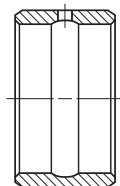

IR

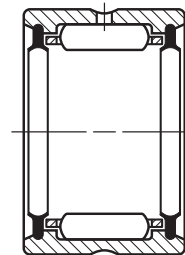

HJ – .2RS

The prefix letters HJ in the needle roller bearing designation denote that the bearing is manufactured to inch nominal dimensions.

Bearings are available with one or two lip contact seals as listed on pages C148-C149. One seal is designated by suffix letters RS. Two seals are designated by .2RS.

Inner rings can be used with HJ Series needle roller bearings for applications where it is impractical to use the shaft as the inner raceway. These inch series inner rings are identified by the prefix letters IR.

Since the entire identification code may not appear on the bearing itself, the manufacturer's parts list or another reliable source should always be consulted when ordering bearings for service or field replacement, to make certain that the correct bearing with the correct lubricant is used.

CONSTRUCTION

The HJ Series needle roller bearing has a one-piece channel-shaped outer ring of bearing quality steel, heat treated to provide maximum load rating. The integral end flanges provide axial location for the needle rollers. The bores of the end flanges serve as piloting surfaces for the cage, locating it to prevent removal of the lubricant film on the raceway.

These bearings have a steel cage which provides inward retention for the needle rollers. The design assures roller stability and minimizes friction between the cage and the needle rollers. The cage has a maximum strength consistent with the inherent high load ratings of needle roller bearings.

The needle rollers are made from high carbon chrome steel, through-hardened, ground and lapped to close tolerance with controlled contour for optimum load distribution.

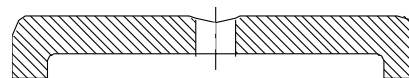

One Piece Channel-Shaped, Outer Ring



DIMENSIONAL ACCURACY, BEARINGS – INCH SERIES

Tolerances for the HJ bearings are given in Tables 1 and 2.

Pages C142-C149 list the nominal outside diameter, width and needle roller complement bore diameter for the HJ bearings.

TABLE 1 – OUTSIDE DIAMETER AND WIDTH TOLERANCES, HJ BEARINGS

D Nominal Outside Diameter				Deviations from Nominal of Single Mean Outside Diameter, $D_{mp}^{(1)}$						of Width, C			
mm		inch		mm		inch		mm		inch			
>	≤	>	≤	high	low	high	low	high	low	high	low		
19.050	50.800	0.7500	2.0000	+0	-0.013	+0	-0.0005	+0	-0.013	+0	-0.005		
50.800	82.550	2.0000	3.2500	+0	-0.015	+0	-0.0006	+0	-0.013	+0	-0.005		
82.550	120.650	3.2500	4.7500	+0	-0.020	+0	-0.0008	+0	-0.013	+0	-0.005		
120.650	184.150	4.7500	7.2500	+0	-0.025	+0	-0.0010	+0	-0.013	+0	-0.005		
184.150	260.350	7.2500	10.2500	+0	-0.030	+0	-0.0012	+0	-0.013	+0	-0.005		
260.350	317.500	10.2500	12.5000	+0	-0.036	+0	-0.0014	+0	-0.013	+0	-0.005		

(1) "Single mean diameter" is defined as the mean diameter in a single radial plane.

TABLE 2 – ROLLER COMPLEMENT BORE TOLERANCE, HJ BEARINGS

F_w Nominal Roller Complement Bore Diameter				Deviations from Nominal of the smallest Single Diameter ⁽¹⁾ of the Roller Complement Bore, $F_w \text{ min.}$			
mm		inch		mm		inch	
>	≤	>	≤	low	high	low	high
12.700	15.875	0.5000	0.6250	+0.020	+0.043	+0.0008	+0.0017
15.875	28.575	0.6250	1.1250	+0.023	+0.046	+0.0009	+0.0018
28.575	41.275	1.1250	1.6250	+0.025	+0.048	+0.0010	+0.0019
41.275	47.625	1.6250	1.8750	+0.025	+0.050	+0.0010	+0.0020
47.625	69.850	1.8750	2.7500	+0.028	+0.053	+0.0011	+0.0021
69.850	76.200	2.7500	3.0000	+0.028	+0.058	+0.0011	+0.0023
76.200	101.600	3.0000	4.0000	+0.030	+0.060	+0.0012	+0.0024
101.600	114.300	4.0000	4.5000	+0.030	+0.066	+0.0012	+0.0026
114.300	152.400	4.5000	6.0000	+0.033	+0.069	+0.0013	+0.0027
152.400	165.120	6.0000	6.5000	+0.033	+0.074	0.0013	+0.0029
165.100	195.850	6.5000	7.7500	+0.036	+0.077	0.0014	+0.0030
196.850	234.950	7.7500	9.2500	+0.036	+0.082	0.0014	+0.0032

(1) "The smallest single diameter of the roller complement bore" is defined as the diameter of the cylinder which, when used as a bearing inner ring, results in zero radial internal clearance in the bearing on at least one diameter.



**DIMENSIONAL ACCURACY, INNER RINGS –
INCH SERIES**

Tolerances for the IR inner rings are given in Table 3 and 4. Pages C150-C153 list the nominal outside diameter, width and bore diameter for the IR series inner rings.

C TABLE 3 – BORE AND WIDTH TOLERANCES, IR INNER RING

d Nominal Outside Diameter				Deviations from Nominal of Single Mean Outside Diameter, $d_{mp}^{(1)}$							
mm		inch		mm				inch			
>	≤	>	≤	high	low	high	low	high	low	high	low
7.938	19.050	0.3125	0.7500	+0	-0.010	+0	-0.0004	+0.25	+0.12	+0.010	+0.005
19.050	50.800	0.7500	2.0000	+0	-0.013	+0	-0.0005	+0.25	+0.12	+0.010	+0.005
50.800	82.550	2.0000	3.2500	+0	-0.015	+0	-0.0006	+0.25	+0.12	+0.010	+0.005
82.550	107.950	3.2500	4.2500	+0	-0.020	+0	-0.0008	+0.25	+0.12	+0.010	+0.005
107.950	120.650	4.2500	4.7500	+0	-0.020	+0	-0.0009	+0.38	+0.25	+0.015	+0.010
120.650	177.800	4.7500	7.0000	+0	-0.025	+0	-0.0010	+0.38	+0.25	+0.015	+0.010
177.800	203.200	7.0000	8.0000	+0	-0.030	+0	-0.00012	+0.38	+0.25	+0.015	+0.010

⁽¹⁾ "Single mean diameter" is defined as the mean diameter in a single radial plane.

TABLE 4 – OUTSIDE DIAMETER TOLERANCE, IR INNER RINGS

F_w Nominal Bore Diameter				Deviations from Nominal of Single Mean Outside Diameter, $F_{mp}^{(1)}$					
mm		inch		mm			inch		
>	≤	>	≤	low	high	low	high	low	high
12.700	15.875	0.5000	0.6250	-0.013	-0.023	-0.0005	-0.0009	-0.0005	-0.0009
15.875	25.400	0.6250	1.0000	-0.018	-0.031	-0.0007	-0.0012	-0.0007	-0.0012
25.400	28.575	1.0000	1.1250	-0.023	-0.036	-0.0009	-0.0014	-0.0009	-0.0014
28.575	34.925	1.1250	1.3750	-0.023	-0.036	-0.0009	-0.0015	-0.0009	-0.0015
34.925	47.625	1.3750	1.8750	-0.025	-0.038	-0.0010	-0.0016	-0.0010	-0.0016
47.625	76.200	1.8750	3.0000	-0.028	-0.040	-0.0011	-0.0018	-0.0011	-0.0018
76.200	95.250	3.0000	3.7500	-0.033	-0.046	-0.0013	-0.0022	-0.0013	-0.0022
95.250	114.300	3.7500	4.5000	-0.038	-0.056	-0.0015	-0.0024	-0.0015	-0.0024
114.300	139.700	4.5000	5.5000	-0.038	-0.061	-0.0015	-0.0025	-0.0015	-0.0025
139.700	165.100	5.5000	6.5000	0.043	-0.063	-0.0017	-0.0027	-0.0017	-0.0027
165.100	209.550	6.5000	8.2500	-0.046	-0.068	-0.0019	-0.0031	-0.0019	-0.0031
209.550	234.950	8.2500	9.2500	-0.051	-0.078	-0.0020	-0.0032	-0.0020	-0.0032

⁽¹⁾ "Single mean diameter" is defined as the mean diameter in a single radial plane.



HJ TYPE

INCH SERIES

- Check for availability.
- Nominal bearing diameters and widths shown.
- Tolerance tables found on page C139.
- Clearance fit suggested for outer ring when housing is stationary relative to load.
- Tight transition fit suggested if housing rotates relative to load.
- See page C141 for further discussion on mounting practices.
- Consult your Timken representative for oscillating applications (e.g., low radial clearance concerns).
- Unmarked end of outer ring should be assembled against housing shoulder to clear maximum allowed housing fillet ($r_{as\ max}^*$).
- Meets Military Standard MS 51961.

Shaft Diameter	Dimensions mm/in.				Bearing Designation	Used With Inner Ring Designation †	Load Ratings kN/lbf.				Approx Wt. kg/lbs.	
	in.	F _w	D	C/B			r _{s min}	C	C ₀	Limiting Speed		
										Grease		Oil
5/8	15.875	28.575	19.050	0.64	HJ-101812	IR-061012	19.3	20.7	20000	30000	0.050	
	0.6250	1.1250	0.750	0.03								4350
3/4	19.050	31.750	19.050	1.02	HJ-122012	IR-081212	20.7	23.3	16000	25000	0.059	
	0.7500	1.2500	0.750	0.04								4650
7/8	19.050	31.750	25.400	1.02	HJ-122016	IR-081216	27.5	33.7	16000	25000	0.077	
	0.7500	1.2500	1.000	0.04								6190
1	22.225	34.925	19.050	1.02	HJ-142212	IR-101412	23	27.9	13000	21000	0.064	
	0.8750	1.3750	0.750	0.04								5180
1 1/8	22.225	34.925	25.400	1.02	HJ-142216	IR-101416	30.7	40.3	13000	21000	0.086	
	0.8750	1.3750	1.000	0.04								6910
1 1/4	25.400	38.100	19.050	1.02	HJ-162412	IR-121612	25.3	32.5	12000	18000	0.073	
	1.0000	1.5000	0.750	0.04								5680
1 1/2	25.400	38.100	25.400	1.02	HJ-162416	IR-121616	33.6	47.2	12000	18000	0.095	
	1.0000	1.5000	1.000	0.04								7560
1 3/8	28.575	41.275	25.400	1.02	HJ-182616	IR-141816	36.3	53.8	10000	16000	0.104	
	1.1250	1.6250	1.000	0.04								8170
1 7/8	28.575	41.275	31.750	1.02	HJ-182620	IR-141820	44.9	70.3	10000	16000	0.132	
	1.1250	1.6250	1.250	0.04								10100
1 3/4	31.750	44.450	25.400	1.02	HJ-202816	IR-162016	37.4	57.4	9100	14000	0.113	
	1.2500	1.7500	1.000	0.04								8410
1 1/2	31.750	44.450	31.750	1.02	HJ-202820	IR-162020	46.3	75.2	9100	14000	0.145	
	1.2500	1.7500	1.250	0.04								10400
1 5/8	34.925	47.625	25.400	1.02	HJ-223016	IR-182216	39.8	64.1	8200	13000	0.127	
	1.3750	1.8750	1.000	0.04								8950
1 7/8	34.925	47.625	31.750	1.02	HJ-223020	IR-182220	49.4	84.1	8200	13000	0.159	
	1.3750	1.8750	1.250	0.04								11100
1 3/2	38.100	52.388	25.400	1.52	HJ-243316	IR-202416	47.6	72.5	7600	12000	0.154	
	1.5000	2.0625	1.000	0.06								10700
1 1/2	38.100	52.388	31.750	1.52	HJ-243320	IR-192420	58.7	95.2	7600	12000	0.195	
	1.5000	2.0625	1.250	0.06								13200
1 5/8	41.275	55.563	25.400	1.52	HJ-263516	IR-212616	48.5	76.5	7000	11000	0.163	
	1.6250	2.1875	1.000	0.06								10900
1 3/4	41.275	55.563	31.750	1.52	HJ-263520	IR-212620	60.1	100.5	7000	11000	0.209	
	1.6250	2.1875	1.250	0.06								13500
1 7/4	44.450	58.738	25.400	1.52	HJ-283716	IR-232816	49.8	81.0	6400	9900	0.177	
	1.7500	2.3125	1.000	0.06								11200
1 1/2	44.450	58.738	31.750	1.52	HJ-283720	IR-222820	61.8	106	6400	9900	0.222	
	1.7500	2.3125	1.250	0.06								13900
1 7/8	47.625	61.913	31.750	1.52	HJ-303920	IR-253020	65.4	117	6000	9200	0.236	
	1.8750	2.4375	1.250	0.06								14700

† See pages C150-C153 for inch series inner rings. Order inner rings separately.

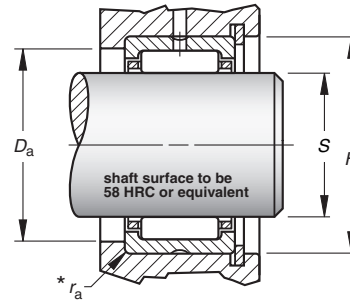
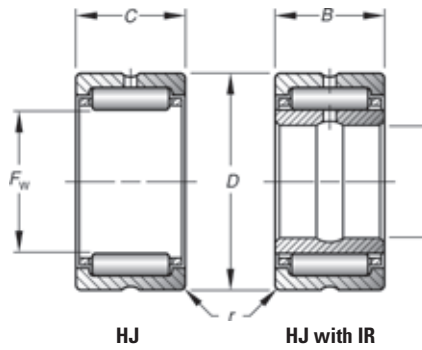

C _g ¹	Mounting Dimensions mm/in.				Bearing Designation	Mounting Dimensions mm/in.				Shoulder Dia. ±.038 ±.015	Shaft Diameter in.
	Clearance Fit					Tight Transition Fit					
	Max.	Min.	Min.	Max.		Max.	Min.	Min.	Max.		
	S		H		S		H		D _a		
0.0252	15.875 0.6250	15.865 0.6246	28.575 1.1250	28.595 1.1258	HJ-101812	15.860 0.6244	15.850 0.6240	28.547 1.1239	28.567 1.1247	23.83 0.938	5/8
0.0279	19.050 0.7500	19.037 0.7495	31.750 1.2500	31.775 1.2510	HJ-122012	19.030 0.7492	19.017 0.7487	31.717 1.2487	31.742 1.2497	26.97 1.062	3/4
0.0305	19.050 0.7500	19.037 0.7495	31.750 1.2500	31.775 1.2510	HJ-122016	19.030 0.7492	19.017 0.7487	31.717 1.2487	31.742 1.2497	26.97 1.062	
0.0310	22.225 0.8750	22.212 0.8745	34.925 1.3750	34.950 1.3760	HJ-142212	22.205 0.8742	22.192 0.8737	34.892 1.3737	34.917 1.3747	30.18 1.188	7/8
0.0340	22.225 0.8750	22.212 0.8745	34.925 1.3750	34.950 1.3760	HJ-142216	22.205 0.8742	22.192 0.8737	34.892 1.3737	34.917 1.3747	30.18 1.188	
0.0340	25.400 1.0000	25.387 0.9995	38.100 1.5000	38.125 1.5010	HJ-162412	25.380 0.9992	25.367 0.9987	38.067 1.4987	38.092 1.4997	33.32 1.312	1
0.0373	25.400 1.0000	25.387 0.9995	38.100 1.5000	38.125 1.5010	HJ-162416	25.380 0.9992	25.367 0.9987	38.067 1.4987	38.092 1.4997	33.32 1.312	
0.0404	28.575 1.1250	28.562 1.1245	41.275 1.6250	41.300 1.6260	HJ-182616	28.555 1.1242	28.542 1.1237	41.242 1.6237	41.267 1.6247	36.53 1.438	1 1/8
0.0433	28.575 1.1250	28.562 1.1245	41.275 1.6250	41.300 1.6260	HJ-182620	28.555 1.1242	28.542 1.1237	41.242 1.6237	41.267 1.6247	36.53 1.438	
0.0430	31.750 1.2500	31.735 1.2494	44.450 1.7500	44.475 1.7510	HJ-202816	31.725 1.2490	31.709 1.2484	44.417 1.7487	44.442 1.7497	39.67 1.562	1 1/4
0.0460	31.750 1.2500	31.735 1.2494	44.450 1.7500	44.475 1.7510	HJ-202820	31.725 1.2490	31.709 1.2484	44.417 1.7487	44.442 1.7497	39.67 1.562	
0.0460	34.925 1.3750	34.910 1.3744	47.625 1.8750	47.650 1.8760	HJ-223016	34.900 1.374	34.884 1.3734	47.592 1.8737	47.617 1.8747	42.88 1.688	1 3/8
0.0492	34.925 1.3750	34.910 1.3744	47.625 1.8750	47.650 1.8760	HJ-223020	34.900 1.3740	34.884 1.3734	47.592 1.8737	47.617 1.8747	42.88 1.688	
0.0480	38.100 1.5000	38.085 1.4994	52.388 2.0625	52.418 2.0637	HJ-243316	38.075 1.4990	38.059 1.4984	52.349 2.0610	52.380 2.0622	47.63 1.875	1 1/2
0.0514	38.100 1.5000	38.085 1.4994	52.388 2.0625	52.418 2.0637	HJ-243320	38.075 1.4990	38.059 1.4984	52.349 2.0610	52.380 2.0622	47.63 1.875	
0.0503	41.275 1.6250	41.260 1.6244	55.563 2.1875	55.593 2.1887	HJ-263516	41.250 1.6240	41.234 1.6234	55.524 2.1860	55.555 2.1872	50.80 2.000	1 5/8
0.0539	41.275 1.6250	41.260 1.6244	55.563 2.1875	55.593 2.1887	HJ-263520	41.250 1.6240	41.234 1.6234	55.524 2.1860	55.555 2.1872	50.80 2.000	
0.0527	44.450 1.7500	44.435 1.7494	58.738 2.3125	58.768 2.3137	HJ-283716	44.425 1.7490	44.409 1.7484	58.699 2.3110	58.730 2.3122	53.98 2.125	1 3/4
0.0564	44.450 1.7500	44.435 1.7494	58.738 2.3125	58.768 2.3137	HJ-283720	44.425 1.7490	44.409 1.7484	58.699 2.3110	58.730 2.3122	53.98 2.125	
0.0595	47.625 1.8750	47.610 1.8744	61.913 2.4375	61.943 2.4387	HJ-303920	47.600 1.8740	47.584 1.8734	61.874 2.4360	61.905 2.4372	57.15 2.250	1 7/8

*r_{as max} is equal to the minimum bearing chamfer (r_{s min}) at unmarked end.

(1) C_g factor for bearing without inner ring

Continued on next page.



HJ TYPE — continued

INCH SERIES

- Check for availability.
- Nominal bearing diameters and widths shown.
- Tolerance tables found on page C139.
- Clearance fit suggested for outer ring when housing is stationary relative to load.
- Tight transition fit suggested if housing rotates relative to load.
- See page C141 for further discussion on mounting practices.
- Consult your Timken representative for oscillating applications (e.g., low radial clearance concerns).
- Unmarked end of outer ring should be assembled against housing shoulder to clear maximum allowed housing fillet ($r_{as\ max}^*$).
- Meets Military Standard MS 51961.

Shaft Diameter	Dimensions mm/in.				Bearing Designation	Used With Inner Ring Designation †	Load Ratings kN/lbf.				Approx. Wt. kg/lbs.	
	in.	F _w	D	C/B			r _{s min}	C	C ₀	Limiting Speed		
										Grease		Oil
2	50.800	65.088	25.400	1.52	HJ-324116	IR-273216	53.8	93.0	5600	8600	0.200	
	2.0000	2.5625	1.000	0.06			12100	20900				0.44
	50.800	65.088	31.750	1.52	HJ-324120	IR-243220 IR-253220 IR-263220 IR-273220	66.7	122	5600	8600	0.249	
	2.0000	2.5625	1.250	0.06			15000	27500				0.55
2 1/4	57.150	76.200	38.100	1.52	HJ-364824	IR-283624	89.9	164	5000	7600	0.458	
	2.2500	3.0000	1.500	0.06			20200	36900				1.01
	57.150	76.200	44.450	1.52	HJ-364828	IR-283628	104	198	5000	7600	0.531	
	2.2500	3.0000	1.750	0.06			23400	44500				1.17
2 1/2	63.500	82.550	38.100	2.03	HJ-405224	IR-314024 IR-324024	97.0	187	4400	6800	0.499	
	2.5000	3.2500	1.500	0.08			21800	42100				1.10
	63.500	82.550	44.450	2.03	HJ-405228	IR-314028 IR-324028	97.0	187	4400	6800	0.499	
	2.5000	3.2500	1.750	0.08			25200	50800				1.29
2 3/4	69.850	88.900	25.400	2.03	HJ-445616	—	67.2	120	4000	6200	0.363	
	2.7500	3.5000	1.000	0.08			15100	27000				0.80
	69.850	88.900	38.100	2.03	HJ-445624	IR-364424	101	203	4000	6200	0.544	
	2.7500	3.5000	1.500	0.08			22700	45700				1.20
	69.850	88.900	44.450	2.03	HJ-445628	IR-354428 IR-364428	117	245	4000	6200	0.635	
	2.7500	3.5000	1.750	0.08			26300	55100				1.40
3	76.200	95.250	38.100	2.03	HJ-486024	IR-404824	107	226	3700	5600	0.585	
	3.0000	3.7500	1.500	0.08			24100	50900				1.29
	76.200	95.250	44.450	2.03	HJ-486028	IR-384828 IR-404828	124	273	3700	5600	0.685	
	3.0000	3.7500	1.750	0.08			27900	61400				1.51
3 1/4	82.550	107.950	44.450	2.03	HJ-526828	IR-445228	162	305	3400	5300	1.016	
	3.2500	4.2500	1.750	0.08			36400	68600				2.24
	82.550	107.950	50.800	2.03	HJ-526832	IR-445232	184	358	3400	5300	1.161	
	3.2500	4.2500	2.000	0.08			41300	80500				2.56
3 1/2	88.900	114.300	50.800	2.03	HJ-567232	IR-475632 IR-485632	187	375	3200	4900	1.238	
	3.5000	4.5000	2.000	0.08			42000	84300				2.73
3 3/4	95.250	120.650	50.800	2.54	HJ-607632	IR-506032 IR-526032	197	405	4540	4375	1.455	
	3.7500	4.7500	2.000	0.10			44200	91000				3.208
4	101.600	127.000	50.800	2.54	HJ-648032	IR-526432 IR-546432 IR-566432	205	436	4230	4625	1.541	
	4.0000	5.0000	2.000	0.10			46000	98000				3.397
4 1/4	107.950	133.350	50.800	2.54	HJ-688432	IR-566832 IR-606832	207	454	3970	4875	1.626	
	4.2500	5.2500	2.000	0.10			46500	102000				3.586
4 1/2	114.300	152.400	57.150	2.54	HJ-729636	IR-607236	286	516	3850	5438	3.035	
	4.5000	6.0000	2.250	0.10			64400	116000				6.691
	114.3000	152.4000	63.500	2.54	HJ-729640	IR-607240	319	596	3850	5438	3.372	
	4.5000	6.0000	2.500	0.10			71700	134000				7.434

† See pages C150-C153 for inch series inner rings. Order inner rings separately.

(1) C₀ factor for bearing without inner ring.

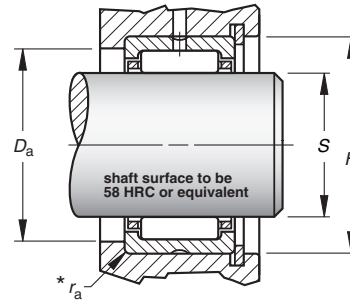
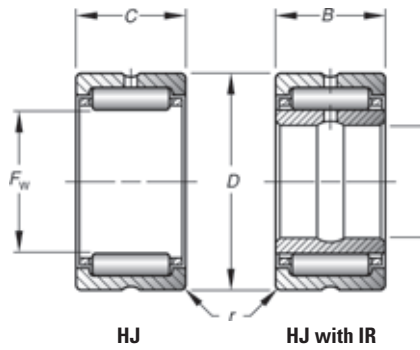

C _g ⁽¹⁾	Mounting Dimensions mm/in.				Bearing Designation	Mounting Dimensions mm/in.				Shoulder Dia. ±.38 ±.015	Shaft Diameter in.
	Clearance Fit					Tight Transition Fit					
	Max.	Min.	Min.	Max.		Max.	Min.	Min.	Max.		
	S	H			S	H			D _a		
0.0578	50.800 2.0000	50.782 1.9993	65.088 2.5625	65.118 2.5637	HJ-324116	50.770 1.9988	50.752 1.9981	65.049 2.5610	65.080 2.5622	60.33 2.375	
0.0618	50.800 2.0000	50.782 1.9993	65.088 2.5625	65.118 2.5637	HJ-324120	50.770 1.9988	50.752 1.9981	65.049 2.5610	65.080 2.5622	60.33 2.375	2
0.0683	57.150 2.2500	57.132 2.2493	76.200 3.0000	76.230 3.0012	HJ-364824	57.120 2.2488	57.102 2.2481	76.162 2.9985	76.192 2.9997	68.28 2.688	2 1/4
0.0715	57.150 2.2500	57.132 2.2493	76.200 3.0000	76.230 3.0012	HJ-364828	57.120 2.2488	57.102 2.2481	76.162 2.9985	76.192 2.9997	68.28 2.688	
0.0739	63.500 2.5000	63.482 2.4993	82.550 3.2500	82.586 3.2514	HJ-405224	63.470 2.4988	63.452 2.4981	82.502 3.2481	82.537 3.2495	74.63 2.938	2 1/2
0.0774	63.500 2.5000	63.482 2.4993	82.550 3.2500	82.586 3.2514	HJ-405228	63.470 2.4988	63.452 2.4981	82.502 3.2481	82.537 3.2495	74.63 2.938	
0.0690	69.850 2.7500	69.832 2.7493	88.900 3.5000	88.936 3.5014	HJ-445616	69.820 2.7488	69.802 2.7481	88.852 3.4981	88.887 3.4995	80.98 3.188	
0.0786	69.850 2.7500	69.832 2.7493	88.900 3.5000	88.936 3.5014	HJ-445624	69.820 2.7488	69.802 2.7481	88.852 3.4981	88.887 3.4995	80.98 3.188	2 3/4
0.0823	69.850 2.7500	69.832 2.7493	88.900 3.5000	88.936 3.5014	HJ-445628	69.820 2.7488	69.802 2.7481	88.852 3.4981	88.887 3.4995	80.98 3.188	
0.0839	76.200 3.0000	76.182 2.9993	95.250 3.7500	95.286 3.7514	HJ-486024	76.170 2.9988	76.152 2.9981	95.202 3.7481	95.237 3.7495	87.33 3.438	3
0.0879	76.200 3.0000	76.182 2.9993	95.250 3.7500	95.286 3.7514	HJ-486028	76.170 2.9988	76.152 2.9981	95.202 3.7481	95.237 3.7495	87.33 3.438	
0.0888	82.550 3.2500	82.527 3.2491	107.950 4.2500	107.986 4.2514	HJ-526828	82.514 3.2486	82.492 3.2477	107.902 4.2481	107.937 4.2495	98.43 3.875	3 1/4
0.0924	82.550 3.2500	82.527 3.2491	107.950 4.2500	107.986 4.2514	HJ-526832	82.514 3.2486	82.492 3.2477	107.902 4.2481	107.937 4.2495	98.43 3.875	
0.0965	88.900 3.5000	88.877 3.4991	114.300 4.5000	114.336 4.5014	HJ-567232	88.864 3.4986	88.842 3.4977	114.252 4.4981	114.287 4.4995	104.78 4.125	3 1/2
0.1011	95.250 3.7500	95.227 3.7491	120.650 4.7500	120.691 4.7516	HJ-607632	95.217 3.7487	95.192 3.7477	120.594 4.7478	120.635 4.7494	111.13 4.375	3 3/4
0.1060	101.600 4.0000	101.577 3.9991	127.000 5.0000	127.041 5.0016	HJ-648032	101.564 3.9986	101.542 3.9977	126.944 4.9978	126.985 4.9994	117.48 4.625	4
0.1099	107.950 4.2500	107.927 4.2491	133.350 5.2500	133.391 5.2516	HJ-688432	107.914 4.2486	107.892 4.2477	133.294 5.2478	133.335 5.2494	123.83 4.875	4 1/4
	114.300 4.5000	114.277 4.4991	152.400 6.0000	152.441 6.0016	HJ-729636	114.264 4.4986	114.242 4.4977	152.344 5.9978	152.385 5.9994	138.11 5.438	4 1/2
0.1137	114.300 4.5000	114.277 4.4991	152.400 6.0000	152.441 6.0016	HJ-729640	114.264 4.4986	114.242 4.4977	152.344 5.9978	152.385 5.9994	138.11 5.438	

*r_{as max} is equal to the minimum bearing chamfer (r_{s min}) at unmarked end.
⁽¹⁾ C_g factor for bearing without inner ring.

Continued on next page.



HJ TYPE — continued

INCH SERIES

- Check for availability.
- Nominal bearing diameters and widths shown.
- Tolerance tables found on page C139.
- Clearance fit suggested for outer ring when housing is stationary relative to load.
- Tight transition fit suggested if housing rotates relative to load.
- See page C141 for further discussion on mounting practices.
- Consult your Timken representative for oscillating applications (e.g., low radial clearance concerns).
- Unmarked end of outer ring should be assembled against housing shoulder to clear maximum allowed housing fillet ($r_{as\ max^*}$).
- Meets Military Standard MS 51961.

Shaft Diameter	Dimensions mm/in.				Bearing Designation	Used With Inner Ring Designation †	Load Ratings kN/lbf.				Approx. Wt. kg/lbs.	
	in.	F _w	D	C/B			r _{s min}	Basic Dynamic	Basic Static	Limiting Speed		
										Grease		Oil
							C	C ₀	RPM			
5	127.000	165.100	50.800	2.54	HJ-8010432	—	272	503	3430	5938	—	
	5.0000	6.5000	2.000	0.10			61200	113000				
	127.000	165.100	57.150	2.54	HJ-8010436	IR-648036 IR-688036	309	592	3430	5938	3.324	
	5.0000	6.5000	2.250	0.10			69400	133000			7.327	
	127.000	165.100	63.500	2.54	HJ-8010440	IR-648040	344	676	3430	5938	3.693	
	5.0000	6.5000	2.500	0.10			77300	152000			8.141	
5 1/2	139.700	177.800	63.500	2.54	HJ-8811240	IR-728840	350	712	3120	6438	4.014	
	5.5000	7.0000	2.500	0.10			78600	160000			8.849	
	139.700	177.800	76.200	2.54	HJ-8811248	IR-728848	415	885	3120	6438	4.817	
	5.5000	7.0000	3.000	0.10			93300	199000			10.62	
5 3/4	146.050	184.150	76.200	3.05	HJ-9211648	IR-769248	422	921	2960	6688	5.009	
	5.7500	7.2500	3.000	0.12			94800	207000			11.04	
6	152.400	190.500	63.500	3.05	HJ-9612040	IR-809640	369	792	2830	6938	4.335	
	6.0000	7.5000	2.500	0.12			83000	178000			9.557	
	152.400	190.500	76.200	3.05	HJ-9612048	IR-809648	442	996	2830	6938	5.202	
	6.0000	7.5000	3.000	0.12			99300	224000			11.47	
6 1/2	165.100	203.200	63.500	3.05	HJ-10412840	IR-8810440	383	850	2600	7438	4.656	
	6.5000	8.0000	2.500	0.12			86000	191000			10.26	
	165.100	203.200	76.200	3.05	HJ-10412848	IR-8810448	454	1054	2600	7438	5.582	
	6.5000	8.0000	3.000	0.12			102000	237000			12.31	
7 1/4	184.150	231.775	76.200	3.05	HJ-11614648	IR-9611648	526	1125	2340	8500	7.888	
	7.2500	9.1250	3.000	0.12			118300	253000			17.39	
7 3/4	196.850	244.475	76.200	3.05	HJ-12415448	IR-10412448	547	1205	2180	9000	8.370	
	7.7500	9.6250	3.000	0.12			123000	271000			18.45	
8 1/4	209.550	257.175	76.200	3.05	HJ-13216248	IR-11213248	565	1290	2040	9500	8.852	
	8.2500	10.1250	3.000	0.12			127000	290000			19.51	
8 3/4	222.250	269.875	76.200	4.06	HJ-14017048	IR-12014048	578	1370	1920	10000	9.333	
	8.7500	10.6250	3.000	0.16			130000	308000			20.58	
9 1/4	234.950	282.575	76.200	4.06	HJ-14817848	IR-12814848	605	1450	1810	10500	9.815	
	9.2500	11.1250	3.000	0.16			136000	326000			21.64	

† See pages C150-C153 for inch series inner rings. Order inner rings separately.

(1) C₀ factor for bearing without inner ring.



SEALED HEAVY-DUTY NEEDLE ROLLER BEARINGS

INCH SERIES

- Bearing diameters and widths listed are nominal.
- For inspection purposes, see tolerance tables on page C139.
- Available with one or two contact lip seals designed to retain lubricant and exclude foreign material.
- Single seals are normally installed in the stamped end of bearing.
- Seals limit the bearing operating temperature between -25° F and +225° F (-30° C and +110° C).
- For operating temperature outside of the above range, or if seals are exposed to unusual fluids, please consult your Timken representative.

Shaft Diameter	Dimensions mm/in.				Bearing Designation			Used With Inner Ring †	Load Ratings kN/lbf.		
	in.	F _w	D	C/B	r _{s min}	One Seal	Two Seals		Dynamic C	Static C ₀	Limiting Speed
								RPM	C ₀		
5/8	15.875 0.6250	28.575 1.1250	25.40 1.000	0.64 0.03	HJ-101816RS	HJ-101816.2RS	—	19.3 4350	20.7 4650	12000	0.025
3/4	19.050 0.7500	31.750 1.2500	25.40 1.000	1.02 0.04	HJ-122016RS	HJ-122016.2RS	IR-081216	20.7 4650	23.3 5240	10000	0.028
7/8	22.225 0.8750	34.925 1.3750	25.40 1.000	1.02 0.04	HJ-142216RS	HJ-142216.2RS	IR-101416	23.0 5180	27.9 6270	8700	0.031
1	25.400 1.0000	38.100 1.5000	25.40 1.000	1.02 0.04	HJ-162416RS	HJ-162416.2RS	IR-121616 IR-131616	25.3 5680	32.5 7300	7600	0.034
1 1/8	28.575 1.1250	41.275 1.6250	31.75 1.250	1.02 0.04	HJ-182620RS	HJ-182620.2RS	IR-141820	36.3 8170	53.8 12100	6800	0.040
1 1/4	31.750 1.2500	44.450 1.7500	31.75 1.250	1.02 0.04	HJ-202820RS	HJ-202820.2RS	IR-162020	37.4 8410	57.4 12900	6100	0.043
1 3/8	34.925 1.3750	47.625 1.8750	31.75 1.250	1.02 0.04	HJ-223020RS	HJ-223020.2RS	IR-182220	39.8 8950	64.1 14400	5600	0.046
1 1/2	38.100 1.5000	52.388 2.0625	31.75 1.250	1.52 0.06	HJ-243320RS	HJ-243320.2RS	IR-192420	47.6 10700	72.5 16300	5100	0.0480
1 5/8	41.275 1.6250	55.563 2.1875	31.75 1.250	1.52 0.06	HJ-263520RS	HJ-263520.2RS	IR-212620	48.5 10900	76.5 17200	2400	0.050
1 3/4	44.450 1.7500	58.738 2.3125	31.75 1.250	1.52 0.06	HJ-283720RS	HJ-283720.2RS	IR-222820 IR-232820 IR-242820	49.8 11200 —	81.0 18200 —	4400	0.053
2	50.800 2.0000	65.088 2.5625	31.75 1.250	1.52 0.06	HJ-324120RS	HJ-324120.2RS	IR-243220 IR-253220 IR-263220 IR-273220	53.8 12100 — —	93.0 20900 — —	3800	0.058
2 1/4	57.150 2.2500	76.200 3.0000	44.45 1.750	1.52 0.06	HJ-364828RS	HJ-364828.2RS	IR-283628	89.9 20200	164.1 36900	1700	0.068
2 1/2	63.500 2.5000	82.550 3.2500	44.45 1.750	2.03 0.08	HJ-405228RS	HJ-405228.2RS	IR-222620 IR-314028 IR-324028	97.0 21800 —	187.3 42100 —	3100	0.074
2 3/4	69.850 2.7500	88.900 3.5000	44.45 1.750	2.03 0.08	HJ-445628RS	HJ-445628.2RS	IR-354428 IR-364428	101.0 22700	203.3 45700	1400	0.079
3	76.200 3.0000	95.250 3.7500	44.45 1.750	2.03 0.08	HJ-486028RS	HJ-486028.2RS	IR-384828 IR-404828	107.2 24100	226.4 50900	2500	0.084

† See pages C150-C153 for inch series inner rings. Order inner rings separately.

§ Based on standard seal shaft contact speed of 305 m/min., 1000 ft./min.

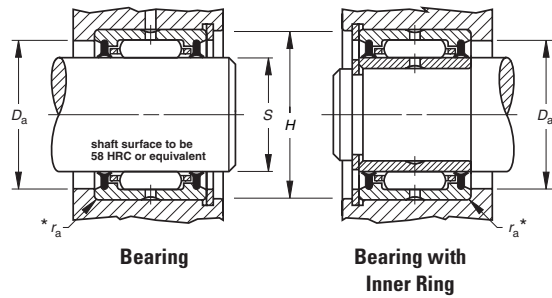
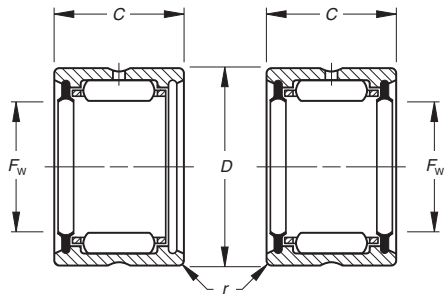

Approx. Wt. kg/lbs.	Mounting Dimensions mm/in.				Bearing Designation	Mounting Dimensions mm/in.				Shoulder Dia. ± 0.015	Shaft Diameter in.
	Clearance Fit					Tight Transition Fit					
	Max.	Min.	Min.	Max.		Max.	Min.	Min.	Max.		
	S		H			S		H		D_a	in.
0.07 0.15	15.875 0.6250	15.865 0.6246	28.575 1.1250	28.595 1.1258	-101816	15.860 0.6244	15.850 0.6240	28.547 1.1239	28.567 1.1247	23.83 0.938	5/8
0.08 0.17	19.050 0.7500	19.037 0.7495	31.750 1.2500	31.775 1.2510	-122016	19.030 0.7492	19.017 0.7487	31.717 1.2487	31.742 1.2497	26.97 1.062	3/4
0.09 0.19	22.225 0.8750	22.212 0.8745	34.925 1.3750	34.950 1.3760	-142216	22.205 0.8742	22.192 0.8737	34.892 1.3737	34.917 1.3747	30.18 1.188	7/8
0.10 0.21	25.400 1.0000	25.387 0.9995	38.100 1.5000	38.125 1.5010	-162416	25.380 0.9992	25.367 0.9987	38.067 1.4987	38.092 1.4997	33.32 1.312	1
0.13 0.29	28.575 1.1250	28.562 1.1245	41.275 1.6250	41.300 1.6260	-182620	28.555 1.1242	28.542 1.1237	41.242 1.6237	41.267 1.6247	36.53 1.438	1 1/8
0.15 0.32	31.750 1.2500	31.735 1.2494	44.450 1.7500	44.475 1.7510	-202820	31.725 1.2490	31.709 1.2484	44.417 1.7487	44.442 1.7497	39.67 1.562	1 1/4
0.16 0.35	34.925 1.3750	34.910 1.3744	47.625 1.8750	47.650 1.8760	-223020	34.900 1.3740	34.884 1.3734	47.592 1.8737	47.617 1.8747	42.88 1.688	1 3/8
0.20 0.43	38.100 1.5000	38.085 1.4994	52.388 2.0625	52.418 2.0637	-243320	38.075 1.4990	38.059 1.4984	52.349 2.0610	52.380 2.0622	47.63 1.875	1 1/2
0.21 0.46	41.275 1.6250	41.260 1.6244	55.563 2.1875	55.593 2.1887	-263520	41.250 1.6240	41.234 1.6234	55.524 2.1860	55.555 2.1872	50.80 2.000	1 5/8
0.22 0.49	44.450 1.7500	44.435 1.7494	58.738 2.3125	58.768 2.3137	-283720	44.425 1.7490	44.409 1.7484	58.699 2.3110	58.730 2.3122	53.98 2.125	1 3/4
0.25 0.55	50.800 2.0000	50.782 1.9993	65.088 2.5625	65.118 2.5637	-324120	50.770 1.9988	50.752 1.9981	65.049 2.5610	65.080 2.5622	60.33 2.375	2
0.53 1.17	57.150 2.2500	57.132 2.2493	76.200 3.0000	76.230 3.0012	-364828	57.120 2.2488	57.102 2.2481	76.162 2.9985	76.192 2.9997	68.28 2.688	2 1/4
0.59 1.29	63.500 2.5000	63.482 2.4993	82.550 3.2500	82.586 3.2514	-405228	63.470 2.4988	63.452 2.4981	82.502 3.2481	82.537 3.2495	74.63 2.938	2 1/2
0.64 1.40	69.850 2.7500	69.832 2.7493	88.900 3.5000	88.936 3.5014	-445628	69.820 2.7488	69.802 2.7481	88.852 3.4981	88.887 3.4995	80.98 3.188	2 3/4
0.68 1.51	76.200 3.0000	76.182 2.9993	95.250 3.7500	95.286 3.7514	-486028	76.170 2.9988	76.152 2.9981	95.202 3.7481	95.237 3.7495	87.33 3.438	3

* $r_{as \max}$ is equal to the minimum bearing chamfer ($r_{s \min}$) at unmarked end.



INNER RINGS

INCH SERIES

- Check for availability.
- Ideal choice where shaft not practical to use as inner raceway.
- Provided in inch nominal dimensions for use with inch series heavy-duty needle roller bearings.
- Designed to meet established inch tolerances.
- Selected size should be wider than matching drawn cup bearing.
- Maximum shaft fillet radius ($r_{as\ max}$) cannot exceed inner ring bore chamfer ($r_{s\ min}$) as shown.
- Optional centralized lubrication groove (bore) or through-hole available – specify when ordering.
- Designed to be axially clamped against shoulder for loose transition fit on shaft.
- After mounting, for tight transition fit (keeping inner ring from rotating relative to shaft), inner ring O.D. must not exceed raceway diameter on matching bearing.

Shaft Diameter	Dimensions mm/in.				Inner Ring Designation	Approx. Wt. kg/lbs.	Loose Transition Fit mm/in.		Inner Ring Designation	Interference Fit mm/in.		Used With Bearing Designation
	d	F	B	$r_{s\ min}$			Max.	Min.		Max.	Min.	
in.							S			S		
3/8	9.525	15.875	19.05	0.64	IR-061012	0.018	9.520	9.510	IR-061012	9.538	9.530	HJ-101812
	0.3750	0.6250	0.750	0.025			0.3748	0.3744		0.3755	0.3752	
1/2	12.700	19.050	19.05	1.02	IR-081212	0.023	12.692	12.682	IR-081212	12.715	12.708	HJ-122012
	0.5000	0.7500	0.750	0.04			0.4997	0.4993		0.5006	0.5003	
	12.700	19.050	25.40	1.02	IR-081216	0.032	12.692	12.682	IR-081216	12.715	12.708	HJ-122016
	0.5000	0.7500	1.000	0.04			0.4997	0.4993		0.5006	0.5003	
5/8	15.875	22.225	19.05	1.02	IR-101412	0.027	15.867	15.857	IR-101412	15.890	15.883	HJ-142212
	0.6250	0.8750	0.750	0.04			0.6247	0.6243		0.6256	0.6253	
	15.875	22.225	25.40	1.02	IR-101416	0.036	15.867	15.857	IR-101416	15.890	15.883	HJ-142216
	0.6250	0.8750	1.000	0.04			0.6247	0.6243		0.6256	0.6253	
11/16	17.463	22.225	19.05	1.02	IR-111412	0.023	17.455	17.445	IR-111412	17.478	17.470	HJ-142212
	0.6875	0.8750	0.750	0.04			0.6872	0.6868		0.6881	0.6878	
3/4	19.050	25.400	19.05	1.02	IR-121612	0.032	19.042	19.030	IR-121612	19.068	19.058	HJ-162412
	0.7500	1.0000	0.750	0.04			0.7497	0.7492		0.7507	0.7503	
	19.050	25.400	25.40	1.02	IR-121616	0.041	19.042	19.030	IR-121616	19.068	19.058	HJ-162416
	0.7500	1.0000	1.000	0.04			0.7497	0.7492		0.7507	0.7503	
13/16	20.638	25.400	25.40	1.02	IR-131616	0.032	20.630	20.617	IR-131616	20.655	20.645	HJ-162416
	0.8125	1.0000	1.000	0.04			0.8122	0.8117		0.8132	0.8128	
7/8	22.225	28.575	25.40	1.02	IR-141816	0.050	22.217	22.205	IR-141816	22.243	22.233	HJ-182616
	0.8750	1.1250	1.000	0.04			0.8747	0.8742		0.8757	0.8753	
	22.225	28.575	31.75	1.02	IR-141820	0.059	22.217	22.205	IR-141820	22.243	22.233	HJ-182620
	0.8750	1.1250	1.250	0.04			0.130	0.8747		0.8742	0.8757	
15/16	23.813	28.575	25.40	1.02	IR-151816	0.036	23.805	23.792	IR-151816	23.830	23.820	HJ-182616
	0.9375	1.1250	1.000	0.04			0.9372	0.9367		0.9382	0.9378	
	23.813	28.575	31.75	1.02	IR-151820	0.045	23.805	23.792	IR-151820	23.830	23.820	HJ-182620
	0.9375	1.1250	1.250	0.04			0.100	0.9372		0.9367	0.9382	
1	25.400	31.750	25.40	1.02	IR-162016	0.054	25.392	25.380	IR-162016	25.418	25.408	HJ-202816
	1.0000	1.2500	1.000	0.04			0.120	0.9997		0.9992	1.0007	
	25.400	31.750	31.75	1.02	IR-162020	0.068	25.392	25.380	IR-162020	25.418	25.408	HJ-202820
	1.0000	1.2500	1.250	0.04			0.150	0.9997		0.9992	1.0007	
1 1/8	28.575	34.925	25.40	1.02	IR-182216	0.059	28.567	28.555	IR-182216	28.593	28.583	HJ-223016
	1.1250	1.3750	1.000	0.04			0.130	1.1247		1.1242	1.1257	
	28.575	34.925	31.75	1.02	IR-182220	0.077	28.567	28.555	IR-182220	28.593	28.583	HJ-223020
	1.1250	1.3750	1.250	0.04			0.170	1.1247		1.1242	1.1257	
1 1/16	30.163	38.100	31.75	1.52	IR-192420	0.100	30.155	30.142	IR-192420	30.180	30.170	HJ-243320
	1.1875	1.5000	1.250	0.06			0.220	1.1872		1.1867	1.1882	
1 1/4	31.750	38.100	25.40	1.52	IR-202416	0.068	31.740	31.725	IR-202416	31.770	31.760	HJ-243316
	1.2500	1.5000	1.000	0.06			0.150	1.2496		1.2490	1.2508	
	31.750	38.100	31.75	1.52	IR-202420	0.082	31.740	31.725	IR-202420	31.770	31.760	HJ-243320
	1.2500	1.5000	1.250	0.06			0.180	1.2496		1.2490	1.2508	
1 5/16	33.338	41.275	25.40	1.52	IR-212616	0.086	33.327	33.312	IR-212616	33.358	33.348	HJ-263516
	1.3125	1.6250	1.000	0.06			0.190	1.3121		1.3115	1.3133	

Continued on next page.

- See tables for required bearing dimensions raceway diameter.
- After mounting, if O.D. of inner ring exceeds the required raceway diameter for matching bearing, ring should be ground to proper diameter while mounted on shaft.
- Unmarked end of inner ring to be assembled against the shaft shoulder to assure clearing the maximum allowable shaft fillet ($r_{as\ max}$) as indicated in tables shown.

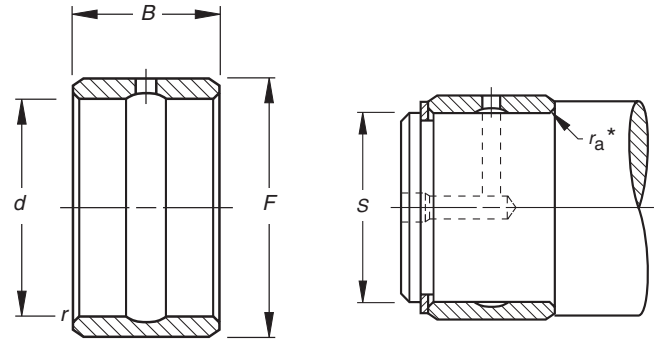

Shaft Diameter	Dimensions mm/in.				Inner Ring Designation	Approx. Wt. kg/lbs.	Loose Transition Fit mm/in.		Inner Ring Designation	Interference Fit mm/in.		Used With Bearing Designation
	d	F	B	r _{s min}			Max.	Min.		Max.	Min.	
in.	d	F	B	r _{s min}			S			S		
1 3/8	33.338	41.275	31.75	1.52	IR-212620	0.109	33.327	33.312	IR-212620	33.358	33.348	HJ-263520
	1.3125	1.6250	1.250	0.06		0.240	1.3121	1.3115		1.3133	1.3129	
1 3/8	34.925	41.275	31.75	1.52	IR-222620	0.091	34.915	34.900	IR-222620	34.945	34.935	HJ-263520
	1.3750	1.6250	1.250	0.06		0.200	1.3746	1.3740		1.3758	1.3754	
1 7/16	34.925	44.450	31.75	1.52	IR-222820	0.141	34.915	34.900	IR-222820	34.945	34.935	HJ-283720
	1.3750	1.7500	1.250	0.06		0.310	1.3746	1.3740		1.3758	1.3754	
1 7/16	36.513	44.450	25.40	1.52	IR-232816	0.095	36.502	36.487	IR-232816	36.533	36.523	HJ-283716
	1.4375	1.7500	1.000	0.06		0.210	1.4371	1.4365		1.4383	1.4379	
1 1/2	36.513	44.450	31.75	1.52	IR-232820	0.118	36.502	36.487	IR-232820	36.533	36.523	HJ-283720
	1.4375	1.7500	1.250	0.06		0.260	1.4371	1.4365		1.4383	1.4379	
1 1/2	38.100	44.450	25.40	1.52	IR-242816	0.077	38.090	38.075	IR-242816	38.120	38.110	HJ-283716
	1.5000	1.7500	1.000	0.06		0.170	1.4996	1.4990		1.5008	1.5004	
1 1/2	38.100	44.450	31.75	1.52	IR-242820	0.095	38.090	38.075	IR-242820	38.120	38.110	HJ-283720
	1.5000	1.7500	1.250	0.06		0.210	1.4996	1.4990		1.5008	1.5004	
1 9/16	38.100	50.800	31.75	1.52	IR-243220	0.209	38.090	38.075	IR-243220	38.120	38.110	HJ-324120
	1.5000	2.0000	1.250	0.06		0.460	1.4996	1.4990		1.5008	1.5004	
1 9/16	39.688	47.625	31.75	1.52	IR-253020	0.127	39.677	39.662	IR-253020	39.708	39.698	HJ-303920
	1.5625	1.8750	1.250	0.06		0.280	1.5621	1.5615		1.5633	1.5629	
1 9/16	39.688	50.800	31.75	1.52	IR-253220	0.186	39.677	39.662	IR-253220	39.708	39.698	HJ-324120
	1.5625	2.0000	1.250	0.06		0.410	1.5621	1.5615		1.5633	1.5629	
1 5/8	41.275	50.800	31.75	1.52	IR-263220	0.163	41.265	41.250	IR-263220	41.295	41.285	HJ-324120
	1.6250	2.0000	1.250	0.06		0.360	1.6246	1.6240		1.6258	1.6254	
1 11/16	42.863	50.800	25.40	1.52	IR-273216	0.109	42.852	42.837	IR-273216	42.883	42.873	HJ-324116
	1.6875	2.0000	1.000	0.06		0.240	1.6871	1.6865		1.6883	1.6879	
1 11/16	42.863	50.800	31.75	1.52	IR-273220	0.136	42.852	42.837	IR-273220	42.883	42.873	HJ-324120
	1.6875	2.0000	1.250	0.06		0.300	1.6871	1.6865		1.6883	1.6879	
1 3/4	44.450	57.150	38.10	1.52	IR-283624	0.286	44.440	44.425	IR-283624	44.470	44.460	HJ-364824
	1.7500	2.2500	1.500	0.06		0.630	1.7496	1.7490		1.7508	1.7504	
1 3/4	44.450	57.150	44.45	1.52	IR-283628	0.336	44.440	44.425	IR-283628	44.470	44.460	HJ-364828
	1.7500	2.2500	1.750	0.06		0.740	1.7496	1.7490		1.7508	1.7504	
1 15/16	49.213	63.500	38.10	2.03	IR-314024	0.358	49.202	49.187	IR-314024	49.233	49.223	HJ-405224
	1.9375	2.5000	1.500	0.08		0.790	1.9371	1.9365		1.9383	1.9379	
1 15/16	49.213	63.500	44.45	2.03	IR-314028	0.417	49.202	49.187	IR-314028	49.233	49.223	HJ-405228
	1.9375	2.5000	1.750	0.08		0.920	1.9371	1.9365		1.9383	1.9379	
2	50.800	63.500	38.10	2.03	IR-324024	0.322	50.790	50.772	IR-324024	50.823	50.810	HJ-405224
	2.0000	2.5000	1.500	0.08		0.710	1.9996	1.9989		2.0009	2.0004	
2	50.800	63.500	44.45	2.03	IR-324028	0.376	50.790	50.772	IR-324028	50.823	50.810	HJ-405228
	2.0000	2.5000	1.750	0.08		0.830	1.9996	1.9989		2.0009	2.0004	
2 3/16	55.563	69.850	44.45	2.03	IR-354428	0.467	55.552	55.535	IR-354428	55.585	55.573	HJ-445628
	2.1875	2.7500	1.750	0.08		1.030	2.1871	2.1864		2.1884	2.1879	
2 1/4	57.150	69.850	38.10	2.03	IR-364424	0.358	57.140	57.122	IR-364424	57.173	57.160	HJ-445624
	2.2500	2.7500	1.500	0.08		0.790	2.2496	2.2489		2.2509	2.2504	

Continued on next page.



INNER RINGS — *continued*

INCH SERIES

- Check for availability.
- Ideal choice where shaft not practical to use as inner raceway.
- Provided in inch nominal dimensions for use with inch series heavy-duty needle roller bearings.
- Designed to meet established inch tolerances.
- Selected size should be wider than matching drawn cup bearing.
- Maximum shaft fillet radius ($r_{s \max}$) cannot exceed inner ring bore chamfer ($r_{s \min}$) as shown.
- Optional centralized lubrication groove (bore) or through-hole available – specify when ordering.
- Designed to be axially clamped against shoulder for loose transition fit on shaft.
- After mounting, for tight transition fit (keeping inner ring from rotating relative to shaft), inner ring O.D. must not exceed raceway diameter on matching bearing.

Shaft Diameter	Dimensions mm/in.				Inner Ring Designation	Approx. Wt. kg/lbs.	Loose Transition Fit mm/in.		Inner Ring Designation	Interference Fit mm/in.		Used With Bearing Designation
	d	F	B	$r_{s \min}$			Max.	Min.		Max.	Min.	
in.							S			S		
2 3/8	57.150	69.850	44.45	2.03	IR-364428	0.417	57.140	57.122	IR-364428	57.173	57.160	HJ-445628
	2.2500	2.7500	1.750	0.08			2.2496	2.2489		2.2509	2.2504	
2 1/2	60.325	76.200	44.45	2.03	IR-384828	0.562	60.315	60.297	IR-384828	60.348	60.335	HJ-486028
	2.3750	3.0000	1.750	0.08			2.3746	2.3739		2.3759	2.3754	
2 1/2	63.500	76.200	38.10	2.03	IR-404824	0.395	63.490	63.472	IR-404824	63.523	63.510	HJ-486024
	2.5000	3.0000	1.500	0.08			2.4996	2.4989		2.5009	2.5004	
2 3/4	63.500	76.200	44.45	2.03	IR-404828	0.463	63.490	63.472	IR-404828	63.523	63.510	HJ-486028
	2.5000	3.0000	1.750	0.08			2.4996	2.4989		2.5009	2.5004	
2 3/4	69.850	82.550	44.45	2.03	IR-445228	0.503	69.840	69.822	IR-445228	69.873	69.860	HJ-526828
	2.7500	3.2500	1.750	0.08			2.7496	2.7489		2.7509	2.7504	
2 15/16	69.850	82.550	50.80	2.03	IR-445232	0.576	69.840	69.822	IR-445232	69.873	69.860	HJ-526832
	2.7500	3.2500	2.000	0.08			2.7496	2.7489		2.7509	2.7504	
2 15/16	74.613	88.900	50.80	2.03	IR-475632	0.694	74.602	74.585	IR-475632	74.635	74.623	HJ-567232
	2.9375	3.5000	2.000	0.08			2.9371	2.9364		2.9384	2.9379	
3	76.200	88.900	50.80	2.03	IR-485632	0.621	76.190	76.172	IR-485632	76.223	76.210	HJ-567232
	3.0000	3.5000	2.000	0.08			2.9996	2.9989		3.0009	3.0004	
3 1/8	79.375	95.250	50.80	2.54	IR-506032	0.880	79.365	79.347	IR-506032	79.398	79.385	HJ-607632
	3.1250	3.7500	2.000	0.1			3.1246	3.1239		3.1259	3.1254	
3 1/4	82.550	95.250	50.80	2.54	IR-526032	0.708	82.537	82.517	IR-526032	82.578	82.563	HJ-607632
	3.2500	3.7500	2.000	0.1			3.2495	3.2487		3.2511	3.2505	
3 1/4	82.550	101.600	50.80	2.54	IR-526432	1.089	82.537	82.517	IR-526432	82.578	82.563	HJ-648032
	3.2500	4.0000	2.000	0.1			3.2495	3.2487		3.2511	3.2505	
3 3/8	85.725	101.600	50.80	2.54	IR-546432	0.930	85.712	85.692	IR-546432	85.753	85.738	HJ-648032
	3.3750	4.0000	2.000	0.1			3.3745	3.3737		3.3761	3.3755	
3 1/2	88.900	101.600	50.80	2.54	IR-566432	0.757	88.887	88.867	IR-566432	88.928	88.913	HJ-648032
	3.5000	4.0000	2.000	0.1			3.4995	3.4987		3.5011	3.5005	
3 1/2	88.900	107.950	50.80	2.54	IR-566832	1.179	88.887	88.867	IR-566832	88.928	88.913	HJ-688432
	3.5000	4.2500	2.000	0.1			3.4995	3.4987		3.5011	3.5005	
3 3/4	95.250	107.950	50.80	2.54	IR-606832	1.012	95.237	95.217	IR-606832	95.278	95.263	HJ-688432
	3.7500	4.2500	2.000	0.1			3.7495	3.7487		3.7511	3.7505	
3 3/4	95.250	114.300	57.15	2.54	IR-607236	1.406	95.237	95.217	IR-607236	95.278	95.263	HJ-729636
	3.7500	4.5000	2.250	0.1			3.7495	3.7487		3.7511	3.7505	
3 3/4	95.250	114.300	63.50	2.54	IR-607240	1.565	95.237	95.217	IR-607240	95.278	95.263	HJ-729640
	3.7500	4.5000	2.500	0.1			3.7495	3.7487		3.7511	3.7505	
4	101.600	127.000	57.15	2.54	IR-648036	2.046	101.587	101.567	IR-648036	101.628	101.613	HJ-8010436
	4.0000	5.0000	2.250	0.1			4.510	3.9995		3.9987	4.0011	
4	101.600	127.000	63.50	2.54	IR-648040	2.272	101.587	101.567	IR-648040	101.628	101.613	HJ-8010440
	4.0000	5.0000	2.500	0.1			5.010	3.9995		3.9987	4.0011	
4 1/4	107.950	127.000	57.15	2.54	IR-688036	1.565	107.937	107.917	IR-688036	107.978	107.963	HJ-8010436
	4.2500	5.0000	2.250	0.1			3.450	4.2495		4.2487	4.2511	
4 1/2	114.300	139.700	63.50	2.54	IR-728840	2.495	114.287	114.267	IR-728840	114.328	114.313	HJ-8811240
	4.5000	5.5000	2.500	0.1			5.500	4.4995		4.4987	4.5011	

Continued on next page.



NEEDLE ROLLER BEARINGS



NOTES

C

