

Internal gear pump PGH

Fixed displacement

Series 2X

RE 10223

Edition: 04.2013

Replaces: 03.2005

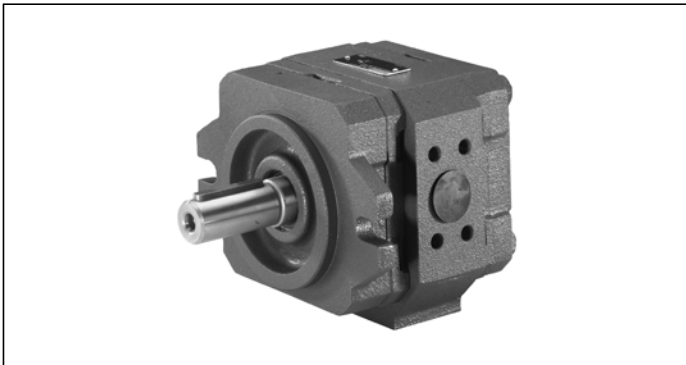

- ▶ Frame sizes 2 and 3
- ▶ Size 5 to 16
- ▶ Maximum pressure 350 bar
- ▶ Displacement 5.2 to 16.0 cm³

Features

- ▶ Fixed displacement
- ▶ Low operating noise
- ▶ Low flow pulsation
- ▶ High efficiency even at low rotational speed and viscosity due to sealing gap compensation
- ▶ Suitable for a wide viscosity and speed range
- ▶ All frame sizes and sizes can be optionally combined with each other
- ▶ Can be combined with internal gear pumps, radial piston pumps and external gear pumps

Contents

Ordering code	2
Functional description	3
Technical data	4
Characteristic median values for frame sizes 2 and 3	5
Dimensions frame size 2	6
Dimensions frame size 3	7
Multiple pump units	9
SAE connection flanges	12
Pump safety block	12
Engineering notes	13
Installation instructions	14
Commissioning instructions	15

Ordering code

01	02	03	04	05	06	07	08	09	10	11
PG	H		2X	/			07		U2	

Type

01	Internal gear pump, fixed displacement, gap compensated	PG
----	---	-----------

Series

02	High pressure pump, maximum pressure 350 bar	H
----	--	----------

Frame sizes BG

03	BG2	2
	BG3	3

Unit series

04	Unit series 20 to 29 (20 to 29: unchanged installation and connection dimensions)	2X
----	---	-----------

Sizes

		NG	
05	BG2	5	005
		6	006
		8	008
	BG3	11	011
		13	013
		16	016

Directions of rotation

06	Viewed on drive shaft	clockwise	R
		counter-clockwise	L

Drive shafts

07	Parallel keyed shaft, DIN 6885		E
	Splined shaft to SAE J744 with involute spline to ANSI B92.1a	16-4 (A) 9T 16/32DP	R
		19-4 11T 16/32DP	S

Line ports

08	Suction and pressure port to SAE, pressure port standard pressure series	07
----	--	-----------

Seals

09	FKM (fluor-caoutchouc)	V
	FKM (fluor-caoutchouc), shaft seal in NBR (nitrile-caoutchouc) ¹⁾	W

Mounting flange

10	SAE 2-hole	U2
----	------------	-----------

11	Further parameters in clear text	
----	----------------------------------	--

Ordering example

PGH3-2X/016RE07VU2

Material number

R900951305

Not all of the variants according to the ordering code are possible! Please select the desired pump with the help of the selection table (page 6 to 8) or after consultation with Bosch Rexroth.

¹⁾ For HFC-fluids

Functional description

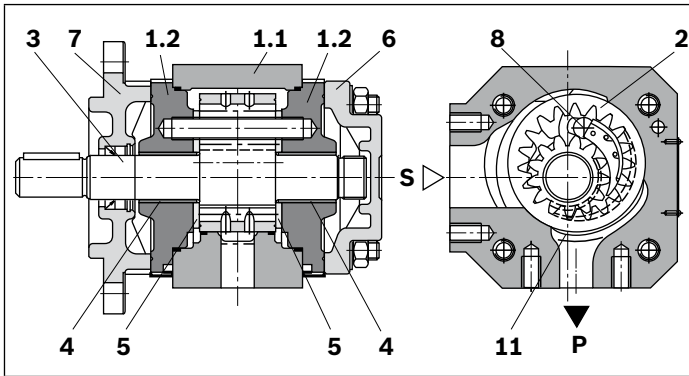

Assembly

PGF hydraulic pumps are leak gap-compensated internal gear pumps with a fixed displacement. They consist basically of housing (1.1), bearing cover (1.2), ring gear (2), pinion shaft (3), slide bearings (4), axial discs (5), end cover (6), mounting flange (7) and stop pin (8), as well as the segment assembly (9), which is composed of a segment (9.1), segment carrier (9.2) and the sealing rolls (9.3).

Suction and displacement process

The hydro dynamically supported pinion shaft (3) drives the internally toothed ring gear (2) in the direction of rotation shown.

During rotation, the volume is increased in the suction area over an angle of approx. 90°. A negative pressure is generated and fluid flows into the chambers.

The sickle-shaped segment assembly (9) separates the suction chamber from the pressure chamber. Within the pressure chamber, the teeth of the pinion shaft (3) mesh with the tooth spaces of the ring gear (2). The fluid is then displaced through the pressure channel (P).

Axial compensation

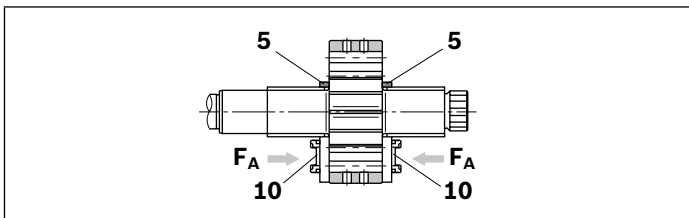

The axial compensation force F_A acts in the area of the pressure chamber and is generated by the pressure zone (10) in the axial discs (5).

The axial, longitudinal gaps between rotating and fixed parts are therefore extremely small and ensure optimum axial sealing of the pressure chamber.

Radial compensation

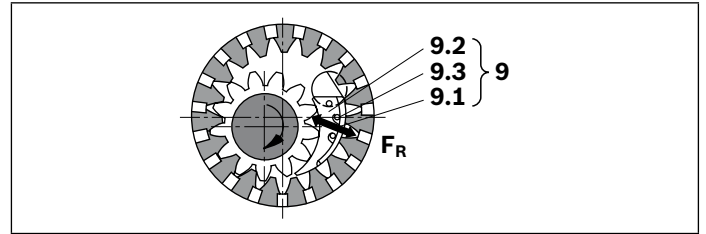

The radial compensation force F_R acts on the segment (9.1) and segment carrier (9.2).

Depending on the operating pressure the two segment assemblies (9.1) and (9.2) are pressed against the pinion shaft-head diameter (3) and the ring gear (2). The area ratios and the position of the sealing rolls (9.3) between the segment and segment carrier are designed to provide virtually gap-free sealing between the ring gear (2), the segment assembly (9) and the pinion shaft (3). Spring elements under the sealing rolls (9.3) ensure adequate contact pressure, even at very low pressures.

Hydrodynamic and hydrostatic bearing

The forces acting on the pinion shaft (3) are absorbed by hydro dynamically lubricated radial slide bearings (4) while those acting on the ring gear (2) are absorbed by the hydrostatic bearing (11).

Splines

Involute splining was selected for the splines. Their long length of contact results in a low flow and pressure pulsation; these low pulsation rates greatly contribute to the low-noise operation.

▼ Symbol

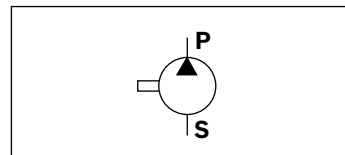

Technical data

Frame size		BG	2	2	2	3	3	3
Size		NG	5	6	8	11	13	16
Displacement, geometric	V_g	cm ³	5.24	6.5	8.2	11.0	13.3	16.0
Drive speed	n_{min}	rpm	600	600	600	600	600	600
	n_{max}	rpm	3000	3000	3000	3000	3000	3000
Operating pressure, absolute								
Inlet	p	bar	0.8 to 2 (short-term at start 0.6 bar)					
Outlet	continuous							
	Standard fluid	p_n	bar	315	315	315	315	315
	Special fluid ¹⁾	p_n	bar	210	210	210	210	210
	intermittend ²⁾							
	Standard fluid	p_{max}	bar	350	350	350	350	350
	Special fluid ¹⁾	p_{max}	bar	230	230	230	230	230
Flow (at $n = 1450$ rpm, $p = 10$ bar, $\nu = 46$ mm ² /s)	q_v	l/min	7.5	9.3	11.8	15.8	19.1	23.0
weight	m	kg	4.3	4.4	4.6	4.8	5	5.3
Shaft loading	Radial and axial forces (e. g., belt pulley) only after consultation							
Type of mounting	Flange mounting							
Hydraulic fluid								
Standard fluid	HLP mineral oil according to DIN 51524 Part 2							
Special fluid	<ul style="list-style-type: none"> ▶ Environmentally acceptable fluids HEES according to DIN ISO 15380 ▶ Fire resistant anhydrous fluids HFD-U according to VDMA 24317 ▶ Hydrous polymer-solutions HFC according to DIN EN ISO 12922³⁾ ▶ Observe our application instructions and application requirements in the data sheets 90220 (HLP), 90221 (HEES) and 90222 (HFD-U). ▶ Other fluids on request! 							
Temperature range	°C	Standard fluid	-10 to +80, for other temperatures please consult us!					
		Special fluid	-10 to +50, for other temperatures please consult us!					
Ambient temperature range	°C	-20 to +60						
Viscosity range	mm/s ²	10 to 300; permissible starting viscosity 2000						
Maximum permissible degree of contamination of the hydraulic fluid.	Class 20/18/15 ⁴⁾							
Cleanliness level according to ISO 4406 (c)								

Note

Please contact us if the unit is to be used outside the specified values!

- 1) For special fluids observe restrictions of the technical data!
- 2) Maximum 10 s, at most 50 % of the duty cycle
- 3) Execution of seals W
- 4) Cleanliness levels specified for the components must be maintained in the hydraulic systems. Effective filtration prevents malfunctions and simultaneously extends the service life of the components.
 For the selection of the filters see data sheets 50070, 50076, 50081, 50086, 50087 and 50088.

Characteristic median values for frame sizes 2 and 3

▼ **Flow**

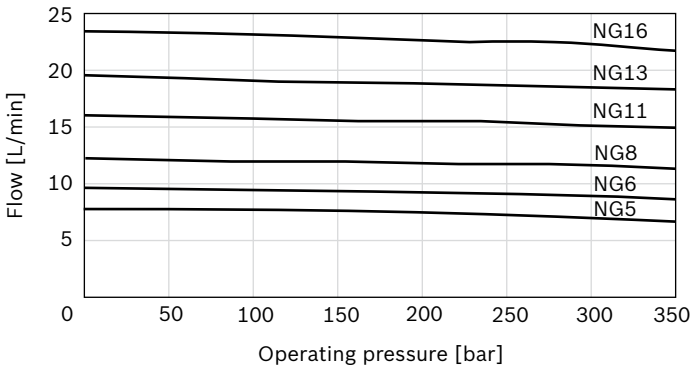

▼ **Efficiency**

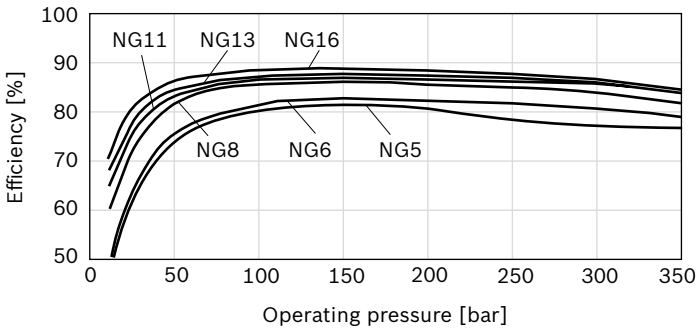

▼ **Drive power**

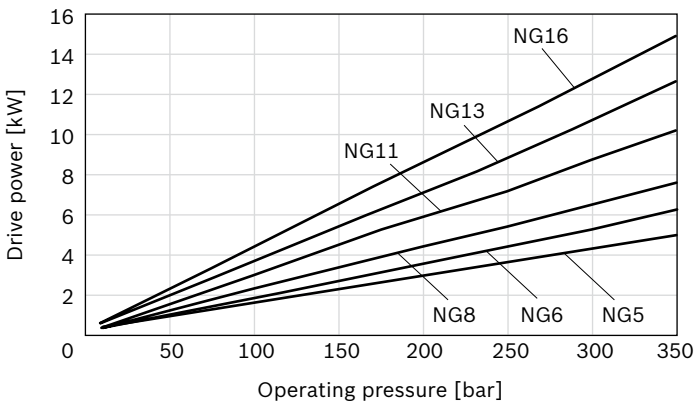

▼ **Sound pressure level**

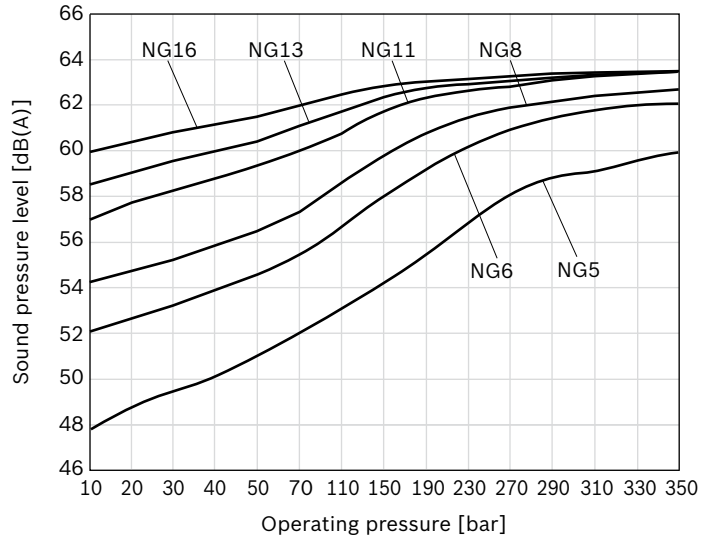

Note

- ▶ Characteristics measured at $n = 1450$ rpm;
 $\nu = 41 \text{ mm}^2/\text{s}$; $\theta = 50 \text{ }^\circ\text{C}$
- ▶ Sound pressure level measured in acoustic room according to DIN 45635, page 26;
 distance sound sensor – pump = 1 m

Dimensions frame size 2

With parallel keyed shaft or splined shaft SAE J744 and SAE-mounting flange 82-2

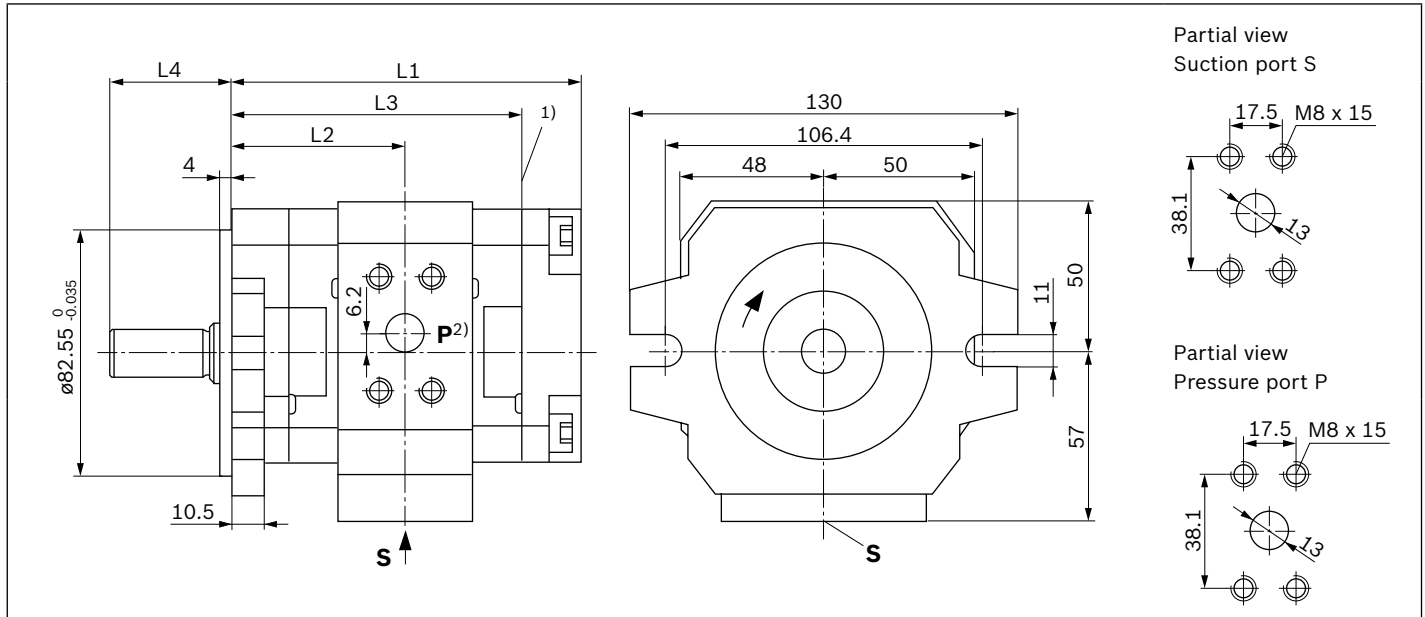

Type		Material numbers	L1	L2	L3	L4	Suction port S ⁴⁾	Pressure port P ⁴⁾
PGH2-2X/005	R ³⁾ E 07VU2	R900968999	110	54.2	89.5	41	1/2 in; 5000 psi	1/2 in; 5000 psi
	L	R900703725						
	R ³⁾ R 07VU2	R900972378				31.5		
	L	R900703727						
006	R ³⁾ E 07VU2	R900951301	112.5	55.5	92	41	1/2 in; 5000 psi	1/2 in; 5000 psi
	L	R900961547						
	R ³⁾ R 07VU2	R900961549				31.5		
	L	R900961550						
008	R ³⁾ E 07VU2	R900951302	116	57.3	95.5	41	1/2 in; 5000 psi	1/2 in; 5000 psi
	L	R900961548						
	R ³⁾ R 07VU2	R900961551				31.5		
	L	R900961552						

▼ Parallel keyed shaft DIN 6885

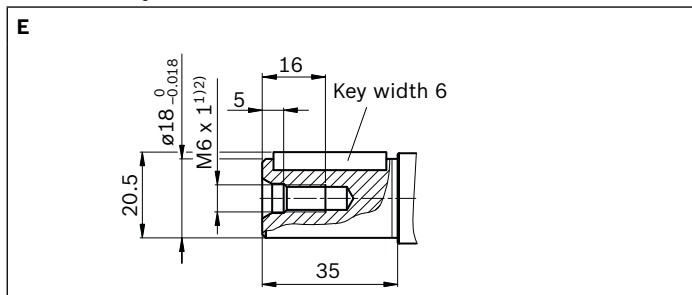

▼ Splined shaft SAE J744

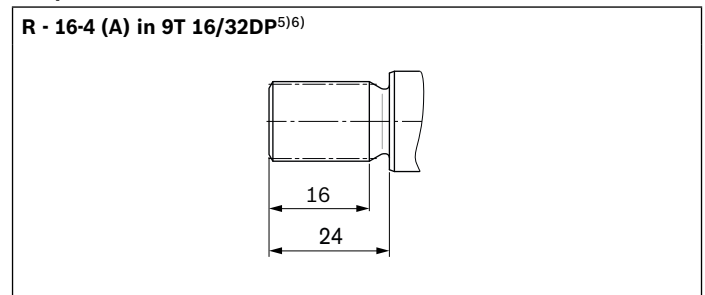

- At multiple pump units the combination part starts here
- Shown are pumps in clockwise rotation, pumps in counter clockwise rotation have the pressure port on the opposite side!
- Preferably available

- Standard pressure range
- In multiple pump units suitable as middle and rear pump
- Involute spline to ANSI B92.1a, 30° pressure angle, flat root, side fit, tolerance class 5

Dimensions frame size 3

With parallel keyed shaft and SAE-mounting flange 101-2

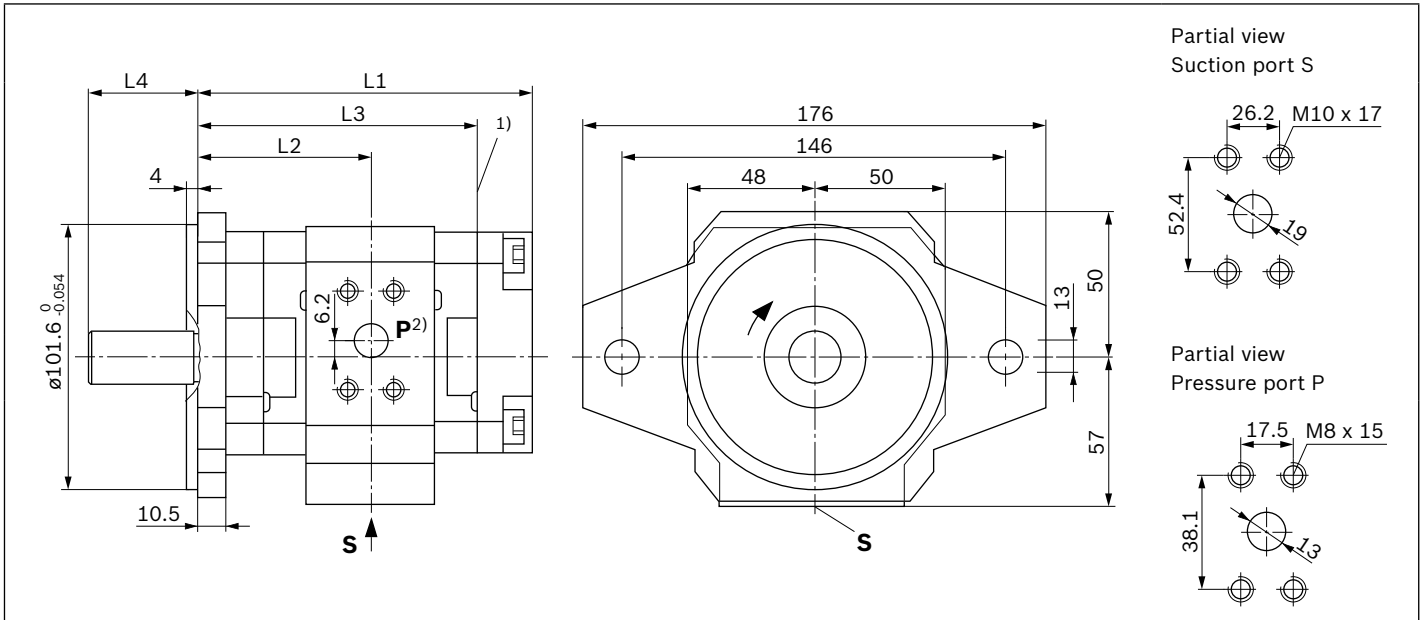

Type	Material numbers	L1	L2	L3	L4	Suction port S ⁴⁾	Pressure port P ⁴⁾	
PGH3-2X/ 011	R ³⁾ E 07VU2	R900951303	128	66.5	107.5	41	1 in; 3000 psi	1/2 in; 5000 psi
	L	R900961553						
013	R ³⁾ E 07VU2	R900951304	133	69	112.5	41	1 in; 3000 psi	1/2 in; 5000 psi
	L	R900961554						
016	R ³⁾ E 07VU2	R900951305	138	71.5	117.5	41	1 in; 3000 psi	1/2 in; 5000 psi
	L	R900961555						

▼ **Parallel keyed shaft DIN 6885**

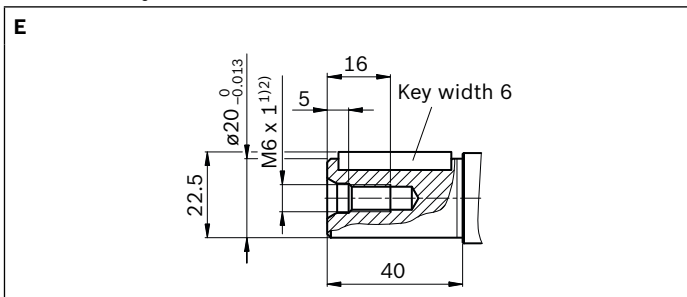

- 1) At multiple pump units the combination part starts here
- 2) Shown are pumps in clockwise rotation, pumps in counter clockwise rotation have the pressure port on the opposite side!
- 3) Preferably available
- 4) Standard pressure range

With splined shaft SAE J744 and SAE-mounting flange 82-2

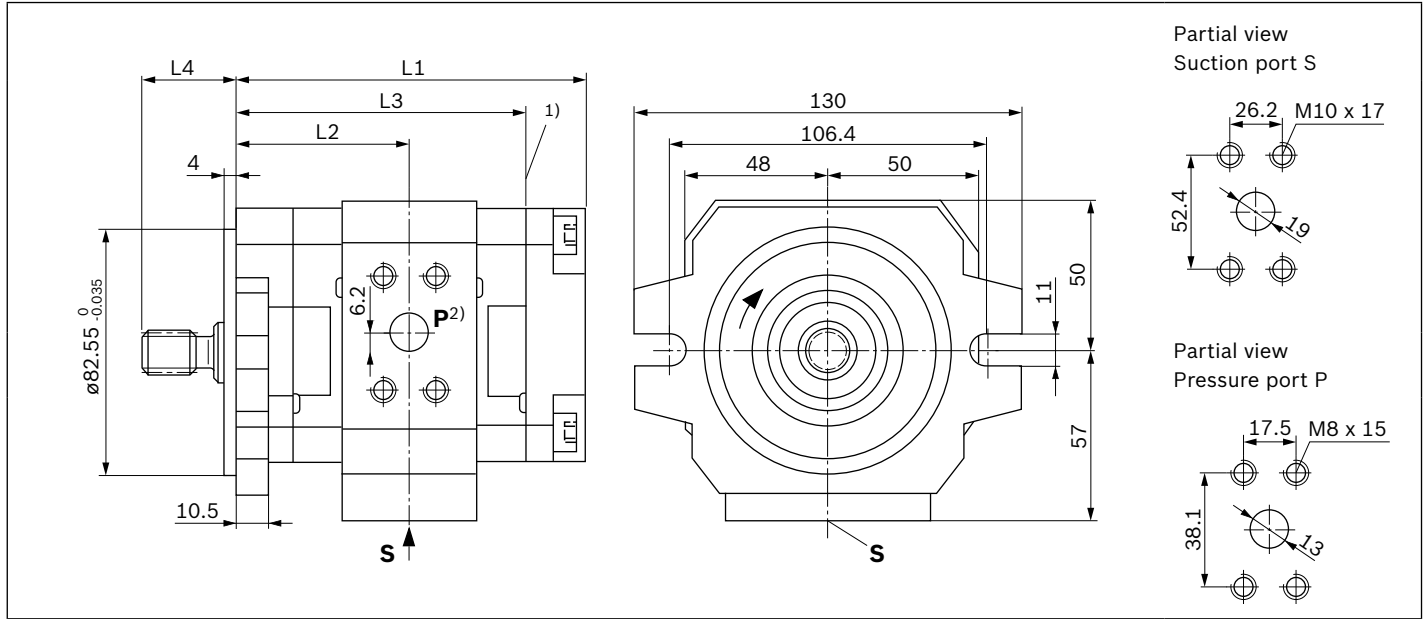

Type	Material numbers	L1	L2	L3	L4	Suction port S ⁴⁾	Pressure port P ⁴⁾
PGH3-2X/ 011	R ³⁾ R 07VU2	R900961556	60	101	31.5	1 in; 3000 psi	1/2 in; 5000 psi
	L	R900961559					
	R S 07VU2	R901267181					
013	R ³⁾ R 07VU2	R900961557	62.5	106	31.5	1 in; 3000 psi	1/2 in; 5000 psi
	L	R900961560					
	R S 07VU2	R901281697					
016	R ³⁾ R 07VU2	R900961558	65	111	31.5	1 in; 3000 psi	1/2 in; 5000 psi
	L	R900961561					
	R S 07VU2	R901281698					

▼ **Splined shaft SAE J744**

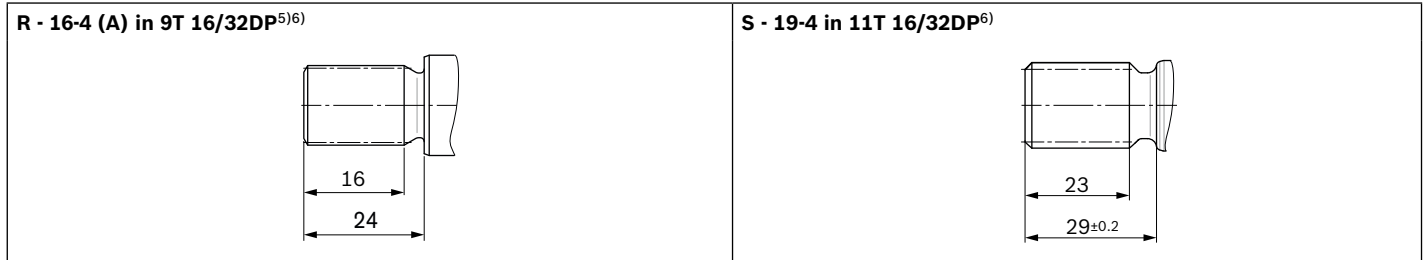

- 1) At multiple pump units the combination part starts here
- 2) Shown are pumps in clockwise rotation, pumps in counter clockwise rotation have the pressure port on the opposite side!
- 3) Preferably available
- 4) Standard pressure range
- 5) In multiple pump units suitable as middle and rear pump
- 6) Involute spline according to ANSI B92.1a, 30° pressure angle, flat root, side fit, tolerance class 5

Multiple pump units

All internal gear pumps type PGH are combinable, every pump has a through drive connection. The combination options and the material numbers for the necessary combination parts can be taken from the following table.

Rear pump	Front pump	
	PGH2-2X	PGH3-2X
PGH2-2X/...R...U2	R900886137	R900886137
PGH3-2X/...R...U2	R900886137	R900886137
PGP2-2X/...J...U2	R900886137	R900886137
PGF2-2X/...J...U2	R900886137	R900886137
AZPF...RR...B	R900886137	R900886137
PR4-1X...WA	R901015657	R901015657

10 **PGH Series 2X** | Internal gear pump
Multiple pump units

Ordering code

01	02	03	04	05	06	07	08	09	10	11	12	13	14	15
		/	+	/	+	/				+		+		

Type

01	2-fold	P2
	3-fold	P3

02	Series of the first pump ¹⁾	
----	--	--

03	Size of the first pump ¹⁾	
----	--------------------------------------	--

04	Series of the second pump ¹⁾	
----	---	--

05	Size of the second pump ¹⁾	
----	---------------------------------------	--

06	Series of the third pump ¹⁾	
----	--	--

07	Size of the third pump ¹⁾	
----	--------------------------------------	--

Direction of rotation

08	Viewed on drive shaft	clockwise	R
		counter-clockwise	L

Drive shaft of the first pump

09	Parallel keyed shaft, DIN 6885		E
	Splined shaft to SAE J744 with involute tooth system to ANSI B92.1a	16-4 (A) 9T 16/32DP	R
		19-4 11T 16/32DP	S

Line port of the first pump

10	Suction and pressure port to SAE, pressure port standard pressure series	07
----	--	-----------

Drive shaft of the second pump²⁾

11	Parallel keyed shaft, DIN 6885		A
	Splined shaft to SAE J744 with involute tooth system to ANSI B92.1a	16-4 (A) 9T 16/32DP	J
			R

Line port of the second pump

12	Suction and pressure port to SAE, pressure port standard pressure series	07
----	--	-----------

Drive shaft of the third pump²⁾

13	Parallel keyed shaft, DIN 6885		A
	Splined shaft to SAE J744 with involute tooth system to ANSI B92.1a	16-4 (A) 9T 16/32DP	J
			R

Line port of the third pump

14	Suction and pressure port to SAE, pressure port standard pressure series	07
----	--	-----------

Mounting flange of the first pump

15	SAE 2-hole ²⁾	U2
----	--------------------------	-----------

1) Detailed information see ordering code page 2

2) See table page 9

Dimensions

The dimensional drawings show the first pump and the combination part.¹⁾

PGH2/PGH3

PGH2 with combination part for PGH2, PGH3, PGF2, PGP2, AZPF

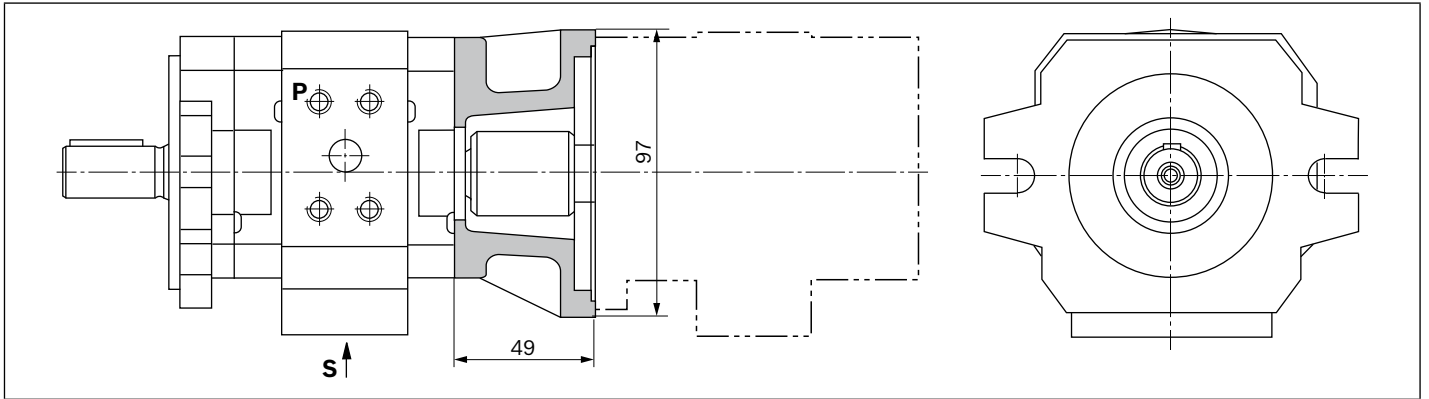

PGH2/PGH3 + R4-Mini

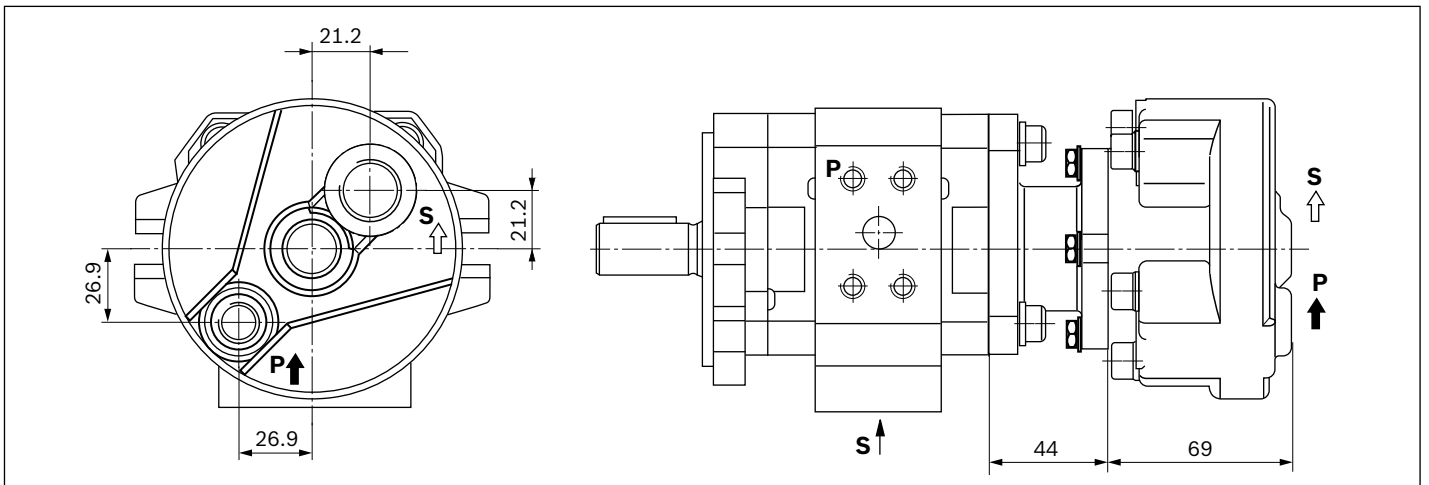

¹⁾ Dimensions of the single pumps see page 6 to 8 or the relevant data sheets of the rear pump.

SAE connection flanges

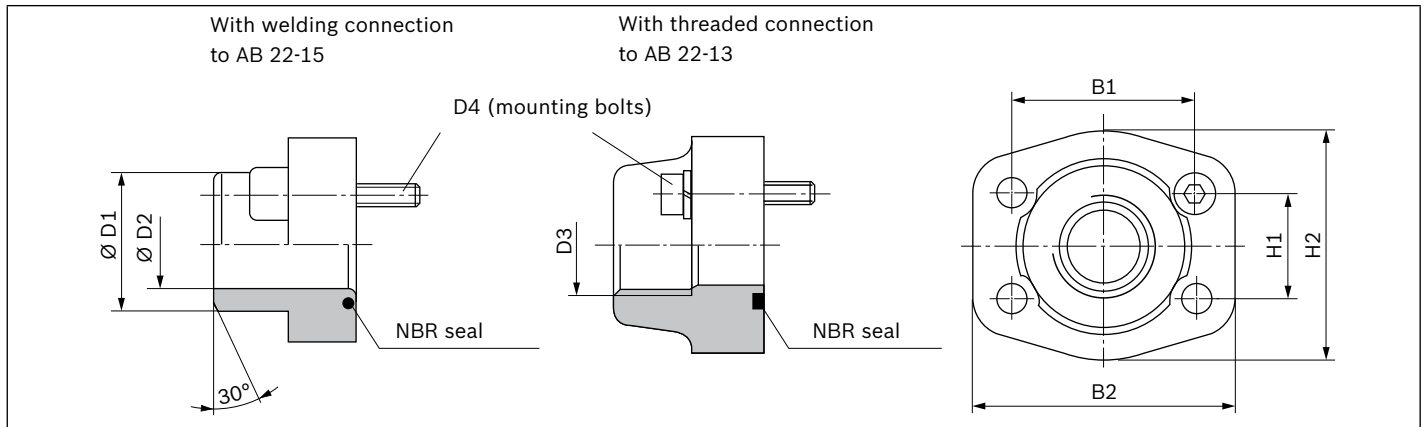

PGH		Flange NG, pressure	Material number ¹⁾ for flange with		Dimensioning							
Suction flange	Pressure flange		Welding port	Threaded connection ²⁾	B1	B2	H1	H2	D1	D2	D3	D4
PGH2/005/ 006/008	PGH2/005/ 006/008 PGH3/011/ 013/016	1/2 in 5000 psi	R900026298	R900024200	38.1	54	17.5	46	20	14	G1/2	M8 x 30
PGH3/011/013/016,	-	1 in 3000 psi	R900012937	R900014154	52.4	70	26.2	59	35	27	G1	M10 x 35

Pump safety block

For limitation of the operating pressure or (and) for solenoid-actuated relief of operating pressure we recommend our pump-pressure-safety-block to data sheets 25880 and 25891.

1) The material numbers comprise the flange, the O-ring (NBR) and the mounting bolts.

2) Pipe thread "G" according to DIN EN ISO 228/1

Engineering notes

Extensive notes and suggestions can be found in the Hydraulic Trainer, volume 3 "Project planning recommendations and design of hydraulic systems".

When using internal gear pumps, provide an additional manual, switchable or automatic air bleeding option. The air bleeding point for manual air bleeding must be provided in the pressure line upstream of the first valve or check valve to ensure air bleeding can be performed depressurized.

Technical data

All mentioned technical data are dependent on manufacturing tolerances and are applicable for certain boundary conditions.

Note that certain deviations are therefore possible and that technical data may vary when boundary conditions (e. g., viscosity) change.

Characteristic curves

When dimensioning the drive motor, observe the maximum possible application data on the basis of the characteristics shown on the page 5.

Sound pressure level

The shown values for the sound pressure level on page 5 were measured in dependence on DIN 45635, sheet 26. This means that only the noise emitted by the pump is shown. Ambient influences (installation site, piping etc.) were not taken into account.

These values always refer to only one pump.

With internal gear pumps, the excitation of valves, pipelines, machine parts, etc. is very low due to the low flow pulsation (approx. 2 to 3 %).

Nevertheless, under unfavorable conditions, the sound pressure level at the installation site of the power unit can be 5 to 10 dB(A) higher than the values of the pump itself.

Multiple pump units

- ▶ The same general technical data apply as for the single pumps (see page 4).
- ▶ Combined pumps must all have the same direction of rotation.
- ▶ The pump with the largest input drive torque should be taken as the first pump.
- ▶ The engineer must verify the maximum through-drive torque for each application. This also applies for existing (coded) multiple pumps.
- ▶ The sum of all input torques in a multiple pump unit may not exceed the permissible input torque of the first pump.
- ▶ Common suction is not possible.
- ▶ Before operating pump combinations with different hydraulic fluids, please contact Bosch Rexroth.
- ▶ The middle and the rear pump must feature the drive shaft execution "R" (stronger spline).
- ▶ The drive torque of a pump stage is calculated as follows:

$$T = \frac{\Delta p \cdot V \cdot 0.0159}{\eta_{\text{hydr-mech}}}$$

Key

T	Torque T [Nm]
Δp	Operating pressure [bar]
V	Displacement [cm ³]
η	Hydraulic mechanical efficiency

▼ Maximum permissible torques [Nm]

Type	Drive torque			Output torque
	Parallel shaft E	Splined shaft R	Splined shaft S	
PGH2	100	80	155	75
PGH3	110	80	155	75

Installation instructions

Fluid tank

- ▶ Adjust the usable capacity of the tank to the operating conditions.
- ▶ The permissible fluid temperature must not be exceeded; provide a cooler if necessary.

Lines and ports

- ▶ Remove protective plug from the pump.
- ▶ Select the clear width of pipes according to the ports (suction speed 1 to 1.5 m/s).
- ▶ Inlet pressure see page 4
- ▶ Thoroughly clean pipelines and fittings prior to installing.

Proposal for piping layout

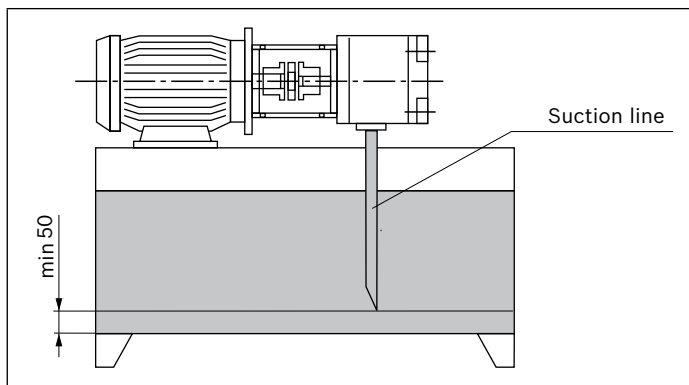

- ▶ Under no circumstances may returning fluid be drawn directly into the suction port again, i. e., select the largest possible distance between suction line and return line.
- ▶ The suction line and return tank line must always be clearly below the oil level.
- ▶ Ensure suction-tight installation of the pipelines.

Filter

If possible, use return-line filter or pressure filters.
(Only use suction filters in combination with a low pressure switch/ contamination indicator).

Hydraulic fluid

- ▶ Please observe our specification according to data sheet 90220.
- ▶ We recommend brand name hydraulic fluids.
- ▶ Different oil types must not be mixed together as this may result in decomposition and deterioration of the lubricity.
- ▶ The fluid must be changed at certain intervals depending on the operating conditions. This involves cleaning residues from the fluid reservoir.

Drive

Electric motor + pump support + coupling + pump

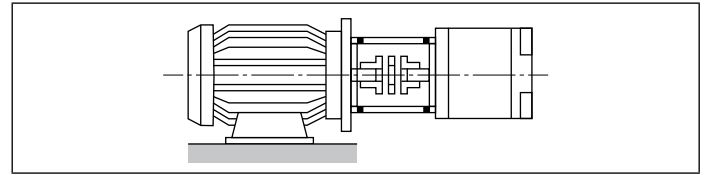

- ▶ No radial or axial forces permissible on the pump drive shaft!
- ▶ Motor and pump must be exactly aligned!
- ▶ Always use a coupling that is suitable for compensating shaft offsets!
- ▶ When installing the coupling, avoid axial forces, i. e. **do not hammer or press the coupling onto the shaft!** Use the female thread of the drive shaft!

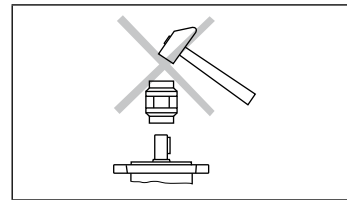

Installation positions

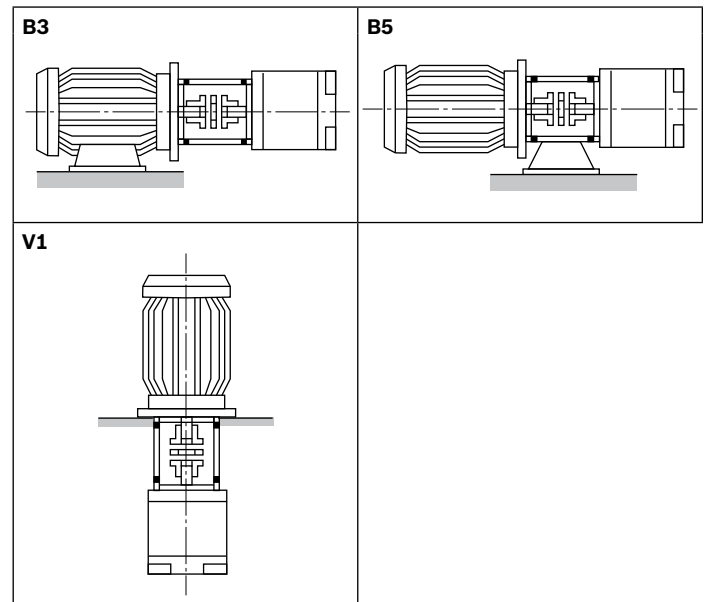

Commissioning instructions

Preparation

- ▶ Check whether the system is thoroughly and properly installed.
- ▶ Fill the hydraulic fluid only in through filters with the required minimum retention rate.
- ▶ Fill pump completely with fluid through suction and pressure line.
- ▶ Check the direction of rotation of the motor for compliance with the direction of rotation according to the pump type.

Air bleed

- ▶ Open the air bleeding port on the system by hand or change over to depressurized circulation in accordance with the instruction manual of the system. During air bleeding, the discharge of entrapped air must be ensured.
- ▶ To air bleed the pump, briefly switch the motor on and then switch it immediately off again (inching mode). Repeat this process until it is ensured that the pump has been completely air bled.
- ▶ Close the open air bleeding ports by hand.

Commissioning

- ▶ Once it is ensured that the pump has been completely air bled, switch on the motor. Let the pump run depressurized until the system is completely air bled. For air bleeding the system, observe the instruction manual for the system.
- ▶ Commission the system according to the instruction manual and let the pump run under load.
- ▶ After some time in operation, check the hydraulic fluid in the reservoir for bladders or the formation of foam on the surface.

Operation

- ▶ During operation, take note of changes in the noise emissions. A slight increase in the noise level is normal due to heating the operating medium. A significant increase in the noise level or brief, stochastic changes in the noise characteristics may indicate the aspiration of air. If suction lines are too short or fluid level not high enough air can also be primed in a swirl action.
- ▶ Changes in operating speeds, temperatures, increase in the noise level or power consumption indicate wear or damage to the system or pump.

Recommissioning

- ▶ Inspect the pump and system for leakage. Loss of oil indicates leakage below the hydraulic fluid level. An increased hydraulic fluid level in the reservoir indicates leakage above the hydraulic fluid level.
- ▶ If the pump is arranged above the hydraulic fluid level, the pump can drain due to leakages, for example due to a worn-out shaft seal ring. In this case, air bleeding is again required during recommissioning. Have the damage repaired.
- ▶ Air bleeding must again be performed following repair and maintenance work.
- ▶ Switch on the motor when the system is in flawless condition.

General

- ▶ Pumps delivered by us are tested for function and power. The warranty applies only to the delivered configuration.
- ▶ Repairs may only be performed by the manufacturer or his authorized dealers and subsidiaries. The entitlement to warranty cover will be rendered void if the product is incorrectly repaired, installed, commissioned or operated, or if it is used or handled improperly.
- ▶ Through opening, conversion or extension of the internal gear pump, the entitlement under warranty will be rendered void.

Notes

- ▶ Installation, maintenance and repair of the pump may only be carried out by authorized, trained and instructed personnel!
- ▶ The pump may only be operated at the permissible data (see pages 4).
- ▶ The pump may only be operated when in perfect condition!
- ▶ During all work on the pump, depressurize the system!
- ▶ Unauthorized conversions or changes that affect safety and function are not permissible!
- ▶ Mount safety devices (e.g., coupling protection) and do not remove any existing safety devices and equipment!
- ▶ Always ensure the proper fit of all mounting bolts! (Observe the specified tightening torques)
- ▶ The generally valid safety and accident prevention regulations must be observed!

Bosch Rexroth AG
Mobile Applications
Zum Eisengießer 1
97816 Lohr am Main, Germany
Tel. +49 9352 18-0
info.ma@boschrexroth.de
www.boschrexroth.com

© This document, as well as the data, specifications and other information set forth in it, are the exclusive property of Bosch Rexroth AG. It may not be reproduced or given to third parties without its consent. The data specified above only serve to describe the product. No statements concerning a certain condition or suitability for a certain application can be derived from our information. The information given does not release the user from the obligation of own judgment and verification. It must be remembered that our products are subject to a natural process of wear and aging.

Internal gear pump, fixed displacement

RE 10227/12.10
Replaces: 04.07

1/24

Type PGH

Frame size 4 and 5
 Component series: 3X
 Maximum operating pressure 350 bar
 Maximum displacement volume 250 cm³



H7417_d

Table of contents

Contents	Page
Features	1
Ordering code single pumps	2
Function, section, symbol	3
Technical data	4 and 5
Characteristic curves	On request
Unit dimensions single pumps	6 to 11
Ports	12
Pump combinations	13
Unit dimensions pump combinations	14 to 18
Project planning information	19 to 22
Commissioning notes	23

Features

- Fixed displacement
- Low operating noise
- Little flow pulsation
- High efficiency also at low speed and viscosity due to sealing gap compensation
- Suitable for broad viscosity and speed ranges
- All frame sizes and sizes can be combined with each other in any form
- Can be combined with internal gear pumps, vane pumps and axial piston pumps
- Suitable for operation with HFC fluid (seal design "W")
- Use:
For fatigue-resistant drives with high power and high pressures with very large load cycle numbers, e.g. plastics processing machines, automated presses, foundry machines and other applications with accumulator charging operation.

Information on available spare parts:
www.boschrexroth.com/spc

Ordering code: Single pumps

PG	H	-3X/						*
----	---	------	--	--	--	--	--	---

Series

High pressure pump

= H

Frame size

BG4

= 4

BG5

= 5

Component series: Component series 30 to 39 = **3X**
(30 to 39: Unchanged installation and connection dimensions)

Size	Size	Displacement/ revolution	
BG4	20	20.10 cm ³	= 020
	25	25.30 cm ³	= 025
	32	32.70 cm ³	= 032
	40	40.10 cm ³	= 040
	50	50.70 cm ³	= 050
BG5	63	64.70 cm ³	= 063
	80	81.40 cm ³	= 080
	100	100.20 cm ³	= 100
	125	125.30 cm ³	= 125
	160	162.80 cm ³	= 160
	200	200.40 cm ³	= 200
	250	250.50 cm ³	= 250

Further details in the plain text

Type of connection

U2 = SAE 2-hole mounting flange**E4** = ¹⁾ ISO 4-hole mounting flange according to ISO 3019-2 and VDMA 24560

Seal material

V = FKM seals**W** = ²⁾ Shaft seal ring made of NBR (remaining seals made of FKM)

Line connection ³⁾

07 = SAE flange standard pressure series**11** = SAE flange high-pressure series

Shaft design

E = Cylindrical**R** = SAE involute gear

Direction of rotation (looking at the shaft end)

R = Clockwise**L** = Counterclockwise (on request)

¹⁾ Only in connection with cylindrical shaft (according to VDMA), only with clockwise rotation

²⁾ In case of operation with HFC fluid

³⁾ For each size, one type of connection **07** or **11** has been determined:

07: PGH5-3X/200/250...**11**: PGH4-3X/020/025/032/040/050...

PGH5-3X/063/080/100/125/160...

The suction ports have all been designed in standard pressure series (dimensions see page 12).

Not all variants are possible according to the type key!
Please select the desired pump using the selection tables (pages 6 to 11) or after consultation with Bosch Rexroth.

Standard types PGH4-3X

Type	Material no.
PGH4-3X/020RE11VU2	R901147100
PGH4-3X/025RE11VU2	R901147101
PGH4-3X/032RE11VU2	R901147102
PGH4-3X/040RE11VU2	R901147103
PGH4-3X/050RE11VU2	R901147104

Standard types PGH5-3X

Type	Material no.
PGH5-3X/063RE11VU2	R901147115
PGH5-3X/080RE11VU2	R901147116
PGH5-3X/100RE11VU2	R901147117
PGH5-3X/125RE11VU2	R901147118
PGH5-3X/160RE11VU2	R901147119
PGH5-3X/200RE07VU2	R901147120
PGH5-3X/250RE07VU2	R901147121

Function, section, symbol

Structure

Hydraulic pumps of type PGH.-3X are gap-compensated internal gear pumps with fixed displacement.

They mainly consist of: Mounting flange (1), housing (2),

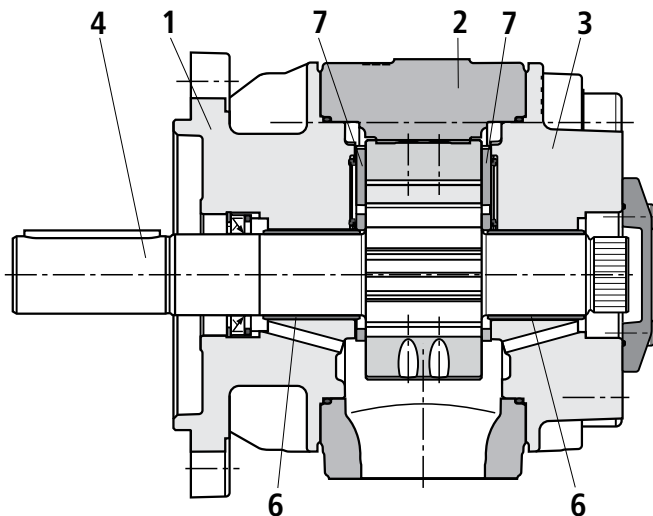

cover with through-drive (3), pinion shaft (4), internal gear (5), sliding bearings (6), axial washers (7) and stop pin (8) as well as the radial compensation consisting of segment (9), segment support (10) and the seal rolls (11).

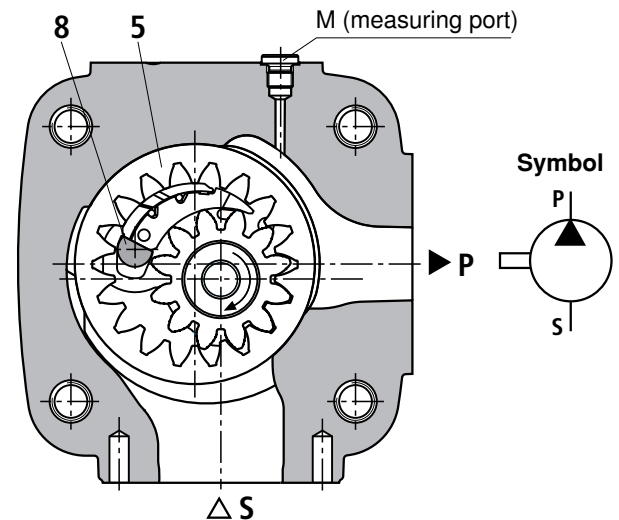

Suction and displacement procedure

The hydro-dynamically mounted pinion shaft (4) drives the toothed internal gear (5) in the direction of rotation shown.

The tooth clearances opening in the suction area prime the fluid. The fluid is transported into the tooth clearances of pinion and internal gear, from the suction area (S) into the pressure area (P).

There, the fluid is displaced from the closing tooth clearances and delivered into the pressure port (P).

Suction and discharge area are separated by the radial compensation elements (9 to 11) and the tooth engagement between internal gear and pinion shaft.

Axial compensation

The displacement chamber in the pressure area is axially sealed by axial washers (7).

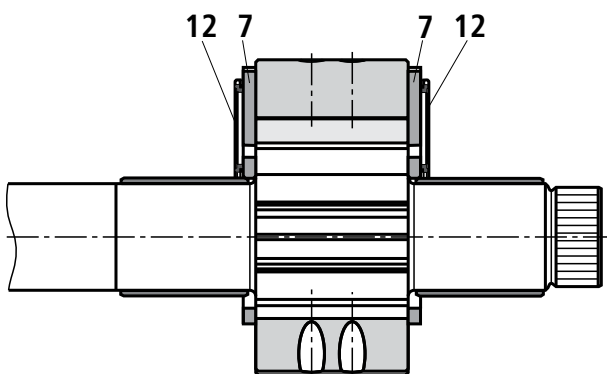

The sides of the axial washers facing away from the displacement area are backed by a pressure field (12). These fields balance the axial washers vis-à-vis the displacement area, which results in a perfect sealing with low mechanical losses.

Radial compensation

The radial compensation elements consist of segment (9), segment support (10) and seal rolls (11).

Segment (9) and segment support (10) are arranged in the pressure field so that the resulting compressive force is basically accepted by the stop pin.

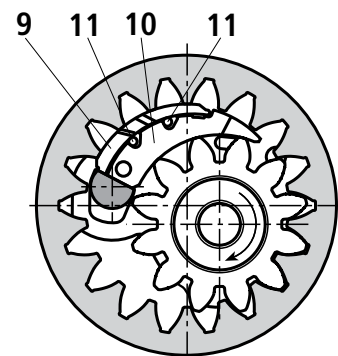

A small compressive force component presses segment and segment support onto the tooth tips of pinion shaft and internal gear and in this way provides for the separation of the pressure area from the suction area with automatic clearance adjustment.

This is the prerequisite for constantly high volumetric efficiency during the entire operating time.

The clearance adjustment of segment and segment support is made possible by the seal rolls located inbetween.

Hydro-dynamic and hydrostatic mounting

The pinion shaft (4) is accepted by hydro-dynamically lubricated radial sliding bearings (6).

The internal gear (5) is mounted hydrostatically in the housing.

Gearing

The gearing with involute edges has a large meshing length for little flow and pressure pulsation and thus guarantees low-noise running.

Technical Data (For applications outside these parameters, please consult us!)

general

Design	Internal gear pump, gap-compensated
Type of connection	SAE 2-hole flange according to ISO 3019-1 or 4-hole flange according to VDMA 24560 and ISO 3019-2
Line connection	Flange port
Shaft load	Radial and axial forces (e.g. belt pulley) only after coordination
Direction of rotation (looking at the shaft end)	Clockwise or counterclockwise (on request) – not bidirectional!

hydraulic

Hydraulic fluid	HLP – mineral oil according to DIN 51524 part 2 HFC – water polymer solutions according to DIN EN ISO 12922 ^{1) 2)} ; Seal design W HEES – fluids according to DIN ISO 15380 ¹⁾ HFD-U – fluids according to VDMA 24317 ¹⁾ , DIN EN ISO 12922 ¹⁾ Please observe our specifications according to data sheet RE 90220 Other fluids on request!		
Hydraulic fluid temperature range	HLP fluid	°C	-10 to +80; for other temperatures please consult us!
	Special fluid	°C	-10 to +50; for other temperatures please consult us!
Ambient temperature range		°C	-20 to +60
Viscosity range		mm ² /s	10 to 300 (to n = 1800 min ⁻¹) 10 to 100 (to n = 3000 min ⁻¹) 2000 admissible start viscosity (400 to 1800 min ⁻¹)
Max. admissible level of contamination of the hydraulic fluid cleanliness class according to ISO 4406 (c)			Class 20/18/15 ³⁾

1) Attention!

To these media, the limitations for special fluids apply

2) Hydraulic fluid HFC: Input speed $n_{\max} = 2000 \text{ min}^{-1}$

3) The cleanliness classes specified for the components must be adhered to in hydraulic systems. Efficient filtration prevents failures and simultaneously increases the service life of the components.

For the selection of filters, see data sheets RE 50070, RE 50076, RE 50081, RE 50086 and RE 50088.

Technical Data (For applications outside these parameters, please consult us!)

Frame size		Frame size	PGH4						
Size	Size		20	25	32	40	50		
Weight	<i>m</i>	kg	14	14.5	15	16	17		
Speed range ¹⁾	n_{min}	min ⁻¹	200	200	200	200	200		
	n_{max}	min ⁻¹	3000	3000	3000	3000	3000		
Displacement	<i>V</i>	cm ³	20.1	25.3	32.7	40.1	50.7		
Flow ²⁾	q_V	l/min	28.9	36.3	46.9	57.6	72.8		
Moment of inertia (around drive axis)	<i>J</i>	kgm ²	0.00037	0.00045	0.00055	0.00066	0.00081		
Power consumption	P_{ad}	kW							
Min. drive power necessary (with $p \approx 1$ bar)			1.1	1.1	1.1	1.1	1.5		
Max. admissible drive power			35	44	56	61	76		
Operating pressure, absolute – Input			0.8 to 2 (shortly, upon start 0.6 bar)						
Nominal pressure – Output, continuous	p_N	bar							
	HLP fluid		315				250		
		Special fluid ³⁾	220				175		
intermittent ⁴⁾	p_{max}	bar							
	HLP fluid		350				315		
	Special fluid ³⁾		245				210		
Frame size		Frame size	PGH5						
Size	Size		63	80	100	125	160	200	250
Weight	<i>m</i>	kg	42	43.5	45.5	48	52	55.5	60.5
Speed range ¹⁾	n_{min}	min ⁻¹	200	200	200	200	200	200	200
	n_{max}	min ⁻¹	3000	3000	3000	3000	3000	3000	3000
Displacement	<i>V</i>	cm ³	64.7	81.4	100.2	125.3	162.8	200.4	250.5
Flow ²⁾	q_V	l/min	92.8	116.9	143.8	179.8	233.7	287.7	359.6
Moment of inertia (around drive axis)	<i>J</i>	kgm ²	0.00237	0.00289	0.00329	0.00407	0.00506	0.00623	0.00760
Power consumption	P_{ad}	kW							
Min. drive power necessary (with $p \approx 1$ bar)			1.8	2.2	3	4	5.5	7.5	7.5
Max. admissible drive power			96	103	129	161	134	140	134
Operating pressure, absolute – Input			0.8 to 2 (shortly, upon start 0.6 bar)						
Nominal pressure – Output, continuous	p_N	bar							
	HLP fluid		315				210	170	135
		Special fluid ³⁾	220				145	115	90
intermittent ⁴⁾	p_{max}	bar							
	HLP fluid		350				260	210	170
	Special fluid ³⁾		245				180	145	115

¹⁾ Hydraulic fluid HFC: Input speed $n_{max} = 2000$ min⁻¹

²⁾ Measured with $n = 1450$ min⁻¹, $p = 10$ bar and $\dot{V} = 30$ mm²/s

³⁾ **Attention!**

To these media, the limitations for special fluids apply

⁴⁾ Max 10 s, max. 50 % of the duty cycle

Unit dimensions of frame size 4 (dimensions in mm [inch])

PGH4-3X/...^RE...VU2
_L

Drive shaft cylindrical,
 SAE 2-hole mounting flange

Type	Size	Material no.	"L" counter-clockwise	L1	L2	L3	S ¹⁾	P ¹⁾
PGH4-3X/020..E11VU2		R901147100	On request	145 [5.71]	70.5 [2.78]	129 [5.08]	1" S	3/4" H
PGH4-3X/025..E11VU2		R901147101	On request	150 [5.91]	73 [2.87]	134 [5.28]	1 1/4" S	3/4" H
PGH4-3X/032..E11VU2		R901147102	On request	157 [6.18]	76.5 [3.01]	141 [5.55]	1 1/2" S	1" H
PGH4-3X/040..E11VU2		R901147103	On request	164 [6.46]	80 [3.15]	148 [5.83]	1 1/2" S	1" H
PGH4-3X/050..E11VU2		R901147104	On request	174 [6.85]	85 [3.35]	158 [6.22]	2" S	1" H

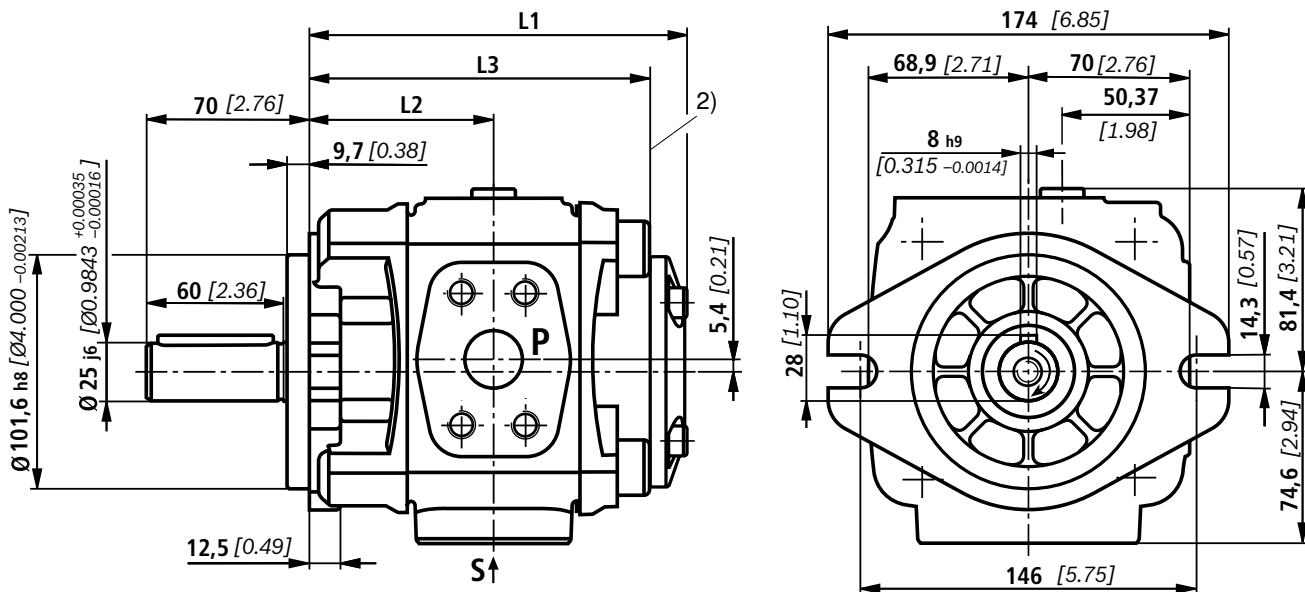

¹⁾ S = Standard pressure series;
 H = High-pressure series;
 exact dimensions see table page 12

²⁾ For multiple pumps, the combination part starts from here

The figure shows a pump with clockwise rotation, in case of pumps with counterclockwise rotation, the pressure port is on the opposite side!

Unit dimensions of frame size 4 (dimensions in mm [inch])

PGH4-3X/... RE...VE4

Drive shaft cylindrical,
4-hole mounting flange according to ISO 3019-2
and VDMA 24560

Type	Size	Material no. "R" clockwise	L1	L2	L3	S ¹⁾	P ¹⁾
PGH4-3X/020RE11VE4		R901147105	145 [5.71]	70.5 [2.78]	129 [5.08]	1" S	3/4" H
PGH4-3X/025RE11VE4		R901147106	150 [5.91]	73.0 [2.87]	134 [5.28]	1 1/4" S	3/4" H
PGH4-3X/032RE11VE4		R901147107	157 [6.18]	76.5 [3.01]	141 [5.55]	1 1/2" S	1" H
PGH4-3X/040RE11VE4		R901147108	164 [6.46]	80 [3.15]	148 [5.83]	1 1/2" S	1" H
PGH4-3X/050RE11VE4		R901147109	174 [6.85]	85 [3.35]	158 [6.22]	2" S	1" H

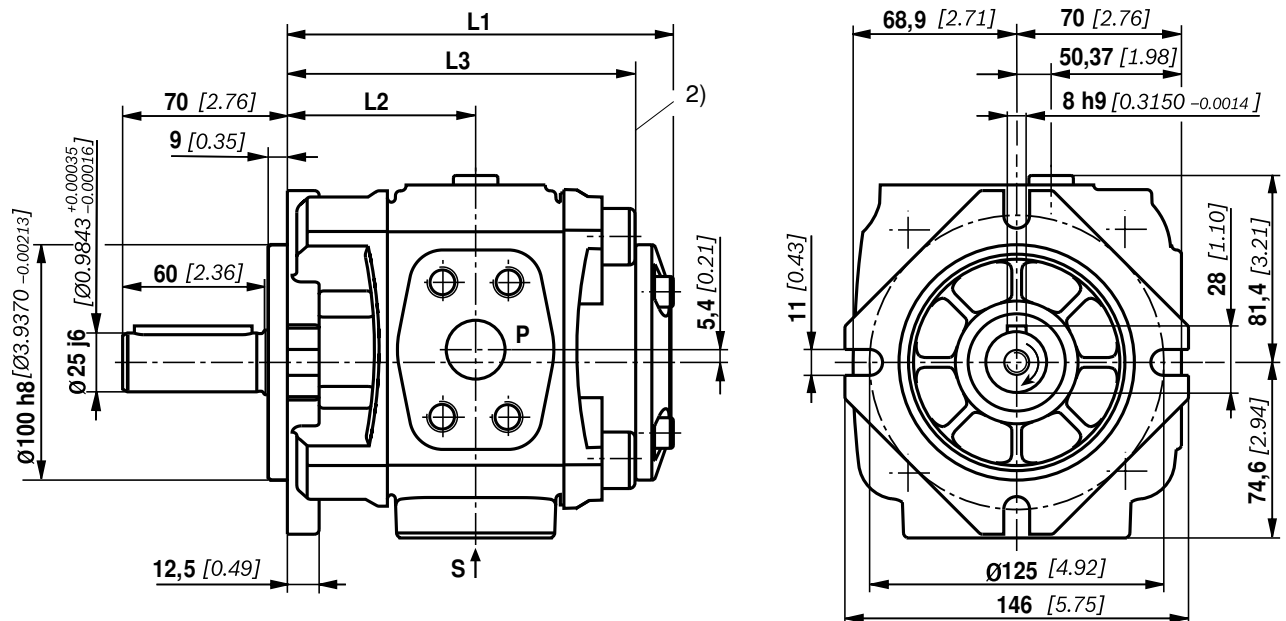

¹⁾ S = Standard pressure series;
H = High-pressure series;
exact dimensions see table page 12

²⁾ For multiple pumps, the combination part starts from here

Unit dimensions of frame size 4 (dimensions in mm [inch])

PGH4-3X/..._LR...VU2

Drive shaft splined, SAE 2-hole mounting flange

(central and back pump in pump combinations)

Type	Size	Material no.		L1	L2	L3	S ¹⁾	P ¹⁾
		"R" clockwise	"L" counter-clockwise					
PGH4-3X/020..R11VU2		R901147110	On request	145 [5.71]	70.5 [2.78]	129 [5.08]	1" S	3/4" H
PGH4-3X/025..R11VU2		R901147111	On request	150 [5.91]	73 [2.87]	134 [5.28]	1 1/4" S	3/4" H
PGH4-3X/032..R11VU2		R901147112	On request	157 [6.18]	76.5 [3.01]	141 [5.55]	1 1/2" S	1" H
PGH4-3X/040..R11VU2		R901147113	On request	164 [6.46]	80 [3.15]	148 [5.83]	1 1/2" S	1" H
PGH4-3X/050..R11VU2		R901147114	On request	174 [6.85]	85 [3.35]	158 [6.22]	2" S	1" H

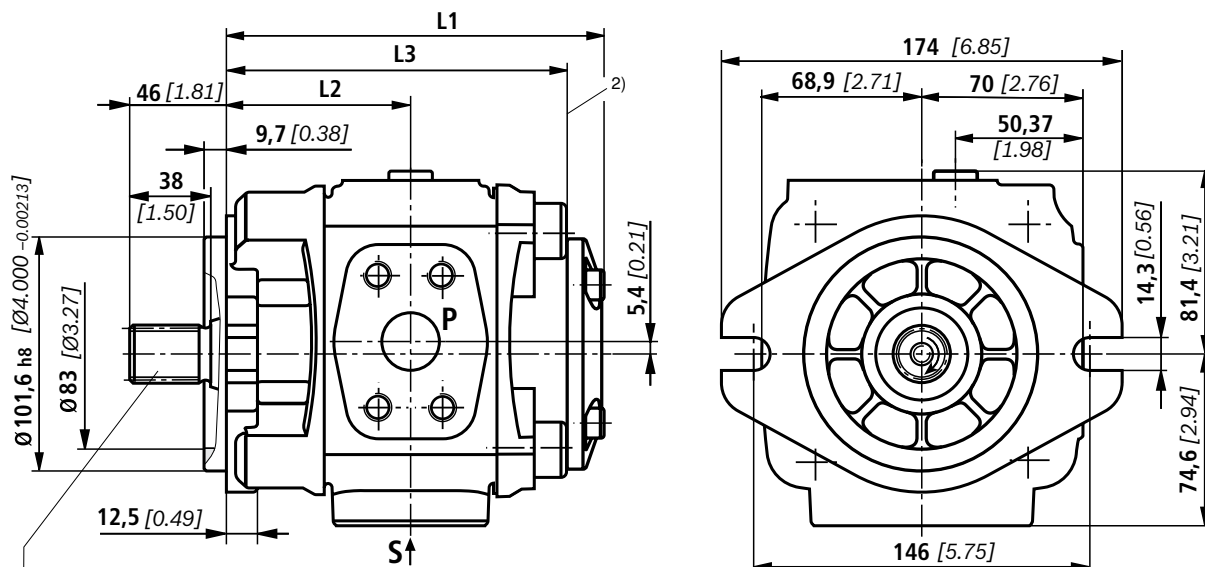

Shaft 25-4; SAE J744 JUL 88;

Involute gear

ANSI B92.1a-1976,

15T 16/32 DP 30°

¹⁾ S = Standard pressure series;
H = High-pressure series;
exact dimensions see table page 12

²⁾ For pump combinations, the combination part starts from here

The figure shows a pump with clockwise rotation, in case of pumps with counterclockwise rotation, the pressure port is on the opposite side!

Unit dimensions of frame size 5 (dimensions in mm [inch])

PGH5-3X/... R E...VU2
L

Drive shaft cylindrical, SAE 2-hole mounting flange

Type	Size	Material no.		L1	L2	L3	S ¹⁾	P ¹⁾
		"R" clockwise	"L" counter-clockwise					
PGH5-3X/063..E11VU2		R901147115	On request	210 [8.27]	105.5 [4.15]	194 [7.64]	2" S	1 1/4" H
PGH5-3X/080..E11VU2		R901147116	On request	218 [8.58]	109.5 [4.31]	202 [7.95]	2" S	1 1/4" H
PGH5-3X/100..E11VU2		R901147117	On request	227 [8.94]	114 [4.49]	211 [8.31]	2 1/2" S	1 1/2" H
PGH5-3X/125..E11VU2		R901147118	On request	239 [9.41]	120 [4.72]	223 [8.78]	2 1/2" S	1 1/2" H
PGH5-3X/160..E11VU2		R901147119	On request	257 [10.12]	129 [5.08]	241 [9.49]	3" S	2" H
PGH5-3X/200..E07VU2		R901147120	On request	275 [10.83]	138 [5.43]	259 [10.20]	3 1/2" S	2" S
PGH5-3X/250..E07VU2		R901147121	On request	299 [11.77]	150 [5.91]	283 [11.14]	3 1/2" S	2 1/2" S

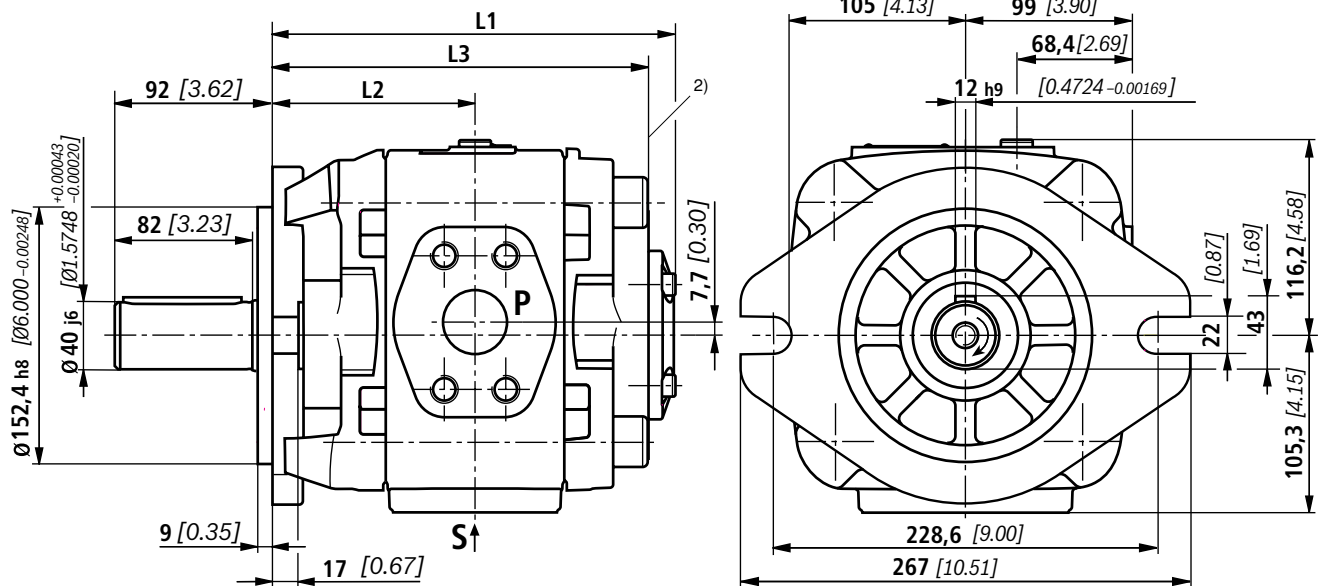

¹⁾ S = Standard pressure series;
H = High-pressure series;
exact dimensions see table page 12

²⁾ For pump combinations, the combination part starts from here

The figure shows a pump with clockwise rotation, in case of pumps with counterclockwise rotation, the pressure port is on the opposite side!

Unit dimensions of frame size 5 (dimensions in mm [inch])

PGH5-3X/...RE...VE4

Drive shaft cylindrical,
4-hole mounting flange according to ISO 3019-2
and VDMA 24560

Type	Size	Material no. "R" clockwise	L1	L2	L3	S ¹⁾	P ¹⁾
PGH5-3X/063RE11VE4		R901147122	210 [8.27]	105.5 [4.15]	194 [7.64]	2" S	1 1/4" H
PGH5-3X/080RE11VE4		R901147123	218 [8.58]	109.5 [4.31]	202 [7.95]	2" S	1 1/4" H
PGH5-3X/100RE11VE4		R901147124	227 [8.94]	114 [4.49]	211 [8.31]	2 1/2" S	1 1/2" H
PGH5-3X/125RE11VE4		R901147125	239 [9.41]	120 [4.72]	223 [8.78]	2 1/2" S	1 1/2" H
PGH5-3X/160RE11VE4		R901147126	257 [10.12]	129 [5.08]	241 [9.49]	3" S	2" H
PGH5-3X/200RE07VE4		R901147127	275 [10.83]	138 [5.43]	259 [10.20]	3 1/2" S	2" S
PGH5-3X/250RE07VE4		R901147128	299 [11.77]	150 [5.91]	283 [11.14]	3 1/2" S	2 1/2" S

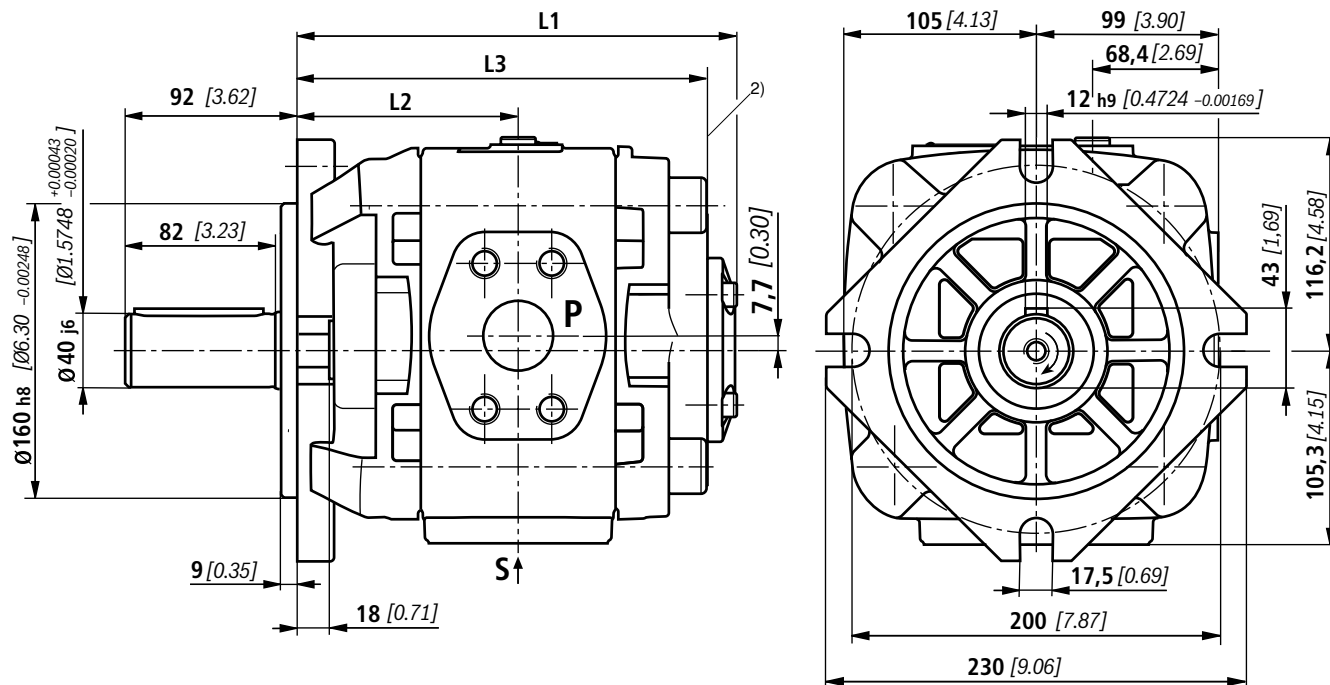

¹⁾ S = Standard pressure series;
H = High-pressure series;
exact dimensions see table page 12
²⁾ For pump combinations, the combination part starts from here

Unit dimensions of frame size 5 (dimensions in mm [inch])

PGH5-3X/...^R_L...VU2

Drive shaft splined, SAE 2-hole mounting flange

(central and back pump for pump combinations)

Type	Size	Material no.		L1	L2	L3	S ¹⁾	P ¹⁾
		"R" clockwise	"L" counter-clockwise					
PGH5-3X/063..R11VU2		R901147129	On request	219 [8.62]	114.5 [4.51]	203 [7.99]	2" S	1 1/4" H
PGH5-3X/080..R11VU2		R901147130	On request	227 [8.94]	118.5 [4.67]	211 [8.31]	2" S	1 1/4" H
PGH5-3X/100..R11VU2		R901147131	On request	236 [9.29]	123 [4.84]	220 [8.66]	2 1/2" S	1 1/2" H
PGH5-3X/125..R11VU2		R901147132	On request	248 [9.76]	129 [5.08]	232 [9.13]	2 1/2" S	1 1/2" H
PGH5-3X/160..R11VU2		R901147133	On request	266 [10.47]	138 [5.43]	250 [9.84]	3" S	2" H
PGH5-3X/200..R07VU2		R901147134	On request	284 [11.18]	147 [5.79]	268 [10.55]	3 1/2" S	2" S
PGH5-3X/250..R07VU2		R901147135	On request	308 [12.13]	159 [6.26]	292 [11.50]	3 1/2" S	2 1/2" S

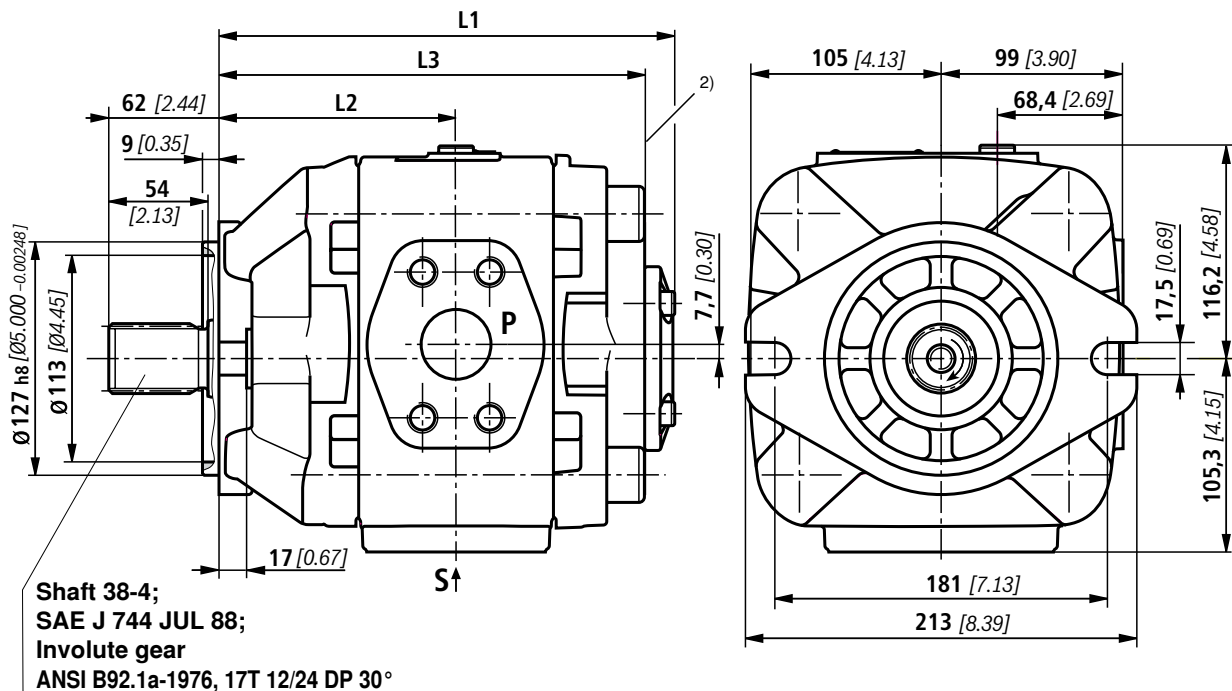

¹⁾ S = Standard pressure series;
H = High-pressure series;
exact dimensions see table page 12

²⁾ For pump combinations, the combination part starts from here

The figure shows a pump with clockwise rotation, in case of pumps with counterclockwise rotation, the pressure port is on the opposite side!

Ports (dimensions in mm [inch])

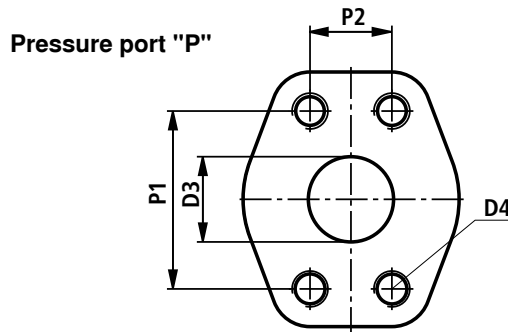
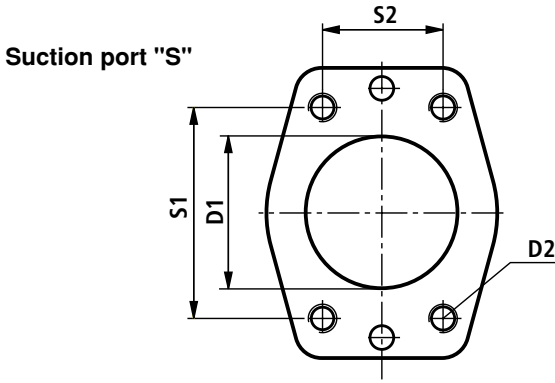

Frame size	Size	Porting pattern/ suction port S	D1	D2	S1	S2	Porting pattern/ pressure port P	D3	D4	P1	P2
4	020	1" 5000 PSI	Ø25 [Ø0.984]	M10; 18	52.4 [2.063]	26.2 [1.032]	3/4" 6000 PSI	Ø19 [Ø0.748]	M10; 18	50.8 [2.000]	23.8 [0.937]
	025	1 1/4" 4000 PSI	Ø32 [Ø1.260]	M10; 18	58.7 [2.311]	30.2 [1.189]	3/4" 6000 PSI	Ø19 [Ø0.748]	M10; 18	50.8 [2.000]	23.8 [0.937]
	032	1 1/2" 3000 PSI	Ø38 [Ø1.496]	M12; 21	69.9 [2.752]	35.7 [1.406]	1" 6000 PSI	Ø25.4 [Ø1.000]	M12; 23	57.2 [2.252]	27.8 [1.094]
	040	1 1/2" 3000 PSI	Ø38 [Ø1.496]	M12; 21	69.9 [2.752]	35.7 [1.406]	1" 6000 PSI	Ø25.4 [Ø1.000]	M12; 23	57.2 [2.252]	27.8 [1.094]
	050	2" 3000 PSI	Ø51 [Ø2.008]	M12; 21	77.8 [3.063]	42.9 [1.689]	1" 6000 PSI	Ø25.4 [Ø1.000]	M12; 23	57.2 [2.252]	27.8 [1.094]
5	063	2" 3000 PSI	Ø51 [Ø2.008]	M12; 21	77.8 [3.063]	42.9 [1.689]	1 1/4" 6000 PSI	Ø32 [Ø1.260]	M12; 21	66.6 [2.622]	31.8 [1.252]
	080	2" 3000 PSI	Ø51 [Ø2.008]	M12; 21	77.8 [3.063]	42.9 [1.689]	1 1/4" 6000 PSI	Ø32 [Ø1.260]	M12; 21	66.6 [2.622]	31.8 [1.252]
	100	2 1/2" 2500 PSI	Ø64 [2.520]	M12; 23	88.9 [3.500]	50.8 [2.000]	1 1/2" 6000 PSI	Ø38 [Ø1.496]	M16; 30	79.3 [3.122]	36.5 [1.437]
	125	2 1/2" 2500 PSI	Ø64 [2.520]	M12; 23	88.9 [3.500]	50.8 [2.000]	1 1/2" 6000 PSI	Ø38 [Ø1.496]	M16; 30	79.3 [3.122]	36.5 [1.437]
	160	3" 2000 PSI	Ø76 [Ø2.992]	M16; 30	106.4 [4.189]	61.9 [2.437]	2" 6000 PSI	Ø51 [Ø2.008]	M20; 35	96.8 [3.811]	44.5 [1.752]
	200	3 1/2" 500 PSI	Ø89 [Ø3.504]	M16; 30	120.7 [4.752]	69.9 [2.752]	2" 3000 PSI	Ø51 [Ø2.008]	M12; 23	77.8 [3.063]	42.9 [1.689]
	250	3 1/2" 500 PSI	Ø89 [Ø3.504]	M16; 30	120.7 [4.752]	69.9 [2.752]	2 1/2" 2500 PSI	Ø64 [Ø2.520]	M12; 23	88.9 [3.500]	50.8 [2.000]

**Measuring port
PGH4-3X/... and PGH5-3X/...**

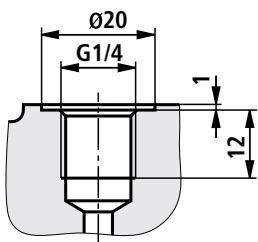

Transport thread PGH4-3X/...

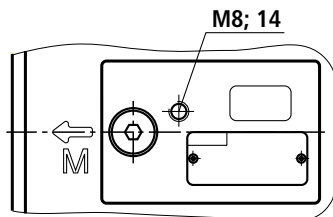

Transport thread PGH5-3X/...

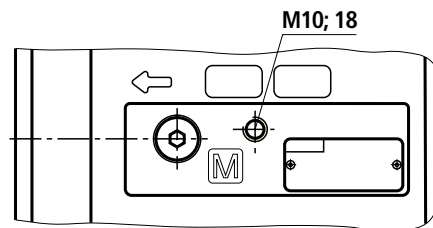

Pump combinations

All internal gear pumps of type PGH-3X can be combined; each pump has an output shaft gearing. The combination options and the material numbers of the necessary combination parts are shown in the following figure.

Please observe the project planning information for pump combinations on page 21.

Back pump \ Front pump	Material no.	
	PGH4-3X	PGH5-3X
PGH2-2X/...R...U2 (RE10223)	R901155288	R901155283
PGH3-2X/...R...U2 (RE10223)	R901155288	R901155283
PGH4-3X/...R...U2	R901155289	R901155284
PGH5-3X/...R...U2	–	R901155285
PGF2-2X/...J...U2 (RE10213)	R901155288	R901155283
PGP2-2X/...J...U2 (RE10231)	R901155288	R901155283
PGF3-3X/...J...U2 (RE10213)	R901155287	R901155282
PGP3-3X/...J...U2 (RE10231)	R901155287	R901155282
PVV/Q1-1X/...J...B (RE10335)	R901155287	R901155282
PVV/Q2-1X/...J...B (RE10335)	R901155287	R901155282
PVV/Q4-1X/...J...C (RE10335)	–	R901155286
PVV/Q5-1X/...J...C (RE10335)	–	R901155286
AZPF-1X/...RR...B (RE10089)	R901155288	R901155283

Ordering code

2-fold

= P2

3-fold

= P3

Series of the 1st pump ¹⁾

Component series of the 1st pump ¹⁾

Size of the 1st pump ¹⁾

Series of the 2nd pump ¹⁾

Component series of the 2nd pump ¹⁾

Size of the 2nd pump ¹⁾

Series of the 3rd pump ¹⁾

Component series of the 3rd pump ¹⁾

Size of the 3rd pump ¹⁾

Type of connection of the 1st pump

U2 = ²⁾ SAE 2-hole mounting flange

E4 = ³⁾ ISO 4-hole mounting flange according to ISO 3019-2 and VDMA 24560

Seal material

V = FKM seals

W = Shaft seal NBR (remaining seals FKM)

Shaft design of the 1st pump

E = Cylindrical

R = SAE involute gear

Direction of rotation (looking at the shaft end)

R = Clockwise

L = Counterclockwise (on request)

Order example:

P3GH5-3X/160+GH5-3X/100+GH4-3X/050REVE4

¹⁾ For detailed information refer to the ordering code page 2

²⁾ In connection with cylindrical and splined shaft

³⁾ Only in connection with cylindrical shaft (according to VDMA); only with clockwise rotation

Unit dimensions pump combinations (dimensions in mm [inch])

The dimensional drawings show the front pump and the combination part.

Combination part PGH5-3X+GF3-3X/VV1-1X/VV2-1X/K02

Material no.: R901155282

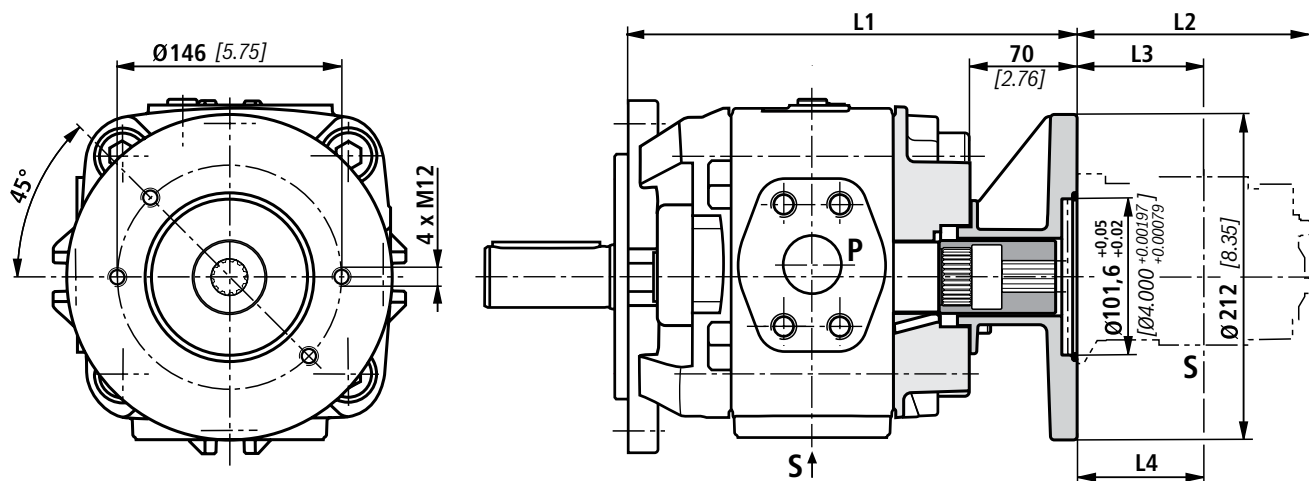

PGH5-3X.. Size	PGH5-3X/..RE..U2 PGH5-3X/..RE..E4 L1	PGH5-3X/..RR..U2 L1
63	264 [10.39]	273 [10.75]
80	272 [10.71]	281 [11.06]
100	281 [11.06]	290 [11.42]
125	293 [11.54]	302 [11.89]
160	311 [12.24]	320 [12.60]
200	329 [12.95]	338 [13.31]
250	353 [13.90]	362 [14.25]

PGF3/PGP2 Size	L2	L3
20	144.5 [5.69]	79.5 [3.13]
22	146.5 [5.77]	80.5 [3.17]
25	150.5 [5.93]	82.5 [3.25]
32	159.5 [6.28]	87 [3.43]
40	169.5 [6.67]	92 [3.62]

PVV..UMB Frame size	L2	L3 (P)	L4 (S)
1	156 [6.14]	133 [5.24]	63.5 [2.50]
2	163 [6.42]	38 [1.50]	120.5 [4.75]

Unit dimensions pump combinations (dimensions in mm [*inch*])

The dimensional drawings show the front pump and the combination part.

Combination part PGH5-3X+GH2/3-2X/GF2-2X/AZPF-1X/K01

Material no.: R901155283

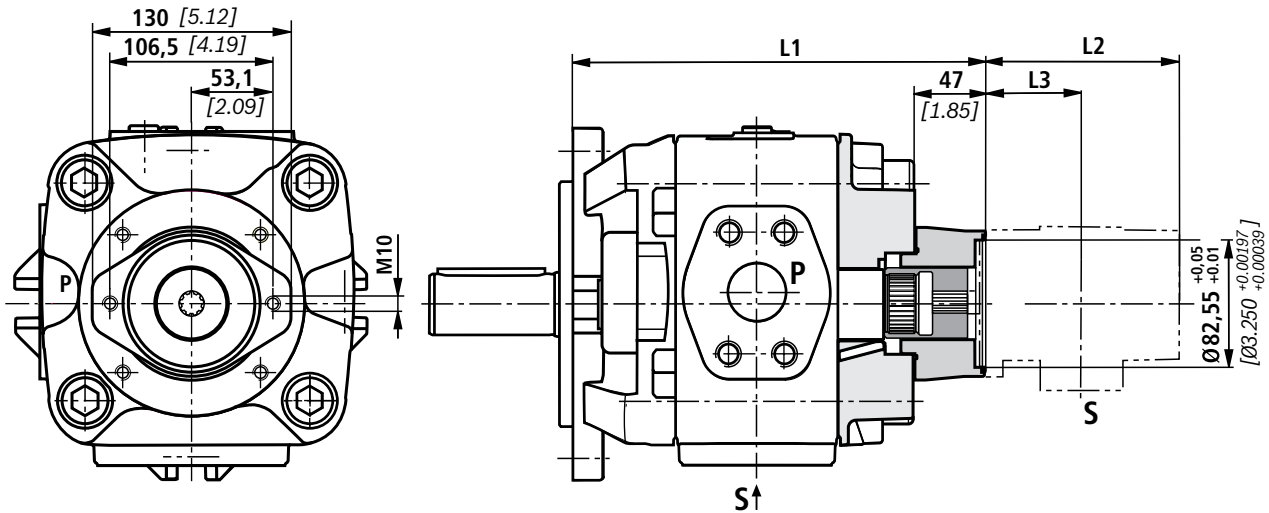

PGH5-3X.. Size	PGH5-3X/..RE..U2 PGH5-3X/..RE..E4 L1	PGH5-3X/..RR..U2 L1
63	241 [9.49]	250 [9.84]
80	249 [9.80]	258 [10.16]
100	258 [10.16]	267 [10.51]
125	270 [10.63]	279 [10.98]
160	288 [11.34]	297 [11.69]
200	306 [12.05]	315 [12.40]
250	330 [12.99]	339 [13.35]

PGH2 Size	L2	L3
005	110 [4.33]	54 [2.13]
006	112.5 [4.43]	55.5 [2.19]
008	116 [4.57]	57 [2.24]

PGH3 Size	L2	L3
011	121.5 [4.78]	60 [2.36]
013	126.5 [4.98]	62.5 [2.46]
016	131.5 [5.18]	65 [2.56]

PGF2/PGP2 Size	L2	L3
006	116 [4.567]	65 [2.559]
008	119.5 [4.705]	67 [2.638]
011	125 [4.921]	69.5 [2.736]
013	130 [5.118]	72 [2.835]
016	135 [5.315]	74.5 [2.933]
019	141 [5.551]	77.5 [3.051]
022	147 [5.787]	80.5 [3.169]

AZPF Size	L2	L3
004	85 [3.346]	40 [1.575]
005	87.5 [3.445]	41 [1.614]
008	91.5 [3.602]	43 [1.692]
011	96.5 [3.799]	47 [1.850]
014	101.5 [3.996]	47.5 [1.870]
016	105 [4.134]	47.5 [1.870]
019	110 [4.331]	47.5 [1.870]
022	115.5 [4.547]	55 [2.165]

Unit dimensions pump combinations (dimensions in mm [inch])

The dimensional drawings show the front pump and the combination part.

Combination part PGH5-3X+GH4-3X..R

Material no.: R901155284

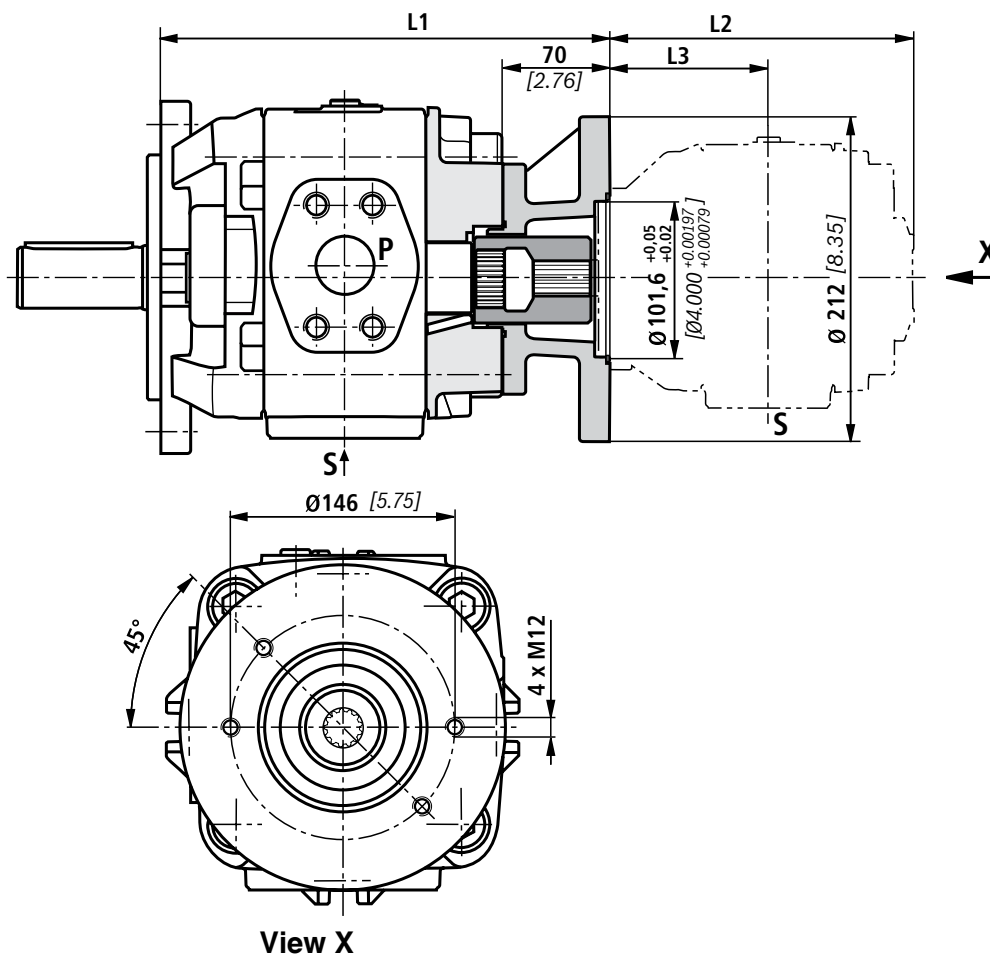

PGH5-3X.. Size	PGH5-3X/..RE..U2 PGH5-3X/..RE..E4 L1	PGH5-3X/..RR..U2 L1
63	264 [10.39]	273 [10.75]
80	272 [10.71]	281 [11.06]
100	281 [11.06]	290 [11.42]
125	293 [11.54]	302 [11.89]
160	311 [12.24]	320 [12.60]
200	329 [12.95]	338 [13.31]
250	353 [13.90]	362 [14.25]

PGH4-3X...R..U2 Size	L2	L3
20	145 [5.71]	70.5 [2.78]
25	150 [5.91]	73 [2.87]
32	157 [6.18]	76.5 [3.01]
40	164 [6.46]	80 [3.15]
50	174 [6.85]	85 [3.35]

Unit dimensions pump combinations (dimensions in mm [inch])

The dimensional drawings show the front pump and the combination part.

Combination part PGH5-3X+GH5-3X..R

Material no.: R901155285

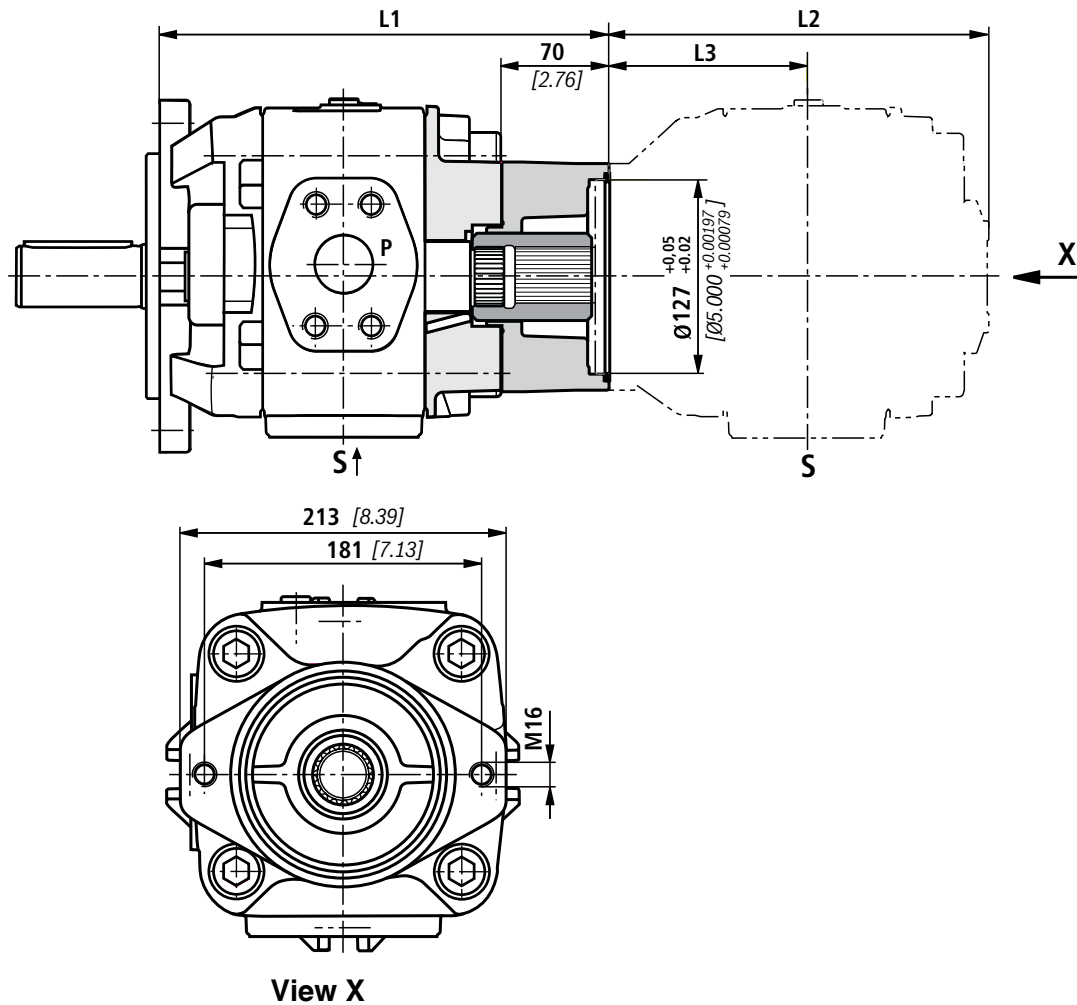

PGH5-3X.. Size	PGH5-3X/..RE..U2	PGH5-3X/..RR..U2
	PGH5-3X/..RE..E4 L1	L1
63	264 [10.39]	273 [10.75]
80	272 [10.71]	281 [11.06]
100	281 [11.06]	290 [11.42]
125	293 [11.54]	302 [11.89]
160	311 [12.24]	320 [12.60]
200	329 [12.95]	338 [13.31]
250	353 [13.90]	362 [14.25]

PGH5-3X...R..U2 Size	L2	L3
	63	219 [8.62]
80	227 [8.94]	118.5 [4.67]
100	236 [9.29]	123 [4.84]
125	248 [9.76]	129 [5.08]
160	266 [10.47]	138 [5.43]
200	284 [11.18]	147 [5.79]
250	308 [12.13]	159 [6.26]

Unit dimensions pump combinations (dimensions in mm [inch])

The dimensional drawings show the front pump and the combination part.

Combination part: PGH5-3X+VV4/5-1X..J

Material no. R901155286

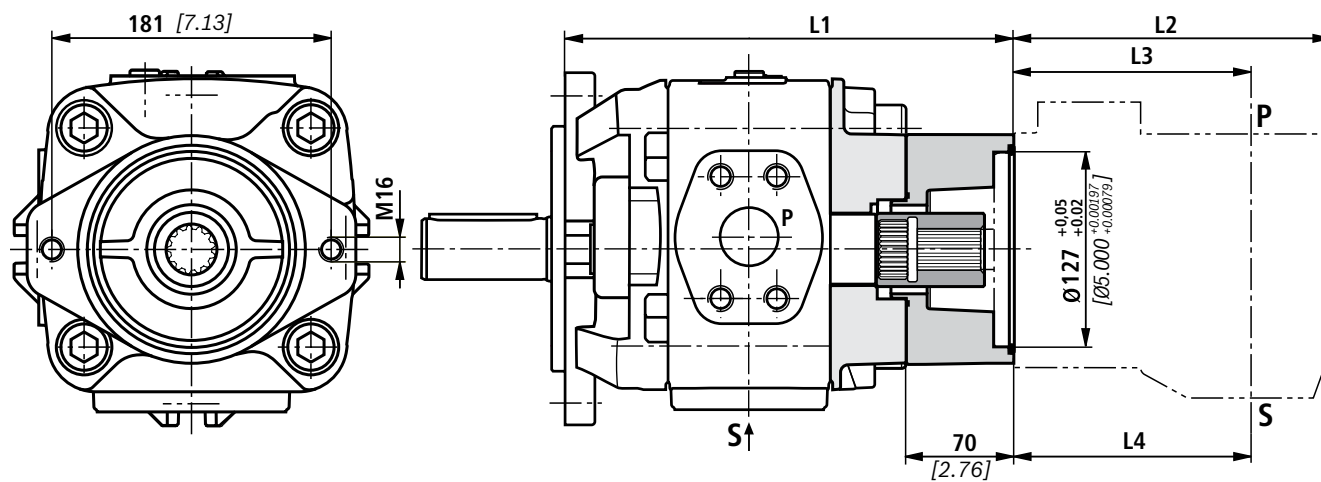

PGH5-3X.. Size	PGH5-3X/..RE..U2 PGH5-3X/..RE..E4 L1	PGH5-3X/..RR..U2 L1
63	264 [10.39]	273 [10.75]
80	272 [10.71]	281 [11.06]
100	281 [11.06]	290 [11.42]
125	293 [11.54]	302 [11.89]
160	311 [12.24]	320 [12.60]
200	329 [12.95]	338 [13.31]
250	353 [13.90]	362 [14.25]

PVV..UMB Frame size	L2	L3 (P)	L4 (S)
4	186 [7.32]	38 [1.50]	126 [4.96]
5	216 [8.50]	43 [1.69]	153 [6.02]

Project planning information

1. General notes

This project planning information refers to the specific properties of the Rexroth PGH.-3X internal gear pump.

Comprehensive general information and suggestions are contained in the hydraulics trainer, edition 3 "Project planning information and design of hydraulic systems", RE 00281.

1.1 Intended use

Rexroth internal gear pumps are intended for the setup of hydraulic drive systems in the fields of machine and plant construction. During project planning, the basic principles of the EU Machinery Directive or comparable national regulations outside the EU have to be observed.

The pumps must not be used in explosive environments in accordance with directive 94/9/EC (ATEX).

1.2 Technical data

The system or machine manufacturer has to ensure compliance with the admissible technical data and operating conditions. The pump itself does not contain a device to prevent operation outside the admissible data.

All mentioned technical features are average values and are applicable for the specified boundary conditions. In case of modifications to the boundary conditions (e.g. viscosity), the technical data may change as well. Tolerances corresponding to the relevant state-of-the-art are possible.

Operating the pump outside of the admissible technical data (pages 4, 5) is possible to a certain extent, however, this requires the explicit written approval by Bosch Rexroth.

2.2 Suction line

The line cross-sections have to be dimensioned for the designed flows in a manner that an ideal suction speed of 0.6 to 1.2 m/s is achieved on average. The suction speed must not exceed a maximum value of 2 m/s.

The suction cross-sections at the pump itself are dimensioned for the maximum flow and thus are a reference only. In case of continuous operation with speeds lower than the admissible maximum speed, the suction tube diameter is to be dimensioned smaller than the suction port of the pump in accordance with the actual suction speed.

All in all, the suction line has to be designed in a way that the admissible inlet operating pressure is complied with (0.8 to 2 bar absolute)! Bends and a combination of the suction tubes of several pumps must be avoided. If suction filters have to be used, it has to be ensured on the system side that the lowest admissible inlet operating pressure is not exceeded even when the filter is contaminated.

Please ensure air tightness of the transitions and dimensional stability of the suction hose as regards to the external air pressure.

The suction tube immersion depth should be selected as large as possible. Depending on the internal reservoir pressure, the viscosity of the operating medium, and the flow ratios within the reservoir, no vortex must be formed even during maximum flow. Otherwise there is the risk of sucking in air.

We recommend selecting suction tubes according to AB 23-03.

2. Hydraulic project planning

2.1 Bleeding option for commissioning

For Rexroth internal gear pumps PGH.-3X a manual, switchable or automatic bleeding option is to be provided for the initial commissioning or re-commissioning after maintenance and repair works. As bleeding point, the measurement port (M) available at the pump can be used. Otherwise, the bleeding point has to be put into the pressure line in front of the first valve or check valve. Bleeding may be effected with a maximum counter-pressure of 0.2 bar.

Examples of bleedings circuits:

1. Automatic bleeding via automatic bleeding valve
2. Switchable bleeding
3. Manually operated bleeding

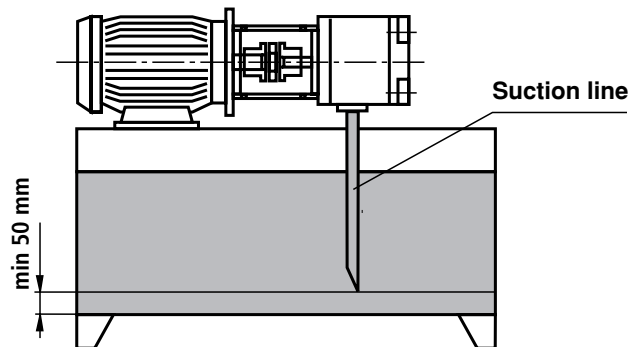
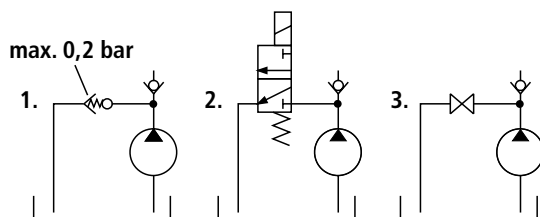

Project planning information

2.3 Pressure line

With pressure lines, sufficient bursting resistance of the tubes, hoses and connection elements has to be ensured. The cross-sections should be based on the maximum flow in order to avoid additional excessive load of the pump due to backpressure. In this connection, you must also consider the pipe losses across the entire pressure line length and other line resistances (e.g. bends, pressure filters).

2.4 Pressure limitation

The internal gear pump PGH is not equipped with devices for compliance with the maximum operating pressure. Setting and limiting the admissible operating pressure has to be ensured on the system side.

The pressure relief valves necessary for that purpose are to be designed considering the maximum flow and the existing pressure increase speed so that the admissible intermittent operating pressure is not exceeded.

2.5 Pressure holding function

In the variable-speed drive, the pump can temporarily also be operated below the specified minimum speed, in the pressure holding function. The holding time and the related necessary speed result from the operating viscosity and the pressure level. For the design, please contact Bosch Rexroth's Technical Sales.

In the deactivated condition (speed = 0), a leakage flow flows through the pump back into the reservoir, depending on the load pressure. If this is to be securely prevented, a check valve has to be used.

When using a check valve, please observe the information on bleeding in chapter 2.1.

3. Mechanical project planning

3.1 Installation and disassembly option

For installing and disassembling the pump on or from the drive, accessibility has to be provided for on the system side by means of suitable lifting gear. Please consider especially the own weight of frame size PGH 5 (see "Technical Data", page 5).

Screws of the property class 8.8 or 10.9 have to be provided for mounting purposes.

3.2 Mounting

On the machine side, the screws have to be accessible in a way that the required tightening torque can be applied. The tightening torque is based on the operating conditions and involved elements of the screw connection and has to be specified by the manufacturer in the power unit, machine or system project planning.

3.3 Reservoir

In the reservoir construction or the selection of suitable standard reservoirs, the following requirements are to be observed:

- Selection of the largest reservoir volume possible, depending on the continuous or average flow, in order to allow for the separation of air bubbles by means of enough dwell time of the medium in the reservoir. In this connection, the air separation capability of the fluid used is also important.
- Provision of settling zones for the fluid in the reservoir in order to allow for air separation.
- Provision of guiding plates in order to allowing for the deposit of contamination at the reservoir bottom outside the pump suction area.
- Large dimensioning of the reservoir surfaces depending on the heat output to be dissipated via the reservoir walls.

3.4 Required power unit functions

Hydraulic power units should at least be equipped with the following features:

- Reservoirs, the internal pressure of which corresponds to the ambient pressure in accordance with the design, have to be equipped with ventilation filters for pressure compensation purposes.
- The fluid should be filled by means of filling connections only excluding filling with unfiltered fluid.
- Pollution or humidity must be prevented from getting into the system. When using the pump in a highly polluted environment, the reservoir is to be pre-tensioned by means of air pressure for this. If cleansing of the external reservoir side is intended or to be expected during the period of use, reservoir fittings for tubes, lines, or hoses have to be selected, which ensure safe seal against external pressurization with water jet.

3.5 Place of installation and ambient conditions

With places of installation from a geodetic height of more than 1000 m, the pump is to be arranged in or below the reservoir or the reservoir is to be pre-tensioned by means of compressed air in order to comply with the admissible minimum inlet pressure. The suction line is to be selected short and with a large cross-section, bends should not be used.

When installing the pump more than 10 m below the reservoir, the reduction of the inlet pressure to the maximum admissible value has to be ensured by means of additional measures.

When operating the pump in salt-containing or corrosive environments or when pressurization with strongly abrasive substances is possible, it has to be ensured on the system side that the shaft seal ring and the sealing area of the shaft do not make direct contact with the environment.

Project planning information

3.6 Installation positions

IM B3

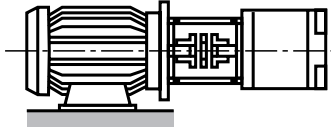

IM B5

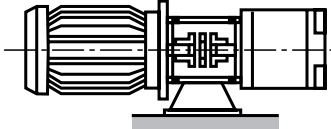

IM V1

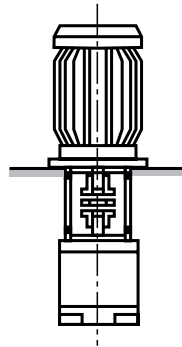

IM V2

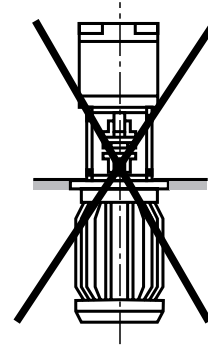

⚠ Attention!

Installation position motor at bottom and pump at top (e.g. IM V2) is not admissible!

4. Pump combinations

- It has to be ensured with pump combinations that the operating data admissible for the relevant pump type is complied with in every stage.
- The combined pumps must all have the same direction of rotation.
- The pump with the largest torque, variable displacement pumps or pumps with intermittent load are to be provided as first stage in the pump combination.
- The maximum through-drive torque must be checked by the project planner for every application. This also applies to already existing (encoded) pump combinations.

- A pump stage drive torque is calculated as follows:

$$T = \frac{\Delta p \cdot V \cdot 0.0159}{\eta_{\text{hydr.-mech.}}}$$

- T : Torque in Nm
- Δp : Operating pressure in bar
- V : Displacement in cm³
- η : Hydraulic-mechanical efficiency

Maximum admissible torques in Nm:

Type	Drive torque		Output torque
	Cylindrical shaft ..E	Splined shaft ..R	
PGH4	450	450	280
PGH5	1100	1400	700

- The total of the torques in a pump combination must not exceed the max. drive torque.
- Joint aspiration is not possible.
- For reasons of stability, we recommend the ISO 4-hole mounting flange according to VDMA "E4" for combinations of three and more pumps
- Before operating pump combinations with different mediums, please consult Bosch Rexroth.
- Central and back pumps must have the shaft design "R" (splined).

Project planning information

5. Maintenance schedule and operational safety

For safe operation and a long service life of the pump, a maintenance schedule has to be developed for the power unit, the machine, or the system. The maintenance schedule has to ensure that the intended or admissible operating conditions of the pump are complied with during the period of use.

In particular, compliance with the following operating parameters has to be ensured:

- The required oil cleanliness
- The operating temperature range
- The level of the operating medium

Furthermore, the pump and the system have to be checked for modifications of the following parameters on a regular basis:

- Vibrations
- Noise
- Temperature difference pump – fluid in the reservoir
- Foam formation in the reservoir
- Leak-proofness

Modifications of these parameters indicate wear of components (e.g. drive motor, coupling, pump, etc.). The cause has to be determined and remedied immediately.

In order to achieve high operational safety of the pump in the machine or system, we recommend checking the parameters mentioned above continuously and automatically and shutting the system down automatically in case of modifications exceeding the usual fluctuations in the intended operating range.

Plastic components of drive couplings should be replaced regularly, however, after 5 years at the latest. The corresponding information of the manufacturer is to be observed.

For preventive maintenance of the pump, we recommend having the seals replaced after a maximum operating period of 5 years by an authorized Bosch Rexroth service company.

6. Accessories

6.1 SAE connection flanges

We recommend selecting the SAE flanges for suction and pressure port according to AB 22-15 (with welded connection) or AB 22-13 (with threaded connection).

6.2 Pump safety block

For limiting the operating pressure and for the pump circulation at zero pressure, we recommend our pump safety blocks type DBA... according to RE 25890.

Automatic bleeding upon commissioning is, however, not possible via DBA blocks. In this connection, we recommend a separate manual or automatic bleeding, e.g. via the pump's measurement port (see page 19)!

6.3 Other accessories

To install the Rexroth PGH.-3X internal gear pump on electric motors, we recommend selecting the pump mounting brackets according to AB 41-20 and torsionally flexible couplings according to AB 33-22.

Commissioning notes

Preparation

- Check whether the system has been installed carefully and cleanly.
- Only fill in hydraulic fluid in through a filter with the required minimum retention rate.
- Via suction or pressure pipe, fill the pump completely with the hydraulic fluid.
- Check the direction of rotation for compliance with the direction of rotation according to the pump type.

Bleeding

- Open the bleed port at the system or switch to circulation at zero pressure, according to the system operating instructions. During bleeding, discharge of enclosed air at zero pressure must be guaranteed.
- For bleeding the pump, switch the pump on and immediately off again (jog mode). This process is to be repeated until complete bleeding of the pump is ensured.
- Close the manually opened bleed ports again.

Commissioning

- If complete bleeding of the pump has been ensured, switch on the motor. Let the pump run at zero pressure until the system is completely bled. For the bleeding of the system, the system operating instructions are to be observed.
- Commission the system according to the system operating instructions and load the pump.
- After some operating time, check the hydraulic fluid in the reservoir for bubble or foam formation at the surface.

Operation

- Pay attention to changes in the noise characteristic during operation. Due to heating of the operating medium, minor noise increases are normal. Considerable increase in the noise or random short-term changes in the noise may be an indication of the aspiration of air. If the suction tubes are too short or the operating medium filling levels are too low, air can also be sucked in via a vortex.
- Changes in operating speeds, temperatures, noise increase or power consumption are an indication of wear or damage at the system or the pump.

Re-commissioning

- Check the pump and the system for leakage. Leaks are an indication of leakage below the hydraulic fluid level. An increased hydraulic fluid level in the reservoir is an indication of leakage above the hydraulic fluid level.
- If the pump is arranged above the hydraulic fluid level, the pump may run empty due to leakage, e.g. a worn shaft seal. In this case, the system must be bled once again during re-commissioning. Provide for repair.
- After repair and maintenance works, you must bleed the system once again.
- If the system is intact, switch on the motor.

General

- The pumps supplied by us have been tested for function and performance. Modifications of any type at the pump are not permitted since this would result in the invalidation of warranty claims!
- Repairs may only be carried out by the manufacturer or their authorized dealers and agencies. Repairs carried out by the customer are not covered by a warranty.

Important notes

- The pump may only be installed, maintained and repaired by authorized, trained and instructed personnel!
- The pump may only be operated within the admissible data (see page 4 and 5)!
- The pump may only be operated if it is in an unobjectionable condition!
- When carrying out any work on the pump, depressurize the system!
- Unauthorized conversions or modifications, which affect safety and function are not permitted!
- Protective devices (e.g. coupling protection) are to be attached and/or existing protective devices must not be removed!
- Make sure that all mounting screws are always properly tightened! (Observe the prescribed tightening torque!)
- The generally valid safety and accident prevention regulations must imperatively be complied with!

Bosch Rexroth AG
Hydraulics
Zum Eisengießer 1
97816 Lohr am Main, Germany
Phone +49 (0) 93 52 / 18-0
Fax +49 (0) 93 52 / 18-23 58
documentation@boschrexroth.de
www.boschrexroth.de

© This document, as well as the data, specifications and other information set forth in it, are the exclusive property of Bosch Rexroth AG. It may not be reproduced or given to third parties without its consent. The data specified above only serve to describe the product. No statements concerning a certain condition or suitability for a certain application can be derived from our information. The information given does not release the user from the obligation of own judgment and verification. It must be remembered that our products are subject to a natural process of wear and aging.