



I Application

The KS/KSF pumps are sanitary progressive cavity pumps. Due to the design, they are self-priming and reversible pumps that can suck from a maximum height of 7 meters. These types of pumps transfer products of low and high viscosity as well as products containing particles.

They are widely used to pump edible oils, wine, concentrates and beverages in general as well as viscous food products such as jam and marmalade, pasta, pâté, etc. In the cosmetics industry, these pumps are used in applications involving various cosmetic products such as soaps, gels and creams.

I Operating principle

Friction between the rotor and the stator creates a vacuum in the inlet area promoting the entry of the product into the pump.

The rotor accompanies the product along the cavities created between the rotor and the stator up to the outlet.

I Design and features

Versions: bare shaft construction with bearing support (KS) or close-coupled construction with direct coupling to the drive (KSF).

Single internal mechanical seal: EN 12756 L1K.

Standard connections: DIN 11851 .

Open transmission (hygienic design).

Excentric outlet.

Painted white.

I Materials

Parts in contact with the product

AISI 316L

Other stainless steel parts

AISI 304

Lantern and bearing support

GG-25

Stator

Black NBR (according to FDA 177.2600)

Gaskets

NBR (according to FDA 177.2600)

Mechanical seal

Cer/C/NBR

Internal surface finish

Ra ≤ 0,8µm

External surface finish

bright polish

I Options

Connections: flanges, SMS, clamp, etc.

Double pressurized mechanical seal.

Mechanical seals SiC/C and SiC/SiC

Gland packing.

Stators: white EPDM (according to FDA 177.2600) and white NBR.

Gaskets: EPDM (according to FDA 177.2600).

Heavy-duty transmission.

Fixed transmission.

Stainless steel trolley.

Electrical panel.

Bypass pressure relief valve.

Cleaning port (CIP).



I Technical specifications

Maximum flow	45 m ³ /h	198 US GPM
Maximum working pressure:		
- single stage	6 bar	87 PSI
- double stage	12 bar	174 PSI
Maximum working temperature	85 °C (as per the certified quality)	185 °F
Maximum speed	1450 rpm	
Maximum viscosity	1.000.000 mPa.s.	

I General dimensions Kiber KS

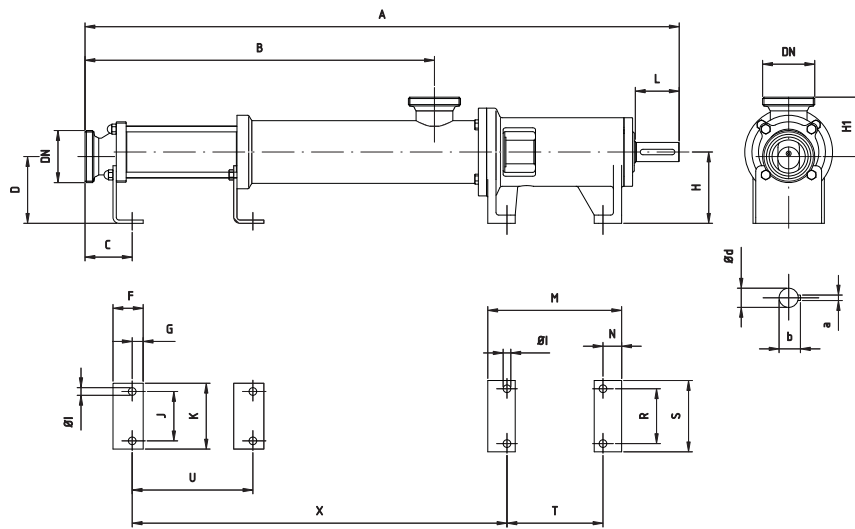

Type	DN	d	L	a	b	A	B	C	D	F	G	H	H1	I	J	K	M	N	R	S	T	U	X	
KS-20	40	1½"	20	50	6	22,5	634	324	57	87	35	12	90	83	11	45	70	179	27	70	100	125	-	356
2KS-20	734						424	-															456	
KS-25	50	2"	25	60	8	27,9	796	439	62	107	40	15	110	93	11	60	90	204	32	90	120	140	-	481
2KS-25	888						531	-															573	
KS-30	50	2"	25	60	8	27,9	796	439	62	104	40	15	110	96	11	60	90	204	32	90	120	140	-	481
2KS-30	946						589	-															631	
KS-40	65	2½"	35	80	10	38,3	1083	637	86	122	55	20	130	108	14	90	120	244	34	100	130	175	-	683
2KS-40	1273						827	410															873	
KS-50	80	3"	35	80	10	38,3	1159	713	105	117	55	20	130	133	14	90	120	244	34	100	130	175	-	740
2KS-50	1413						967	531															994	
KS-60	100	4"	48	110	14	51,5	1403	860	100	146	60	20	160	149	18	130	170	271	38	150	190	195	-	932
2KS-60	1703						1160	630															1232	
KS-80	100	4"	48	110	14	51,5	1533	990	120	132	60	20	160	163	18	150	190	271	38	150	190	195	-	1042
2KS-80	1933						1390	840															1442	

Dimensions with DIN 11851 connections



The information is for guidance only. We reserve the right to modify any material or feature without notice in advance. Photos are not binding. For further information, please, consult our web site. www.inoxpa.com



FT/KS KSF-1EN-1013

I General dimensions Kiber KSF

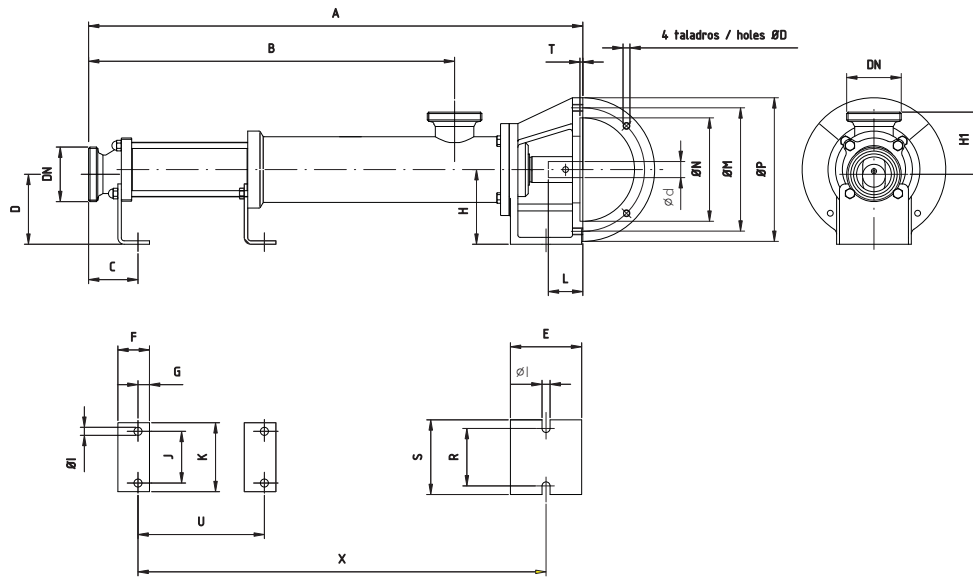

Type	DN	A	B	C	D	E	F	G	H	H1	I	J	K	R	S	U	X
KSF-20	40	489	324	57	87	101	35	12	90	83	11	45	70	70	100	-	381
2KSF-20	1½"	589	424													-	481
KSF-25	50	623	439	62	107	110	40	15	110	93	11	60	90	90	120	-	504
2KSF-25	2"	715	531													-	596
KSF-30	50	623	439	62	104	110	40	15	110	96	11	60	90	90	120	-	504
2KSF-30	2"	773	589													-	654
KSF-40	65	860	637	86	122	124	55	20	130	108	14	90	120	100	130	-	710
2KSF-40	2½"	1050	827													410	900
KSF-50	80	936	713	105	117	124	55	20	130	133	14	90	120	100	130	-	767
2KSF-50	3"	1190	967													534	1021
KSF-60	100	1115	860	100	146	121	60	20	160	149	18	130	170	150	190	-	953
KSF-80	100	1245	990	120	132	121	60	20	160	163	18	150	190	150	190	-	1063

Dimensions with DIN 11851 connections

Type	Drive coupling dimensions								
	d		L		D	M	N	P	T
	Min	Max	Min	Max					
KSF-20	19	24	42	52	M8	130	110	160	5
KSF-25	24	28	52	62	M10	165	130	200	5
KSF-30	24	28	52	62	M10	165	130	200	5
KSF-40	24	30	52	72	M12	215	180	250	5
KSF-50	24	30	52	72	M12	215	180	250	5
KSF-60	35	42	72	112	M12	265	230	300	5
KSF-80	35	42	72	112	M12	265	230	300	5



The information is for guidance only. We reserve the right to modify any material or feature without notice in advance. Photos are not binding. For further information, please, consult our web site. www.inoxpa.com



FT/KS KSF-1EN-1013



I Application

The KSF pumps are sanitary progressive cavity pumps. They are self-priming due to their design and can suction from a maximum height of 7 meters. This type of pumps can transfer products of both low and high viscosity, as well as products containing particles. It is widely used in the wine industry to transfer liquids, wines, lees, and also in filtration and bottling processes.

I Operating principle

Friction between the rotor and the stator creates vacuum in the inlet area thereby helping the entry of the product into the pump.

The turning motion of the rotor makes the cavities between the rotor and the stator move forward and transport the product to the outlet.

I Design and features

Close-coupled construction.

Pump with stainless steel trolley.

EC electric box with inverter and 10m cable with plug.

Reversible and self-priming.

Frequency inverter in the control panel.

Geared motor 3 ph 230/400 V. Y, 400 V, 50Hz, IP-55, IE2.

DIN 11851 connections..

Pump housing with drain port.

Ra \leq 8 μ m surface finish.

White painted.

EC control panel
with frequency inverter



I Materials

Parts in contact with the product

Lantern

Stator

Gaskets

Mechanical seal

AISI 316L (1.4404)

GG 22

NBR black according to FDA

NBR according to FDA

Cer/C/NBR

Pressure bypass
Liquid sensor



I Options

- Drainage with ball valve.
- Liquid sensor with timer.
- Bypass pressure relief valve.
- Mechanical seal SiC/C and SiC/SiC.
- Connections SMS, Clamp, Macon, Garolla, etc.
- Remote control.
- Mechanical speed variator(Control range).
- St.St. electric panel.

I Technical specifications

Max.flow	45 m ³ /h	198 US GPM
Max.working pressure	6 bar	87 PSI
Max.working temperature	85°C	185°F

I General dimensions

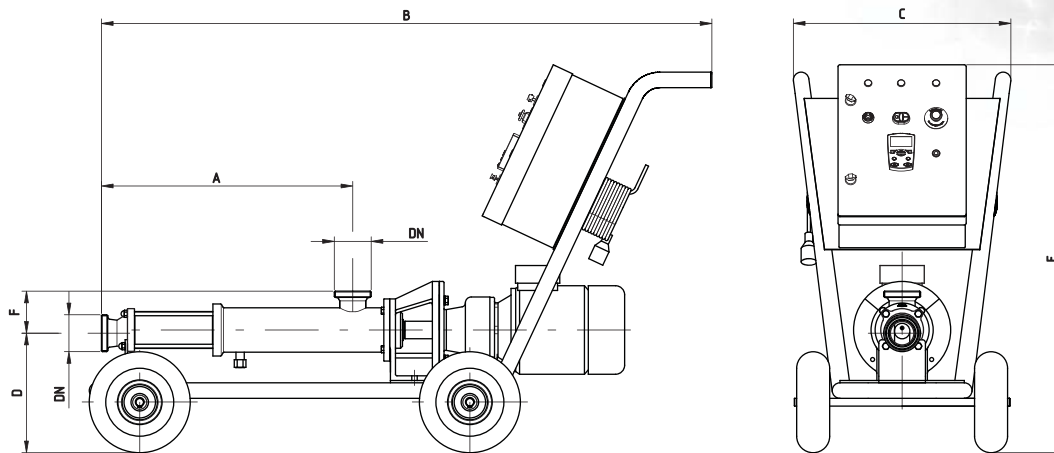

Pump	DN	Flow ¹ m ³ /h	Pressure ² bar	Speed rpm	Power kw	A	B	C	D	E	F	Weight kg	Code
KSF-20*	40 1 1/2"	0,3 – 1,7	6 max.	250 - 1000	0,75	325	1040	560	216	905	83	62	D3601-0131007CVN
KSF-25	50 2"	0,9 – 4			2,2	439	1385		293		93	79	D3602-0131022CVN
KSF-30	50 2"	1,4 – 6			2,2				290		96	80	D3603-0131022CVN
KSF-40	65 2 1/2"	2 – 9		160 – 650	3	637	1645	308	108	130	D3604-0134030CVN		
KSF-50	80 3"	4 – 15		150 – 550	4	712	1725	304	1032	145	D3605-0135040CVN		
KSF-60*	100 4"	5 – 20		100 – 400	5,5	860	1870	590	331	1100	149	262	D3606-0138055CVN
KSF-80*	100 4"	10 - 45	4 max.	100 - 400	7,5	990	2000		317		163	285	D3608-0138075CVN

(1) Nominal capacity for liquids at the maximum pressure of 2 bars
 (2) Maximum pressure with the indicated power
 (*)Trolley with three wheels





EC control panel with inverter



Level sensor



I Application

The compact and robust design of the Kiber NTE pump makes it ideal for transferring whole or destemmed grapes. And due to its design it can be installed right under the destemmer. It also can be used for the process of devatting.

I Operating principle

Friction between the rotor and the stator creates vacuum in the inlet area thereby helping the entry of the product into the pump.

The turning motion of the rotor makes the cavities between the rotor and the stator move forward and transport the product to the outlet.

I Design and features

- Highly versatile.
- Easy to clean.
- Hopper with drain.
- Robust construction.
- Motor: 3 ph 230/400 V (3 kW), 400/690 V (>3 kW), 50 Hz, IP-55.
- Helical-bevel gear units.
- Pump mounted on trolley.
- EC electric panel with ON/OFF switch, inverter and emergency stop push button.
- Standard connection: spherical coupling.
- Rotary wheels with brakes.
- Red painted RAI3003.

I Materials

Parts in contact with the media	AISI 304
Lantern	Carbon steel
Stator	NBR (specific composition for this application)
Packing gland	PTFE
Surface finish	blasted

I Options

- Liquid detector: Max / Min.
- Remote control.
- Connections: Garolla, Clamp, Flanges, DIN, etc.
- Electromagnetic brakes in motor.
- Frequency converter (Control Range).
- St.St. control panel.



I Technical specifications

Max. flow 90 m³/h 396 US GPM
 Max. working pressure 6 bar 87 PSI
 Max. working temperature 85 °C 185 °F



Type	Flow ¹ [Tn/h]	Speed [rpm]	Power [kW]	Weight [kg]
NTE-60	8/11	210	3	190
NTE-80	20/25		5.5	295
NTE-90	28/36		7.5	320
NTE-100	40/50	170	15	345
NTE-120	55/70			570

(1) Nominal flow for destemmed grapes at 2 - 4 bar / 29 - 58 PSI

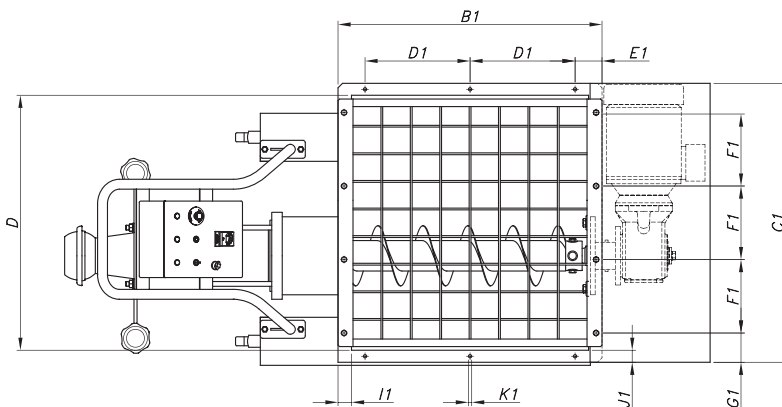
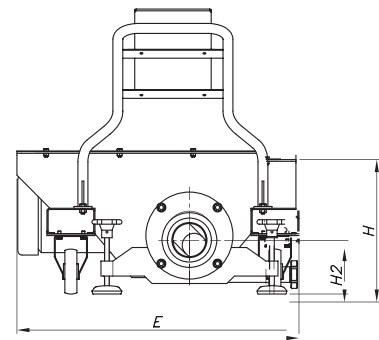
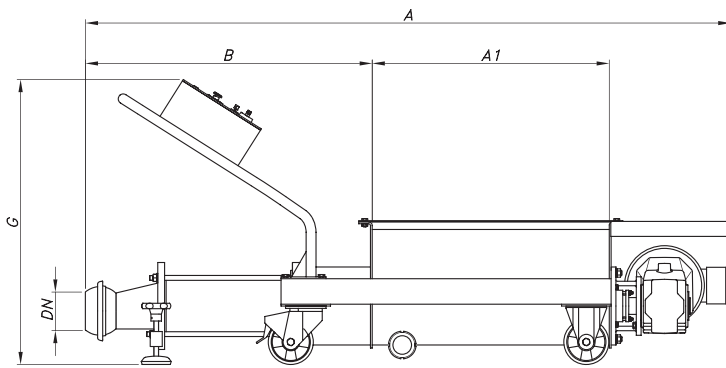

Type	DN	A	A1	B	D	E	G	H	H2	Code
NTE-60	100	171	700	740	750	835	850	405	148	D4005-2521503013
NTE-80	120	2150	790	955	850	950	950	475	180	D4008-2521005510
NTE-90		2210		1015					170	D4009-2521507510
NTE-100	150	2255	850	1060	1000	1100	950	490	165	D4010-2521507510
NTE-120		2490		1185					163	D4012-2516515012

Type	Hopper dimensions								
	B1	C1	D1	E1	F1	G1	I1	J1	K1
NTE-60	790	830	300	95	300	115	45	40	11
NTE-80	880	930	350	90	245	97.5			
NTE-90				120	275	127,5			
NTE-100				120	275	127,5			
NTE-120	940	1080							



The information contained in this brochure is for guidance only. We reserve the right to modify any material or feature without notice in advance. For further information, please, consult our web site. www.inoxpa.com



FiNTE.s.EN_0612



I Application

The NTEA pump has a very compact and robust design and it is intended for pomace transfer. This pump is supplied with a "bridge breaker" to provide a correct entry of the product to the feeder screw.

I Operating principle

Friction between the rotor and the stator creates a vacuum in the inlet area thereby helping the entry of the product into the pump.

The turning motion of the rotor makes the cavities between the rotor and the stator move forward and transport the product to the outlet.

The feeder consists of a rotating blade actuated by a gear motor, it transports the product to the feeder screw avoiding the formation of a "bridge" that impedes the pass of the product to be pumped.

I Design and features

- Highly versatile.
- Easy to clean.
- Hopper with drain.
- Robust construction.
- Motor 3 ph 400/690 V, 50 Hz, IP-55.
- Helical-bevel gear units.
- Pump mounted on trolley.
- CE electric panel with ON/OFF switch, inverter and emergency stop push button.
- Standard connection: spherical coupling.
- Rotary wheels with brakes.
- Red painted RAL3003.

Hopper with feeder



Control panel



Level sensor



I Materials

Parts in contact with the media	AISI 304
Lantern	Carbon steel
Stator	NBR (special composition for these applications)
Packing gland	PTFE
Surface finish	blasted

I Options

- Liquid detector Max / Min.
- Remote control.
- Frequency converter (Control Range).
- Connections: Garolla, Clamp, Flanges, DIN, etc.
- Electromagnetic brakes in motor.
- St.St. electric panel.



I Technical specifications

Max. flow	55 Tn/h	242 US GPM
Max. working pressure	6 bar	87 PSI
Max. working temperature	85 °C	185 °F

Type	Flow ¹ [Tn/h]	Speed [rpm]	Power [kW]	Feeder		Weight [kg]
				Speed [rpm]	Power [kW]	
NTEA-80	10 – 18	185	5,5	60	1,1	365
NTEA-100	20 – 38	169	7,5			415
NTEA-120	40 – 55	150	15			570

(1) Nominal flow for destemmed grapes at 2 - 4 bars

I General dimensions

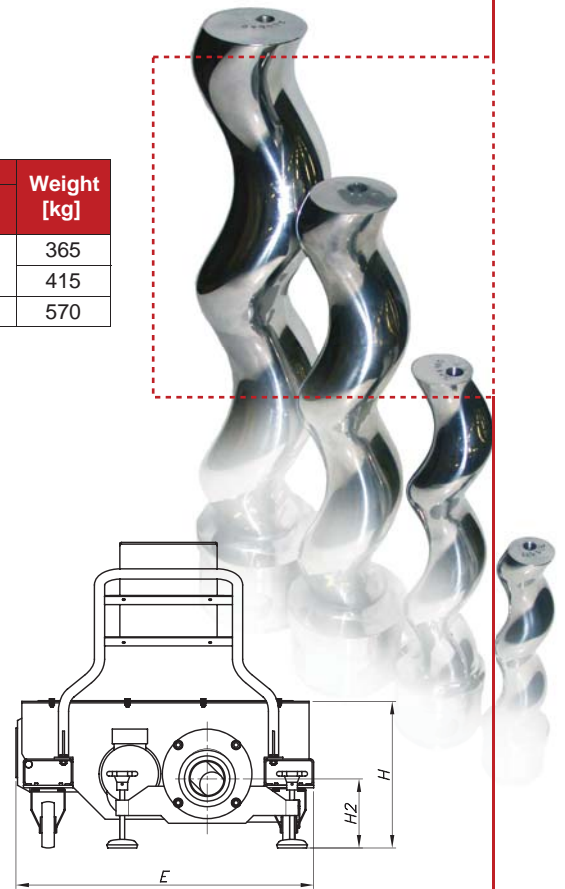
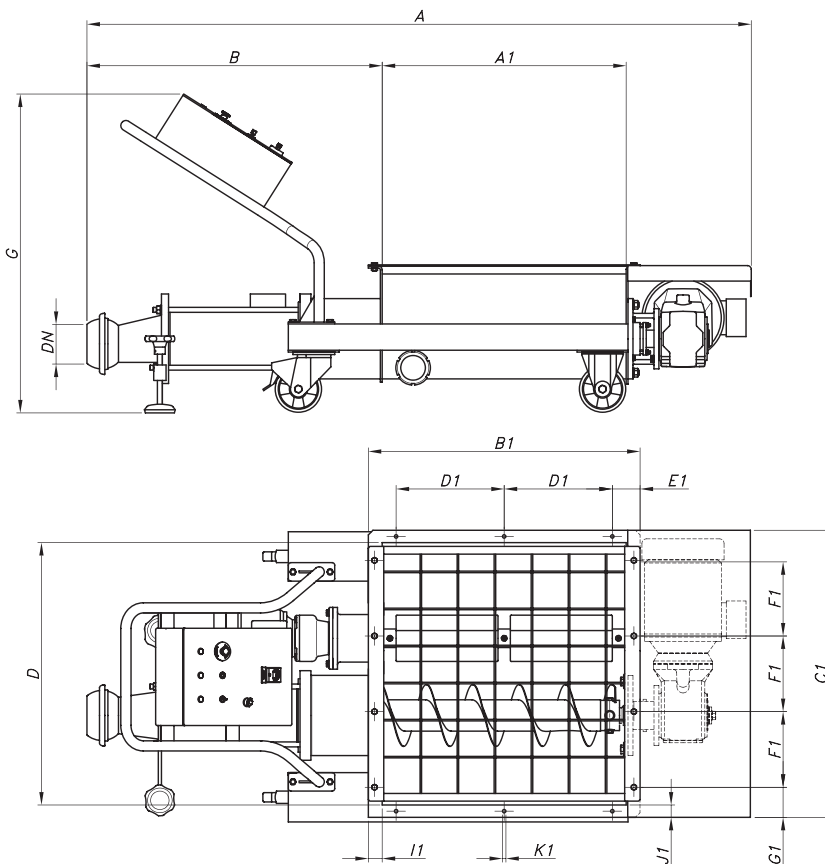

Type	DN	A	A1	B	D	E	G	H	H2	Code
NTEA-80	120	2150	790	955	850	950	1000	475	225	D4108-2519005510
NTEA-100	150	2250		1060					210	D4110-2517007511
NTEA-120	150	2930		1240					205	D4412-2516015017

Type	Hopper										
	B1	C1	D1	E1	F1	G1	I1	J1	K1		
NTEA-80	880	930	350	90	245	97,5	45	40	11		
NTEA-100		1005		120						255	120
NTEA-120											



The information contained in this brochure is for guidance only. We reserve the right to modify any material or feature without notice in advance. For further information, please, consult our web site. www.inoxpa.com



F1@NTEA.3.EN_0612



I Application

The NTE TUB pumps present compact and robust progressive cavity pumps designed for the thermovinification process in the wine-making industry.

I Operating principle

Rotation and friction between the rotor and the stator creates vacuum at the inlet area, thus, promoting the entry of the product into the pump. The connecting rod is supplied with an auger that easily delivers grape mash to the rotor and stator.

I Design and features

- Close-coupled design.
- Pump casing with an eccentric inspection port.
- Connecting rod with an auger.
- Inlet flange PN10 DIN2632.
- Eccentric discharge connection with PN10 DIN2632 flange.
- Parallel shaft gear unit.
- Motor: 3 ph 400/690 V, 50 Hz, IP-55.
- Red painted RAL 3003.

I Materials

Parts in contact with the product	AISI 304 (1.4301)
Lantern	Carbon steel
Stator	NBR (special composition for this application)
Sealing	PTFE coated packing gland
Surface finish	blasted

I Options

- Resistive probe.
- Calorimetric probe.
- Remote control.
- Discharge connections: Garolla, Macon, etc.

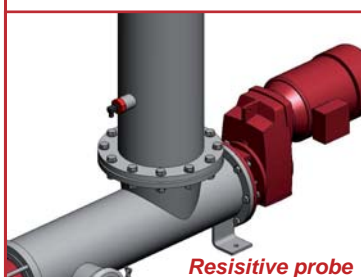
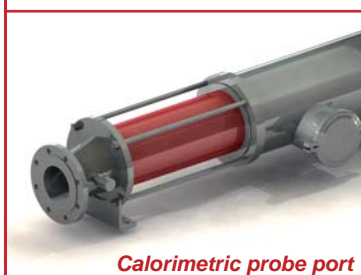
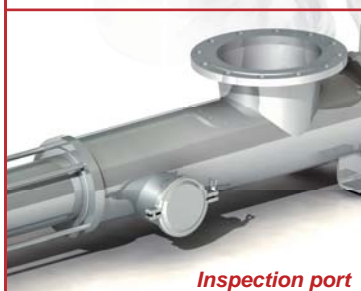

I Technical specifications

Max. flow	55 m ³ /h	242 US GPM
Max. working pressure	4 bar	58 PSI
Max. working temperature	85 °C	185 °F
Speed	175 rpm	

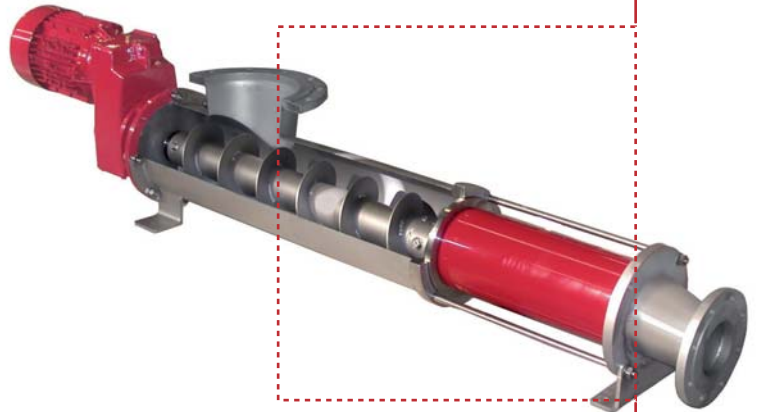

PUMP TYPE	Flow* Tn/h	Pressure bar	Speed rpm	Power kW	Weight kg
NTE 90 TUB	25 – 30	max.4	175	5,5	265
NTE 100 TUB	35 - 40		175	9,2	290
NTE 120 TUB	45 – 55		160	11	420

(1) nominal flow for grapes at 2 - 4 bar

I General dimensions

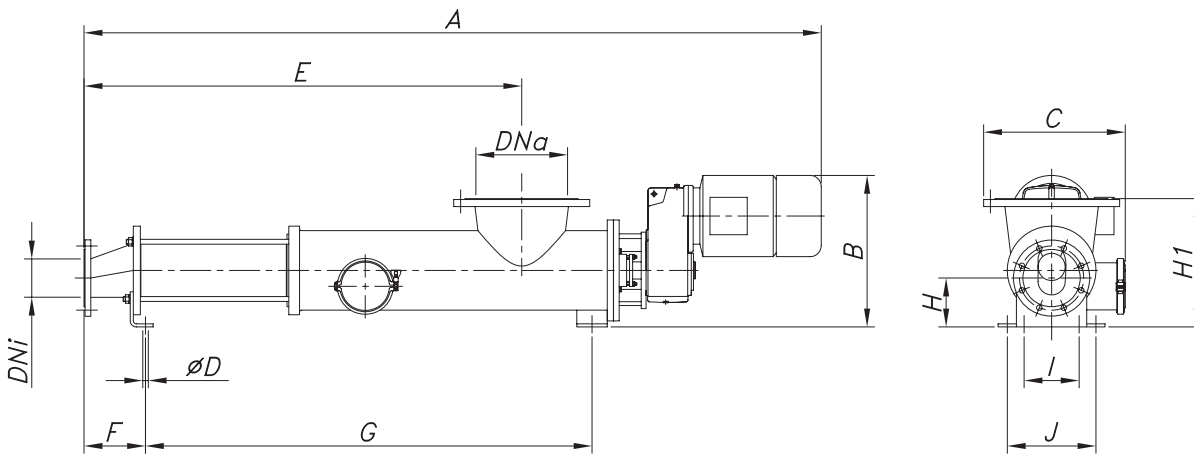

PUMP TYPE	DNa	DNi	A	B	C	D	E	F	G	H	H ₁	I	J	CODE
NTE 90 TUB	300	125	2420	500	465	18	1432	201	1461	160	420	180	290	D4509-0917505516
NTE 100 TUB	300	150	2470	500	465		1476	201	1505	155	420	180		D4510-0917509216
NTE 120 TUB	350	150	2750	590	500		1656	250	1636	172	465	200		D4512-0916011017



The information contained in this brochure is for guidance only. We reserve the right to modify any material or feature without notice in advance. For further information, please, consult our web site.

www.inoxpa.com





Hopper with auger

I Applications

The KST/KSFT pumps are sanitary progressive cavity pumps. Thanks to the hopper and auger, the pumps are suitable for pumping high viscosity products, doughs, pastes and liquids with suspended particles.

I Operating principle

The pump is always fed through the hopper and the auger accompanies the product into the pump. The rotor brings the product along the cavities created between the rotor and the stator up to the outlet.

I Design and features

Versions: bare shaft construction with bearing support (KST) and close-coupled construction with direct coupling to the drive (KSFT).

Pump casing with hopper.

EN 12756 L1K single internal mechanical seal.

DIN 11851 standard connections.

Fixed transmission.

Excentric outlet.

Painted white.

I Materials

Parts in contact with the product	AISI 316L
Other stainless steel parts	AISI 304
Lantern and bearing support	GG-25
Stator	Black NBR (according to FDA 177.2600)
Gaskets	NBR (according to FDA 177.2600)
Mechanical seal	Cer/C/NBR
Internal surface finish	Ra \leq 0,8 μ m
External surface finish	bright polish

I Options

Connections: clamp, flanges, SMS, etc.

Double pressurized mechanical seal.

Mechanical seals SiC/C and SiC/SiC.

Gland packing.

Stators in black / white EPDM (according to FDA 177.2600) and white NBR.

Gaskets in EPDM (according to FDA 177.2600).

Stainless steel trolley.

Electrical panel.

Cleaning port (CIP).



I Technical specifications

Maximum flow	45 m ³ /h	198 US GPM
Maximum working pressure:		
- single stage	6 bar	87 PSI
- double stage	12 bar	174 PSI
Maximum working temperature	85 °C (as per the certified quality) 185 °F	
Maximum speed	450 rpm	
Maximum viscosity	1.000.000 mPa.s.	

Type	Hopper dimensions							
	A1	B1	C1	D1	E1	F1	G1	I1
KST-20	300	210	70	10	10,5	63	25	10
KST-25	365	250	69	10	10	57,5	30	12
KST-30								
KST-40	420	260	130	15	15	115	40	14
KST-50	585	340	110	17,5	15,5	103	40	14
KST-60								
KST-80								

I General dimensions Kiber KST

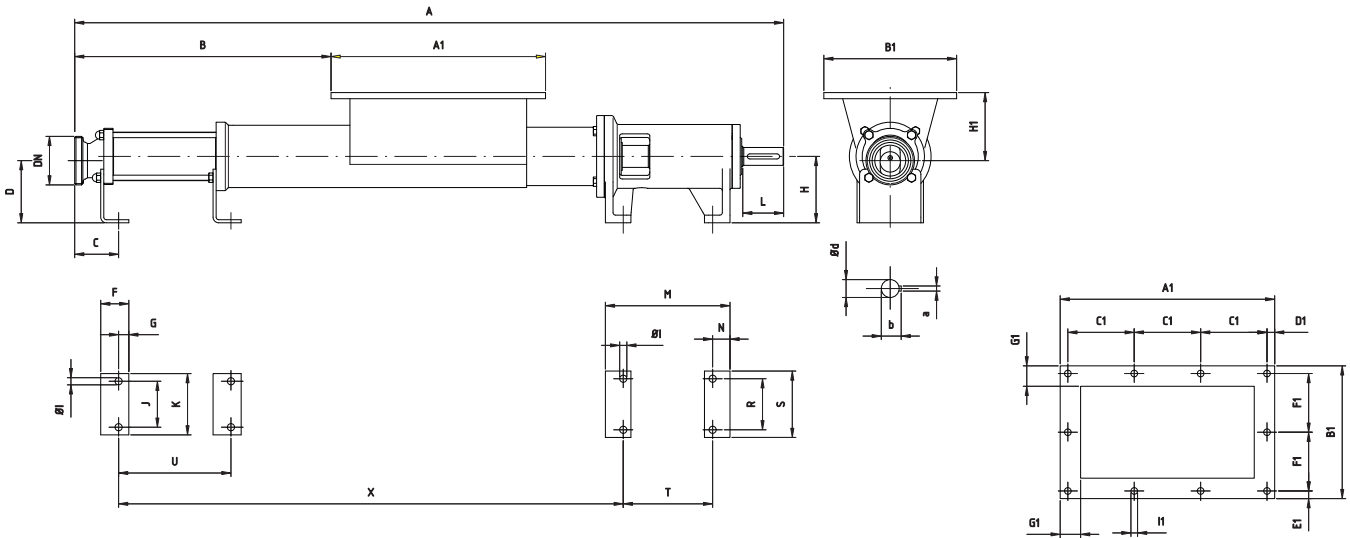

Type	DN	d	L	a	b	A	B	C	D	F	G	H	H1	I	J	K	M	N	R	S	T	U	X
KST-20	40 1½"	20	50	6	22,5	834	244	57	87	35	12	90	88	11	45	70	179	27	70	100	125	105	556
2KST-20						934	344															205	656
KST-25	50 2"	25	60	8	27,9	1031	331	62	107	40	15	110	128	11	60	90	204	32	90	120	140	166	716
2KST-25						1123	423															258	808
KST-30	50 2"	25	60	8	27,9	1031	331	62	104	40	15	110	131	11	60	90	204	32	90	120	140	166	716
2KST-30						1181	481															316	866
KST-40	65 2½"	35	80	10	38,3	1298	452	86	122	55	20	130	133	14	90	120	244	34	100	130	175	223	898
2KST-40						1488	642															413	1088
KST-50	80 3"	35	80	10	38,3	1374	528	105	117	55	20	130	138	14	90	120	244	34	100	130	175	280	956
2KST-50						1628	782															534	1209
KST-60	100 4"	48	110	14	51,5	1733	643	100	146	60	20	160	174	18	130	170	271	38	150	190	195	330	1262
2KST-60						2033	943															630	1562
KST-80	100 4"	48	110	14	51,5	1863	773	120	132	60	20	160	188	18	150	190	271	38	150	190	195	440	1372
2KST-80						2263	1173															840	1772

Dimensions with connections DIN 11851



The information is for guidance only. We reserve the right to modify any material or feature without notice in advance. Photos are not binding. For further information, please, consult our web site. www.inoxpa.com



FKST/KSFT.1.EN_1013

I General dimensions Kiber KSFT

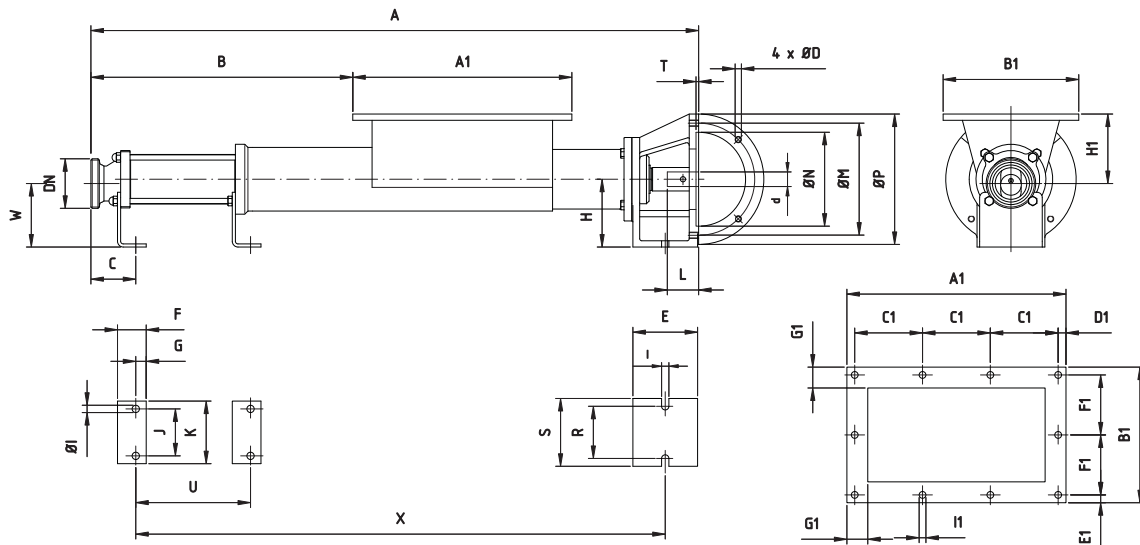

Type	DN	A	B	C	E	F	G	H	H1	I	J	K	R	S	U	X	W
KSFT-20	40	689	244	57	101	35	12	90	88	11	45	70	70	100	105	581	87
2KSFT-20	1½"	789	344												205	681	
KSFT-25	50	858	331	62	110	40	15	110	128	11	60	90	90	120	166	739	107
2KSFT-25	2"	950	423												258	831	
KSFT-30	50	858	331	62	110	40	15	110	131	11	60	90	90	120	166	739	104
2KSFT-30	2"	1008	481												316	889	
KST-40	65	1075	452	86	124	55	20	130	133	14	90	120	100	130	223	925	122
2KSFT-40	2½"	1265	642												413	1115	
KSFT-50	80	1151	528	105	124	55	20	130	138	14	90	120	100	130	280	982	117
2KSFT-50	3"	1405	782												534	1236	
KSFT-60	100	1445	643	100	121	60	20	160	174	18	130	170	150	190	330	1283	146
KSFT-80	100	1575	773	120	121	60	20	160	188	18	150	190	150	190	440	1393	132

Dimensions with connections DIN 11851

Type	Drive coupling dimensions								
	d		L		D	M	N	P	T
	Min	Max	Min	Max					
KSFT-20	19	24	42	52	M8	130	110	160	5
KSFT-25	24	28	52	62	M10	165	130	200	5
KSFT-30	24	28	52	62	M10	165	130	200	5
KSFT-40	24	30	52	72	M12	215	180	250	5
KSFT-50	24	30	52	72	M12	215	180	250	5
KSFT-60	35	42	72	112	M12	265	230	300	5
KSFT-80	35	42	72	112	M12	265	230	300	5

Type	Hopper dimensions							
	A1	B1	C1	D1	E1	F1	G1	I1
KSFT-20	300	210	70	10	10,5	63	25	10
KSFT-25	365	250	69	10	10	57,5	30	12
KSFT-30	420	260	130	15	15	115	40	14
KSFT-40	420	260	130	15	15	115	40	14
KSFT-50	420	260	130	15	15	115	40	14
KSFT-60	585	340	110	17,5	15,5	103	40	14
KSFT-80	585	340	110	17,5	15,5	103	40	14



The information is for guidance only. We reserve the right to modify any material or feature without notice in advance. Photos are not binding. For further information, please, consult our web site. www.inoxpa.com

