

WANGEN PUMPEN
Product overview

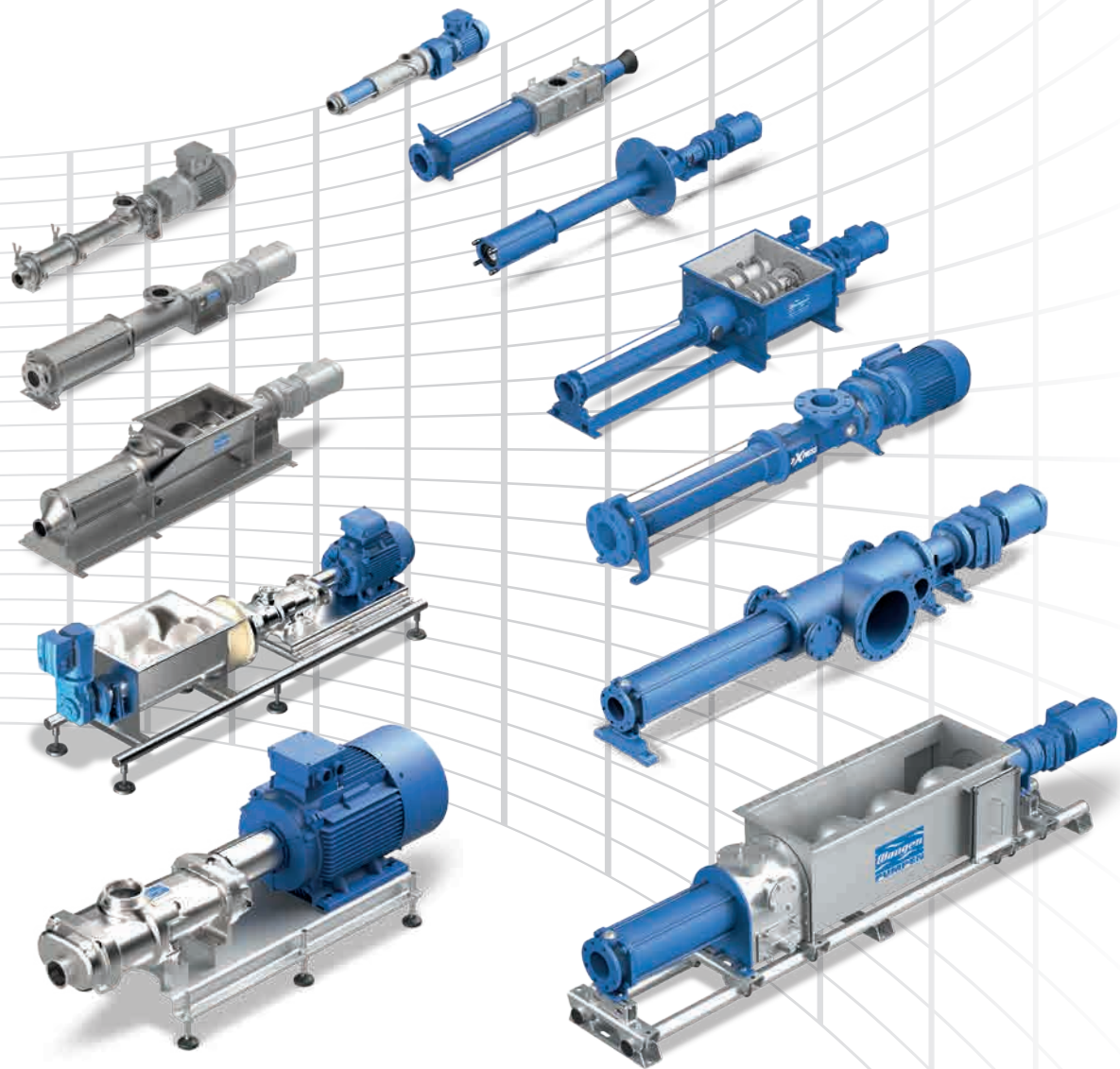

Convincing high quality and flexibility:
The complete pump range

Who we are

WANGEN PUMPEN - The Company

Conscientious, fast, strong.

WANGEN PUMPEN is a mechanical engineering company and provider of high-quality displacement pumps for industrial applications. The extensive product range includes eccentric screw pumps and screw pumps for a wide range of industries, e.g. for pharmaceutical, food and beverage production, shipbuilding, the environment, biogas / anaerobic digestion and agricultural equipment, as well as the chemical, paper and cosmetic industries.

Since it was founded in 1969, WANGEN pumps has evolved continuously from a craft operation to a medium-sized company with more than 200 employees.



Headquarters building in Wangen, Germany

The pumps from WANGEN enjoy the highest reputation thanks to our consistent focus on market and customer requirements – regionally, nationally and internationally.

WANGEN PUMPEN offers

First Class Quality

Quality by tradition and as a matter of conviction

Flame-hardened rotors, stators, pump housing, seals, high alloyed tool steel or hardened steel: pumps made by WANGEN are designed and made for highest loads and maximum lifetime.

The WANGEN PUMPEN quality management is certified to ISO 9001:2008 and ensures the commitment of the high standards over all production steps of our high production depth, including all pump generations.



Rotor at flame-hardening process

WANGEN PUMPEN is:

Reliable

Reliability can only arise where issues are reliably thought through and acted upon. Reliable, professional and motivated work is a prerequisite in order to compete as a producer of high-quality products. This starts with development and construction and continues via production, consultancy and sales to service.



Customer Oriented

Product and service quality must be congruent. That is why we compile the wishes, needs and expectations of our customers on a regular basis and systematically analyze and transpose them into products, services and interactive processes, intra-departmental and across locations throughout the entire company.



Flexible

Our world is changing at an ever faster rate, and the intervals are getting shorter. Due to the high stability of our base, we are able to respond to the ever changing set of conditions or to recognize them already in advance before they become acute. The ability to react quickly is an integral part of our success.

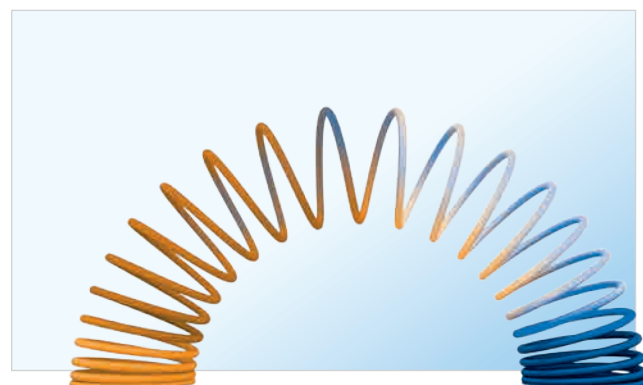

Technology of our pumps

Progressing cavity pumps

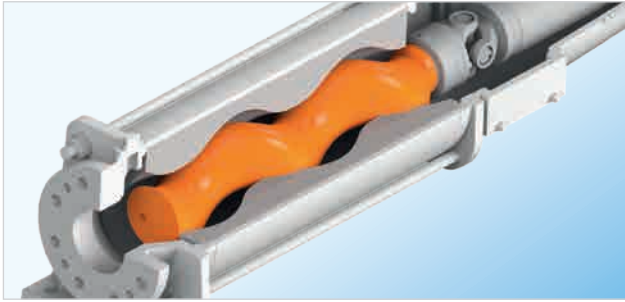

Modular, extremely robust, precise dosing, low pulsation. Large range of models and materials used for housings, rotor, stator, seals, joints ensures an optimum match to the medium being pumped. Our wide range of flanged connections and drives ensures the best possible solution for your installation and space.

Twin screw pumps

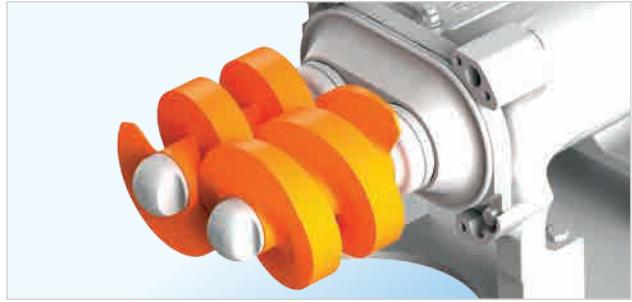

Non-contact feed screw operation, efficient, compact. Developed to reliably convey low to highly viscous, volatile or gaseous products. Its design avoids dead space and stagnation zones. Due to their high speed range, they can be used as a process pump and as a cleaning pump.

Product benefits

Maximum variability

WANGEN pumps are modular in design. A large variety of standardized components is available for each series and allows the customization of each pump to your specific needs. Regardless of your business activity, what medium has to be conveyed, and what your operational needs are: We offer you the optimal solution for your application and thereby ensure maximum efficient pumping solutions for your business.

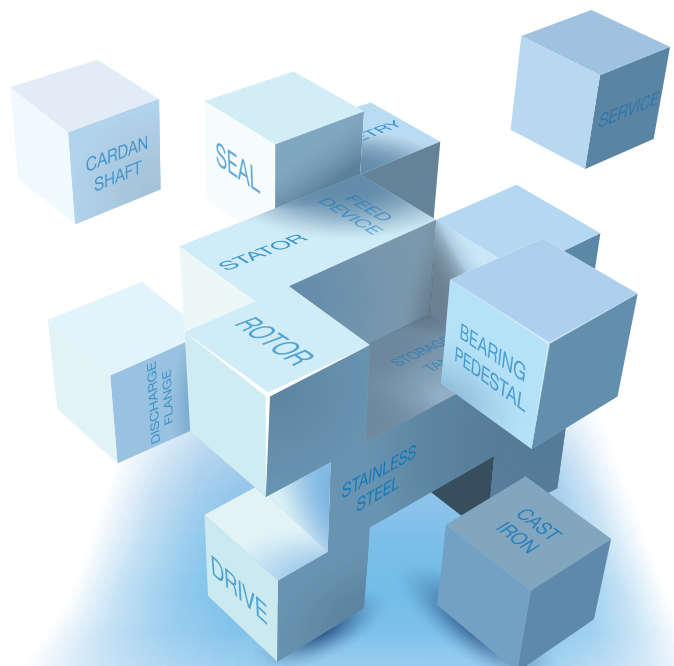

WANGEN PUMPEN

Applications of our pumps

WANGEN PUMPEN covers all application areas and industry sectors with its modular products. The table below gives you an overview of our product groups and their areas of application. If you cannot find your particular special area, you can be sure: we either already also have a solution, or we will develop one – individually and in close cooperation with you.

Product groups	Hygienic pumps		Industrial pumps					
	Twin screw pumps	Progressing cavity pumps	Self-priming pumps	Special hopper feed pumps	Standard hopper feed pumps	High performance hopper feed pumps	PTO shaft pumps	Immersion pumps
Applications	Twin VarioTwin	KL-SL KB-SL KL-TL HYLINE KL-RL / -RF	KL-S KB-S Xpress BIO-FEED Polymer	BIO-MIX	KL-R	KL-RÜ KL-RQ KL-RS KL-R Triplex	A GL-F GL-S	KL-T
	Page 6-7	Page 8-9	Page 10-12	Page 13	Page 14	Page 15	Page 16	Page 17
Sewage water treatment			•		•	•		•
Biogas / anaerobic digestion			•	•	•			•
Construction, stone, earths			•		•	•		•
Chemicals	•	•	•		•			•
Paints and surface coatings	•	•	•		•			•
Cosmetics	•	•						
Agriculture					•		•	
Food and beverage	•	•						
Pharmaceuticals	•	•						
Paper	•		•					•
Petrochemicals			•		•			•
Ship building			•					•

Twin screw pumps

WANGEN Twin

Convey with up to 25 bar liquid and paste-like food products with viscosities up to 1,000,000 mPa·s hygienically and efficiently.

Compact. Clean. Practical. The hygienic WANGEN Twin screw spindle pumps combine a unique hygienic design with versatile conveying characteristics. This special design ensures extremely low levels of contamination of the WANGEN Twin and allows an extraordinary thorough and quick cleaning (fast hand washing, excellent CIP cleaning, practically wear-free). Another big advantage: You can convey and CIP clean with just one and the same pump.

The WANGEN Twin is especially suitable for volatile and gaseous media, as well as for the promotion of low to highly viscous media and liquids. Ideal for the filling and emptying tanks.

The WANGEN Twin series is available in three model sizes and as an EHEDG- or 3A (Sanitary Standard) certified version.

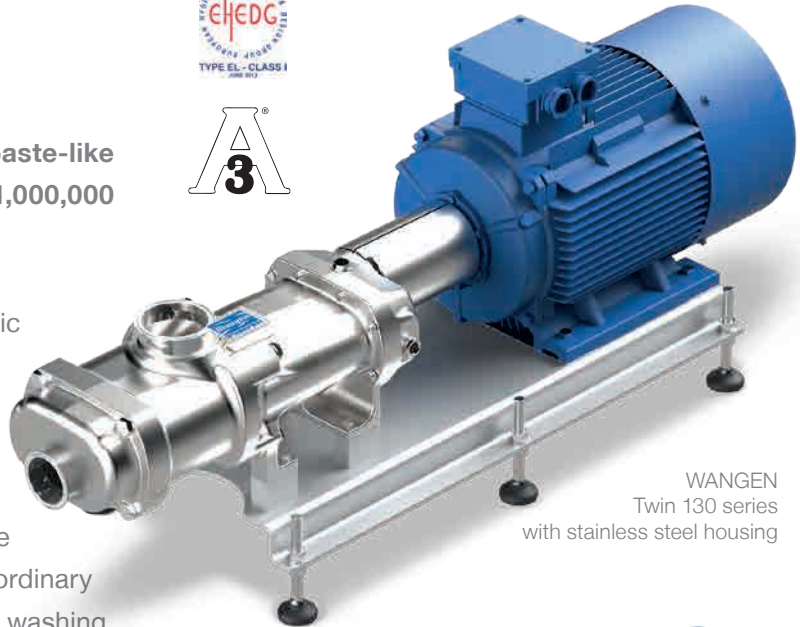

WANGEN Twin 130 series with stainless steel housing

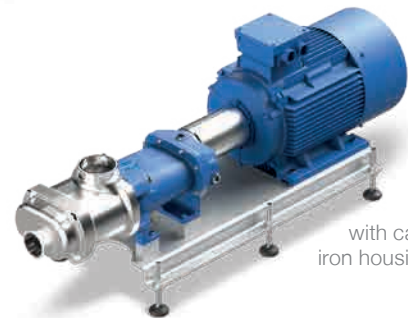

with cast iron housing

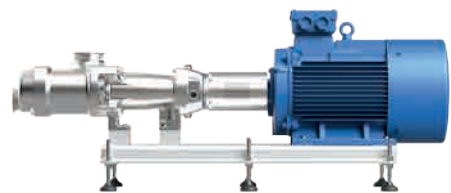

view from the side



Max. flow rate (m³/h):

0	100	200	300	400	500	600
100						

Max. differential pressure (bar):

0	10	20	30	40	50
25					

Twin screw pumps

WANGEN VarioTwin

Hygienic and gentle conveying of food with viscosities up to 3.000.000 mPa·s.

Due to forced feeding of the media via feeding screw into the pump the VarioTwin is the ideal supplying unit for the WANGEN Twin series 104 and 130 to pump highly viscous, not flowable media.

To balance the fluctuations, the 'coreless' feeder used in WANGEN pumps ensures a large buffer volume during media supply. At the front section of the feeder, excess material is returned by the axial feeder cavity to the rear section and thus balances the feed volume in the case of temporarily low material supply. This ensures a constant even filling during the feed process.

The hygienic and patented add-on module to the WANGEN Twin screw pump.

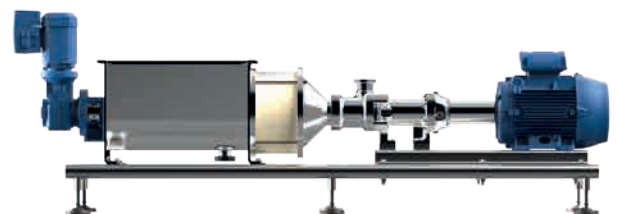
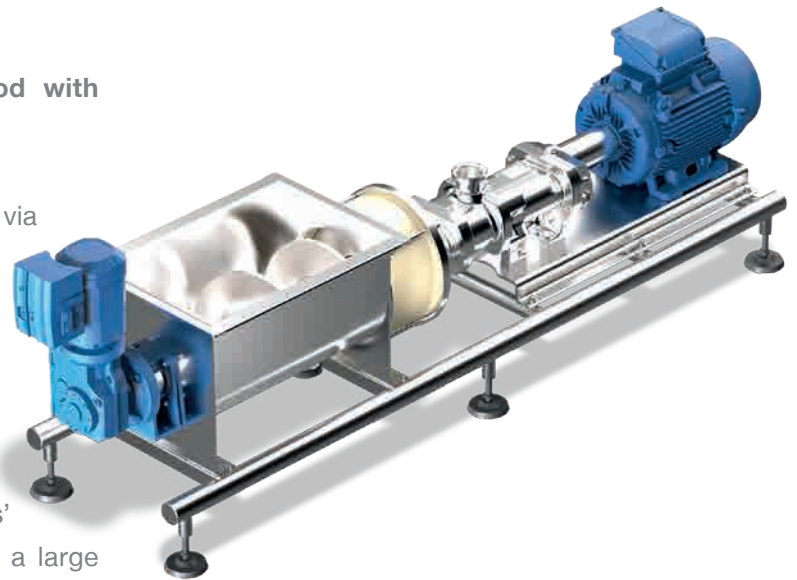

view from the side

„coreless screw“ in WANGEN VarioTwin

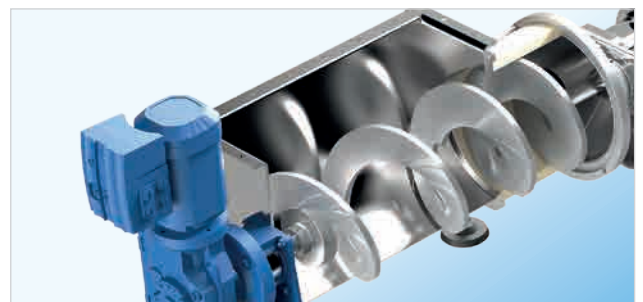

Max. flow rate (m³/h):

0	100	200	300	400	500	600
10						

Max. differential pressure (bar):

0	10	20	30	40	50
		25			

Progressing cavity pumps

Self-priming pumps KL-SL, KL-TL, HYLINE, KB-SL

For hygienic conveying processes with low to high viscous media.

The pumps of the KL-SL series convince with their ease of cleaning and low dead-space construction. The pump can optionally be operated in a heating or cooling mode. Further quality characteristics are CIP (Cleaning in Place), low pulsation, and continuous pumping independent of pressure and viscosity.

The WANGEN progressing cavity pump type KL-TL / KB-TL is suitable as an immersion pump for pumping mediums out of tanks and basins. Regardless of the medium's consistency, it is conveyed as careful as possible without impairing its structure and quality.

The WANGEN HYLINE has a maintenance-free flexible joint with similar diameters, therefore no deposits of the conveyed medium possible. Compact size, optimal for dosing. Large selection of sealing shafts.

The KB20SL, KL30SL and KL50SL series are also available in the „Hygienic“ version which is certified according to the guidelines of the European Hygienic Engineering and Design Group (EHEDG). High dosing accuracy also at low rotational speeds and the extremely high level of safety in operation. The KB-SL is available optionally with one or two tangentially inclined cleaning connections.

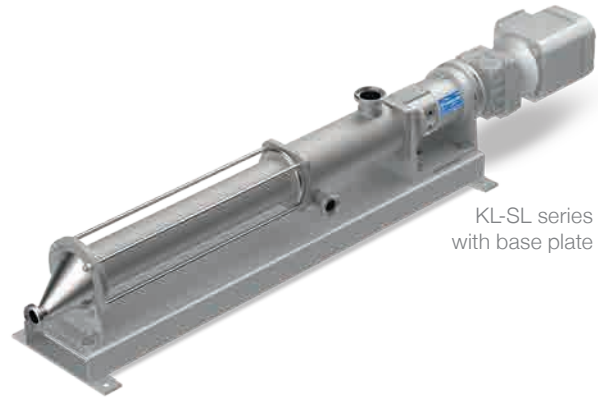

KL-SL series with base plate

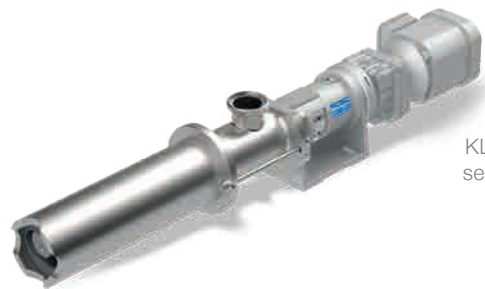

KL-TL series



HYLINE series



KB-SL series



Max. flow rate (m³/h):

0	100	200	300	400	500	600
260						

Max. differential pressure (bar):

0	10	20	30	40	50
48					

Progressing cavity pumps

Hopper feed pumps KL-RL, KL-RF

Hygienic and gentle conveying of food with up to 1.000.000 mPa·s

Hygienic progressing cavity pumps convey and dose products of the food, pharmaceutical and cosmetic industries particularly well. The range of applications includes viscous liquids and non-flowing to solid products, homogenous or containing pieces, sensitively or sensitive to shearing.

A large free ball passage and the low speeds of these pumps ensure that sensitive products are conveyed particularly gently.

Pumps of the series KL-RL allow almost pulsation-free pumping of mediums. The large hopper with screw conveyor has only a minimal dead space, despite the compact construction form, and avoids stagnation zones thanks to its special design. Can be optionally heated or cooled.

Pumps of the series KL-RF have an inspection cover, a maintenance-free mechanical seal, which is independent of the rotation direction, and the discharge nozzle has a self-emptying design. Can be optionally heated or cooled.



KL-RL series with base plate

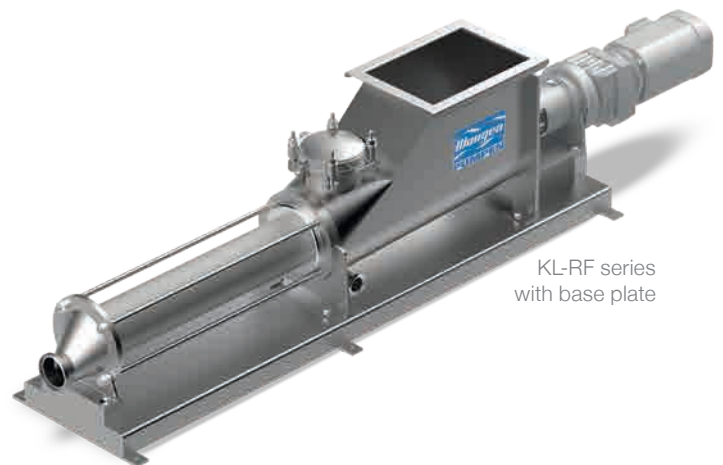

KL-RF series with base plate

Max. flow rate (m³/h):

0	100	200	300	400	500	600
65						

Max. differential pressure (bar):

0	10	20	30	40	50
					48

Progressing cavity pumps

Self-priming pumps KL-S / KB-S / Polymerpump

Secure conveying of high viscous media with up to 200.000 mPa·s.

Our self-priming pumps are used in many different industries, such as, for example, in the biogas production, wastewater management technology, ship building and mechanical engineering, the paper and chemical industries. Numerous designs and sizes and a modular design of pumps ensure that all customers receive a delivery solution, tailored to meet their individual needs.

Our basic products are progressing cavity pumps of KL-S / KB-S series. They are used to convey all self-flowing fluid materials. They pump low to high viscosity media just as well as solid-containing media.

The progressing cavity pump KB-S GG has, unlike to the KL series, a block housing and is directly connected to the drive unit. Due to this structural shape the KB-S series receives its advantageous, short shape.

The new Polymer pump is designed especially for dosing tasks. It contains a long-lasting, wear- and maintenance-free flexible joint. The housing is available in plastic or cast iron.



KL-S series; stainless steel version



KL-S series, cast iron version

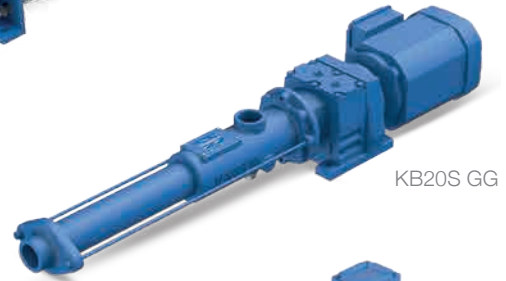

KB20S GG



Polymer pump

cardan joint in KL-S



Max. flow rate (m³/h):

0	100	200	300	400	500	600
						560

Max. differential pressure (bar):

0	10	20	30	40	50
					48

Progressing cavity pumps

Self-priming pumps WANGEN Xpress with X-LIFT

Reliable conveyance of digested sludge and low viscous media with up to 8 % DS.

The suction housing remains attached to the pipeline and the discharge pipeline remains in place. This makes it easier to work in locations that are hard to access.

Quick change of rotor and stator and reliable conveyance: therefore WANGEN PUMPEN developed the X-LIFT quick change system.

The WANGEN solution does not need additional splitting of the pump housing or additional sealing joints, additional components such as seals are unnecessary. This ensures stability and reliability of the pump remains inherent without any detriment to operational performance. Thus failure caused by leaking does not occur in the first place. Due to its block construction the pump stays very compact.

The easy removal of the discharge flange means that WANGEN customers profit exclusively from the benefits of the X-LIFT quick change system, which is currently the best solution on the market.

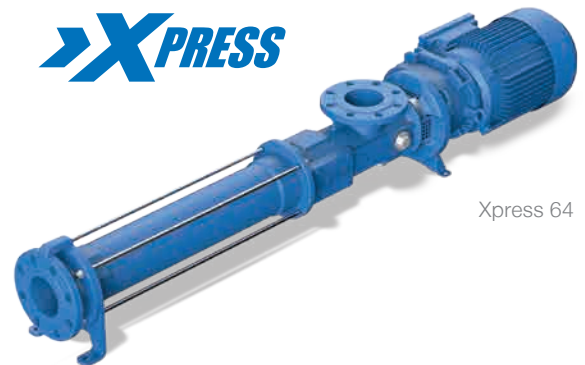
Xpress 64



cutaway model

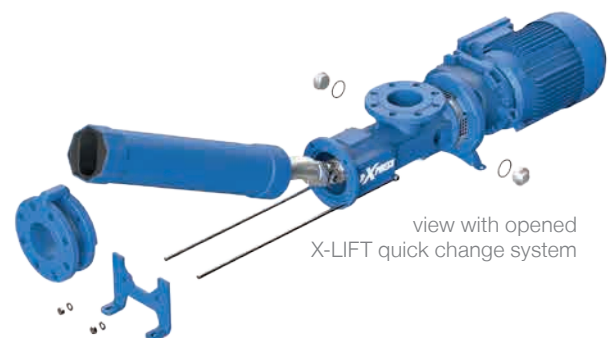

view with opened X-LIFT quick change system



Xpress 48 on base plate

Max. flow rate (m³/h):

0	100	200	300	400	500	600
56						

Max. differential pressure (bar):

0	10	20	30	40	50
6					

Progressing cavity pumps

Self-priming pumps KL-R BIO-FEED with X-LIFT

Combines liquid feeding with screw technology directly at the solids dispenser. For biogas plants and waste water treatment plants.

The BIO-FEED was developed by WANGEN PUMPEN especially for production plants that would like to combine an existing auger dosing unit for solid material with a liquid material dosage.

With a specially-developed milling screw, you can mix the solids that are to be added with the separately added liquid and convey it into the desired containers. Due to the pushing of the screw connection, the WANGEN BIO-FEED turns into a high-performance suction pump. You can use it as a central pump in your biogas plant.

With our innovative X-LIFT quick-change system, the wearing parts are easy to replace. Only a few simple steps are needed, without this requiring disassembly of the pump from the piping system.

BIO-FEED

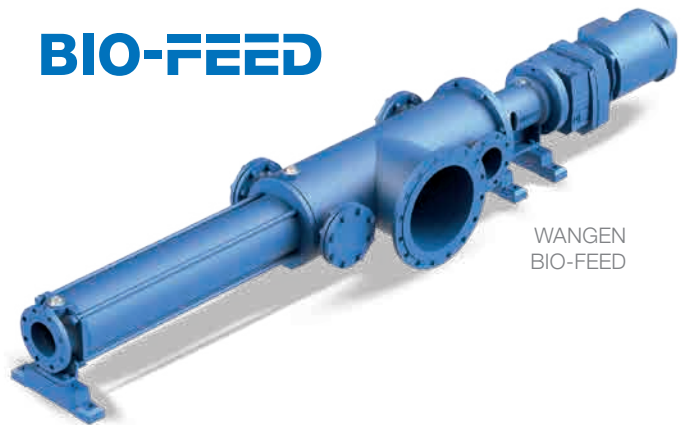

WANGEN
BIO-FEED



top view

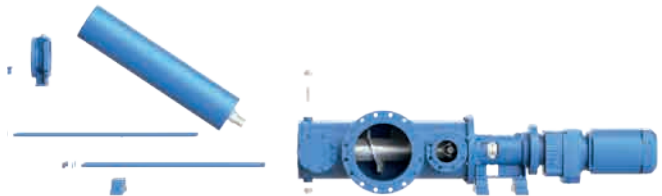

view from the side
with opened X-LIFT quick change system



WANGEN BIO-FEED in a piping system

Max. flow rate (m³/h):

0	100	200	300	400	500	600
50						

Max. differential pressure (bar):

0	10	20	30	40	50
6					

Progressing cavity pumps

Hopper feed pumps KL-R BIO-MIX

Efficiently introduce a solid fermentation substrate with a high solids content of up to 45 % into a biogas plant.

The WANGEN KL-R BIO-MIX pumps have been integrated for years into the business of energy generation and have steadily been developed and optimized ever since. They are suitable for conveying corn, grass silage, GPS, solid manure, chicken manure, waste and co-fermentation products, which are mixed with the liquid in the pump.

The consistent modular principle used allows a high degree of flexibility, low spare parts inventory and also low downtimes for carrying out repairs.

The hopper of the KL-R BIO-MIX is available in different sizes and with wear protection. The maintainability is evident, amongst other things, from the large openings used for inspections and for cleaning.

The WANGEN BIO-MIX is in standard equipped with the X-LIFT quick change system, developed by WANGEN PUMPEN.

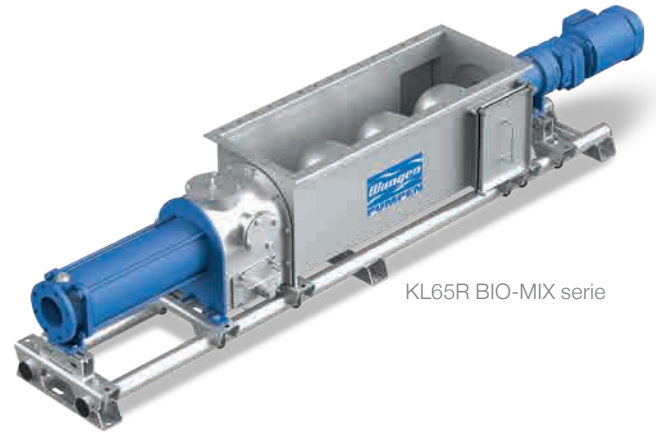

KL65R BIO-MIX serie



view from the side



top view

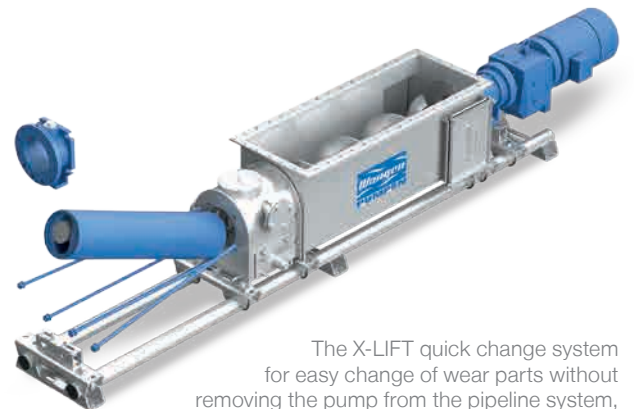

The X-LIFT quick change system for easy change of wear parts without removing the pump from the pipeline system, developed by WANGEN PUMPEN.

Max. flow rate (m³/h):

0	100	200	300	400	500	600
		150				

Max. differential pressure (bar):

0	10	20	30	40	50
					48

Progressing cavity pumps

Hopper feed pumps KL-R

Reliably convey solid slurries and pastes with a high solids content of up to 45 %.

If you want to convey solid slurries or pastes, which are no longer self-flowing, then self-priming displacement pumps, such as suction or rotary piston pumps, achieve their natural limits. The medium simply no longer reaches the conveyor unit, and the pump runs dry.

This is where our progressing cavity pumps of the KL-R series are used. They are equipped with hopper feed and worm pre-conveyor. They ensure an active and continuous supply of the product in the interior of the pump. So that even highly viscous products and dewatered sludges can still be reliably conveyed.

KL-R pumps are available in numerous model designs for promoting products ranging from waste water and waste management, agriculture and industry, according to demand.

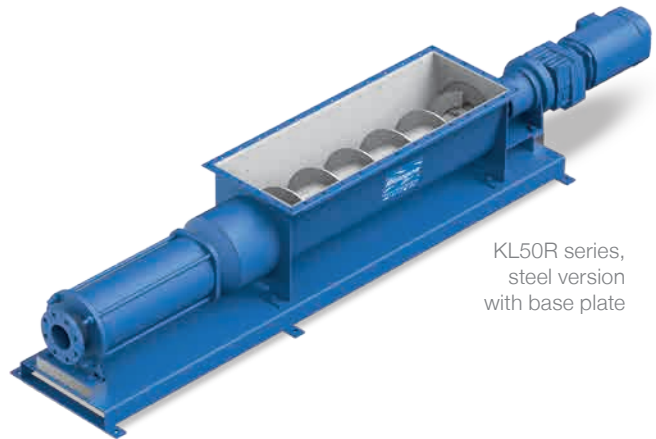

KL50R series,
steel version
with base plate



top view



KL50R series,
stainless steel version
without base plate



view from the side

Max. flow rate (m³/h):

0	100	200	300	400	500	600
225						

Max. differential pressure (bar):

0	10	20	30	40	50
48					

Progressing cavity pumps

High performance hopper feed pumps KL-RÜ, KL-RQ, KL-RS, KL-R Triplex

Reliably convey dewatered high-viscosity sludge with a high solids content of up to 45 %.

WANGEN high-performance pumps are always used when extremely dry or lumpy materials have to be conveyed.

The WANGEN pump type KL-RQ has a transverse feed device for integrated bridges refraction and a reciprocal container for the continuous feeding process. It was designed for the promotion of dewatered sludge with a high solids content (TS) ranging from 15 % to 45 %.

The KL-R Triplex has a large integrated buffer volume with up to 10 m³/h to pump a discontinuous sludge supply. Avoids bridge building at the pumped media supply.

The WANGEN pump type KL-RS is a hopper silo pump for the conveying and dosing of dewatered sewage sludge with a high solids content (TS) of 15 % to 45 %. These features make silo discharge pumps of type KL-RS an indispensable core aggregate in modern sewage treatment plants.

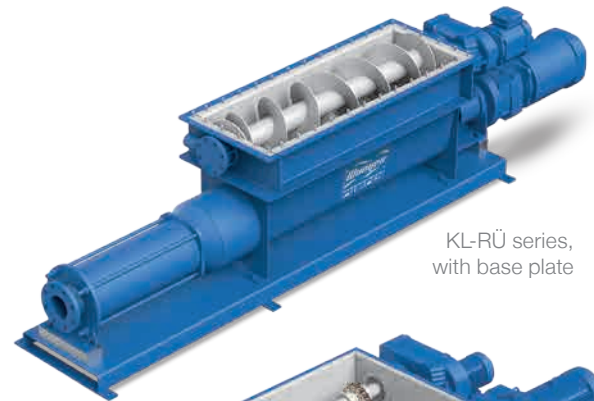

KL-RÜ series,
with base plate

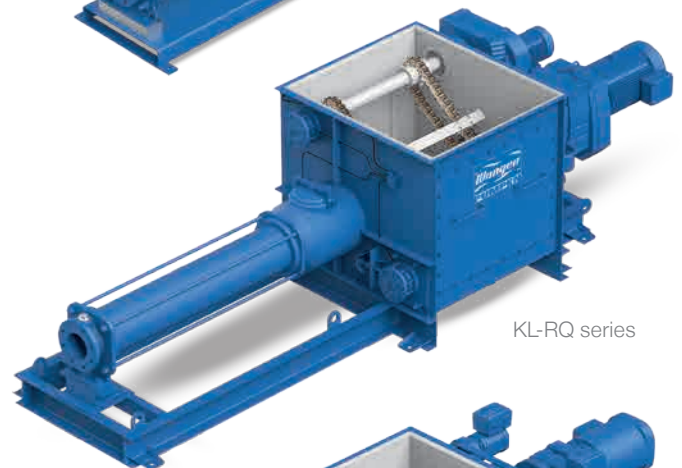

KL-RQ series

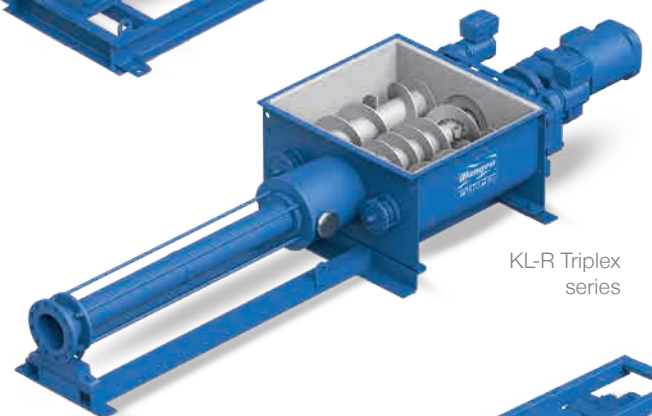

KL-R Triplex
series

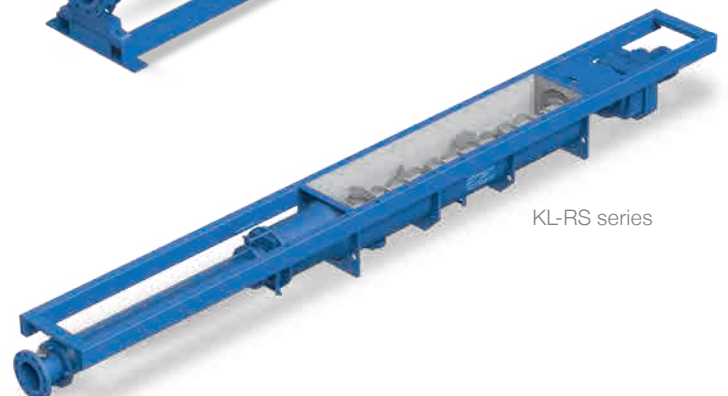

KL-RS series

Max. flow rate (m³/h):



Max. differential pressure (bar):

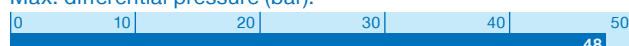

Progressing cavity pumps

PTO shaft pumps A, GL-S, GL-F

Reliable conveying of agricultural materials containing up to 15 % high solids content.

The WANGEN PTO shaft pumps have been developed specifically for use in agriculture. They are used to vacuum load and unload tanked manure supplies, distribute manure via an umbilical tubing system or to convey liquid feed.

Our PTO shaft pumps feature a free shaft end and can be powered directly from a vehicle, for example, a tractor. In this way, the farmer can perform all types of delivery processes regardless of the nature of the power supply available on the farm and in the field.

The high suction power ensures an effective emptying of the pit. Thanks to its rugged construction, these progressing cavity pumps are not sensitive to foreign bodies and ensure trouble-free operation. WANGEN PTO shaft pumps are available in three different series.



A series



GL-S series

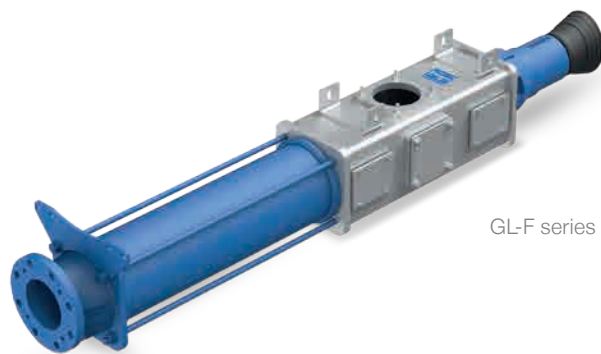

GL-F series



view from the side

Max. flow rate (m³/h):



Max. differential pressure (bar):

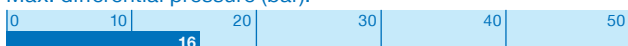

Progressing cavity pumps

Immersion pumps KL-T / KB-T

High-viscosity liquids are safely pumped out of basins and tanks. Suitable for viscosities up to 200,000 MPA-s and a dry solids content up to 16 %.

The WANGEN progressing cavity pump type KL-T is ideal as an immersion pump to convey media from tanks and pools. The pumped media - whether liquid, abrasive, lumpy, sticky or even highly viscous – are forwarded so as to be gentle on the product and without compromising the structure and quality.

Joints which are consistent in diameter ensure a constant flow rate. The WANGEN KL-T series is characterized by lack of sensitivity to foreign bodies, and only needs a small amount of space, thanks to the vertical construction form. Further advantages: the high metering accuracy – even at low speeds, the high suction capacity (self-priming) and the low pulsation and continuous pump output, regardless of the pressure and viscosity.

The KB20TL, constructed in block form (not shown), is available as a hygienic pump as well as the KL30TL with bearing bracket (see page 8).

The configuration and length of the pump can be customized according to your wishes.



view from the side,
vertical hanging

KL50T series,
steel version



outlet connection view,
vertical hanging

KL50T series,
stainless steel version

Max. flow rate (m³/h):

0	100	200	300	400	500	600
						525

Max. differential pressure (bar):

0	10	20	30	40	50
		12			

Application-oriented:

Training courses and training

Take advantage of our expertise and benefit from our knowledge at our training courses. Our application-oriented events include professional advice as well as opportunity to exchange experience and to carry out workshops. Whether cross-industry seminars or product-related training, on-site or in our rooms: we want to mediate knowledge here, supplemented, and/or deepen it.

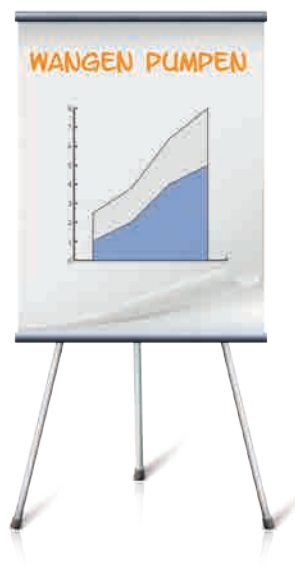

Pointing the way:

Expert Advice

The choice of product, applications or even installation: Our expert team is available with help and advice, it is goal-oriented and will be pleased to familiarize you with its many years of experience, in order to ensure that optimum solutions are provided for the continuous trouble-free operation of our pumps.

We shall be pleased to advise you when seeking solutions for new conveying or pumping tasks, have to work with difficult media, or in particular with special challenges posed by your pump. Qualified, specific and solution oriented.

Contact us if you wish to open up a dialogue - we shall be pleased to support you with the entire range of our consultancy services.



Competent and reliable:

Service

Regular inspections and maintenance by our competent service personnel increases the operational safety and the reliability of a pump and thus reduces your operating costs. We repair the pumps that we produce directly on-site with the customer or in our factory.



Only from WANGEN PUMPEN:

Original Spare Parts

With original pump parts from WANGEN PUMPEN, we guarantee a full and fast recovery in the performance of our pumps. You will be able to profit from our decades of manufacturing experience, and as a consequence, the quality we offer as a manufacturer. In this way, a long service life of your pump is ensured. We even produce spare parts to our high manufacturing standards and use only the original parts.



Professionally and professional standards:

Commissioning, Maintenance and Repair

We offer professional support in the professional installation of your new pump. Because we see in our customers partners who can rely on us and, of course, on our products. Also, for their maintenance and repair.





Online Newsletter

Subscribe now and be informed!

Go to www.wangen.com

Tested quality

WANGEN PUMPEN Quality management is certified to ISO 9001:2008.



Certified sustainability

The WANGEN PUMPEN environmental management is certified according to ISO 14001:2004.



Your contact:

Pumpenfabrik Wangen GmbH

Simoniusstrasse 17

88239 Wangen im Allgäu

Germany

www.wangen.com

Service Hotline: +49 7522 997-997

Spare parts: +49 7522 997-896

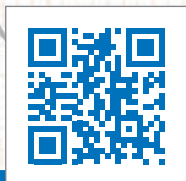

[Link to Homepage](http://www.wangen.com)